

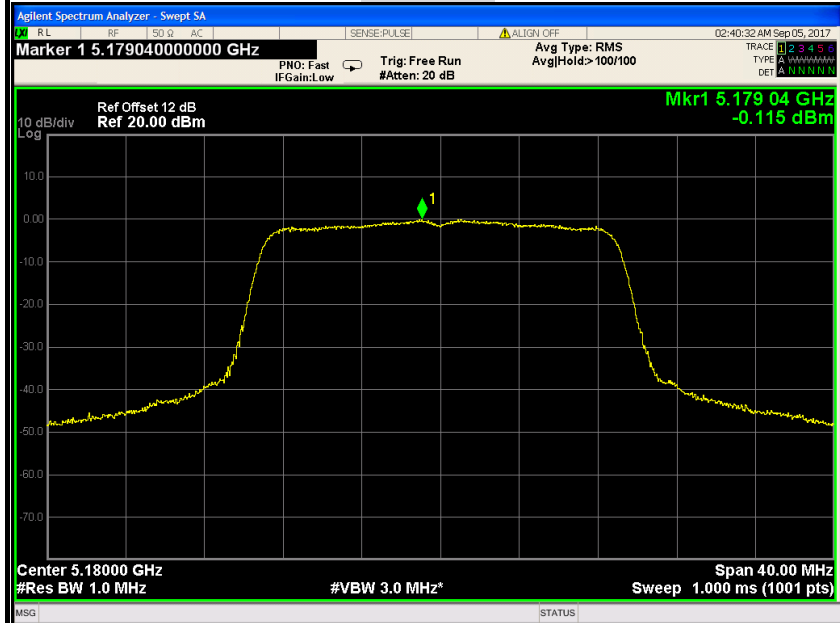

IEEE 802.11n HT 20 MHz mode / 5180 ~ 5240MHz

PPSD (CH Low)

Antenna 0



PPSD (CH Mid)

Antenna 0

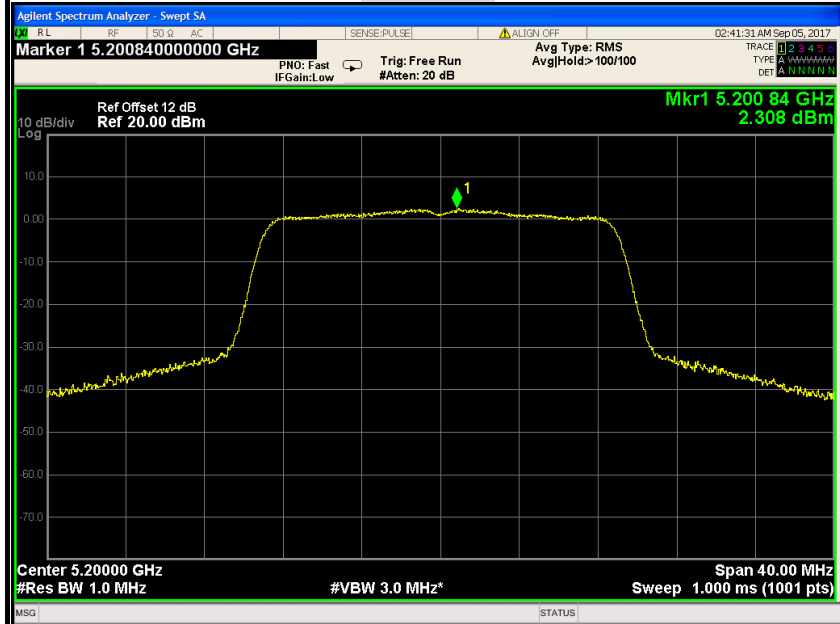

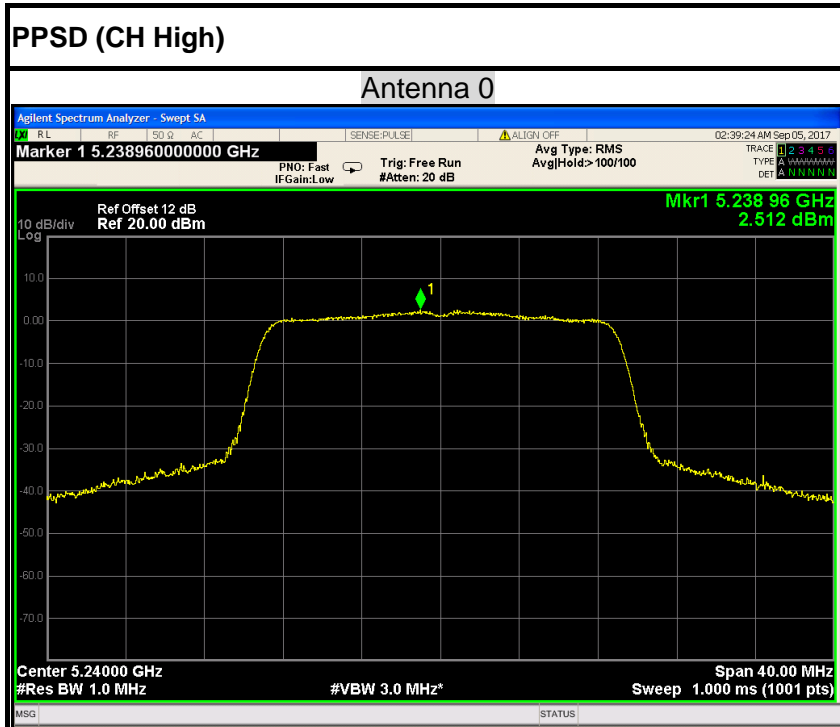

IEEE 802.11n HT 20 MHz mode / 5745 ~ 5825MHz

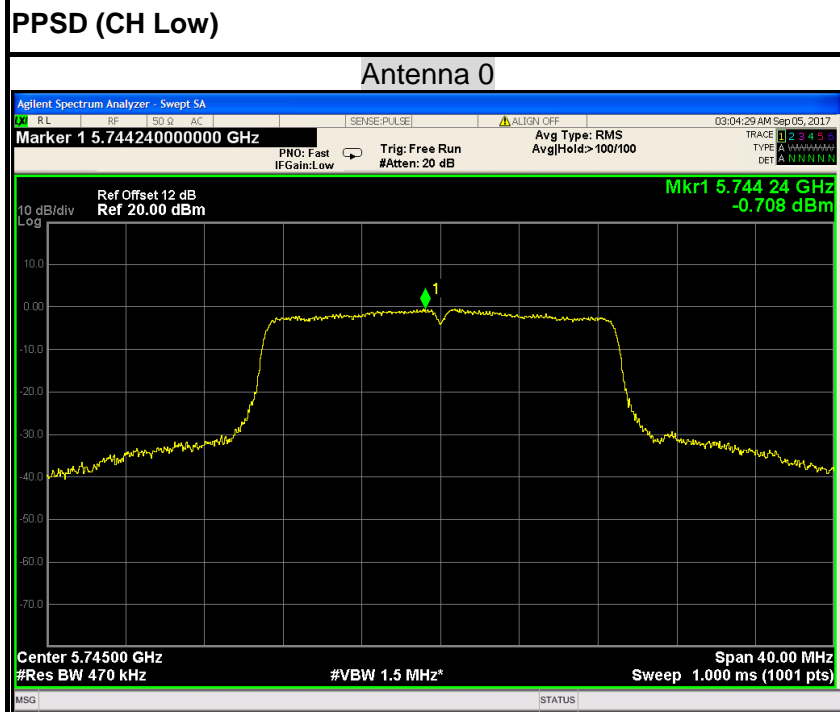

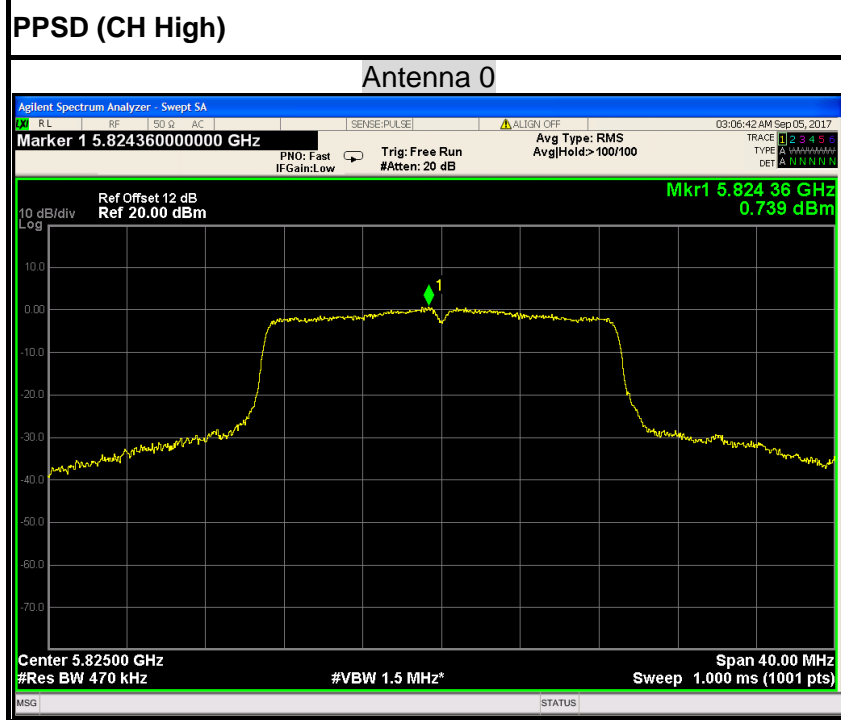
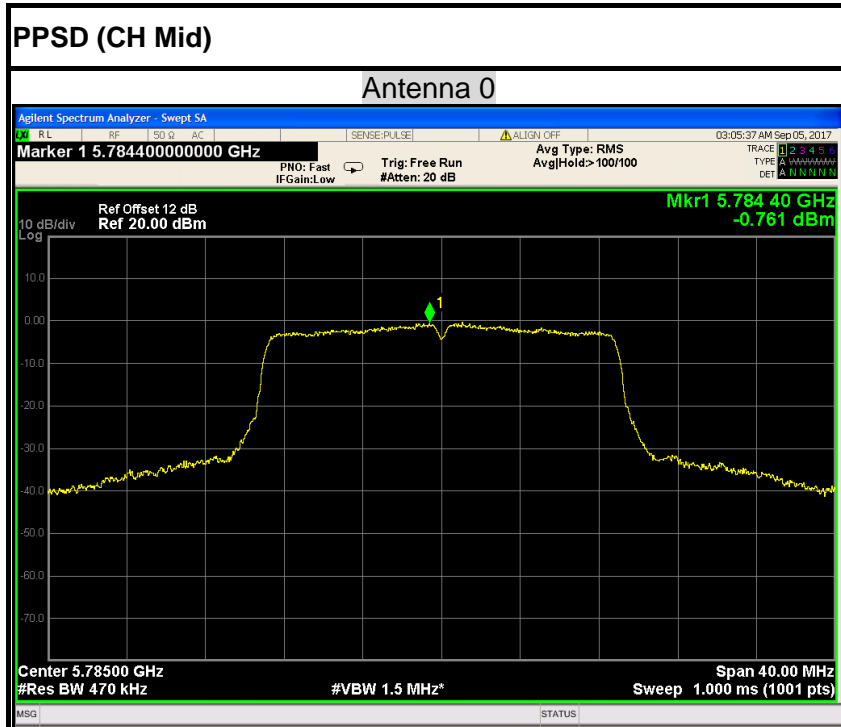



IEEE 802.11n HT 20 MHz mode / 5180 ~ 5240MHz

PPSD (CH Low)

Antenna 1

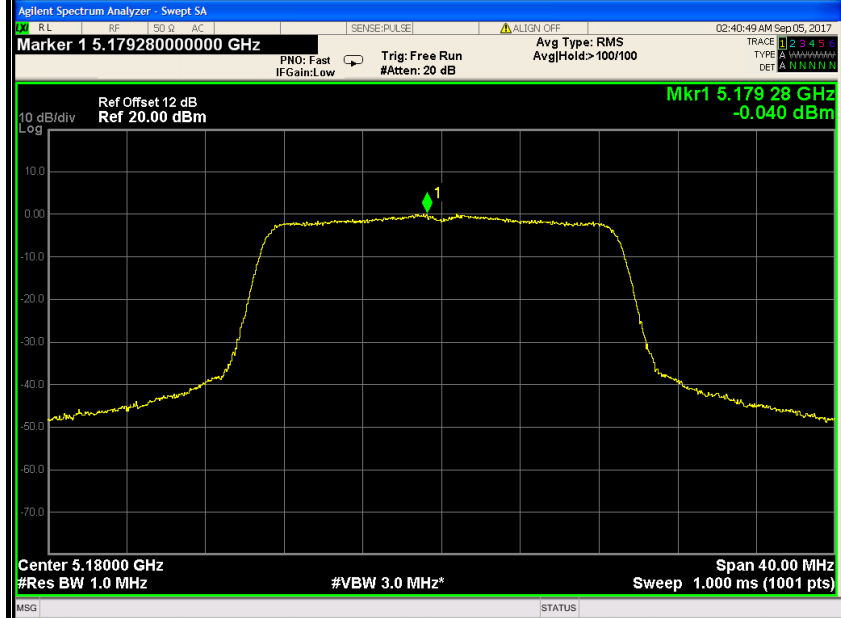

PPSD (CH Mid)

Antenna 1

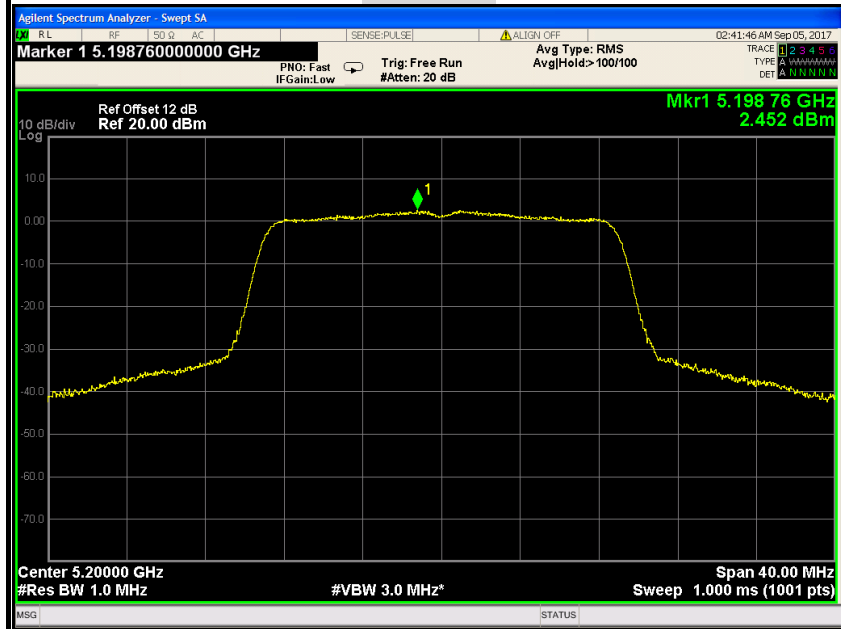

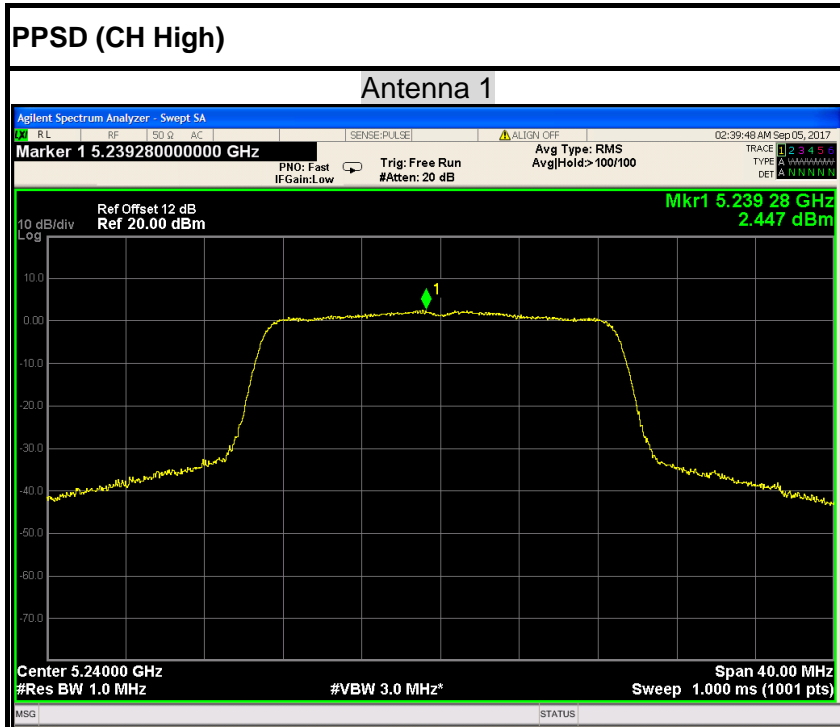

IEEE 802.11n HT 20 MHz mode / 5745 ~ 5825MHz

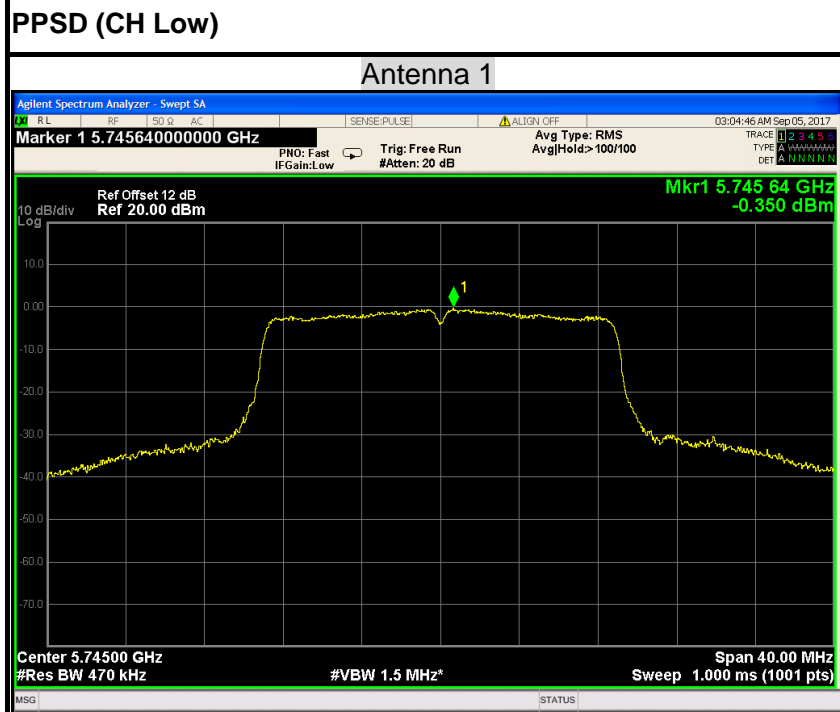

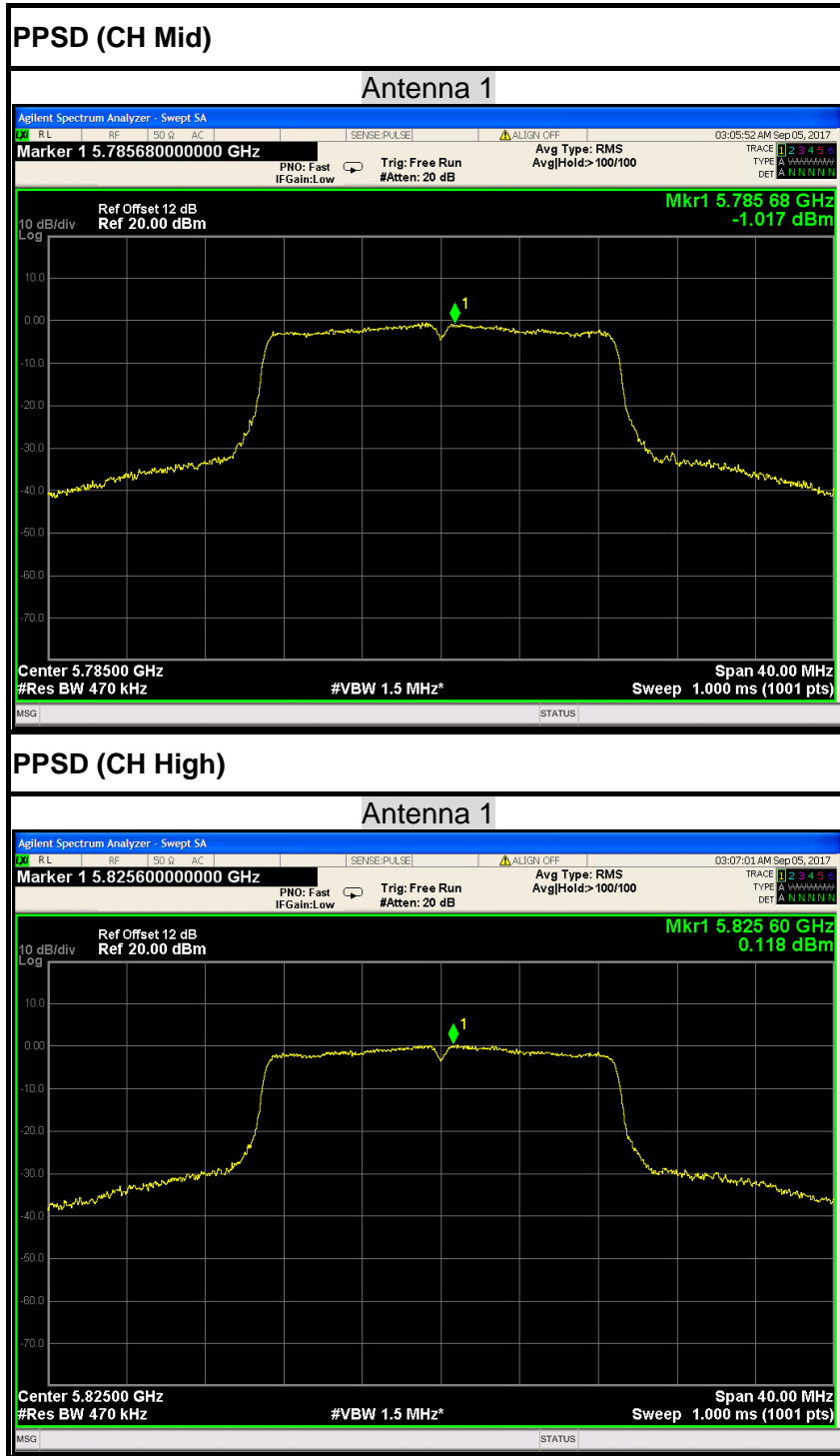

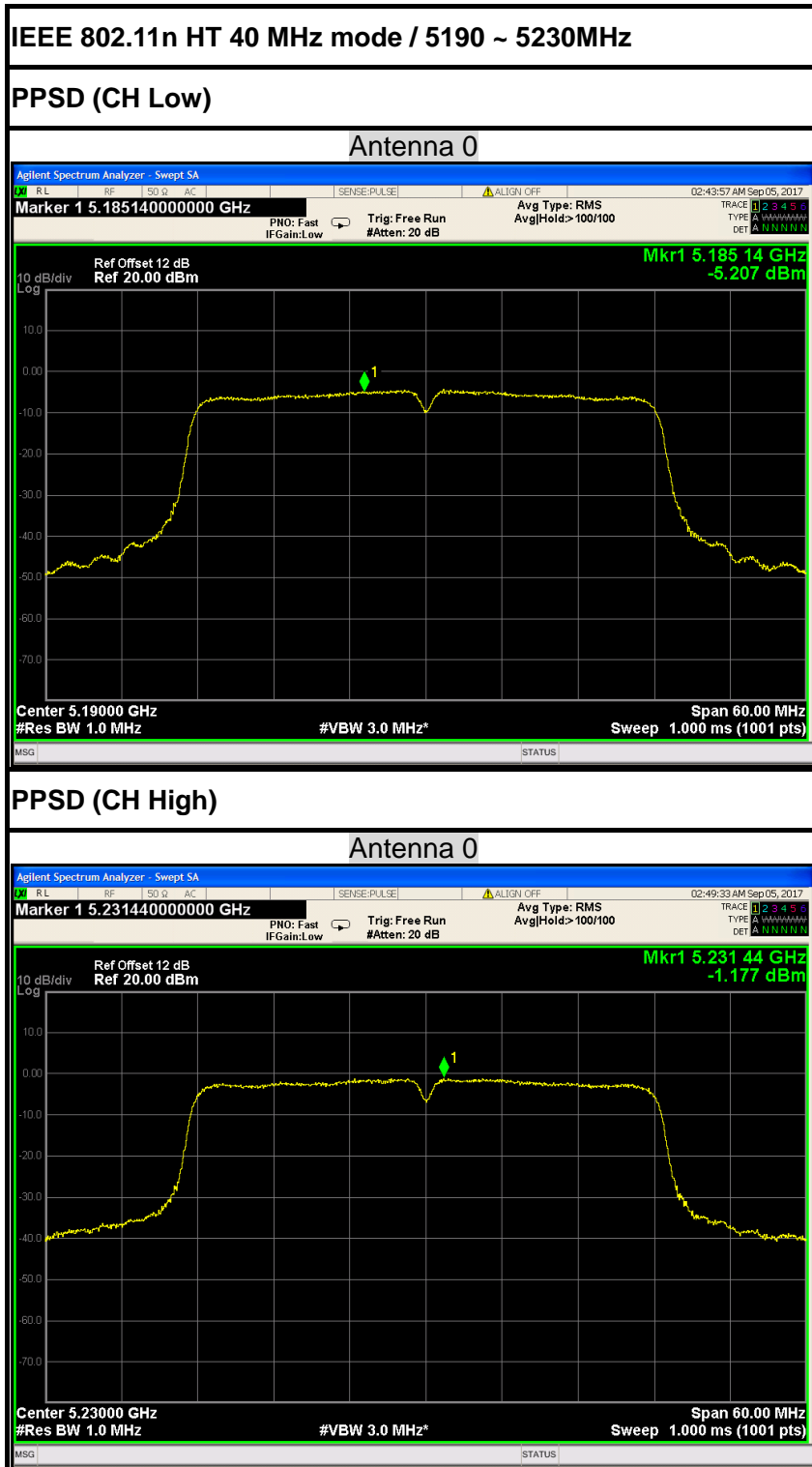

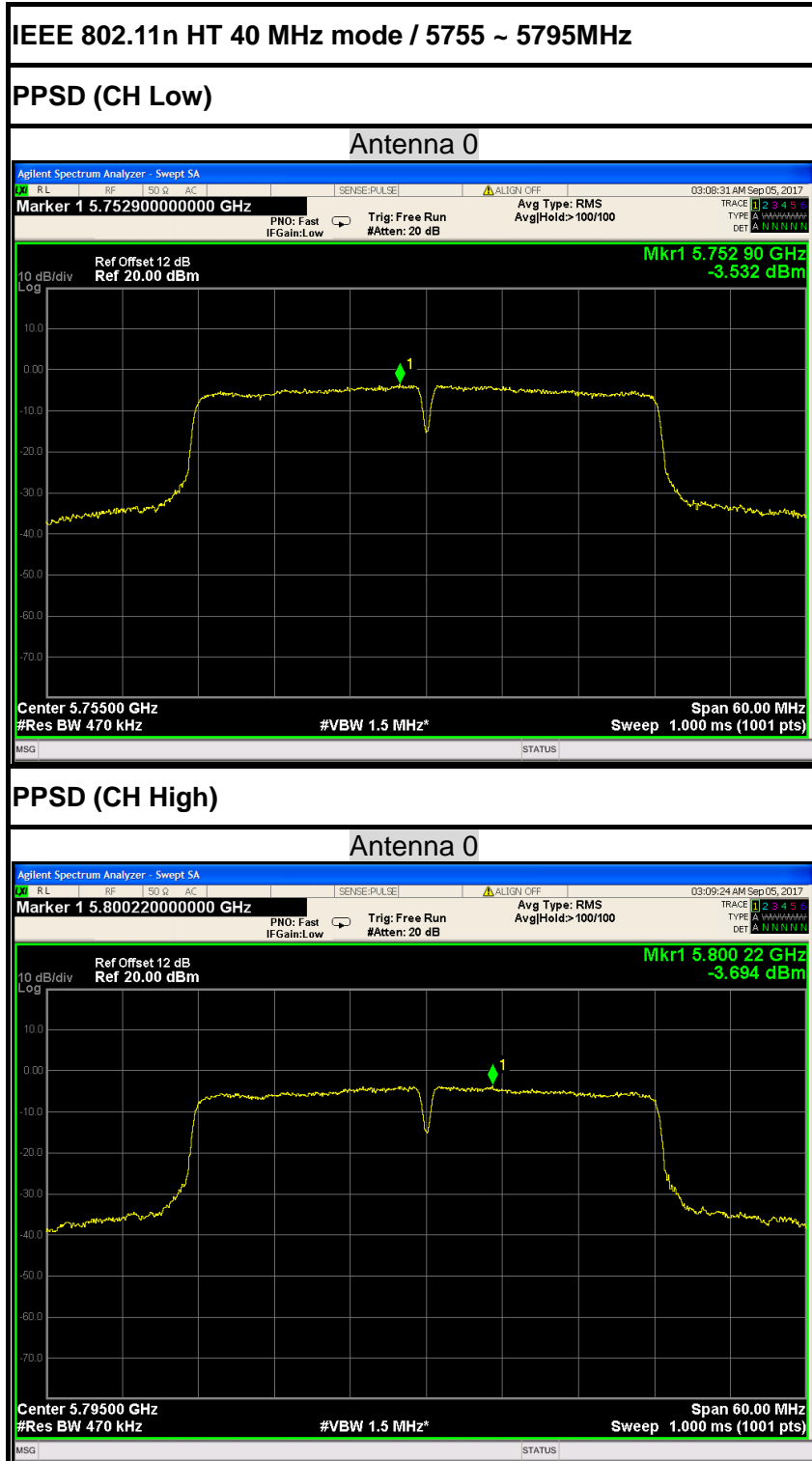



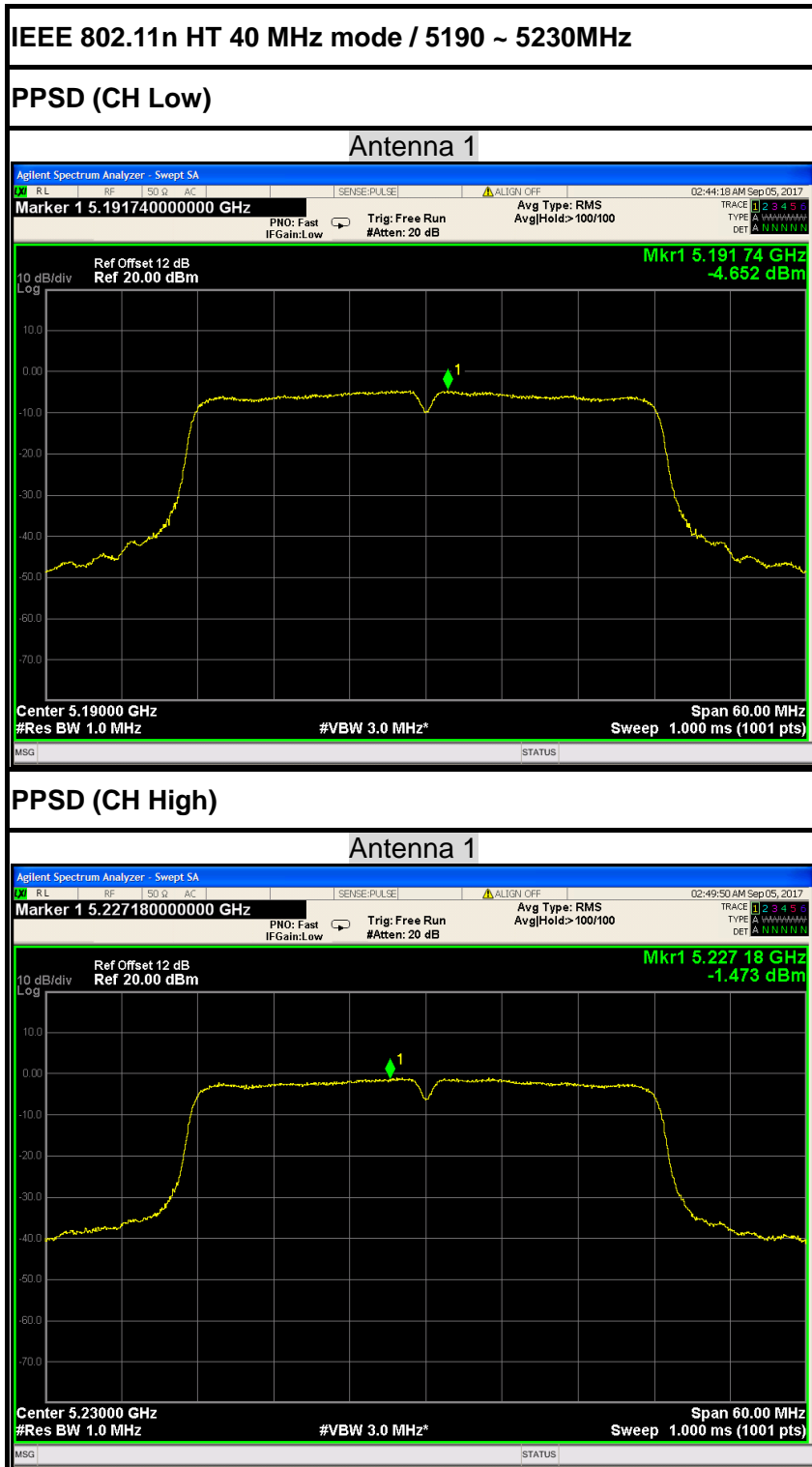

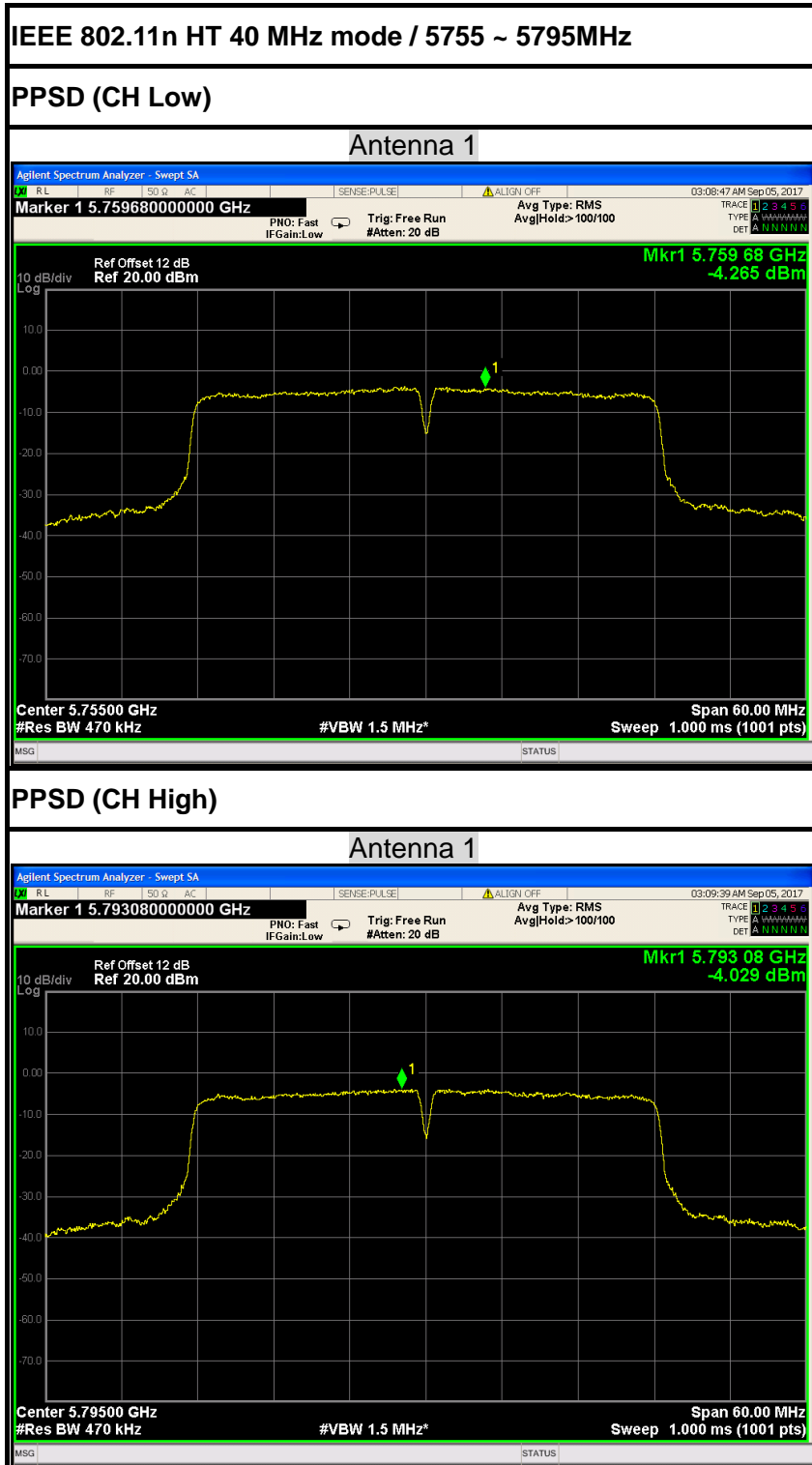

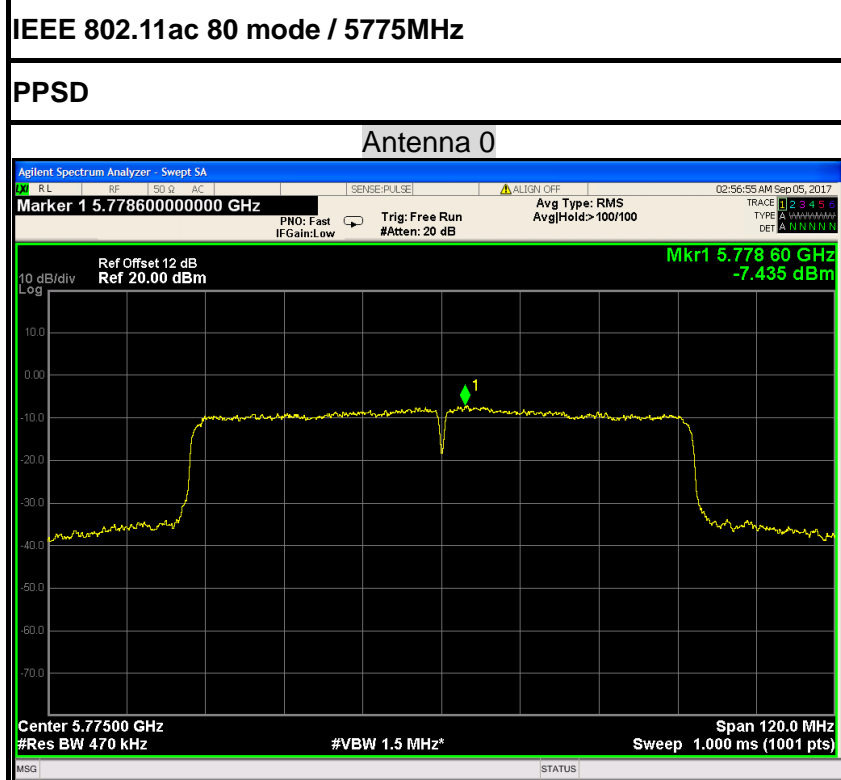
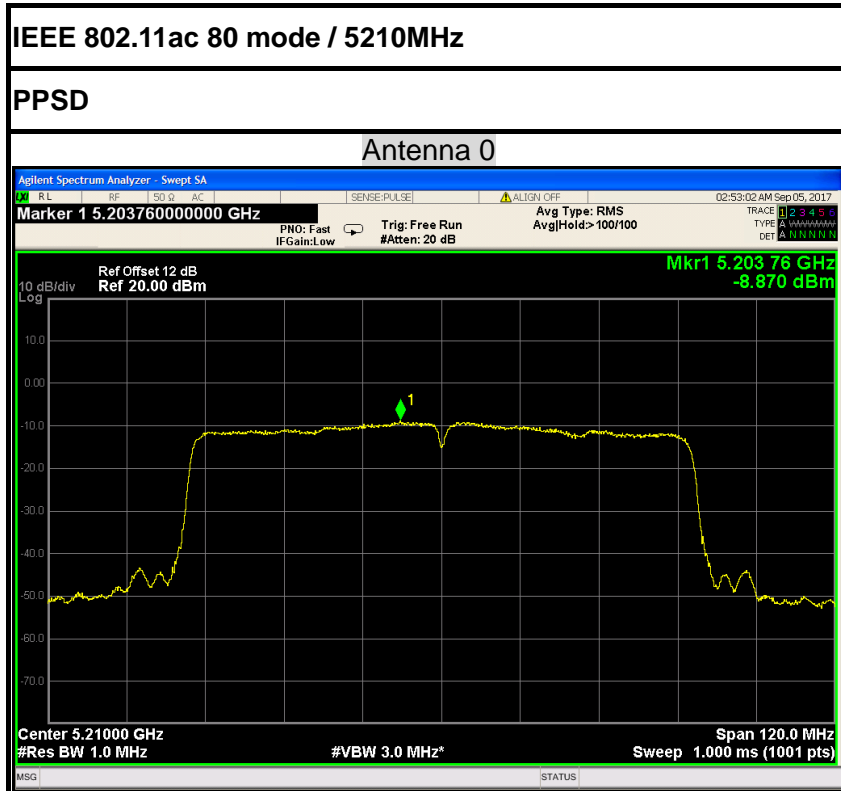

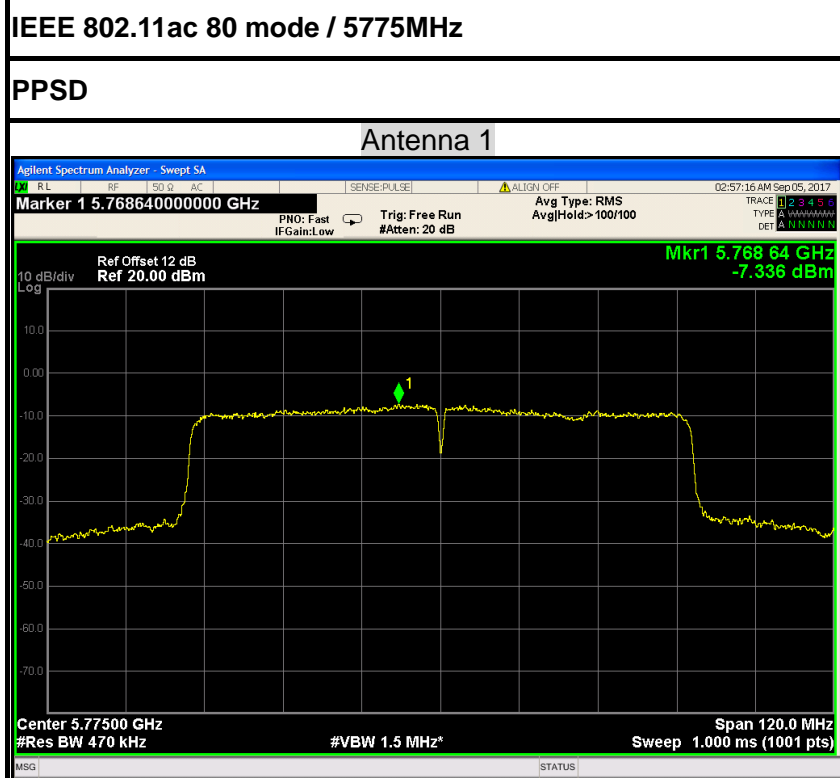
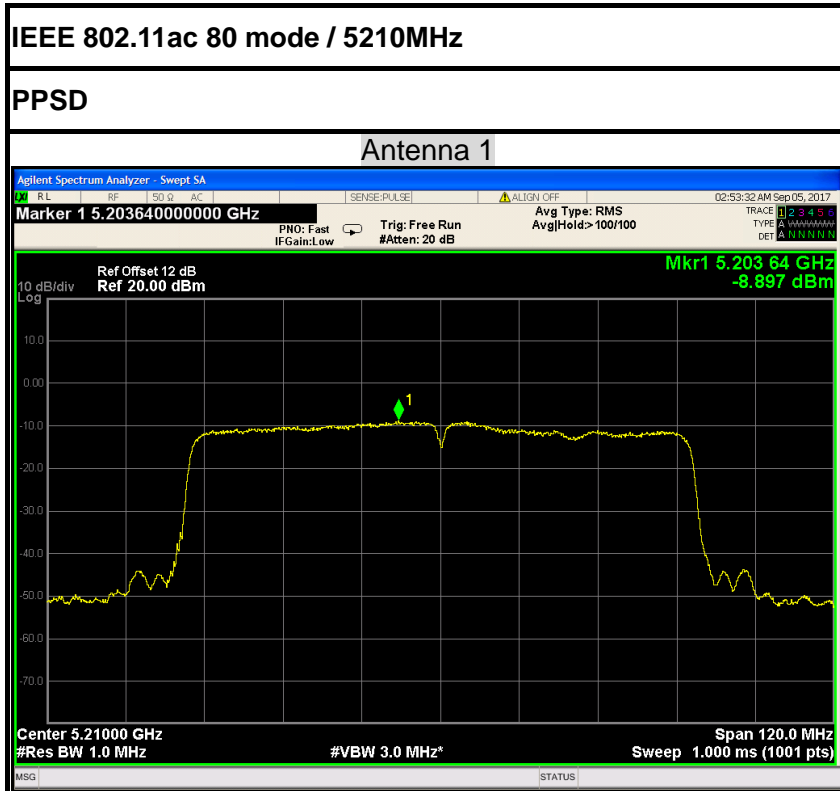



## 6.7 RADIATED UNDESIRABLE EMISSION

### 6.7.1 LIMIT

1. According to §15.209(a), except as provided elsewhere in this Subpart, the emissions from an intentional radiator shall not exceed the field strength levels specified in the following table:

Frequency (MHz)	Field Strength ( $\mu\text{V}/\text{m}$ )	Measurement Distance (m)
30-88	100*	3
88-216	150*	3
216-960	200*	3
Above 960	500	3

**Remark:** Except as provided in paragraph (g), fundamental emissions from intentional radiators operating under this Section shall not be located in the frequency bands 54-72 MHz, 76-88 MHz, 174-216 MHz or 470-806 MHz. However, operation within these frequency bands is permitted under other sections of this Part, e.g., Sections 15.231 and 15.241.

2. In the emission table above, the tighter limit applies at the band edges.

Frequency (MHz)	Field Strength ( $\mu\text{V}/\text{m}$ at 3-meter)	Field Strength ( $\text{dB}\mu\text{V}/\text{m}$ at 3-meter)
30-88	100	40
88-216	150	43.5
216-960	200	46
Above 960	500	54



### 6.7.2 TEST INSTRUMENTS

Radiated Emission Test Site 966 (2)					
Name of Equipment	Manufacturer	Model Number	Serial Number	Last Calibration	Due Calibration
PSA Series Spectrum Analyzer	Agilent	N9010A	MY52221469	02/21/2017	02/20/2018
EMI TEST RECEIVER	ROHDE&SCHWARZ	ESCI	100783	02/21/2017	02/20/2018
Amplifier	EMEC	EM330	060661	03/18/2017	03/17/2018
High Noise Amplifier	Agilent	8449B	3008A01838	02/21/2017	02/20/2018
Loop Antenna	COM-POWER	AL-130	121044	09/25/2017	09/24/2018
Bilog Antenna	SCHAFFNER	CBL6143	5082	02/21/2017	02/20/2018
Horn Antenna	SCHWARZBECK	BBHA9120	D286	02/27/2017	02/27/2018
Board-Band Horn Antenna	Schwarzbeck	BBHA 9170	9170-497	02/27/2017	02/27/2018
Turn Table	N/A	N/A	N/A	N.C.R	N.C.R
Antenna Tower	SUNOL	TLT2	N/A	N.C.R	N.C.R
Controller	Sunol Sciences	SC104V	022310-1	N.C.R	N.C.R
Controller	CT	N/A	N/A	N.C.R	N.C.R
Temp. / Humidity Meter	Anymetre	JR913	N/A	02/21/2017	02/20/2018
Test S/W	FARAD	LZ-RF / CCS-SZ-3A2			

### 6.7.3 TEST CONFIGURATION

#### Below 30MHz

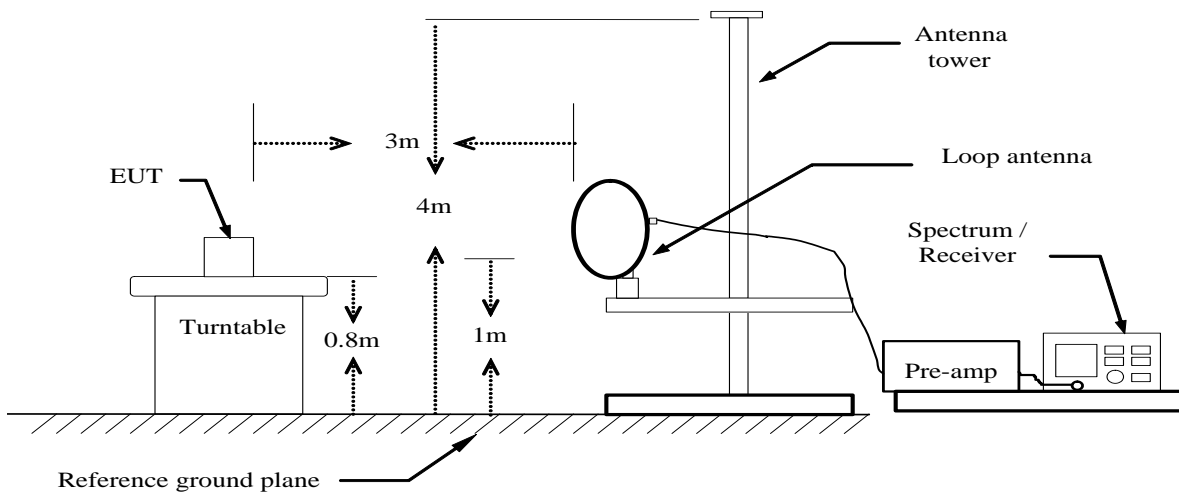



**Below 1 GHz**

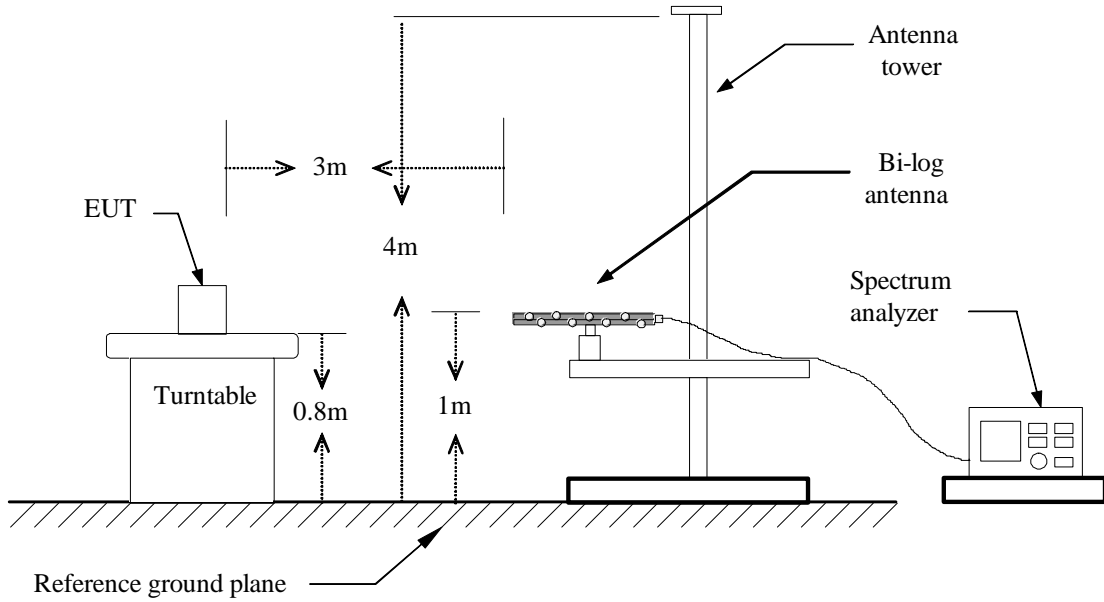

**Above 1 GHz**

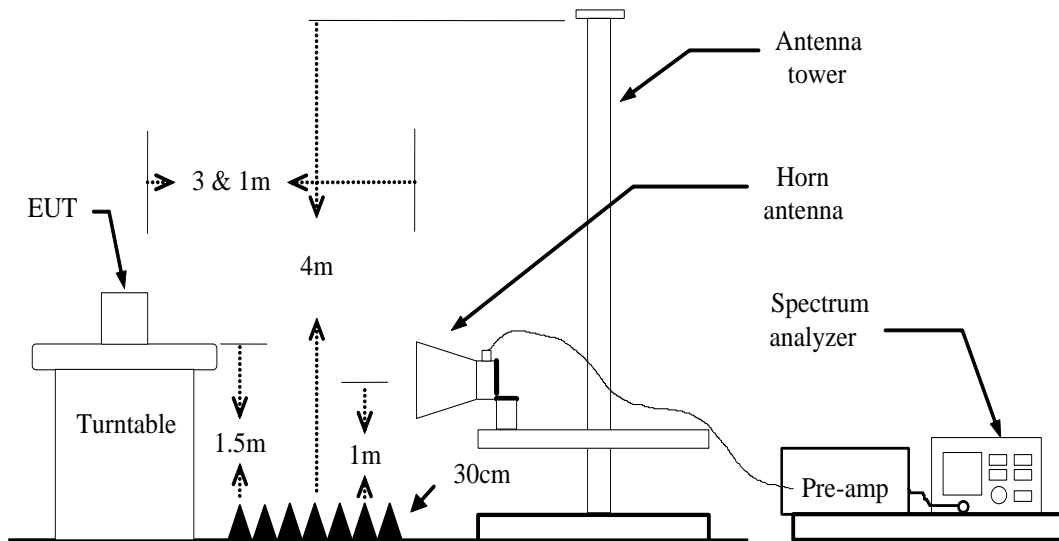

For the actual test configuration, please refer to the related item – Photographs of the TEST CONFIGURATION.



### 6.7.4 MEASURING SETTING

The following table is the setting of spectrum analyzer and receiver.

Spectrum Parameter	Setting
Attenuation	Auto
Start Frequency	1000 MHz
Stop Frequency	10th carrier harmonic
RB / VB (Emission in restricted band)	1MHz / 1MHz for Peak, 1 MHz / 1/T for Average
RB / VB (Emission in non-restricted band)	1MHz / 1MHz for Peak, 1 MHz / 1/T for Average

Receiver Parameter	Setting
Attenuation	Auto
Start ~ Stop Frequency	9kHz~150kHz / RB 200Hz for QP/AVG
Start ~ Stop Frequency	150kHz~30MHz / RB 9kHz for QP/AVG
Start ~ Stop Frequency	30MHz~1000MHz / RB 100kHz for QP

### 6.7.5 TEST PROCEDURE

#### 1) Sequence of testing 9 kHz to 30 MHz

##### Setup:

- The equipment was set up to simulate a typical usage like described in the user manual or described by manufacturer.
- If the EUT is a tabletop system, a rotatable table with 0.8 m height is used.
- If the EUT is a floor standing device, it is placed on the ground.
- Auxiliary equipment and cables were positioned to simulate normal operation conditions.
- The AC power port of the EUT (if available) is connected to a power outlet below the turntable.
- The measurement distance is 3 meter.
- The EUT was set into operation.

##### Pre measurement:

- The turntable rotates from 0° to 315° using 45° steps.
- The antenna height is 0.8 meter.





--- At each turntable position the analyzer sweeps with peak detection to find the maximum of all emissions

**Final measurement:**

--- Identified emissions during the pre measurement the software maximizes by rotating the turntable position (0° to 360°) and by rotating the elevation axes (0° to 360°).

--- The final measurement will be done in the position (turntable and elevation) causing the highest emissions with QPK detector.

--- The final levels, frequency, measuring time, bandwidth, turntable position, correction factor, margin to the limit and limit will be recorded. Also a plot with the graph of the pre measurement and the limit will be stored.

**2) Sequence of testing 30 MHz to 1 GHz**

**Setup:**

--- The equipment was set up to simulate a typical usage like described in the user manual or described by manufacturer.

--- If the EUT is a tabletop system, a table with 0.8 m height is used, which is placed on the ground plane.

--- If the EUT is a floor standing device, it is placed on the ground plane with insulation between both.

--- Auxiliary equipment and cables were positioned to simulate normal operation conditions

--- The AC power port of the EUT (if available) is connected to a power outlet below the turntable.

--- The measurement distance is 3 meter.

--- The EUT was set into operation.

**Pre measurement:**

--- The turntable rotates from 0° to 315° using 45° steps.

--- The antenna is polarized vertical and horizontal.

--- The antenna height changes from 1 to 3 meter.

--- At each turntable position, antenna polarization and height the analyzer sweeps three times in peak to find the maximum of all emissions.



**Final measurement:**

- The final measurement will be performed with minimum the six highest peaks.
- According to the maximum antenna and turntable positions of premeasurement the software maximize the peaks by changing turntable position ( $\pm 45^\circ$ ) and antenna movement between 1 and 4 meter.
- The final measurement will be done with QP detector with an EMI receiver.
- The final levels, frequency, measuring time, bandwidth, antenna height, antenna polarization, turntable angle, correction factor, margin to the limit and limit will be recorded. Also a plot with the graph of the premeasurement with marked maximum final measurements and the limit will be stored.

**3) Sequence of testing 1 GHz to 18 GHz**

**Setup:**

- The equipment was set up to simulate a typical usage like described in the user manual or described by manufacturer.
- If the EUT is a tabletop system, a rotatable table with 1.5 m height is used.
- If the EUT is a floor standing device, it is placed on the ground plane with insulation between both.
- Auxiliary equipment and cables were positioned to simulate normal operation conditions
- The AC power port of the EUT (if available) is connected to a power outlet below the turntable.
- The measurement distance is 3 meter.
- The EUT was set into operation.

**Pre measurement:**

- The turntable rotates from  $0^\circ$  to  $315^\circ$  using  $45^\circ$  steps.
- The antenna is polarized vertical and horizontal.
- The antenna height scan range is 1 meter to 2.5 meter.
- At each turntable position and antenna polarization the analyzer sweeps with peak detection to find the maximum of all emissions.



**Final measurement:**

--- The final measurement will be performed with minimum the six highest peaks.

--- According to the maximum antenna and turntable positions of premeasurement the software maximize the peaks by changing turntable position ( $\pm 45^\circ$ ) and antenna movement between 1 and 4 meter. This procedure is repeated for both antenna polarizations.

--- The final measurement will be done in the position (turntable, EUT-table and antenna polarization) causing the highest emissions with Peak and Average detector.

--- The final levels, frequency, measuring time, bandwidth, turntable position, EUT-table position, antenna polarization, correction factor, margin to the limit and limit will be recorded. Also a plot with the graph of the pre measurement with marked maximum final measurements and the limit will be stored.

**4) Sequence of testing above 18 GHz**

**Setup:**

--- The equipment was set up to simulate a typical usage like described in the user manual or described by manufacturer.

--- If the EUT is a tabletop system, a rotatable table with 1.5 m height is used.

--- If the EUT is a floor standing device, it is placed on the ground plane with insulation between both.

--- Auxiliary equipment and cables were positioned to simulate normal operation conditions

--- The AC power port of the EUT (if available) is connected to a power outlet below the turntable.

--- The measurement distance is 1 meter.

--- The EUT was set into operation.

**Pre measurement:**

--- The antenna is moved spherical over the EUT in different polarisations of the antenna.

**Final measurement:**

--- The final measurement will be performed at the position and antenna orientation for all detected emissions that were found during the premeasurements with Peak and Average detector.

--- The final levels, frequency, measuring time, bandwidth, correction factor, margin to the limit and limit will be recorded. Also a plot with the graph of the premeasurement and the limit will be stored.



6.7.6 DATA SAPLE

Below 1GHz

Frequency (MHz)	Reading (dBuV)	Correct Factor (dB/m)	Result (dBuV/m)	Limit (dBuV/m)	Margin (dB)	Antenna Pole (V/H)	Remark
XXX.XXXX	36.37	-12.20	24.17	40.00	-15.83	V	QP

Frequency (MHz) = Emission frequency in MHz  
 Reading (dBuV) = Uncorrected Analyzer / Receiver reading  
 Correct Factor (dB/m) = Antenna factor + Cable loss – Amplifier gain  
 Result (dBuV/m) = Reading (dBuV) + Corr. Factor (dB/m)  
 Limit (dBuV/m) = Limit stated in standard  
 Margin (dB) = Result (dBuV/m) – Limit (dBuV/m)  
 Q.P. = Quasi-peak Reading

Above 1GHz

Frequency (MHz)	Reading (dBuV)	Correction Factor (dB/m)	Result (dBuV/m)	Limit (dBuV/m)	Margin (dB)	Antenna Pole (V/H)	Remark
XXXX.XXXX	62.09	-11.42	50.67	74.00	-23.33	V	Peak
XXXX.XXXX	49.78	-11.42	38.36	54.00	-15.64	V	AVG

Frequency (MHz) = Emission frequency in MHz  
 Reading (dBuV) = Uncorrected Analyzer / Receiver reading  
 Correction Factor (dB/m) = Antenna factor + Cable loss – Amplifier gain  
 Result (dBuV/m) = Reading (dBuV) + Corr. Factor (dB/m)  
 Limit (dBuV/m) = Limit stated in standard  
 Margin (dB) = Result (dBuV/m) – Limit (dBuV/m)  
 Peak = Peak Reading  
 AVG = Average Reading

**Calculation Formula**

Margin (dB) = Result (dBuV/m) – Limits (dBuV/m)  
 Result (dBuV/m) = Reading (dBuV) + Correction Factor



**6.7.7 TEST RESULTS**

**Below 1 GHz**

**Test Mode:** TX / IEEE 802.11a / 5180MHz /(CH Low)

**Tested by:** Fade Zhong

**Ambient temperature:** 24°C **Relative humidity:** 52% RH

**Date:** August 26, 2017

Frequency (MHz)	Reading (dBuV)	Correction Factor (dB/m)	Result (dBuV/m)	Limit (dBuV/m)	Margin (dB)	Antenna Pole (V/H)	Remark
38.7300	52.07	-19.94	32.13	40.00	-7.87	V	QP
94.0200	45.28	-15.46	29.82	43.50	-13.68	V	QP
250.1900	43.60	-9.09	34.51	46.00	-11.49	V	QP
500.4500	44.13	-6.10	38.03	46.00	-7.97	V	QP
749.7400	29.45	-3.11	26.34	46.00	-19.66	V	QP
879.7200	31.10	-2.18	28.92	46.00	-17.08	V	QP
94.0200	46.79	-15.46	31.33	43.50	-12.17	H	QP
138.6400	43.69	-12.14	31.55	43.50	-11.95	H	QP
199.7500	41.91	-10.23	31.68	43.50	-11.82	H	QP
250.1900	50.37	-9.09	41.28	46.00	-4.72	H	QP
306.4500	36.51	-8.19	28.32	46.00	-17.68	H	QP
500.4500	44.05	-6.10	37.95	46.00	-8.05	H	QP

Pre-scan all mode and recorded the worst case results in this report (802.11a (Low Mid)).

**Remark:**

1. No emission found between lowest internal used/generated frequency to 30MHz (9kHz~30MHz)
2. Radiated emissions measured in frequency range from 30 MHz to 1000MHz were made with an instrument using peak/quasi-peak detector mode.
3. Quasi-peak test would be performed if the peak result were greater than the quasi-peak limit.
4. Data of measurement within this frequency range shown " --- " in the table above means the reading of emissions are attenuated more than 20dB below the permissible limits or the field strength is too small to be measured.
5. Measurements above show only up to 6 maximum emissions noted, or would be lesser, with " N/A " remark, if no specific emissions from the EUT are recorded (ie: margin>20dB from the applicable limit) and considered that's already beyond the background noise floor.
6. Margin (dB) = Remark result (dBuV/m) – Quasi-peak limit (dBuV/m).



### Vertical

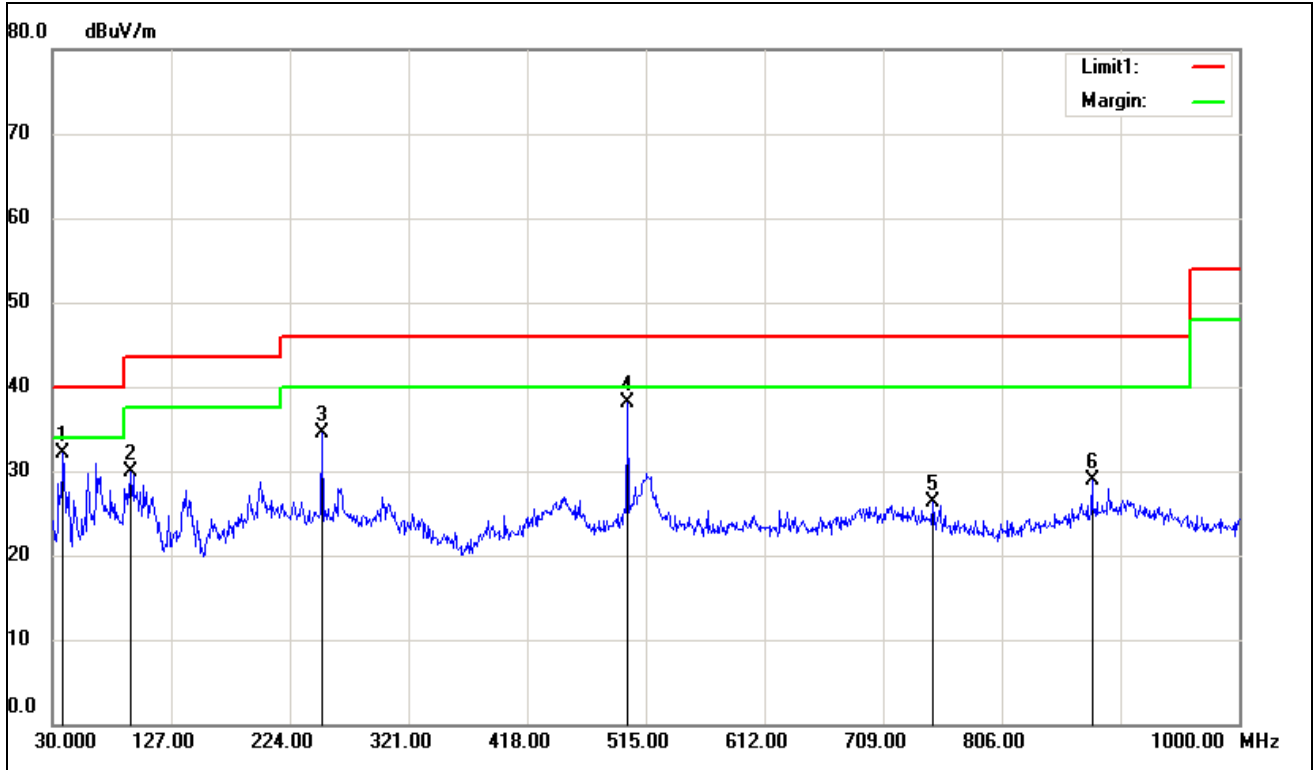

### Horizontal

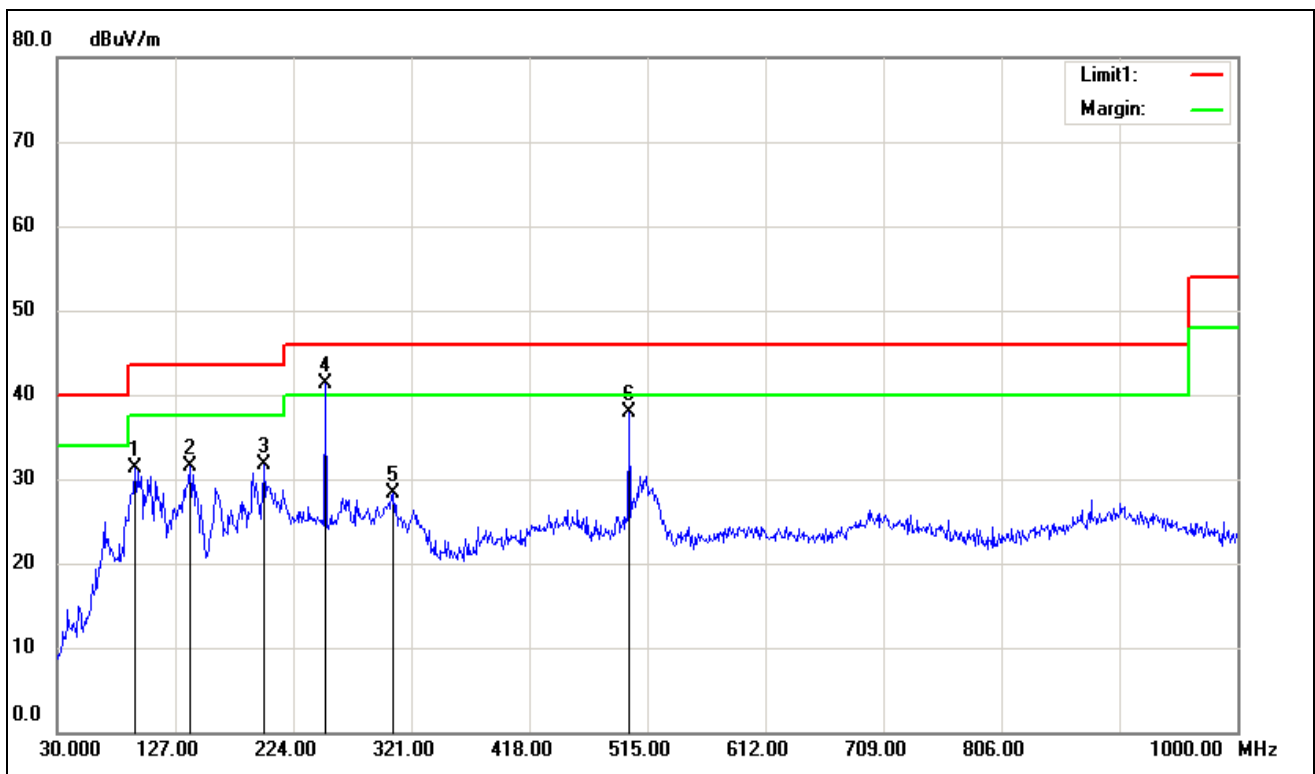



**Above 1-6GHz**

**Test Mode:** TX / IEEE 802.11a / 5180MHz /(CH Low)

**Tested by:** Fade Zhong

**Ambient temperature:** 24°C **Relative humidity:** 52% RH

**Date:** August 24, 2017

Frequency (MHz)	Reading (dBuV)	Correction Factor (dB/m)	Result (dBuV/m)	Limit (dBuV/m)	Margin (dB)	Antenna Pole (V/H)	Remark
1550.000	54.40	-6.79	47.61	68.23	-20.62	V	peak
1925.000	47.85	-5.48	42.37	68.23	-25.86	V	peak
2240.000	47.10	-3.68	43.42	68.23	-24.81	V	peak
2660.000	46.53	-1.97	44.56	68.23	-23.67	V	peak
3200.000	45.62	-1.02	44.60	68.23	-23.63	V	peak
4000.000	44.14	1.59	45.73	68.23	-22.50	V	peak
1820.000	52.45	-6.14	46.31	68.23	-21.92	H	Peak
2015.000	50.48	-4.92	45.56	68.23	-22.67	H	Peak
2500.000	53.31	-2.26	51.05	68.23	-17.18	H	Peak
2800.000	49.40	-1.72	47.68	68.23	-20.55	H	peak
3455.000	48.13	-0.60	47.53	68.23	-20.70	H	peak
3600.000	49.99	-0.10	49.89	68.23	-18.34	H	peak

**Remark:**

1. Measuring frequencies from 1 GHz to the 10th harmonic of highest fundamental frequency.
2. Radiated emissions measured in frequency above 1000MHz were made with an instrument using peak/average detector mode.
3. Average test would be performed if the peak result were greater than the average limit.
4. Data of measurement within this frequency range shown " --- " in the table above means the reading of emissions are attenuated more than 20dB below the permissible limits or the field strength is too small to be measured.
5. Measurements above show only up to 6 maximum emissions noted, or would be lesser, with " N/A " remark, if no specific emissions from the EUT are recorded (ie: margin>20dB from the applicable limit) and considered that's already beyond the background noise floor.
6. Margin (dB) = Remark result (dBuV/m) – Average limit (dBuV/m).



**Above 6GHz**

**Antenna 0**

**Test Mode:** TX / IEEE 802.11a / 5180MHz /(CH Low)

**Tested by:** Fade Zhong

**Ambient temperature:** 24°C **Relative humidity:** 52% RH

**Date:** August 24, 2017

Frequency (MHz)	Reading (dBuV)	Correction Factor (dB/m)	Result (dBuV/m)	Limit (dBuV/m)	Margin (dB)	Antenna Pole (V/H)	Remark
7548.000	31.55	8.77	40.32	74.00	-33.68	V	peak
8412.000	31.66	9.42	41.08	74.00	-32.92	V	peak
11148.000	31.55	15.01	46.56	74.00	-27.44	V	peak
11592.000	30.63	14.82	45.45	74.00	-28.55	V	peak
13284.000	29.53	18.70	48.23	74.00	-25.77	V	peak
14376.000	31.30	20.80	52.10	74.00	-21.90	V	peak
8028.000	32.02	9.63	41.65	74.00	-32.35	H	Peak
9816.000	30.85	11.45	42.30	74.00	-31.70	H	Peak
11148.000	31.48	15.01	46.49	74.00	-27.51	H	Peak
12624.000	29.62	16.71	46.33	74.00	-27.67	H	peak
14028.000	30.68	20.60	51.28	74.00	-22.72	H	peak
14412.000	31.38	20.82	52.20	74.00	-21.80	H	peak

**Remark:**

1. Measuring frequencies from 1 GHz to the 10th harmonic of highest fundamental frequency.
2. Radiated emissions measured in frequency above 1000MHz were made with an instrument using peak/average detector mode.
3. Average test would be performed if the peak result were greater than the average limit.
4. Data of measurement within this frequency range shown " --- " in the table above means the reading of emissions are attenuated more than 20dB below the permissible limits or the field strength is too small to be measured.
5. Measurements above show only up to 6 maximum emissions noted, or would be lesser, with " N/A " remark, if no specific emissions from the EUT are recorded (ie: margin>20dB from the applicable limit) and considered that's already beyond the background noise floor.
6. Margin (dB) = Remark result (dBuV/m) – Average limit (dBuV/m).





Test Mode: TX / IEEE 802.11a / 5200MHz /(CH Mid)

Tested by: Fade Zhong

Ambient temperature: 24°C Relative humidity: 52% RH

Date: August 24, 2017

Frequency (MHz)	Reading (dBuV)	Correction Factor (dB/m)	Result (dBuV/m)	Limit (dBuV/m)	Margin (dB)	Antenna Pole (V/H)	Remark
8448.000	31.94	9.40	41.34	74.00	-32.66	V	peak
10032.000	30.91	12.08	42.99	74.00	-31.01	V	peak
11148.000	31.24	15.01	46.25	74.00	-27.75	V	peak
12624.000	29.99	16.71	46.70	74.00	-27.30	V	peak
13272.000	28.75	18.67	47.42	74.00	-26.58	V	peak
14364.000	31.36	20.79	52.15	74.00	-21.85	V	peak
8100.000	32.16	9.60	41.76	74.00	-32.24	H	Peak
9348.000	31.64	10.10	41.74	74.00	-32.26	H	Peak
11160.000	31.82	15.01	46.83	74.00	-27.17	H	Peak
12552.000	30.40	16.47	46.87	74.00	-27.13	H	peak
13332.000	29.75	18.82	48.57	74.00	-25.43	H	peak
14328.000	31.89	20.77	52.66	74.00	-21.34	H	peak

**Remark:**

1. Measuring frequencies from 1 GHz to the 10th harmonic of highest fundamental frequency.
2. Radiated emissions measured in frequency above 1000MHz were made with an instrument using peak/average detector mode.
3. Average test would be performed if the peak result were greater than the average limit.
4. Data of measurement within this frequency range shown " --- " in the table above means the reading of emissions are attenuated more than 20dB below the permissible limits or the field strength is too small to be measured.
5. Measurements above show only up to 6 maximum emissions noted, or would be lesser, with " N/A " remark, if no specific emissions from the EUT are recorded (ie: margin>20dB from the applicable limit) and considered that's already beyond the background noise floor.
6. Margin (dB) = Remark result (dBuV/m) – Average limit (dBuV/m).



Test Mode: TX / IEEE 802.11a / 5240MHz /(CH High)

Tested by: Fade Zhong

Ambient temperature: 24°C Relative humidity: 52% RH

Date: August 24, 2017

Frequency (MHz)	Reading (dBuV)	Correction Factor (dB/m)	Result (dBuV/m)	Limit (dBuV/m)	Margin (dB)	Antenna Pole (V/H)	Remark
7752.000	31.58	9.17	40.75	74.00	-33.25	V	peak
9324.000	31.27	10.03	41.30	74.00	-32.70	V	peak
10704.000	30.78	14.16	44.94	74.00	-29.06	V	peak
11148.000	31.51	15.01	46.52	74.00	-27.48	V	peak
12684.000	29.77	16.90	46.67	74.00	-27.33	V	peak
14472.000	31.48	20.85	52.33	74.00	-21.67	V	peak
8004.000	32.09	9.65	41.74	74.00	-32.26	H	Peak
10512.000	30.49	13.57	44.06	74.00	-29.94	H	Peak
11148.000	32.04	15.01	47.05	74.00	-26.95	H	Peak
12696.000	29.71	16.94	46.65	74.00	-27.35	H	peak
13752.000	30.97	19.93	50.90	74.00	-23.10	H	peak
14484.000	31.53	20.86	52.39	74.00	-21.61	H	peak

**Remark:**

1. Measuring frequencies from 1 GHz to the 10th harmonic of highest fundamental frequency.
2. Radiated emissions measured in frequency above 1000MHz were made with an instrument using peak/average detector mode.
3. Average test would be performed if the peak result were greater than the average limit.
4. Data of measurement within this frequency range shown " --- " in the table above means the reading of emissions are attenuated more than 20dB below the permissible limits or the field strength is too small to be measured.
5. Measurements above show only up to 6 maximum emissions noted, or would be lesser, with " N/A " remark, if no specific emissions from the EUT are recorded (ie: margin>20dB from the applicable limit) and considered that's already beyond the background noise floor.
6. Margin (dB) = Remark result (dBuV/m) – Average limit (dBuV/m).



Test Mode: TX / IEEE 802.11a / 5745MHz /(CH Low)

Tested by: Fade Zhong

Ambient temperature: 24°C

Relative humidity: 52% RH

Date: August 24, 2017

Frequency (MHz)	Reading (dBuV)	Correction Factor (dB/m)	Result (dBuV/m)	Limit (dBuV/m)	Margin (dB)	Antenna Pole (V/H)	Remark
8124.000	32.20	9.58	41.78	74.00	-32.22	V	peak
9300.000	30.82	9.96	40.78	74.00	-33.22	V	peak
11148.000	31.71	15.01	46.72	74.00	-27.28	V	peak
11928.000	31.23	14.67	45.90	74.00	-28.10	V	peak
13812.000	31.15	20.09	51.24	74.00	-22.76	V	peak
14784.000	31.05	21.03	52.08	74.00	-21.92	V	peak
7944.000	32.01	9.54	41.55	74.00	-32.45	H	Peak
9672.000	30.54	11.04	41.58	74.00	-32.42	H	Peak
11172.000	31.37	15.00	46.37	74.00	-27.63	H	Peak
12624.000	29.94	16.71	46.65	74.00	-27.35	H	peak
13272.000	29.17	18.67	47.84	74.00	-26.16	H	peak
14364.000	31.53	20.79	52.32	74.00	-21.68	H	peak

**Remark:**

1. Measuring frequencies from 1 GHz to the 10th harmonic of highest fundamental frequency.
2. Radiated emissions measured in frequency above 1000MHz were made with an instrument using peak/average detector mode.
3. Average test would be performed if the peak result were greater than the average limit.
4. Data of measurement within this frequency range shown " --- " in the table above means the reading of emissions are attenuated more than 20dB below the permissible limits or the field strength is too small to be measured.
5. Measurements above show only up to 6 maximum emissions noted, or would be lesser, with " N/A " remark, if no specific emissions from the EUT are recorded (ie: margin>20dB from the applicable limit) and considered that's already beyond the background noise floor.
6. Margin (dB) = Remark result (dBuV/m) – Average limit (dBuV/m).



Test Mode: TX / IEEE 802.11a / 5785MHz /(CH Mid)

Tested by: Fade Zhong

Ambient temperature: 24°C

Relative humidity: 52% RH

Date: August 24, 2017

Frequency (MHz)	Reading (dBuV)	Correction Factor (dB/m)	Result (dBuV/m)	Limit (dBuV/m)	Margin (dB)	Antenna Pole (V/H)	Remark
8124.000	31.83	9.58	41.41	74.00	-32.59	V	peak
11136.000	31.64	15.02	46.66	74.00	-27.34	V	peak
12492.000	30.14	16.27	46.41	74.00	-27.59	V	peak
13164.000	28.94	18.38	47.32	74.00	-26.68	V	peak
13800.000	31.07	20.05	51.12	74.00	-22.88	V	peak
14616.000	31.09	20.94	52.03	74.00	-21.97	V	peak
8388.000	31.99	9.44	41.43	74.00	-32.57	H	Peak
9468.000	30.76	10.45	41.21	74.00	-32.79	H	Peak
10644.000	30.83	13.98	44.81	74.00	-29.19	H	Peak
11460.000	30.89	14.88	45.77	74.00	-28.23	H	peak
13104.000	28.64	18.22	46.86	74.00	-27.14	H	peak
14412.000	31.19	20.82	52.01	74.00	-21.99	H	peak

**Remark:**

1. Measuring frequencies from 1 GHz to the 10th harmonic of highest fundamental frequency.
2. Radiated emissions measured in frequency above 1000MHz were made with an instrument using peak/average detector mode.
3. Average test would be performed if the peak result were greater than the average limit.
4. Data of measurement within this frequency range shown " --- " in the table above means the reading of emissions are attenuated more than 20dB below the permissible limits or the field strength is too small to be measured.
5. Measurements above show only up to 6 maximum emissions noted, or would be lesser, with " N/A " remark, if no specific emissions from the EUT are recorded (ie: margin>20dB from the applicable limit) and considered that's already beyond the background noise floor.
6. Margin (dB) = Remark result (dBuV/m) – Average limit (dBuV/m).



Test Mode: TX / IEEE 802.11a / 5825MHz /(CH High)

Tested by: Fade Zhong

Ambient temperature: 24°C Relative humidity: 52% RH

Date: August 24, 2017

Frequency (MHz)	Reading (dBuV)	Correction Factor (dB/m)	Result (dBuV/m)	Limit (dBuV/m)	Margin (dB)	Antenna Pole (V/H)	Remark
8124.000	31.76	9.58	41.34	74.00	-32.66	V	peak
9348.000	31.60	10.10	41.70	74.00	-32.30	V	peak
11148.000	31.43	15.01	46.44	74.00	-27.56	V	peak
11520.000	30.89	14.85	45.74	74.00	-28.26	V	peak
12660.000	29.73	16.82	46.55	74.00	-27.45	V	peak
14352.000	31.34	20.78	52.12	74.00	-21.88	V	peak
6444.000	32.99	6.80	39.79	74.00	-34.21	H	Peak
8112.000	32.33	9.59	41.92	74.00	-32.08	H	Peak
10740.000	30.38	14.27	44.65	74.00	-29.35	H	Peak
11388.000	30.94	14.91	45.85	74.00	-28.15	H	peak
12504.000	30.49	16.31	46.80	74.00	-27.20	H	peak
14292.000	31.63	20.75	52.38	74.00	-21.62	H	peak

**Remark:**

1. Measuring frequencies from 1 GHz to the 10th harmonic of highest fundamental frequency.
2. Radiated emissions measured in frequency above 1000MHz were made with an instrument using peak/average detector mode.
3. Average test would be performed if the peak result were greater than the average limit.
4. Data of measurement within this frequency range shown " --- " in the table above means the reading of emissions are attenuated more than 20dB below the permissible limits or the field strength is too small to be measured.
5. Measurements above show only up to 6 maximum emissions noted, or would be lesser, with " N/A " remark, if no specific emissions from the EUT are recorded (ie: margin>20dB from the applicable limit) and considered that's already beyond the background noise floor.
6. Margin (dB) = Remark result (dBuV/m) – Average limit (dBuV/m).



**Antenna 1**

**Test Mode:** TX / IEEE 802.11a / 5180MHz /(CH Low)

**Tested by:** Fade Zhong

**Ambient temperature:** 24°C **Relative humidity:** 52% RH

**Date:** August 24, 2017

Frequency (MHz)	Reading (dBuV)	Correction Factor (dB/m)	Result (dBuV/m)	Limit (dBuV/m)	Margin (dB)	Antenna Pole (V/H)	Remark
7932.000	31.44	9.52	40.96	74.00	-33.04	V	peak
8340.000	31.74	9.46	41.20	74.00	-32.80	V	peak
10356.000	31.00	13.08	44.08	74.00	-29.92	V	peak
11232.000	31.49	14.98	46.47	74.00	-27.53	V	peak
13080.000	29.75	18.16	47.91	74.00	-26.09	V	peak
15084.000	31.28	20.78	52.06	74.00	-21.94	V	peak
8388.000	31.83	9.44	41.27	74.00	-32.73	H	Peak
9348.000	31.33	10.10	41.43	74.00	-32.57	H	Peak
10608.000	30.59	13.86	44.45	74.00	-29.55	H	Peak
11520.000	31.72	14.85	46.57	74.00	-27.43	H	peak
12720.000	29.71	17.02	46.73	74.00	-27.27	H	peak
14352.000	31.38	20.78	52.16	74.00	-21.84	H	peak

**Remark:**

1. Measuring frequencies from 1 GHz to the 10th harmonic of highest fundamental frequency.
2. Radiated emissions measured in frequency above 1000MHz were made with an instrument using peak/average detector mode.
3. Average test would be performed if the peak result were greater than the average limit.
4. Data of measurement within this frequency range shown " --- " in the table above means the reading of emissions are attenuated more than 20dB below the permissible limits or the field strength is too small to be measured.
5. Measurements above show only up to 6 maximum emissions noted, or would be lesser, with " N/A " remark, if no specific emissions from the EUT are recorded (ie: margin>20dB from the applicable limit) and considered that's already beyond the background noise floor.
6. Margin (dB) = Remark result (dBuV/m) – Average limit (dBuV/m).



Test Mode: TX / IEEE 802.11a / 5200MHz /(CH Mid)

Tested by: Fade Zhong

Ambient temperature: 24°C

Relative humidity: 52% RH

Date: August 24, 2017

Frequency (MHz)	Reading (dBuV)	Correction Factor (dB/m)	Result (dBuV/m)	Limit (dBuV/m)	Margin (dB)	Antenna Pole (V/H)	Remark
7212.000	31.76	8.11	39.87	74.00	-34.13	V	peak
10020.000	31.10	12.04	43.14	74.00	-30.86	V	peak
11316.000	31.51	14.94	46.45	74.00	-27.55	V	peak
13152.000	28.78	18.35	47.13	74.00	-26.87	V	peak
14316.000	30.89	20.76	51.65	74.00	-22.35	V	peak
14796.000	31.46	21.04	52.50	74.00	-21.50	V	peak
8400.000	32.32	9.43	41.75	74.00	-32.25	H	Peak
10752.000	30.78	14.31	45.09	74.00	-28.91	H	Peak
11304.000	31.76	14.95	46.71	74.00	-27.29	H	Peak
13176.000	28.80	18.41	47.21	74.00	-26.79	H	peak
13788.000	31.19	20.02	51.21	74.00	-22.79	H	peak
14640.000	31.13	20.95	52.08	74.00	-21.92	H	peak

**Remark:**

1. Measuring frequencies from 1 GHz to the 10th harmonic of highest fundamental frequency.
2. Radiated emissions measured in frequency above 1000MHz were made with an instrument using peak/average detector mode.
3. Average test would be performed if the peak result were greater than the average limit.
4. Data of measurement within this frequency range shown " --- " in the table above means the reading of emissions are attenuated more than 20dB below the permissible limits or the field strength is too small to be measured.
5. Measurements above show only up to 6 maximum emissions noted, or would be lesser, with " N/A " remark, if no specific emissions from the EUT are recorded (ie: margin>20dB from the applicable limit) and considered that's already beyond the background noise floor.
6. Margin (dB) = Remark result (dBuV/m) – Average limit (dBuV/m).



Test Mode: TX / IEEE 802.11a / 5240MHz /(CH High)

Tested by: Fade Zhong

Ambient temperature: 24°C Relative humidity: 52% RH

Date: August 24, 2017

Frequency (MHz)	Reading (dBuV)	Correction Factor (dB/m)	Result (dBuV/m)	Limit (dBuV/m)	Margin (dB)	Antenna Pole (V/H)	Remark
8124.000	32.56	9.58	42.14	74.00	-31.86	V	peak
9384.000	31.52	10.21	41.73	74.00	-32.27	V	peak
11208.000	31.23	14.99	46.22	74.00	-27.78	V	peak
12828.000	29.22	17.38	46.60	74.00	-27.40	V	peak
13644.000	31.32	19.64	50.96	74.00	-23.04	V	peak
14472.000	31.03	20.85	51.88	74.00	-22.12	V	peak
8400.000	32.25	9.43	41.68	74.00	-32.32	H	Peak
10140.000	31.17	12.41	43.58	74.00	-30.42	H	Peak
11184.000	31.09	15.00	46.09	74.00	-27.91	H	Peak
12576.000	30.06	16.55	46.61	74.00	-27.39	H	peak
13104.000	29.20	18.22	47.42	74.00	-26.58	H	peak
14340.000	31.31	20.78	52.09	74.00	-21.91	H	peak

**Remark:**

1. Measuring frequencies from 1 GHz to the 10th harmonic of highest fundamental frequency.
2. Radiated emissions measured in frequency above 1000MHz were made with an instrument using peak/average detector mode.
3. Average test would be performed if the peak result were greater than the average limit.
4. Data of measurement within this frequency range shown " --- " in the table above means the reading of emissions are attenuated more than 20dB below the permissible limits or the field strength is too small to be measured.
5. Measurements above show only up to 6 maximum emissions noted, or would be lesser, with " N/A " remark, if no specific emissions from the EUT are recorded (ie: margin>20dB from the applicable limit) and considered that's already beyond the background noise floor.
6. Margin (dB) = Remark result (dBuV/m) – Average limit (dBuV/m).





Test Mode: TX / IEEE 802.11a / 5745MHz /(CH Low)

Tested by: Fade Zhong

Ambient temperature: 24°C Relative humidity: 52% RH

Date: August 24, 2017

Frequency (MHz)	Reading (dBuV)	Correction Factor (dB/m)	Result (dBuV/m)	Limit (dBuV/m)	Margin (dB)	Antenna Pole (V/H)	Remark
7944.000	32.41	9.54	41.95	74.00	-32.05	V	peak
8208.000	32.19	9.54	41.73	74.00	-32.27	V	peak
10272.000	30.70	12.82	43.52	74.00	-30.48	V	peak
11352.000	31.51	14.93	46.44	74.00	-27.56	V	peak
12684.000	30.26	16.90	47.16	74.00	-26.84	V	peak
14700.000	31.13	20.99	52.12	74.00	-21.88	V	peak
7980.000	31.95	9.61	41.56	74.00	-32.44	H	Peak
9600.000	30.54	10.83	41.37	74.00	-32.63	H	Peak
11172.000	31.37	15.00	46.37	74.00	-27.63	H	Peak
12744.000	29.90	17.10	47.00	74.00	-27.00	H	peak
13632.000	31.13	19.61	50.74	74.00	-23.26	H	peak
14388.000	31.20	20.81	52.01	74.00	-21.99	H	peak

**Remark:**

1. Measuring frequencies from 1 GHz to the 10th harmonic of highest fundamental frequency.
2. Radiated emissions measured in frequency above 1000MHz were made with an instrument using peak/average detector mode.
3. Average test would be performed if the peak result were greater than the average limit.
4. Data of measurement within this frequency range shown " --- " in the table above means the reading of emissions are attenuated more than 20dB below the permissible limits or the field strength is too small to be measured.
5. Measurements above show only up to 6 maximum emissions noted, or would be lesser, with " N/A " remark, if no specific emissions from the EUT are recorded (ie: margin>20dB from the applicable limit) and considered that's already beyond the background noise floor.
6. Margin (dB) = Remark result (dBuV/m) – Average limit (dBuV/m).



Test Mode: TX / IEEE 802.11a / 5785MHz /(CH Mid)

Tested by: Fade Zhong

Ambient temperature: 24°C

Relative humidity: 52% RH

Date: August 24, 2017

Frequency (MHz)	Reading (dBuV)	Correction Factor (dB/m)	Result (dBuV/m)	Limit (dBuV/m)	Margin (dB)	Antenna Pole (V/H)	Remark
8160.000	32.07	9.56	41.63	74.00	-32.37	V	peak
10128.000	31.27	12.38	43.65	74.00	-30.35	V	peak
11172.000	31.29	15.00	46.29	74.00	-27.71	V	peak
12612.000	29.88	16.67	46.55	74.00	-27.45	V	peak
13776.000	30.99	19.99	50.98	74.00	-23.02	V	peak
14292.000	30.78	20.75	51.53	74.00	-22.47	V	peak
8100.000	31.99	9.60	41.59	74.00	-32.41	H	Peak
10440.000	30.26	13.34	43.60	74.00	-30.40	H	Peak
11136.000	31.40	15.02	46.42	74.00	-27.58	H	Peak
13008.000	29.35	17.97	47.32	74.00	-26.68	H	peak
13800.000	31.03	20.05	51.08	74.00	-22.92	H	peak
14820.000	31.43	21.06	52.49	74.00	-21.51	H	peak

**Remark:**

1. Measuring frequencies from 1 GHz to the 10th harmonic of highest fundamental frequency.
2. Radiated emissions measured in frequency above 1000MHz were made with an instrument using peak/average detector mode.
3. Average test would be performed if the peak result were greater than the average limit.
4. Data of measurement within this frequency range shown " --- " in the table above means the reading of emissions are attenuated more than 20dB below the permissible limits or the field strength is too small to be measured.
5. Measurements above show only up to 6 maximum emissions noted, or would be lesser, with " N/A " remark, if no specific emissions from the EUT are recorded (ie: margin>20dB from the applicable limit) and considered that's already beyond the background noise floor.
6. Margin (dB) = Remark result (dBuV/m) – Average limit (dBuV/m).



Test Mode: TX / IEEE 802.11a / 5825MHz /(CH High)

Tested by: Fade Zhong

Ambient temperature: 24°C Relative humidity: 52% RH

Date: August 24, 2017

Frequency (MHz)	Reading (dBuV)	Correction Factor (dB/m)	Result (dBuV/m)	Limit (dBuV/m)	Margin (dB)	Antenna Pole (V/H)	Remark
8112.000	32.13	9.59	41.72	74.00	-32.28	V	peak
9756.000	30.35	11.28	41.63	74.00	-32.37	V	peak
10488.000	30.45	13.49	43.94	74.00	-30.06	V	peak
11148.000	31.72	15.01	46.73	74.00	-27.27	V	peak
11556.000	31.14	14.84	45.98	74.00	-28.02	V	peak
13248.000	29.70	18.60	48.30	74.00	-25.70	V	peak
8184.000	31.77	9.55	41.32	74.00	-32.68	H	Peak
9804.000	30.65	11.42	42.07	74.00	-31.93	H	Peak
11136.000	31.50	15.02	46.52	74.00	-27.48	H	Peak
12564.000	30.01	16.51	46.52	74.00	-27.48	H	peak
13596.000	31.20	19.52	50.72	74.00	-23.28	H	peak
14304.000	31.20	20.76	51.96	74.00	-22.04	H	peak

**Remark:**

1. Measuring frequencies from 1 GHz to the 10th harmonic of highest fundamental frequency.
2. Radiated emissions measured in frequency above 1000MHz were made with an instrument using peak/average detector mode.
3. Average test would be performed if the peak result were greater than the average limit.
4. Data of measurement within this frequency range shown " --- " in the table above means the reading of emissions are attenuated more than 20dB below the permissible limits or the field strength is too small to be measured.
5. Measurements above show only up to 6 maximum emissions noted, or would be lesser, with " N/A " remark, if no specific emissions from the EUT are recorded (ie: margin>20dB from the applicable limit) and considered that's already beyond the background noise floor.
6. Margin (dB) = Remark result (dBuV/m) – Average limit (dBuV/m).



**Combine with Antenna 0 and Antenna 1**

**Test Mode:** TX / IEEE 802.11n HT 20 MHz / 5180MHz /(CH Low) **Tested by:** Fade Zhong

**Ambient temperature:** 24°C **Relative humidity:** 52% RH **Date:** August 24, 2017

Frequency (MHz)	Reading (dBuV)	Correction Factor (dB/m)	Result (dBuV/m)	Limit (dBuV/m)	Margin (dB)	Antenna Pole (V/H)	Remark
8196.000	32.11	9.54	41.65	74.00	-32.35	V	peak
9840.000	31.05	11.52	42.57	74.00	-31.43	V	peak
11184.000	31.25	15.00	46.25	74.00	-27.75	V	peak
12588.000	30.34	16.59	46.93	74.00	-27.07	V	peak
13380.000	29.45	18.95	48.40	74.00	-25.60	V	peak
14424.000	31.64	20.83	52.47	74.00	-21.53	V	peak
8328.000	31.96	9.47	41.43	74.00	-32.57	H	Peak
9996.000	30.98	11.97	42.95	74.00	-31.05	H	Peak
11136.000	31.65	15.02	46.67	74.00	-27.33	H	Peak
12588.000	30.62	16.59	47.21	74.00	-26.79	H	peak
13680.000	30.76	19.74	50.50	74.00	-23.50	H	peak
14844.000	30.94	21.07	52.01	74.00	-21.99	H	peak

**Remark:**

1. Measuring frequencies from 1 GHz to the 10th harmonic of highest fundamental frequency.
2. Radiated emissions measured in frequency above 1000MHz were made with an instrument using peak/average detector mode.
3. Average test would be performed if the peak result were greater than the average limit.
4. Data of measurement within this frequency range shown " --- " in the table above means the reading of emissions are attenuated more than 20dB below the permissible limits or the field strength is too small to be measured.
5. Measurements above show only up to 6 maximum emissions noted, or would be lesser, with " N/A " remark, if no specific emissions from the EUT are recorded (ie: margin>20dB from the applicable limit) and considered that's already beyond the background noise floor.
6. Margin (dB) = Remark result (dBuV/m) – Average limit (dBuV/m).



**Test Mode:** TX / IEEE 802.11n HT 20 MHz / 5200MHz /(CH Mid) **Tested by:** Fade Zhong

**Ambient temperature:** 24°C **Relative humidity:** 52% RH **Date:** August 24, 2017

Frequency (MHz)	Reading (dBuV)	Correction Factor (dB/m)	Result (dBuV/m)	Limit (dBuV/m)	Margin (dB)	Antenna Pole (V/H)	Remark
7656.000	31.71	8.98	40.69	74.00	-33.31	V	peak
9396.000	31.27	10.24	41.51	74.00	-32.49	V	peak
10596.000	30.81	13.83	44.64	74.00	-29.36	V	peak
11160.000	31.59	15.01	46.60	74.00	-27.40	V	peak
13152.000	29.08	18.35	47.43	74.00	-26.57	V	peak
14316.000	31.38	20.76	52.14	74.00	-21.86	V	peak
8112.000	31.77	9.59	41.36	74.00	-32.64	H	Peak
9444.000	31.06	10.38	41.44	74.00	-32.56	H	Peak
10776.000	30.81	14.39	45.20	74.00	-28.80	H	Peak
11160.000	31.39	15.01	46.40	74.00	-27.60	H	peak
12372.000	30.19	15.87	46.06	74.00	-27.94	H	peak
14364.000	31.11	20.79	51.90	74.00	-22.10	H	peak

**Remark:**

1. Measuring frequencies from 1 GHz to the 10th harmonic of highest fundamental frequency.
2. Radiated emissions measured in frequency above 1000MHz were made with an instrument using peak/average detector mode.
3. Average test would be performed if the peak result were greater than the average limit.
4. Data of measurement within this frequency range shown " --- " in the table above means the reading of emissions are attenuated more than 20dB below the permissible limits or the field strength is too small to be measured.
5. Measurements above show only up to 6 maximum emissions noted, or would be lesser, with " N/A " remark, if no specific emissions from the EUT are recorded (ie: margin>20dB from the applicable limit) and considered that's already beyond the background noise floor.
6. Margin (dB) = Remark result (dBuV/m) – Average limit (dBuV/m).



**Test Mode:** TX / IEEE 802.11n HT 20 MHz / 5240MHz /(CH High) **Tested by:** Fade Zhong

**Ambient temperature:** 24°C **Relative humidity:** 52% RH **Date:** August 24, 2017

Frequency (MHz)	Reading (dBuV)	Correction Factor (dB/m)	Result (dBuV/m)	Limit (dBuV/m)	Margin (dB)	Antenna Pole (V/H)	Remark
8424.000	31.86	9.42	41.28	74.00	-32.72	V	peak
9900.000	31.15	11.69	42.84	74.00	-31.16	V	peak
11148.000	31.42	15.01	46.43	74.00	-27.57	V	peak
13092.000	29.11	18.19	47.30	74.00	-26.70	V	peak
14448.000	31.35	20.84	52.19	74.00	-21.81	V	peak
14916.000	30.91	21.11	52.02	74.00	-21.98	V	peak
8184.000	31.73	9.55	41.28	74.00	-32.72	H	Peak
10056.000	30.74	12.15	42.89	74.00	-31.11	H	Peak
11208.000	32.07	14.99	47.06	74.00	-26.94	H	Peak
12996.000	29.19	17.94	47.13	74.00	-26.87	H	peak
13776.000	30.95	19.99	50.94	74.00	-23.06	H	peak
14376.000	31.24	20.80	52.04	74.00	-21.96	H	peak

**Remark:**

1. Measuring frequencies from 1 GHz to the 10th harmonic of highest fundamental frequency.
2. Radiated emissions measured in frequency above 1000MHz were made with an instrument using peak/average detector mode.
3. Average test would be performed if the peak result were greater than the average limit.
4. Data of measurement within this frequency range shown " --- " in the table above means the reading of emissions are attenuated more than 20dB below the permissible limits or the field strength is too small to be measured.
5. Measurements above show only up to 6 maximum emissions noted, or would be lesser, with " N/A " remark, if no specific emissions from the EUT are recorded (ie: margin>20dB from the applicable limit) and considered that's already beyond the background noise floor.
6. Margin (dB) = Remark result (dBuV/m) – Average limit (dBuV/m).



**Test Mode:** TX / IEEE 802.11n HT 20 MHz / 5745MHz / (CH Low) **Tested by:** Fade Zhong

**Ambient temperature:** 24°C **Relative humidity:** 52% RH **Date:** August 24, 2017

Frequency (MHz)	Reading (dBuV)	Correction Factor (dB/m)	Result (dBuV/m)	Limit (dBuV/m)	Margin (dB)	Antenna Pole (V/H)	Remark
7680.000	31.74	9.03	40.77	74.00	-33.23	V	peak
8412.000	32.34	9.42	41.76	74.00	-32.24	V	peak
9876.000	31.07	11.62	42.69	74.00	-31.31	V	peak
11148.000	31.46	15.01	46.47	74.00	-27.53	V	peak
13500.000	29.26	19.27	48.53	74.00	-25.47	V	peak
14340.000	31.13	20.78	51.91	74.00	-22.09	V	peak
9336.000	31.17	10.07	41.24	74.00	-32.76	H	Peak
11160.000	31.90	15.01	46.91	74.00	-27.09	H	Peak
11496.000	31.43	14.86	46.29	74.00	-27.71	H	Peak
13284.000	28.99	18.70	47.69	74.00	-26.31	H	peak
14028.000	30.35	20.60	50.95	74.00	-23.05	H	peak
14316.000	31.63	20.76	52.39	74.00	-21.61	H	peak

**Remark:**

1. Measuring frequencies from 1 GHz to the 10th harmonic of highest fundamental frequency.
2. Radiated emissions measured in frequency above 1000MHz were made with an instrument using peak/average detector mode.
3. Average test would be performed if the peak result were greater than the average limit.
4. Data of measurement within this frequency range shown " --- " in the table above means the reading of emissions are attenuated more than 20dB below the permissible limits or the field strength is too small to be measured.
5. Measurements above show only up to 6 maximum emissions noted, or would be lesser, with " N/A " remark, if no specific emissions from the EUT are recorded (ie: margin>20dB from the applicable limit) and considered that's already beyond the background noise floor.
6. Margin (dB) = Remark result (dBuV/m) – Average limit (dBuV/m).



Test Mode: TX / IEEE 802.11n HT 20 MHz / 5785MHz /(CH Mid) Tested by: Fade Zhong

Ambient temperature: 24°C Relative humidity: 52% RH Date: August 24, 2017

Frequency (MHz)	Reading (dBuV)	Correction Factor (dB/m)	Result (dBuV/m)	Limit (dBuV/m)	Margin (dB)	Antenna Pole (V/H)	Remark
8412.000	32.13	9.42	41.55	74.00	-32.45	V	peak
10044.000	30.80	12.12	42.92	74.00	-31.08	V	peak
10800.000	30.64	14.46	45.10	74.00	-28.90	V	peak
11496.000	31.99	14.86	46.85	74.00	-27.15	V	peak
13308.000	28.97	18.76	47.73	74.00	-26.27	V	peak
14544.000	31.11	20.90	52.01	74.00	-21.99	V	peak
7980.000	31.62	9.61	41.23	74.00	-32.77	H	Peak
9348.000	31.62	10.10	41.72	74.00	-32.28	H	Peak
11148.000	31.51	15.01	46.52	74.00	-27.48	H	Peak
12660.000	29.77	16.82	46.59	74.00	-27.41	H	peak
13332.000	28.98	18.82	47.80	74.00	-26.20	H	peak
14508.000	31.45	20.87	52.32	74.00	-21.68	H	peak

**Remark:**

1. Measuring frequencies from 1 GHz to the 10th harmonic of highest fundamental frequency.
2. Radiated emissions measured in frequency above 1000MHz were made with an instrument using peak/average detector mode.
3. Average test would be performed if the peak result were greater than the average limit.
4. Data of measurement within this frequency range shown " --- " in the table above means the reading of emissions are attenuated more than 20dB below the permissible limits or the field strength is too small to be measured.
5. Measurements above show only up to 6 maximum emissions noted, or would be lesser, with " N/A " remark, if no specific emissions from the EUT are recorded (ie: margin>20dB from the applicable limit) and considered that's already beyond the background noise floor.
6. Margin (dB) = Remark result (dBuV/m) – Average limit (dBuV/m).





**Test Mode:** TX / IEEE 802.11n HT 20 MHz / 5825MHz / (CH High) **Tested by:** Fade Zhong

**Ambient temperature:** 24°C **Relative humidity:** 52% RH **Date:** August 24, 2017

Frequency (MHz)	Reading (dBuV)	Correction Factor (dB/m)	Result (dBuV/m)	Limit (dBuV/m)	Margin (dB)	Antenna Pole (V/H)	Remark
8040.000	31.96	9.63	41.59	74.00	-32.41	V	peak
9240.000	31.63	9.79	41.42	74.00	-32.58	V	peak
11136.000	31.72	15.02	46.74	74.00	-27.26	V	peak
12624.000	29.79	16.71	46.50	74.00	-27.50	V	peak
13380.000	28.98	18.95	47.93	74.00	-26.07	V	peak
14520.000	31.24	20.88	52.12	74.00	-21.88	V	peak
8412.000	31.62	9.42	41.04	74.00	-32.96	H	Peak
9576.000	30.22	10.76	40.98	74.00	-33.02	H	Peak
10500.000	29.85	13.53	43.38	74.00	-30.62	H	Peak
11136.000	30.92	15.02	45.94	74.00	-28.06	H	peak
12744.000	29.39	17.10	46.49	74.00	-27.51	H	peak
14328.000	30.95	20.77	51.72	74.00	-22.28	H	peak

**Remark:**

1. Measuring frequencies from 1 GHz to the 10th harmonic of highest fundamental frequency.
2. Radiated emissions measured in frequency above 1000MHz were made with an instrument using peak/average detector mode.
3. Average test would be performed if the peak result were greater than the average limit.
4. Data of measurement within this frequency range shown " --- " in the table above means the reading of emissions are attenuated more than 20dB below the permissible limits or the field strength is too small to be measured.
5. Measurements above show only up to 6 maximum emissions noted, or would be lesser, with " N/A " remark, if no specific emissions from the EUT are recorded (ie: margin>20dB from the applicable limit) and considered that's already beyond the background noise floor.
6. Margin (dB) = Remark result (dBuV/m) – Average limit (dBuV/m).



**Combine with Antenna 0 and Antenna 1**

**Test Mode:** TX / IEEE 802.11n HT 40 MHz / 5190MHz / (CH Low) **Tested by:** Fade Zhong

**Ambient temperature:** 24°C **Relative humidity:** 52% RH **Date:** August 24, 2017

Frequency (MHz)	Reading (dBuV)	Correction Factor (dB/m)	Result (dBuV/m)	Limit (dBuV/m)	Margin (dB)	Antenna Pole (V/H)	Remark
7464.000	31.56	8.60	40.16	74.00	-33.84	V	peak
8424.000	31.91	9.42	41.33	74.00	-32.67	V	peak
10128.000	30.57	12.38	42.95	74.00	-31.05	V	peak
10644.000	30.49	13.98	44.47	74.00	-29.53	V	peak
12360.000	29.55	15.83	45.38	74.00	-28.62	V	peak
14448.000	31.18	20.84	52.02	74.00	-21.98	V	peak
8364.000	32.02	9.45	41.47	74.00	-32.53	H	Peak
10020.000	31.13	12.04	43.17	74.00	-30.83	H	Peak
11304.000	31.44	14.95	46.39	74.00	-27.61	H	Peak
12684.000	29.47	16.90	46.37	74.00	-27.63	H	peak
13416.000	28.59	19.04	47.63	74.00	-26.37	H	peak
14616.000	30.95	20.94	51.89	74.00	-22.11	H	peak

**Remark:**

1. Measuring frequencies from 1 GHz to the 10th harmonic of highest fundamental frequency.
2. Radiated emissions measured in frequency above 1000MHz were made with an instrument using peak/average detector mode.
3. Average test would be performed if the peak result were greater than the average limit.
4. Data of measurement within this frequency range shown " --- " in the table above means the reading of emissions are attenuated more than 20dB below the permissible limits or the field strength is too small to be measured.
5. Measurements above show only up to 6 maximum emissions noted, or would be lesser, with " N/A " remark, if no specific emissions from the EUT are recorded (ie: margin>20dB from the applicable limit) and considered that's already beyond the background noise floor.
6. Margin (dB) = Remark result (dBuV/m) – Average limit (dBuV/m).



**Test Mode:** TX / IEEE 802.11n HT 40 MHz / 5230MHz /(CH High) **Tested by:** Fade Zhong

**Ambient temperature:** 24°C **Relative humidity:** 52% RH **Date:** August 24, 2017

Frequency (MHz)	Reading (dBuV)	Correction Factor (dB/m)	Result (dBuV/m)	Limit (dBuV/m)	Margin (dB)	Antenna Pole (V/H)	Remark
8508.000	31.62	9.37	40.99	74.00	-33.01	V	peak
10020.000	31.19	12.04	43.23	74.00	-30.77	V	peak
11508.000	31.12	14.86	45.98	74.00	-28.02	V	peak
12588.000	29.97	16.59	46.56	74.00	-27.44	V	peak
13932.000	30.77	20.40	51.17	74.00	-22.83	V	peak
14544.000	31.07	20.90	51.97	74.00	-22.03	V	peak
7992.000	32.39	9.63	42.02	74.00	-31.98	H	Peak
9384.000	31.44	10.21	41.65	74.00	-32.35	H	Peak
10476.000	30.40	13.46	43.86	74.00	-30.14	H	Peak
11244.000	31.36	14.97	46.33	74.00	-27.67	H	peak
12624.000	29.81	16.71	46.52	74.00	-27.48	H	peak
14292.000	31.13	20.75	51.88	74.00	-22.12	H	peak

**Remark:**

1. Measuring frequencies from 1 GHz to the 10th harmonic of highest fundamental frequency.
2. Radiated emissions measured in frequency above 1000MHz were made with an instrument using peak/average detector mode.
3. Average test would be performed if the peak result were greater than the average limit.
4. Data of measurement within this frequency range shown " --- " in the table above means the reading of emissions are attenuated more than 20dB below the permissible limits or the field strength is too small to be measured.
5. Measurements above show only up to 6 maximum emissions noted, or would be lesser, with " N/A " remark, if no specific emissions from the EUT are recorded (ie: margin>20dB from the applicable limit) and considered that's already beyond the background noise floor.
6. Margin (dB) = Remark result (dBuV/m) – Average limit (dBuV/m).



**Test Mode:** TX / IEEE 802.11n HT 40 MHz / 5755MHz /(CH Low) **Tested by:** Fade Zhong

**Ambient temperature:** 24°C **Relative humidity:** 52% RH **Date:** August 24, 2017

Frequency (MHz)	Reading (dBuV)	Correction Factor (dB/m)	Result (dBuV/m)	Limit (dBuV/m)	Margin (dB)	Antenna Pole (V/H)	Remark
7968.000	32.46	9.59	42.05	74.00	-31.95	V	peak
10032.000	31.09	12.08	43.17	74.00	-30.83	V	peak
11136.000	31.11	15.02	46.13	74.00	-27.87	V	peak
12144.000	30.84	15.12	45.96	74.00	-28.04	V	peak
13104.000	29.29	18.22	47.51	74.00	-26.49	V	peak
14340.000	31.46	20.78	52.24	74.00	-21.76	V	peak
8424.000	31.53	9.42	40.95	74.00	-33.05	H	Peak
10800.000	30.68	14.46	45.14	74.00	-28.86	H	Peak
11148.000	31.74	15.01	46.75	74.00	-27.25	H	Peak
12540.000	29.80	16.43	46.23	74.00	-27.77	H	peak
13260.000	29.04	18.63	47.67	74.00	-26.33	H	peak
14364.000	30.87	20.79	51.66	74.00	-22.34	H	peak

**Remark:**

1. Measuring frequencies from 1 GHz to the 10th harmonic of highest fundamental frequency.
2. Radiated emissions measured in frequency above 1000MHz were made with an instrument using peak/average detector mode.
3. Average test would be performed if the peak result were greater than the average limit.
4. Data of measurement within this frequency range shown " --- " in the table above means the reading of emissions are attenuated more than 20dB below the permissible limits or the field strength is too small to be measured.
5. Measurements above show only up to 6 maximum emissions noted, or would be lesser, with " N/A " remark, if no specific emissions from the EUT are recorded (ie: margin>20dB from the applicable limit) and considered that's already beyond the background noise floor.
6. Margin (dB) = Remark result (dBuV/m) – Average limit (dBuV/m).



**Test Mode:** TX / IEEE 802.11n HT 40 MHz / 5795MHz /(CH High) **Tested by:** Fade Zhong

**Ambient temperature:** 24°C **Relative humidity:** 52% RH **Date:** August 24, 2017

Frequency (MHz)	Reading (dBuV)	Correction Factor (dB/m)	Result (dBuV/m)	Limit (dBuV/m)	Margin (dB)	Antenna Pole (V/H)	Remark
7044.000	32.11	7.79	39.90	74.00	-34.10	V	peak
8160.000	32.35	9.56	41.91	74.00	-32.09	V	peak
9876.000	30.78	11.62	42.40	74.00	-31.60	V	peak
11148.000	31.15	15.01	46.16	74.00	-27.84	V	peak
13128.000	29.09	18.29	47.38	74.00	-26.62	V	peak
14352.000	31.19	20.78	51.97	74.00	-22.03	V	peak
6984.000	32.42	7.67	40.09	74.00	-33.91	H	Peak
8136.000	31.95	9.58	41.53	74.00	-32.47	H	Peak
9900.000	30.26	11.69	41.95	74.00	-32.05	H	Peak
11148.000	31.22	15.01	46.23	74.00	-27.77	H	peak
12552.000	30.16	16.47	46.63	74.00	-27.37	H	peak
14724.000	31.08	21.00	52.08	74.00	-21.92	H	peak

**Remark:**

1. Measuring frequencies from 1 GHz to the 10th harmonic of highest fundamental frequency.
2. Radiated emissions measured in frequency above 1000MHz were made with an instrument using peak/average detector mode.
3. Average test would be performed if the peak result were greater than the average limit.
4. Data of measurement within this frequency range shown " --- " in the table above means the reading of emissions are attenuated more than 20dB below the permissible limits or the field strength is too small to be measured.
5. Measurements above show only up to 6 maximum emissions noted, or would be lesser, with " N/A " remark, if no specific emissions from the EUT are recorded (ie: margin>20dB from the applicable limit) and considered that's already beyond the background noise floor.
6. Margin (dB) = Remark result (dBuV/m) – Average limit (dBuV/m).



**Combine with Antenna 0 and Antenna 1**

**Test Mode:** TX / IEEE 802. 11ac 80 / 5210MHz /(CH Low)

**Tested by:** Fade Zhong

**Ambient temperature:** 24°C **Relative humidity:** 52% RH

**Date:** August 24, 2017

Frequency (MHz)	Reading (dBuV)	Correction Factor (dB/m)	Result (dBuV/m)	Limit (dBuV/m)	Margin (dB)	Antenna Pole (V/H)	Remark
6960.000	32.23	7.64	39.87	74.00	-34.13	V	peak
8400.000	31.96	9.43	41.39	74.00	-32.61	V	peak
10908.000	30.82	14.79	45.61	74.00	-28.39	V	peak
11136.000	31.10	15.02	46.12	74.00	-27.88	V	peak
13056.000	29.04	18.10	47.14	74.00	-26.86	V	peak
14352.000	31.15	20.78	51.93	74.00	-22.07	V	peak
7644.000	32.02	8.96	40.98	74.00	-33.02	H	Peak
8376.000	32.24	9.44	41.68	74.00	-32.32	H	Peak
10140.000	30.82	12.41	43.23	74.00	-30.77	H	Peak
11160.000	31.11	15.01	46.12	74.00	-27.88	H	peak
12528.000	29.79	16.39	46.18	74.00	-27.82	H	peak
14388.000	30.97	20.81	51.78	74.00	-22.22	H	peak

**Remark:**

1. Measuring frequencies from 1 GHz to the 10th harmonic of highest fundamental frequency.
2. Radiated emissions measured in frequency above 1000MHz were made with an instrument using peak/average detector mode.
3. Average test would be performed if the peak result were greater than the average limit.
4. Data of measurement within this frequency range shown " --- " in the table above means the reading of emissions are attenuated more than 20dB below the permissible limits or the field strength is too small to be measured.
5. Measurements above show only up to 6 maximum emissions noted, or would be lesser, with " N/A " remark, if no specific emissions from the EUT are recorded (ie: margin>20dB from the applicable limit) and considered that's already beyond the background noise floor.
6. Margin (dB) = Remark result (dBuV/m) – Average limit (dBuV/m).



Test Mode: TX / IEEE 802.11ac 80 / 5775MHz

Tested by: Fade Zhong

Ambient temperature: 24°C Relative humidity: 52% RH

Date: August 24, 2017

Frequency (MHz)	Reading (dBuV)	Correction Factor (dB/m)	Result (dBuV/m)	Limit (dBuV/m)	Margin (dB)	Antenna Pole (V/H)	Remark
6276.000	41.19	6.53	47.72	74.00	-26.28	V	peak
8076.000	32.37	9.61	41.98	74.00	-32.02	V	peak
10416.000	30.21	13.27	43.48	74.00	-30.52	V	peak
11196.000	31.49	14.99	46.48	74.00	-27.52	V	peak
13644.000	31.00	19.64	50.64	74.00	-23.36	V	peak
14364.000	31.31	20.79	52.10	74.00	-21.90	V	peak
8100.000	31.91	9.60	41.51	74.00	-32.49	H	Peak
9384.000	31.65	10.21	41.86	74.00	-32.14	H	Peak
10356.000	30.75	13.08	43.83	74.00	-30.17	H	Peak
11232.000	31.60	14.98	46.58	74.00	-27.42	H	peak
13080.000	29.13	18.16	47.29	74.00	-26.71	H	peak
14352.000	31.75	20.78	52.53	74.00	-21.47	H	peak

**Remark:**

1. Measuring frequencies from 1 GHz to the 10th harmonic of highest fundamental frequency.
2. Radiated emissions measured in frequency above 1000MHz were made with an instrument using peak/average detector mode.
3. Average test would be performed if the peak result were greater than the average limit.
4. Data of measurement within this frequency range shown " --- " in the table above means the reading of emissions are attenuated more than 20dB below the permissible limits or the field strength is too small to be measured.
5. Measurements above show only up to 6 maximum emissions noted, or would be lesser, with " N/A " remark, if no specific emissions from the EUT are recorded (ie: margin>20dB from the applicable limit) and considered that's already beyond the background noise floor.
6. Margin (dB) = Remark result (dBuV/m) – Average limit (dBuV/m).



## 6.8 CONDUCTED UNDESIRABLE EMISSION

### 6.8.1 LIMIT

According to 15.407(b),

- (1) For transmitters operating in the 5.15-5.25 GHz band: all emissions outside of the 5.15-5.35 GHz band shall not exceed an EIRP of -27 dBm/MHz.
- (2) All emissions shall be limited to a level of -27 dBm/MHz at 75 MHz or more above or below the band edge increasing linearly to 10 dBm/MHz at 25 MHz above or below the band edge, and from 25 MHz above or below the band edge increasing linearly to a level of 15.6 dBm/MHz at 5 MHz above or below the band edge, and from 5 MHz above or below the band edge increasing linearly to a level of 27 dBm/MHz at the band edge.
- (3) The provisions of §15.205 apply to intentional radiators operating under this section.

### 6.8.2 MEASUREMENT EQUIPMENT USED

Name of Equipment	Manufacturer	Model	Serial Number	Last Calibration	Due Calibration
Spectrum Analyzer	Agilent	N9010A	MY52221469	02/21/2017	02/20/2018

*Remark: Each piece of equipment is scheduled for calibration once a year.*

### 6.8.3 TEST CONFIGURATION

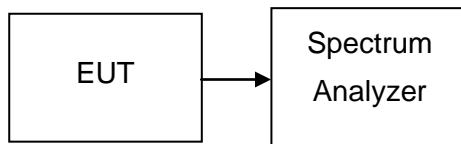

### 6.8.4 TEST PROCEDURE

Conducted RF measurements of the transmitter output were made to confirm that the EUT antenna port conducted emissions meet the specified limit and to identify any spurious signals that require further investigation or measurements on the radiated emissions site.

The transmitter output is connected to the spectrum analyzer. The resolution bandwidth is set to 1MHz. The video bandwidth is set to 3MHz. Peak detection measurements are compared to the average EIRP limit, adjusted for the maximum antenna gain. If necessary, additional average detection measurements are made.

Measurements are made over the 30 MHz to 40 GHz range with the transmitter set to the lowest, middle, and highest channels.





### 6.8.5 TEST RESULTS

No non-compliance noted

#### Test Plot

#### Antenna 0

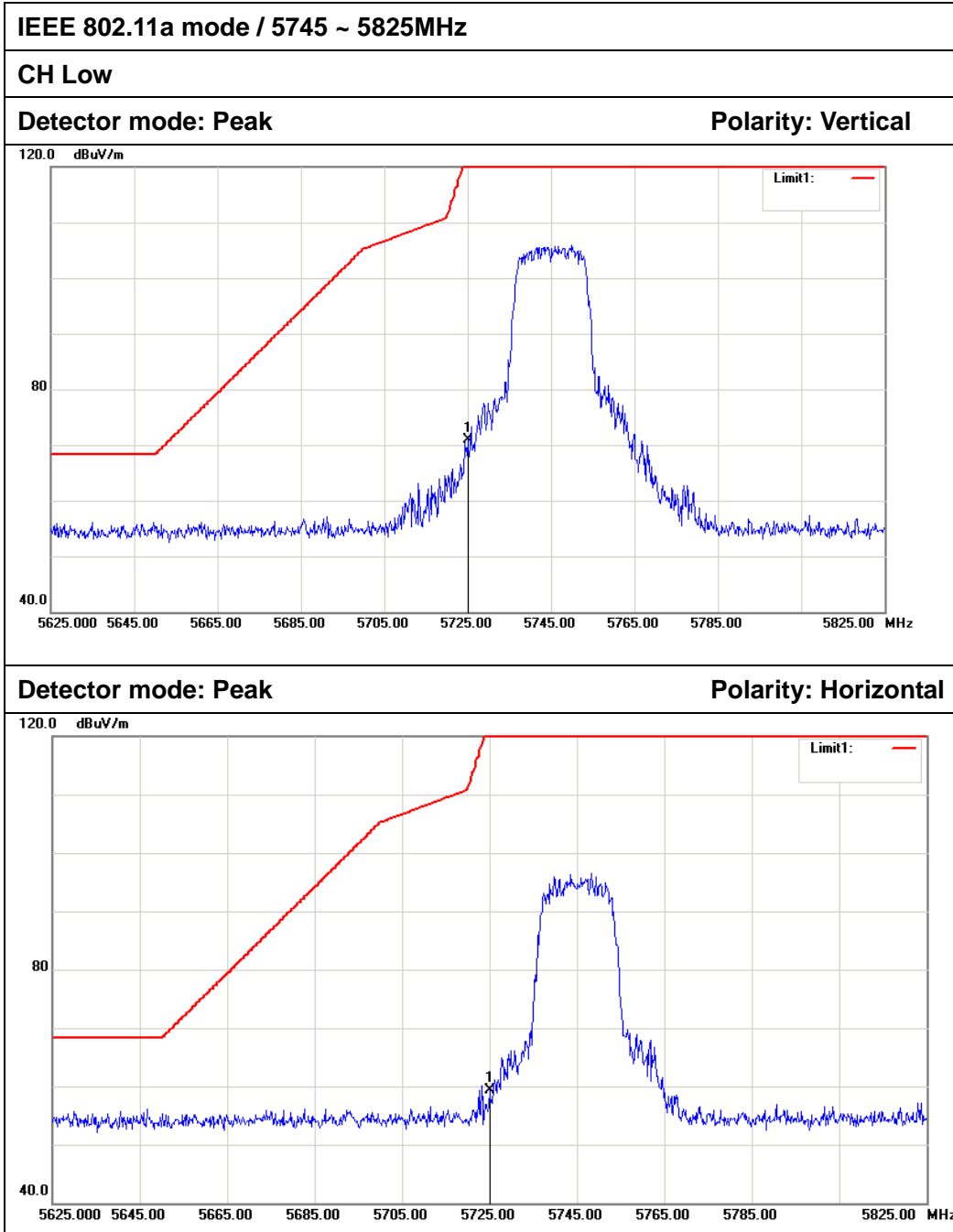

No.	Frequency (MHz)	Reading (dB)	Factor (dB/m)	Result (dB/m)	Limit (dB/m)	Margin (dB)	Remark	Antenna Polar
1	5725.000	65.01	5.96	70.97	122.20	-51.23	Peak	Vertical
2	5725.000	53.35	5.96	59.31	122.20	-62.89	Peak	Horizontal

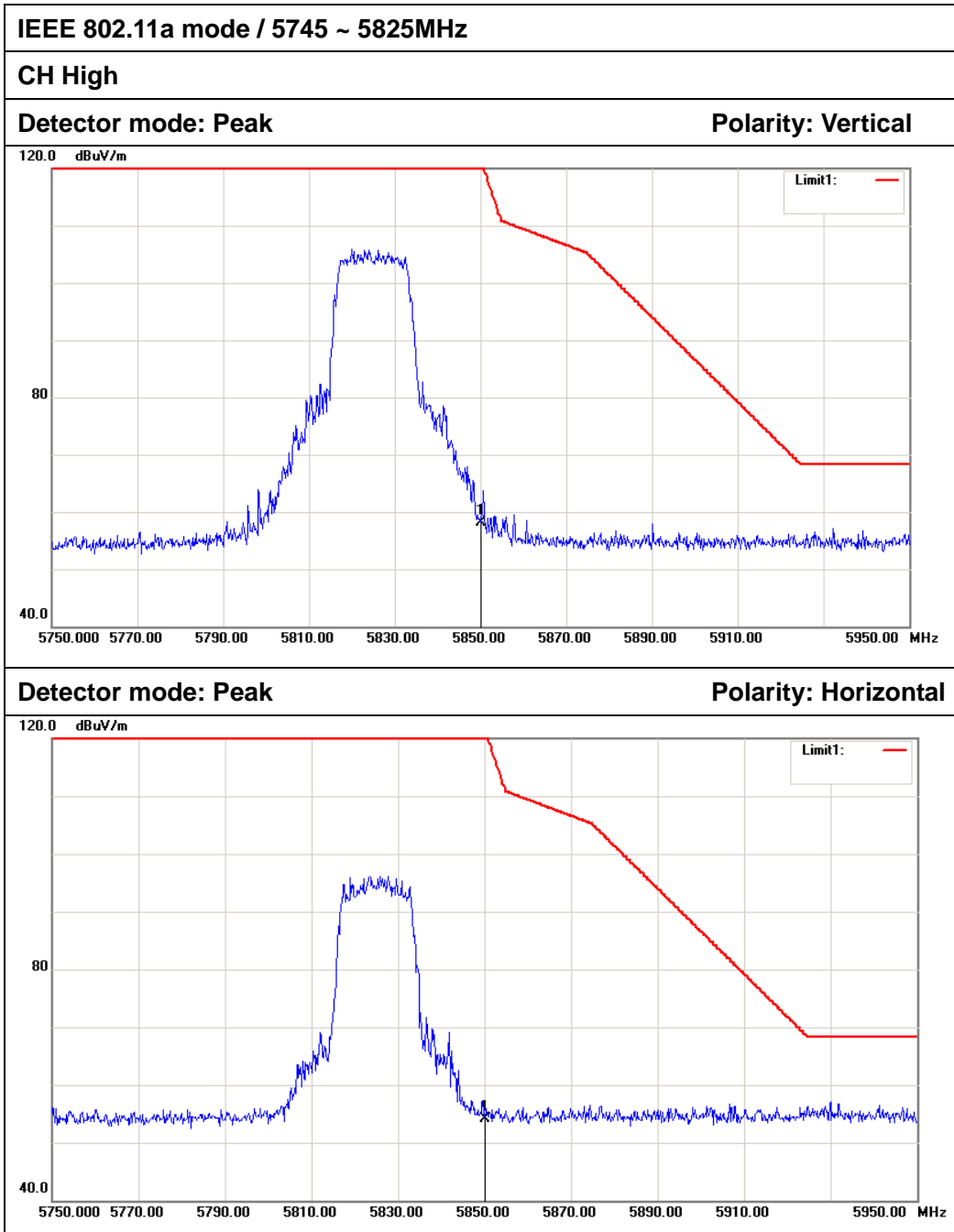

No.	Frequency (MHz)	Reading (dB)	Factor (dB/m)	Result (dB/m)	Limit (dB/m)	Margin (dB)	Remark	Antenna Polar
1	5850.000	52.14	6.02	58.16	122.20	-64.04	Peak	Vertical
2	5850.000	48.10	6.02	54.12	122.20	-68.08	Peak	Horizontal



Antenna 1

IEEE 802.11a mode / 5745 ~ 5825MHz

CH Low

Detector mode: Peak

Polarity: Vertical

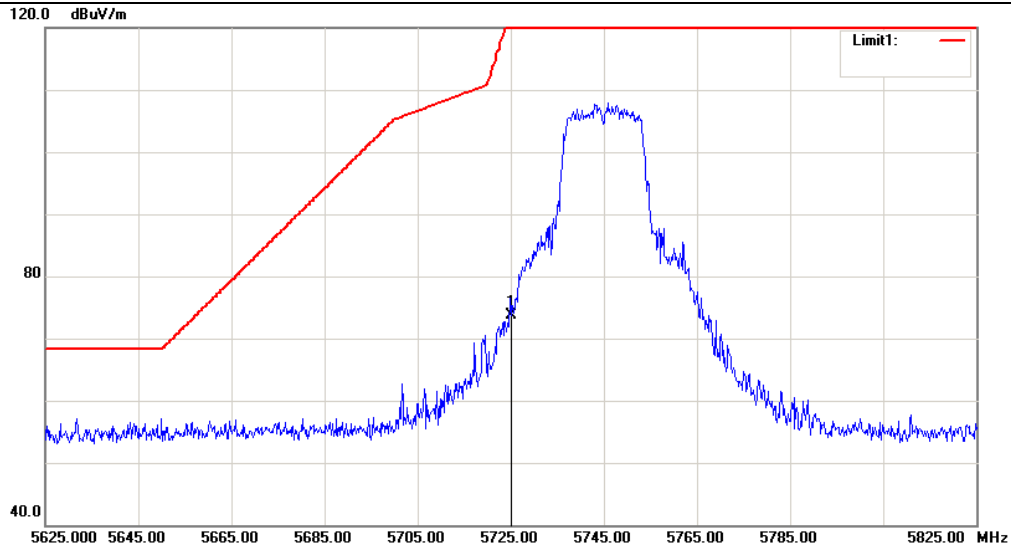

Detector mode: Peak

Polarity: Horizontal

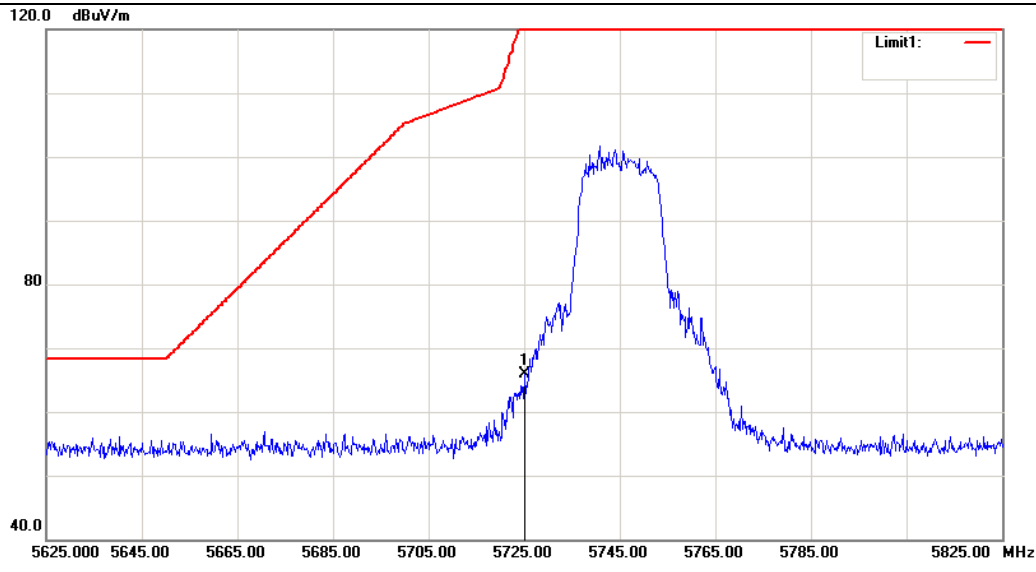

No.	Frequency (MHz)	Reading (dB)	Factor (dB/m)	Result (dB/m)	Limit (dB/m)	Margin (dB)	Remark	Antenna Polar
1	5725.000	67.73	5.96	73.69	122.20	-48.51	Peak	Vertical
2	5725.000	59.85	5.96	65.81	122.20	-56.39	Peak	Horizontal

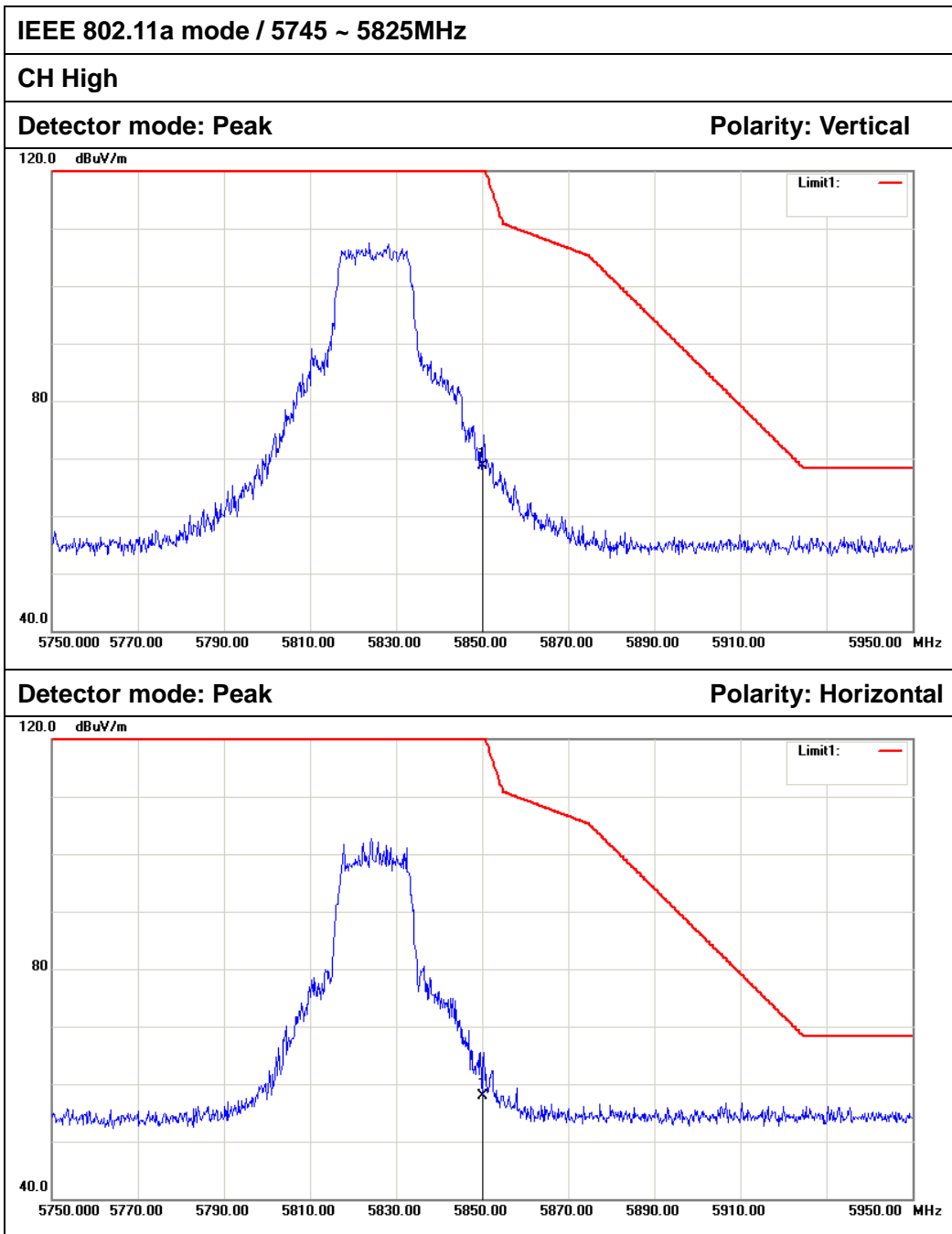

No.	Frequency (MHz)	Reading (dB)	Factor (dB/m)	Result (dB/m)	Limit (dB/m)	Margin (dB)	Remark	Antenna Polar
1	5850.000	62.76	6.02	68.78	122.20	-53.42	Peak	Vertical
2	5850.000	51.93	6.02	57.95	122.20	-64.25	Peak	Horizontal



Combine with Antenna 0 and Antenna 1

IEEE 802.11n HT 20 MHz mode / 5745 ~ 5825MHz

CH Low

Detector mode: Peak

Polarity: Vertical

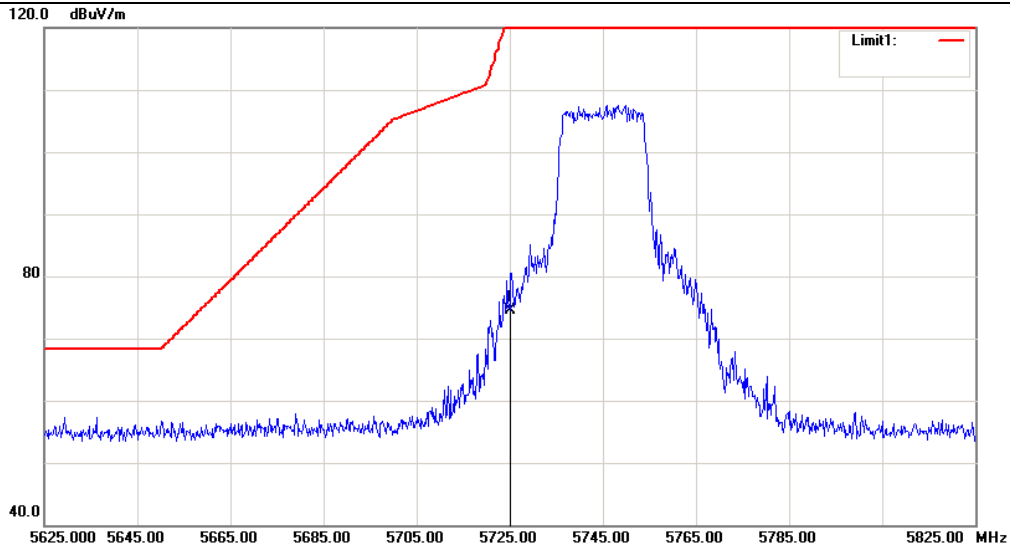

Detector mode: Peak

Polarity: Horizontal

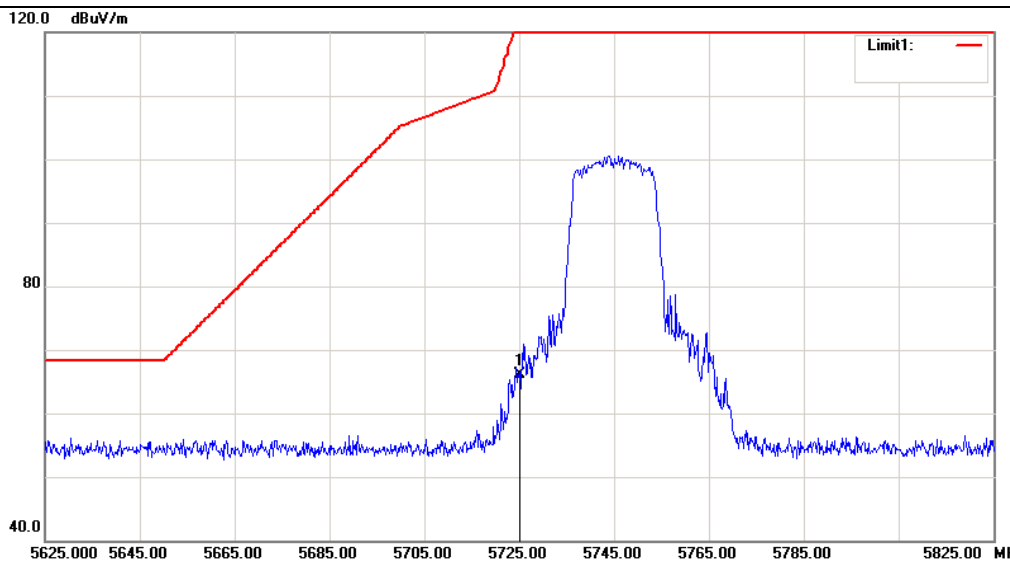

No.	Frequency (MHz)	Reading (dB)	Factor (dB/m)	Result (dB/m)	Limit (dB/m)	Margin (dB)	Remark	Antenna Polar
1	5725.000	68.53	5.96	74.49	122.20	-47.71	Peak	Vertical
2	5725.000	60.21	5.96	66.17	122.20	-56.03	Peak	Horizontal

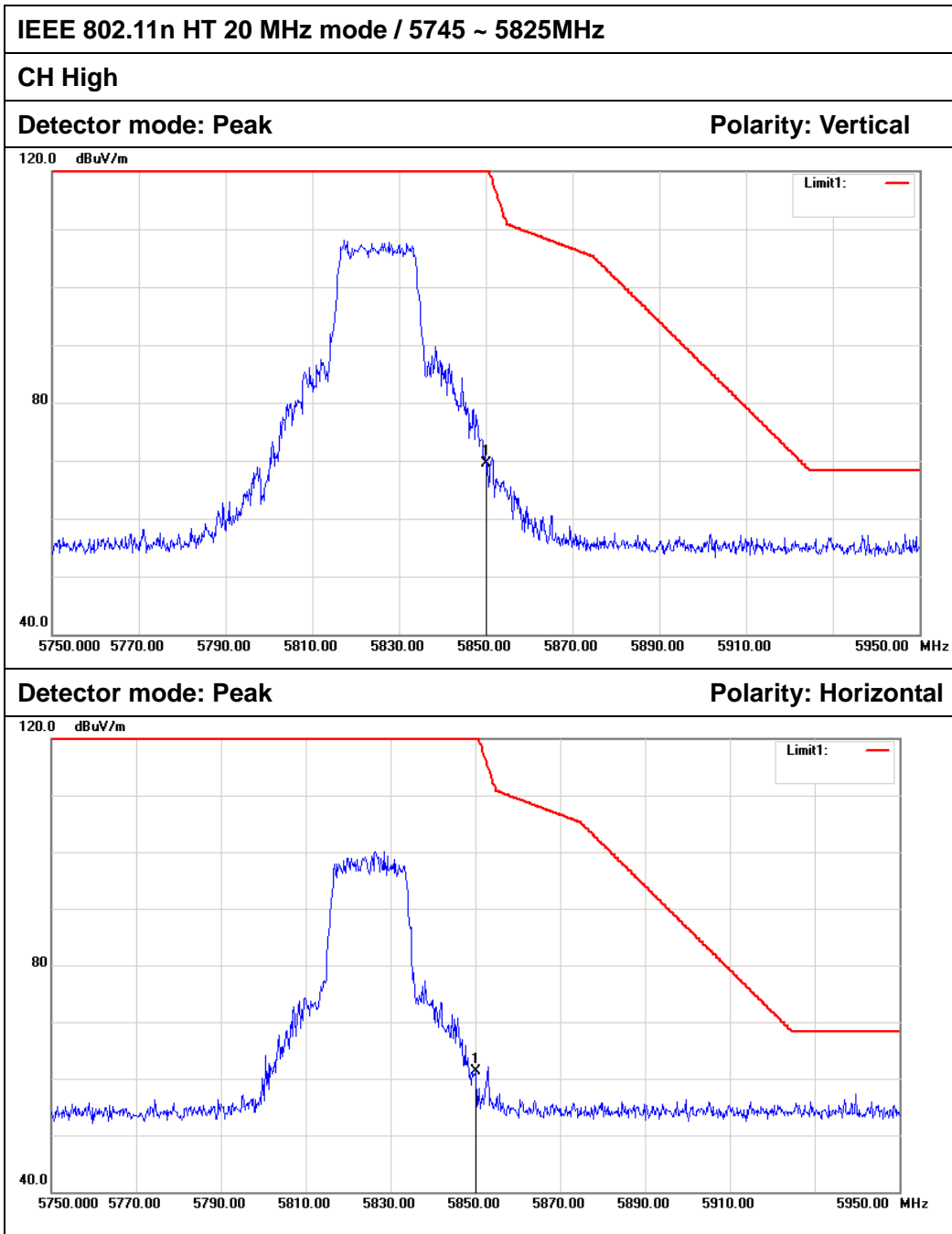

No.	Frequency (MHz)	Reading (dB)	Factor (dB/m)	Result (dB/m)	Limit (dB/m)	Margin (dB)	Remark	Antenna Polar
1	5850.000	63.55	6.02	69.57	122.20	-52.63	Peak	Vertical
2	5850.000	55.18	6.02	61.20	122.20	-61.00	Peak	Horizontal

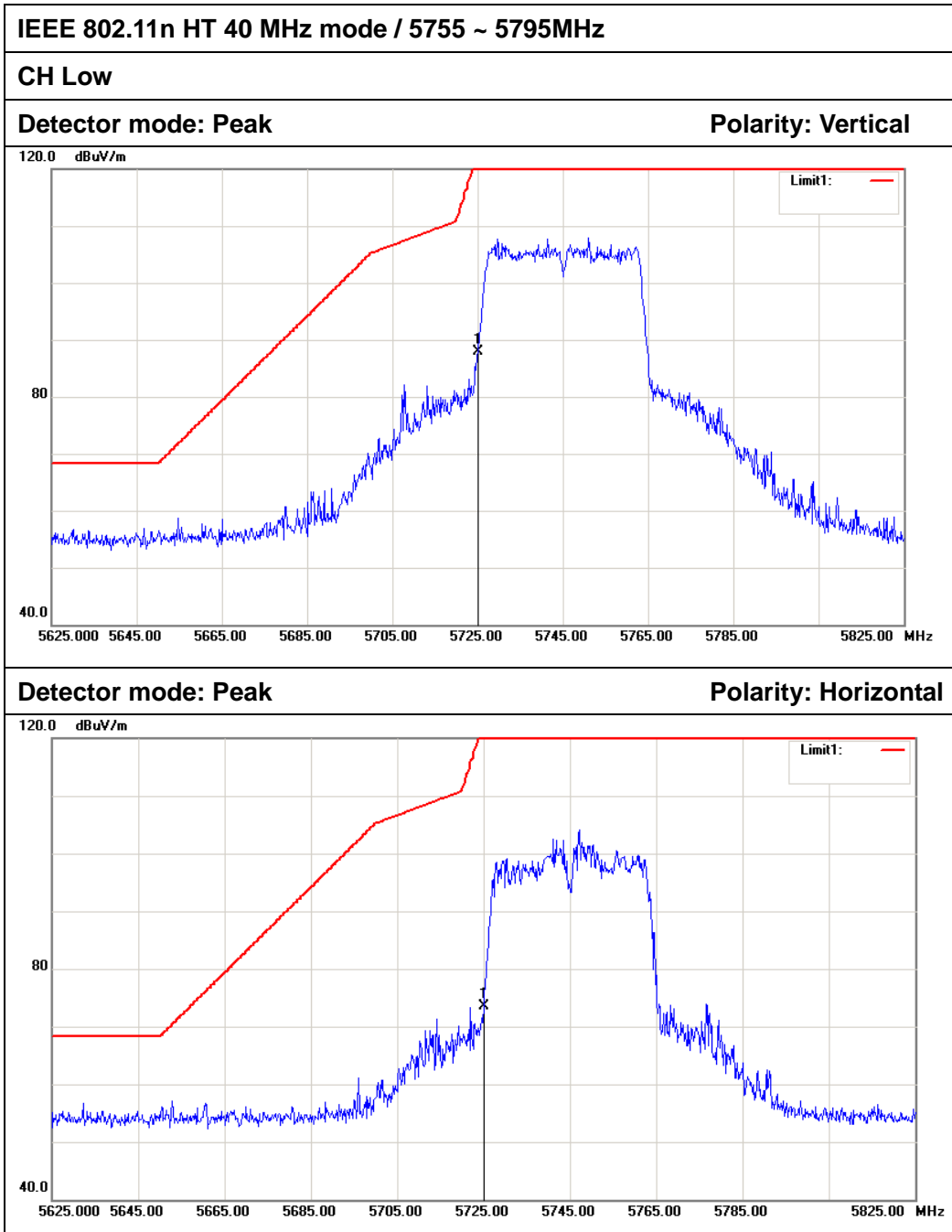

No.	Frequency (MHz)	Reading (dB)	Factor (dB/m)	Result (dB/m)	Limit (dB/m)	Margin (dB)	Remark	Antenna Polar
1	5725.000	82.00	5.96	87.96	122.20	-34.24	Peak	Vertical
2	5725.000	67.59	5.96	73.55	122.20	-48.65	Peak	Horizontal

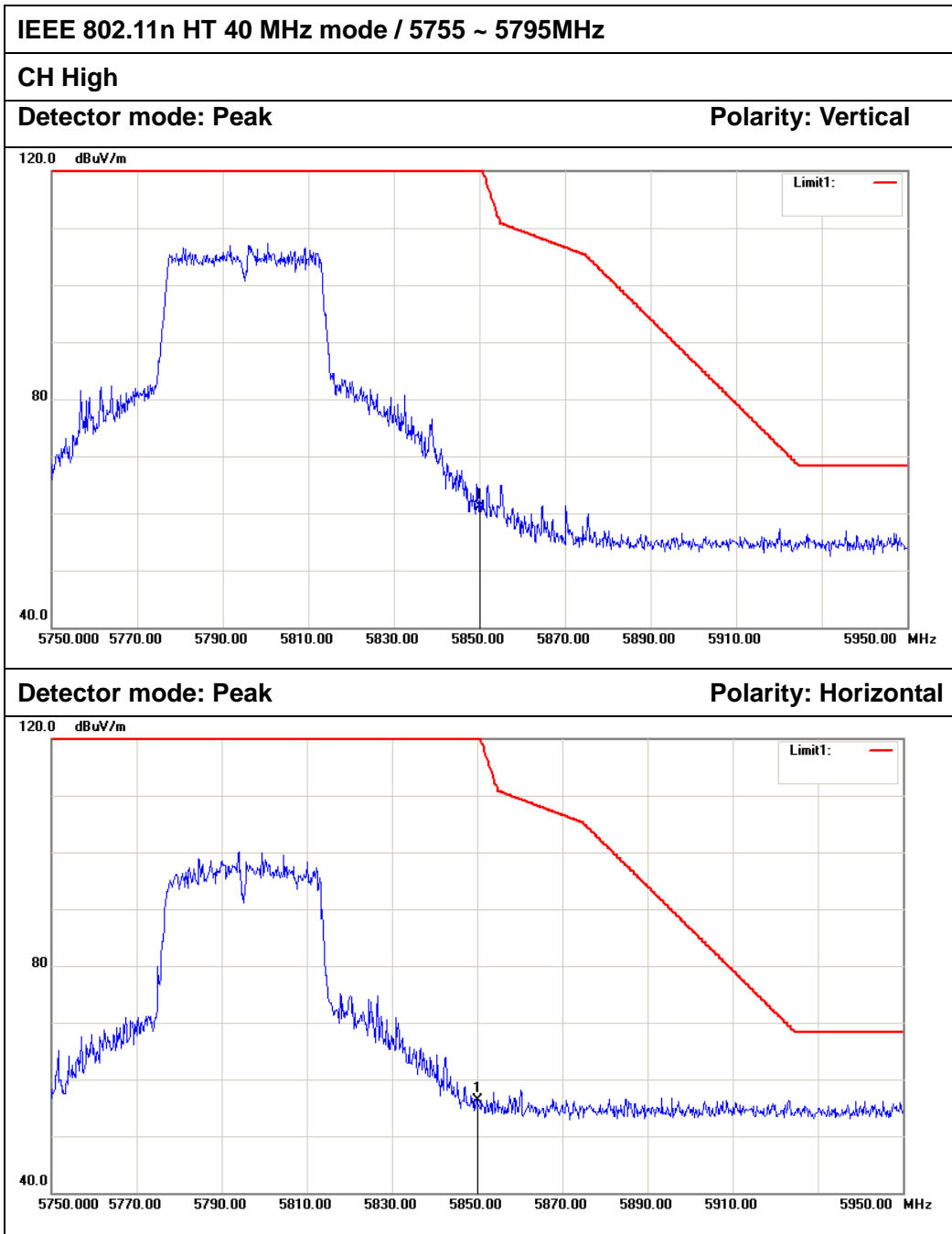

No.	Frequency (MHz)	Reading (dB)	Factor (dB/m)	Result (dB/m)	Limit (dB/m)	Margin (dB)	Remark	Antenna Polar
1	5850.000	55.06	6.02	61.08	122.20	-61.12	Peak	Vertical
2	5850.000	50.29	6.02	56.31	122.20	-65.89	Peak	Horizontal



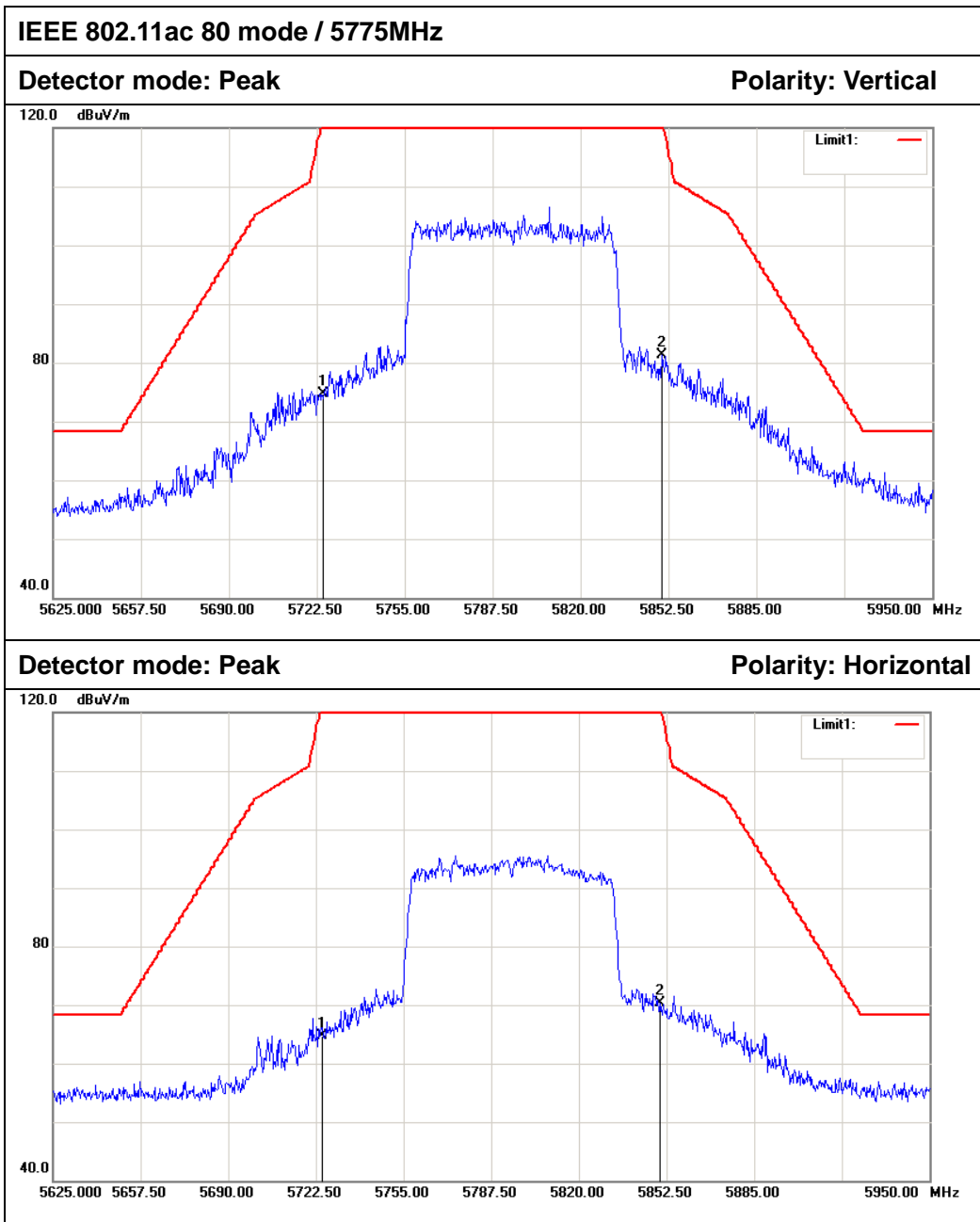

No.	Frequency (MHz)	Reading (dB)	Factor (dB/m)	Result (dB/m)	Limit (dB/m)	Margin (dB)	Remark	Antenna Polar
1	5725.000	68.79	5.96	74.75	122.20	-47.45	Peak	Vertical
2	5850.000	75.32	6.02	81.34	122.20	-40.86	Peak	Vertical
1	5725.000	58.79	5.96	64.75	122.20	-57.45	Peak	Horizontal
2	5850.000	64.27	6.02	70.29	122.20	-51.91	Peak	Horizontal



## 6.9 POWERLINE CONDUCTED EMISSIONS

### 6.9.1 LIMIT

According to §15.207(a), except as shown in paragraphs (b) and (c) of this section, for an intentional radiator that is designed to be connected to the public utility (AC) power line, the radio frequency voltage that is conducted back onto the AC power line on any frequency or frequencies within the band 150 kHz to 30 MHz shall not exceed the limits in the following table, as measured using a 50  $\mu$ H/50 ohms line impedance stabilization network (LISN). Compliance with the provisions of this paragraph shall be based on the measurement of the radio frequency voltage between each power line and ground at the power terminal. The lower limit applies at the boundary between the frequency ranges.

Frequency Range (MHz)	Limits (dB $\mu$ V)	
	Quasi-peak	Average
0.15 to 0.50	66 to 56*	56 to 46*
0.50 to 5	56	46
5 to 30	60	50

\* Decreases with the logarithm of the frequency.

### 6.9.2 TEST INSTRUMENTS

Conducted Emission Test Site					
Name of Equipment	Manufacturer	Model Number	Serial Number	Last Calibration	Due Calibration
EMI TEST RECEIVER	ROHDE&SCHWARZ	ESCI	100783	02/21/2017	02/20/2018
LISN(EUT)	ROHDE&SCHWARZ	ENV216	101543-WX	02/21/2017	02/20/2018
LISN	EMCO	3825/2	8901-1459	02/21/2017	02/20/2018
Temp. / Humidity Meter	VICTOR	HTC-1	N/A	02/21/2017	02/20/2018
Test S/W	FARAD	EZ-EMC/ CCS-3A1-CE			

**NOTE:** 1. The calibration interval of the above test instruments is 12 months and the calibrations are traceable to NML/ROC and NIST/USA.

2. N.C.R = No Calibration Request.



### 6.9.3 TEST CONFIGURATION

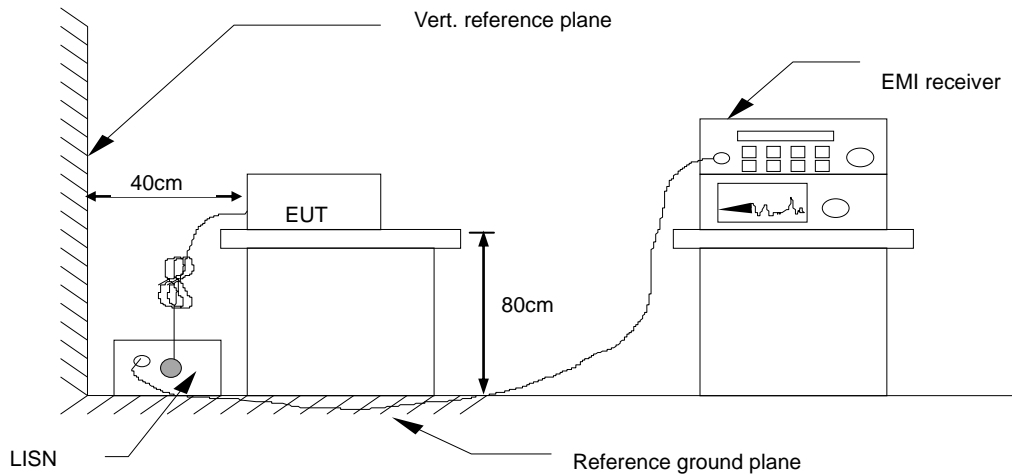

### 6.9.4 TEST PROCEDURE

1. The EUT was placed on a table, which is 0.8m above ground plane.
2. Maximum procedure was performed on the six highest emissions to ensure EUT compliance.
3. Repeat above procedures until all frequency measured were complete.

### 6.9.5 DATA SAMPLE

Frequency (MHz)	QuasiPeak Reading (dBuV)	Average Reading (dBuV)	Correction Factor (dB)	QuasiPeak Result (dBuV)	Average Result (dBuV)	QuasiPeak Limit (dBuV)	Average Limit (dBuV)	QuasiPeak Margin (dB)	Average Margin (dB)	Remark (Pass/Fail)
X.XXXX	32.69	25.65	11.52	44.21	37.17	65.78	55.79	-21.57	-18.62	Pass

Factor = Insertion loss of LISN + Cable Loss  
Result = Quasi-peak Reading/ Average Reading + Factor  
Limit = Limit stated in standard  
Margin = Result (dBuV) – Limit (dBuV)



6.9.6 TEST RESULTS

<b>Model No.</b>	MR1700	<b>RBW,VBW</b>	9 kHz
<b>Environmental Conditions</b>	22°C, 45% RH	<b>Test Mode</b>	Mode 1
<b>Tested by</b>	Fade Zhong	<b>Line</b>	L1
<b>Test Date</b>	July 19, 2017	<b>Test Voltage</b>	AC120V/60Hz

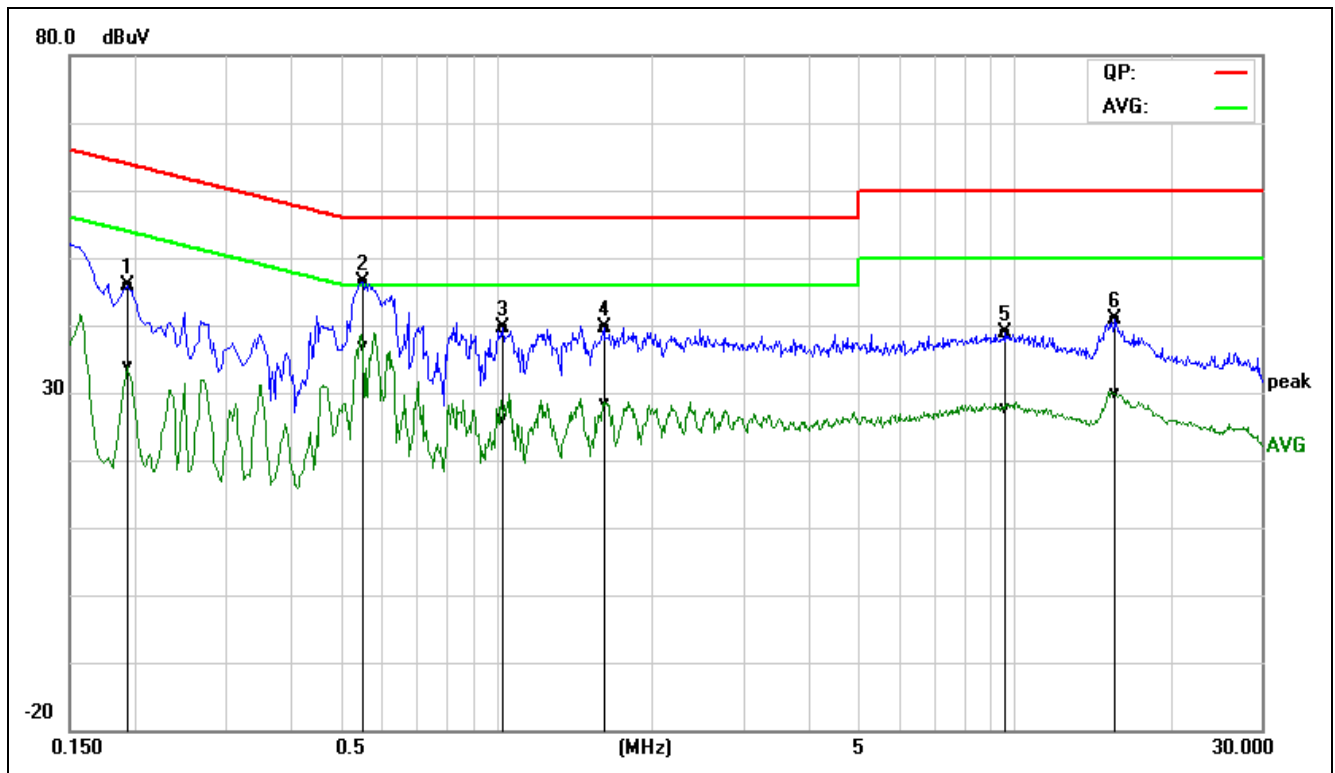

Frequency (MHz)	QuasiPeak Reading (dBuV)	Average Reading (dBuV)	Correction Factor (dB)	QuasiPeak Result (dBuV)	Average Result (dBuV)	QuasiPeak Limit (dBuV)	Average Limit (dBuV)	QuasiPeak Margin (dB)	Average Margin (dB)	Remark (Pass/Fail)	Line (L1/L2)
0.1940	26.19	14.15	19.64	45.83	33.79	63.86	53.86	-18.03	-20.07	Pass	L1
0.5540	26.85	17.21	19.55	46.40	36.76	56.00	46.00	-9.60	-9.24	Pass	L1
1.0300	20.14	6.53	19.55	39.69	26.08	56.00	46.00	-16.31	-19.92	Pass	L1
1.6180	20.01	8.85	19.65	39.66	28.50	56.00	46.00	-16.34	-17.50	Pass	L1
9.6140	18.86	7.50	20.11	38.97	27.61	60.00	50.00	-21.03	-22.39	Pass	L1
15.7020	20.70	9.74	20.06	40.76	29.80	60.00	50.00	-19.24	-20.20	Pass	L1

REMARKS: L1 = Line One (Live Line)



<b>Model No.</b>	MR1700	<b>RBW,VBW</b>	9 kHz
<b>Environmental Conditions</b>	22°C, 45% RH	<b>Test Mode</b>	Mode 1
<b>Tested by</b>	Fade Zhong	<b>Line</b>	L2
<b>Test Date</b>	July 19, 2017	<b>Test Voltage</b>	AC120V/60Hz

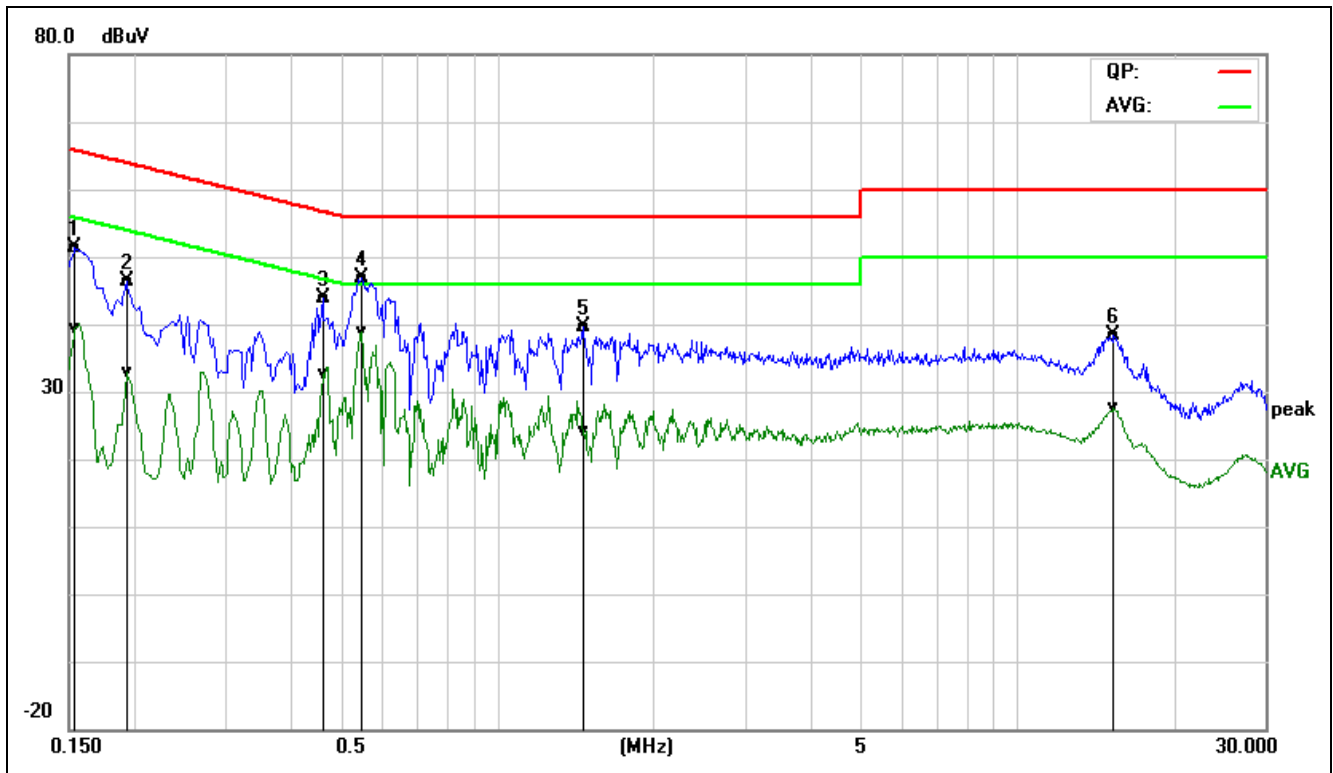

Frequency (MHz)	QuasiPeak Reading (dBuV)	Average Reading (dBuV)	Correction Factor (dB)	QuasiPeak Result (dBuV)	Average Result (dBuV)	QuasiPeak Limit (dBuV)	Average Limit (dBuV)	QuasiPeak Margin (dB)	Average Margin (dB)	Remark (Pass/Fail)	Line (L1/L2)
0.1539	31.79	19.97	19.52	51.31	39.49	65.78	55.79	-14.47	-16.30	Pass	L2
0.1940	26.75	13.27	19.54	46.29	32.81	63.86	53.86	-17.57	-21.05	Pass	L2
0.4620	24.46	13.16	19.53	43.99	32.69	56.66	46.66	-12.67	-13.97	Pass	L2
0.5500	27.29	19.32	19.55	46.84	38.87	56.00	46.00	-9.16	-7.13	Pass	L2
1.4660	19.91	4.39	19.63	39.54	24.02	56.00	46.00	-16.46	-21.98	Pass	L2
15.3300	18.26	7.48	20.03	38.29	27.51	60.00	50.00	-21.71	-22.49	Pass	L2

**REMARKS:** L2 = Line Two (Neutral Line)



<b>Model No.</b>	MR1700	<b>RBW,VBW</b>	9 kHz
<b>Environmental Conditions</b>	22°C, 45% RH	<b>Test Mode</b>	Mode 1
<b>Tested by</b>	Fade Zhong	<b>Line</b>	L1
<b>Test Date</b>	July 19, 2017	<b>Test Voltage</b>	AC240V/50Hz

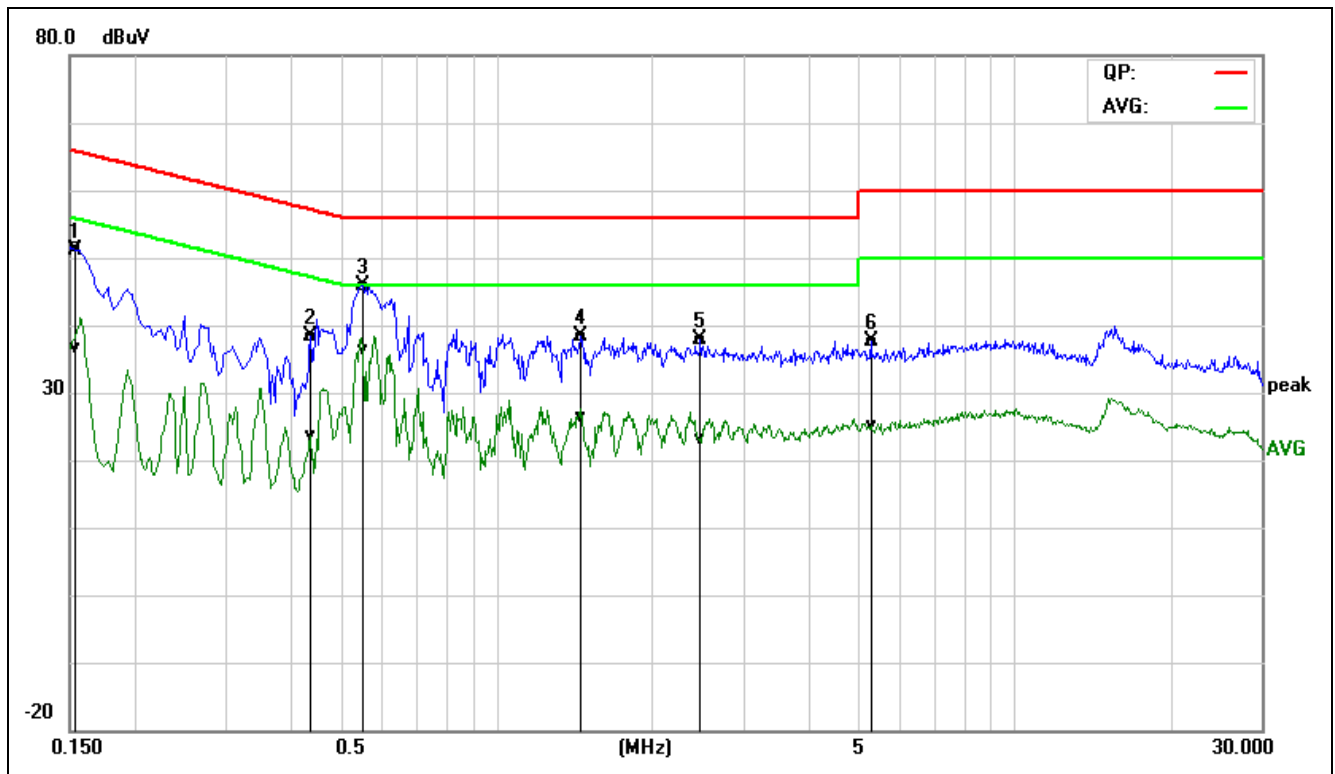

Frequency (MHz)	QuasiPeak Reading (dBuV)	Average Reading (dBuV)	Correction Factor (dB)	QuasiPeak Result (dBuV)	Average Result (dBuV)	QuasiPeak Limit (dBuV)	Average Limit (dBuV)	QuasiPeak Margin (dB)	Average Margin (dB)	Remark (Pass/Fail)	Line (L1/L2)
0.1556	31.97	17.06	19.62	51.59	36.68	65.69	55.70	-14.10	-19.02	Pass	L1
0.4380	18.85	4.01	19.55	38.40	23.56	57.10	47.10	-18.70	-23.54	Pass	L1
0.5540	26.35	16.71	19.55	45.90	36.26	56.00	46.00	-10.10	-9.74	Pass	L1
1.4620	18.72	6.70	19.63	38.35	26.33	56.00	46.00	-17.65	-19.67	Pass	L1
2.4860	18.08	3.39	19.72	37.80	23.11	56.00	46.00	-18.20	-22.89	Pass	L1
5.2860	17.88	5.30	19.74	37.62	25.04	60.00	50.00	-22.38	-24.96	Pass	L1

REMARKS: L1 = Line One (Live Line)



<b>Model No.</b>	MR1700	<b>RBW,VBW</b>	9 kHz
<b>Environmental Conditions</b>	22°C, 45% RH	<b>Test Mode</b>	Mode 1
<b>Tested by</b>	Fade Zhong	<b>Line</b>	L2
<b>Test Date</b>	July 19, 2017	<b>Test Voltage</b>	AC240V/50Hz

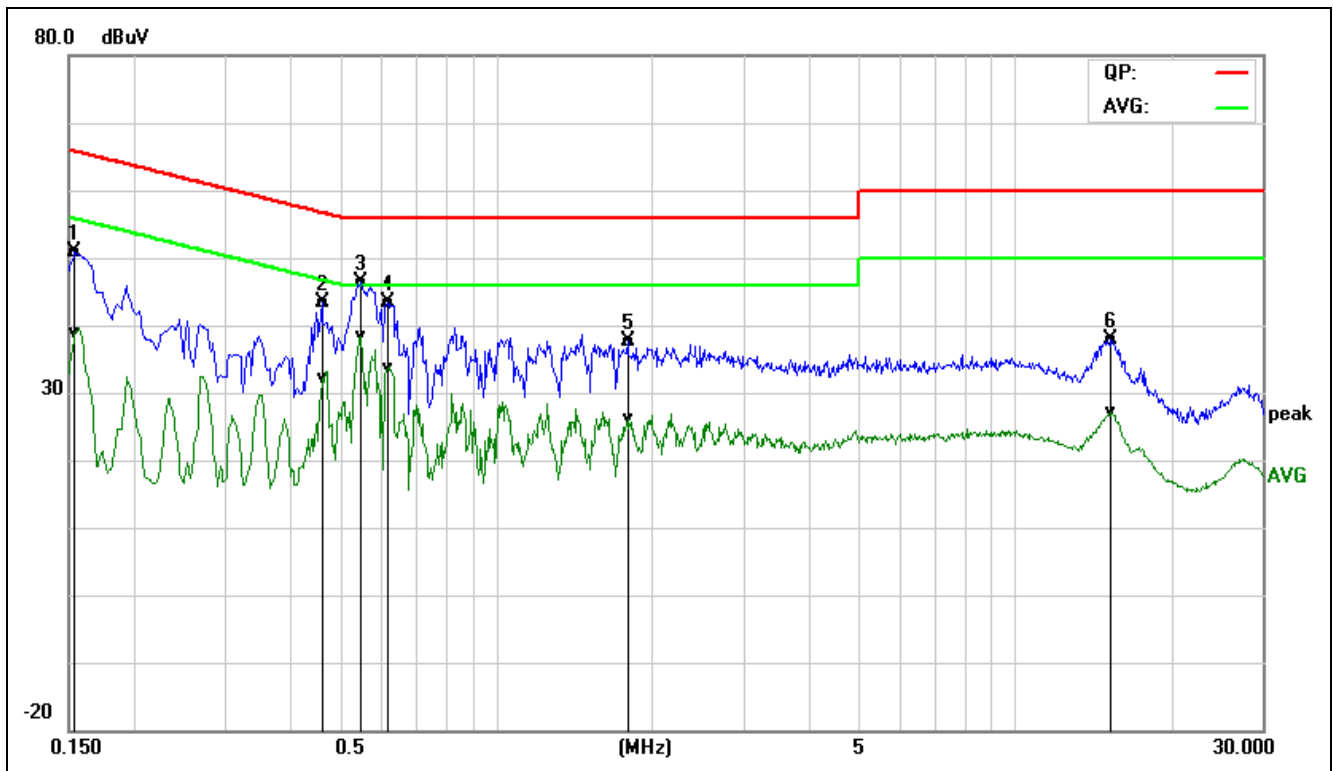

Frequency (MHz)	QuasiPeak Reading (dBuV)	Average Reading (dBuV)	Correction Factor (dB)	QuasiPeak Result (dBuV)	Average Result (dBuV)	QuasiPeak Limit (dBuV)	Average Limit (dBuV)	QuasiPeak Margin (dB)	Average Margin (dB)	Remark (Pass/Fail)	Line (L1/L2)
0.1539	31.29	19.47	19.52	50.81	38.99	65.78	55.79	-14.97	-16.80	Pass	L2
0.4620	23.96	12.66	19.53	43.49	32.19	56.66	46.66	-13.17	-14.47	Pass	L2
0.5500	26.79	18.82	19.55	46.34	38.37	56.00	46.00	-9.66	-7.63	Pass	L2
0.6180	23.86	14.05	19.58	43.44	33.63	56.00	46.00	-12.56	-12.37	Pass	L2
1.7940	17.96	6.40	19.69	37.65	26.09	56.00	46.00	-18.35	-19.91	Pass	L2
15.3300	17.76	6.98	20.03	37.79	27.01	60.00	50.00	-22.21	-22.99	Pass	L2

**REMARKS:** L2 = Line Two (Neutral Line)



## 6.10 FREQUENCY STABILITY

### 6.10.1 LIMIT

According to §15.407(g), manufacturers of U-NII devices are responsible for ensuring frequency stability such that an emission is maintained within the band of operation under all conditions of normal operation as specified in the operational description.

### 6.10.2 TEST INSTRUMENTS

Name of Equipment	Manufacturer	Model Number	Serial Number	Last Calibration	Due Calibration
Spectrum Analyzer	Agilent	N9010A	MY52221469	02/21/2017	02/20/2018
DC Power Supply	DAZHENG	PS-605D	20018978	N.C.R	N.C.R
AC POWER SOURCE	UMART	HPA1010	N/A	N.C.R	N.C.R
Power Meter	Anritsu	ML2495A	1204003	02/21/2017	02/20/2018
Power Sensor	Anritsu	MA2411B	1126150	02/21/2017	02/20/2018
Temperature Chamber	TERCHY	MHG-800N	E21104	11/18/2016	11/17/2017
Temp. / Humidity Meter	Anymetre	JR913	N/A	02/21/2017	02/20/2018

### 6.10.3 TEST CONFIGURATION

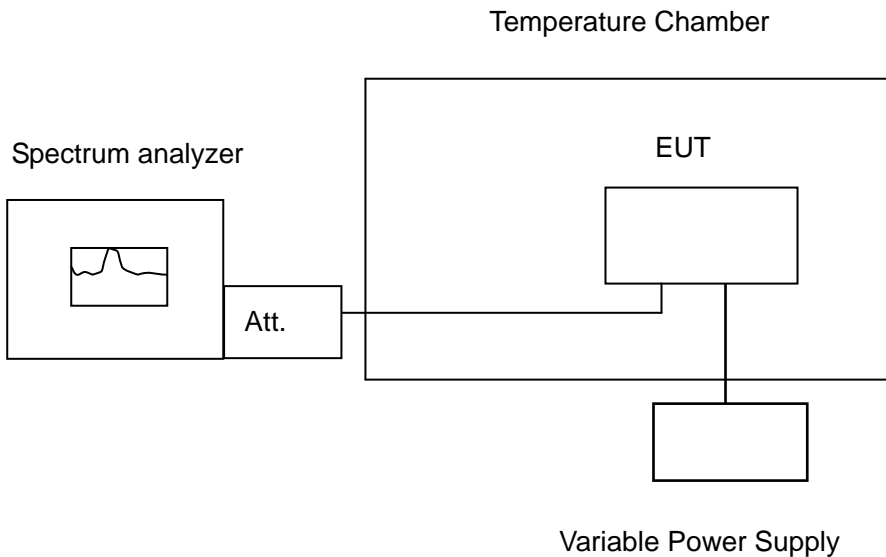

**Remark:** Measurement setup for testing on Antenna connector





#### 6.10.4 TEST PROCEDURE

The equipment under test was connected to an external AC or DC power supply and input rated voltage. RF output was connected to a frequency counter or spectrum analyzer via feed through attenuators. The EUT was placed inside the temperature chamber. Set the spectrum analyzer RBW low enough to obtain the desired frequency resolution and measure EUT 20°C operating frequency as reference frequency. Turn EUT off and set the chamber temperature to -20°C. After the temperature stabilized for approximately 30 minutes recorded the frequency. Repeat step measure with 10°C increased per stage until the highest temperature of +50°C reached.

#### 6.10.5 TEST RESULTS

*No non-compliance noted.*



Test Data  
Antenna 0

IEEE 802.11a MHz mode / 5180 ~ 5240MHz (Low)

Environment Temperature (°C)	Volage (V)	Measured Frequency (MHz)	limit Range	Test Result
50	120	5179.972777	5150-5250	PASS
40	120	5179.980852	5150-5250	PASS
30	120	5179.971728	5150-5250	PASS
20	120	5179.967820	5150-5250	PASS
10	120	5179.992482	5150-5250	PASS
0	120	5179.984352	5150-5250	PASS
-10	120	5179.972727	5150-5250	PASS
-20	120	5179.972050	5150-5250	PASS

Environment Temperature (°C)	Volage (V)	Measured Frequency (MHz)	limit Range	Test Result
20	108	5179.979072	5150-5250	PASS
	120	5179.967820	5150-5250	PASS
	132	5179.952163	5150-5250	PASS

IEEE 802.11a MHz mode / 5180 ~ 5240MHz (High)

Environment Temperature (°C)	Volage (V)	Measured Frequency (MHz)	limit Range	Test Result
50	120	5239.959596	5150-5250	PASS
40	120	5239.969736	5150-5250	PASS
30	120	5239.969438	5150-5250	PASS
20	120	5239.966570	5150-5250	PASS
10	120	5239.952738	5150-5250	PASS
0	120	5239.967049	5150-5250	PASS
-10	120	5239.950265	5150-5250	PASS
-20	120	5239.950242	5150-5250	PASS

Environment Temperature (°C)	Volage (V)	Measured Frequency (MHz)	limit Range	Test Result
20	108	5239.963149	5150-5250	PASS
	120	5239.966570	5150-5250	PASS
	132	5239.994845	5150-5250	PASS



IEEE 802.11a mode / 5745 ~ 5825MHz (Low)

Environment Temperature (°C)	Volage (V)	Measured Frequency (MHz)	limit Range	Test Result
50	120	5744.954411	5725-5850	PASS
40	120	5744.986742	5725-5850	PASS
30	120	5744.966378	5725-5850	PASS
20	120	5744.965754	5725-5850	PASS
10	120	5744.958344	5725-5850	PASS
0	120	5744.957193	5725-5850	PASS
-10	120	5744.954373	5725-5850	PASS
-20	120	5744.968340	5725-5850	PASS

Environment Temperature (°C)	Volage (V)	Measured Frequency (MHz)	limit Range	Test Result
20	108	5744.964734	5725-5850	PASS
	120	5744.965754	5725-5850	PASS
	132	5744.975903	5725-5850	PASS

IEEE 802.11a mode / 5745 ~ 5825MHz (High)

Environment Temperature (°C)	Volage (V)	Measured Frequency (MHz)	limit Range	Test Result
50	120	5824.979635	5725-5850	PASS
40	120	5824.971897	5725-5850	PASS
30	120	5824.979569	5725-5850	PASS
20	120	5824.965764	5725-5850	PASS
10	120	5824.976011	5725-5850	PASS
0	120	5824.962739	5725-5850	PASS
-10	120	5824.966787	5725-5850	PASS
-20	120	5824.964960	5725-5850	PASS

Environment Temperature (°C)	Volage (V)	Measured Frequency (MHz)	limit Range	Test Result
20	108	5824.980233	5725-5850	PASS
	120	5824.965764	5725-5850	PASS
	132	5824.960009	5725-5850	PASS



Antenna 1

IEEE 802.11a MHz mode / 5180 ~ 5240MHz (Low)

Environment Temperature (°C)	Volage (V)	Measured Frequency (MHz)	limit Range	Test Result
50	120	5179.976334	5150-5250	PASS
40	120	5179.970632	5150-5250	PASS
30	120	5179.950055	5150-5250	PASS
20	120	5179.966660	5150-5250	PASS
10	120	5179.998671	5150-5250	PASS
0	120	5179.975467	5150-5250	PASS
-10	120	5179.960536	5150-5250	PASS
-20	120	5179.982418	5150-5250	PASS

Environment Temperature (°C)	Volage (V)	Measured Frequency (MHz)	limit Range	Test Result
20	108	5179.995585	5150-5250	PASS
	120	5179.966660	5150-5250	PASS
	132	5179.955411	5150-5250	PASS

IEEE 802.11a MHz mode / 5180 ~ 5240MHz (High)

Environment Temperature (°C)	Volage (V)	Measured Frequency (MHz)	limit Range	Test Result
50	120	5239.980683	5150-5250	PASS
40	120	5239.993130	5150-5250	PASS
30	120	5239.976998	5150-5250	PASS
20	120	5239.966357	5150-5250	PASS
10	120	5239.962684	5150-5250	PASS
0	120	5239.990172	5150-5250	PASS
-10	120	5239.973570	5150-5250	PASS
-20	120	5239.951296	5150-5250	PASS

Environment Temperature (°C)	Volage (V)	Measured Frequency (MHz)	limit Range	Test Result
20	108	5239.983026	5150-5250	PASS
	120	5239.966357	5150-5250	PASS
	132	5239.986765	5150-5250	PASS



IEEE 802.11a mode / 5745 ~ 5825MHz (Low)

Environment Temperature (°C)	Volage (V)	Measured Frequency (MHz)	limit Range	Test Result
50	120	5744.966087	5725-5850	PASS
40	120	5744.960325	5725-5850	PASS
30	120	5744.950347	5725-5850	PASS
20	120	5744.966677	5725-5850	PASS
10	120	5744.969654	5725-5850	PASS
0	120	5744.968570	5725-5850	PASS
-10	120	5744.977618	5725-5850	PASS
-20	120	5744.960722	5725-5850	PASS

Environment Temperature (°C)	Volage (V)	Measured Frequency (MHz)	limit Range	Test Result
20	108	5744.986202	5725-5850	PASS
	120	5744.966677	5725-5850	PASS
	132	5744.968928	5725-5850	PASS

IEEE 802.11a mode / 5745 ~ 5825MHz (High)

Environment Temperature (°C)	Volage (V)	Measured Frequency (MHz)	limit Range	Test Result
50	120	5824.987142	5725-5850	PASS
40	120	5824.996379	5725-5850	PASS
30	120	5824.962598	5725-5850	PASS
20	120	5824.964256	5725-5850	PASS
10	120	5824.971257	5725-5850	PASS
0	120	5824.974087	5725-5850	PASS
-10	120	5824.993536	5725-5850	PASS
-20	120	5824.994421	5725-5850	PASS

Environment Temperature (°C)	Volage (V)	Measured Frequency (MHz)	limit Range	Test Result
20	108	5824.955400	5725-5850	PASS
	120	5824.964256	5725-5850	PASS
	132	5824.952674	5725-5850	PASS



Antenna 0

IEEE 802.11n HT 20 MHz mode / 5180 ~ 5240MHz (Low)

Environment Temperature (°C)	Volage (V)	Measured Frequency (MHz)	limit Range	Test Result
50	120	5179.977427	5150-5250	PASS
40	120	5179.992854	5150-5250	PASS
30	120	5179.993212	5150-5250	PASS
20	120	5179.966870	5150-5250	PASS
10	120	5179.960426	5150-5250	PASS
0	120	5179.985568	5150-5250	PASS
-10	120	5179.994280	5150-5250	PASS
-20	120	5179.960661	5150-5250	PASS

Environment Temperature (°C)	Volage (V)	Measured Frequency (MHz)	limit Range	Test Result
20	108	5179.989596	5150-5250	PASS
	120	5179.966870	5150-5250	PASS
	132	5179.960004	5150-5250	PASS

IEEE 802.11n HT 20 MHz mode / 5180 ~ 5240MHz (High)

Environment Temperature (°C)	Volage (V)	Measured Frequency (MHz)	limit Range	Test Result
50	120	5239.983881	5150-5250	PASS
40	120	5239.987509	5150-5250	PASS
30	120	5239.981514	5150-5250	PASS
20	120	5239.966742	5150-5250	PASS
10	120	5239.952272	5150-5250	PASS
0	120	5239.967799	5150-5250	PASS
-10	120	5239.952948	5150-5250	PASS
-20	120	5239.958401	5150-5250	PASS

Environment Temperature (°C)	Volage (V)	Measured Frequency (MHz)	limit Range	Test Result
20	108	5239.992957	5150-5250	PASS
	120	5239.966742	5150-5250	PASS
	132	5239.995241	5150-5250	PASS



IEEE 802.11n HT 20 MHz mode / 5745 ~ 5825MHz (Low)

Environment Temperature (°C)	Volage (V)	Measured Frequency (MHz)	limit Range	Test Result
50	120	5744.992260	5725-5850	PASS
40	120	5744.972347	5725-5850	PASS
30	120	5744.983555	5725-5850	PASS
20	120	5744.966664	5725-5850	PASS
10	120	5744.973282	5725-5850	PASS
0	120	5744.958116	5725-5850	PASS
-10	120	5744.967623	5725-5850	PASS
-20	120	5744.981619	5725-5850	PASS

Environment Temperature (°C)	Volage (V)	Measured Frequency (MHz)	limit Range	Test Result
20	108	5744.993816	5725-5850	PASS
	120	5744.966664	5725-5850	PASS
	132	5744.998610	5725-5850	PASS

IEEE 802.11n HT 20 MHz mode / 5745 ~ 5825MHz (High)

Environment Temperature (°C)	Volage (V)	Measured Frequency (MHz)	limit Range	Test Result
50	120	5824.989915	5725-5850	PASS
40	120	5824.976691	5725-5850	PASS
30	120	5824.962233	5725-5850	PASS
20	120	5824.966850	5725-5850	PASS
10	120	5824.997734	5725-5850	PASS
0	120	5824.997941	5725-5850	PASS
-10	120	5824.976977	5725-5850	PASS
-20	120	5824.977911	5725-5850	PASS

Environment Temperature (°C)	Volage (V)	Measured Frequency (MHz)	limit Range	Test Result
20	108	5824.980703	5725-5850	PASS
	120	5824.966850	5725-5850	PASS
	132	5824.964798	5725-5850	PASS



Antenna 1

IEEE 802.11n HT 20 MHz mode / 5180 ~ 5240MHz (Low)

Environment Temperature (°C)	Volage (V)	Measured Frequency (MHz)	limit Range	Test Result
50	120	5179.983002	5150-5250	PASS
40	120	5179.968848	5150-5250	PASS
30	120	5179.981299	5150-5250	PASS
20	120	5179.965854	5150-5250	PASS
10	120	5179.996026	5150-5250	PASS
0	120	5179.969828	5150-5250	PASS
-10	120	5179.969779	5150-5250	PASS
-20	120	5179.990558	5150-5250	PASS

Environment Temperature (°C)	Volage (V)	Measured Frequency (MHz)	limit Range	Test Result
20	108	5179.960714	5150-5250	PASS
	120	5179.965854	5150-5250	PASS
	132	5179.992370	5150-5250	PASS

IEEE 802.11n HT 20 MHz mode / 5180 ~ 5240MHz (High)

Environment Temperature (°C)	Volage (V)	Measured Frequency (MHz)	limit Range	Test Result
50	120	5239.965082	5150-5250	PASS
40	120	5239.997268	5150-5250	PASS
30	120	5239.960530	5150-5250	PASS
20	120	5239.965664	5150-5250	PASS
10	120	5239.997690	5150-5250	PASS
0	120	5239.965410	5150-5250	PASS
-10	120	5239.988145	5150-5250	PASS
-20	120	5239.971701	5150-5250	PASS

Environment Temperature (°C)	Volage (V)	Measured Frequency (MHz)	limit Range	Test Result
20	108	5239.988585	5150-5250	PASS
	120	5239.965664	5150-5250	PASS
	132	5239.961954	5150-5250	PASS





**IEEE 802.11n HT 20 MHz mode / 5745 ~ 5825MHz (Low)**

Environment Temperature (°C)	Volage (V)	Measured Frequency (MHz)	limit Range	Test Result
50	120	5744.950429	5725-5850	PASS
40	120	5744.950314	5725-5850	PASS
30	120	5744.974153	5725-5850	PASS
20	120	5744.965664	5725-5850	PASS
10	120	5744.975459	5725-5850	PASS
0	120	5744.957215	5725-5850	PASS
-10	120	5744.990982	5725-5850	PASS
-20	120	5744.982992	5725-5850	PASS

Environment Temperature (°C)	Volage (V)	Measured Frequency (MHz)	limit Range	Test Result
20	108	5744.958608	5725-5850	PASS
	120	5744.965664	5725-5850	PASS
	132	5744.957711	5725-5850	PASS

**IEEE 802.11n HT 20 MHz mode / 5745 ~ 5825MHz (High)**

Environment Temperature (°C)	Volage (V)	Measured Frequency (MHz)	limit Range	Test Result
50	120	5824.976746	5725-5850	PASS
40	120	5824.988759	5725-5850	PASS
30	120	5824.992091	5725-5850	PASS
20	120	5824.965870	5725-5850	PASS
10	120	5824.959392	5725-5850	PASS
0	120	5824.958980	5725-5850	PASS
-10	120	5824.971906	5725-5850	PASS
-20	120	5824.970330	5725-5850	PASS

Environment Temperature (°C)	Volage (V)	Measured Frequency (MHz)	limit Range	Test Result
20	108	5824.950291	5725-5850	PASS
	120	5824.965870	5725-5850	PASS
	132	5824.962724	5725-5850	PASS



Antenna 0

IEEE 802.11n HT 40 MHz mode / 5190 ~ 5230MHz (Low)

Environment Temperature (°C)	Volage (V)	Measured Frequency (MHz)	limit Range	Test Result
50	120	5189.987976	5150-5250	PASS
40	120	5189.951177	5150-5250	PASS
30	120	5189.977681	5150-5250	PASS
20	120	5189.965542	5150-5250	PASS
10	120	5189.985261	5150-5250	PASS
0	120	5189.979857	5150-5250	PASS
-10	120	5189.985916	5150-5250	PASS
-20	120	5189.969606	5150-5250	PASS

Environment Temperature (°C)	Volage (V)	Measured Frequency (MHz)	limit Range	Test Result
20	108	5189.989385	5150-5250	PASS
	120	5189.965542	5150-5250	PASS
	132	5189.969451	5150-5250	PASS

IEEE 802.11n HT 40 MHz mode / 5190 ~ 5230MHz (High)

Environment Temperature (°C)	Volage (V)	Measured Frequency (MHz)	limit Range	Test Result
50	120	5229.966864	5150-5250	PASS
40	120	5229.995450	5150-5250	PASS
30	120	5229.976219	5150-5250	PASS
20	120	5229.966650	5150-5250	PASS
10	120	5229.978622	5150-5250	PASS
0	120	5229.963936	5150-5250	PASS
-10	120	5229.994631	5150-5250	PASS
-20	120	5229.953206	5150-5250	PASS

Environment Temperature (°C)	Volage (V)	Measured Frequency (MHz)	limit Range	Test Result
20	108	5229.998468	5150-5250	PASS
	120	5229.966650	5150-5250	PASS
	132	5229.990542	5150-5250	PASS



**IEEE 802.11n HT 40 MHz mode / 5755 ~ 5795MHz (Low)**

Environment Temperature (°C)	Volage (V)	Measured Frequency (MHz)	limit Range	Test Result
50	120	5754.957978	5725-5850	PASS
40	120	5754.956997	5725-5850	PASS
30	120	5754.987324	5725-5850	PASS
20	120	5754.966674	5725-5850	PASS
10	120	5754.978387	5725-5850	PASS
0	120	5754.956584	5725-5850	PASS
-10	120	5754.986605	5725-5850	PASS
-20	120	5754.955123	5725-5850	PASS

Environment Temperature (°C)	Volage (V)	Measured Frequency (MHz)	limit Range	Test Result
20	108	5754.986025	5725-5850	PASS
	120	5754.966674	5725-5850	PASS
	132	5754.973538	5725-5850	PASS

**IEEE 802.11n HT 40 MHz mode / 5755 ~ 5795MHz (High)**

Environment Temperature (°C)	Volage (V)	Measured Frequency (MHz)	limit Range	Test Result
50	120	5794.993619	5725-5850	PASS
40	120	5794.954829	5725-5850	PASS
30	120	5794.990959	5725-5850	PASS
20	120	5794.966820	5725-5850	PASS
10	120	5794.987011	5725-5850	PASS
0	120	5794.953160	5725-5850	PASS
-10	120	5794.950356	5725-5850	PASS
-20	120	5794.999629	5725-5850	PASS

Environment Temperature (°C)	Volage (V)	Measured Frequency (MHz)	limit Range	Test Result
20	108	5794.974410	5725-5850	PASS
	120	5794.966820	5725-5850	PASS
	132	5794.949023	5725-5850	PASS



Antenna 1

IEEE 802.11n HT 40 MHz mode / 5190 ~ 5230MHz (Low)

Environment Temperature (°C)	Volage (V)	Measured Frequency (MHz)	limit Range	Test Result
50	120	5189.954550	5150-5250	PASS
40	120	5189.982617	5150-5250	PASS
30	120	5189.957334	5150-5250	PASS
20	120	5189.965687	5150-5250	PASS
10	120	5189.994038	5150-5250	PASS
0	120	5189.952984	5150-5250	PASS
-10	120	5189.975233	5150-5250	PASS
-20	120	5189.997718	5150-5250	PASS

Environment Temperature (°C)	Volage (V)	Measured Frequency (MHz)	limit Range	Test Result
20	108	5189.961711	5150-5250	PASS
	120	5189.965687	5150-5250	PASS
	132	5189.974090	5150-5250	PASS

IEEE 802.11n HT 40 MHz mode / 5190 ~ 5230MHz (High)

Environment Temperature (°C)	Volage (V)	Measured Frequency (MHz)	limit Range	Test Result
50	120	5229.961229	5150-5250	PASS
40	120	5229.953200	5150-5250	PASS
30	120	5229.976496	5150-5250	PASS
20	120	5229.966840	5150-5250	PASS
10	120	5229.988011	5150-5250	PASS
0	120	5229.990609	5150-5250	PASS
-10	120	5229.962635	5150-5250	PASS
-20	120	5229.973315	5150-5250	PASS

Environment Temperature (°C)	Volage (V)	Measured Frequency (MHz)	limit Range	Test Result
20	108	5229.962222	5150-5250	PASS
	120	5229.966840	5150-5250	PASS
	132	5229.958673	5150-5250	PASS



**IEEE 802.11n HT 40 MHz mode / 5755 ~ 5795MHz (Low)**

Environment Temperature (°C)	Volage (V)	Measured Frequency (MHz)	limit Range	Test Result
50	120	5754.998155	5725-5850	PASS
40	120	5754.971991	5725-5850	PASS
30	120	5754.993087	5725-5850	PASS
20	120	5754.965684	5725-5850	PASS
10	120	5754.959503	5725-5850	PASS
0	120	5754.967028	5725-5850	PASS
-10	120	5754.970221	5725-5850	PASS
-20	120	5754.995196	5725-5850	PASS

Environment Temperature (°C)	Volage (V)	Measured Frequency (MHz)	limit Range	Test Result
20	108	5754.974946	5725-5850	PASS
	120	5754.965684	5725-5850	PASS
	132	5754.954814	5725-5850	PASS

**IEEE 802.11n HT 40 MHz mode / 5755 ~ 5795MHz (High)**

Environment Temperature (°C)	Volage (V)	Measured Frequency (MHz)	limit Range	Test Result
50	120	5794.962971	5725-5850	PASS
40	120	5794.968591	5725-5850	PASS
30	120	5794.994592	5725-5850	PASS
20	120	5794.966874	5725-5850	PASS
10	120	5794.966586	5725-5850	PASS
0	120	5794.994347	5725-5850	PASS
-10	120	5794.988982	5725-5850	PASS
-20	120	5794.974012	5725-5850	PASS

Environment Temperature (°C)	Volage (V)	Measured Frequency (MHz)	limit Range	Test Result
20	108	5794.989097	5725-5850	PASS
	120	5794.966874	5725-5850	PASS
	132	5794.980522	5725-5850	PASS



Antenna 0

IEEE 802.11ac 80 mode / 5210MHz

Environment Temperature (°C)	Volage (V)	Measured Frequency (MHz)	limit Range	Test Result
50	120	5209.995334	5150-5250	PASS
40	120	5209.999099	5150-5250	PASS
30	120	5209.965408	5150-5250	PASS
20	120	5209.966540	5150-5250	PASS
10	120	5209.953421	5150-5250	PASS
0	120	5209.996722	5150-5250	PASS
-10	120	5209.967580	5150-5250	PASS
-20	120	5209.970005	5150-5250	PASS

Environment Temperature (°C)	Volage (V)	Measured Frequency (MHz)	limit Range	Test Result
20	108	5209.964476	5150-5250	PASS
	120	5209.966540	5150-5250	PASS
	132	5209.989479	5150-5250	PASS

IEEE 802.11ac 80 mode / 5775MHz

Environment Temperature (°C)	Volage (V)	Measured Frequency (MHz)	limit Range	Test Result
50	120	5774.966439	5725-5850	PASS
40	120	5774.983410	5725-5850	PASS
30	120	5774.985989	5725-5850	PASS
20	120	5774.965740	5725-5850	PASS
10	120	5774.966041	5725-5850	PASS
0	120	5774.975954	5725-5850	PASS
-10	120	5774.970906	5725-5850	PASS
-20	120	5774.976543	5725-5850	PASS

Environment Temperature (°C)	Volage (V)	Measured Frequency (MHz)	limit Range	Test Result
20	108	5774.970293	5725-5850	PASS
	120	5774.965740	5725-5850	PASS
	132	5774.950666	5725-5850	PASS



Antenna 1

IEEE 802.11ac 80 mode / 5210MHz

Environment Temperature (°C)	Volage (V)	Measured Frequency (MHz)	limit Range	Test Result
50	120	5209.963328	5150-5250	PASS
40	120	5209.998668	5150-5250	PASS
30	120	5209.991231	5150-5250	PASS
20	120	5209.965884	5150-5250	PASS
10	120	5209.967700	5150-5250	PASS
0	120	5209.972548	5150-5250	PASS
-10	120	5209.956768	5150-5250	PASS
-20	120	5209.963822	5150-5250	PASS

Environment Temperature (°C)	Volage (V)	Measured Frequency (MHz)	limit Range	Test Result
20	108	5209.957879	5150-5250	PASS
	120	5209.965884	5150-5250	PASS
	132	5209.956176	5150-5250	PASS

IEEE 802.11ac 80 mode / 5775MHz

Environment Temperature (°C)	Volage (V)	Measured Frequency (MHz)	limit Range	Test Result
50	120	5774.990962	5725-5850	PASS
40	120	5774.984386	5725-5850	PASS
30	120	5774.961205	5725-5850	PASS
20	120	5774.967854	5725-5850	PASS
10	120	5774.977831	5725-5850	PASS
0	120	5774.984455	5725-5850	PASS
-10	120	5774.981742	5725-5850	PASS
-20	120	5774.998016	5725-5850	PASS

Environment Temperature (°C)	Volage (V)	Measured Frequency (MHz)	limit Range	Test Result
20	108	5774.987755	5725-5850	PASS
	120	5774.967854	5725-5850	PASS
	132	5774.960053	5725-5850	PASS