

FCC Test Report

Report No.: RF160824C02

FCC ID: 2AF5PMG7540

Test Model: MG7540

Series Model: MG7540XY (where X can be A, B, C, D or blank, and Y can be A, B, C, D or blank.)

Received Date: Aug. 24, 2016

Test Date: Sep. 19 ~ Oct. 04, 2016

Issued Date: Oct. 07, 2016

Applicant: MTRLC LLC

Address: PO Box 121147 Boston, MA 02112-1147, United States.

Issued By: Bureau Veritas Consumer Products Services (H.K.) Ltd., Taoyuan Branch

Lab Address: No. 47-2, 14th Ling, Chia Pau Vil., Lin Kou Dist., New Taipei City, Taiwan, R.O.C.

Test Location: No. 19, Hwa Ya 2nd Rd., Wen Hwa Vil., Kwei Shan Dist., Taoyuan City 33383, TAIWAN (R.O.C.)



This report is for your exclusive use. Any copying or replication of this report to or for any other person or entity, or use of our name or trademark, is permitted only with our prior written permission. This report sets forth our findings solely with respect to the test samples identified herein. The results set forth in this report are not indicative or representative of the quality or characteristics of the lot from which a test sample was taken or any similar or identical product unless specifically and expressly noted. Our report includes all of the tests requested by you and the results thereof based upon the information that you provided to us. You have 60 days from date of issuance of this report to notify us of any material error or omission caused by our negligence, provided, however, that such notice shall be in writing and shall specifically address the issue you wish to raise. A failure to raise such issue within the prescribed time shall constitute your unqualified acceptance of the completeness of this report, the tests conducted and the correctness of the report contents. Unless specific mention, the uncertainty of measurement has been explicitly taken into account to declare the compliance or non-compliance to the specification. The report must not be used by the client to claim product certification, approval, or endorsement by TAF or any government agencies.

Table of Contents

Release Control Record	4
1 Certificate of Conformity	5
2 Summary of Test Results	6
2.1 Measurement Uncertainty.....	6
2.2 Modification Record.....	6
3 General Information	7
3.1 General Description of EUT.....	7
3.2 Description of Test Modes.....	9
3.2.1 Test Mode Applicability and Tested Channel Detail.....	10
3.3 Duty Cycle of Test Signal.....	12
3.4 Description of Support Units.....	13
3.4.1 Configuration of System under Test.....	13
3.5 General Description of Applied Standards.....	13
4 Test Types and Results	14
4.1 Radiated Emission and Bandedge Measurement.....	14
4.1.1 Limits of Radiated Emission and Bandedge Measurement.....	14
4.1.2 Test Instruments.....	15
4.1.3 Test Procedures.....	16
4.1.4 Deviation from Test Standard.....	16
4.1.5 Test Set Up.....	17
4.1.6 EUT Operating Conditions.....	18
4.1.7 Test Results.....	19
4.2 Conducted Emission Measurement.....	40
4.2.1 Limits of Conducted Emission Measurement.....	40
4.2.2 Test Instruments.....	40
4.2.3 Test Procedures.....	41
4.2.4 Deviation from Test Standard.....	41
4.2.5 Test Setup.....	41
4.2.6 EUT Operating Conditions.....	41
4.2.7 Test Results.....	42
4.3 Transmit Power Measurement.....	44
4.3.1 Limits of Transmit Power Measurement.....	44
4.3.2 Test Setup.....	44
4.3.3 Test Instruments.....	45
4.3.4 Test Procedure.....	45
4.3.5 Deviation from Test Standard.....	45
4.3.6 EUT Operating Conditions.....	45
4.3.7 Test Result.....	46
4.4 Occupied Bandwidth Measurement.....	51
4.4.1 Test Setup.....	51
4.4.2 Test Instruments.....	51
4.4.3 Test Procedure.....	51
4.4.4 Test Result.....	52
4.5 Peak Power Spectral Density Measurement.....	55
4.5.1 Limits of Peak Power Spectral Density Measurement.....	55
4.5.2 Test Setup.....	55
4.5.3 Test Instruments.....	55
4.5.4 Test Procedures.....	55
4.5.5 Deviation from Test Standard.....	55
4.5.6 EUT Operating Conditions.....	55
4.5.7 Test Results.....	56
4.6 Frequency Stability.....	59
4.6.1 Limits of Frequency Stability Measurement.....	59

4.6.2 Test Setup.....	59
4.6.3 Test Instruments	59
4.6.4 Test Procedure	59
4.6.5 Deviation from Test Standard	59
4.6.6 EUT Operating Condition	59
4.6.7 Test Results	60
5 Pictures of Test Arrangements.....	61
Appendix – Information on the Testing Laboratories	62

Release Control Record

Issue No.	Description	Date Issued
RF160824C02	Original release	Oct. 07, 2016

1 Certificate of Conformity

Product: 16x4 DOCSIS 3.0 Cable Modem plus AC1600 Router

Brand: Motorola

Test Model: MG7540

Series Model: MG7540XY (where X can be A, B, C, D or blank, and Y can be A, B, C, D or blank.)

Sample Status: Engineering Sample

Applicant: MTRLC LLC

Test Date: Sep. 19 ~ Oct. 04, 2016

Standards: 47 CFR FCC Part 15, Subpart E (Section 15.407)
ANSI C63.10:2013

The above equipment has been tested by **Bureau Veritas Consumer Products Services (H.K.) Ltd., Taoyuan Branch**, and found compliance with the requirement of the above standards. The test record, data evaluation & Equipment Under Test (EUT) configurations represented herein are true and accurate accounts of the measurements of the sample's EMC characteristics under the conditions specified in this report.

Prepared by : Celine Chou , **Date:** Oct. 07, 2016
Celine Chou / Specialist

Approved by : Ken Liu , **Date:** Oct. 07, 2016
Ken Liu / Senior Manager

2 Summary of Test Results

47 CFR FCC Part 15, Subpart E (Section 15.407)			
FCC Clause	Test Item	Result	Remarks
15.407(b)(6)	AC Power Conducted Emissions	Pass	Meet the requirement of limit. Minimum passing margin is -0.35dB at 0.78733MHz.
15.407(b) (1/2/3/4(i/ii)/6)	Radiated Emissions & Band Edge Measurement	Pass	Meet the requirement of limit. Minimum passing margin is -1.0dB at 5350.00MHz, 5378.00MHz and 5470.00MHz.
15.407(a)(1/2/3)	Max Average Transmit Power	Pass	Meet the requirement of limit.
---	Occupied Bandwidth Measurement	-	Reference only.
15.407(a)(1/2/3)	Peak Power Spectral Density	Pass	Meet the requirement of limit.
15.407(g)	Frequency Stability	Pass	Meet the requirement of limit.
15.203	Antenna Requirement	Pass	Antenna connector is RSMA not a standard connector.

2.1 Measurement Uncertainty

Where relevant, the following measurement uncertainty levels have been estimated for tests performed on the EUT as specified in CISPR 16-4-2:

Measurement	Frequency	Expanded Uncertainty (k=2) (\pm)
Conducted Emissions at mains ports	150kHz ~ 30MHz	2.44 dB
Radiated Emissions up to 1 GHz	30MHz ~ 200MHz	3.63 dB
	200MHz ~ 1000MHz	3.64 dB
Radiated Emissions above 1 GHz	1GHz ~ 18GHz	2.29 dB
	18GHz ~ 40GHz	2.29 dB

2.2 Modification Record

There were no modifications required for compliance.

3 General Information

3.1 General Description of EUT

Product	16x4 DOCSIS 3.0 Cable Modem plus AC1600 Router
Brand	Motorola
Test Model	MG7540
Series Model	MG7540XY (where X can be A, B, C, D or blank, and Y can be A, B, C, D or blank.)
Model Difference	The optional suffixes X and Y are to be used for identical hardware models that differ for marketing/sales purposes only.
Status of EUT	Engineering Sample
Power Supply Rating	12Vdc (adapter)
Modulation Type	256QAM, 64QAM, 16QAM, QPSK, BPSK for OFDM
Modulation Technology	OFDM
Transfer Rate	802.11a: 54.0/ 48.0/ 36.0/ 24.0/ 18.0/ 12.0/ 9.0/ 6.0Mbps 802.11n: up to 150Mbps 802.11ac: up to 433Mbps
Operating Frequency	5260 ~ 5320MHz, 5500 ~ 5700MHz
Number of Channel	5260 ~ 5320MHz: 802.11a, 802.11n (HT20), 802.11ac (VHT20): 4 802.11n (HT40), 802.11ac (VHT40): 2 802.11ac (VHT80): 1 5500 ~ 5700MHz: 802.11a, 802.11n (HT20), 802.11ac (VHT20): 11 802.11n (HT40), 802.11ac (VHT40): 5 802.11ac (VHT80): 2
Output Power	5260 ~ 5320MHz: 244.974mW 5500 ~ 5700MHz: 249.877mW
Antenna Type	Wire antenna with 2.8dBi gain
Antenna Connector	RSMA
Accessory Device	Adapter
Data Cable Supplied	1.48m non-shielded RJ45 cable w/o core

Note:

1. This report is prepared for FCC class II permissive change. This report is adding 5.26GHz to 5.32GHz and 5.50GHz to 5.70GHz by software.

2. The EUT incorporates a MIMO function. Physically, the EUT provides 3 completed transmitters and 3 receivers.

Modulation Mode	TX Function
802.11a	3TX
802.11n (HT20)	3TX
802.11n (HT40)	3TX
802.11ac (VHT20)	3TX
802.11ac (VHT40)	3TX
802.11ac (VHT80)	3TX

* The modulation and bandwidth are similar for 802.11n mode for 20MHz/40MHz and 802.11ac mode for 20MHz/40MHz, therefore investigated worst case to representative mode in test report. (Final test mode refer section 3.2.1)

3. The EUT uses following adapter.

Adapter	
Brand	Gongjin
Model	S24B72-120A200-C4
Input Power	100-240Vac, 50/60Hz Max, 0.8A
Output Power	12Vdc, 2A
Power Line	1.5m cable without core attached on adapter

3.2 Description of Test Modes

For 5260 ~ 5320MHz

4 channels are provided for 802.11a, 802.11n (HT20), 802.11ac (VHT20):

Channel	Frequency	Channel	Frequency
52	5260 MHz	60	5300 MHz
56	5280 MHz	64	5320 MHz

2 channels are provided for 802.11n (HT40), 802.11ac (VHT40):

Channel	Frequency	Channel	Frequency
54	5270 MHz	62	5310 MHz

1 channel is provided for 802.11ac (VHT80):

Channel	Frequency
58	5290 MHz

For 5500 ~ 5700MHz

11 channels are provided for 802.11a, 802.11n (HT20), 802.11ac (VHT20):

Channel	Frequency	Channel	Frequency
100	5500 MHz	124	5620 MHz
104	5520 MHz	128	5640 MHz
108	5540 MHz	132	5660 MHz
112	5560 MHz	136	5680 MHz
116	5580 MHz	140	5700 MHz
120	5600 MHz		

5 channels are provided for 802.11n (HT40), 802.11ac (VHT40):

Channel	Frequency	Channel	Frequency
102	5510 MHz	126	5630 MHz
110	5550 MHz	134	5670 MHz
118	5590 MHz		

2 channels are provided for 802.11ac (VHT80):

Channel	Frequency	Channel	Frequency
106	5530 MHz	122	5610 MHz

3.2.1 Test Mode Applicability and Tested Channel Detail

EUT CONFIGURE MODE	APPLICABLE TO				DESCRIPTION
	RE≥1G	RE<1G	PLC	APCM	
-	√	√	√	√	-

Where **RE≥1G**: Radiated Emission above 1GHz & Bandedge Measurement
RE<1G: Radiated Emission below 1GHz
PLC: Power Line Conducted Emission
APCM: Antenna Port Conducted Measurement

Note: The EUT had been pre-tested on the positioned of each 3 axis. The worst case was found when positioned on **Z-plane**.

Radiated Emission Test (Above 1GHz):

- Pre-Scan has been conducted to determine the worst-case mode from all possible combinations between available modulations, data rates and antenna ports (if EUT with antenna diversity architecture).
- Following channel(s) was (were) selected for the final test as listed below.

EUT CONFIGURE MODE	MODE	FREQ. BAND (MHz)	AVAILABLE CHANNEL	TESTED CHANNEL	MODULATION TECHNOLOGY	MODULATION TYPE	DATA RATE (Mbps)
-	802.11a	5260-5320	52 to 64	52, 60, 64	OFDM	BPSK	6.0
-	802.11n (HT20)		52 to 64	52, 60, 64	OFDM	BPSK	6.5
-	802.11n (HT40)		54 to 62	54, 62	OFDM	BPSK	13.5
-	802.11ac (VHT80)		58	58	OFDM	BPSK	29.5
-	802.11a	5500-5700	100 to 140	100, 116, 140	OFDM	BPSK	6.0
-	802.11n (HT20)		100 to 140	100, 116, 140	OFDM	BPSK	6.5
-	802.11n (HT40)		102 to 134	102, 110, 134	OFDM	BPSK	13.5
-	802.11ac (VHT80)		106 to 122	106, 122	OFDM	BPSK	29.5

Radiated Emission Test (Below 1GHz):

- Pre-Scan has been conducted to determine the worst-case mode from all possible combinations between available modulations, data rates and antenna ports (if EUT with antenna diversity architecture).
- Following channel(s) was (were) selected for the final test as listed below.

EUT CONFIGURE MODE	MODE	FREQ. BAND (MHz)	AVAILABLE CHANNEL	TESTED CHANNEL	MODULATION TECHNOLOGY	MODULATION TYPE	DATA RATE (Mbps)
-	802.11a	5260-5320	52 to 64	52	OFDM	BPSK	6.0
-	802.11a	5500-5700	100 to 140		OFDM	BPSK	6.0

Power Line Conducted Emission Test:

- Pre-Scan has been conducted to determine the worst-case mode from all possible combinations between available modulations, data rates and antenna ports (if EUT with antenna diversity architecture).
- Following channel(s) was (were) selected for the final test as listed below.

EUT CONFIGURE MODE	MODE	FREQ. BAND (MHz)	AVAILABLE CHANNEL	TESTED CHANNEL	MODULATION TECHNOLOGY	MODULATION TYPE	DATA RATE (Mbps)
-	802.11a	5260-5320	52 to 64	52	OFDM	BPSK	6.0
-	802.11a	5500-5700	100 to 140		OFDM	BPSK	6.0

Antenna Port Conducted Measurement:

- This item includes all test value of each mode, but only includes spectrum plot of worst value of each mode.
- Pre-Scan has been conducted to determine the worst-case mode from all possible combinations between available modulations, data rates and antenna ports (if EUT with antenna diversity architecture).
- Following channel(s) was (were) selected for the final test as listed below.

EUT CONFIGURE MODE	MODE	FREQ. BAND (MHz)	AVAILABLE CHANNEL	TESTED CHANNEL	MODULATION TECHNOLOGY	MODULATION TYPE	DATA RATE (Mbps)
-	802.11a	5260-5320	52 to 64	52, 60, 64	OFDM	BPSK	6.0
-	802.11n (HT20)		52 to 64	52, 60, 64	OFDM	BPSK	6.5
-	802.11n (HT40)		54 to 62	54, 62	OFDM	BPSK	13.5
-	802.11ac (VHT80)		58	58	OFDM	BPSK	29.5
-	802.11a	5500-5700	100 to 140	100, 116, 140	OFDM	BPSK	6.0
-	802.11n (HT20)		100 to 140	100, 116, 140	OFDM	BPSK	6.5
-	802.11n (HT40)		102 to 134	102, 110, 134	OFDM	BPSK	13.5
-	802.11ac (VHT80)		106 to 122	106, 122	OFDM	BPSK	29.5

Test Condition:

APPLICABLE TO	ENVIRONMENTAL CONDITIONS	INPUT POWER	TESTED BY
RE≥1G	20deg. C, 69%RH	120Vac, 60Hz	Bayu Chen
RE<1G	20deg. C, 69%RH	120Vac, 60Hz	Bayu Chen
PLC	20deg. C, 69%RH	120Vac, 60Hz	Chris Lin
APCM	24deg. C, 64%RH	120Vac, 60Hz	Antony Lee

3.3 Duty Cycle of Test Signal

Duty cycle of test signal is < 98 %, duty factor is required.

802.11a: Duty cycle = $2.062/2.170 = 0.950$, Duty factor = $10 * \log(1/0.950) = 0.22$

802.11n (HT20): Duty cycle = $1.917/2.020 = 0.949$, Duty factor = $10 * \log(1/0.949) = 0.23$

802.11n (HT40): Duty cycle = $0.935/1.043 = 0.896$, Duty factor = $10 * \log(1/0.896) = 0.47$

802.11ac (VHT80): Duty cycle = $0.445/0.497 = 0.895$, Duty factor = $10 * \log(1/0.895) = 0.48$

802.11a

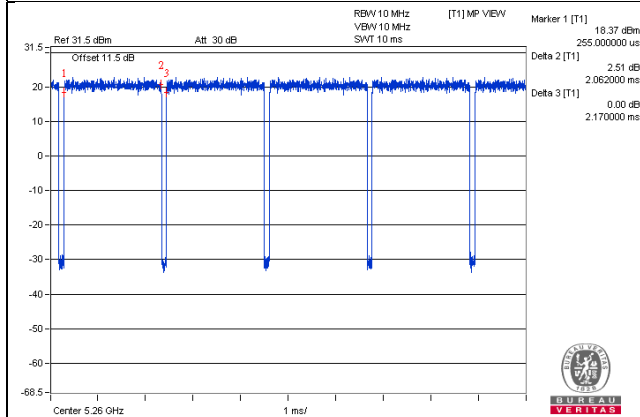

802.11n (HT20)

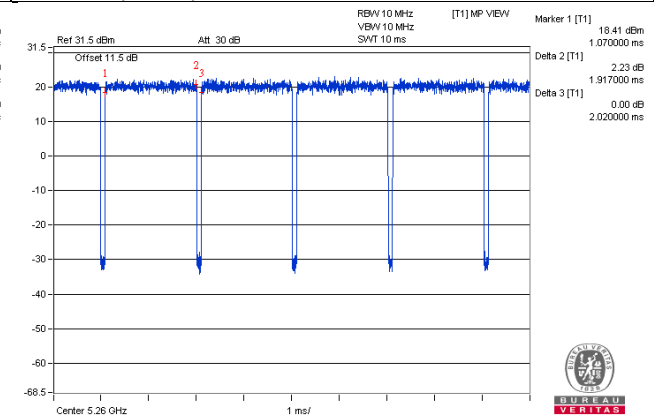

802.11n (HT40)

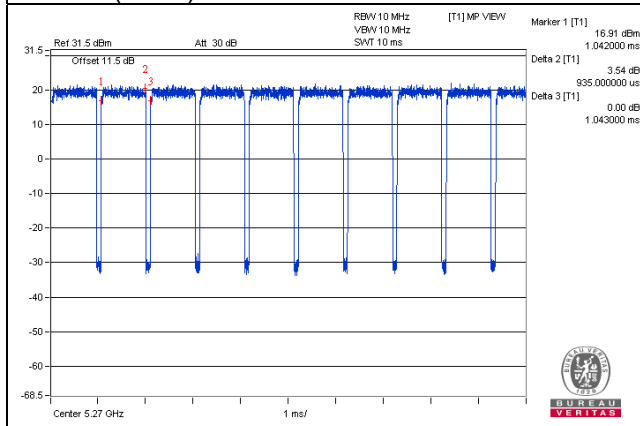

802.11ac (VHT80)

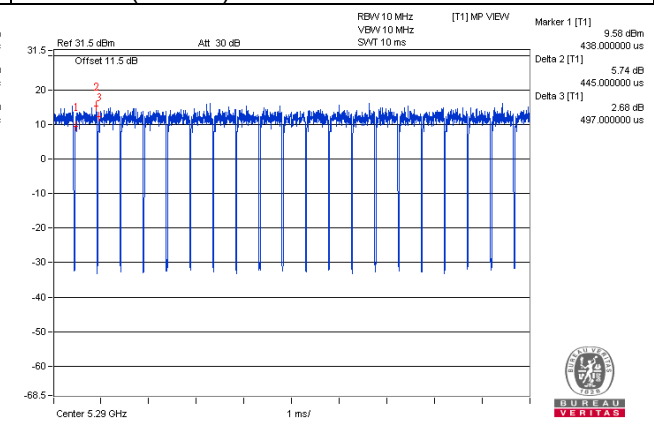

3.4 Description of Support Units

The EUT has been tested as an independent unit together with other necessary accessories or support units. The following support units or accessories were used to form a representative test configuration during the tests.

ID	Product	Brand	Model No.	Serial No.	FCC ID	Remarks
A.	Load	NA	NA	NA	NA	-
B.	Notebook	DELL	E5420	BPQ7MQ1	FCC DoC Approved	-

Note:

1. All power cords of the above support units are non-shielded (1.8m).
2. Item B acted as communication partner to transfer data.

ID	Descriptions	Qty.	Length (m)	Shielding (Yes/No)	Cores (Qty.)	Remarks
1.	Cat.5e cable	3	1.8	N	0	-
2.	Coaxial cable	1	1.8	Y	0	-
3.	Cat.5e cable	1	10	N	0	-

3.4.1 Configuration of System under Test

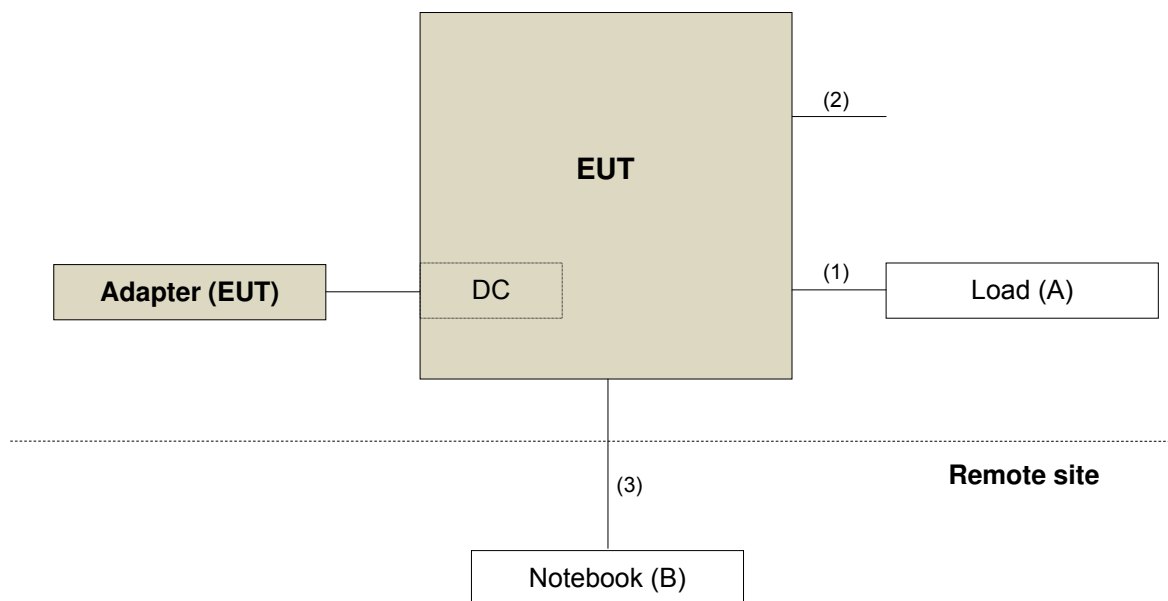

3.5 General Description of Applied Standards

The EUT is a RF Product. According to the specifications of the manufacturer, it must comply with the requirements of the following standards:

FCC Part 15, Subpart E (15.407)

KDB 789033 D02 General UNII Test Procedures New Rules v01r03

KDB 662911 D01 Multiple Transmitter Output v02r01

ANSI C63.10-2013

All test items have been performed and recorded as per the above standards.

Note: The EUT is also considered as a kind of computer peripheral, because the connection to computer is necessary for typical use. It has been verified to comply with the requirements of FCC Part 15, Subpart B, Class B (DoC). The test report has been issued separately.

4 Test Types and Results

4.1 Radiated Emission and Bandedge Measurement

4.1.1 Limits of Radiated Emission and Bandedge Measurement

Radiated emissions which fall in the restricted bands must comply with the radiated emission limits specified as below table.

Frequencies (MHz)	Field Strength (microvolts/meter)	Measurement Distance (meters)
0.009 ~ 0.490	2400/F(kHz)	300
0.490 ~ 1.705	24000/F(kHz)	30
1.705 ~ 30.0	30	30
30 ~ 88	100	3
88 ~ 216	150	3
216 ~ 960	200	3
Above 960	500	3

Note:

1. The lower limit shall apply at the transition frequencies.
2. Emission level (dBuV/m) = 20 log Emission level (uV/m).
3. For frequencies above 1000MHz, the field strength limits are based on average detector, however, the peak field strength of any emission shall not exceed the maximum permitted average limits, specified above by more than 20dB under any condition of modulation.

Limits of unwanted emission out of the restricted bands

Applicable To		Limit	
789033 D02 General UNII Test Procedure New Rules v01r03		Field Strength at 3m	
		PK:74 (dBuV/m)	AV:54 (dBuV/m)
Frequency Band	Applicable To	EIRP Limit	Equivalent Field Strength at 3m
5150~5250 MHz	15.407(b)(1)	PK:-27 (dBm/MHz)	PK:68.2(dBuV/m)
5250~5350 MHz	15.407(b)(2)		
5470~5725 MHz	15.407(b)(3)		
5725~5850 MHz	<input type="checkbox"/> 15.407(b)(4)(i)	PK:-27 (dBm/MHz) ^{*1} PK:10 (dBm/MHz) ^{*2} PK:15.6 (dBm/MHz) ^{*3} PK:27 (dBm/MHz) ^{*4}	PK: 68.2(dBuV/m) ^{*1} PK:105.2 (dBuV/m) ^{*2} PK: 110.8(dBuV/m) ^{*3} PK:122.2 (dBuV/m) ^{*4}
	<input type="checkbox"/> 15.407(b)(4)(ii)	Emission limits in section 15.247(d)	
^{*1} beyond 75 MHz or more above of the band edge.		^{*2} below the band edge increasing linearly to 10 dBm/MHz at 25 MHz above.	
^{*3} below the band edge increasing linearly to a level of 15.6 dBm/MHz at 5 MHz above.		^{*4} from 5 MHz above or below the band edge increasing linearly to a level of 27 dBm/MHz at the band edge.	

Note: The following formula is used to convert the equipment isotropic radiated power (eirp) to field strength:

$$E = \frac{1000000\sqrt{30P}}{3} \mu\text{V/m, where P is the eirp (Watts).}$$

4.1.2 Test Instruments

Description & Manufacturer	Model No.	Serial No.	Date Of Calibration	Due Date Of Calibration
Test Receiver ROHDE & SCHWARZ	ESCS30	100289	Dec. 23, 2015	Dec. 22, 2016
Spectrum Analyzer ROHDE & SCHWARZ	FSP40	100269	Apr. 19, 2016	Apr. 18, 2017
BILOG Antenna SCHWARZBECK	VULB9168	9168-148	Jan. 18, 2016	Jan. 17, 2017
HORN Antenna SCHWARZBECK	BBHA 9120 D	9120D-1169	Jan. 08, 2016	Jan. 07, 2017
HORN Antenna SCHWARZBECK	BBHA 9170	BBHA9170241	Jan. 18, 2016	Jan. 17, 2017
Loop Antenna	EM-6879	269	Aug. 11, 2016	Aug. 10, 2017
Preamplifier Agilent	8449B	3008A01911	Aug. 09, 2016	Aug. 08, 2017
Preamplifier Agilent	8447D	2944A10638	Aug. 09, 2016	Aug. 08, 2017
RF signal cable HUBER+SUHNER	SUCOFLEX 104	CABLE-CH9-02(309222 +248780)	Aug. 09, 2016	Aug. 08, 2017
RF signal cable HUBER+SUHNER	SUCOFLEX 104	CABLE-CH9-03(274092)	Aug. 09, 2016	Aug. 08, 2017
RF signal cable Woken	8D-FB	Cable-CH9-01	Aug. 09, 2016	Aug. 08, 2017
Software BV ADT	ADT_Radiated_ V7.6.15.9.4	NA	NA	NA
Antenna Tower EMCO	2070/2080	512.835.4684	NA	NA
Turn Table EMCO	2087-2.03	NA	NA	NA
Antenna Tower & Turn BV ADT	AT100	AT93021705	NA	NA
Turn Table BV ADT	TT100	TT93021705	NA	NA
Turn Table Controller BV ADT	SC100	SC93021705	NA	NA
26GHz ~ 40GHz Amplifier	EM26400	815221	Oct. 18, 2015	Oct. 17, 2016
High Speed Peak Power Meter	ML2495A	0824011	Jul. 09, 2016	Jul. 08, 2017
Power Sensor	MA2411B	0738171	Aug. 11, 2016	Aug. 10, 2017

- Note:
1. The calibration interval of the above test instruments is 12 months and the calibrations are traceable to NML/ROC and NIST/USA.
 2. The test was performed in HwaYa Chamber 9.
 3. The horn antenna and preamplifier (model: 8449B) are used only for the measurement of emission frequency above 1GHz if tested.
 4. The FCC Site Registration No. is 215374.
 5. The IC Site Registration No. is IC 7450F-9.

4.1.3 Test Procedures

For Radiated emission below 30MHz

- a. The EUT was placed on the top of a rotating table 0.8 meters above the ground at a 3 meter chamber room. The table was rotated 360 degrees to determine the position of the highest radiation.
- b. The EUT was set 3 meters away from the interference-receiving antenna, which was mounted on the top of a variable-height antenna tower.
- c. Both X and Y axes of the antenna are set to make the measurement.
- d. For each suspected emission, the EUT was arranged to its worst case and the rotatable table was turned from 0 degrees to 360 degrees to find the maximum reading.
- e. The test-receiver system was set to Quasi-Peak Detect Function and Specified Bandwidth with Maximum Hold Mode.

Note:

1. The resolution bandwidth and video bandwidth of test receiver/spectrum analyzer is 9kHz at frequency below 30MHz.

For Radiated emission above 30MHz

- a. The EUT was placed on the top of a rotating table 0.8 meters (for 30MHz ~ 1GHz) / 1.5 meters (for above 1GHz) above the ground at 3 meter chamber room for test. The table was rotated 360 degrees to determine the position of the highest radiation.
- b. The EUT was set 3 meters away from the interference-receiving antenna, which was mounted on the top of a variable-height antenna tower.
- c. The height of antenna is varied from one meter to four meters above the ground to determine the maximum value of the field strength. Both horizontal and vertical polarizations of the antenna are set to make the measurement.
- d. For each suspected emission, the EUT was arranged to its worst case and then the antenna was tuned to heights from 1 meter to 4 meters and the rotatable table was turned from 0 degrees to 360 degrees to find the maximum reading.
- e. The test-receiver system was set to quasi-peak detect function and specified bandwidth with maximum hold mode when the test frequency is below 1 GHz.
- f. The test-receiver system was set to peak and average detect function and specified bandwidth with maximum hold mode when the test frequency is above 1 GHz. If the peak reading value also meets average limit, measurement with the average detector is unnecessary.

Note:

1. The resolution bandwidth and video bandwidth of test receiver/spectrum analyzer is 120kHz for Quasi-peak detection (QP) at frequency below 1GHz.
2. The resolution bandwidth of test receiver/spectrum analyzer is 1 MHz and the video bandwidth is 3 MHz for Peak detection (PK) at frequency above 1GHz.
3. The resolution bandwidth of test receiver/spectrum analyzer is 1MHz and the video bandwidth is $\geq 1/T$ (Duty cycle < 98%) or 10Hz (Duty cycle $\geq 98\%$) for Average detection (AV) at frequency above 1GHz.
4. All modes of operation were investigated and the worst-case emissions are reported.

4.1.4 Deviation from Test Standard

No deviation.

4.1.5 Test Set Up

For Radiated emission below 30MHz

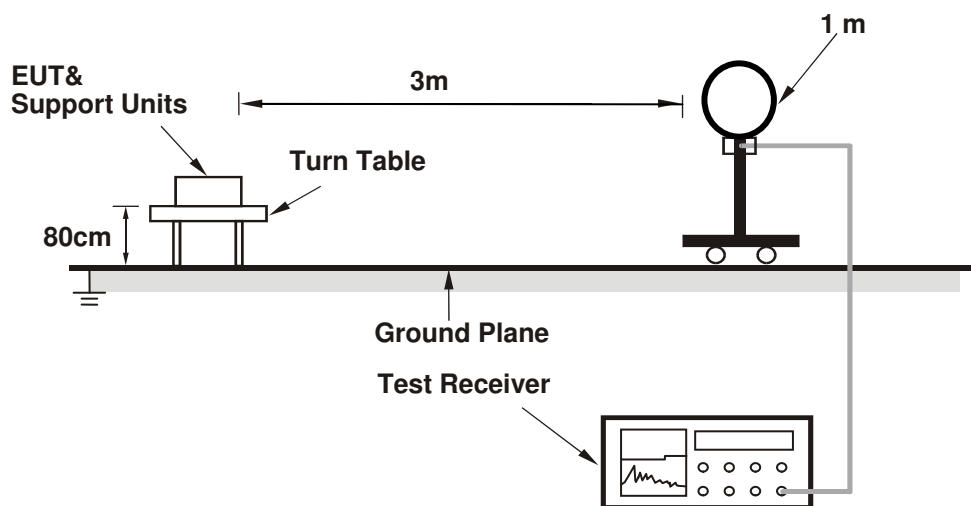

For Radiated emission 30MHz to 1GHz

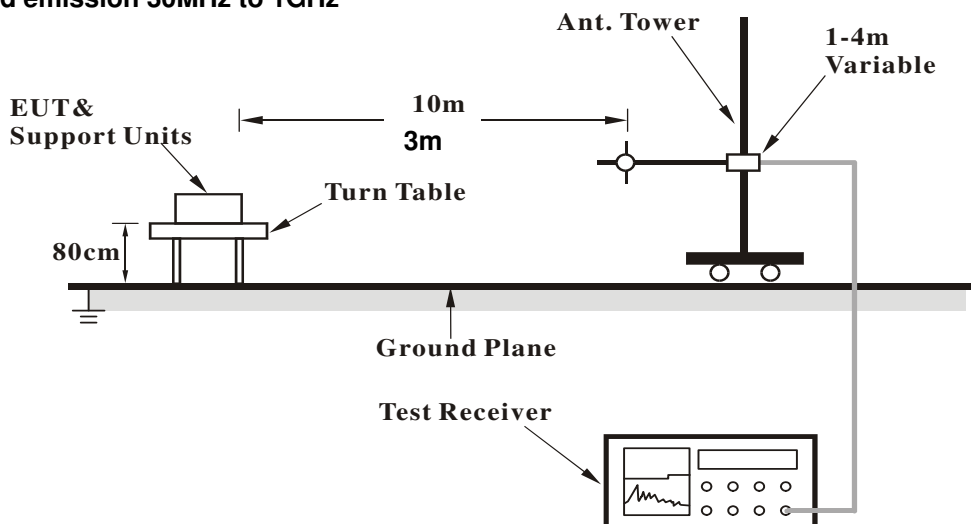

For Radiated emission above 1GHz

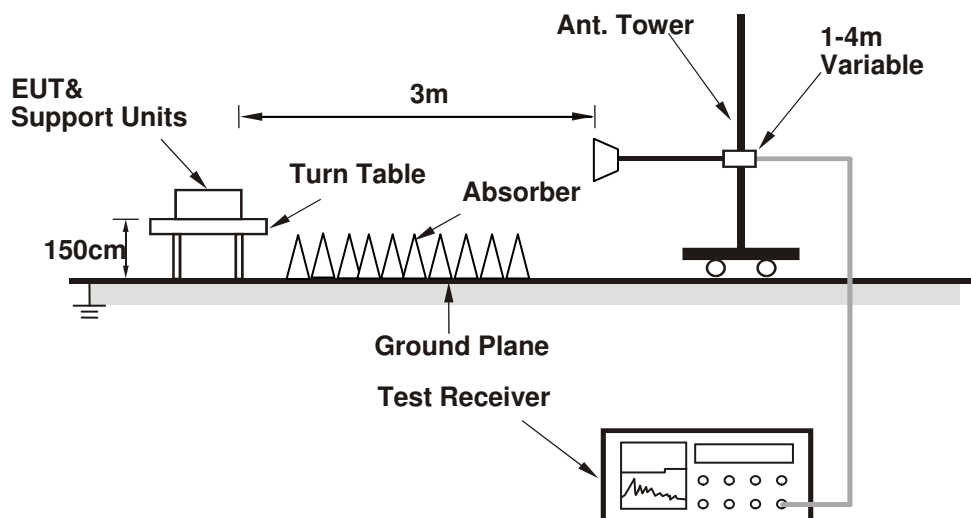

For the actual test configuration, please refer to the attached file (Test Setup Photo).

4.1.6 EUT Operating Conditions

- a. Placed the EUT on the testing table.
- b. Prepared notebooks to act as communication partner and placed it outside of testing area.
- c. The communication partner connected with EUT via a RJ45 cable and ran a test program (provided by manufacturer) to enable EUT under transmission condition continuously at specific channel frequency.
- d. The communication partner sent data to EUT by command "PING".
- e. The necessary accessories enable the system in full functions.

4.1.7 Test Results

Above 1GHz Worst-case Data:

802.11a

CHANNEL	TX Channel 52	DETECTOR FUNCTION	Peak (PK) Average (AV)
FREQUENCY RANGE	1GHz ~ 40GHz		

ANTENNA POLARITY & TEST DISTANCE: HORIZONTAL AT 3 M								
NO.	FREQ. (MHz)	EMISSION LEVEL (dBuV/m)	LIMIT (dBuV/m)	MARGIN (dB)	ANTENNA HEIGHT (m)	TABLE ANGLE (Degree)	RAW VALUE (dBuV)	CORRECTION FACTOR (dB/m)
1	5000.00	62.2 PK	74.0	-11.8	1.47 H	56	57.9	4.3
2	5000.00	51.3 AV	54.0	-2.7	1.47 H	56	47.0	4.3
3	5103.00	62.3 PK	74.0	-11.7	1.82 H	284	57.9	4.4
4	5103.00	48.4 AV	54.0	-5.6	1.82 H	284	44.0	4.4
5	*5260.00	114.6 PK			1.44 H	54	71.7	42.9
6	*5260.00	104.9 AV			1.44 H	54	62.0	42.9
7	5418.00	65.1 PK	74.0	-8.9	2.51 H	53	60.3	4.8
8	5418.00	52.2 AV	54.0	-1.8	2.51 H	53	47.4	4.8
9	#7013.00	57.7 PK	74.0	-16.3	1.38 H	47	47.7	10.0
10	#7013.00	48.0 AV	54.0	-6.0	1.38 H	47	38.0	10.0
11	#10520.00	62.2 PK	74.0	-11.8	1.86 H	143	46.2	16.0
12	#10520.00	48.2 AV	54.0	-5.8	1.86 H	143	32.2	16.0
ANTENNA POLARITY & TEST DISTANCE: VERTICAL AT 3 M								
NO.	FREQ. (MHz)	EMISSION LEVEL (dBuV/m)	LIMIT (dBuV/m)	MARGIN (dB)	ANTENNA HEIGHT (m)	TABLE ANGLE (Degree)	RAW VALUE (dBuV)	CORRECTION FACTOR (dB/m)
1	5000.00	59.2 PK	74.0	-14.8	1.38 V	139	54.9	4.3
2	5000.00	46.5 AV	54.0	-7.5	1.38 V	139	42.2	4.3
3	5103.00	61.3 PK	74.0	-12.7	1.50 V	29	56.9	4.4
4	5103.00	47.7 AV	54.0	-6.3	1.50 V	29	43.3	4.4
5	*5260.00	113.5 PK			1.45 V	359	70.6	42.9
6	*5260.00	103.5 AV			1.45 V	359	60.6	42.9
7	5418.00	62.2 PK	74.0	-11.8	1.55 V	65	57.4	4.8
8	5418.00	49.8 AV	54.0	-4.2	1.55 V	65	45.0	4.8
9	#7013.00	56.7 PK	74.0	-17.3	1.57 V	342	46.7	10.0
10	#7013.00	46.8 AV	54.0	-7.2	1.57 V	342	36.8	10.0
11	#10520.00	62.5 PK	74.0	-11.5	1.06 V	226	46.5	16.0
12	#10520.00	48.4 AV	54.0	-5.6	1.06 V	226	32.4	16.0

Remark:

1. Emission Level(dBuV/m) = Raw Value(dBuV) + Correction Factor(dB/m)
2. Correction Factor(dB/m) = Antenna Factor(dB/m) + Cable Factor(dB)
– Pre-Amplifier Factor(dB)
3. The other emission levels were very low against the limit.
4. Margin value = Emission Level – Limit value
5. " * ": Fundamental frequency.
6. " # ": The radiated frequency is out of the restricted band.

CHANNEL	TX Channel 60	DETECTOR FUNCTION	Peak (PK)
FREQUENCY RANGE	1GHz ~ 40GHz		Average (AV)

ANTENNA POLARITY & TEST DISTANCE: HORIZONTAL AT 3 M								
NO.	FREQ. (MHz)	EMISSION LEVEL (dBuV/m)	LIMIT (dBuV/m)	MARGIN (dB)	ANTENNA HEIGHT (m)	TABLE ANGLE (Degree)	RAW VALUE (dBuV)	CORRECTION FACTOR (dB/m)
1	5000.00	60.8 PK	74.0	-13.2	1.58 H	63	56.5	4.3
2	5000.00	50.7 AV	54.0	-3.3	1.58 H	63	46.4	4.3
3	*5300.00	111.0 PK			1.91 H	60	68.1	42.9
4	*5300.00	101.5 AV			1.91 H	60	58.6	42.9
5	5378.00	64.7 PK	74.0	-9.3	3.03 H	63	59.9	4.8
6	5378.00	52.8 AV	54.0	-1.2	3.03 H	63	48.0	4.8
7	5460.00	63.7 PK	74.0	-10.3	2.03 H	49	58.9	4.8
8	5460.00	51.4 AV	54.0	-2.6	2.03 H	49	46.6	4.8
9	10600.00	62.6 PK	74.0	-11.4	1.77 H	158	46.3	16.3
10	10600.00	48.4 AV	54.0	-5.6	1.77 H	158	32.1	16.3

ANTENNA POLARITY & TEST DISTANCE: VERTICAL AT 3 M								
NO.	FREQ. (MHz)	EMISSION LEVEL (dBuV/m)	LIMIT (dBuV/m)	MARGIN (dB)	ANTENNA HEIGHT (m)	TABLE ANGLE (Degree)	RAW VALUE (dBuV)	CORRECTION FACTOR (dB/m)
1	5000.00	58.6 PK	74.0	-15.4	1.50 V	156	54.3	4.3
2	5000.00	46.4 AV	54.0	-7.6	1.50 V	156	42.1	4.3
3	*5300.00	110.6 PK			1.45 V	358	67.7	42.9
4	*5300.00	100.5 AV			1.45 V	358	57.6	42.9
5	5378.00	63.2 PK	74.0	-10.8	1.96 V	1	58.4	4.8
6	5378.00	50.8 AV	54.0	-3.2	1.96 V	1	46.0	4.8
7	5460.00	62.1 PK	74.0	-11.9	1.38 V	64	57.3	4.8
8	5460.00	48.8 AV	54.0	-5.2	1.38 V	64	44.0	4.8
9	10600.00	62.9 PK	74.0	-11.1	1.05 V	222	46.6	16.3
10	10600.00	48.7 AV	54.0	-5.3	1.05 V	222	32.4	16.3

Remark:

1. Emission Level(dBuV/m) = Raw Value(dBuV) + Correction Factor(dB/m)
2. Correction Factor(dB/m) = Antenna Factor(dB/m) + Cable Factor(dB) – Pre-Amplifier Factor(dB)
3. The other emission levels were very low against the limit.
4. Margin value = Emission Level – Limit value
5. " * ": Fundamental frequency.
6. " # ": The radiated frequency is out of the restricted band.

CHANNEL	TX Channel 64	DETECTOR FUNCTION	Peak (PK)
FREQUENCY RANGE	1GHz ~ 40GHz		Average (AV)

ANTENNA POLARITY & TEST DISTANCE: HORIZONTAL AT 3 M

NO.	FREQ. (MHz)	EMISSION LEVEL (dBuV/m)	LIMIT (dBuV/m)	MARGIN (dB)	ANTENNA HEIGHT (m)	TABLE ANGLE (Degree)	RAW VALUE (dBuV)	CORRECTION FACTOR (dB/m)
1	5000.00	61.6 PK	74.0	-12.4	1.48 H	53	57.3	4.3
2	5000.00	51.0 AV	54.0	-3.0	1.48 H	53	46.7	4.3
3	*5320.00	112.5 PK			1.53 H	318	69.6	42.9
4	*5320.00	103.1 AV			1.53 H	318	60.2	42.9
5	5350.00	72.8 PK	74.0	-1.2	1.14 H	310	68.1	4.7
6	5350.00	51.5 AV	54.0	-2.5	1.14 H	310	46.8	4.7
7	5398.00	64.5 PK	74.0	-9.5	2.12 H	323	59.7	4.8
8	5398.00	52.8 AV	54.0	-1.2	2.12 H	323	48.0	4.8
9	#5473.00	64.6 PK	74.0	-9.4	2.03 H	321	59.7	4.9
10	#5473.00	52.1 AV	54.0	-1.9	2.03 H	321	47.2	4.9
11	10640.00	60.9 PK	74.0	-13.1	1.96 H	135	44.5	16.4
12	10640.00	47.2 AV	54.0	-6.8	1.96 H	135	30.8	16.4

ANTENNA POLARITY & TEST DISTANCE: VERTICAL AT 3 M

NO.	FREQ. (MHz)	EMISSION LEVEL (dBuV/m)	LIMIT (dBuV/m)	MARGIN (dB)	ANTENNA HEIGHT (m)	TABLE ANGLE (Degree)	RAW VALUE (dBuV)	CORRECTION FACTOR (dB/m)
1	5000.00	58.9 PK	74.0	-15.1	1.43 V	145	54.6	4.3
2	5000.00	46.3 AV	54.0	-7.7	1.43 V	145	42.0	4.3
3	*5320.00	113.9 PK			1.32 V	269	71.0	42.9
4	*5320.00	103.9 AV			1.32 V	269	61.0	42.9
5	5350.00	70.2 PK	74.0	-3.8	1.16 V	352	65.5	4.7
6	5350.00	52.3 AV	54.0	-1.7	1.16 V	352	47.6	4.7
7	5398.00	63.7 PK	74.0	-10.3	1.08 V	267	58.9	4.8
8	5398.00	51.9 AV	54.0	-2.1	1.08 V	267	47.1	4.8
9	#5473.00	62.9 PK	74.0	-11.1	1.20 V	332	58.0	4.9
10	#5473.00	49.2 AV	54.0	-4.8	1.20 V	332	44.3	4.9
11	10640.00	60.9 PK	74.0	-13.1	1.00 V	215	44.5	16.4
12	10640.00	47.0 AV	54.0	-7.0	1.00 V	215	30.6	16.4

Remark:

1. Emission Level(dBuV/m) = Raw Value(dBuV) + Correction Factor(dB/m)
2. Correction Factor(dB/m) = Antenna Factor(dB/m) + Cable Factor(dB)
– Pre-Amplifier Factor(dB)
3. The other emission levels were very low against the limit.
4. Margin value = Emission Level – Limit value
5. " * ": Fundamental frequency.
6. " # ": The radiated frequency is out of the restricted band.

CHANNEL	TX Channel 100	DETECTOR FUNCTION	Peak (PK)
FREQUENCY RANGE	1GHz ~ 40GHz		Average (AV)

ANTENNA POLARITY & TEST DISTANCE: HORIZONTAL AT 3 M								
NO.	FREQ. (MHz)	EMISSION LEVEL (dBuV/m)	LIMIT (dBuV/m)	MARGIN (dB)	ANTENNA HEIGHT (m)	TABLE ANGLE (Degree)	RAW VALUE (dBuV)	CORRECTION FACTOR (dB/m)
1	5417.00	62.9 PK	74.0	-11.1	1.22 H	11	58.1	4.8
2	5417.00	52.5 AV	54.0	-1.5	1.22 H	11	47.7	4.8
3	#5470.00	72.1 PK	74.0	-1.9	1.41 H	327	67.2	4.9
4	#5470.00	52.7 AV	54.0	-1.3	1.41 H	327	47.8	4.9
5	*5500.00	113.4 PK			2.24 H	8	70.2	43.2
6	*5500.00	103.5 AV			2.24 H	8	60.3	43.2
7	11000.00	62.4 PK	74.0	-11.6	1.64 H	246	45.1	17.3
8	11000.00	49.2 AV	54.0	-4.8	1.64 H	246	31.9	17.3
ANTENNA POLARITY & TEST DISTANCE: VERTICAL AT 3 M								
NO.	FREQ. (MHz)	EMISSION LEVEL (dBuV/m)	LIMIT (dBuV/m)	MARGIN (dB)	ANTENNA HEIGHT (m)	TABLE ANGLE (Degree)	RAW VALUE (dBuV)	CORRECTION FACTOR (dB/m)
1	5417.00	62.2 PK	74.0	-11.8	1.32 V	272	57.4	4.8
2	5417.00	50.7 AV	54.0	-3.3	1.32 V	272	45.9	4.8
3	#5470.00	68.9 PK	74.0	-5.1	1.62 V	271	64.0	4.9
4	#5470.00	51.6 AV	54.0	-2.4	1.62 V	271	46.7	4.9
5	*5500.00	111.8 PK			1.49 V	327	68.6	43.2
6	*5500.00	102.6 AV			1.49 V	327	59.4	43.2
7	11000.00	62.1 PK	74.0	-11.9	1.77 V	276	44.8	17.3
8	11000.00	49.0 AV	54.0	-5.0	1.77 V	276	31.7	17.3

Remark:

1. Emission Level(dBuV/m) = Raw Value(dBuV) + Correction Factor(dB/m)
2. Correction Factor(dB/m) = Antenna Factor(dB/m) + Cable Factor(dB)
– Pre-Amplifier Factor(dB)
3. The other emission levels were very low against the limit.
4. Margin value = Emission Level – Limit value
5. " * ": Fundamental frequency.
6. " # ": The radiated frequency is out of the restricted band.

CHANNEL	TX Channel 116	DETECTOR FUNCTION	Peak (PK)
FREQUENCY RANGE	1GHz ~ 40GHz		Average (AV)

ANTENNA POLARITY & TEST DISTANCE: HORIZONTAL AT 3 M								
NO.	FREQ. (MHz)	EMISSION LEVEL (dBuV/m)	LIMIT (dBuV/m)	MARGIN (dB)	ANTENNA HEIGHT (m)	TABLE ANGLE (Degree)	RAW VALUE (dBuV)	CORRECTION FACTOR (dB/m)
1	5422.00	61.7 PK	74.0	-12.3	1.34 H	6	56.9	4.8
2	5422.00	49.4 AV	54.0	-4.6	1.34 H	6	44.6	4.8
3	*5580.00	116.4 PK			1.74 H	318	73.0	43.4
4	*5580.00	106.6 AV			1.74 H	318	63.2	43.4
5	#5737.00	60.9 PK	74.0	-13.1	1.51 H	317	55.7	5.2
6	#5737.00	48.2 AV	54.0	-5.8	1.51 H	317	43.0	5.2
7	11160.00	61.9 PK	74.0	-12.1	1.62 H	181	45.3	16.6
8	11160.00	48.9 AV	54.0	-5.1	1.62 H	181	32.3	16.6
ANTENNA POLARITY & TEST DISTANCE: VERTICAL AT 3 M								
NO.	FREQ. (MHz)	EMISSION LEVEL (dBuV/m)	LIMIT (dBuV/m)	MARGIN (dB)	ANTENNA HEIGHT (m)	TABLE ANGLE (Degree)	RAW VALUE (dBuV)	CORRECTION FACTOR (dB/m)
1	5422.00	59.4 PK	74.0	-14.6	1.69 V	251	54.6	4.8
2	5422.00	47.1 AV	54.0	-6.9	1.69 V	251	42.3	4.8
3	*5580.00	111.3 PK			1.65 V	328	67.9	43.4
4	*5580.00	101.9 AV			1.65 V	328	58.5	43.4
5	#5737.00	58.8 PK	74.0	-15.2	1.21 V	359	53.6	5.2
6	#5737.00	46.7 AV	54.0	-7.3	1.21 V	359	41.5	5.2
7	11160.00	61.5 PK	74.0	-12.5	1.88 V	194	44.9	16.6
8	11160.00	48.2 AV	54.0	-5.8	1.88 V	194	31.6	16.6

Remark:

1. Emission Level(dBuV/m) = Raw Value(dBuV) + Correction Factor(dB/m)
2. Correction Factor(dB/m) = Antenna Factor(dB/m) + Cable Factor(dB)
– Pre-Amplifier Factor(dB)
3. The other emission levels were very low against the limit.
4. Margin value = Emission Level – Limit value
5. " * ": Fundamental frequency.
6. " # ": The radiated frequency is out of the restricted band.

CHANNEL	TX Channel 140	DETECTOR FUNCTION	Peak (PK)
FREQUENCY RANGE	1GHz ~ 40GHz		Average (AV)

ANTENNA POLARITY & TEST DISTANCE: HORIZONTAL AT 3 M

NO.	FREQ. (MHz)	EMISSION LEVEL (dBuV/m)	LIMIT (dBuV/m)	MARGIN (dB)	ANTENNA HEIGHT (m)	TABLE ANGLE (Degree)	RAW VALUE (dBuV)	CORRECTION FACTOR (dB/m)
1	*5700.00	112.0 PK			1.69 H	316	68.5	43.5
2	*5700.00	102.4 AV			1.69 H	316	58.9	43.5
3	#5725.00	69.7 PK	74.0	-4.3	1.98 H	284	64.6	5.1
4	#5725.00	52.7 AV	54.0	-1.3	1.98 H	284	47.6	5.1
5	11400.00	62.0 PK	74.0	-12.0	1.77 H	210	45.5	16.5
6	11400.00	49.7 AV	54.0	-4.3	1.77 H	210	33.2	16.5

ANTENNA POLARITY & TEST DISTANCE: VERTICAL AT 3 M

NO.	FREQ. (MHz)	EMISSION LEVEL (dBuV/m)	LIMIT (dBuV/m)	MARGIN (dB)	ANTENNA HEIGHT (m)	TABLE ANGLE (Degree)	RAW VALUE (dBuV)	CORRECTION FACTOR (dB/m)
1	*5700.00	111.7 PK			1.98 V	256	68.2	43.5
2	*5700.00	102.0 AV			1.98 V	256	58.5	43.5
3	#5725.00	68.3 PK	74.0	-5.7	1.61 V	235	63.2	5.1
4	#5725.00	51.3 AV	54.0	-2.7	1.61 V	235	46.2	5.1
5	11400.00	61.6 PK	74.0	-12.4	1.53 V	232	45.1	16.5
6	11400.00	49.1 AV	54.0	-4.9	1.53 V	232	32.6	16.5

Remark:

1. Emission Level(dBuV/m) = Raw Value(dBuV) + Correction Factor(dB/m)
2. Correction Factor(dB/m) = Antenna Factor(dB/m) + Cable Factor(dB)
– Pre-Amplifier Factor(dB)
3. The other emission levels were very low against the limit.
4. Margin value = Emission Level – Limit value
5. " * ": Fundamental frequency.
6. " # ": The radiated frequency is out of the restricted band.

802.11n (HT20)

CHANNEL	TX Channel 52	DETECTOR FUNCTION	Peak (PK)
FREQUENCY RANGE	1GHz ~ 40GHz		Average (AV)

ANTENNA POLARITY & TEST DISTANCE: HORIZONTAL AT 3 M

NO.	FREQ. (MHz)	EMISSION LEVEL (dBuV/m)	LIMIT (dBuV/m)	MARGIN (dB)	ANTENNA HEIGHT (m)	TABLE ANGLE (Degree)	RAW VALUE (dBuV)	CORRECTION FACTOR (dB/m)
1	5099.00	58.9 PK	74.0	-15.1	1.53 H	2	54.5	4.4
2	5099.00	46.6 AV	54.0	-7.4	1.53 H	2	42.2	4.4
3	*5260.00	111.9 PK			1.50 H	18	69.0	42.9
4	*5260.00	102.2 AV			1.50 H	18	59.3	42.9
5	5419.00	61.8 PK	74.0	-12.2	2.08 H	322	57.0	4.8
6	5419.00	50.7 AV	54.0	-3.3	2.08 H	322	45.9	4.8
7	#10520.00	60.1 PK	74.0	-13.9	1.72 H	211	44.1	16.0
8	#10520.00	47.1 AV	54.0	-6.9	1.72 H	211	31.1	16.0

ANTENNA POLARITY & TEST DISTANCE: VERTICAL AT 3 M

NO.	FREQ. (MHz)	EMISSION LEVEL (dBuV/m)	LIMIT (dBuV/m)	MARGIN (dB)	ANTENNA HEIGHT (m)	TABLE ANGLE (Degree)	RAW VALUE (dBuV)	CORRECTION FACTOR (dB/m)
1	5099.00	58.8 PK	74.0	-15.2	1.53 V	9	54.4	4.4
2	5099.00	46.1 AV	54.0	-7.9	1.53 V	9	41.7	4.4
3	*5260.00	111.3 PK			1.41 V	282	68.4	42.9
4	*5260.00	100.8 AV			1.41 V	282	57.9	42.9
5	5419.00	58.9 PK	74.0	-15.1	1.52 V	7	54.1	4.8
6	5419.00	47.0 AV	54.0	-7.0	1.52 V	7	42.2	4.8
7	#10520.00	60.4 PK	74.0	-13.6	1.58 V	223	44.4	16.0
8	#10520.00	47.4 AV	54.0	-6.6	1.58 V	223	31.4	16.0

Remark:

1. Emission Level(dBuV/m) = Raw Value(dBuV) + Correction Factor(dB/m)
2. Correction Factor(dB/m) = Antenna Factor(dB/m) + Cable Factor(dB)
– Pre-Amplifier Factor(dB)
3. The other emission levels were very low against the limit.
4. Margin value = Emission Level – Limit value
5. " * ": Fundamental frequency.
6. " # ": The radiated frequency is out of the restricted band.

CHANNEL	TX Channel 60	DETECTOR FUNCTION	Peak (PK)
FREQUENCY RANGE	1GHz ~ 40GHz		Average (AV)

ANTENNA POLARITY & TEST DISTANCE: HORIZONTAL AT 3 M								
NO.	FREQ. (MHz)	EMISSION LEVEL (dBuV/m)	LIMIT (dBuV/m)	MARGIN (dB)	ANTENNA HEIGHT (m)	TABLE ANGLE (Degree)	RAW VALUE (dBuV)	CORRECTION FACTOR (dB/m)
1	5000.00	59.8 PK	74.0	-14.2	1.72 H	87	55.5	4.3
2	5000.00	48.4 AV	54.0	-5.6	1.72 H	87	44.1	4.3
3	*5300.00	111.8 PK			2.14 H	322	68.9	42.9
4	*5300.00	102.3 AV			2.14 H	322	59.4	42.9
5	5378.00	64.6 PK	74.0	-9.4	2.04 H	322	59.8	4.8
6	5378.00	53.0 AV	54.0	-1.0	2.04 H	322	48.2	4.8
7	10600.00	61.2 PK	74.0	-12.8	1.27 H	42	44.9	16.3
8	10600.00	48.5 AV	54.0	-5.5	1.27 H	42	32.2	16.3

ANTENNA POLARITY & TEST DISTANCE: VERTICAL AT 3 M								
NO.	FREQ. (MHz)	EMISSION LEVEL (dBuV/m)	LIMIT (dBuV/m)	MARGIN (dB)	ANTENNA HEIGHT (m)	TABLE ANGLE (Degree)	RAW VALUE (dBuV)	CORRECTION FACTOR (dB/m)
1	5000.00	59.7 PK	74.0	-14.3	1.87 V	222	55.4	4.3
2	5000.00	47.0 AV	54.0	-7.0	1.87 V	222	42.7	4.3
3	*5300.00	111.7 PK			1.58 V	278	68.8	42.9
4	*5300.00	101.2 AV			1.58 V	278	58.3	42.9
5	5378.00	62.4 PK	74.0	-11.6	1.83 V	273	57.6	4.8
6	5378.00	51.2 AV	54.0	-2.8	1.83 V	273	46.4	4.8
7	10600.00	61.5 PK	74.0	-12.5	1.98 V	124	45.2	16.3
8	10600.00	48.6 AV	54.0	-5.4	1.98 V	124	32.3	16.3

Remark:

1. Emission Level(dBuV/m) = Raw Value(dBuV) + Correction Factor(dB/m)
2. Correction Factor(dB/m) = Antenna Factor(dB/m) + Cable Factor(dB) – Pre-Amplifier Factor(dB)
3. The other emission levels were very low against the limit.
4. Margin value = Emission Level – Limit value
5. " * ": Fundamental frequency.
6. " # ": The radiated frequency is out of the restricted band.

CHANNEL	TX Channel 64	DETECTOR FUNCTION	Peak (PK)
FREQUENCY RANGE	1GHz ~ 40GHz		Average (AV)

ANTENNA POLARITY & TEST DISTANCE: HORIZONTAL AT 3 M

NO.	FREQ. (MHz)	EMISSION LEVEL (dBuV/m)	LIMIT (dBuV/m)	MARGIN (dB)	ANTENNA HEIGHT (m)	TABLE ANGLE (Degree)	RAW VALUE (dBuV)	CORRECTION FACTOR (dB/m)
1	5000.00	60.4 PK	74.0	-13.6	1.42 H	324	56.1	4.3
2	5000.00	49.4 AV	54.0	-4.6	1.42 H	324	45.1	4.3
3	*5320.00	111.5 PK			2.35 H	324	68.6	42.9
4	*5320.00	101.8 AV			2.35 H	324	58.9	42.9
5	5350.00	70.1 PK	74.0	-3.9	2.24 H	316	65.4	4.7
6	5350.00	52.3 AV	54.0	-1.7	2.24 H	316	47.6	4.7
7	10640.00	61.5 PK	74.0	-12.5	1.28 H	233	45.1	16.4
8	10640.00	48.6 AV	54.0	-5.4	1.28 H	233	32.2	16.4

ANTENNA POLARITY & TEST DISTANCE: VERTICAL AT 3 M

NO.	FREQ. (MHz)	EMISSION LEVEL (dBuV/m)	LIMIT (dBuV/m)	MARGIN (dB)	ANTENNA HEIGHT (m)	TABLE ANGLE (Degree)	RAW VALUE (dBuV)	CORRECTION FACTOR (dB/m)
1	5000.00	58.0 PK	74.0	-16.0	1.52 V	138	53.7	4.3
2	5000.00	46.0 AV	54.0	-8.0	1.52 V	138	41.7	4.3
3	*5320.00	111.2 PK			1.27 V	8	68.3	42.9
4	*5320.00	99.9 AV			1.27 V	8	57.0	42.9
5	5350.00	72.6 PK	74.0	-1.4	1.21 V	269	67.9	4.7
6	5350.00	50.8 AV	54.0	-3.2	1.21 V	269	46.1	4.7
7	10640.00	61.2 PK	74.0	-12.8	1.88 V	221	44.8	16.4
8	10640.00	48.4 AV	54.0	-5.6	1.88 V	221	32.0	16.4

Remark:

1. Emission Level(dBuV/m) = Raw Value(dBuV) + Correction Factor(dB/m)
2. Correction Factor(dB/m) = Antenna Factor(dB/m) + Cable Factor(dB)
– Pre-Amplifier Factor(dB)
3. The other emission levels were very low against the limit.
4. Margin value = Emission Level – Limit value
5. " * ": Fundamental frequency.
6. " # ": The radiated frequency is out of the restricted band.

CHANNEL	TX Channel 100	DETECTOR FUNCTION	Peak (PK)
FREQUENCY RANGE	1GHz ~ 40GHz		Average (AV)

ANTENNA POLARITY & TEST DISTANCE: HORIZONTAL AT 3 M								
NO.	FREQ. (MHz)	EMISSION LEVEL (dBuV/m)	LIMIT (dBuV/m)	MARGIN (dB)	ANTENNA HEIGHT (m)	TABLE ANGLE (Degree)	RAW VALUE (dBuV)	CORRECTION FACTOR (dB/m)
1	5418.00	63.7 PK	74.0	-10.3	1.44 H	322	58.9	4.8
2	5418.00	52.0 AV	54.0	-2.0	1.44 H	322	47.2	4.8
3	#5470.00	71.0 PK	74.0	-3.0	2.24 H	322	66.1	4.9
4	#5470.00	53.0 AV	54.0	-1.0	2.24 H	322	48.1	4.9
5	*5500.00	114.4 PK			2.04 H	234	71.2	43.2
6	*5500.00	104.7 AV			2.04 H	234	61.5	43.2
7	11000.00	63.2 PK	74.0	-10.8	1.24 H	242	45.9	17.3
8	11000.00	49.5 AV	54.0	-4.5	1.24 H	242	32.2	17.3
ANTENNA POLARITY & TEST DISTANCE: VERTICAL AT 3 M								
NO.	FREQ. (MHz)	EMISSION LEVEL (dBuV/m)	LIMIT (dBuV/m)	MARGIN (dB)	ANTENNA HEIGHT (m)	TABLE ANGLE (Degree)	RAW VALUE (dBuV)	CORRECTION FACTOR (dB/m)
1	5418.00	61.0 PK	74.0	-13.0	1.32 V	55	56.2	4.8
2	5418.00	50.1 AV	54.0	-3.9	1.32 V	55	45.3	4.8
3	#5470.00	69.1 PK	74.0	-4.9	2.35 V	248	64.2	4.9
4	#5470.00	51.1 AV	54.0	-2.9	2.35 V	248	46.2	4.9
5	*5500.00	110.5 PK			1.80 V	354	67.3	43.2
6	*5500.00	99.9 AV			1.80 V	354	56.7	43.2
7	11000.00	62.6 PK	74.0	-11.4	1.47 V	253	45.3	17.3
8	11000.00	49.1 AV	54.0	-4.9	1.47 V	253	31.8	17.3

Remark:

1. Emission Level(dBuV/m) = Raw Value(dBuV) + Correction Factor(dB/m)
2. Correction Factor(dB/m) = Antenna Factor(dB/m) + Cable Factor(dB)
– Pre-Amplifier Factor(dB)
3. The other emission levels were very low against the limit.
4. Margin value = Emission Level – Limit value
5. " * ": Fundamental frequency.
6. " # ": The radiated frequency is out of the restricted band.

CHANNEL	TX Channel 116	DETECTOR FUNCTION	Peak (PK)
FREQUENCY RANGE	1GHz ~ 40GHz		Average (AV)

ANTENNA POLARITY & TEST DISTANCE: HORIZONTAL AT 3 M								
NO.	FREQ. (MHz)	EMISSION LEVEL (dBuV/m)	LIMIT (dBuV/m)	MARGIN (dB)	ANTENNA HEIGHT (m)	TABLE ANGLE (Degree)	RAW VALUE (dBuV)	CORRECTION FACTOR (dB/m)
1	5418.00	60.8 PK	74.0	-13.2	1.47 H	18	56.0	4.8
2	5418.00	48.5 AV	54.0	-5.5	1.47 H	18	43.7	4.8
3	*5580.00	115.4 PK			2.32 H	322	72.0	43.4
4	*5580.00	107.0 AV			2.32 H	322	63.6	43.4
5	#5738.00	60.8 PK	74.0	-13.2	1.51 H	212	55.6	5.2
6	#5738.00	49.4 AV	54.0	-4.6	1.51 H	212	44.2	5.2
7	11160.00	62.8 PK	74.0	-11.2	1.57 H	233	46.2	16.6
8	11160.00	49.3 AV	54.0	-4.7	1.57 H	233	32.7	16.6
ANTENNA POLARITY & TEST DISTANCE: VERTICAL AT 3 M								
NO.	FREQ. (MHz)	EMISSION LEVEL (dBuV/m)	LIMIT (dBuV/m)	MARGIN (dB)	ANTENNA HEIGHT (m)	TABLE ANGLE (Degree)	RAW VALUE (dBuV)	CORRECTION FACTOR (dB/m)
1	5418.00	59.9 PK	74.0	-14.1	1.88 V	34	55.1	4.8
2	5418.00	47.4 AV	54.0	-6.6	1.88 V	34	42.6	4.8
3	*5580.00	114.8 PK			1.68 V	177	71.4	43.4
4	*5580.00	106.2 AV			1.68 V	177	62.8	43.4
5	#5738.00	60.0 PK	74.0	-14.0	1.35 V	238	54.8	5.2
6	#5738.00	48.9 AV	54.0	-5.1	1.35 V	238	43.7	5.2
7	11160.00	62.3 PK	74.0	-11.7	2.58 V	147	45.7	16.6
8	11160.00	48.6 AV	54.0	-5.4	2.58 V	147	32.0	16.6

Remark:

1. Emission Level(dBuV/m) = Raw Value(dBuV) + Correction Factor(dB/m)
2. Correction Factor(dB/m) = Antenna Factor(dB/m) + Cable Factor(dB)
– Pre-Amplifier Factor(dB)
3. The other emission levels were very low against the limit.
4. Margin value = Emission Level – Limit value
5. " * ": Fundamental frequency.
6. " # ": The radiated frequency is out of the restricted band.

CHANNEL	TX Channel 140	DETECTOR FUNCTION	Peak (PK)
FREQUENCY RANGE	1GHz ~ 40GHz		Average (AV)

ANTENNA POLARITY & TEST DISTANCE: HORIZONTAL AT 3 M

NO.	FREQ. (MHz)	EMISSION LEVEL (dBuV/m)	LIMIT (dBuV/m)	MARGIN (dB)	ANTENNA HEIGHT (m)	TABLE ANGLE (Degree)	RAW VALUE (dBuV)	CORRECTION FACTOR (dB/m)
1	*5700.00	111.4 PK			1.84 H	322	67.9	43.5
2	*5700.00	101.9 AV			1.84 H	322	58.4	43.5
3	#5725.00	68.8 PK	74.0	-5.2	1.48 H	258	63.7	5.1
4	#5725.00	52.7 AV	54.0	-1.3	1.48 H	258	47.6	5.1
5	11400.00	62.4 PK	74.0	-11.6	1.84 H	251	45.9	16.5
6	11400.00	48.9 AV	54.0	-5.1	1.84 H	251	32.4	16.5

ANTENNA POLARITY & TEST DISTANCE: VERTICAL AT 3 M

NO.	FREQ. (MHz)	EMISSION LEVEL (dBuV/m)	LIMIT (dBuV/m)	MARGIN (dB)	ANTENNA HEIGHT (m)	TABLE ANGLE (Degree)	RAW VALUE (dBuV)	CORRECTION FACTOR (dB/m)
1	*5700.00	106.1 PK			1.48 V	231	62.6	43.5
2	*5700.00	89.7 AV			1.48 V	231	46.2	43.5
3	#5725.00	63.1 PK	74.0	-10.9	1.91 V	278	58.0	5.1
4	#5725.00	49.4 AV	54.0	-4.6	1.91 V	278	44.3	5.1
5	11400.00	61.8 PK	74.0	-12.2	2.35 V	244	45.3	16.5
6	11400.00	48.6 AV	54.0	-5.4	2.35 V	244	32.1	16.5

Remark:

1. Emission Level(dBuV/m) = Raw Value(dBuV) + Correction Factor(dB/m)
2. Correction Factor(dB/m) = Antenna Factor(dB/m) + Cable Factor(dB)
– Pre-Amplifier Factor(dB)
3. The other emission levels were very low against the limit.
4. Margin value = Emission Level – Limit value
5. " * ": Fundamental frequency.
6. " # ": The radiated frequency is out of the restricted band.

802.11n (HT40)

CHANNEL	TX Channel 54	DETECTOR FUNCTION	Peak (PK)
FREQUENCY RANGE	1GHz ~ 40GHz		Average (AV)

ANTENNA POLARITY & TEST DISTANCE: HORIZONTAL AT 3 M

NO.	FREQ. (MHz)	EMISSION LEVEL (dBuV/m)	LIMIT (dBuV/m)	MARGIN (dB)	ANTENNA HEIGHT (m)	TABLE ANGLE (Degree)	RAW VALUE (dBuV)	CORRECTION FACTOR (dB/m)
1	5000.00	59.2 PK	74.0	-14.8	1.69 H	318	54.9	4.3
2	5000.00	48.9 AV	54.0	-5.1	1.69 H	318	44.6	4.3
3	*5270.00	108.6 PK			2.23 H	324	65.7	42.9
4	*5270.00	99.2 AV			2.23 H	324	56.3	42.9
5	5350.00	59.5 PK	74.0	-14.5	1.55 H	14	54.8	4.7
6	5350.00	49.6 AV	54.0	-4.4	1.55 H	14	44.9	4.7
7	#10540.00	60.9 PK	74.0	-13.1	1.67 H	28	44.7	16.2
8	#10540.00	48.4 AV	54.0	-5.6	1.67 H	28	32.2	16.2

ANTENNA POLARITY & TEST DISTANCE: VERTICAL AT 3 M

NO.	FREQ. (MHz)	EMISSION LEVEL (dBuV/m)	LIMIT (dBuV/m)	MARGIN (dB)	ANTENNA HEIGHT (m)	TABLE ANGLE (Degree)	RAW VALUE (dBuV)	CORRECTION FACTOR (dB/m)
1	5000.00	57.6 PK	74.0	-16.4	1.57 V	122	53.3	4.3
2	5000.00	45.8 AV	54.0	-8.2	1.57 V	122	41.5	4.3
3	*5270.00	109.4 PK			1.41 V	278	66.5	42.9
4	*5270.00	98.5 AV			1.41 V	278	55.6	42.9
5	5350.00	60.7 PK	74.0	-13.3	2.05 V	276	56.0	4.7
6	5350.00	48.5 AV	54.0	-5.5	2.05 V	276	43.8	4.7
7	#10540.00	60.9 PK	74.0	-13.1	1.56 V	32	44.7	16.2
8	#10540.00	48.3 AV	54.0	-5.7	1.56 V	32	32.1	16.2

Remark:

1. Emission Level(dBuV/m) = Raw Value(dBuV) + Correction Factor(dB/m)
2. Correction Factor(dB/m) = Antenna Factor(dB/m) + Cable Factor(dB)
– Pre-Amplifier Factor(dB)
3. The other emission levels were very low against the limit.
4. Margin value = Emission Level – Limit value
5. " * ": Fundamental frequency.
6. " # ": The radiated frequency is out of the restricted band.

CHANNEL	TX Channel 62	DETECTOR FUNCTION	Peak (PK)
FREQUENCY RANGE	1GHz ~ 40GHz		Average (AV)

ANTENNA POLARITY & TEST DISTANCE: HORIZONTAL AT 3 M

NO.	FREQ. (MHz)	EMISSION LEVEL (dBuV/m)	LIMIT (dBuV/m)	MARGIN (dB)	ANTENNA HEIGHT (m)	TABLE ANGLE (Degree)	RAW VALUE (dBuV)	CORRECTION FACTOR (dB/m)
1	5000.00	58.9 PK	74.0	-15.1	2.21 H	213	54.6	4.3
2	5000.00	46.5 AV	54.0	-7.5	2.21 H	213	42.2	4.3
3	*5310.00	105.2 PK			1.96 H	312	62.3	42.9
4	*5310.00	95.6 AV			1.96 H	312	52.7	42.9
5	5350.00	72.0 PK	74.0	-2.0	1.90 H	3	67.3	4.7
6	5350.00	51.8 AV	54.0	-2.2	1.90 H	3	47.1	4.7
7	10620.00	61.4 PK	74.0	-12.6	1.77 H	189	44.9	16.5
8	10620.00	48.8 AV	54.0	-5.2	1.77 H	189	32.3	16.5

ANTENNA POLARITY & TEST DISTANCE: VERTICAL AT 3 M

NO.	FREQ. (MHz)	EMISSION LEVEL (dBuV/m)	LIMIT (dBuV/m)	MARGIN (dB)	ANTENNA HEIGHT (m)	TABLE ANGLE (Degree)	RAW VALUE (dBuV)	CORRECTION FACTOR (dB/m)
1	5000.00	58.9 PK	74.0	-15.1	1.77 V	351	54.6	4.3
2	5000.00	45.9 AV	54.0	-8.1	1.77 V	351	41.6	4.3
3	*5310.00	105.5 PK			1.70 V	274	62.6	42.9
4	*5310.00	94.6 AV			1.70 V	274	51.7	42.9
5	5350.00	72.8 PK	74.0	-1.2	1.50 V	271	68.1	4.7
6	5350.00	53.0 AV	54.0	-1.0	1.50 V	271	48.3	4.7
7	10620.00	61.2 PK	74.0	-12.8	1.87 V	87	44.7	16.5
8	10620.00	48.4 AV	54.0	-5.6	1.87 V	87	31.9	16.5

Remark:

1. Emission Level(dBuV/m) = Raw Value(dBuV) + Correction Factor(dB/m)
2. Correction Factor(dB/m) = Antenna Factor(dB/m) + Cable Factor(dB)
– Pre-Amplifier Factor(dB)
3. The other emission levels were very low against the limit.
4. Margin value = Emission Level – Limit value
5. " * ": Fundamental frequency.
6. " # ": The radiated frequency is out of the restricted band.

CHANNEL	TX Channel 102	DETECTOR FUNCTION	Peak (PK)
FREQUENCY RANGE	1GHz ~ 40GHz		Average (AV)

ANTENNA POLARITY & TEST DISTANCE: HORIZONTAL AT 3 M								
NO.	FREQ. (MHz)	EMISSION LEVEL (dBuV/m)	LIMIT (dBuV/m)	MARGIN (dB)	ANTENNA HEIGHT (m)	TABLE ANGLE (Degree)	RAW VALUE (dBuV)	CORRECTION FACTOR (dB/m)
1	5418.00	60.2 PK	74.0	-13.8	1.53 H	3	55.4	4.8
2	5418.00	48.4 AV	54.0	-5.6	1.53 H	3	43.6	4.8
3	#5470.00	71.3 PK	74.0	-2.7	2.48 H	329	66.4	4.9
4	#5470.00	52.4 AV	54.0	-1.6	2.48 H	329	47.5	4.9
5	*5510.00	107.6 PK			2.35 H	323	64.4	43.2
6	*5510.00	98.4 AV			2.35 H	323	55.2	43.2
7	11020.00	62.5 PK	74.0	-11.5	1.62 H	133	45.3	17.2
8	11020.00	49.8 AV	54.0	-4.2	1.62 H	133	32.6	17.2
ANTENNA POLARITY & TEST DISTANCE: VERTICAL AT 3 M								
NO.	FREQ. (MHz)	EMISSION LEVEL (dBuV/m)	LIMIT (dBuV/m)	MARGIN (dB)	ANTENNA HEIGHT (m)	TABLE ANGLE (Degree)	RAW VALUE (dBuV)	CORRECTION FACTOR (dB/m)
1	5417.00	58.0 PK	74.0	-16.0	1.58 V	257	53.2	4.8
2	5417.00	47.0 AV	54.0	-7.0	1.58 V	257	42.2	4.8
3	#5470.00	69.0 PK	74.0	-5.0	1.56 V	298	64.1	4.9
4	#5470.00	48.7 AV	54.0	-5.3	1.56 V	298	43.8	4.9
5	*5510.00	107.0 PK			2.56 V	287	63.8	43.2
6	*5510.00	97.8 AV			2.56 V	287	54.6	43.2
7	11020.00	61.9 PK	74.0	-12.1	1.44 V	165	44.7	17.2
8	11020.00	49.3 AV	54.0	-4.7	1.44 V	165	32.1	17.2

Remark:

1. Emission Level(dBuV/m) = Raw Value(dBuV) + Correction Factor(dB/m)
2. Correction Factor(dB/m) = Antenna Factor(dB/m) + Cable Factor(dB)
– Pre-Amplifier Factor(dB)
3. The other emission levels were very low against the limit.
4. Margin value = Emission Level – Limit value
5. " * ": Fundamental frequency.
6. " # ": The radiated frequency is out of the restricted band.

CHANNEL	TX Channel 110	DETECTOR FUNCTION	Peak (PK)
FREQUENCY RANGE	1GHz ~ 40GHz		Average (AV)

ANTENNA POLARITY & TEST DISTANCE: HORIZONTAL AT 3 M								
NO.	FREQ. (MHz)	EMISSION LEVEL (dBuV/m)	LIMIT (dBuV/m)	MARGIN (dB)	ANTENNA HEIGHT (m)	TABLE ANGLE (Degree)	RAW VALUE (dBuV)	CORRECTION FACTOR (dB/m)
1	5460.00	62.4 PK	74.0	-11.6	1.32 H	327	57.6	4.8
2	5460.00	51.2 AV	54.0	-2.8	1.32 H	327	46.4	4.8
3	#5470.00	68.8 PK	74.0	-5.2	2.38 H	321	63.9	4.9
4	#5470.00	52.4 AV	54.0	-1.6	2.38 H	321	47.5	4.9
5	*5550.00	112.9 PK			1.91 H	324	69.6	43.3
6	*5550.00	103.3 AV			1.91 H	324	60.0	43.3
7	#5725.00	59.8 PK	74.0	-14.2	1.50 H	45	54.7	5.1
8	#5725.00	47.3 AV	54.0	-6.7	1.50 H	45	42.2	5.1
9	11100.00	59.8 PK	74.0	-14.2	1.62 H	12	43.4	16.4
10	11100.00	48.5 AV	54.0	-5.5	1.62 H	12	32.1	16.4

ANTENNA POLARITY & TEST DISTANCE: VERTICAL AT 3 M								
NO.	FREQ. (MHz)	EMISSION LEVEL (dBuV/m)	LIMIT (dBuV/m)	MARGIN (dB)	ANTENNA HEIGHT (m)	TABLE ANGLE (Degree)	RAW VALUE (dBuV)	CORRECTION FACTOR (dB/m)
1	5460.00	61.5 PK	74.0	-12.5	1.22 V	238	56.7	4.8
2	5460.00	50.5 AV	54.0	-3.5	1.22 V	238	45.7	4.8
3	#5470.00	67.7 PK	74.0	-6.3	1.59 V	255	62.8	4.9
4	#5470.00	51.3 AV	54.0	-2.7	1.59 V	255	46.4	4.9
5	*5550.00	111.5 PK			1.93 V	231	68.2	43.3
6	*5550.00	94.7 AV			1.93 V	231	51.4	43.3
7	#5725.00	59.2 PK	74.0	-14.8	1.51 V	157	54.1	5.1
8	#5725.00	46.8 AV	54.0	-7.2	1.51 V	157	41.7	5.1
9	11100.00	59.3 PK	74.0	-14.7	1.77 V	154	42.9	16.4
10	11100.00	48.1 AV	54.0	-5.9	1.77 V	154	31.7	16.4

Remark:

1. Emission Level(dBuV/m) = Raw Value(dBuV) + Correction Factor(dB/m)
2. Correction Factor(dB/m) = Antenna Factor(dB/m) + Cable Factor(dB)
– Pre-Amplifier Factor(dB)
3. The other emission levels were very low against the limit.
4. Margin value = Emission Level – Limit value
5. " * ": Fundamental frequency.
6. " # ": The radiated frequency is out of the restricted band.

CHANNEL	TX Channel 134	DETECTOR FUNCTION	Peak (PK)
FREQUENCY RANGE	1GHz ~ 40GHz		Average (AV)

ANTENNA POLARITY & TEST DISTANCE: HORIZONTAL AT 3 M

NO.	FREQ. (MHz)	EMISSION LEVEL (dBuV/m)	LIMIT (dBuV/m)	MARGIN (dB)	ANTENNA HEIGHT (m)	TABLE ANGLE (Degree)	RAW VALUE (dBuV)	CORRECTION FACTOR (dB/m)
1	*5670.00	110.7 PK			2.02 H	319	67.2	43.5
2	*5670.00	101.3 AV			2.02 H	319	57.8	43.5
3	#5725.00	68.2 PK	74.0	-5.8	1.96 H	316	63.1	5.1
4	#5725.00	52.7 AV	54.0	-1.3	1.96 H	316	47.6	5.1
5	11340.00	61.2 PK	74.0	-12.8	2.18 H	108	44.1	17.1
6	11340.00	49.1 AV	54.0	-4.9	2.18 H	108	32.0	17.1

ANTENNA POLARITY & TEST DISTANCE: VERTICAL AT 3 M

NO.	FREQ. (MHz)	EMISSION LEVEL (dBuV/m)	LIMIT (dBuV/m)	MARGIN (dB)	ANTENNA HEIGHT (m)	TABLE ANGLE (Degree)	RAW VALUE (dBuV)	CORRECTION FACTOR (dB/m)
1	*5670.00	108.7 PK			1.23 V	138	65.2	43.5
2	*5670.00	100.2 AV			1.23 V	138	56.7	43.5
3	#5725.00	67.0 PK	74.0	-7.0	1.88 V	312	61.9	5.1
4	#5725.00	51.3 AV	54.0	-2.7	1.88 V	312	46.2	5.1
5	11340.00	60.5 PK	74.0	-13.5	2.61 V	174	43.4	17.1
6	11340.00	48.3 AV	54.0	-5.7	2.61 V	174	31.2	17.1

Remark:

1. Emission Level(dBuV/m) = Raw Value(dBuV) + Correction Factor(dB/m)
2. Correction Factor(dB/m) = Antenna Factor(dB/m) + Cable Factor(dB)
– Pre-Amplifier Factor(dB)
3. The other emission levels were very low against the limit.
4. Margin value = Emission Level – Limit value
5. " * ": Fundamental frequency.
6. " # ": The radiated frequency is out of the restricted band.

802.11ac (VHT80)

CHANNEL	TX Channel 58	DETECTOR FUNCTION	Peak (PK)
FREQUENCY RANGE	1GHz ~ 40GHz		Average (AV)

ANTENNA POLARITY & TEST DISTANCE: HORIZONTAL AT 3 M

NO.	FREQ. (MHz)	EMISSION LEVEL (dBuV/m)	LIMIT (dBuV/m)	MARGIN (dB)	ANTENNA HEIGHT (m)	TABLE ANGLE (Degree)	RAW VALUE (dBuV)	CORRECTION FACTOR (dB/m)
1	5000.00	59.8 PK	74.0	-14.2	1.57 H	321	55.5	4.3
2	5000.00	49.9 AV	54.0	-4.1	1.57 H	321	45.6	4.3
3	*5290.00	102.9 PK			2.41 H	323	60.0	42.9
4	*5290.00	93.1 AV			2.41 H	323	50.2	42.9
5	5350.00	68.7 PK	74.0	-5.3	1.64 H	4	64.0	4.7
6	5350.00	52.9 AV	54.0	-1.1	1.64 H	4	48.2	4.7
7	#10580.00	62.5 PK	74.0	-11.5	1.57 H	144	46.2	16.3
8	#10580.00	48.6 AV	54.0	-5.4	1.57 H	144	32.3	16.3

ANTENNA POLARITY & TEST DISTANCE: VERTICAL AT 3 M

NO.	FREQ. (MHz)	EMISSION LEVEL (dBuV/m)	LIMIT (dBuV/m)	MARGIN (dB)	ANTENNA HEIGHT (m)	TABLE ANGLE (Degree)	RAW VALUE (dBuV)	CORRECTION FACTOR (dB/m)
1	5000.00	57.9 PK	74.0	-16.1	1.64 V	57	53.6	4.3
2	5000.00	47.5 AV	54.0	-6.5	1.64 V	57	43.2	4.3
3	*5290.00	103.5 PK			1.51 V	277	60.6	42.9
4	*5290.00	92.0 AV			1.51 V	277	49.1	42.9
5	5350.00	67.4 PK	74.0	-6.6	1.73 V	268	62.7	4.7
6	5350.00	51.1 AV	54.0	-2.9	1.73 V	268	46.4	4.7
7	#10580.00	61.9 PK	74.0	-12.1	1.74 V	128	45.6	16.3
8	#10580.00	47.9 AV	54.0	-6.1	1.74 V	128	31.6	16.3

Remark:

1. Emission Level(dBuV/m) = Raw Value(dBuV) + Correction Factor(dB/m)
2. Correction Factor(dB/m) = Antenna Factor(dB/m) + Cable Factor(dB)
– Pre-Amplifier Factor(dB)
3. The other emission levels were very low against the limit.
4. Margin value = Emission Level – Limit value
5. " * ": Fundamental frequency.
6. " # ": The radiated frequency is out of the restricted band.

CHANNEL	TX Channel 106	DETECTOR FUNCTION	Peak (PK)
FREQUENCY RANGE	1GHz ~ 40GHz		Average (AV)

ANTENNA POLARITY & TEST DISTANCE: HORIZONTAL AT 3 M

NO.	FREQ. (MHz)	EMISSION LEVEL (dBuV/m)	LIMIT (dBuV/m)	MARGIN (dB)	ANTENNA HEIGHT (m)	TABLE ANGLE (Degree)	RAW VALUE (dBuV)	CORRECTION FACTOR (dB/m)
1	3688.00	49.2 PK	74.0	-24.8	1.30 H	238	48.3	0.9
2	3688.00	44.4 AV	54.0	-9.6	1.30 H	238	43.5	0.9
3	5460.00	63.6 PK	74.0	-10.4	1.57 H	205	58.8	4.8
4	5460.00	50.0 AV	54.0	-4.0	1.57 H	205	45.2	4.8
5	#5470.00	70.7 PK	74.0	-3.3	2.04 H	325	65.8	4.9
6	#5470.00	52.4 AV	54.0	-1.6	2.04 H	325	47.5	4.9
7	*5530.00	105.0 PK			1.98 H	324	61.8	43.2
8	*5530.00	95.0 AV			1.98 H	324	51.8	43.2
9	#5725.00	59.6 PK	74.0	-14.4	1.72 H	102	54.5	5.1
10	#5725.00	47.8 AV	54.0	-6.2	1.72 H	102	42.7	5.1
11	#6144.00	54.5 PK	74.0	-19.5	1.30 H	211	47.6	6.9
12	#6144.00	48.3 AV	54.0	-5.7	1.30 H	211	41.4	6.9
13	11060.00	61.7 PK	74.0	-12.3	1.67 H	122	44.9	16.8
14	11060.00	49.4 AV	54.0	-4.6	1.67 H	122	32.6	16.8

ANTENNA POLARITY & TEST DISTANCE: VERTICAL AT 3 M

NO.	FREQ. (MHz)	EMISSION LEVEL (dBuV/m)	LIMIT (dBuV/m)	MARGIN (dB)	ANTENNA HEIGHT (m)	TABLE ANGLE (Degree)	RAW VALUE (dBuV)	CORRECTION FACTOR (dB/m)
1	3686.66	46.6 PK	74.0	-27.4	1.99 V	271	45.80	0.80
2	3686.66	36.5 AV	54.0	-17.5	1.99 V	271	35.70	0.80
3	5460.00	64.1 PK	74.0	-9.9	1.77 V	317	59.30	4.80
4	5460.00	50.8 AV	54.0	-3.2	1.77 V	317	46.00	4.80
5	#5470.00	67.4 PK	74.0	-6.6	1.65 V	318	62.50	4.90
6	#5470.00	50.6 AV	54.0	-3.4	1.65 V	318	45.70	4.90
7	*5530.00	104.1 PK			1.71 V	318	60.90	43.20
8	*5530.00	94.4 AV			1.71 V	318	51.20	43.20
9	11060.00	62.1 PK	74.0	-11.9	4.00 V	289	45.30	16.80
10	11060.00	48.3 AV	54.0	-5.7	4.00 V	289	31.50	16.80

Remark:

1. Emission Level(dBuV/m) = Raw Value(dBuV) + Correction Factor(dB/m)
2. Correction Factor(dB/m) = Antenna Factor(dB/m) + Cable Factor(dB)
– Pre-Amplifier Factor(dB)
3. The other emission levels were very low against the limit.
4. Margin value = Emission Level – Limit value
5. " * ": Fundamental frequency.
6. " # ": The radiated frequency is out of the restricted band.

CHANNEL	TX Channel 122	DETECTOR FUNCTION	Peak (PK)
FREQUENCY RANGE	1GHz ~ 40GHz		Average (AV)

ANTENNA POLARITY & TEST DISTANCE: HORIZONTAL AT 3 M								
NO.	FREQ. (MHz)	EMISSION LEVEL (dBuV/m)	LIMIT (dBuV/m)	MARGIN (dB)	ANTENNA HEIGHT (m)	TABLE ANGLE (Degree)	RAW VALUE (dBuV)	CORRECTION FACTOR (dB/m)
1	5460.00	59.4 PK	74.0	-14.6	1.83 H	357	54.6	4.8
2	5460.00	45.8 AV	54.0	-8.2	1.83 H	357	41.0	4.8
3	#5470.00	60.6 PK	74.0	-13.4	1.67 H	327	55.7	4.9
4	#5470.00	47.3 AV	54.0	-6.7	1.67 H	327	42.4	4.9
5	*5610.00	104.8 PK			2.00 H	335	61.4	43.4
6	*5610.00	95.4 AV			2.00 H	335	52.0	43.4
7	#5850.00	58.5 PK	74.0	-15.5	2.28 H	0	53.3	5.2
8	#5850.00	45.6 AV	54.0	-8.4	2.28 H	0	40.4	5.2
9	11220.00	62.0 PK	74.0	-12.0	1.58 H	108	45.3	16.7
10	11220.00	49.1 AV	54.0	-4.9	1.58 H	108	32.4	16.7

ANTENNA POLARITY & TEST DISTANCE: VERTICAL AT 3 M								
NO.	FREQ. (MHz)	EMISSION LEVEL (dBuV/m)	LIMIT (dBuV/m)	MARGIN (dB)	ANTENNA HEIGHT (m)	TABLE ANGLE (Degree)	RAW VALUE (dBuV)	CORRECTION FACTOR (dB/m)
1	5460.00	59.2 PK	74.0	-14.8	1.76 V	300	54.4	4.8
2	5460.00	45.8 AV	54.0	-8.2	1.76 V	300	41.0	4.8
3	#5470.00	60.0 PK	74.0	-14.0	1.86 V	287	55.1	4.9
4	#5470.00	47.1 AV	54.0	-6.9	1.86 V	287	42.2	4.9
5	*5610.00	103.1 PK			1.83 V	291	59.7	43.4
6	*5610.00	93.8 AV			1.83 V	291	50.4	43.4
7	#5850.00	58.4 PK	74.0	-15.6	1.92 V	312	53.2	5.2
8	#5850.00	45.6 AV	54.0	-8.4	1.92 V	312	40.4	5.2
9	11220.00	61.8 PK	74.0	-12.2	1.00 V	215	45.1	16.7
10	11220.00	48.8 AV	54.0	-5.2	1.00 V	215	32.1	16.7

Remark:

1. Emission Level(dBuV/m) = Raw Value(dBuV) + Correction Factor(dB/m)
2. Correction Factor(dB/m) = Antenna Factor(dB/m) + Cable Factor(dB) – Pre-Amplifier Factor(dB)
3. The other emission levels were very low against the limit.
4. Margin value = Emission Level – Limit value
5. " * ": Fundamental frequency.
6. " # ": The radiated frequency is out of the restricted band.

Below 1GHz worst-case data: 802.11a

CHANNEL	TX Channel 52	DETECTOR FUNCTION	Quasi-Peak (QP)
FREQUENCY RANGE	9kHz ~ 1GHz		

ANTENNA POLARITY & TEST DISTANCE: HORIZONTAL AT 3 M								
NO.	FREQ. (MHz)	EMISSION LEVEL (dBuV/m)	LIMIT (dBuV/m)	MARGIN (dB)	ANTENNA HEIGHT (m)	TABLE ANGLE (Degree)	RAW VALUE (dBuV)	CORRECTION FACTOR (dB/m)
1	30.00	35.1 QP	40.0	-4.9	1.50 H	10	50.7	-15.6
2	125.06	32.3 QP	43.5	-11.2	2.00 H	303	47.9	-15.6
3	165.80	32.8 QP	43.5	-10.7	1.50 H	110	46.2	-13.4
4	375.32	37.8 QP	46.0	-8.2	1.04 H	228	47.1	-9.3
5	625.58	39.1 QP	46.0	-6.9	1.04 H	255	42.2	-3.1
6	875.84	41.1 QP	46.0	-4.9	1.25 H	314	38.7	2.4

ANTENNA POLARITY & TEST DISTANCE: VERTICAL AT 3 M								
NO.	FREQ. (MHz)	EMISSION LEVEL (dBuV/m)	LIMIT (dBuV/m)	MARGIN (dB)	ANTENNA HEIGHT (m)	TABLE ANGLE (Degree)	RAW VALUE (dBuV)	CORRECTION FACTOR (dB/m)
1	43.64	38.8 QP	40.0	-1.2	1.04 V	15	53.0	-14.2
2	95.96	32.4 QP	43.5	-11.1	1.00 V	239	51.3	-18.9
3	499.48	36.2 QP	46.0	-9.8	1.00 V	10	42.7	-6.5
4	625.58	36.1 QP	46.0	-9.9	1.50 V	266	39.2	-3.1
5	875.84	38.1 QP	46.0	-7.9	1.00 V	249	35.7	2.4
6	955.38	36.5 QP	46.0	-9.5	1.99 V	18	32.1	4.4

Remark:

1. Emission Level(dBuV/m) = Raw Value(dBuV) + Correction Factor(dB/m)
2. Correction Factor(dB/m) = Antenna Factor(dB/m) + Cable Factor(dB)
– Pre-Amplifier Factor(dB)
3. The other emission levels were very low against the limit.
4. Margin value = Emission Level – Limit value

4.2 Conducted Emission Measurement

4.2.1 Limits of Conducted Emission Measurement

Frequency (MHz)	Conducted Limit (dBuV)	
	Quasi-peak	Average
0.15 - 0.5	66 - 56	56 - 46
0.50 - 5.0	56	46
5.0 - 30.0	60	50

- Note:** 1. The lower limit shall apply at the transition frequencies.
 2. The limit decreases in line with the logarithm of the frequency in the range of 0.15 to 0.50MHz.

4.2.2 Test Instruments

Description & Manufacturer	Model No.	Serial No.	Cal. Date	Cal. Due
Test Receiver ROHDE & SCHWARZ	ESCI	100613	Nov. 16, 2015	Nov. 15, 2016
RF signal cable (with 10dB PAD) Woken	5D-FB	Cable-cond1-01	Dec. 26, 2015	Dec. 25, 2016
LISN ROHDE & SCHWARZ (EUT)	ESH3-Z5	835239/001	Feb. 26, 2016	Feb. 25, 2017
LISN ROHDE & SCHWARZ (Peripheral)	ESH3-Z5	100311	Jul. 28, 2016	Jul. 27, 2017
Software ADT	BV ADT_Cond_ V7.3.7.3	NA	NA	NA

- Note:** 1. The calibration interval of the above test instruments is 12 months and the calibrations are traceable to NML/ROC and NIST/USA.
 2. The test was performed in HwaYa Shielded Room 1.
 3. The VCCI Site Registration No. is C-2040.

4.2.3 Test Procedures

- The EUT was placed 0.4 meters from the conducting wall of the shielded room with EUT being connected to the power mains through a line impedance stabilization network (LISN). Other support units were connected to the power mains through another LISN. The two LISNs provide 50 ohm/ 50uH of coupling impedance for the measuring instrument.
- Both lines of the power mains connected to the EUT were checked for maximum conducted interference.
- The frequency range from 150kHz to 30MHz was searched. Emission levels under (Limit - 20dB) was not recorded.

Note: The resolution bandwidth and video bandwidth of test receiver is 9kHz for quasi-peak detection (QP) and average detection (AV) at frequency 0.15MHz-30MHz.

4.2.4 Deviation from Test Standard

No deviation.

4.2.5 Test Setup

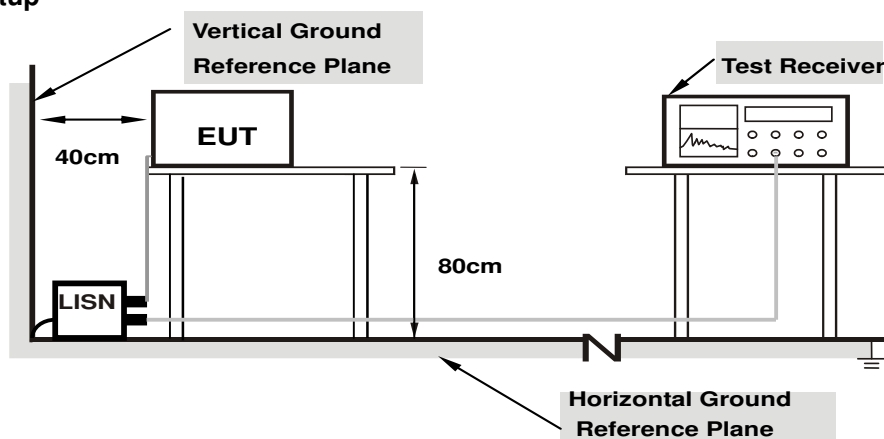

Note: 1.Support units were connected to second LISN.

For the actual test configuration, please refer to the attached file (Test Setup Photo).

4.2.6 EUT Operating Conditions

Same as 4.1.6.

4.2.7 Test Results

Phase	Line (L)	Detector Function	Quasi-Peak (QP) / Average (AV)
-------	----------	-------------------	--------------------------------

No	Freq. [MHz]	Corr. Factor (dB)	Reading Value		Emission Level		Limit		Margin	
			[dB (uV)]		[dB (uV)]		[dB (uV)]		(dB)	
			Q.P.	AV.	Q.P.	AV.	Q.P.	AV.	Q.P.	AV.
1	0.18128	10.02	41.45	35.06	51.47	45.08	64.43	54.43	-12.96	-9.35
2	0.37287	10.11	39.40	31.83	49.51	41.94	58.44	48.44	-8.93	-6.50
3	0.91245	10.19	37.96	31.70	48.15	41.89	56.00	46.00	-7.85	-4.11
4	1.37774	10.23	36.79	30.34	47.02	40.57	56.00	46.00	-8.98	-5.43
5	4.43145	10.43	36.70	34.39	47.13	44.82	56.00	46.00	-8.87	-1.18
6	12.58380	10.88	24.40	17.77	35.28	28.65	60.00	50.00	-24.72	-21.35

Remarks:

1. Q.P. and AV. are abbreviations of quasi-peak and average individually.
2. The emission levels of other frequencies were very low against the limit.
3. Margin value = Emission level - Limit value
4. Correction factor = Insertion loss + Cable loss
5. Emission Level = Correction Factor + Reading Value.

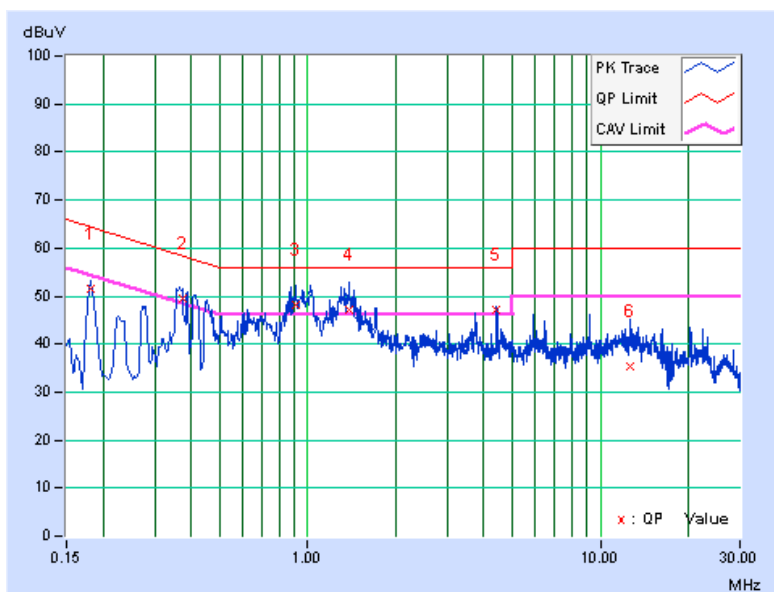

Phase	Neutral (N)	Detector Function	Quasi-Peak (QP) / Average (AV)
-------	-------------	-------------------	--------------------------------

No	Freq. [MHz]	Corr. Factor (dB)	Reading Value [dB (uV)]		Emission Level [dB (uV)]		Limit [dB (uV)]		Margin (dB)	
			Q.P.	AV.	Q.P.	AV.	Q.P.	AV.	Q.P.	AV.
			1	0.18128	10.03	41.34	34.67	51.37	44.70	64.43
2	0.36896	10.12	39.44	34.62	49.56	44.74	58.52	48.52	-8.96	-3.78
3	0.78733	10.18	42.11	35.47	52.29	45.65	56.00	46.00	-3.71	-0.35
4	1.32837	10.23	35.02	28.25	45.25	38.48	56.00	46.00	-10.75	-7.52
5	4.42867	10.46	31.28	28.66	41.74	39.12	56.00	46.00	-14.26	-6.88
6	16.22792	11.20	29.19	25.20	40.39	36.40	60.00	50.00	-19.61	-13.60

Remarks:

1. Q.P. and AV. are abbreviations of quasi-peak and average individually.
2. The emission levels of other frequencies were very low against the limit.
3. Margin value = Emission level - Limit value
4. Correction factor = Insertion loss + Cable loss
5. Emission Level = Correction Factor + Reading Value.

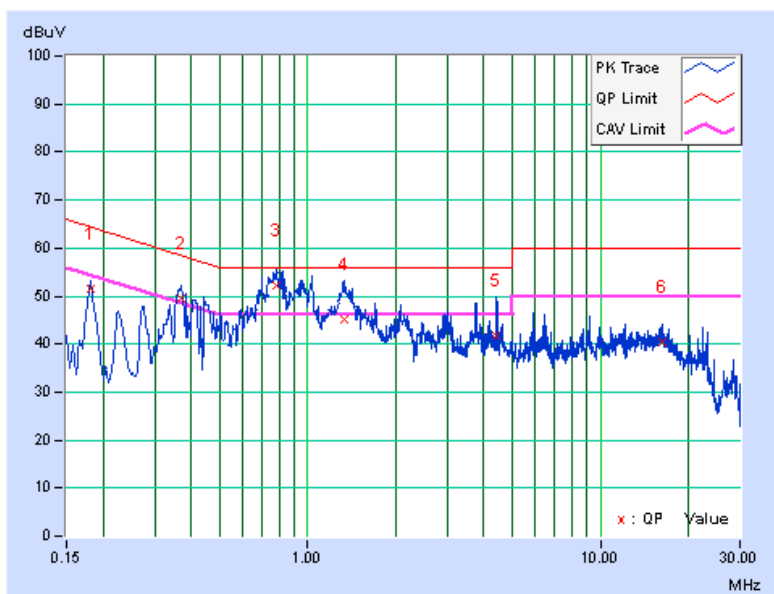

4.3 Transmit Power Measurement

4.3.1 Limits of Transmit Power Measurement

Operation Band	EUT Category		LIMIT
U-NII-1	---	Outdoor Access Point	1 Watt (30 dBm) (Max. e.i.r.p \leq 125mW(21 dBm) at any elevation angle above 30 degrees as measured from the horizon)
	---	Fixed point-to-point Access Point	1 Watt (30 dBm)
	---	Indoor Access Point	1 Watt (30 dBm)
	---	Mobile and Portable client device	250mW (24 dBm)
U-NII-2A	√		250mW (24 dBm) or 11 dBm+10 log B*
U-NII-2C	√		250mW (24 dBm) or 11 dBm+10 log B*
U-NII-3	---		1 Watt (30 dBm)

*B is the 26 dB emission bandwidth in megahertz

Per KDB 662911 Method of conducted output power measurement on IEEE 802.11 devices,

Array Gain = 0 dB (i.e., no array gain) for $N_{ANT} \leq 4$;

Array Gain = 0 dB (i.e., no array gain) for channel widths ≥ 40 MHz for any N_{ANT} ;

Array Gain = $5 \log(N_{ANT}/N_{SS})$ dB or 3 dB, whichever is less for 20-MHz channel widths with $N_{ANT} \geq 5$.

For power measurements on all other devices: Array Gain = $10 \log(N_{ANT}/N_{SS})$ dB.

4.3.2 Test Setup

For 802.11a, 802.11n (HT20), 802.11n (HT40)

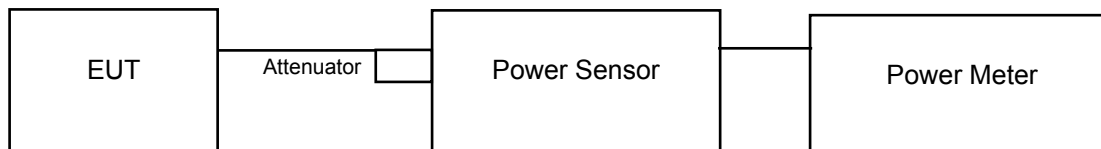

For 802.11ac (VHT80)

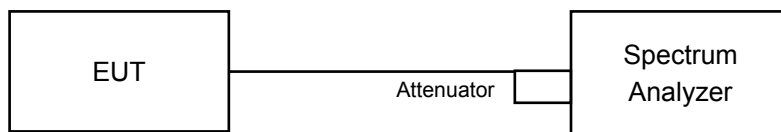

For 26dB and Occupied Bandwidth

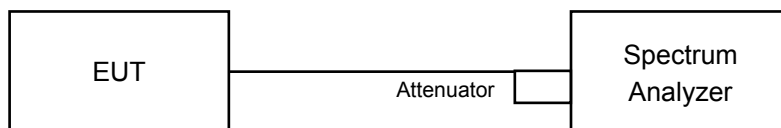

4.3.3 Test Instruments

Refer to section 4.1.2 to get information of above instrument.

4.3.4 Test Procedure

For Average Power Measurement

For 802.11a, 802.11n (HT20), 802.11n (HT40)

Method PM is used to perform output power measurement, trigger and gating function of wide band power meter is enabled to measure max output power of TX on burst. Duty factor is not added to measured value.

For 802.11ac (VHT80)

- a. Set span to encompass the entire 26 dB EBW (or, alternatively, the entire 99% occupied bandwidth) of the signal.
- b. Set sweep trigger to “free run”.
- c. Set RBW = 1 MHz.
- d. Set VBW \geq 3 MHz
- e. Number of points in sweep \geq 2 Span / RBW.
- f. Sweep time \leq (number of points in sweep) * T
- g. Using emission bandwidth to determine the frequency span for integration the channel bandwidth.
- h. Detector = RMS.
- i. Trace mode = max hold.
- j. Allow max hold to run for at least 60 seconds, or longer as needed to allow the trace to stabilize.
- k. Compute power by integrating the spectrum across the EBW (or, alternatively, the entire 99% occupied bandwidth) of the signal using the instrument’s band power measurement function with band limits set equal to the EBW (or occupied bandwidth) band edges. If the instrument does not have a band power function, sum the spectrum levels (in power units) at 1 MHz intervals extending across the EBW (or, alternatively, the entire 99% occupied bandwidth) of the spectrum.

For 26dB Bandwidth

- a. Set RBW = approximately 1% of the emission bandwidth.
- b. Set the VBW > RBW.
- c. Detector = Peak.
- d. Trace mode = max hold.
- e. Measure the maximum width of the emission that is 26 dB down from the peak of the emission. Compare this with the RBW setting of the analyzer. Readjust RBW and repeat measurement as needed until the RBW/EBW ratio is approximately 1%.

4.3.5 Deviation from Test Standard

No deviation.

4.3.6 EUT Operating Conditions

The software provided by client to enable the EUT under transmission condition continuously at lowest, middle and highest channel frequencies individually.

4.3.7 Test Result

Power Output:

802.11a

Chan.	Freq. (MHz)	Maximum Conducted Power (dBm)			Total Power (mW)	Total Power (dBm)	Power Limit (dBm)	Pass / Fail
		Chain 0	Chain 1	Chain 2				
52	5260	16.08	15.74	16.31	120.804	20.82	24.00	Pass
60	5300	16.13	15.86	16.24	121.641	20.85	24.00	Pass
64	5320	15.99	15.63	15.81	114.385	20.58	24.00	Pass
100	5500	15.86	15.52	16.02	114.187	20.58	24.00	Pass
116	5580	15.92	15.53	16.11	115.643	20.63	24.00	Pass
140	5700	15.79	15.86	16.23	118.455	20.74	24.00	Pass

Note:

Chain 0

1. $11\text{dBm} + 10\log (21.43) = 24.31 > 24\text{dBm}$
2. $11\text{dBm} + 10\log (20.80) = 24.18 > 24\text{dBm}$
3. $11\text{dBm} + 10\log (21.65) = 24.35 > 24\text{dBm}$
4. $11\text{dBm} + 10\log (29.21) = 25.66 > 24\text{dBm}$
5. $11\text{dBm} + 10\log (27.19) = 25.34 > 24\text{dBm}$
6. $11\text{dBm} + 10\log (33.32) = 26.23 > 24\text{dBm}$

Chain 1

1. $11\text{dBm} + 10\log (26.31) = 25.20 > 24\text{dBm}$
2. $11\text{dBm} + 10\log (21.16) = 24.26 > 24\text{dBm}$
3. $11\text{dBm} + 10\log (33.17) = 26.21 > 24\text{dBm}$
4. $11\text{dBm} + 10\log (21.60) = 24.34 > 24\text{dBm}$
5. $11\text{dBm} + 10\log (21.72) = 24.37 > 24\text{dBm}$
6. $11\text{dBm} + 10\log (26.78) = 25.28 > 24\text{dBm}$

Chain 2

1. $11\text{dBm} + 10\log (20.47) = 24.11 > 24\text{dBm}$
2. $11\text{dBm} + 10\log (20.52) = 24.12 > 24\text{dBm}$
3. $11\text{dBm} + 10\log (27.18) = 25.34 > 24\text{dBm}$
4. $11\text{dBm} + 10\log (20.57) = 24.13 > 24\text{dBm}$
5. $11\text{dBm} + 10\log (20.39) = 24.09 > 24\text{dBm}$
6. $11\text{dBm} + 10\log (21.87) = 24.40 > 24\text{dBm}$

802.11n (HT20)

Chan.	Freq. (MHz)	Maximum Conducted Power (dBm)			Total Power (mW)	Total Power (dBm)	Power Limit (dBm)	Pass / Fail
		Chain 0	Chain 1	Chain 2				
52	5260	16.43	16.20	16.40	129.293	21.12	24.00	Pass
60	5300	16.76	16.02	16.36	130.669	21.16	24.00	Pass
64	5320	16.44	16.23	16.06	126.396	21.02	24.00	Pass
100	5500	16.56	16.17	16.23	128.666	21.09	24.00	Pass
116	5580	16.33	16.04	16.30	125.791	21.00	24.00	Pass
140	5700	16.25	16.33	16.12	126.050	21.01	24.00	Pass

Note:

Chain 0

1. $11\text{dBm} + 10\log (24.98) = 24.98 > 24\text{dBm}$
2. $11\text{dBm} + 10\log (29.84) = 25.75 > 24\text{dBm}$
3. $11\text{dBm} + 10\log (24.86) = 24.96 > 24\text{dBm}$
4. $11\text{dBm} + 10\log (35.63) = 26.52 > 24\text{dBm}$
5. $11\text{dBm} + 10\log (32.00) = 26.05 > 24\text{dBm}$
6. $11\text{dBm} + 10\log (36.89) = 26.67 > 24\text{dBm}$

Chain 1

1. $11\text{dBm} + 10\log (26.78) = 25.28 > 24\text{dBm}$
2. $11\text{dBm} + 10\log (23.49) = 24.71 > 24\text{dBm}$
3. $11\text{dBm} + 10\log (22.32) = 24.49 > 24\text{dBm}$
4. $11\text{dBm} + 10\log (24.30) = 24.86 > 24\text{dBm}$
5. $11\text{dBm} + 10\log (26.71) = 25.27 > 24\text{dBm}$
6. $11\text{dBm} + 10\log (28.68) = 25.58 > 24\text{dBm}$

Chain 2

1. $11\text{dBm} + 10\log (21.13) = 24.25 > 24\text{dBm}$
2. $11\text{dBm} + 10\log (21.98) = 24.42 > 24\text{dBm}$
3. $11\text{dBm} + 10\log (22.56) = 24.53 > 24\text{dBm}$
4. $11\text{dBm} + 10\log (23.28) = 24.67 > 24\text{dBm}$
5. $11\text{dBm} + 10\log (26.08) = 25.16 > 24\text{dBm}$
6. $11\text{dBm} + 10\log (26.90) = 25.30 > 24\text{dBm}$

802.11n (HT40)

Chan.	Freq. (MHz)	Maximum Conducted Power (dBm)			Total Power (mW)	Total Power (dBm)	Power Limit (dBm)	Pass / Fail
		Chain 0	Chain 1	Chain 2				
54	5270	19.22	18.60	19.27	240.532	23.81	24.00	Pass
62	5310	19.24	18.53	19.53	244.974	23.89	24.00	Pass
102	5510	19.60	18.25	19.56	248.400	23.95	24.00	Pass
110	5550	19.53	18.21	19.71	249.506	23.97	24.00	Pass
134	5670	19.57	18.25	19.66	249.877	23.98	24.00	Pass

Note:

Chain 0

1. $11\text{dBm} + 10\log (91.75) = 30.63 > 24\text{dBm}$
2. $11\text{dBm} + 10\log (94.82) = 30.77 > 24\text{dBm}$
3. $11\text{dBm} + 10\log (95.48) = 30.80 > 24\text{dBm}$
4. $11\text{dBm} + 10\log (94.68) = 30.76 > 24\text{dBm}$
5. $11\text{dBm} + 10\log (96.48) = 30.84 > 24\text{dBm}$

Chain 1

1. $11\text{dBm} + 10\log (91.92) = 30.63 > 24\text{dBm}$
2. $11\text{dBm} + 10\log (93.82) = 30.72 > 24\text{dBm}$
3. $11\text{dBm} + 10\log (79.67) = 30.01 > 24\text{dBm}$
4. $11\text{dBm} + 10\log (86.84) = 30.39 > 24\text{dBm}$
5. $11\text{dBm} + 10\log (90.74) = 30.58 > 24\text{dBm}$

Chain 2

1. $11\text{dBm} + 10\log (77.91) = 29.92 > 24\text{dBm}$
2. $11\text{dBm} + 10\log (61.94) = 28.92 > 24\text{dBm}$
3. $11\text{dBm} + 10\log (77.15) = 29.87 > 24\text{dBm}$
4. $11\text{dBm} + 10\log (85.05) = 30.30 > 24\text{dBm}$
5. $11\text{dBm} + 10\log (79.78) = 30.02 > 24\text{dBm}$

802.11ac (VHT80)

Chan.	Freq. (MHz)	Maximum Conducted Power (dBm)			Total Power (mW)	Total Power (dBm)	Power Limit (dBm)	Pass / Fail
		Chain 0	Chain 1	Chain 2				
58	5290	14.63	14.60	14.85	88.429	19.47	24.00	Pass
106	5530	19.48	18.17	19.58	245.113	23.89	24.00	Pass
122	5610	19.39	18.11	19.46	239.918	23.80	24.00	Pass

Note:

Chain 0

1. $11\text{dBm} + 10\log (84.23) = 30.25 > 24\text{dBm}$
2. $11\text{dBm} + 10\log (176.85) = 33.48 > 24\text{dBm}$
3. $11\text{dBm} + 10\log (83.42) = 30.21 > 24\text{dBm}$

Chain 1

1. $11\text{dBm} + 10\log (83.32) = 30.21 > 24\text{dBm}$
2. $11\text{dBm} + 10\log (143.88) = 32.58 > 24\text{dBm}$
3. $11\text{dBm} + 10\log (82.64) = 30.17 > 24\text{dBm}$

Chain 2

1. $11\text{dBm} + 10\log (82.31) = 30.15 > 24\text{dBm}$
2. $11\text{dBm} + 10\log (136.99) = 32.37 > 24\text{dBm}$
3. $11\text{dBm} + 10\log (82.67) = 30.17 > 24\text{dBm}$

26dB Bandwidth:

802.11a

Chan.	Freq. (MHz)	26dBc Bandwidth (MHz)		
		Chain 0	Chain 1	Chain 2
52	5260	21.43	26.31	20.47
60	5300	20.80	21.16	20.52
64	5320	21.65	33.17	27.18
100	5500	29.21	21.60	20.57
116	5580	27.19	21.72	20.39
140	5700	33.32	26.78	21.87

802.11n (HT20)

Chan.	Freq. (MHz)	26dBc Bandwidth (MHz)		
		Chain 0	Chain 1	Chain 2
52	5260	24.98	26.78	21.13
60	5300	29.84	23.49	21.98
64	5320	24.86	22.32	22.56
100	5500	35.63	24.30	23.28
116	5580	32.00	26.71	26.08
140	5700	36.89	28.68	26.90

802.11n (HT40)

Chan.	Freq. (MHz)	26dBc Bandwidth (MHz)		
		Chain 0	Chain 1	Chain 2
54	5270	91.75	91.92	77.91
62	5310	94.82	93.82	61.94
102	5510	95.48	79.67	77.15
110	5550	94.68	86.84	85.05
134	5670	96.48	90.74	79.78

802.11ac (VHT80)

Chan.	Freq. (MHz)	26dBc Bandwidth (MHz)		
		Chain 0	Chain 1	Chain 2
58	5290	84.23	83.32	82.31
106	5530	176.85	143.88	136.99
122	5610	83.42	82.64	82.67

Spectrum Plot of Worst Value

802.11a

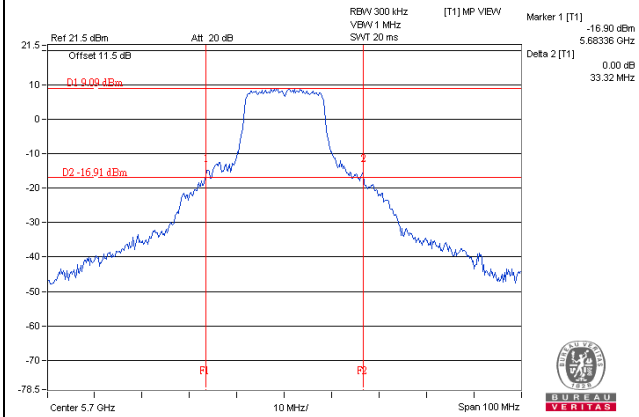

802.11n (HT20)

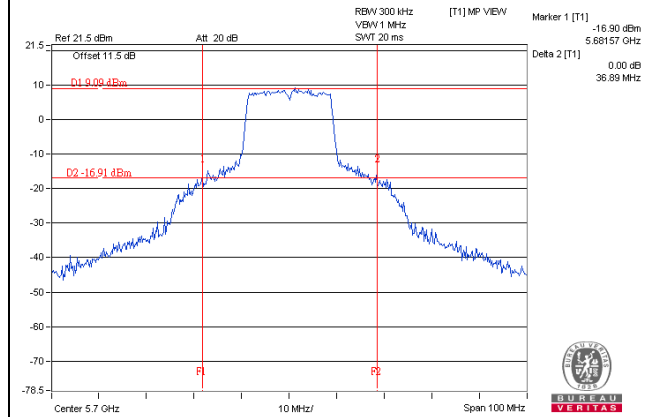

802.11n (HT40)

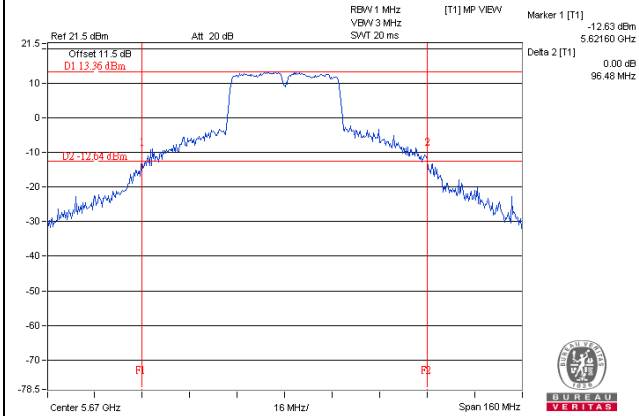

802.11ac (VHT80)

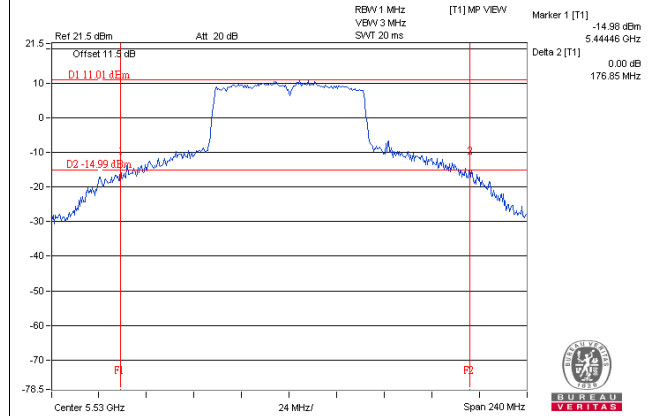

4.4 Occupied Bandwidth Measurement

4.4.1 Test Setup

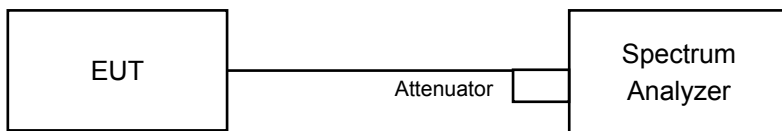

4.4.2 Test Instruments

Refer to section 4.1.2 to get information of above instrument.

4.4.3 Test Procedure

The transmitter output was connected to the spectrum analyzer through an attenuator. The bandwidth of the fundamental frequency was measured by spectrum analyzer with resolution bandwidth in the range of 1% to 5% of the anticipated emission bandwidth, and a video bandwidth at least 3x the resolution bandwidth and set the detector to sample. The width of a frequency band such that, below the lower and above the upper frequency limits, the mean powers emitted are each equal to a specified percentage 0.5 %of the total mean power of a given emission.

4.4.4 Test Result

802.11a

Chan.	Freq. (MHz)	Occupied Bandwidth (MHz)		
		Chain 0	Chain 1	Chain 2
52	5260	17.04	17.04	16.80
60	5300	16.92	16.80	16.80
64	5320	17.04	17.64	17.04
100	5500	17.16	17.04	16.80
116	5580	17.16	17.04	16.92
140	5700	17.64	17.04	17.04

802.11n (HT20)

Chan.	Freq. (MHz)	Occupied Bandwidth (MHz)		
		Chain 0	Chain 1	Chain 2
52	5260	18.12	18.00	18.00
60	5300	18.12	18.00	17.88
64	5320	18.12	17.88	17.88
100	5500	18.12	17.88	17.88
116	5580	18.36	18.00	18.00
140	5700	18.48	18.00	18.00

802.11n (HT40)

Chan.	Freq. (MHz)	Occupied Bandwidth (MHz)		
		Chain 0	Chain 1	Chain 2
54	5270	37.44	37.56	37.20
62	5310	37.68	38.28	36.96
102	5510	38.04	37.20	37.20
110	5550	38.16	37.44	37.32
134	5670	39.60	37.56	37.32

802.11ac (VHT80)

Chan.	Freq. (MHz)	Occupied Bandwidth (MHz)		
		Chain 0	Chain 1	Chain 2
58	5290	75.88	75.88	75.88
106	5530	77.30	76.44	76.44
122	5610	75.84	76.08	76.08

Spectrum Plot of Worst Value

802.11a

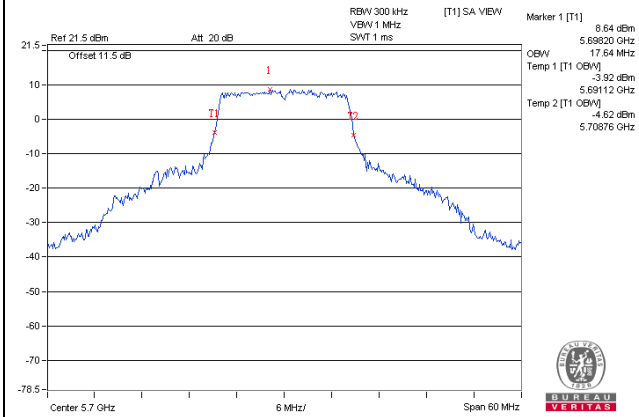

802.11n (HT20)

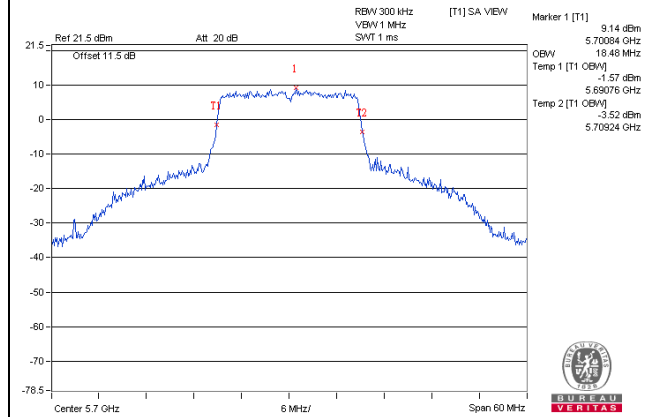

802.11n (HT40)

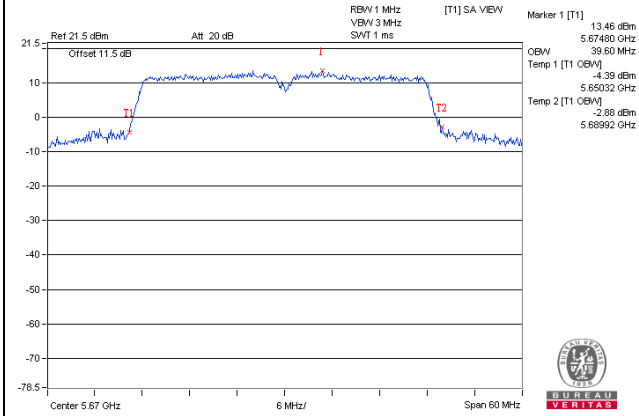

802.11ac (VHT80)

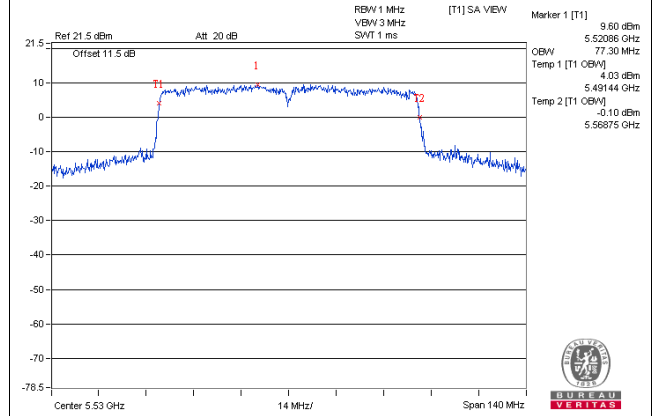

EUT MAXIMUM CONDUCTED POWER

802.11a

Frequency Band (MHz)	Max. Power	
	Output Power (mW)	Output Power (dBm)
5250~5350	121.641	20.85
5470~5725	118.455	20.74

802.11n (HT20)

Frequency Band (MHz)	Max. Power	
	Output Power (mW)	Output Power (dBm)
5250~5350	130.669	21.16
5470~5725	128.666	21.09

802.11n (HT40)

Frequency Band (MHz)	Max. Power	
	Output Power (mW)	Output Power (dBm)
5250~5350	244.974	23.89
5470~5725	249.877	23.98

802.11ac (VHT80)

Frequency Band (MHz)	Max. Power	
	Output Power (mW)	Output Power (dBm)
5250~5350	88.429	19.47
5470~5725	245.113	23.89

4.5 Peak Power Spectral Density Measurement

4.5.1 Limits of Peak Power Spectral Density Measurement

Operation Band	EUT Category		LIMIT
U-NII-1	---	Outdoor Access Point	17dBm/ MHz
	---	Fixed point-to-point Access Point	
	---	Indoor Access Point	
	---	Mobile and Portable client device	11dBm/ MHz
U-NII-2A	√		11dBm/ MHz
U-NII-2C	√		11dBm/ MHz
U-NII-3	---		30dBm/ 500kHz

4.5.2 Test Setup

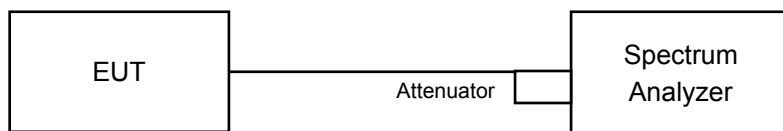

4.5.3 Test Instruments

Refer to section 4.1.2 to get information of above instrument.

4.5.4 Test Procedures

- Set span to encompass the entire emission bandwidth (EBW) of the signal.
- Set RBW = 1 MHz, Set VBW \geq 3 MHz, Detector = RMS
- Sweep time = auto, trigger set to "free run".
- Trace average at least 100 traces in power averaging mode.
- Record the max value and add $10 \log (1/\text{duty cycle})$

4.5.5 Deviation from Test Standard

No deviation.

4.5.6 EUT Operating Conditions

Same as Item 4.3.6.

4.5.7 Test Results

802.11a

Chan.	Freq. (MHz)	PSD w/o Duty Factor (dBm)			Duty Factor (dB)	Total PSD with Duty Factor (dBm)	Max. Limit (dBm)	Pass / Fail
		Chain 0	Chain 1	Chain 2				
52	5260	4.53	3.75	4.38	0.22	9.23	9.43	Pass
60	5300	3.64	3.29	4.02	0.22	8.65	9.43	Pass
64	5320	4.32	4.51	3.31	0.22	9.07	9.43	Pass
100	5500	4.75	2.86	4.18	0.22	8.99	9.43	Pass
116	5580	4.26	3.05	4.12	0.22	8.84	9.43	Pass
140	5700	4.94	3.49	4.60	0.22	9.38	9.43	Pass

Note:

1. Method 1 of power density measurement of KDB 662911 is using for calculating total power density. Total power density is summing entire spectra across corresponding frequency bins on the various outputs by computer.
2. Directional gain = $2.8\text{dBi} + 10\log(3) = 7.57\text{dBi} > 6\text{dBi}$, so the power density limit shall be reduced to $11 - (7.57 - 6) = 9.43\text{dBm}$.
3. Refer to section 3.3 for duty cycle spectrum plot.

802.11n (HT20)

Chan.	Freq. (MHz)	PSD w/o Duty Factor (dBm)			Duty Factor (dB)	Total PSD with Duty Factor (dBm)	Max. Limit (dBm)	Pass / Fail
		Chain 0	Chain 1	Chain 2				
52	5260	3.76	3.46	4.06	0.23	8.77	9.43	Pass
60	5300	3.78	3.49	3.90	0.23	8.73	9.43	Pass
64	5320	3.47	3.22	3.72	0.23	8.47	9.43	Pass
100	5500	4.13	2.74	3.96	0.23	8.65	9.43	Pass
116	5580	4.62	3.29	4.45	0.23	9.16	9.43	Pass
140	5700	4.50	3.13	4.34	0.23	9.03	9.43	Pass

Note:

1. Method 1 of power density measurement of KDB 662911 is using for calculating total power density. Total power density is summing entire spectra across corresponding frequency bins on the various outputs by computer.
2. Directional gain = $2.8\text{dBi} + 10\log(3) = 7.57\text{dBi} > 6\text{dBi}$, so the power density limit shall be reduced to $11 - (7.57 - 6) = 9.43\text{dBm}$.
3. Refer to section 3.3 for duty cycle spectrum plot.

802.11n (HT40)

Chan.	Freq. (MHz)	PSD w/o Duty Factor (dBm)			Duty Factor (dB)	Total PSD with Duty Factor (dBm)	Max. Limit (dBm)	Pass / Fail
		Chain 0	Chain 1	Chain 2				
54	5270	2.92	2.43	2.84	0.47	7.98	9.43	Pass
62	5310	2.93	2.79	2.82	0.47	8.10	9.43	Pass
102	5510	2.52	2.47	2.74	0.47	7.83	9.43	Pass
110	5550	2.22	2.30	2.49	0.47	7.59	9.43	Pass
134	5670	2.08	2.33	2.47	0.47	7.54	9.43	Pass

Note:

1. Method 1 of power density measurement of KDB 662911 is using for calculating total power density. Total power density is summing entire spectra across corresponding frequency bins on the various outputs by computer.
2. Directional gain = $2.8\text{dBi} + 10\log(3) = 7.57\text{dBi} > 6\text{dBi}$, so the power density limit shall be reduced to $11-(7.57-6) = 9.43\text{dBm}$.
3. Refer to section 3.3 for duty cycle spectrum plot.

802.11ac (VHT80)

Chan.	Freq. (MHz)	PSD w/o Duty Factor (dBm)			Duty Factor (dB)	Total PSD with Duty Factor (dBm)	Max. Limit (dBm)	Pass / Fail
		Chain 0	Chain 1	Chain 2				
58	5290	-4.31	-4.85	-4.76	0.48	0.62	9.43	Pass
106	5530	-0.06	-1.79	-0.29	0.48	4.60	9.43	Pass
122	5610	-0.83	-0.65	-0.87	0.48	4.47	9.43	Pass

Note:

1. Method 1 of power density measurement of KDB 662911 is using for calculating total power density. Total power density is summing entire spectra across corresponding frequency bins on the various outputs by computer.
2. Directional gain = $2.8\text{dBi} + 10\log(3) = 7.57\text{dBi} > 6\text{dBi}$, so the power density limit shall be reduced to $11-(7.57-6) = 9.43\text{dBm}$.
3. Refer to section 3.3 for duty cycle spectrum plot.

Spectrum Plot of Worst Value

802.11a / Chain 0 / CH 140

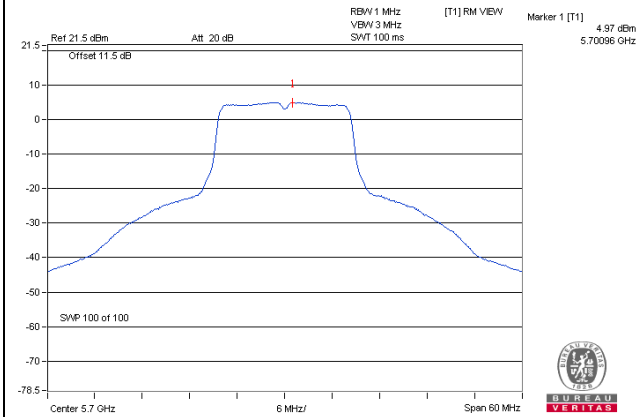

802.11n (HT20) / Chain 0 / CH 116

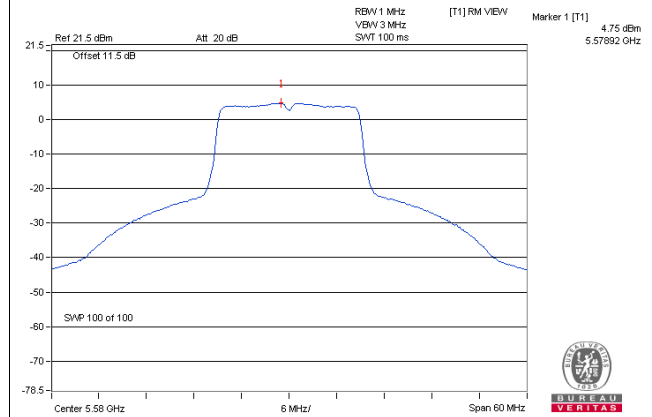

802.11n (HT40) / Chain 0 / CH 62

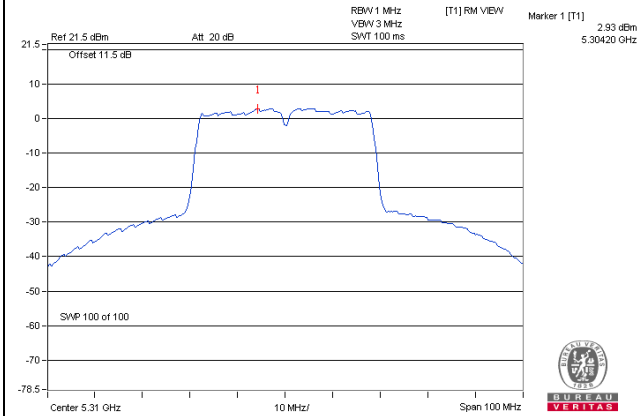

802.11ac (VHT80) / Chain 0 / CH 106

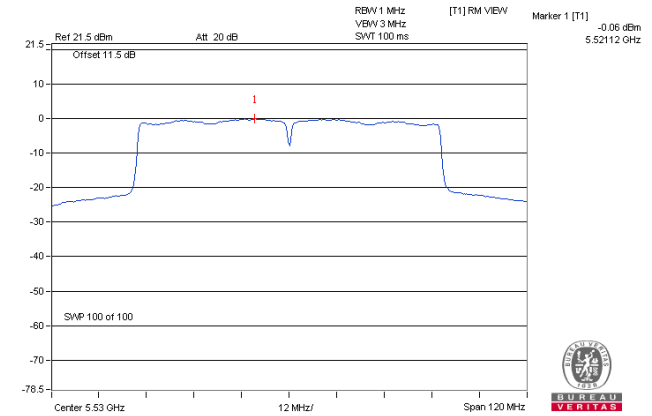

4.6 Frequency Stability

4.6.1 Limits of Frequency Stability Measurement

The frequency of the carrier signal shall be maintained within band of operation

4.6.2 Test Setup

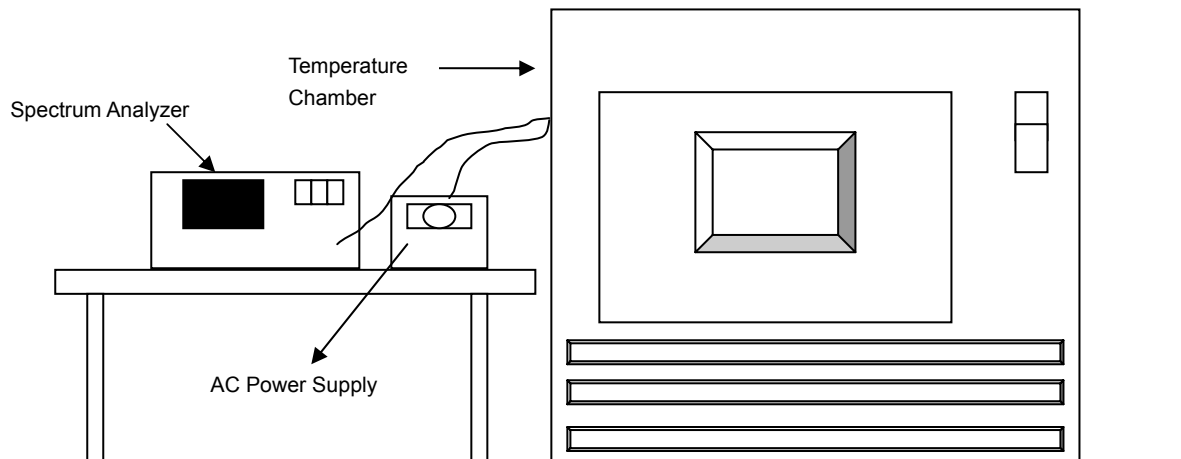

4.6.3 Test Instruments

Refer to section 4.1.2 to get information of above instrument.

4.6.4 Test Procedure

- The EUT was placed inside the environmental test chamber and powered by nominal AC voltage.
- Turn the EUT on and couple its output to a spectrum analyzer.
- Turn the EUT off and set the chamber to the highest temperature specified.
- Allow sufficient time (approximately 30 min) for the temperature of the chamber to stabilize, turn the EUT on and measure the operating frequency after 2, 5, and 10 minutes.
- Repeat step 2 and 3 with the temperature chamber set to the lowest temperature.
- The test chamber was allowed to stabilize at +20 degree C for a minimum of 30 minutes. The supply voltage was then adjusted on the EUT from 85% to 115% and the frequency record.

4.6.5 Deviation from Test Standard

No deviation.

4.6.6 EUT Operating Condition

Set the EUT transmit at un-modulation mode to test frequency stability.

4.6.7 Test Results

Frequency Stability Versus Temp.									
Operating Frequency: 5260MHz									
Temp. (°C)	Power Supply (Vac)	0 Minute		2 Minute		5 Minute		10 Minute	
		Measured Frequency (MHz)	Frequency Drift (%)	Measured Frequency (MHz)	Frequency Drift (%)	Measured Frequency (MHz)	Frequency Drift (%)	Measured Frequency (MHz)	Frequency Drift (%)
50	120	5260.0201	0.00038	5260.018	0.00034	5260.021	0.00040	5260.0205	0.00039
40	120	5259.9761	-0.00045	5259.9783	-0.00041	5259.9758	-0.00046	5259.9758	-0.00046
30	120	5260.0149	0.00028	5260.0117	0.00022	5260.015	0.00029	5260.0147	0.00028
20	120	5260.0204	0.00039	5260.0251	0.00048	5260.0213	0.00040	5260.02	0.00038
10	120	5260.0111	0.00021	5260.0089	0.00017	5260.0098	0.00019	5260.0069	0.00013
0	120	5260.015	0.00029	5260.0169	0.00032	5260.0176	0.00033	5260.0173	0.00033
-10	120	5260.0194	0.00037	5260.02	0.00038	5260.0191	0.00036	5260.0199	0.00038
-20	120	5259.997	-0.00006	5260	0.00000	5259.9995	-0.00001	5259.999	-0.00002
-30	120	5260.0045	0.00009	5260.0075	0.00014	5260.0082	0.00016	5260.0065	0.00012

Frequency Stability Versus Voltage									
Operating Frequency: 5260MHz									
Temp. (°C)	Power Supply (Vac)	0 Minute		2 Minute		5 Minute		10 Minute	
		Measured Frequency (MHz)	Frequency Drift (%)	Measured Frequency (MHz)	Frequency Drift (%)	Measured Frequency (MHz)	Frequency Drift (%)	Measured Frequency (MHz)	Frequency Drift (%)
20	138	5260.0196	0.00037	5260.0245	0.00047	5260.0204	0.00039	5260.0205	0.00039
	120	5260.0204	0.00039	5260.0251	0.00048	5260.0213	0.00040	5260.02	0.00038
	102	5260.0197	0.00037	5260.0244	0.00046	5260.0211	0.00040	5260.0196	0.00037

5 Pictures of Test Arrangements

Please refer to the attached file (Test Setup Photo).

Appendix – Information on the Testing Laboratories

We, Bureau Veritas Consumer Products Services (H.K.) Ltd., Taoyuan Branch, were founded in 1988 to provide our best service in EMC, Radio, Telecom and Safety consultation. Our laboratories are accredited and approved according to ISO/IEC 17025.

If you have any comments, please feel free to contact us at the following:

Linko EMC/RF Lab

Tel: 886-2-26052180

Fax: 886-2-26051924

Hsin Chu EMC/RF/Telecom Lab

Tel: 886-3-6668565

Fax: 886-3-6668323

Hwa Ya EMC/RF/Safety Lab

Tel: 886-3-3183232

Fax: 886-3-3270892

Email: service.adt@tw.bureauveritas.com

Web Site: www.bureauveritas-adt.com

The address and road map of all our labs can be found in our web site also.

--- END ---