

The PISEN logo is displayed in a bold, italicized, black sans-serif font. The word "PISEN" is followed by a registered trademark symbol (®). The logo is centered within a solid yellow rectangular background.

# Welcome Guide

**Bluetooth Headset**

**User Manual**

**EN DE RU ES FR IT**

**Thank you for purchasing the PISEN LE105 Bluetooth headset.**

Wir bedanken uns für Ihren Kauf des PISEN LE105 Bluetooth drahtlosen Kopfhörers.

Благодарим вас за покупку беспроводных наушников PISEN LE105 с функцией Bluetooth.

Gracias por elegir los auriculares inalámbricos con Bluetooth de PISEN LE105.

Merci d'avoir acheté l'écouteur sans fil Bluetooth PISEN LE105.

Grazie per aver acquistato le cuffie wireless Bluetooth PISEN LE105.

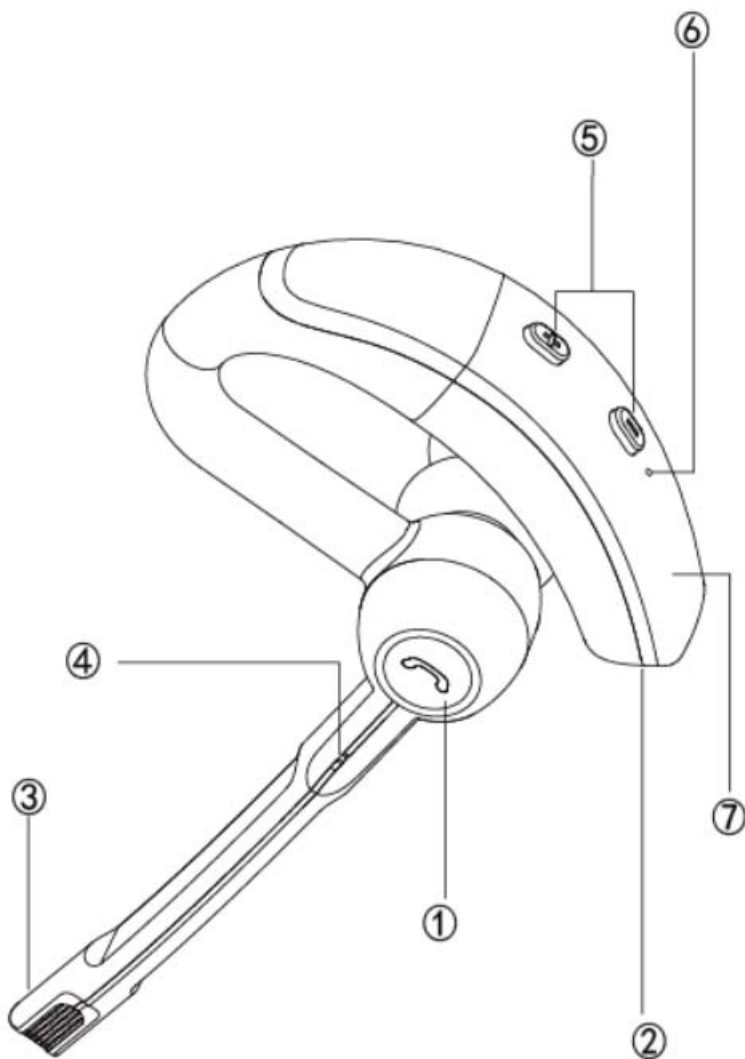

### ① Function Button(Power On/Off/Pause/Play)

Multifunktionstaste( Abspielen/Pause/EIN und AUS )

Многофункциональная кнопка( Включение/выключение/Воспроизведение/пауза)

botón multifunción( encendido / apagado / Reproducir / pausa)

Bouton multi-fonction (Play/Pause/Allumer et éteindre le produit)

Tasto multifunzione (Alimentazione on / off/Riproduzione/pausa)

### ② Charging Micro USB Port

Mikro-USB-Schnittstelle zum Aufladen

Micro USB интерфейс для заряда

Puerto Micro USB para cargar el dispositivo

Interface micro-USB pour recharge

Interfaccia Micro USB per la ricarica

### ③④ Microphone (Phone + Noise reduction)

Mikrofon

Микрофон

Micrófono

Microphone

Microfono

## ⑤ Volume+/Volume-

Leiser Taste / Lauter Taste

Увеличение громкости / Уменьшение громкости

Botón para subir el volumen / Botón para bajar el volumen

Volume + / Volume -

Pulsante Volume su / Tasto di Volume giù

## ⑥ LED Indicator Lights

LED-Anzeige

Светодиодный индикатор

LED

Indicateur LED

Indicatore LED

## ⑦ NFC

# Charging the Battery

Batterie Aufladen | Зарядка батареи | Cómo cargar la batería | Charger la batterie | Ricarica della Batteria

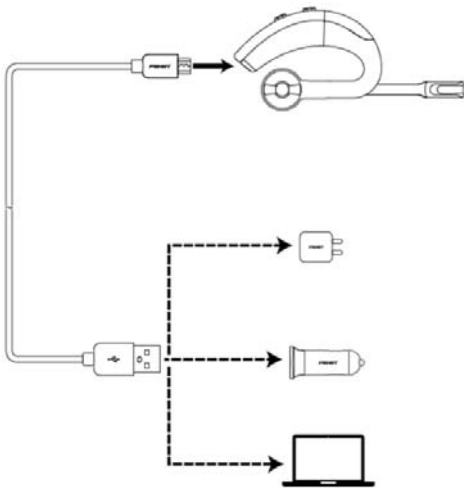

## Attention

- **Store the earphone with power off and in a dry environment.**

- Lagern Sie den Kopfhörer in ausgeschaltetem Zustand und an einem trockenen Ort.
- Храните наушники с отключенным питанием и в сухом месте.
- Guarde los auriculares apagados en un sitio sin humedad.
- Rangez le casque hors tension et dans un environnement sec.
- Riporre le Cuffie spente e in luogo asciutto.

- **If you don't use the earphone for a long period, charging the battery every 2 months for 1-2 hours.**

- Falls Sie den Kopfhörer für längere Zeit nicht benutzen, laden Sie die Batterie alle 2 Monate für 1-2 Stunden.
- Если вы не используете наушники в течение длительного периода, заряжайте аккумулятор каждые 2 месяца в течение 1-2 часов.
- Si no va a utilizar los auriculares durante un periodo largo de tiempo, cargue la batería cada dos meses entre 1 y 2 horas.
- Si vous n'utilisez pas le casque pendant une longue période, charger la batterie tous les 2 mois pendant 1 à 2 heures.
- Se non si usano le cuffie per un lungo periodo di tempo, ricaricare la batteria ogni 2 mesi per 1-2 ore.

- **Please don't twist or bend the earphone. This may cause permanent deformation.**

- Bitte verdrehen oder biegen Sie den Kopfhörer nicht Dies kann ihn dauerhaft beschädigen.
- Пожалуйста, не сгибайте и не сдавливайте наушники.
- No retuerza ni doble los auriculares ya que puede dar lugar a una deformación irreparable.
- Veuillez ne pas tordre ou plier les écouteurs. Cela peut provoquer une déformation permanente.
- Non piegare o torcere le cuffie. La deformazione potrebbe risultare permanente.

# Specifications

<b>Model</b>	LE105
<b>Pairing Name</b>	PISEN-LE105
<b>Bluetooth Version</b>	4.0
<b>Battery Type</b>	75mAh High-density lithium batteries
<b>Charging Port</b>	Micro USB 5V/1A
<b>Support Profile</b>	HFP/A2DP/NFC
<b>Weight</b>	13.2g / 0.47oz
<b>Transmission Range (Hz)</b>	2.402GHz-2.48GHz
<b>Charging Time</b>	About 2 hours
<b>Running Time</b>	Up to 8 hours
<b>Standby time</b>	6-10 days
<b>Operating Temperature</b>	-20°C-60°C
<b>Storage Temperature</b>	-40°C-70°C
<b>FCC ID</b>	<b>2AF56-LE105</b>

# Control Instructions

<b>Function</b>	<b>Operation</b>
Power on	Press and hold the Multi-function button 1.5 seconds.
Power off	Press and hold the Multi-function button 3-4 seconds.
Increase volume	Press the volume up (+) button.
Decrease volume	Press the volume down (-) button.
Answer a call	Press the Multi-function button to answer the call.
End a call	Press the function button during on-line call.
Play media	Press the function button
Pause/restart media playback	Press the function button
Skip to next track	Long press next track (+) button.
Skip to previous track	Long press previous track (-) button.
Pairing mode	Press and hold the function button to enter pairing mode after sounding power on. (LED flashes blue and red alternately when entering the pairing mode.) After turn on the headset, find and connect the Bluetooth device showing as "LE105". If a PIN code is required, enter "0000".
Multipoint Connection	Paired the first phone with the Bluetooth headset, then disable first phone's Bluetooth; paired the headset with second phone, then enable the first phone's Bluetooth, find out the connected Bluetooth headset and finish 1-to-2 connection.
Pair via NFC	Touch the headset with the phone's NFC area. (The NFC function of the phone must be enabled and the screen be unlocked) The headset auto boots and finishes connection. Touch again for 3 second, the headset auto turns OFF.

# Customer Service

## Warranty period

Since the purchase date, this appliance's quality warranty period is 12 months.

## Free service

During warranty period, if there is any breakdown caused due to the product quality, please contact the dealer with this warranty card and purchase proof to get free maintenance.

## Freemaintenance does not apply for the following circumstances:

1. Product label damaged.
2. Damages caused by self-disassembly.
3. The breakdown and artificial mechanical damage caused by water or dropping down.
4. The breakdown and the damage caused by the force majeure.



For FAQs and more help information, please visit:

[PisenGroup.com/support](https://PisenGroup.com/support)



Contact:

[Support@PisenGroup.com](mailto:Support@PisenGroup.com)



@pisenelectronics

Pisen Electronics Co., Limited | Designed by PISEN Made in China



Discover more essentials  
at **PisenGroup.com**

## FCC STATEMENT

This device complies with Part 15 of the FCC rules. Operation is subject to the following two conditions: 1) this device may not cause harmful interference, and 2) this device must accept any interference received, including interference that may cause undesired operation.

Changes or modifications not expressly approved by the party responsible for compliance could void your authority to operate the equipment.

NOTE: This equipment has been tested and found to comply with the limits for a Class B digital device, pursuant to Part 15 of the FCC Rules. These limits are designed to provide reasonable protection against harmful interference in a residential installation.

This equipment generates uses and can radiate radio frequency energy and, if not installed and used in accordance with the instructions, may cause harmful interference to radio communications. However, there is no guarantee that interference will not occur in a particular installation. If this equipment does cause harmful interference to radio or television reception, which can be determined by turning the equipment off and on, the user is encouraged to try to correct the interference by one or more of the following measures:

Reorient or relocate the receiving antenna.

Increase the separation between the equipment and receiver.

Connect the equipment into an outlet on a circuit different from that to which the receiver is connected.

Consult the dealer or an experienced radio/TV technician for help.

