

TEST REPORT

of

FCC Part 15 Subpart C §15.247

FCC ID: 2AF4XAPPBOT-LINK

Equipment Under Test : HOME CAMERA
Model Name : APPBOT-LINK
Applicant : VARRAM SYSTEM Co., Ltd.
Manufacturer : VARRAM SYSTEM Co., Ltd.
Date of Test(s) : 2015. 10. 13 ~ 2015. 10. 21
Date of Issue : 2015. 10. 22

In the configuration tested, the EUT complied with the standards specified above.

Tested By:



Patrick Kang

Date:

2015. 10. 22

Approved By:



Hyunchoe You

Date:

2015. 10. 22

The results shown in this test report refer only to the sample(s) tested unless otherwise stated. This test report cannot be reproduced, except in full, without prior written permission of the Company.

SGS Korea Co., Ltd. (Gunpo Laboratory) 4, LS-ro 182beon-gil, Gunpo-si, Gyeonggi-do, Korea, 15807 <http://www.sgsgroup.kr>

RTT5041-20(2015.10.01)(3)

Tel. +82 31 428 5700 / Fax. +82 31 427 2370

A4(210mm x 297mm)

INDEX

Table of contents

1. General information -----	3
2. Transmitter radiated spurious emissions -----	6
3. Transmitter AC Power Line Conducted Emission-----	20

The results shown in this test report refer only to the sample(s) tested unless otherwise stated. This test report cannot be reproduced, except in full, without prior written permission of the Company.

SGS Korea Co., Ltd. (Gunpo Laboratory) 4, LS-ro 182beon-gil, Gunpo-si, Gyeonggi-do, Korea, 15807 <http://www.sgsgroup.kr>

1. General Information

1.1. Testing Laboratory

SGS Korea Co., Ltd. (Gunpo Laboratory)

- Wireless Div. 2FL, 10-2, LS-ro 182beon-gil, Gunpo-si, Gyeonggi-do, Korea, 15807

All SGS services are rendered in accordance with the applicable SGS conditions of service available on request and accessible at <http://www.sgs.com/en/Terms-and-Conditions.aspx>.

Phone No. : + 82 31 688 0901

Fax No. : + 82 31 688 0921

1.2. Details of Applicant

Applicant : VARRAM SYSTEM Co., Ltd.

Address : RM205, Venture town, 105, shinildong-ro, Daedeok-gu, Daejeon-si, Republic of Korea

Contact Person : Jung, Ju-Yong

Phone No. : + 82 70 8797 8922

1.3. Description of EUT

Kind of Product	HOME CAMERA
Model Name	APPBOT-LINK
Approved Module Name	FN-8126EU (FCC ID: 2AATLFN-8126EU)
Power Supply	DC 3.7 V (Used by rechargeable battery)
Frequency Range	2 412 MHz ~ 2 462 MHz (11b/g/n_HT20), 2 422 MHz ~ 2 452 MHz (11n_HT40)
Modulation Technique	DSSS, OFDM
Number of Channels	11 channels (11b/g/n_HT20), 7 channels (11n_HT40),
Antenna Type	Internal Type
Antenna Gain	0 dBi

1.4. Declaration by the manufacturer

-N/A

The results shown in this test report refer only to the sample(s) tested unless otherwise stated. This test report cannot be reproduced, except in full, without prior written permission of the Company.

SGS Korea Co., Ltd. (Gunpo Laboratory) 4, LS-ro 182beon-gil, Gunpo-si, Gyeonggi-do, Korea, 15807 <http://www.sgsgroup.kr>

1.5. Test Equipment List

Equipment	Manufacturer	Model	S/N	Cal Date	Cal Interval	Cal Due.
Signal Generator	Agilent	E8257D	MY51501169	Jul. 13, 2015	Annual	Jul. 13, 2016
Spectrum Analyzer	Agilent	N9030A	MY53120526	Jun. 23, 2015	Annual	Jun. 23, 2016
High Pass Filter	Wainwright	WHK3.0/18G-10SS	344	Jun. 08, 2015	Annual	Jun. 08, 2016
High Pass Filter	Wainwright	WHNX7.5/26.5G-6SS	15	Jun. 23, 2015	Annual	Jun. 23, 2016
Low Pass Filter	Mini circuits	NLP-1200+	V 8979400903-2	Mar. 12, 2015	Annual	Mar. 12, 2016
Antenna Master	INN-CO	MM4000	N/A	N.C.R.	N/A	N.C.R.
Turn Table	INN-CO	DS 1200S	N/A	N.C.R.	N/A	N.C.R.
Anechoic Chamber	SY Corporation	L x W x H (9.6 m x 6.4 m x 6.6 m)	N/A	N.C.R.	N/A	N.C.R.
Shield Room	SY Corporation	L x W x H (6.5 m x 3.5 m x 3.5 m)	N/A	N.C.R.	N/A	N.C.R.
Preamplifier	H.P.	8447F	2944A03909	Aug. 27, 2015	Annual	Aug. 27, 2016
Preamplifier	R&S	SCU 18	10117	Apr. 10, 2015	Annual	Apr. 10, 2016
Preamplifier	MITEQ Inc.	JS44-18004000-35-8P	1546891	May 07, 2015	Annual	May 07, 2016
Bilog Antenna	SCHWARZBECK MESSELEKTRONIK	VULB9163	396	Jun. 18, 2015	Biennial	Jun. 18, 2017
Loop Antenna	SCHWARZBECK MESSELEKTRONIK	FMZB 1519	1519-039	Aug. 19, 2015	Biennial	Aug. 19, 2017
Horn Antenna	R&S	HF906	100326	Dec. 10, 2013	Biennial	Dec. 10, 2015
Horn Antenna	SCHWARZBECK MESSELEKTRONIK	BBHA9170	BBHA9170431	May. 15, 2014	Biennial	May. 15, 2016
Test Receiver	R&S	ESU26	100109	Mar. 03, 2015	Annual	Mar. 03, 2016
Test Receiver	R&S	ESCI 7	100911	Dec. 24, 2014	Annual	Dec. 24, 2015
Two-Line V-Network	R&S	ENV216	100190	Dec. 25, 2014	Annual	Dec. 25, 2015

► Support equipment

Description	Manufacturer	Model	Serial Number
N/A	-	-	-

The results shown in this test report refer only to the sample(s) tested unless otherwise stated. This test report cannot be reproduced, except in full, without prior written permission of the Company.

SGS Korea Co., Ltd. (Gunpo Laboratory) 4, LS-ro 182beon-gil, Gunpo-si, Gyeonggi-do, Korea, 15807 <http://www.sgsgroup.kr>

1.6. Summary of Test Results

The EUT has been tested according to the following specifications:

APPLIED STANDARD: FCC Part15 Subpart C		
Standard section	Test Item(s)	Result
15.205 15.209 15.247(d)	Transmitter Radiated Spurious Emissions	Complied
15.207	Transmitter AC Power Line Conducted Emission	Complied

1.7. Test Procedure(s)

The measurement procedures described in the American National Standard for Methods of Measurement of Radio-Noise Emission from Low-Voltage Electrical and Electronic Equipment in the Range of 9 kHz to 40 GHz (ANSI C63.4-2009) and the guidance provided in KDB 558074_v03r03 were used in the measurement of the DUT.

1.8. Sample calculation

Where relevant, the following sample calculation is provided:

1.8.1. Radiation test

Field strength level (dB μ V/m) = Measured level (dB μ V) + Antenna factor (dB) + Cable loss (dB) - amplifier gain(dB)

1.9. Test report revision

Revision	Report number	Date of Issue	Description
0	F690501/RF-RTL009200	2015.10.22	Initial

The results shown in this test report refer only to the sample(s) tested unless otherwise stated. This test report cannot be reproduced, except in full, without prior written permission of the Company.

SGS Korea Co., Ltd. (Gunpo Laboratory) 4, LS-ro 182beon-gil, Gunpo-si, Gyeonggi-do, Korea, 15807 <http://www.sgsgroup.kr>

2. Transmitter Radiated Spurious Emissions and Conducted Spurious Emission

2.1. Test Setup

2.1.1. Transmitter Radiated Spurious Emissions

The diagram below shows the test setup that is utilized to make the measurements for emission from 9 kHz to 30 MHz Emissions.

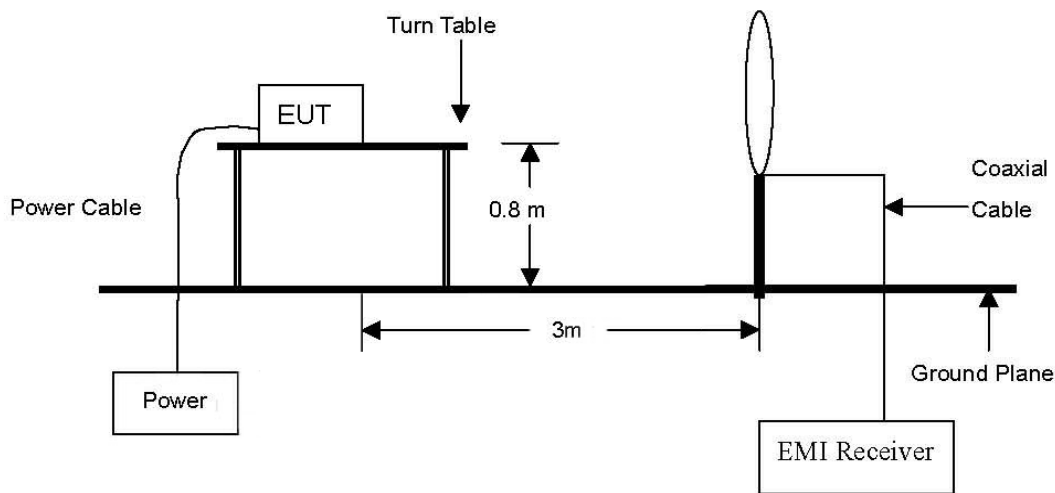

The diagram below shows the test setup that is utilized to make the measurements for emission from 30 MHz to 1 GHz Emissions.

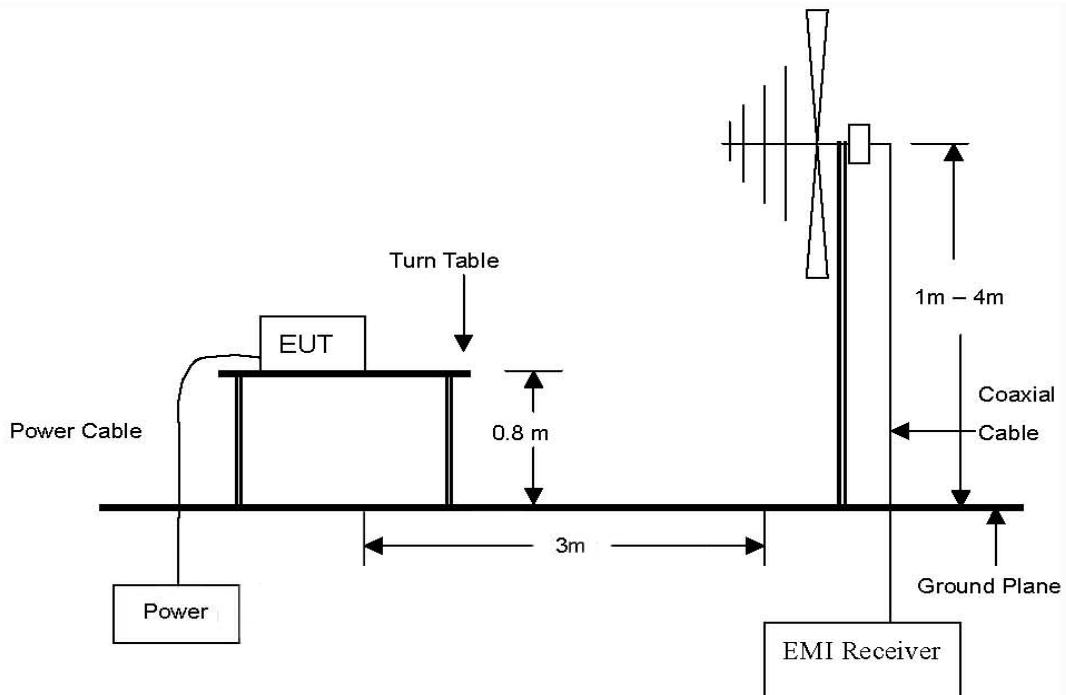

The results shown in this test report refer only to the sample(s) tested unless otherwise stated. This test report cannot be reproduced, except in full, without prior written permission of the Company.

The diagram below shows the test setup that is utilized to make the measurements for emission. The spurious emissions were investigated from 1 GHz to the 10th harmonic of the highest fundamental frequency or 40 GHz, whichever is lower.

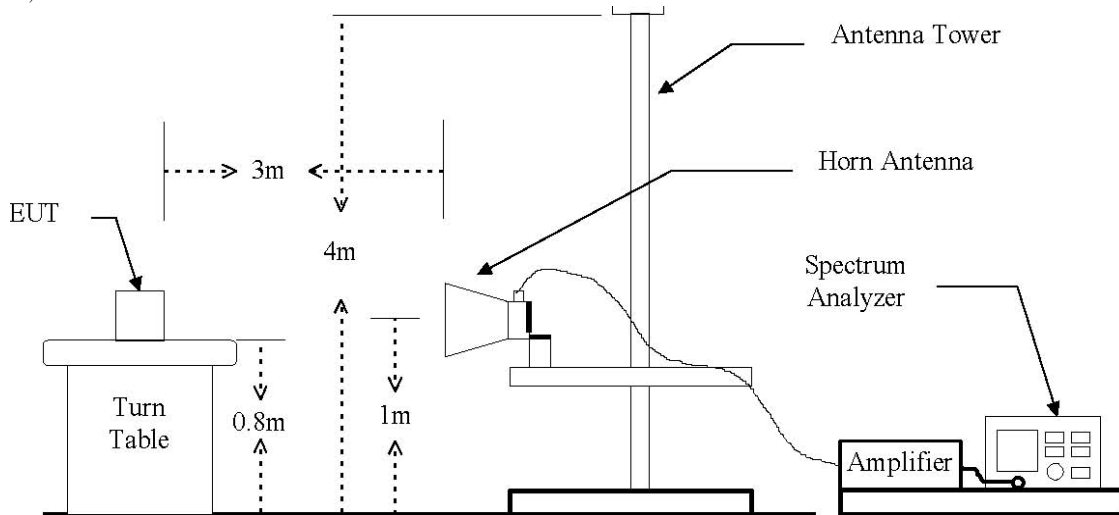

The results shown in this test report refer only to the sample(s) tested unless otherwise stated. This test report cannot be reproduced, except in full, without prior written permission of the Company.

2.2. Limit

According to §15.247(d), in any 100 kHz bandwidth outside the frequency band in which the spread spectrum or digitally modulated intentional radiator is operating, the radio frequency power that is produced by the intentional radiator shall be at least 20 dB below that in the 100 kHz bandwidth within the band that contains the highest level of the desired power, based on either an RF conducted or a radiated measurement, provided the transmitter demonstrates compliance with the peak conducted power limits. If the transmitter complies with the conducted power limits based on the use of RMS averaging over a time interval, as permitted under paragraph(b)(3) of this section, the attenuation required under this paragraph shall be 30 dB instead of 20 dB. Attenuation below the general limits specified in section §15.209(a) is not required. In addition, radiated emission which fall in the restricted band, as define in section §15.205(a), must also comply the radiated emission limits specified in section §15.209(a) (see section §15.205(c))

According to § 15.209(a), Except as provided elsewhere in this Subpart, the emissions from an intentional radiator shall not exceed the field strength levels specified in the following table :

Frequency (MHz)	Distance (Meters)	Field Strength (dB μ V/m)	Field Strength (μ V/m)
0.009 – 0.490	300	20 log (2 400/F(kHz))	2 400/F(kHz)
0.490 – 1.705	30	20 log (24 000/F(kHz))	24 000/F(kHz)
1.705 – 30.0	30	29.54	30
30 - 88	3	40.0	100
88 – 216	3	43.5	150
216 – 960	3	46.0	200
Above 960	3	54.0	500

The results shown in this test report refer only to the sample(s) tested unless otherwise stated. This test report cannot be reproduced, except in full, without prior written permission of the Company.

SGS Korea Co., Ltd. (Gunpo Laboratory) 4, LS-ro 182beon-gil, Gunpo-si, Gyeonggi-do, Korea, 15807 <http://www.sgsgroup.kr>

2.3. Test Procedures

Radiated emissions from the EUT were measured according to the dictates in section 11.0 & 12.0 of KDB 558074_v03r03 and ANSI C63.4-2009.

2.3.1. Test Procedures for emission below 30 MHz

1. The EUT was placed on the top of a rotating table 0.8 meters above the ground at a 3 meter anechoic chamber test site. The table was rotated 360 degrees to determine the position of the highest radiation.
2. Then antenna is a loop antenna is fixed at one meter above the ground to determine the maximum value of the field strength. Both parallel and perpendicular of the antenna are set to make the measurement.
3. For each suspected emission, the EUT was arranged to its worst case and then the table was turned from 0 degrees to 360 degrees to find the maximum reading.
4. The test-receiver system was set to average or quasi peak detect function and Specified Bandwidth with Maximum Hold Mode.

2.3.2. Test Procedures for emission from above 30 MHz

1. The EUT was placed on the top of a rotating table 0.8 meters above the ground at a 3 meter anechoic chamber test site. The table was rotated 360 degrees to determine the position of the highest radiation.
2. During performing radiated emission below 1 GHz, the EUT was set 3 meters away from the interference receiving antenna, which was mounted on the top of a variable-height antenna tower. During performing radiated emission above 1 GHz, the EUT was set 3 meter away from the interference-receiving antenna.
3. The antenna is a bi-log antenna, a horn antenna and its height is varied from one meter to four meters above the ground to determine the maximum value of the field strength. Both horizontal and vertical polarizations of the antenna are set to make the measurement.
4. For each suspected emission, the EUT was arranged to its worst case and then the antenna was tuned to heights from 1 meter to 4 meters and the table was turned from 0 degrees to 360 degrees to find the maximum reading.
5. The test-receiver system was set to Peak Detect Function and Specified Bandwidth with Maximum Hold Mode.
6. If the emission level of the EUT in peak mode was 10 dB lower than the limit specified, then testing could be stopped and the peak values of the EUT would be reported. Otherwise the emissions that did not have 10 dB margin would be re-tested one by one using peak, quasi-peak or average method as specified and then reported in a data sheet.

The results shown in this test report refer only to the sample(s) tested unless otherwise stated. This test report cannot be reproduced, except in full, without prior written permission of the Company.

SGS Korea Co., Ltd. (Gunpo Laboratory) 4, LS-ro 182beon-gil, Gunpo-si, Gyeonggi-do, Korea, 15807 <http://www.sgsgroup.kr>

NOTE;

All data rates and modes were investigated for radiated spurious emissions. Only the radiated emissions of the configuration that produced the worst case emissions are reported in this section.

1. Unwanted Emissions into Non-Restricted Frequency Bands

- The Reference Level Measurement refer to section 11.2

Set analyzer center frequency to DTS channel center frequency, SPAN ≥ 1.5 times the DTS bandwidth, the RBW = 100 kHz and VBW $\geq 3 \times$ RBW, Detector = Peak, Sweep time = Auto couple, Trace = Max hold.

- Unwanted Emissions Level Measurement refer to section 11.3

Set the center frequency and span to encompass frequency range to be measured, the RBW = 100 kHz and VBW $\geq 3 \times$ RBW, Detector = Peak, Sweep time = Auto couple, Trace = Max hold.

2. Unwanted Emissions into Restricted Frequency Bands

- Peak Power measurement procedure refer to section 12.2.4

Set RBW = as specified in Table 1, VBW $\geq 3 \times$ RBW, Detector = Peak, Sweep time = auto, Trace = Max hold.

Table 1- RBW as a function of frequency

Frequency	RBW
9 – 150 kHz	200 – 300 Hz
0.15 – 30 MHz	9 – 10 kHz
30 – 1 000 MHz	100 – 120 kHz
>1 000 MHz	1 MHz

- Average Power measurements procedure refer to section 12.2.5.1.

Set RBW = 1 MHz, VBW $\geq 3 \times$ RBW, Detector = RMS, if span/(# of points in sweep) \leq (RBW/2).

Satisfying this condition may require increasing the number of points in the sweep or reducing the span. If this condition cannot be satisfied, then the detector mode shall be set to peak.

Averaging type = power(i.e., RMS). Sweep time = auto, Perform a trace average of at least 100 traces.

3. Test orthogonal plan of EUT is X-axis during radiation test.

The results shown in this test report refer only to the sample(s) tested unless otherwise stated. This test report cannot be reproduced, except in full, without prior written permission of the Company.

2.4. Test Results

Ambient temperature : (24 ± 1) °C
 Relative humidity : 47 % R.H.

2.4.1. Radiated Spurious Emission

The frequency spectrum from 32.768 kHz to 1 000 MHz was investigated. All reading values are applied for peak values per frequency band.

Radiated Emissions			Ant.	Correction Factors		Total	FCC Limit	
Frequency (MHz)	Reading (dBμV)	Detect Mode	Pol.	AF (dB/m)	AMP + CL (dB)	Actual (dBμV/m)	Limit (dBμV/m)	Margin (dB)
65.37	42.70	Peak	H	12.19	-26.46	28.43	40.00	11.57
67.14	52.60	Peak	V	11.02	-26.42	37.20	40.00	2.80
191.99	50.60	Peak	H	11.07	-24.74	36.93	43.50	6.57
192.03	51.80	Peak	V	10.59	-24.74	37.65	43.50	5.85
237.14	49.40	Peak	V	13.41	-24.51	38.30	46.00	7.70
384.01	45.40	Peak	V	16.65	-23.94	38.11	46.00	7.89
448.03	46.90	Peak	V	17.27	-24.55	39.62	46.00	6.38
576.03	47.00	Peak	V	19.02	-23.97	42.05	46.00	3.95
704.07	44.70	Peak	H	20.37	-23.91	41.16	46.00	4.84
Above 800.00	Not detected	-	-	-	-	-	-	-

Remark:

- Spurious emissions for all channels and modes were investigated and almost the same below 1 GHz.
- Reported spurious emissions are in **11b / 1 Mbps / High channel** as worst case among other modes.
- Radiated spurious emission measurement as below
(Actual = Reading + AF + AMP + CL)
- The device has a reference clock operating 32.768 kHz.
- According to § 15.31(o), Emission levels are not reported much lower than the limits by over 20 dB.

The results shown in this test report refer only to the sample(s) tested unless otherwise stated. This test report cannot be reproduced, except in full, without prior written permission of the Company.

SGS Korea Co., Ltd. (Gunpo Laboratory) 4, LS-ro 182beon-gil, Gunpo-si, Gyeonggi-do, Korea, 15807 <http://www.sgsgroup.kr>

2.4.2. Spurious Radiated Emission

The frequency spectrum above 1 000 MHz was investigated.

DSSS: 802.11b

Low Channel (2 412 MHz)

Radiated Emissions			Ant.	Correction Factors		Total	FCC Limit	
Frequency (MHz)	Reading (dB μ V)	Detect Mode	Pol.	AF (dB/m)	CL (dB)	Actual (dB μ V/m)	Limit (dB μ V/m)	Margin (dB)
*2 310.00	19.98	Peak	H	27.77	10.86	58.61	74.00	15.39
*2 310.00	9.89	Average	H	27.77	10.86	48.52	54.00	5.48
*2 385.76	21.05	Peak	H	28.11	9.88	59.04	74.00	14.96
*2 385.76	11.10	Average	H	28.11	9.88	49.09	54.00	4.91
*2 390.00	20.66	Peak	H	28.08	9.86	58.60	74.00	15.40
*2 390.00	10.77	Average	H	28.08	9.86	48.71	54.00	5.29

Radiated Emissions			Ant.	Correction Factors		Total	FCC Limit	
Frequency (MHz)	Reading (dB μ V)	Detect Mode	Pol.	AF (dB/m)	AMP+CL (dB)	Actual (dB μ V/m)	Limit (dB μ V/m)	Margin (dB)
*4 824.25	36.69	Peak	V	32.78	-29.00	40.47	74.00	33.53
*4 824.25	34.60	Average	V	32.78	-29.00	38.38	54.00	15.62
Above 4 900.00	Not detected	-	-	-	-	-	-	-

The results shown in this test report refer only to the sample(s) tested unless otherwise stated. This test report cannot be reproduced, except in full, without prior written permission of the Company.

SGS Korea Co., Ltd. (Gunpo Laboratory) 4, LS-ro 182beon-gil, Gunpo-si, Gyeonggi-do, Korea, 15807 <http://www.sgsgroup.kr>

Middle Channel (2 437 MHz)

Radiated Emissions			Ant.	Correction Factors		Total	FCC Limit	
Frequency (MHz)	Reading (dB μ V)	Detect Mode	Pol.	AF (dB/m)	AMP+CL (dB)	Actual (dB μ V/m)	Limit (dB μ V/m)	Margin (dB)
*4 874.18	40.01	Peak	V	33.01	-28.02	45.00	74.00	29.00
*4 874.18	34.86	Average	V	33.01	-28.02	39.85	54.00	14.15
Above 4 900.00	Not detected	-	-	-	-	-	-	-

High Channel (2 462 MHz)

Radiated Emissions			Ant.	Correction Factors		Total	FCC Limit	
Frequency (MHz)	Reading (dB μ V)	Detect Mode	Pol.	AF (dB/m)	CL (dB)	Actual (dB μ V/m)	Limit (dB μ V/m)	Margin (dB)
*2 483.50	20.04	Peak	H	28.17	9.65	57.86	74.00	16.14
*2 483.50	10.62	Average	H	28.17	9.65	48.44	54.00	5.56
*2 485.96	20.45	Peak	H	28.20	9.68	58.33	74.00	15.67
*2 485.96	10.34	Average	H	28.20	9.68	48.22	54.00	5.78
*2 500.00	20.54	Peak	H	28.31	11.54	60.39	74.00	13.61
*2 500.00	10.00	Average	H	28.31	11.54	49.85	54.00	4.15

Radiated Emissions			Ant.	Correction Factors		Total	FCC Limit	
Frequency (MHz)	Reading (dB μ V)	Detect Mode	Pol.	AF (dB/m)	AMP+CL (dB)	Actual (dB μ V/m)	Limit (dB μ V/m)	Margin (dB)
*4 923.96	41.13	Peak	V	33.12	-28.98	45.27	74.00	28.73
*4 923.96	36.84	Average	V	33.12	-28.98	40.98	54.00	13.02
Above 5 000.00	Not detected	-	-	-	-	-	-	-

The results shown in this test report refer only to the sample(s) tested unless otherwise stated. This test report cannot be reproduced, except in full, without prior written permission of the Company.

SGS Korea Co., Ltd. (Gunpo Laboratory) 4, LS-ro 182beon-gil, Gunpo-si, Gyeonggi-do, Korea, 15807 <http://www.sgsgroup.kr>

OFDM: 802.11g

Low Channel (2 412 MHz)

Radiated Emissions			Ant.	Correction Factors		Total	FCC Limit	
Frequency (MHz)	Reading (dB μ V)	Detect Mode	Pol.	AF (dB/m)	CL (dB)	Actual (dB μ V/m)	Limit (dB μ V/m)	Margin (dB)
*2 310.00	19.99	Peak	H	27.77	10.86	58.62	74.00	15.38
*2 310.00	9.96	Average	H	27.77	10.86	48.59	54.00	5.41
*2 385.52	20.61	Peak	H	28.11	9.88	58.60	74.00	15.40
*2 385.52	10.08	Average	H	28.11	9.88	48.07	54.00	5.93
*2 390.00	19.52	Peak	H	28.08	9.86	57.46	74.00	16.54
*2 390.00	9.50	Average	H	28.08	9.86	47.44	54.00	6.56

Radiated Emissions			Ant.	Correction Factors		Total	FCC Limit	
Frequency (MHz)	Reading (dB μ V)	Detect Mode	Pol.	AF (dB/m)	AMP+CL (dB)	Actual (dB μ V/m)	Limit (dB μ V/m)	Margin (dB)
*4 824.17	40.12	Peak	V	32.78	-29.00	43.90	74.00	30.10
*4 824.17	32.44	Average	V	32.78	-29.00	36.22	54.00	17.78
Above 4 900.00	Not detected	-	-	-	-	-	-	-

Middle Channel (2 437 MHz)

Radiated Emissions			Ant.	Correction Factors		Total	FCC Limit	
Frequency (MHz)	Reading (dB μ V)	Detect Mode	Pol.	AF (dB/m)	AMP+CL (dB)	Actual (dB μ V/m)	Limit (dB μ V/m)	Margin (dB)
*4 873.90	39.37	Peak	V	33.01	-28.02	44.36	74.00	29.64
*4 873.90	33.42	Average	V	33.01	-28.02	38.41	54.00	15.59
Above 4 900.00	Not detected	-	-	-	-	-	-	-

The results shown in this test report refer only to the sample(s) tested unless otherwise stated. This test report cannot be reproduced, except in full, without prior written permission of the Company.

SGS Korea Co., Ltd. (Gunpo Laboratory) 4, LS-ro 182beon-gil, Gunpo-si, Gyeonggi-do, Korea, 15807 <http://www.sgsgroup.kr>

High Channel (2 462 MHz)

Radiated Emissions			Ant.	Correction Factors		Total	FCC Limit	
Frequency (MHz)	Reading (dB μ V)	Detect Mode	Pol.	AF (dB/m)	CL (dB)	Actual (dB μ V/m)	Limit (dB μ V/m)	Margin (dB)
*2 483.50	20.94	Peak	H	28.17	9.65	58.76	74.00	15.24
*2 483.50	11.48	Average	H	28.17	9.65	49.30	54.00	4.70
*2 484.44	21.94	Peak	H	28.18	9.66	59.78	74.00	14.22
*2 484.44	11.25	Average	H	28.18	9.66	49.09	54.00	4.91
*2 500.00	20.44	Peak	H	28.31	11.54	60.29	74.00	13.71
*2 500.00	10.70	Average	H	28.31	11.54	50.55	54.00	3.45

Radiated Emissions			Ant.	Correction Factors		Total	FCC Limit	
Frequency (MHz)	Reading (dB μ V)	Detect Mode	Pol.	AF (dB/m)	AMP+CL (dB)	Actual (dB μ V/m)	Limit (dB μ V/m)	Margin (dB)
*4 924.00	38.46	Peak	V	33.12	-28.98	42.60	74.00	31.40
*4 924.00	33.58	Average	V	33.12	-28.98	37.72	54.00	16.28
Above 5 000.00	Not detected	-	-	-	-	-	-	-

The results shown in this test report refer only to the sample(s) tested unless otherwise stated. This test report cannot be reproduced, except in full, without prior written permission of the Company.

SGS Korea Co., Ltd. (Gunpo Laboratory) 4, LS-ro 182beon-gil, Gunpo-si, Gyeonggi-do, Korea, 15807 <http://www.sgsgroup.kr>

OFDM: 802.11n_HT20
 Low Channel (2 412 MHz)

Radiated Emissions			Ant.	Correction Factors		Total	FCC Limit	
Frequency (MHz)	Reading (dB μ V)	Detect Mode	Pol.	AF (dB/m)	CL (dB)	Actual (dB μ V/m)	Limit (dB μ V/m)	Margin (dB)
*2 310.00	20.01	Peak	H	27.77	10.86	58.64	74.00	15.36
*2 310.00	9.98	Average	H	27.77	10.86	48.61	54.00	5.39
*2 385.68	20.63	Peak	H	28.11	9.88	58.62	74.00	15.38
*2 385.68	10.11	Average	H	28.11	9.88	48.10	54.00	5.90
*2 390.00	20.69	Peak	H	28.08	9.86	58.63	74.00	15.37
*2 390.00	10.89	Average	H	28.08	9.86	48.83	54.00	5.17

Radiated Emissions			Ant.	Correction Factors		Total	FCC Limit	
Frequency (MHz)	Reading (dB μ V)	Detect Mode	Pol.	AF (dB/m)	AMP+CL (dB)	Actual (dB μ V/m)	Limit (dB μ V/m)	Margin (dB)
*4 824.04	40.30	Peak	V	32.78	-29.00	44.08	74.00	29.92
*4 824.04	32.78	Average	V	32.78	-29.00	36.56	54.00	17.44
Above 4 900.00	Not detected	-	-	-	-	-	-	-

Middle Channel (2 437 MHz)

Radiated Emissions			Ant.	Correction Factors		Total	FCC Limit	
Frequency (MHz)	Reading (dB μ V)	Detect Mode	Pol.	AF (dB/m)	AMP+CL (dB)	Actual (dB μ V/m)	Limit (dB μ V/m)	Margin (dB)
*4 873.94	39.33	Peak	V	33.01	-28.02	44.32	74.00	29.68
*4 873.94	32.96	Average	V	33.01	-28.02	37.95	54.00	16.05
Above 4 900.00	Not detected	-	-	-	-	-	-	-

The results shown in this test report refer only to the sample(s) tested unless otherwise stated. This test report cannot be reproduced, except in full, without prior written permission of the Company.

High Channel (2 462 MHz)

Radiated Emissions			Ant.	Correction Factors		Total	FCC Limit	
Frequency (MHz)	Reading (dB μ V)	Detect Mode	Pol.	AF (dB/m)	CL (dB)	Actual (dB μ V/m)	Limit (dB μ V/m)	Margin (dB)
*2 483.50	20.13	Peak	H	28.17	9.65	57.95	74.00	16.05
*2 483.50	10.61	Average	H	28.17	9.65	48.43	54.00	5.57
*2 485.86	21.72	Peak	H	28.19	9.68	59.59	74.00	14.41
*2 485.86	11.00	Average	H	28.19	9.68	48.87	54.00	5.13
*2 500.00	20.90	Peak	H	28.31	11.54	60.75	74.00	13.25
*2 500.00	10.44	Average	H	28.31	11.54	50.29	54.00	3.71

Radiated Emissions			Ant.	Correction Factors		Total	FCC Limit	
Frequency (MHz)	Reading (dB μ V)	Detect Mode	Pol.	AF (dB/m)	AMP+CL (dB)	Actual (dB μ V/m)	Limit (dB μ V/m)	Margin (dB)
*4 924.12	39.83	Peak	V	33.12	-28.98	43.97	74.00	30.03
*4 924.12	33.36	Average	V	33.12	-28.98	37.50	54.00	16.50
Above 5 000.00	Not detected	-	-	-	-	-	-	-

The results shown in this test report refer only to the sample(s) tested unless otherwise stated. This test report cannot be reproduced, except in full, without prior written permission of the Company.

SGS Korea Co., Ltd. (Gunpo Laboratory) 4, LS-ro 182beon-gil, Gunpo-si, Gyeonggi-do, Korea, 15807 <http://www.sgsgroup.kr>

OFDM: 802.11n_HT40

Low Channel (2 422 MHz)

Radiated Emissions			Ant.	Correction Factors		Total	FCC Limit	
Frequency (MHz)	Reading (dB μ V)	Detect Mode	Pol.	AF (dB/m)	CL (dB)	Actual (dB μ V/m)	Limit (dB μ V/m)	Margin (dB)
*2 310.00	20.79	Peak	H	27.77	10.86	59.42	74.00	14.58
*2 310.00	10.12	Average	H	27.77	10.86	48.75	54.00	5.25
*2 339.68	19.98	Peak	H	28.05	11.49	59.52	74.00	14.48
*2 339.68	6.63	Average	H	28.05	11.49	46.17	54.00	7.83
*2 390.00	20.24	Peak	H	28.08	9.86	58.18	74.00	15.82
*2 390.00	11.48	Average	H	28.08	9.86	49.42	54.00	4.58

Radiated Emissions			Ant.	Correction Factors		Total	FCC Limit	
Frequency (MHz)	Reading (dB μ V)	Detect Mode	Pol.	AF (dB/m)	AMP+CL (dB)	Actual (dB μ V/m)	Limit (dB μ V/m)	Margin (dB)
*4 844.02	39.17	Peak	V	32.88	-28.68	43.37	74.00	30.63
*4 844.02	32.91	Average	V	32.88	-28.68	37.11	54.00	16.89
Above 4 900.00	Not detected	-	-	-	-	-	-	-

Middle Channel (2 437 MHz)

Radiated Emissions			Ant.	Correction Factors		Total	FCC Limit	
Frequency (MHz)	Reading (dB μ V)	Detect Mode	Pol.	AF (dB/m)	AMP+CL (dB)	Actual (dB μ V/m)	Limit (dB μ V/m)	Margin (dB)
*4 874.10	39.80	Peak	V	33.01	-28.02	44.79	74.00	29.21
*4 874.10	32.61	Average	V	33.01	-28.02	37.60	54.00	16.40
Above 4 900.00	Not detected	-	-	-	-	-	-	-

The results shown in this test report refer only to the sample(s) tested unless otherwise stated. This test report cannot be reproduced, except in full, without prior written permission of the Company.

SGS Korea Co., Ltd. (Gunpo Laboratory) 4, LS-ro 182beon-gil, Gunpo-si, Gyeonggi-do, Korea, 15807 <http://www.sgsgroup.kr>

High Channel (2 452 MHz)

Radiated Emissions			Ant.	Correction Factors		Total	FCC Limit	
Frequency (MHz)	Reading (dB μ V)	Detect Mode	Pol.	AF (dB/m)	CL (dB)	Actual (dB μ V/m)	Limit (dB μ V/m)	Margin (dB)
*2 483.50	21.80	Peak	H	28.17	9.65	59.62	74.00	14.38
*2 483.50	11.04	Average	H	28.17	9.65	48.86	54.00	5.14
*2 486.92	19.95	Peak	H	28.21	9.70	57.86	74.00	16.14
*2 486.92	10.65	Average	H	28.21	9.70	48.56	54.00	5.44
*2 500.00	21.29	Peak	H	28.31	11.54	61.14	74.00	12.86
*2 500.00	10.49	Average	H	28.31	11.54	50.34	54.00	3.66

Radiated Emissions			Ant.	Correction Factors		Total	FCC Limit	
Frequency (MHz)	Reading (dB μ V)	Detect Mode	Pol.	AF (dB/m)	AMP+CL (dB)	Actual (dB μ V/m)	Limit (dB μ V/m)	Margin (dB)
*4 903.94	38.51	Peak	V	33.16	-29.10	42.57	74.00	31.43
*4 903.94	32.04	Average	V	33.16	-29.10	36.10	54.00	17.90
Above 5 000.00	Not detected	-	-	-	-	-	-	-

Remarks :

1. "*" means the restricted band.
2. Measuring frequencies from 1 GHz to the 10th harmonic of highest fundamental frequency.
3. Radiated emissions measured in frequency above 1 000 MHz were made with an instrument using peak/average detector mode.
4. Actual = Reading + AF + AMP + CL or Reading + AF + CL
5. According to § 15.31(o), Emission levels are not reported much lower than the limits by over 20 dB.

The results shown in this test report refer only to the sample(s) tested unless otherwise stated. This test report cannot be reproduced, except in full, without prior written permission of the Company.

SGS Korea Co., Ltd. (Gunpo Laboratory) 4, LS-ro 182beon-gil, Gunpo-si, Gyeonggi-do, Korea, 15807 <http://www.sgsgroup.kr>

3. Transmitter AC Power Line Conducted Emission

3.1. Test Setup

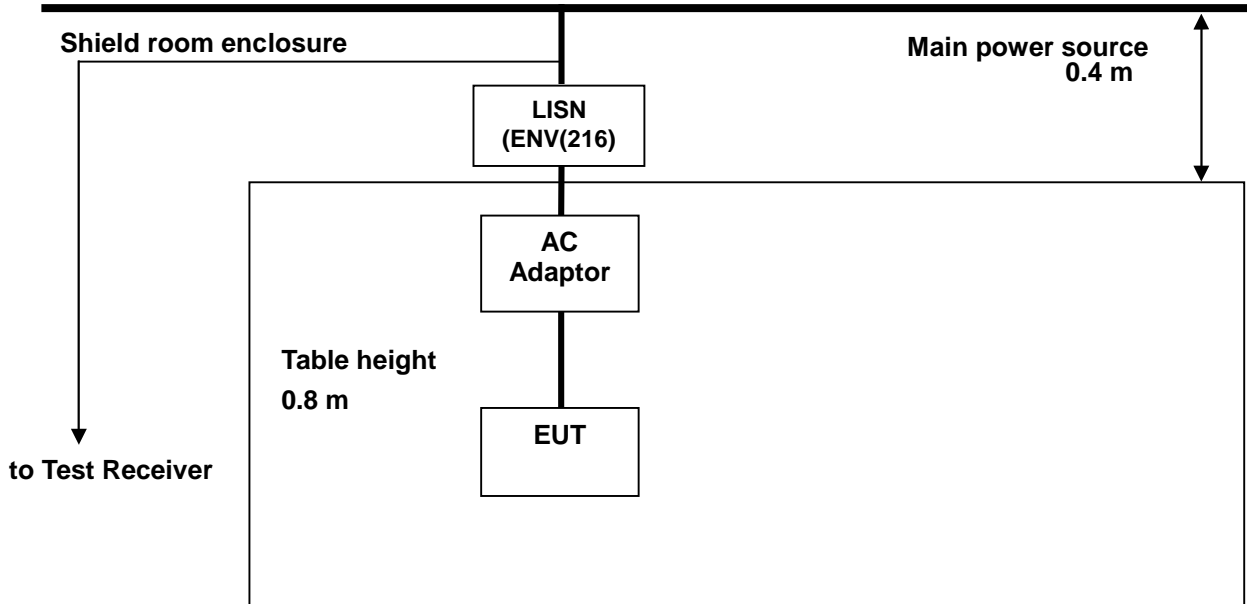

3.2. Limit

According to §15.207(a) for an intentional radiator that is designed to be connected to the public utility (AC) power line, the radio frequency voltage that is conducted back onto the AC power line on any frequency or frequencies, within the band 150 kHz to 30 MHz, shall not exceed the limits in the following table, as measured using a 50 μ H / 50 ohm line impedance stabilization network(LISN).

Compliance with the provision of this paragraph shall on the measurement of the radio frequency voltage between each power line and ground at the power terminal. The lower applies at the boundary between the frequency ranges.

Frequency of Emission (MHz)	Conducted limit (dB μ V)	
	Quasi-peak	Average
0.15 – 0.50	66 - 56*	56 - 46*
0.50 – 5.00	56	46
5.00 – 30.0	60	50

* Decreases with the logarithm of the frequency.

The results shown in this test report refer only to the sample(s) tested unless otherwise stated. This test report cannot be reproduced, except in full, without prior written permission of the Company.

SGS Korea Co., Ltd. (Gunpo Laboratory) 4, LS-ro 182beon-gil, Gunpo-si, Gyeonggi-do, Korea, 15807 <http://www.sgsgroup.kr>

3.3. Test Procedures

All data rates and modes were investigated for this test. The full data for the worst case data rate are reported in this section.

AC line conducted emissions from the EUT were measured according to the dictates of ANSI C63.4-2009

1. The test procedure is performed in a 6.5 m × 3.6 m × 3.6 m (L × W × H) shielded room. The EUT along with its peripherals were placed on a 1.0 m (W) × 1.5 m (L) and 0.8 m in height wooden table and the EUT was adjusted to maintain a 0.4 meter space from a vertical reference plane.
2. The EUT was connected to power mains through a line impedance stabilization network (LISN) which provides 50 ohm coupling impedance for measuring instrument and the chassis ground was bounded to the horizontal ground plane of shielded room.
3. The excess power cable between the EUT and the LISN was bundled. All connecting cables of EUT were moved to find the maximum emission.

The results shown in this test report refer only to the sample(s) tested unless otherwise stated. This test report cannot be reproduced, except in full, without prior written permission of the Company.

SGS Korea Co., Ltd. (Gunpo Laboratory) 4, LS-ro 182beon-gil, Gunpo-si, Gyeonggi-do, Korea, 15807 <http://www.sgsgroup.kr>

3.4. Test Results

The following table shows the highest levels of conducted emissions on both phase of Hot and Neutral line

Ambient temperature : (23 ± 1) °C
 Relative humidity : 47 % R.H.

 Frequency range : 0.15 MHz – 30 MHz
 Measured Bandwidth : 9 kHz

-Normal cover

FREQ. (MHz)	LEVEL(dB μ V)		LINE	LIMIT(dB μ V)		MARGIN(dB)	
	Q-Peak	Average		Q-Peak	Average	Q-Peak	Average
0.17	48.50	36.90	N	64.96	54.96	16.46	18.06
0.43	45.20	37.80	N	57.25	47.25	12.05	9.45
1.33	37.70	30.00	N	56.00	46.00	18.30	16.00
2.80	34.00	26.70	N	56.00	46.00	21.60	19.30
13.74	38.60	30.20	N	60.00	50.00	21.40	19.80
23.14	32.10	21.30	N	60.00	50.00	27.90	28.70
0.17	50.90	38.70	H	64.96	54.96	14.06	16.26
0.30	48.00	38.00	H	60.24	50.24	12.24	12.24
0.47	46.00	38.20	H	56.51	46.51	10.51	8.31
1.76	42.90	34.10	H	56.00	46.00	13.10	11.90
13.27	42.50	33.30	H	60.00	50.00	17.50	16.70
23.86	42.00	25.00	H	60.00	50.00	18.00	25.00

Remark;

1. Line (H): Hot, Line (N): Neutral
2. All modes of operation were investigated and the worst-case emissions were reported using 11b Mode, 1 Mbps, Middle channel.
3. Traces shown in plot mad using a peak detector and average detector
4. The limit for Class B device(s) from 150 kHz to 30 MHz are specified in Section of the Title 47 CFR.
5. Deviations to the Specifications: None.

The results shown in this test report refer only to the sample(s) tested unless otherwise stated. This test report cannot be reproduced, except in full, without prior written permission of the Company.

Plots of Conducted Power line

Test mode: (Neutral)

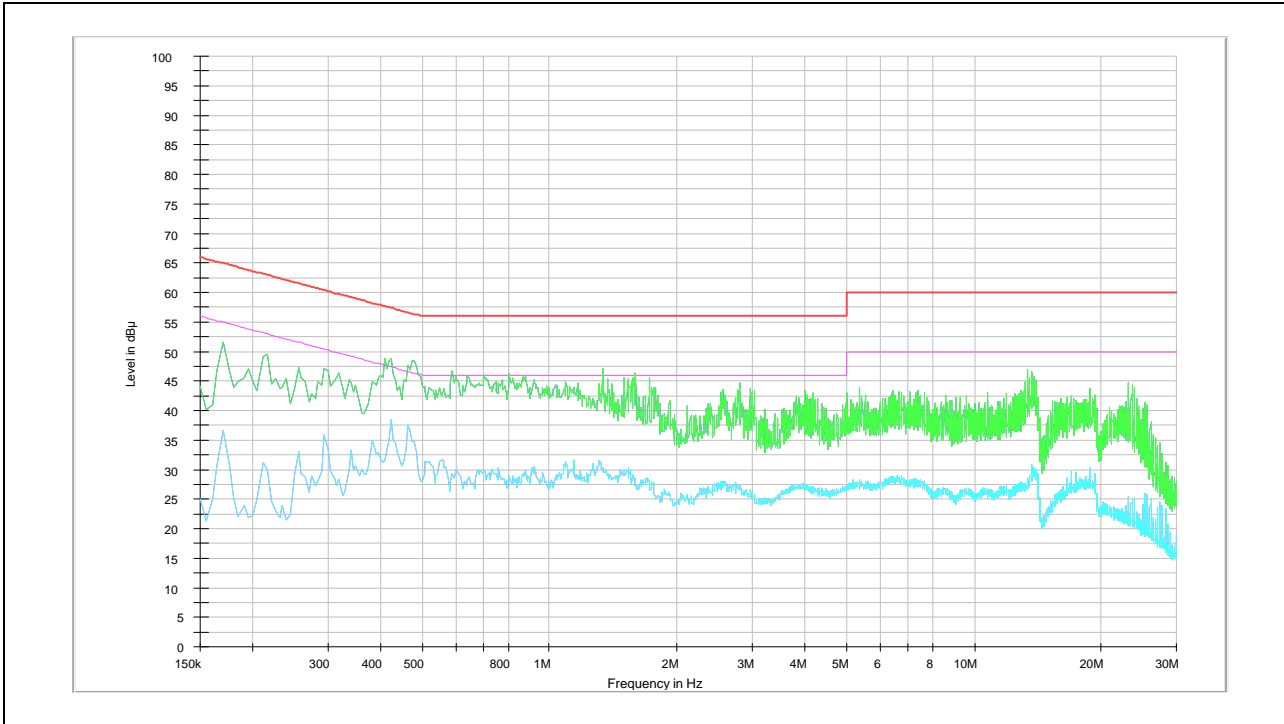

Test mode: (Hot)

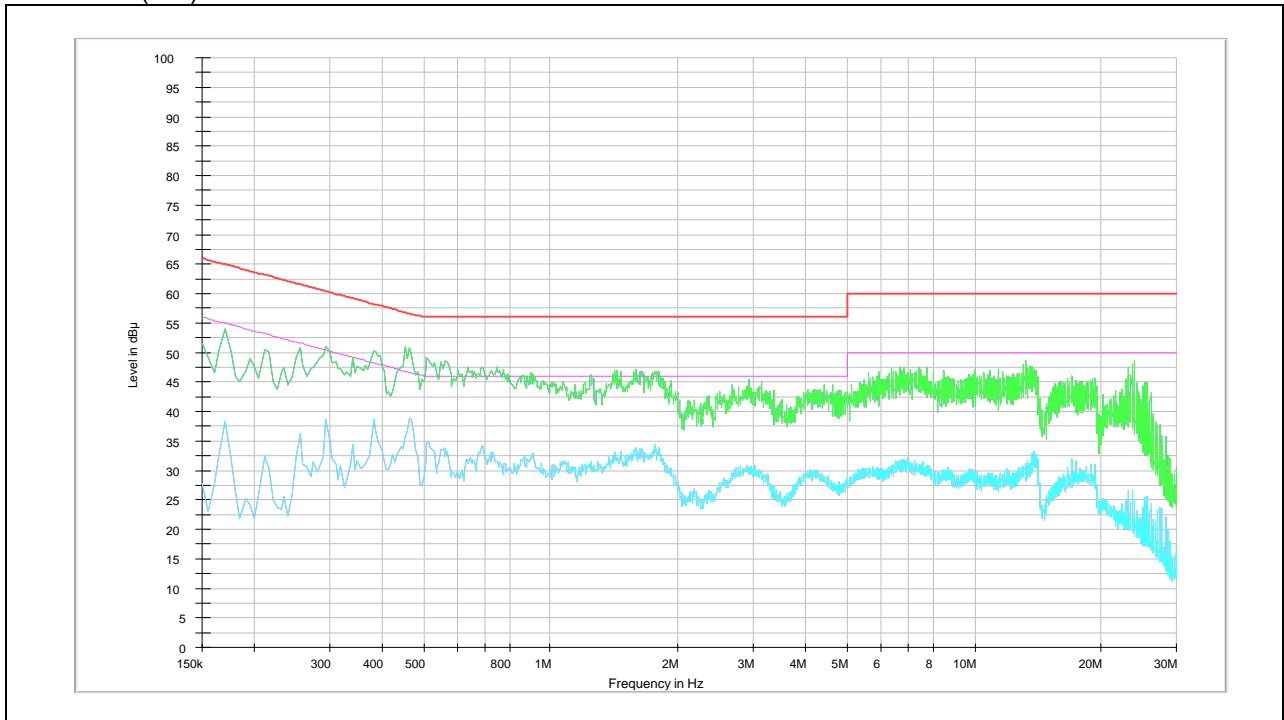

The results shown in this test report refer only to the sample(s) tested unless otherwise stated. This test report cannot be reproduced, except in full, without prior written permission of the Company.

SGS Korea Co., Ltd. (Gunpo Laboratory) 4, LS-ro 182beon-gil, Gunpo-si, Gyeonggi-do, Korea, 15807 <http://www.sgsgroup.kr>