

# Quick-Start Guide



Water Leak Sensor

## Meet your Water Leak Sensor

By placing this wireless ZigBee sensor in areas of your home that are prone to leaking (such as a basement, near a water heater, under an old pipe, or in a bathroom), you can receive an immediate alert on your smartphone at the first sign of excess moisture and prevent a minor headache from causing major damage.

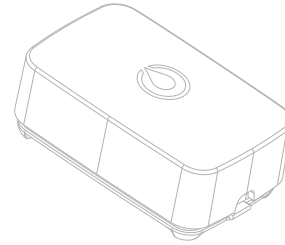

## How to connect a Water Leak Sensor

Select "Connect New Device" in the free SmartThings mobile app and then remove the "Remove to Pair" tab found in the Water Leak Sensor.

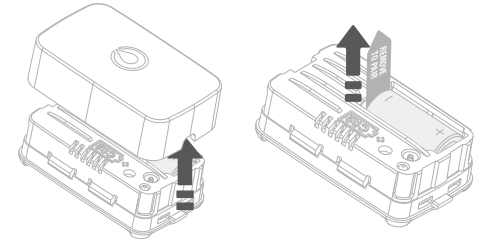

### Installation Tips

The Water Leak Sensor works best if it's within 15 feet (4.5 meters) of the SmartThings Hub when you connect it.

## Water Leak Sensor components

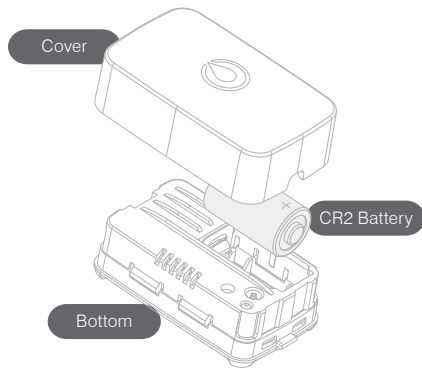

## If your device doesn't connect

If your device doesn't connect after removing the "Remove to Pair" tab, hold the "Connect" button while inserting the battery. Release the button when the LED is lit. The LED will blink blue while attempting to connect. Then select "Connect New Device" in the SmartThings app.

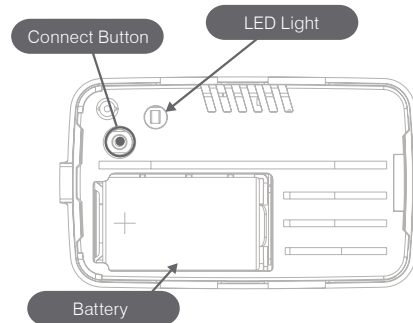

## Placing the Water Leak Sensor

If a pool of water forms, moisture must contact both leads to trigger an alert.



## Placing the Water Leak Sensor

Place the Water Leak Sensor in areas like bathrooms, basements, under clogged drains, under older pipes, or in other areas of your home that are prone to leaking so that you can receive an instant alert.

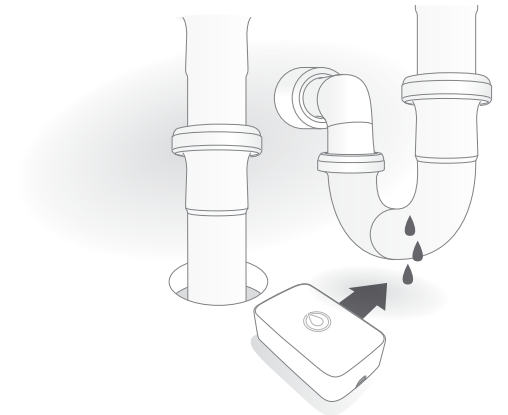

## Replacing the battery

To replace the battery in your Water Leak Sensor, remove device cover to access battery. Remove battery, add a new battery and close the cover back into place.

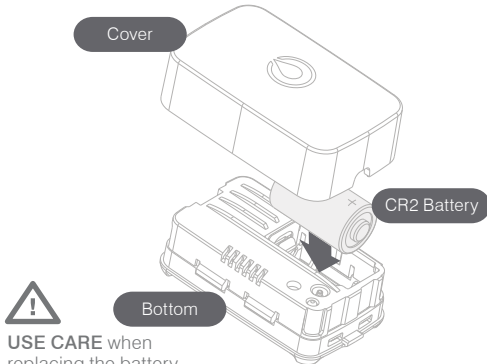

**USE CARE** when replacing the battery to avoid damaging the device.

your personal non-commercial use. You may not use any content or services in a manner that has not been authorised by the content owner or service provider.

Without limiting the foregoing, unless expressly authorised by the applicable content owner or service provider, you may not modify, copy, republish, upload, post, transmit, translate, sell, create derivative works, exploit, or distribute in any manner or medium any content or services displayed through this device.

### Certifications

Hereby, SmartThings Inc. declares that this product is in compliance with the essential requirements and other relevant provisions of Directive 1999/5/EC. The original Declaration of Conformity may be found at [smarthings.com/eu/compliance](http://smarthings.com/eu/compliance).

Certified under FCC Part 15. Certified in Canada by IC to RSS-247.

This Class B digital apparatus complies with Canadian ICES-003

Cet appareil numérique de la classe B est conforme à la norme NMB-003 du Canada.

This device should not be installed or operated within 20cm (8 inches) of persons or other radio emitting devices.

Water Leak Sensor Contains FCC ID : 2AF4S-ST5-WTR-250, IC : 20753-ST5WTR250.

### FCC Statement

Operation of this device is subject to the following two conditions: (1) this device may not cause interference, and (2) this device must accept any interference, including interference that may cause undesired operation of the device.



## Safety Instructions

- Read, keep and follow these instructions
- Heed all warnings
- Do not use this product near water or expose the product to dripping or splashing of any water or liquid
- Clean only with a dry cloth
- Do not install near any heat sources such as radiators, heat registers, stoves or other apparatus (including amplifiers) that produce heat
- Only use attachments and accessories specified by the manufacturer
- Read our Product Usage Guidelines at: <http://SmartThings.com/guidelines>

**CAUTION: RISK OF EXPLOSION IF BATTERY IS REPLACED BY AN INCORRECT TYPE. DISPOSE OF USED BATTERIES ACCORDING TO THE INSTRUCTIONS. VORSICHT. EXPLOSIONSGEFAHR WENN BATTERIEN EINES FALSCHEN TYPUS VERWENDET WERDEN. ENTSORGEN SIE BATTERIEN ENTSPRECHEND DER ANWEISUNGEN. ATTENTION. RISQUE D'EXPLOSION SI LA BATTERIE EST REPLACÉE PAR UN MODÈLE INCORRECT. JETEZ LES BATTERIES USAGÉES SELON LES INSTRUCTIONS S'Y RÉFÉRANT.**

**WARNING: No user-serviceable parts inside. Refer all servicing to qualified service personnel.**

**IMPORTANT CONSUMER INFORMATION: Please read before activating or using the Arrival Sensor.**

**WARNING: This product contains chemicals known to the State of California to cause cancer and reproductive toxicity. For more information, please call 1-800-SAMSUNG (726-7864).**



### Canada Statement

This device complies with Industry Canada license-exempt RSS standard(s). Operation is subject to the following two conditions: (1) this device may not cause interference, and (2) this device must accept any interference, including interference that may cause undesired operation of the device.

Le présent appareil est conforme aux CNR d'Industrie Canada applicables aux appareils radio exempts de licence. L'exploitation est autorisée aux deux conditions suivantes: (1) l'appareil ne doit pas produire de brouillage, et (2) l'utilisateur de l'appareil doit accepter toute brouillage radioélectrique subi, même si le brouillage est susceptible d'en compromettre le fonctionnement.

### Information to the User

Changes or modifications not expressly approved by SmartThings, Inc. could void your authority to operate the equipment.

This equipment has been tested and found to comply with the limits for a Class B digital device, pursuant to Part 15 of the FCC Rules. These limits are designed to provide reasonable protection against harmful interference in a residential installation. This equipment generates and can radiate radio frequency energy and, if not installed and used in accordance with the instructions, may cause harmful interference to radio communications. However, there is no guarantee that interference will not occur in a particular installation. If this equipment does cause harmful interference to radio or television reception, which can be determined by turning the equipment off and on, the user is encouraged to try to correct the interference by one or more of the following measures:

- Reorient or relocate the receiving antenna.
- Increase the separation between equipment and the receiver.
- Connect the equipment to an outlet on a circuit different from that to which the receiver is connected.
- Consult the dealer or an experienced radio/TV technician for help.

## Wichtige Sicherheitshinweise

- Lesen, behalten und folgen Sie diesen Anweisungen
- Beachten Sie alle Warnhinweise
- Verwenden Sie das Produkt nicht in der Nähe von Wasser und vermeiden Sie Tropfen oder Spritzer von Flüssigkeiten jeder Art
- Säubern Sie das Gerät ausschliesslich mit einem trockenen Tuch
- Vermeiden Sie die Installation in der Nähe von Wärmequellen wie Heizungen, Öfen oder anderen Geräten (inkl. Verstärkern), die Hitze produzieren
- Verwenden Sie nur Hersteller zertifiziertes Zubehör

## Règles de sécurité:

- Lire, conserver et suivre ces instructions
- Respecter toutes les consignes de sécurité
- Nettoyer l'appareil uniquement avec un chiffon sec
- Ne pas utiliser à proximité et éviter tout contact avec l'eau ou un quelconque liquide
- Ne pas installer à proximité d'une source de chaleur telle que radiateur, poêle ou autres appareils (incluant les amplificateurs) qui produisent de la chaleur
- Utiliser uniquement des accessoires recommandées par le fabricant



This ZigBee Certified Product works with ZigBee networks supporting the Home Automation Profile.

Global 2.4 GHz wireless use.

ZigBee® Certified is a registered trademark of the ZigBee Alliance.

### One (1) Year Limited Warranty

SmartThings, Inc. warrants this product (the "Product") against defects in materials and/or workmanship under normal use for a period of ONE (1) YEAR from the date of purchase by the original purchaser ("Warranty Period"). If a defect arises and a valid claim is received within the Warranty Period, then as your sole remedy (and SmartThings' sole liability), SmartThings will at its option either 1) repair the defect at no charge, using new or refurbished replacement parts, or 2) replace the Product with a new product that is functionally equivalent to the original, in each case within 30 days following receipt of the returned Product. A replacement product or part, assumes the remaining warranty of the original Product. When a Product or part is exchanged, any replacement item becomes your property and the replaced Product or part becomes SmartThings' property.

Obtaining Service: To obtain warranty service, visit [support.smarthings.com](http://support.smarthings.com) to speak with a service agent or open a service request. Please be prepared to describe the Product that needs service and the nature of the problem. A purchase receipt is required. The Product must be insured, and shipped freight prepaid and securely packaged. You must contact support for a Return Material Authorization Number ("RMA Number") before shipping any Product, and include the RMA Number, a copy of your purchase receipt and a description of the problem you are experiencing with the Product. Any claim under this Limited Warranty must be submitted to SmartThings before the end of the Warranty Period.

Exclusions: This warranty does not apply to: a) damage caused by failure to follow instructions relating to the Product's use or the installation of components; b) damage caused by accident, abuse, misuse, transport, neglect, fire, floods, earthquake or other external causes; c) damage caused by service performed by anyone who is not an authorized representative of SmartThings; d) accessories used in conjunction with a covered Product; e) a Product or part that has been modified to alter functionality or capability; f) items intended to be periodically replaced by the purchaser during the normal life of the Product, including, without limitation, batteries, bulbs or cables; g) a Product that is used commercially or for a commercial purpose, in each case as determined by SmartThings.

### Correct disposal of batteries in this product

(Waste Electrical & Electronic Equipment)

(Applicable in countries with separate collection systems)

This marking on the product, accessories or literature indicates that the product and its electronic accessories (e.g. charger, headset, USB cable) should not be disposed of with other household waste.

To prevent possible harm to the environment or human health from uncontrolled waste disposal, please separate these items from other types of waste and recycle them responsibly to promote the sustainable reuse of material resources.

Household users should contact either the retailer where they purchased this product, or their local government office, for details of where and how they can take these items for environmentally safe recycling.

Business users should contact their supplier and check the terms and conditions of the purchase contract. This product and its electronic accessories should not be mixed with other commercial wastes for disposal.

(Applicable in countries with separate collection systems)

This marking on the battery, manual or packaging indicates that the batteries in this product should not be disposed of with other household waste. Where marked, the chemical symbols Hg, Cd or Pb indicate that the battery contains mercury, cadmium or lead above the reference levels in EC Directive 2006/66. If batteries are not properly disposed of, these substances can cause harm to human health or the environment.

To protect natural resources and to promote material reuse, please separate batteries from other types of waste and recycle them through your local, free battery return system.

### Disclaimer

Some content and services accessible through this device belong to third parties and are protected by copyright, patent, trademark and/or other intellectual property laws. Such content and services are provided solely for



EXCEPT FOR BODILY INJURY, SMARTTHINGS SHALL NOT BE LIABLE FOR (I) ANY LOST PROFITS, COST OF PROCUREMENT OF SUBSTITUTE PRODUCTS, OR ANY INCIDENTAL OR CONSEQUENTIAL DAMAGES, OR (II) ANY AMOUNTS IN EXCESS OF THE PURCHASE PRICE FOR THE PRODUCT, IN EACH CASE WHETHER RESULTING FROM THE USE OF OR INABILITY TO USE THIS PRODUCT, OR ARISING OUT OF ANY BREACH OF THIS WARRANTY, EVEN IF COMPANY HAS BEEN ADVISED OF THE POSSIBILITY OF SUCH DAMAGES. SOME STATES DO NOT ALLOW THE EXCLUSION OR LIMITATION OF INCIDENTAL OR CONSEQUENTIAL DAMAGES, SO THE ABOVE LIMITATION AND EXCLUSIONS MAY NOT APPLY TO YOU.

TO THE EXTENT PERMITTED BY APPLICABLE LAW, SMARTTHINGS DISCLAIMS ANY AND ALL STATUTORY OR IMPLIED WARRANTIES, INCLUDING WITHOUT LIMITATION, WARRANTIES OF MERCHANTABILITY, FITNESS FOR A PARTICULAR PURPOSE AND WARRANTIES AGAINST HIDDEN OR LATENT DEFECTS. IF SMARTTHINGS CANNOT LAWFULLY DISCLAIM STATUTORY OR IMPLIED WARRANTIES, THEN TO THE EXTENT PERMITTED BY LAW, ALL SUCH WARRANTIES SHALL BE LIMITED IN DURATION TO THE WARRANTY PERIOD. SOME STATES DO NOT ALLOW LIMITATIONS ON HOW LONG AN IMPLIED WARRANTY LASTS, SO THE ABOVE LIMITATIONS MAY NOT APPLY TO YOU.

This warranty gives you specific legal rights and you may also have other rights, which vary from state to state. To exercise your rights under this warranty, please follow the instructions above under the heading "Obtaining Service", or contact SmartThings at SmartThings, Inc., 456 University Ave. Suite 200, Palo Alto, CA 94301, USA.

Samsung is a registered trademark of Samsung Electronics Co., Ltd.