

UHF RFID reader  
CSH-20013  
User's manual and  
Specifications

# Table of contents

1. First of all.....	3
1.1. Scope of application.....	3
1.2. Definition of terms .....	3
1.3. Notes on RFID devices .....	4
1.4. Wireless certification .....	4
1.5. Safety precautions .....	6
1.6. About product warranty .....	7
2. Overview .....	8
2.1. Equipment Overview .....	8
2.2. Basic functions .....	8
2.3. Part names and functions .....	10
2.4. Internal Configuration.....	103
2.5. Tag reading method .....	13
3. Specifications .....	14
3.1. General specification.....	145
3.2. RFID part specification.....	156
3.3. Antenna specifications .....	167
3.4. LED indicator specifications .....	178
3.5. Dip switch specifications .....	189
3.6. External output terminal specification .....	20
3.7. LAN Specifications .....	212
4. Reliability .....	212
4.1. Reliability test .....	212
5. Green procurement .....	212
6. External dimensions .....	223
7. Packing specification .....	234
7.1. Parts list .....	234
7.2. Packing procedure .....	234
7.3. Packing box (grouping box) .....	234
8. Maintenance.....	234
9. Other notes.....	234

# 1. First of all

## 1.1. Scope of application

This document defines product specifications for Teraoka Seiko Co., Ltd. UHF band RFID fixed reader.

Product name: UHF RFID reader

Product type: CSH-20013 (Linea polarized antenna model)

Hereafter, this device is called "UHF reader".

## 1.2. Definition of terms

Table 1-2 shows the terms and abbreviations used in this document.

**Table 1-2 Definitions of terms and abbreviations**

Term	Description
UHF reader	UHF band RFID reader for Teraoka Seiko Co., Ltd.
EPCglobal	Non-profit corporation promoting international standardization of RFID.
Class 1 Generation 2	920 MHz band RFID standard established by EPCglobal. Also called C1G2 or Gen2 for short
ISO / IEC 18000-63	Standard number assigned EPCglobal Class 1 Generation 2 as international standard. It has been renamed from former ISO / IEC 18000-6 Type C. Synonymous with Class 1 Generation 2.
RF tag (tag)	RFID tag. In this document, refers to the tag corresponding to Class 1 Generation 2
UID	Stands for Unique Item identification. It is used to assign unique ID different for each tag and to perform individual management.
EPC	Electronic Product Code Generic term for identification code to write to RF tag.
LED	Light Emitting Diode
TBD	"To Be Determined". Currently undecided, but means to decide later.
Gain (antenna gain)	A number that indicates the performance of the antenna. The larger the value, the stronger the transmission and reception radio waves. That is, even at the same power, the reading distance of the tag changes due to the difference in antenna gain.

### 1.3. Notes on RFID device

This device is a reader / writer for RFID using radio waves. Therefore, depending on the intended use and location, it may affect the medical equipment. In order to reduce this impact, please observe the following in operation.

Countermeasures for implantable medical device wearers of stationary type and module type (including printer type) RFID devices are as follows.

Do not bring it closer than 22cm from the antenna part of the RFID device.

### 1.4. Wireless certification

This product is wirelessly certified or registered according to the laws of the country of use.

#### **for SINGAPORE**

Short Range Devices

Radio Frequency Identification (RFID) Equipment

Operating in the 920 – 925 MHz Bands

Complies with  
IMDA Standards  
DA104304

\*\*\*Registration number is determined after registration

#### **for USA**

Model:CSH-20013

FCC ID: 2AF4P- CSH17136

Operating in the 915.125 – 927.375MHz

This device complies with part 15 of the FCC Rules. Operation is subject to the following two conditions: (1) This device may not cause harmful interference, and (2) this device must accept any interference received, including interference that may cause undesired operation.

#### Contact Details

DIGI America Inc.

76 Veronica Avenue, Somerset, NJ 08873, U.S.A. +1-732-828-3633

<https://www.digisystem.com/us/company/access-map/>

## FCC CAUTION

Changes or modifications not expressly approved by the party responsible for compliance could void the user's authority to operate the equipment.

### Note:

This equipment has been tested and found to comply with the limits for a Class A digital device, pursuant to part 15 of the FCC Rules. These limits are designed to provide reasonable protection against harmful interference when the equipment is operated in a commercial environment. This equipment generates, uses and can radiate radio frequency energy and, if not installed and used in accordance with the instructions manual, may cause harmful interference to radio communications. Operation of this equipment in a residential area is likely to cause harmful interference to radio communications. Operation of this equipment in a residential area is likely to cause harmful interference in which case the user will be required to correct the interference at his own expense.

### Note:

This transmitter must not be co-located or operated in conjunction with any other antenna or transmitter.

## RF Exposure Compliance

This equipment complies with FCC radiation exposure limits set forth for an uncontrolled environment and meets the FCC radio frequency (RF) Exposure Guidelines. This equipment should be installed and operated keeping the radiator at least 20cm or more away from person's body.

## 1.5. Safety precautions

Please read the "Safety Precautions" carefully before use and use it properly.



- Do not disassemble or modify the equipment. It may cause an accident such as injury, electric shock or fire.
- Do not use near electronic devices that handle high precision control or weak signals. Electronic devices (medical electronic devices, fire alarms, automatic doors, other automatic control devices, etc.) may be affected by malfunctions.
- Keep away from chemicals. Do not use or store near or in contact with chemicals. It may cause an electric shock, fire or other accident or failure.
- Do not use in a place where there is a risk of ignition or explosion. Using in a place where flammable gas or dust is generated may cause an explosion or fire.
- Do not let foreign objects enter the crisis. If foreign matter or liquid gets inside the device, disconnect the connection cable to discontinue use, and contact your dealer. Continuing to use the product may result in an electric shock, fire, or other accident or failure.
- This equipment has been developed, intended and licensed for use in equipment whose failure directly threatens human life or which affects the human body (nuclear control, aerospace, transportation equipment, combustion equipment, various safety equipment, etc.) It is not.
- Do not use or store in a hot place, humid or dusty place. Do not use or store in places exposed to direct sunlight or high temperatures. It may cause an accident such as a fire, or deformation or failure of the case.
- Please do not get wet. Do not use in places where it may be exposed to rain, showers, etc. Moisture may get inside and cause an electric shock, fire or other accident or failure.
- Do not give a strong impact. Do not drop, throw, or hit equipment. It will be the cause of the failure.
- Use specified equipment and parts. Be sure to use the supplied or specified parts for parts such as connection cables. It may cause a malfunction or malfunction.
- Do not short the power supply. Do not short (contact) the electrodes of the AC adapter with metal such as safety pins or clips, or touch them with your hands or fingers. There is a risk of fire, electric shock, injury or other accidents.
- Do not damage or process the power cord. If you put a heavy object on it, pull it, or bend it forcibly, it may damage the power cord and cause an accident such as a fire or an electric shock.
- Use only the supplied AC adapter. Using any other AC adapter may cause an electric shock,

fire or other accident or failure.

- Do not touch the power plug with wet hands. There is a risk of electric shock.
- When abnormality such as fever, smoke, abnormal odor occurs, unplug the AC adapter from the outlet immediately. Continued use may cause fire, electric shock or injury.

### **Caution**

- Do not place in an unstable place. The equipment may fall or fall, resulting in injury or equipment failure.
- Keep out of reach of children. It may cause injury.
- Be sure to unplug the AC adapter from the outlet when installing, removing, or cleaning this device. There is a risk of electric shock.
- When not using for a long time, be sure to unplug the AC adapter from the outlet. It may cause fire, electric shock or malfunction.
- About maintenance  
If it gets dirty, wipe it with a soft, dry cloth.  
If the stains are severe, immerse the cloth in a mild detergent diluted with water, squeeze well, wipe off, and finish with a dry cloth.

## 1.6. About product warranty

The free warranty period for this product is one year after delivery inspection. Even within the warranty period, you may be charged for the following cases. There is no warranty attached to this product.

- Manufacturing is not numbered, and can not be confirmed (because it is impossible to control the shipping date).
- Failure due to the usage method described in the manual etc. and the handling contrary to the precautions.
- Failure due to intention or serious negligence.
- Failure due to use environment deviating from specified conditions.
- Failure due to unauthorized modification or connection or installation of other devices.
- Failure due to natural disasters such as disasters, earthquakes and floods.
- Failure due to customer-created software and systems.
- Failure due to consumption that can not be avoided in use Equipment replacement (Consumables replacement).

The contents of this product are subject to change without notice due to improvements and version upgrades. Please note that we are not responsible for any loss resulting from the operation of this product.

## 2. Overview

### 2.1. Equipment Overview

This UHF reader is a device installed in a conveyor in a rotating sushi store and reading a UHF RF tag attached to a sushi plate flowing at the top. By reading the sushi plate constantly using RFID, it is possible to manage freshness and manage the sales situation of each sushi item in real time.

The normal operation of the UHF reader is controlled by a command from the host to raise the EPC of the sushi plate that rolls on the conveyor to the reading host. There is no data transmission when there is no sushi plate, but a response is periodically returned in the sense of KEEP ALIVE. As another function, after the sushi plate passes through the dishwasher, it has an output terminal for reading the tag and sorting the plate, and using the classification signal output from the external terminal, the sorter attached to the dishwasher can separate the dishes.

This UHF reader is a specified low power radio station under the Radio Law. Since the wireless certification has been obtained, there is no need to register or license a wireless station to use it, and it can be used immediately after purchase.

### 2.2. Basic functions

The UHF reader has the following basic functions:

#### 1. UHF band RF tag reading

It has a function to read an RF tag in accordance with ISO / IEC 18000-63 (EPCglobal Class 1 Generation 2) by a command from the host. The area of the tag to be accessed is the EPC area.

If there is no tag or reading of the tag fails for any reason, the data is not sent and it proceeds to the next reading operation.

If there is no continuous tag reading, a response will be returned within 2 seconds in the sense of KEEP ALIVE.

#### 2. LED indicator

The operating state of the UHF reader can be inferred from the LED indicator and the lighting state.

There are three types of LED indicators: "POWER LED", which indicates that the power is on, "Communication(通信) LED", which indicates the reading status of the UHF reader, and "RESERVE LED," which is reserved and can be lit as a software in the future. Each LED can change lighting specification by software change.



3. Firmware update function

Firmware update is performed by connecting a dedicated debugger to the connector inside the case.

When updating the firmware, basically we will send back in our company.

4. Shipping inspection function

There are no special functions for shipping inspection of products, and inspections are performed using ordinary commands.

5. Sushi tray sorting external output terminal

Reads data from sushi plate tag and outputs 4-bit TTL level.

### 2.3. Part names and functions

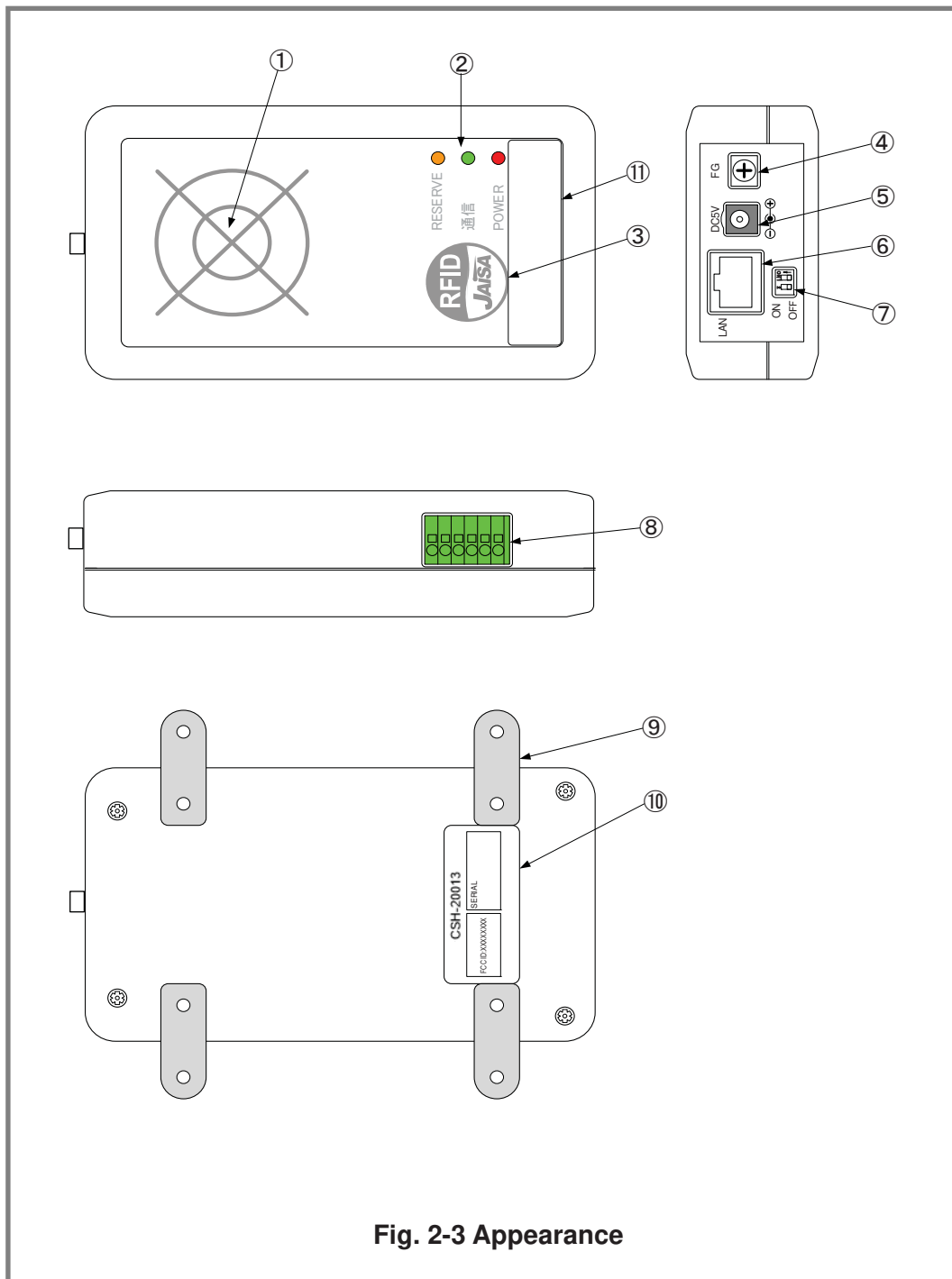

Fig. 2-3 Appearance

**Table 2-3 Names of Parts**

No.	Name	Descriptions
①	Antenna mark	Display of antenna center
②	LED indicator	Red: POWER.....Lit when power is ON Green: 通信.....Flashing when communicating Orange: RESERVE....TBD
③	RFID sticker mark	RFID sticker display (Japanese RFID guidelines)
④	FG terminal	FG connection terminal
⑤	DC5V input jack	AC adapter connector
⑥	LAN connector	LAN (RJ45) connection connector
⑦	Operation mode setting SW	TBD
⑧	External output terminal	External output terminal for tag discrimination
⑨	Mounting feet	Case mounting feet (accessory)
⑩	Product label	Product name, serial number, wireless certification number etc. displayed
⑪	FCC label (USA Only)	Statement required by FCC

## 2.4. Internal configuration

The main parts that make up this product are shown below.

**Table 2-4 Board Configuration**

Item	Descriptions
LAN board	A board equipped with an Xport that converts LAN-UART. Other microcomputers, power supply circuits, LEDs, and external output terminal blocks are mounted.
UHF module	A board with an RF tag read / write function.
Antenna	Antenna to access the RF tag.
AC adapter	AC adapter that supplies DC power to the main unit. There is no power switch on the main unit, so plugging the AC adapter into the main unit turns on the power.

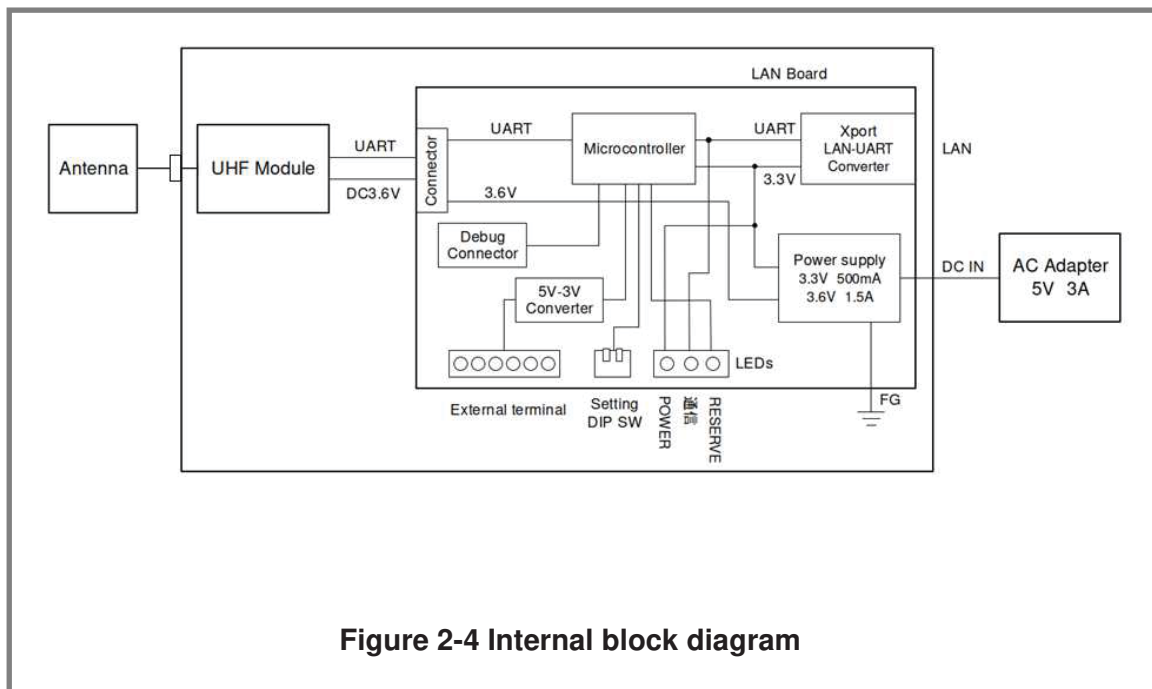

**Figure 2-4 Internal block diagram**

## 2.5. Tag reading method

When reading and writing tags, hold the tag over the reader as shown below.

The reader antenna is linearly polarized, so the tag direction is read according to the polarization direction. Please note that the reading distance will be drastically reduced when the IC tag is cross polarized or perpendicular to the antenna surface (the direction shown in the figure below).

See Fig. 3-3 for the polarization image.

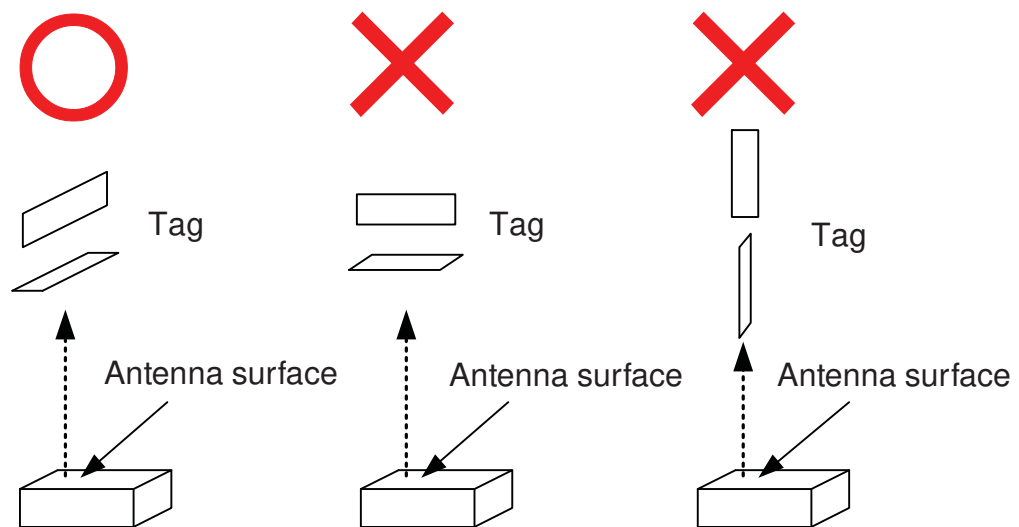

Reading distance varies depending on the surrounding environment and Tag specifications. If the Tag cannot be read even under the above conditions, the location may be a null point. If the distance from the IC tag is around several centimeters, reading may improve.

## 3. Specifications

### 3.1. General specification

Table 3-1 shows the general specifications.

**Table 3-1 General Specifications.**

Item	Descriptions	
Microcontroller	16bit CPU Memory FROM: 256 Kbytes SRAM: 24 Kbytes	
RFID	As shown in the RFID Unit specifications in Section 3.2	
Antenna	As shown in the antenna specifications in Section 3.3	
Display LED	POWER	Red: Lights up when the internal power supply 3.3V is turned on. (Always on during operation)
	通信	Green: Lights in conjunction with data transmission from the UHF module. (If the tag is read, it lights up intermittently)
	RESERVE	Orange: Reserved (for future extensions)
External terminal	DC IN	AC adapter input connector included
	LAN	Connect to LAN (RJ45 connector)
	DIP SW	Operating mode setting dip switch
	FG	Connect to frame ground
	External output terminal	Sushi plate identification output terminal (TTL level)
External dimensions	Body: 76mm (W) x 35mm (H) x 135mm (D) Not including protrusions	
Weight	Body: 235 g (not including fixed feet)	
Environment	Operating temperature	0 to 40 °C
	Operating humidity	20 to 80% (without condensation)
	Storage temperature	-5 to 45 °C
	Storage humidity	10 to 90% (without condensation)
	Waterproof structure	Incompatible

### 3.2. RFID part specification

Table 3-2 shows the specifications of the RFID unit.

**Table 3-2 RFID Unit Specifications**

Item	Descriptions	
Communication standard	ISO/IEC 18000-63 (EPC global Class1 Generation2)	
Transmission output	Maximum output	250mW (Average power) Tolerance:+ 20%, -50%
	Variable range	0 to 24 dBm 25 steps (1 dB step)
Operating frequency	915.125 to 927.375MHz    250kHz step 50ch	
Modulation method	Reader → tag	PRASK, 40 kbps
	Tag → Reader	Mirror subcarrier, link frequency 160 kbps / M4
Frequency tolerance	±5ppm	
Reading distance * 1	Follow our company's XIT-261-G	
Correspondence RF tag	ISO / IEC 18000-63 Compliant tag (Sushi plate sticky tag)	
Multiple simultaneous reading function	With anti-collision function	
Channel used	1ch to 50ch	

\* 1 Reading distance varies according to antenna specifications, tag specifications and operating environment.

### 3.3. Antenna specifications

Table 3-3 shows the specifications of the antenna.

**Table 3-3 Antenna specifications**

Item	Contents
Ceramic Patch antenna	Patch size :100mm x 24mm x 3 or 7mm
Center frequency	920MHz $\pm$ 2MHz
VSWR	1.4 or less
Gain (max)	1 dBi or less
Impedance	50 $\Omega$
Polarization	Linear polarization
Directionality * 2	Upward direction of antenna element (see the figure below)

\* 2 Antenna directivity is shown in Figure 3-3.

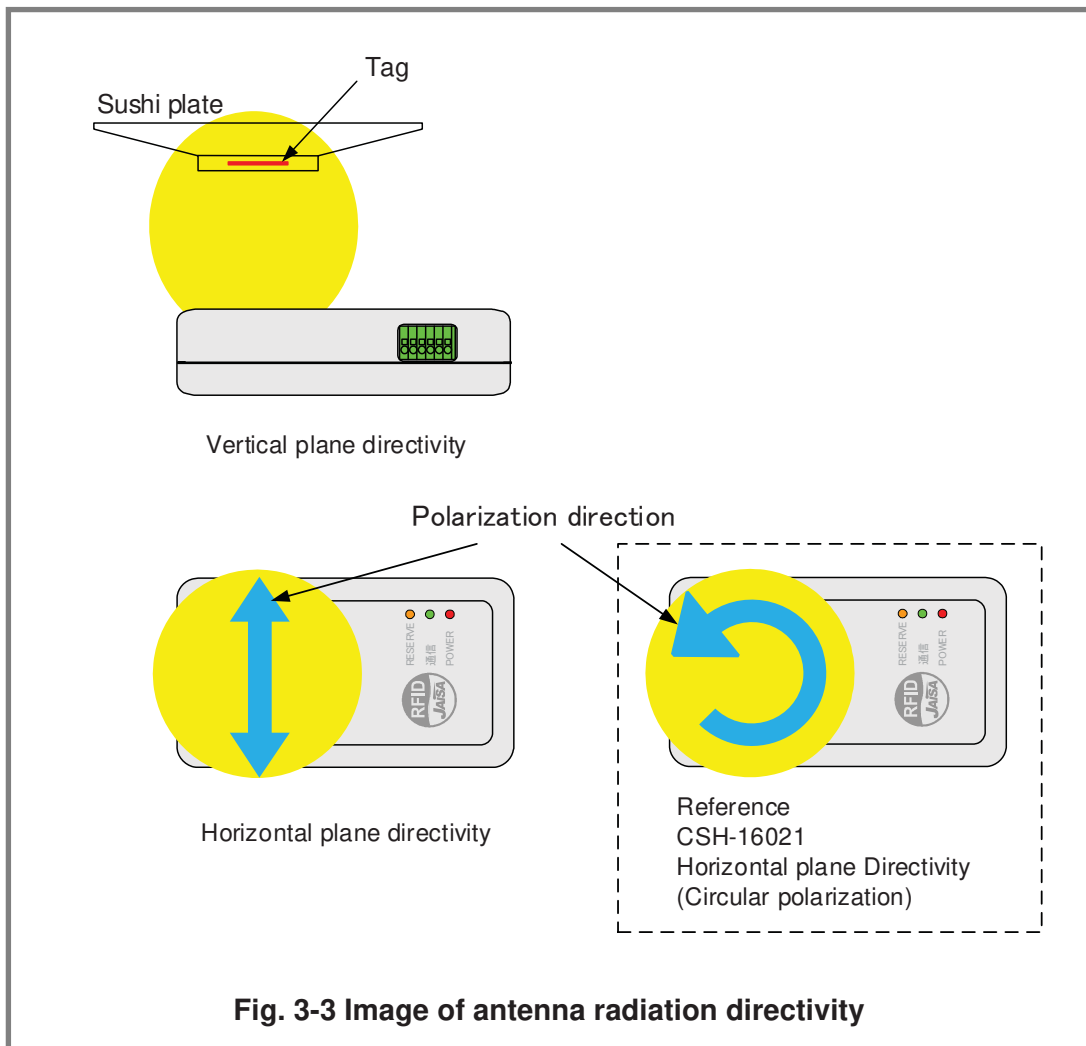



### 3.4. LED indicator specifications

The LED indicator specifications are as follows. The lighting color of the LED is indicated by the background color of the cell (one of green, orange and red).

**Table 3-4 LED Indicator Specifications**

No	Status	POWER (LED2)	通信 (LED2)	RESERVE (LED3)	Operating condition
1	Power on	Lights up			AC adapter is connected. It turned on.
2	Power off	Off			There is no power. AC adapter is not connected.
3	When reading tags		Blink		Flashing fast. Reading RF tag and transmitting data.
4	There is no tag		Off (Temporarily lit)		Not read the RF tag. It has not received a command from the host. Send KEEP ALIVE data within 2 seconds. (Temporarily lit)
5	Power on			Lights off	LED not used.



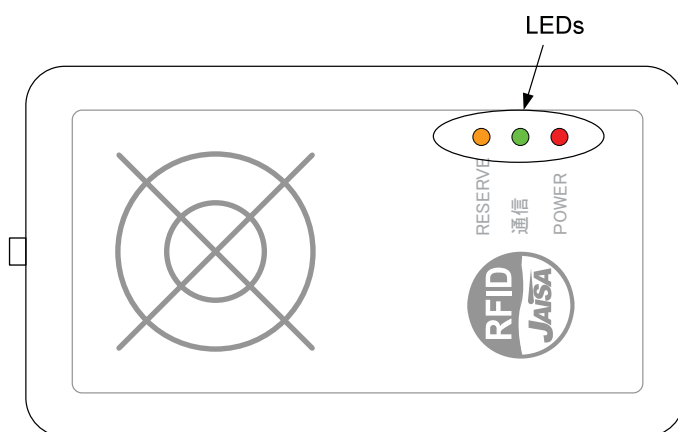





Each LED lights up temporarily at startup.



### 3.5. Dip switch specifications

The relationship between the dip switch status and the operation mode is as follows.

**Table 3-5 Operation mode specifications**

DIP SW status	Operating mode
ON  OFF 	Normal mode. The set value is not stored.
ON  OFF 	Setting value storage mode. Although the operation is the same as in the normal mode, the contents of the parameter setting command are stored in the non-volatile memory as setting values.
ON  OFF 	Automatic InventoryRing mode. Automatically issue the InventoryRing command after power on. The stored setting values are not used.
ON  OFF 	Automatic InventoryRing mode. Automatically issue the InventoryRing command after power on. The contents of the stored setting value are reflected on the UHF module to operate.

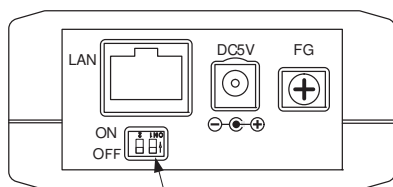

DIP SW

### 3.6. External output terminal specification

The external output terminal is a terminal for outputting a signal for reading and sorting the tag of the plate after washing the sushi plate with the dishwasher.

**Table 3-5 External output terminal specifications**

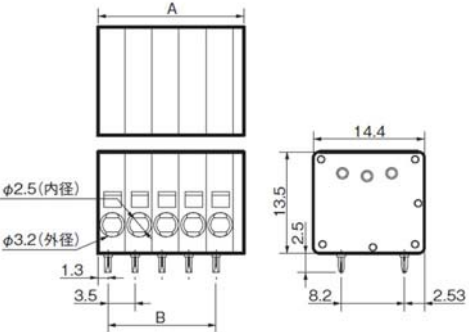
Item	Descriptions	
Connector	Manufacturer: Omron Product number: Model XW4C-06D1-H1 Number of poles: 6P   	
Terminal pitch	3.5mm	
Wire stripping length	10mm±1mm	
Applicable wire	Single line	0.2mm <sup>2</sup> - 1.5mm <sup>2</sup>
	Stranded wire	0.2mm <sup>2</sup> - 1.5mm <sup>2</sup>
	AWG	24-26
Bar terminal	There is a sleeve	0.25mm <sup>2</sup> - 0.75mm <sup>2</sup>
	No sleeve	0.25mm <sup>2</sup> - 1.5mm <sup>2</sup>

**Table 3-6 Output signal specifications**

Terminal No.	Signal name	Function
1	D4	16 kinds of identification are performed by 4 bits of D1 to D4. (MSB)
2	D3	
3	D2	
4	D1	
5	OE	Synchronization signal output. Inverts the level when the read data changes.
6	GND	GND

\*3 Be careful with the arrangement of D1 to D4.

Terminal number

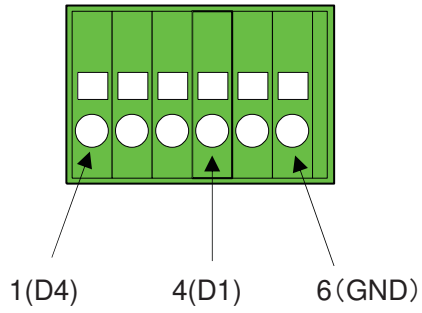

Terminal 1 to 5

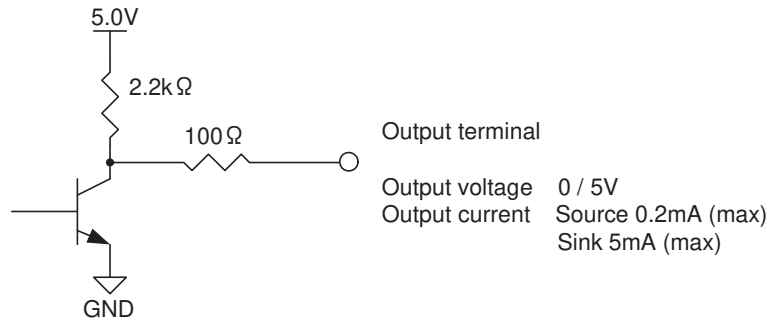

Terminal 6



**Figure 3-4 External output terminal Internal circuit**

### 3.7. LAN Specifications

The IP initial setting of LAN is DHCP. To change the setting, prepare a separate document.

**Table 3-7 LAN Specifications**

Item	Function
Support protocol	TCP / IP
Communication compatible	Ethernet: Version 2.0 / IEEE 802.3
Ethernet interface	RJ45 (10BASE-T, 100BASE-TX)
LED	10Base-T & 100Base-TX, Link & activity indicator-Full / half duplex. (Not compatible with 10Bass-T Full Duplex fixed)

## 4. Reliability

### 4.1. Reliability test

Test results are shown in the attached "Test result table".

## 5. Green procurement

All components adopted in this product conform to the "IAS Green Procurement Guidelines 4th Edition".

(It becomes correspondence from mass product.)

## 6. External dimensions

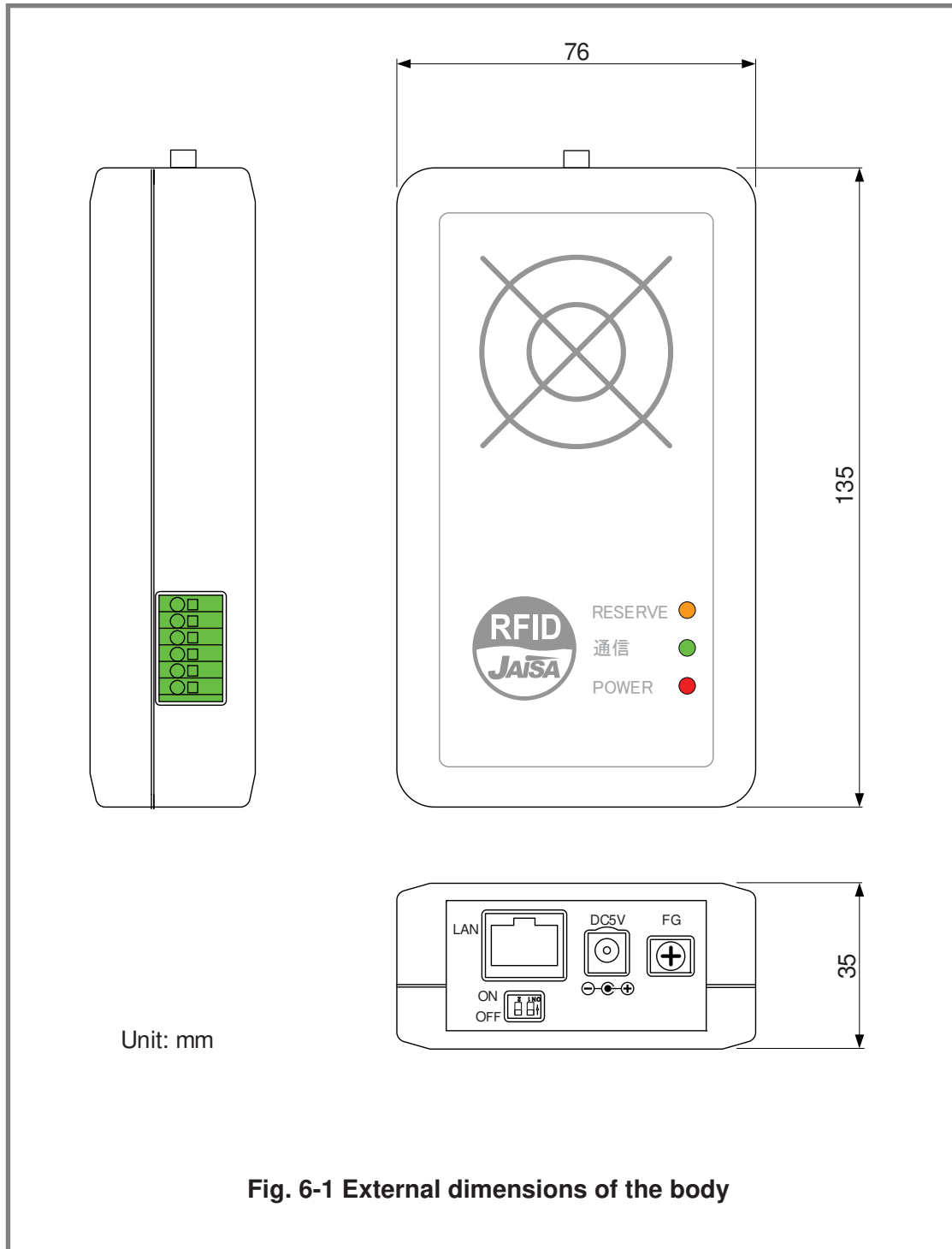

## 7. Packing specification

### 7.1. Parts list

**Table 7-1 Package parts list**

No	Name (provisional)	type of packing
1	UHF RFID reader	Undecided
2	AC adapter (including AC cord)	
3	Accessories (fixed feet)	

### 7.2. Packing procedure

To be determined.

### 7.3. Packing box (grouping box)

As this product is a prototype, the packaging box has not been determined. We decide after consultation with Teraoka Seiko Co., Ltd. at the time of mass production shift.

## 8. Maintenance

Maintenance and repair methods will be discussed separately.

## 9. Other notes

- The reading of the RF tag to be used should be thoroughly tested, and the placement of the RF tag and the UHF reader should be placed at a sufficient reading distance. UHF readers are affected by the surrounding environment. Be especially careful with metals.
- This product does not have a waterproof structure, so be careful when installing it in a place where it will be exposed to water droplets.
- Bundle the cables of the AC adapter cord and the external output terminal so that they do not hang around the antenna. It may affect the reading of RF tags.
- About maintenance  
If it gets dirty, wipe it with a soft, dry cloth. If the stain is severe, immerse the cloth in a mild detergent diluted with water, squeeze it well, wipe it off, and finish with a dry cloth.
- About lighting of use environment  
Some fluorescent light fixtures generate noise and affect the reader's reading. Hf-type fluorescent lamps are driven at high frequency by an inverter, and it has been confirmed

that the reading distance decreases when used near. Please be careful when installing the leader.

---

UHF RFID reader  
CSH-20013  
User's manual and Specifications

---