



Part 15C

TEST REPORT

Product Name	CDMA alarm device w/GPS receiver
Model Name	DS600
FCC ID	2AF36-DS600
Client	Mobilelock LLC
Manufacturer	Asiatelco Technologies Co
Date of issue	March 10, 2016

TA Technology (Shanghai) Co., Ltd.

TA Technology (Shanghai) Co., Ltd.
Test Report

GENERAL SUMMARY

Reference Standard(s)	<p>FCC CFR47 Part 15C (2014) Radio Frequency Devices</p> <p>15.205 Restricted bands of operation;</p> <p>15.207 Conducted limits;</p> <p>15.209 Radiated emission limits; general requirements;</p> <p>15.247 Operation within the bands 902-928 MHz,2400-2483.5 MHz, and 5725-5850MHz.</p> <p>ANSI C63.10 Methods of Measurement of Radio-Noise Emission from Low-Voltage Electrical and Electronic Equipment in the Range of 9 KHz to 40GHz. (2013)</p> <p>KDB 558074 D01 DTS Meas Guidance v03r03 Guidance for Performing Compliance Measurements on Digital Transmission Systems (DTS) Operating Under §15.247</p>
Conclusion	<p>This portable wireless equipment has been measured in all cases requested by the relevant standards. Test results in Chapter 2 of this test report are below limits specified in the relevant standards.</p> <p>General Judgment: Pass</p>
Comment	<p>The test result only responds to the measured sample.</p>

Approved by *Kai Xu*
Kai Xu
Director

Revised by *Lingling Kang*
Lingling Kang
RF Manager

Performed by *Changxu Wan*
Changxu Wan
RF Engineer

TABLE OF CONTENT

1. General Information	4
1.1. Notes of the test report	4
1.2. Testing laboratory	5
1.3. Applicant Information	5
1.4. Manufacturer Information	5
1.5. Information of EUT	6
1.6. Test Date	6
2. Test Information	7
2.1. Test Mode	7
2.2. Summary of test results	8
2.3. Peak Power Output –Conducted	9
2.4. 6dB Occupied Bandwidth	12
2.5. Band Edge Compliance	15
2.6. Power Spectral Density	17
2.7. Spurious Radiated Emissions in the Restricted Band	20
2.8. Spurious RF Conducted Emissions	24
2.9. Radiates Emission	28
2.10. Conducted Emission	43
3. Main Test Instruments	51
ANNEX A: EUT Appearance and Test Setup	52
A.1 EUT Appearance	52
A.2 Test Setup	53

TA Technology (Shanghai) Co., Ltd.

Test Report

Report No.: RXA1507-0128RF03R3

Page 4 of 54

1. General Information

1.1. Notes of the test report

TA Technology (Shanghai) Co., Ltd. has obtained the accreditation of China National Accreditation Service for Conformity Assessment (CNAS), and accreditation number: L2264.

TA Technology (Shanghai) Co., Ltd. has been listed on the US Federal Communications Commission list of test facilities recognized to perform electromagnetic emissions measurements. The site recognition number is 428261.

TA Technology (Shanghai) Co., Ltd. has been listed by industry Canada to perform electromagnetic emission measurement. The site recognition number is 8510A.

TA Technology (Shanghai) Co., Ltd. guarantees the reliability of the data presented in this test report, which is the results of measurements and tests performed for the items under test on the date and under the conditions stated in this test report and is based on the knowledge and technical facilities available at TA Technology (Shanghai) Co., Ltd. at the time of execution of the test.

TA Technology (Shanghai) Co., Ltd. is liable to the client for the maintenance by its personnel of the confidentiality of all information related to the items under test and the results of the test. This report only refers to the item that has undergone the test.

The test results in this test report relate only to the devices specified in this report. This report shall not be reproduced except in full without the written approval of **TA Technology (Shanghai) Co., Ltd.**

If the electronic report is inconsistent with the printed one, it should be subject to the latter.

TA Technology (Shanghai) Co., Ltd.

Test Report

Report No.: RXA1507-0128RF03R3

Page 5 of 54

1.2. Testing laboratory

Company: TA Technology (Shanghai) Co., Ltd.
Address: No.145, Jintang Rd, Tangzhen Industry Park, Pudong
City: Shanghai
Post code: 201201
Country: P. R. China
Contact: Xu Kai
Telephone: +86-021-50791141/2/3
Fax: +86-021-50791141/2/3-8000
Website: <http://www.ta-shanghai.com>
E-mail: xukai@ta-shanghai.com

1.3. Applicant Information

Company: Mobilelock LLC
Address: 550M Ritchie Hwy, Severna Park / USA, 21146

1.4. Manufacturer Information

Company: Asiatelco Technologies Co
Address: #289 Bisheng Road, Building-8, 3F Zhangjiang Hi-Tech Park, Pudong, Shanghai
201204, PR.China

TA Technology (Shanghai) Co., Ltd.

Test Report

Report No.: RXA1507-0128RF03R3

Page 6 of 54

1.5. Information of EUT

General information

Product IMEI:	A10000323254E4
Hardware Version:	P1
Software Version:	DS600_VZW_2.1.4_20150825
Antenna Type:	Internal Antenna
Device Operating Configurations:	
Test Mode	Bluetooth(Low Energy)
Modulation Type:	GFSK
Packet Type:(Maximum Payload)	1Mbps
Max. Conducted Power	2.29dBm
Power Supply:	Battery or Charger (AC adaptor)
Operating Frequency Range(s)	2400 ~ 2483.5 MHz

Accessories information

Battery

Model: Dual OEM 18650H Battery
Capacity: 2 x 2.6 Ah
Manufacturer: UTL

Charger

Name: DEWALT
Model: ASSA1A-045200
Manufacturer: Aquil Star Precision Industrial

1.6. Test Date

The test is performed from August 20, 2015 to October 15, 2015.

2. Test Information

2.1. Test Mode

The EUT was programmed to be in continuously transmitting mode and the transmit duty cycle is not less than 98%.

During the process of the testing, The EUT is max power transmission with proper modulation.

EUT is stand-up position (Z axis), lie-down position (X, Y axis). The worst emission was found in stand-up position (Z axis) and the worst case was recorded.

Test Modes		
Band	Radiated Test Cases	Conducted Test Cases
Bluetooth(Low Energy)	Channel 0/19/39	Channel 0/19/39

Note: All modes of operation were investigated. The test results shown in the following sections represent the worst case emissions.

TA Technology (Shanghai) Co., Ltd.
Test Report

Report No.: RXA1507-0128RF03R3

Page 8 of 54

2.2. Summary of test results

Number	Summary of measurements of results	Clause in FCC rules	Verdict
1	Peak Power Output -Conducted	15.247(b)(3)	PASS
2	Occupied Bandwidth (6dB)	15.247(a)(2)	PASS
3	Band Edge Compliance	15.247(d)	PASS
4	Power Spectral Density	15.247(e)	PASS
5	Spurious Radiated Emissions in the restricted band	15.247(d),15.205,15.209	PASS
6	Spurious RF Conducted Emissions	15.247(d)	PASS
7	Radiates Emission	15.247(d),15.205,15.209	PASS
8	AC Power Line Conducted Emission	15.207	PASS

2.3. Peak Power Output –Conducted

Ambient condition

Temperature	Relative humidity	Pressure
23°C ~25°C	45%~50%	101.5kPa

Methods of Measurement

During the process of the testing, The EUT was connected to the spectrum analyzer with a known loss. The EUT is max power transmission with proper modulation. The peak detector is used. RBW is set to 2 MHz; VBW is set to 6 MHz. These measurements have been tested at following channels: 0, 19 and 39 of Bluetooth (Low Energy).

Test Setup

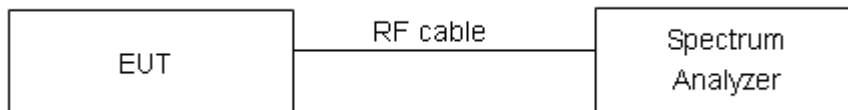

Limits

Rule Part 15.247 (b) (3) specifies that " For systems using digital modulation in the 902–928 MHz, 2400–2483.5 MHz, and 5725–5850 MHz bands: 1 Watt."

Peak Output Power	$\leq 1W$ (30dBm)
-------------------	-------------------

Measurement Uncertainty

The assessed measurement uncertainty to ensure 95% confidence level for the normal distribution is with the coverage factor $k = 2$, $U = 0.44$ dB.

TA Technology (Shanghai) Co., Ltd. Test Report

Test Results

Bluetooth (Low Energy)

Channel	Frequency (MHz)	Peak Output Power (dBm)	Conclusion
		1Mbps	
0	2402	1.65	PASS
19	2440	1.81	PASS
39	2480	2.29	PASS

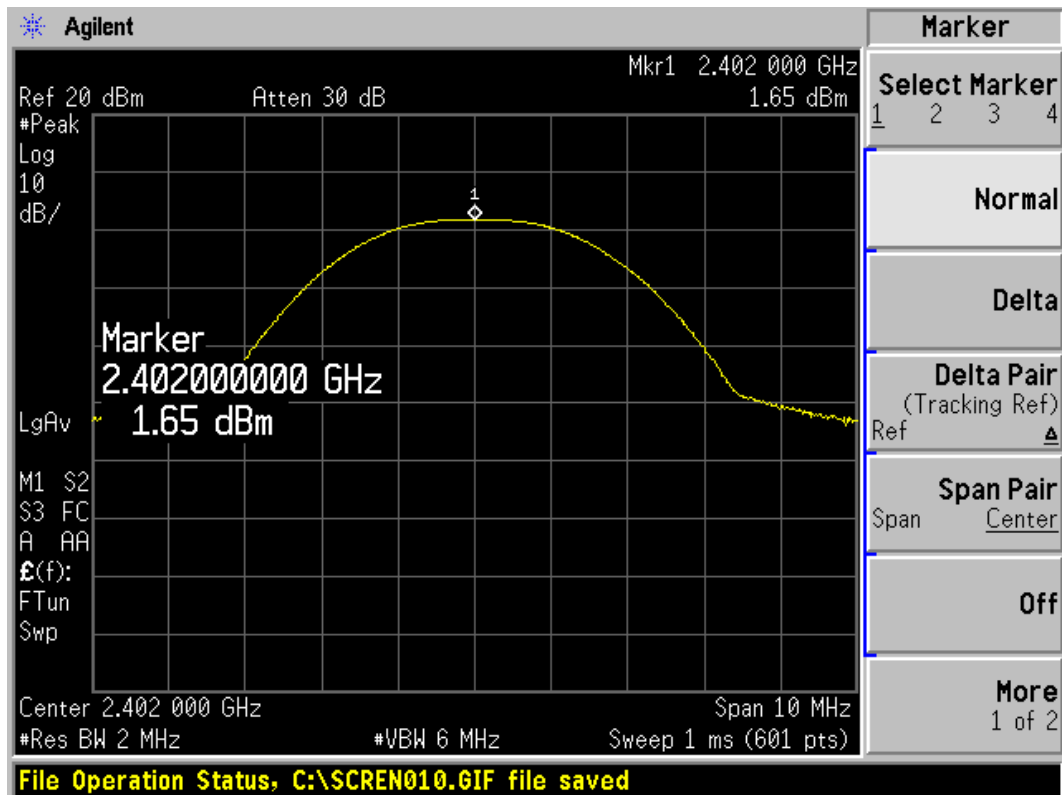

Carrier frequency (MHz): 2402

Channel No.:0

TA Technology (Shanghai) Co., Ltd. Test Report

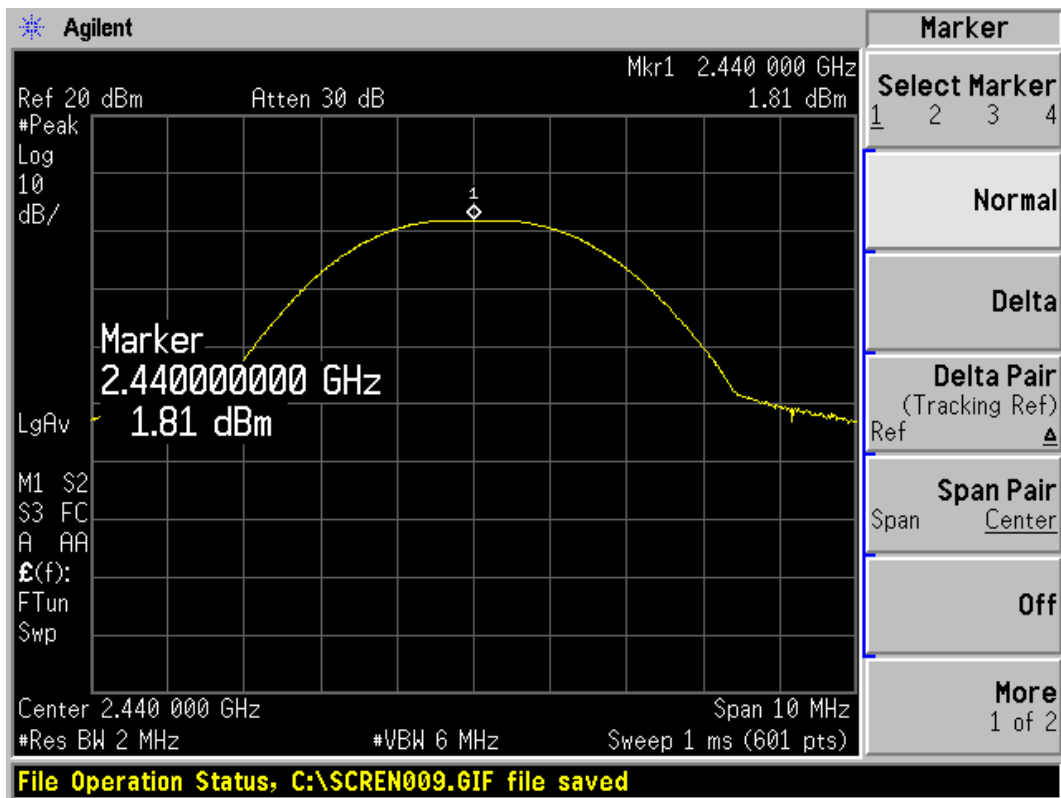

Carrier frequency (MHz): 2440
Channel No.:19

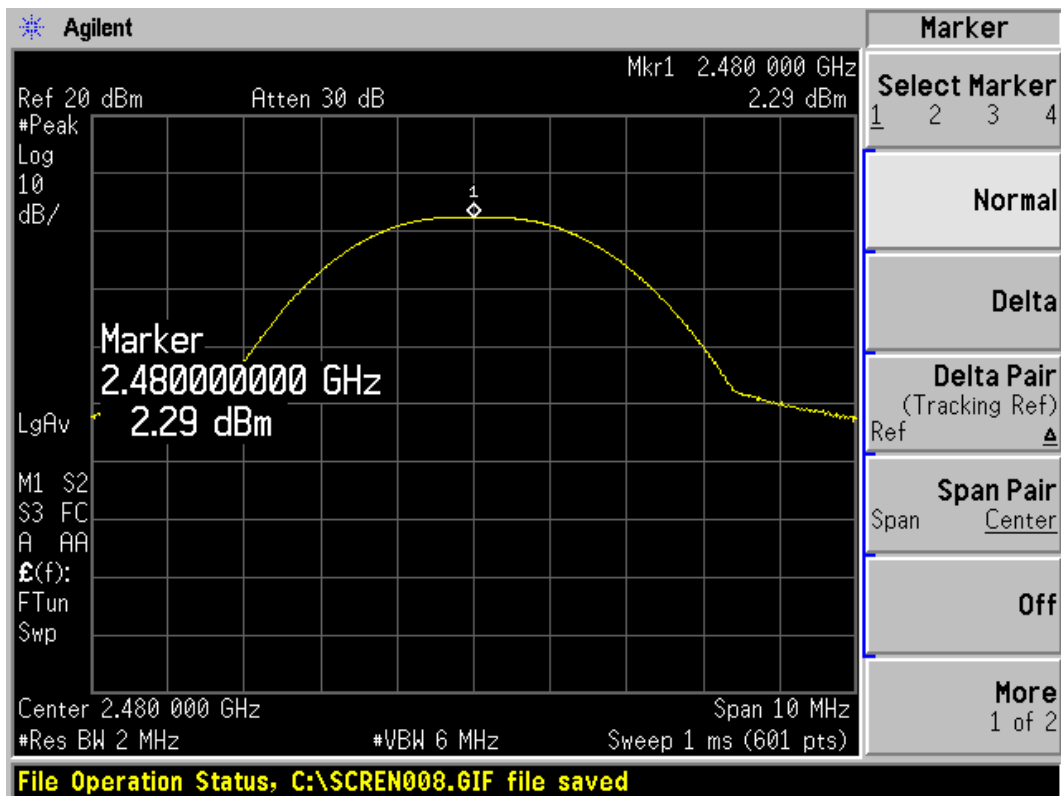

Carrier frequency (MHz): 2480
Channel No.:39

2.4. 6dB Occupied Bandwidth

Ambient condition

Temperature	Relative humidity	Pressure
23°C ~25°C	45%~50%	101.5kPa

Method of Measurement

The EUT was connected to the spectrum analyzer with a known loss. The occupied bandwidth is measured using spectrum analyzer. RBW is set to 100 kHz, VBW is set to 300 kHz on spectrum analyzer.

Test Setup

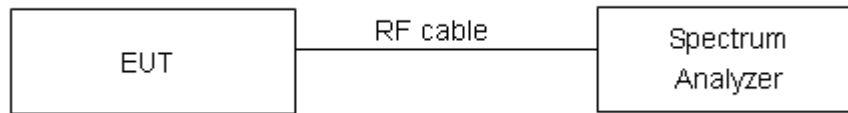

Limits

Rule Part 15.247 (a) (2) specifies that “Systems using digital modulation techniques may operate in the 902–928 MHz, 2400–2483.5 MHz, and 5725–5850 MHz bands. The minimum 6 dB bandwidth shall be at least 500 kHz.”

minimum 6 dB bandwidth	≥ 500 kHz
------------------------	-----------

Measurement Uncertainty

The assessed measurement uncertainty to ensure 95% confidence level for the normal distribution is with the coverage factor $k = 2$, $U = 936$ Hz.

TA Technology (Shanghai) Co., Ltd. Test Report

Test Results:

Bluetooth (Low Energy)

Channel	Frequency (MHz)	6dB Bandwidth (kHz)
0	2402	694.868
19	2440	716.010
39	2480	707.289

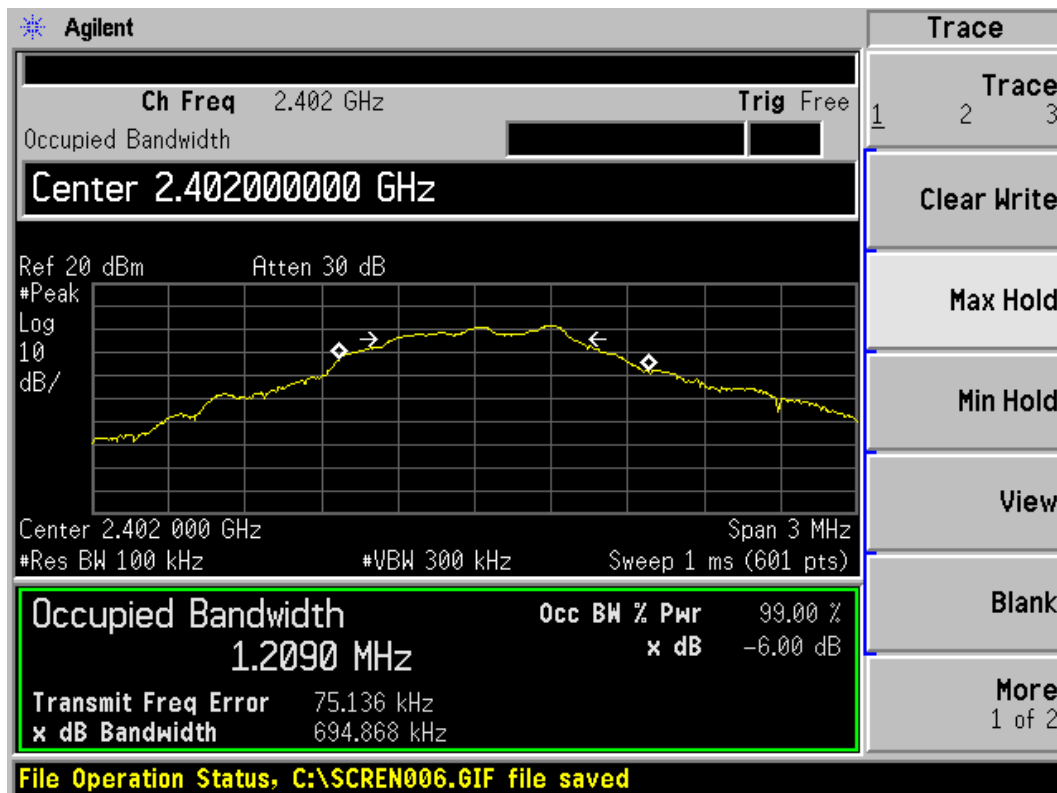

Carrier frequency (MHz): 2402

Channel No.:0

2.5. Band Edge Compliance

Ambient condition

Temperature	Relative humidity	Pressure
23°C ~25°C	45%~50%	101.5kPa

Method of Measurement

The EUT was connected to the spectrum analyzer with a known loss. The lowest and highest channels were measured. The peak detector is used. RBW is set to 100 kHz and VBW is set to 300 kHz on spectrum analyzer.

Test Setup

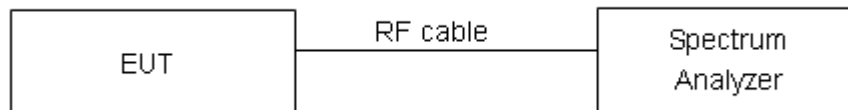

Limits

Rule Part 15.247(d) specifies that “In any 100 kHz bandwidth outside the frequency band in which the spread spectrum or digitally modulated intentional radiator is operating, the radio frequency power that is produced by the intentional radiator shall be at least 20 dB below that in the 100 kHz bandwidth within the band that contains the highest level of the desired power, based on either an RF conducted or a radiated measurement, provided the transmitter demonstrates compliance with the peak conducted power limits.”

Measurement Uncertainty

The assessed measurement uncertainty to ensure 95% confidence level for the normal distribution is with the coverage factor $k = 1.96$.

TA Technology (Shanghai) Co., Ltd. Test Report

Test Results: PASS
Low Energy

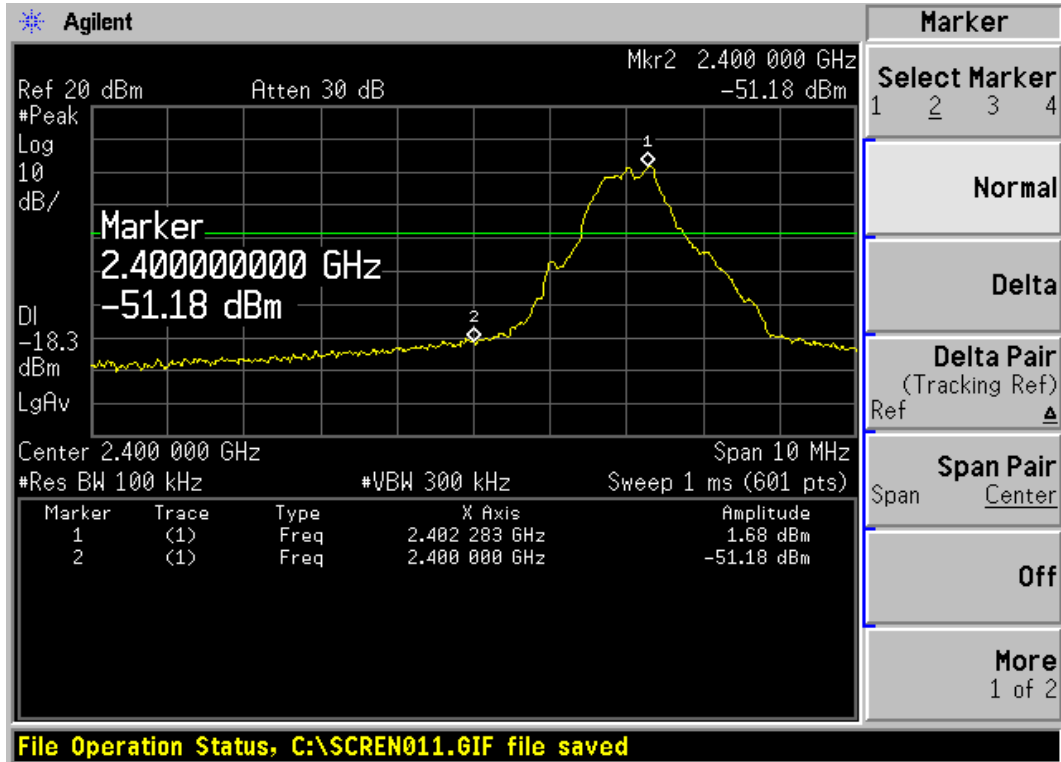

Carrier frequency (MHz): 2402
Channel No.:0

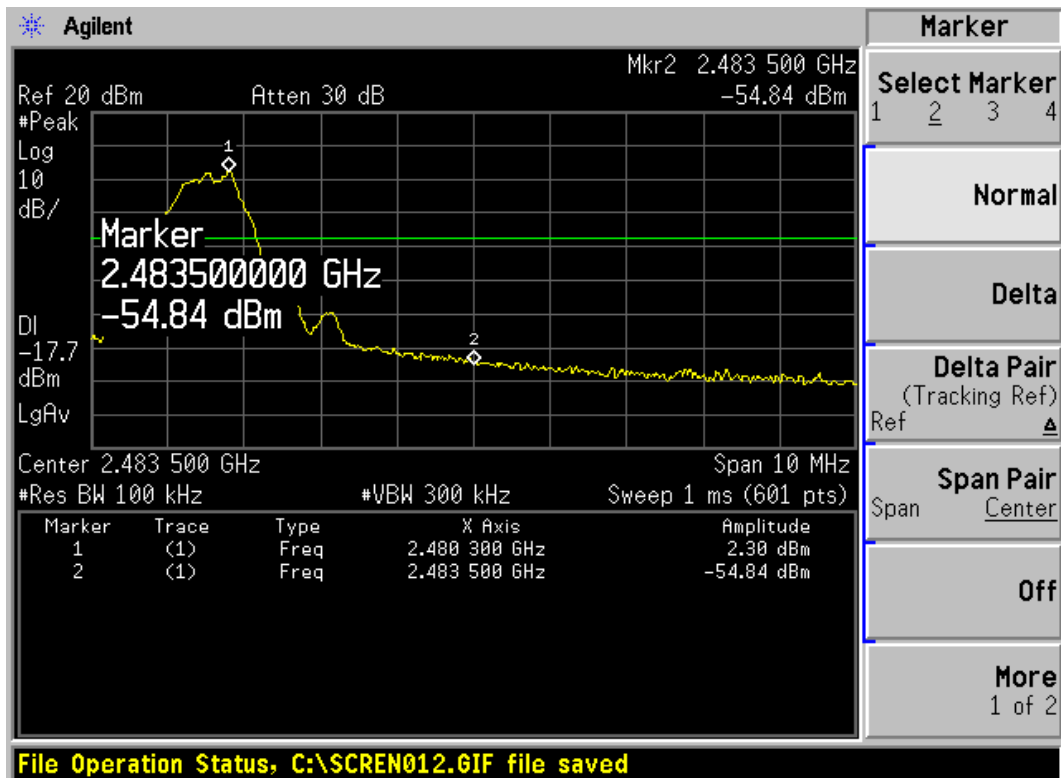

Carrier frequency (MHz): 2480
Channel No.:39

2.6. Power Spectral Density

Ambient condition

Temperature	Relative humidity	Pressure
23°C ~25°C	45%~50%	101.5kPa

Method of Measurement

The EUT was connected to the spectrum analyzer with a known loss.

RBW is set to 3 kHz and VBW is set to 10 kHz on spectrum analyzer. Set the span to 1.5 times the DTS channel bandwidth. Sweep time = auto couple. Trace mode = max hold.

The peak power spectral density is recorded.

Test setup

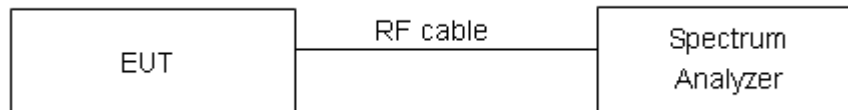

Limits

Rule Part 15.247(e) specifies that " For digitally modulated systems, the power spectral density conducted from the intentional radiator to the antenna shall not be greater than 8 dBm in any 3 kHz band during any time interval of continuous transmission. "

Limits	$\leq 8 \text{ dBm} / 3\text{kHz}$
--------	------------------------------------

Measurement Uncertainty

The assessed measurement uncertainty to ensure 95% confidence level for the normal distribution is with the coverage factor $k = 2$, $U = 0.75\text{dB}$.

TA Technology (Shanghai) Co., Ltd. Test Report

Test Results:

Bluetooth (Low Energy)

Channel Number	Power Spectral Density dBm / 3kHz	Conclusion
0	-7.12	PASS
19	-6.85	PASS
39	-6.70	PASS

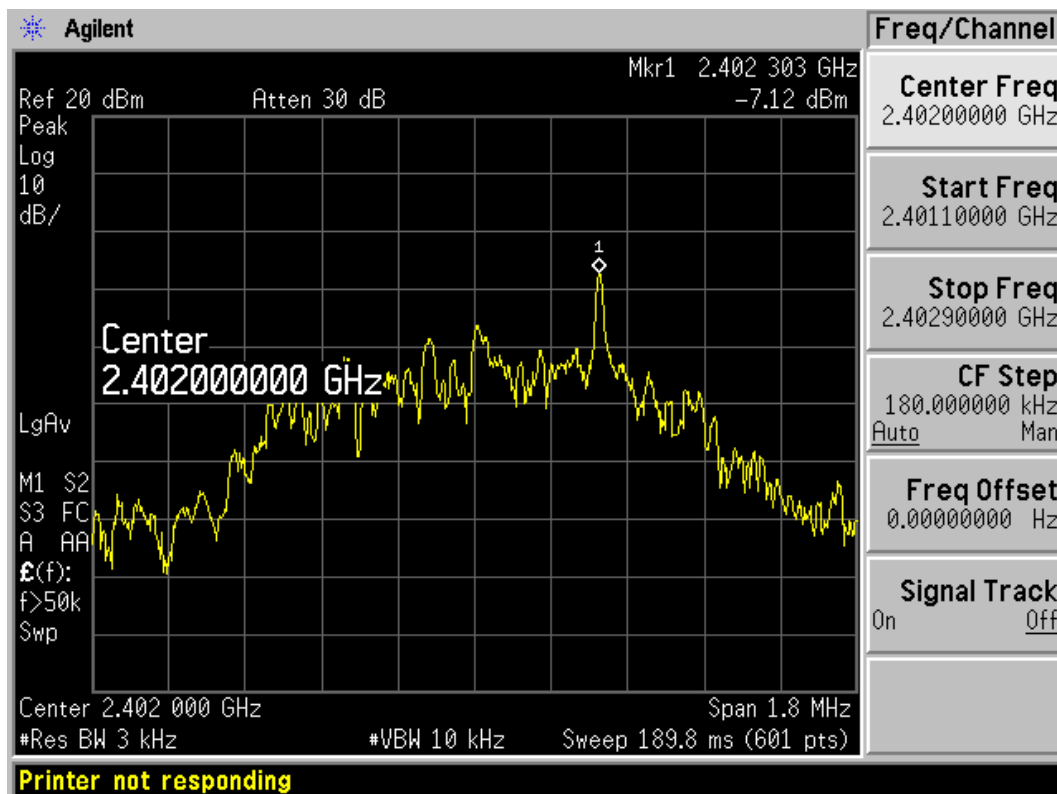

Low energy, Channel No.: 0

TA Technology (Shanghai) Co., Ltd. Test Report

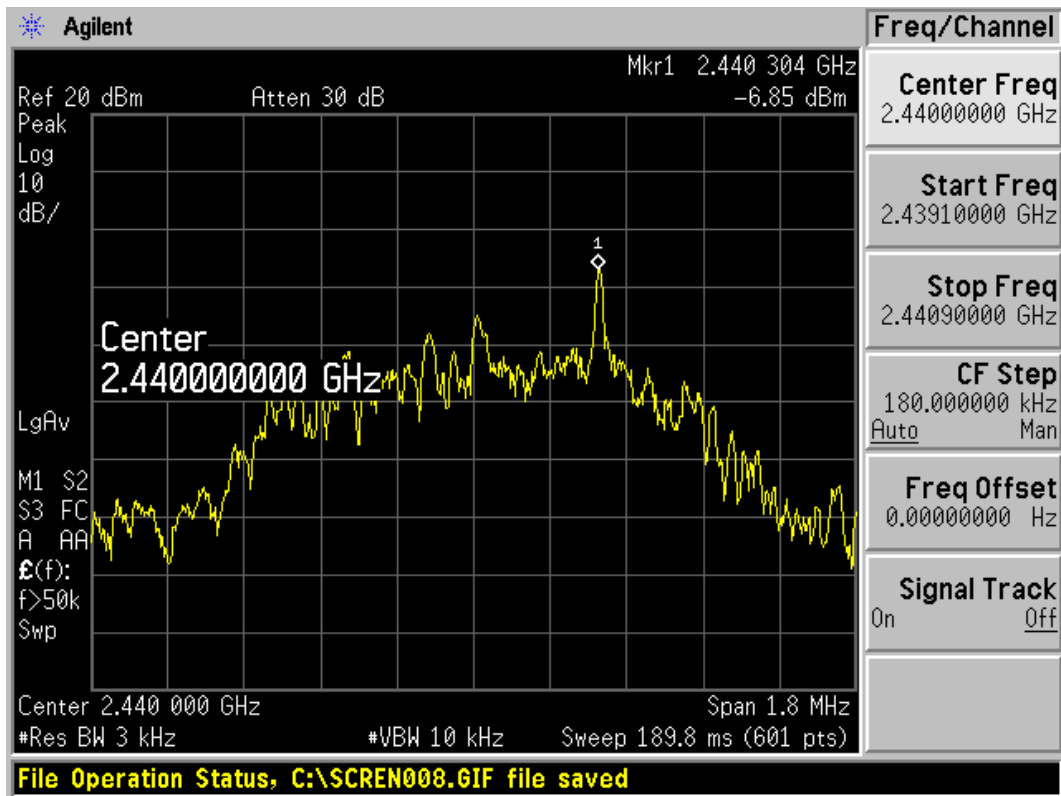

Low energy, Channel No.: 19

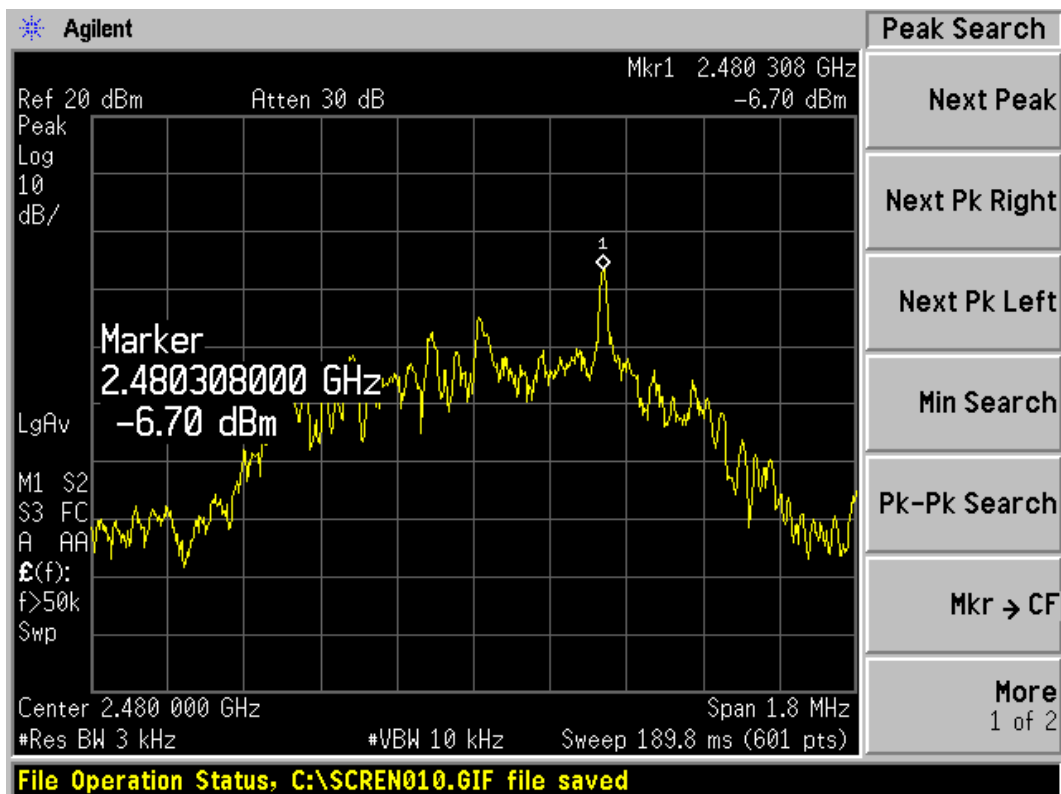

Low energy, Channel No.: 39

2.7. Spurious Radiated Emissions in the Restricted Band

Ambient condition

Temperature	Relative humidity	Pressure
23°C ~25°C	45%~50%	101.5kPa

Method of Measurement

The Equipment Under Test (EUT) was set up on a non-conductive table in the semi-anechoic chamber. The test was performed at the distance of 3 m between the EUT and the receiving antenna. The turntable shall be rotated from 0 to 360 degrees for detecting the maximum of radiated spurious signal level. The measurements shall be repeated with orthogonal polarization of the test antenna. The data of cable loss and antenna factor has been calibrated in full testing frequency range before the testing.

Set the spectrum analyzer in the following:

(a) PEAK: RBW=VBW=1MHz / Sweep=AUTO

(b) The dwell time per channel of the hopping signal is less than 100 ms, then the reading obtained with the 10 Hz VBW may be further adjusted by a “duty cycle correction factor”, derived from $20\log(\text{dwell time}/100 \text{ ms})$, in an effort to demonstrate compliance with the 15.209 limit.

If the emission is pulsed, modify the unit for continuous operation; use the settings shown above, then correct the reading by subtracting the peak- average correction factor, derived from the appropriate duty cycle calculation.

This setting method can refer to KDB 558074.

Test setup

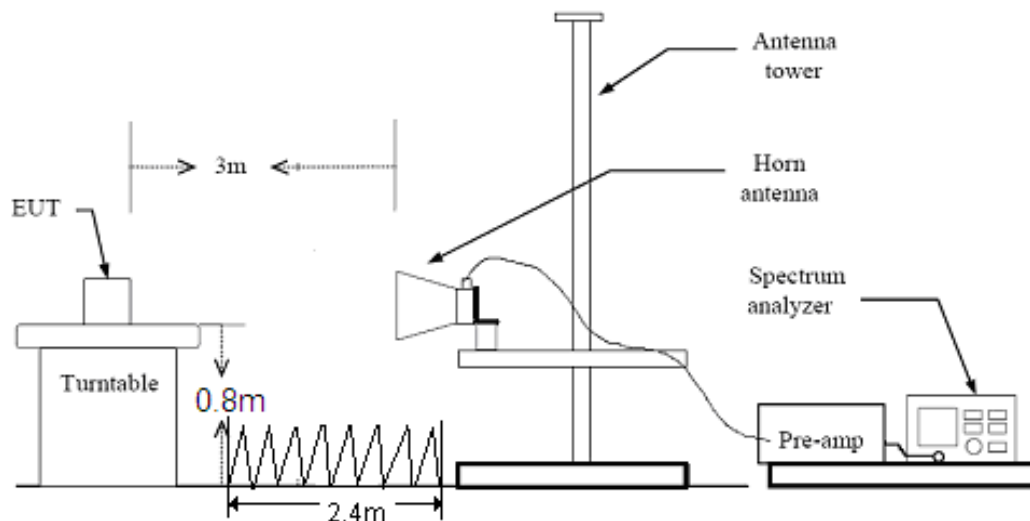

Note: Area side: 2.4mX3.6m

Limits

Spurious Radiated Emissions are permitted in any of the frequency bands listed below:

TA Technology (Shanghai) Co., Ltd. Test Report

MHz	MHz	MHz	GHz
0.090 - 0.110	16.42 - 16.423	399.9 - 410	4.5 - 5.15
¹ 0.495 - 0.505	16.69475 - 16.69525	608 - 614	5.35 - 5.46
2.1735 - 2.1905	16.80425 - 16.80475	960 - 1240	7.25 - 7.75
4.125 - 4.128	25.5 - 25.67	1300 - 1427	8.025 - 8.5
4.17725 - 4.17775	37.5 - 38.25	1435 - 1626.5	9.0 - 9.2
4.20725 - 4.20775	73 - 74.6	1645.5 - 1646.5	9.3 - 9.5
6.215 - 6.218	74.8 - 75.2	1660 - 1710	10.6 - 12.7
6.26775 - 6.26825	108 - 121.94	1718.8 - 1722.2	13.25 - 13.4
6.31175 - 6.31225	123 - 138	2200 - 2300	14.47 - 14.5
8.291 - 8.294	149.9 - 150.05	2310 - 2390	15.35 - 16.2
8.362 - 8.366	156.52475 - 156.52525	2483.5 - 2500	17.7 - 21.4
8.37625 - 8.38675	156.7 - 156.9	2690 - 2900	22.01 - 23.12
8.41425 - 8.41475	162.0125 - 167.17	3260 - 3267	23.6 - 24.0
12.29 - 12.293	167.72 - 173.2	3332 - 3339	31.2 - 31.8
12.51975 - 12.52025	240 - 285	3345.8 - 3358	36.43 - 36.5
12.57675 - 12.57725	322 - 335.4	3600 - 4400	(²)
13.36 - 13.41			

Limit in restricted band

Frequency of emission (MHz)	Field strength(uV/m)	Field strength(dBuV/m)
30-88	100	40
88-216	150	43.5
216-960	200	46
Above960	500	54

§15.35(b)

There is also a limit on the radio frequency emissions, as measured using instrumentation with a peak detector function, corresponding to 20 dB above the maximum permitted average limit.

Peak Limit=74 dBuV/m

Average Limit=54 dBuV/m

Measurement Uncertainty

The assessed measurement uncertainty to ensure 95% confidence level for the normal distribution is with the coverage factor $k = 1.96$, $U = 3.55$ dB.

Channel 0

Peak

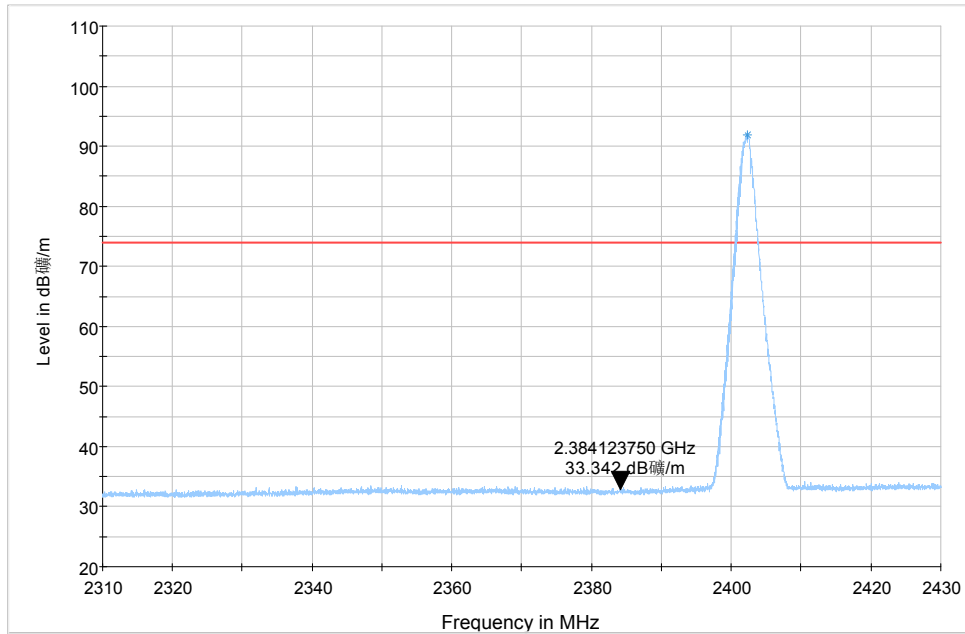

Note: This graph displays the maximum values of horizontal and vertical by software
Note: The signal beyond the limit is carrier, a font (Level in dB μ V/m) in the test plot =(level in dBuV/m)

Average

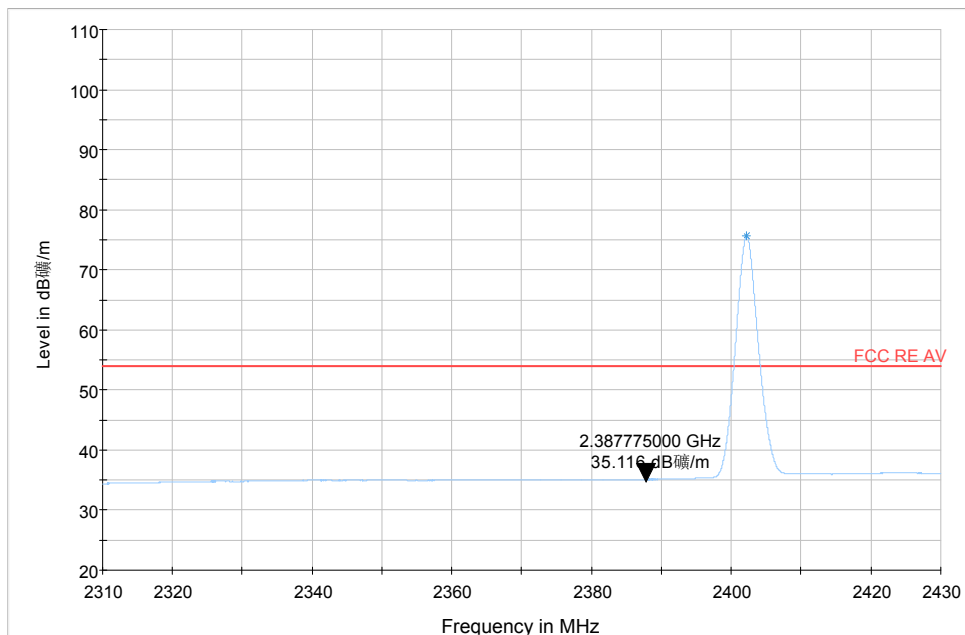

Note: This graph displays the maximum values of horizontal and vertical by software
Note: The signal beyond the limit is carrier, a font (Level in dB μ V/m) in the test plot =(level in dBuV/m)

Channel 39

Peak

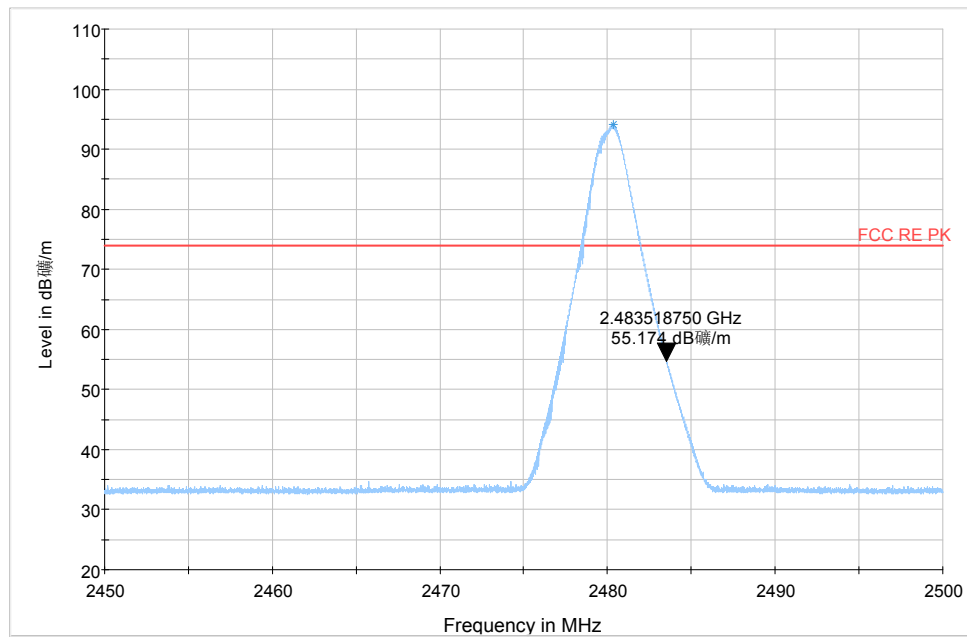

— FCC RE PK — Preview Result 1-PK+ * Data Reduction Result 1 [2]-PK+

Note: This graph displays the maximum values of horizontal and vertical by software
Note: The signal beyond the limit is carrier, a font (Level in dBμV/m) in the test plot =(level in dBuV/m)

Average

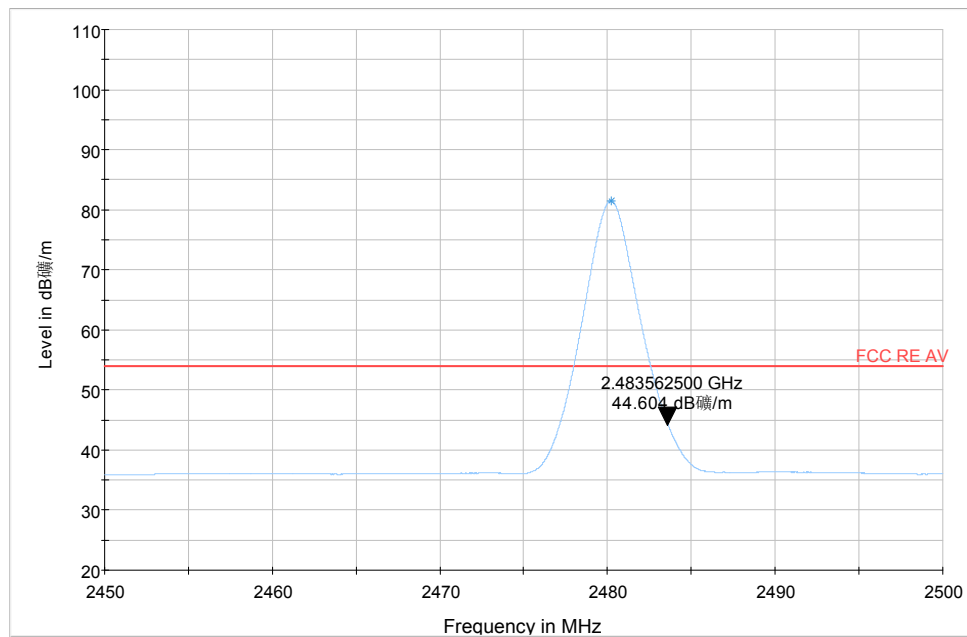

— FCC RE AV — Preview Result 1-AVG * Data Reduction Result 1 [2]-AVG

Note: This graph displays the maximum values of horizontal and vertical by software
Note: The signal beyond the limit is carrier, a font (Level in dBμV/m) in the test plot =(level in dBuV/m)

TA Technology (Shanghai) Co., Ltd.

Test Report

2.8. Spurious RF Conducted Emissions

Ambient condition

Temperature	Relative humidity	Pressure
23°C ~25°C	45%~50%	101.5kPa

Method of Measurement

The EUT was connected to the spectrum analyzer with a known loss. The spectrum analyzer scans from 30MHz to the 10th harmonic of the carrier. The peak detector is used. RBW and VBW are set to 100 kHz, Sweep is set to ATUO.

The test is in transmitting mode.

Test setup

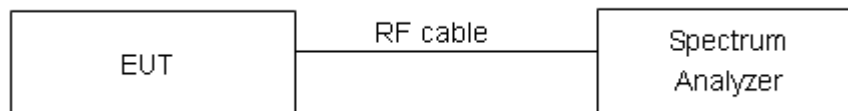

Limits

Rule Part 15.247(d) pacifies that “In any 100 kHz bandwidth outside the frequency band in which the spread spectrum intentional radiator is operating, the radio frequency power that is produced by the intentional radiator shall be at least 20 dB below that in the 100 kHz bandwidth within the band that contains the highest level of the desired power.”

Mode	Carrier frequency (MHz)	Reference value (dBm)	Limit
Bluetooth(Low Energy)	2402	5.14	≤-14.86
	2440	-2.47	≤-22.47
	2480	3.96	≤-16.04

Measurement Uncertainty

The assessed measurement uncertainty to ensure 95% confidence level for the normal distribution is with the coverage factor $k = 1.96$.

Frequency	Uncertainty
100kHz-2GHz	0.684 dB
2GHz-26GHz	1.407 dB

TA Technology (Shanghai) Co., Ltd.

Test Report

Test Results:

Bluetooth (Low Energy)

CH0:

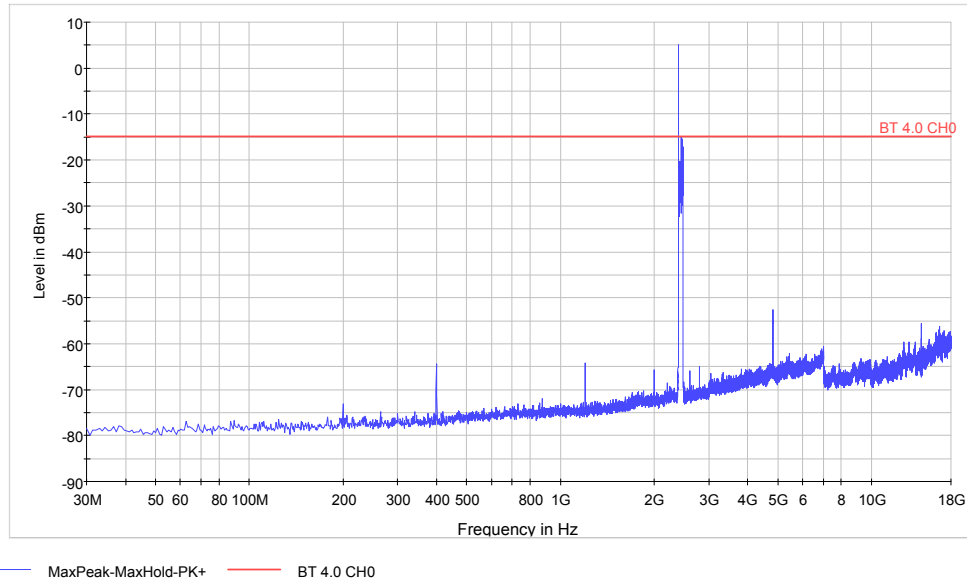

Note: The signal beyond the limit is carrier. Carrier frequency (MHz): 2402
 Spurious RF conducted emissions from 30MHz to 18GHz

Harmonic	Frequency (MHz)	Level (dBm)	Limit (dBm)	Margin (dB)
2	4804.5	-52.64	-14.86	37.78

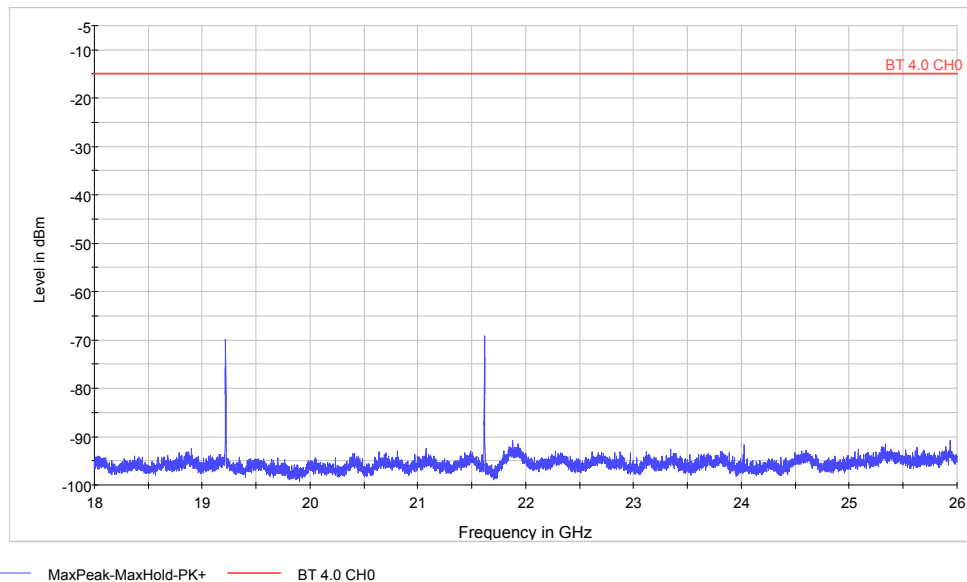

Spurious RF conducted emissions from 18GHz to 26.5GHz

Harmonic	Frequency (MHz)	Level (dBm)	Limit (dBm)	Margin (dB)
8	19218.0	-69.94	-14.86	55.08
9	21621.0	-69.13	-14.86	54.27

TA Technology (Shanghai) Co., Ltd. Test Report

CH19:

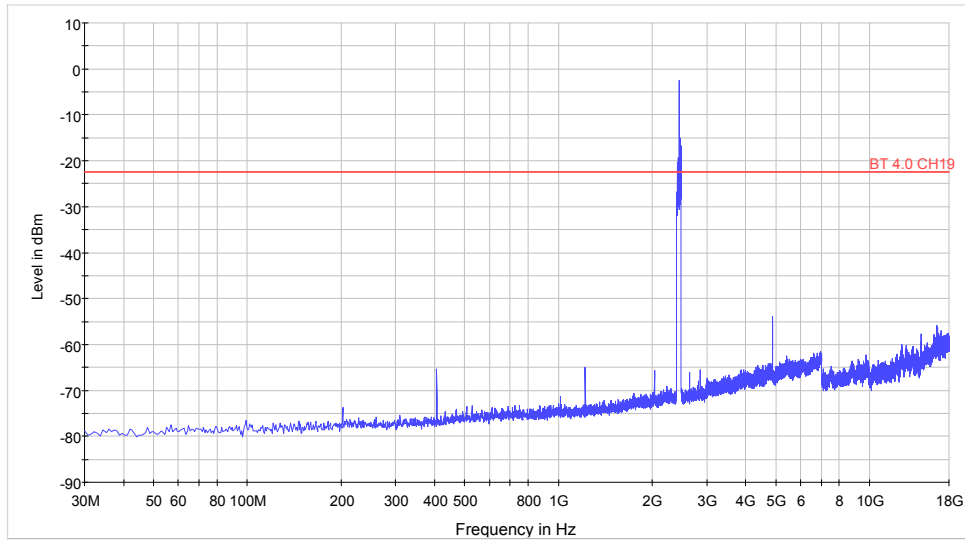

— MaxPeak-MaxHold-PK+ — BT 4.0 CH19

Note: The signal beyond the limit is carrier. Carrier frequency (MHz): 2440
Spurious RF conducted emissions from 30MHz to 18GHz

Harmonic	Frequency (MHz)	Level (dBm)	Limit (dBm)	Margin (dB)
2	4880.6	-53.95	-22.47	31.48

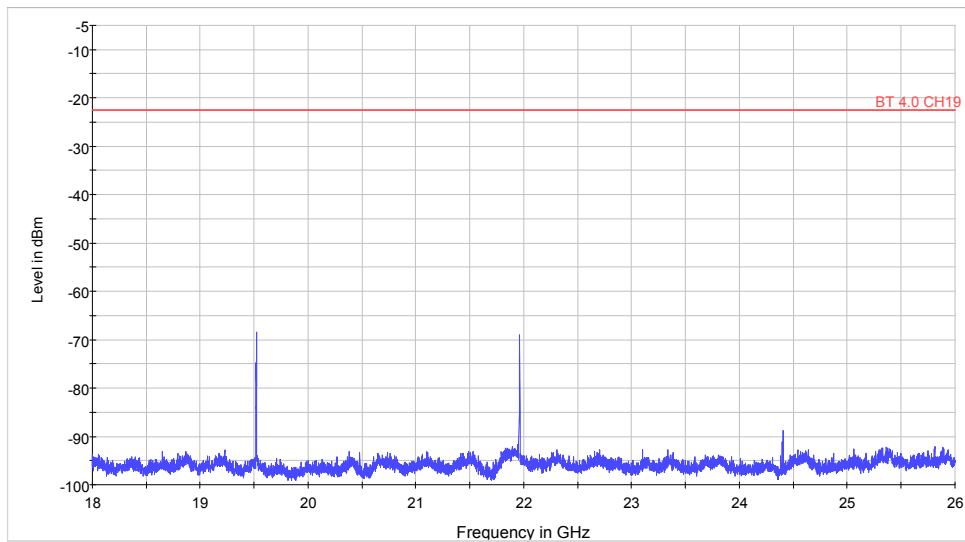

— MaxPeak-MaxHold-PK+ — BT 4.0 CH19

Spurious RF conducted emissions from 18GHz to 26.5GHz

Harmonic	Frequency (MHz)	Level (dBm)	Limit (dBm)	Margin (dB)
8	19522.0	-68.39	-22.47	45.92
9	21963.0	-68.97	-22.47	46.50
10	24403.0	-88.76	-22.47	66.29

TA Technology (Shanghai) Co., Ltd. Test Report

CH39:

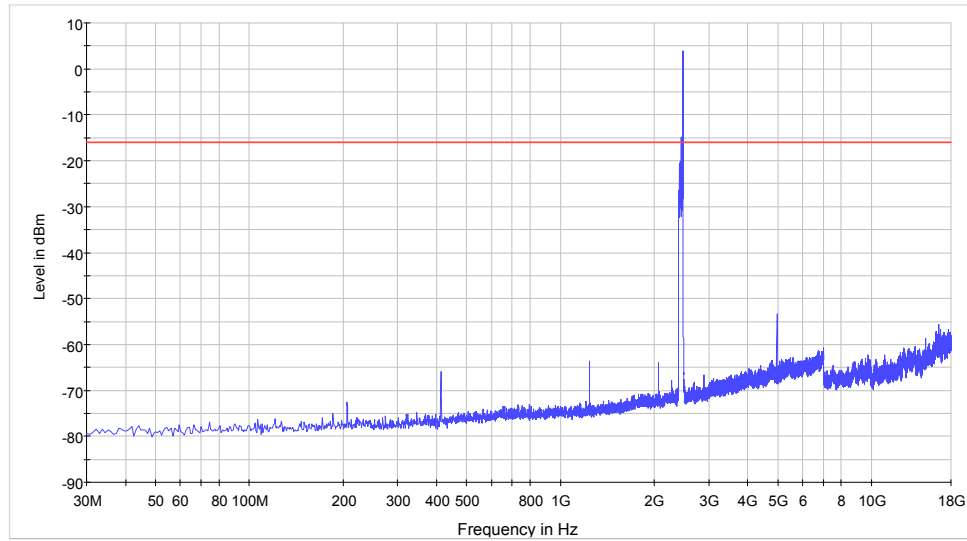

MaxPeak-MaxHold-PK+ BT 4.0 CH39

Note: The signal beyond the limit is carrier. Carrier frequency (MHz): 2480
Spurious RF conducted emissions from 30MHz to 18GHz

Harmonic	Frequency (MHz)	Level (dBm)	Limit (dBm)	Margin (dB)
2	4960.5	-53.30	-16.04	37.26

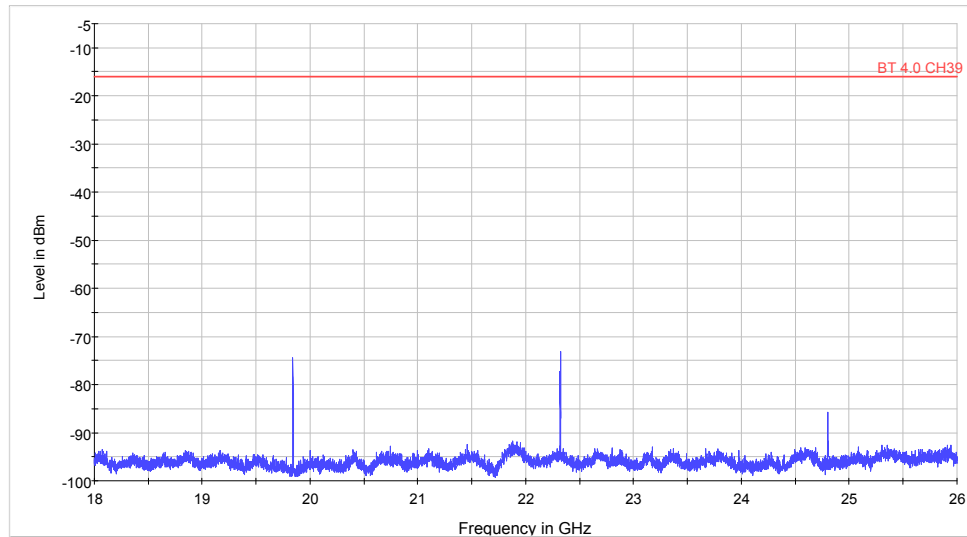

MaxPeak-MaxHold-PK+ BT 4.0 CH39

Spurious RF conducted emissions from 18GHz to 26.5GHz

Harmonic	Frequency (MHz)	Level (dBm)	Limit (dBm)	Margin (dB)
8	19842.0	-74.37	-16.04	58.32
9	22323.0	-73.15	-16.04	57.10
10	24803.0	-85.70	-16.04	69.66

2.9. Radiates Emission

Ambient condition

Temperature	Relative humidity	Pressure
23°C ~25°C	45%~50%	102.5kPa

Method of Measurement

The test set-up was made in accordance to the general provisions of ANSI C63.10-2013. The Equipment Under Test (EUT) was set up on a non-conductive table in the semi-anechoic chamber. The test was performed at the distance of 3 m between the EUT and the receiving antenna. The radiated emissions measurements were made in a typical installation configuration.

Sweep the whole frequency band through the range from 9 kHz to the 10th harmonic of the carrier, and the emissions less than 20 dB below the permissible value are reported.

During the test, below 30MHz, the center of the loop shall be 1 meters; above 30MHz, the height of receive antenna shall be moved from 1 to 4 meters, and the antenna shall be performed under horizontal and vertical polarization. The turntable shall be rotated from 0 to 360 degrees for detecting the maximum of radiated spurious signal level. The measurements shall be repeated with orthogonal polarization of the test antenna. The data of cable loss and antenna factor has been calibrated in full testing frequency range before the testing.

Set the spectrum analyzer in the following:

Below 1GHz (detector: Peak and Quasi-Peak)

RBW=100 kHz / VBW=300 kHz / Sweep=AUTO

Above 1GHz (detector: Peak):

(a) PEAK: RBW=1MHz VBW=3MHz/ Sweep=AUTO

(b) AVERAGE: RBW=1MHz / VBW=10Hz / Sweep=AUTO

The test is in transmitting mode.

TA Technology (Shanghai) Co., Ltd. Test Report

Test setup

9KHz~~~ 30MHz

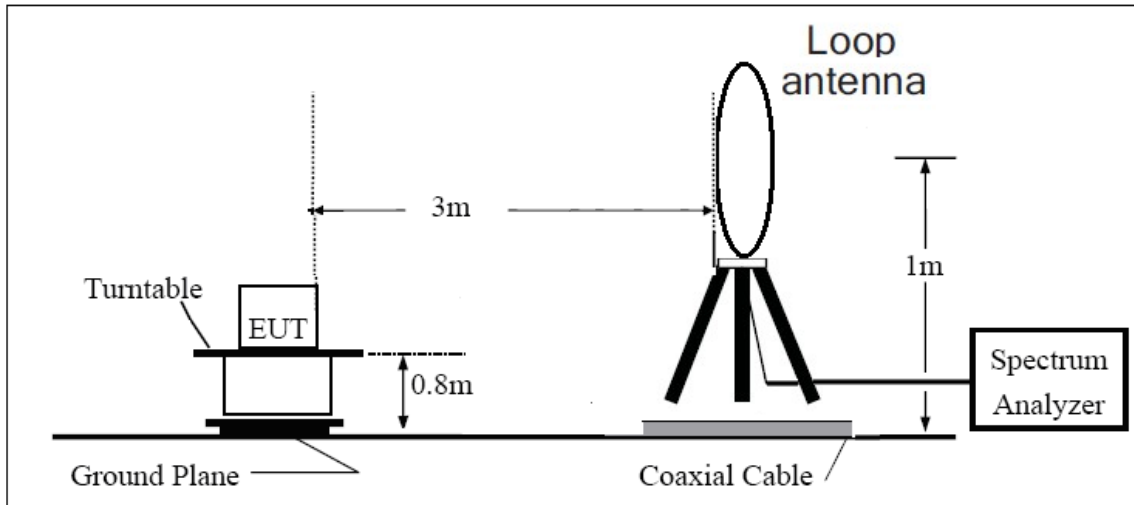

30MHz~~~ 1GHz

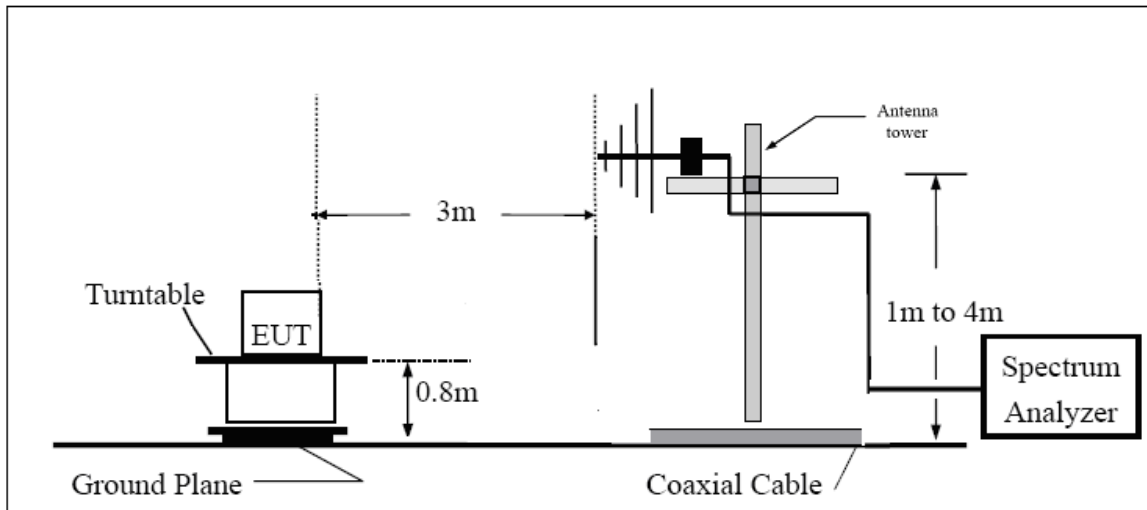

Above 1GHz

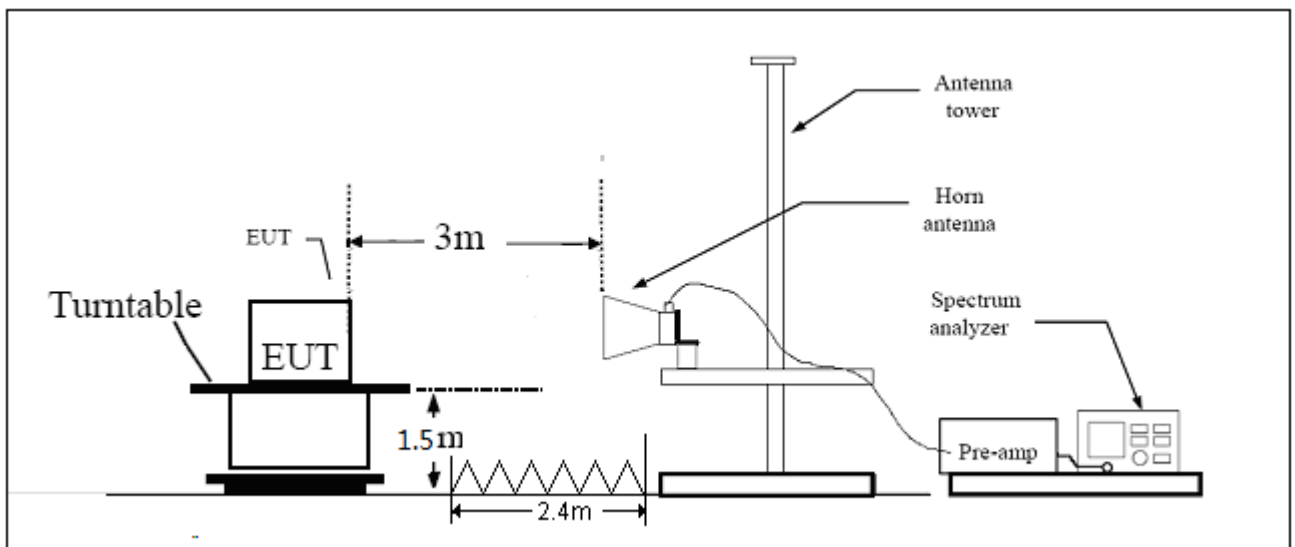

Note: Area side: 2.4mX3.6m

TA Technology (Shanghai) Co., Ltd.

Test Report

Report No.: RXA1507-0128RF03R3

Page 30 of 54

Limits

Rule Part 15.247(d) specifies that “In addition, radiated emissions which fall in the restricted bands, as defined in § 15.205(a), must also comply with the radiated emission limits specified in § 15.209(a) (see § 15.205(c)).”

Limit in restricted band

Frequency of emission (MHz)	Field strength(uV/m)	Field strength(dBuV/m)
0.009–0.490	2400/F(kHz)	/
0.490–1.705	24000/F(kHz)	/
1.705–30.0	30	/
30-88	100	40
88-216	150	43.5
216-960	200	46
Above960	500	54

§15.35(b)

There is also a limit on the radio frequency emissions, as measured using instrumentation with a peak detector function, corresponding to 20 dB above the maximum permitted average limit.

Measurement Uncertainty

The assessed measurement uncertainty to ensure 95% confidence level for the normal distribution is with the coverage factor $k = 1.96$.

Frequency	Uncertainty
9KHz-30MHz	3.55 dB
30MHz-200MHz	4.19 dB
200MHz-1GHz	3.63 dB
Above 1GHz	3.68 dB

TA Technology (Shanghai) Co., Ltd.

Test Report

Test result

Sweep from 9 kHz to 30MHz, and the emissions more than 20 dB below the permissible value are not reported.

CH0

FCC RE 0.03-1GHz QP Class C

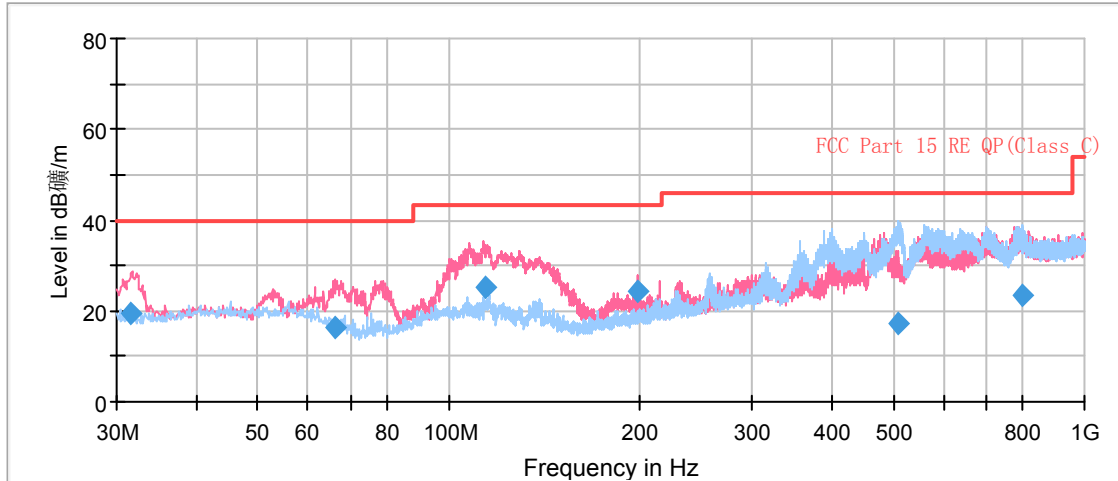

Note: This graph displays the maximum values of horizontal and vertical by software

Note: a font (Level in dB_{μV/m}) in the test plot =(level in dBuV/m)

Radiates Emission from 30MHz to 1GHz

Frequency (MHz)	Quasi-Peak (dBuV/m)	Height (cm)	Polarization	Azimuth (deg)	Reading value (dBuV/m)	Correct Factor (dB)	Margin (dB)	Limit (dBuV/m)
31.457500	19.4	100.0	V	247.0	31.3	-11.9	20.6	40.0
66.011250	16.2	100.0	V	115.0	26.3	-10.1	23.8	40.0
113.858750	25.1	100.0	V	0.0	36.7	-11.6	18.4	43.5
198.011250	24.4	100.0	V	119.0	36.3	-11.9	19.1	43.5
508.455000	17.3	100.0	H	16.0	37.4	-20.1	28.7	46.0
797.637500	23.4	100.0	H	22.0	47.7	-24.3	22.6	46.0

Remark: 1. Quasi-Peak = Reading value + Correction factor

2. Correction Factor = Antenna factor+ Insertion loss(cable loss+amplifier gain)

3. Margin = Limit – Quasi-Peak

TA Technology (Shanghai) Co., Ltd. Test Report

RE 1G-3GHz PK+AV

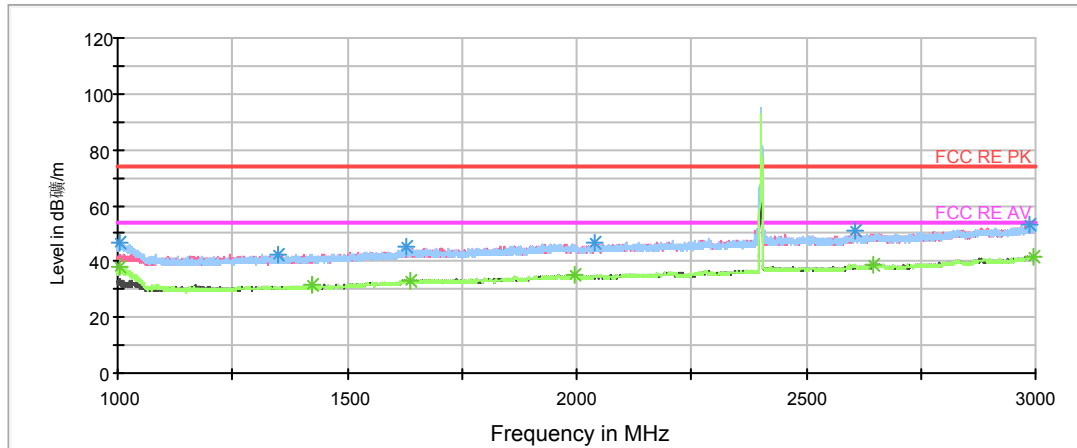

- FCC RE PK
- FCC RE AV
- Preview Result 1H-PK+
- Preview Result 2H-AVG
- * Data Reduction Result 1 [2]-PK+
- * Data Reduction Result 2 [2]-AVG

Note: This graph displays the maximum values of horizontal and vertical by software

Note: a font (Level in dBuV/m) in the test plot =(level in dBuV/m)

Note: The signal beyond the limit is carrier.

Radiates Emission from 1GHz to 3GHz

Frequency (MHz)	Peak (dBuV/m)	Height (cm)	Polarization	Azimuth (deg)	Reading value (dBuV/m)	Correct Factor (dB)	Margin (dB)	Limit (dBuV/m)
1003.250000	46.6	101.0	H	339.0	55.9	-9.3	27.4	74
1421.500000	40.9	101.0	H	0.0	47.8	-6.9	33.1	74
1639.500000	42.9	101.0	V	242.0	47.6	-4.7	31.1	74
1995.500000	44.4	101.0	V	283.0	47.6	-3.2	29.6	74
2648.000000	48.7	101.0	V	354.0	49.1	-0.4	25.3	74
2995.750000	50.8	101.0	H	221.0	53.1	-2.3	23.2	74

Frequency (MHz)	Average (dBuV/m)	Height (cm)	Polarization	Azimuth (deg)	Reading value (dBuV/m)	Correct Factor (dB)	Margin (dB)	Limit (dBuV/m)
1003.250000	38.0	101.0	H	339.0	47.3	-9.3	16.0	54
1421.500000	31.3	101.0	H	0.0	38.2	-6.9	22.7	54
1639.500000	33.4	101.0	V	242.0	38.1	-4.7	20.6	54
1995.500000	35.2	101.0	V	283.0	38.4	-3.2	18.8	54
2648.000000	38.7	101.0	V	354.0	39.1	-0.4	15.3	54
2995.750000	41.8	101.0	H	221.0	44.1	-2.3	12.2	54

TA Technology (Shanghai) Co., Ltd. Test Report

RE 3-18GHz PK+AV

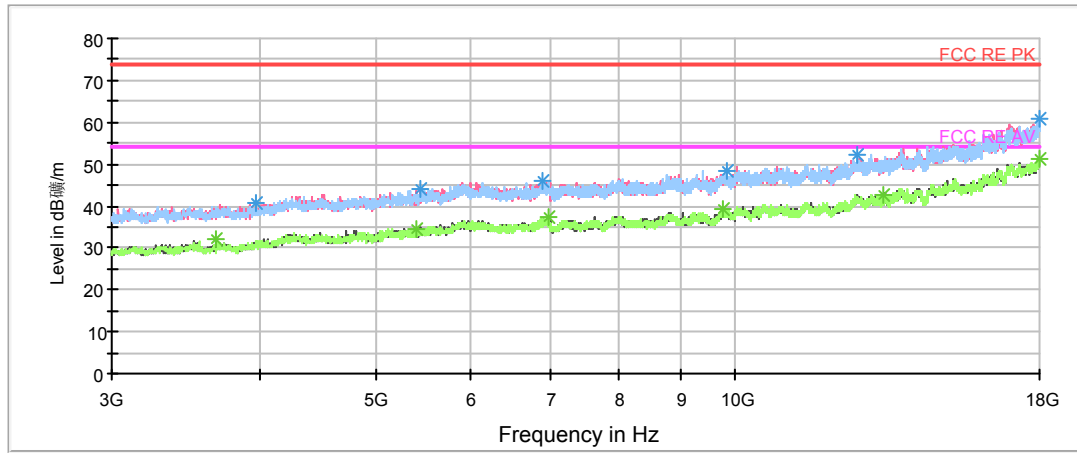

- FCC RE PK
- FCC RE AV
- Preview Result 1V-PK+
- Preview Result 2V-AVG
- Preview Result 1H-PK+
- Preview Result 2H-AVG
- * Data Reduction Result 1 [1]-PK+
- * Data Reduction Result 2 [1]-AVG

Note: This graph displays the maximum values of horizontal and vertical by software

Note: a font (Level in dBμV/m) in the test plot =(level in dBuV/m)

Radiates Emission from 3GHz to 18GHz

Frequency (MHz)	Peak (dBuV/m)	Height (cm)	Polarization	Azimuth (deg)	Reading value (dBuV/m)	Correct Factor (dB)	Margin (dB)	Limit (dBuV/m)
3675.000000	39.3	100.0	V	143.0	39.7	-0.4	34.7	74
5392.500000	40.5	100.0	V	37.0	44.2	-3.7	33.5	74
6984.375000	43.7	100.0	H	181.0	50.2	-6.5	30.3	74
9757.500000	46.0	100.0	V	334.0	57.7	-11.7	28.0	74
13335.000000	50.8	100.0	H	3.0	66.5	-15.7	23.2	74
17988.750000	59.8	100.0	V	62.0	85.1	-25.3	14.2	74

Frequency (MHz)	Average (dBuV/m)	Height (cm)	Polarization	Azimuth (deg)	Reading value (dBuV/m)	Correct Factor (dB)	Margin (dB)	Limit (dBuV/m)
3675.000000	32.2	100.0	V	143.0	32.6	-0.4	21.8	54
5392.500000	34.7	100.0	V	37.0	38.4	-3.7	19.3	54
6984.375000	37.2	100.0	H	181.0	43.7	-6.5	16.8	54
9757.500000	39.4	100.0	V	334.0	51.1	-11.7	14.6	54
13335.000000	42.8	100.0	H	3.0	58.5	-15.7	11.2	54
17988.750000	51.5	100.0	V	62.0	76.8	-25.3	2.5	54

TA Technology (Shanghai) Co., Ltd. Test Report

RE 18-26.5GHz PK+AV

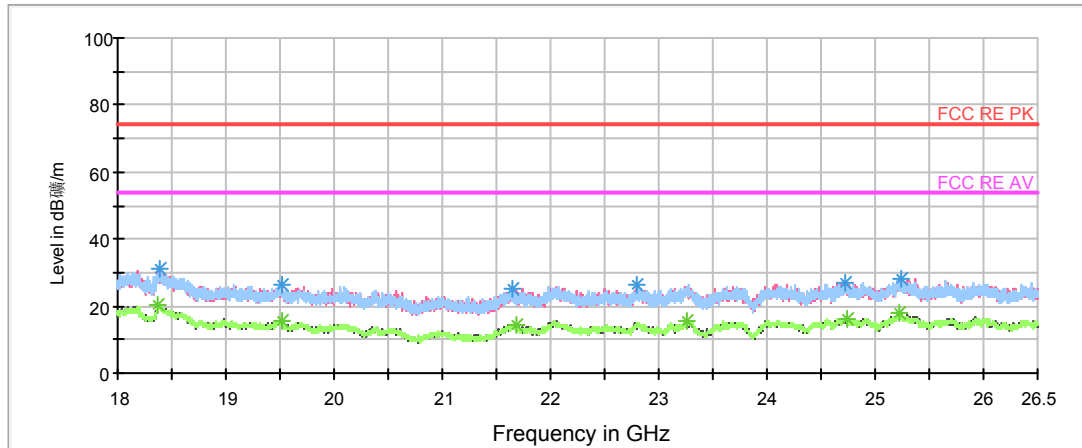

- FCC RE PK
- FCC RE AV
- Preview Result 1V-PK+
- * Data Reduction Result 1 [1]-PK+
- Preview Result 2V-AVG
- * Data Reduction Result 2 [1]-AVG
- Preview Result 1H-PK+
- Preview Result 2H-AVG

Note: This graph displays the maximum values of horizontal and vertical by software

Note: a font (Level in dBμV/m) in the test plot =(level in dBuV/m)

Note: The signal beyond the limit is carrier.

Radiates Emission from 18GHz to 26GHz

Frequency (MHz)	Peak (dBuV/m)	Polarization	Azimuth (deg)	Reading value (dBuV/m)	Correct Factor (dB)	Margin (dB)	Limit (dBuV/m)
18379.312500	29.2	H	0.0	34.0	-4.8	44.8	74
19509.812500	25.3	H	0.0	32.8	-7.5	48.7	74
21683.687500	23.3	H	0.0	32.7	-9.4	50.7	74
23251.937500	24.0	V	0.0	31.5	-7.5	50.0	74
24737.312500	25.1	H	0.0	31.5	-6.4	48.9	74
25223.937500	27.9	H	0.0	33.8	-5.9	46.1	74

Frequency (MHz)	Average (dBuV/m)	Polarization	Azimuth (deg)	Reading value (dBuV/m)	Correct Factor (dB)	Margin (dB)	Limit (dBuV/m)
18379.312500	20.2	H	0.0	25.0	-4.8	33.8	54
19509.812500	15.8	H	0.0	23.3	-7.5	38.2	54
21683.687500	14.6	H	0.0	24.0	-9.4	39.4	54
23251.937500	15.5	V	0.0	23.0	-7.5	38.5	54
24737.312500	16.4	H	0.0	22.8	-6.4	37.6	54
25223.937500	18.1	H	0.0	24.0	-5.9	35.9	54

TA Technology (Shanghai) Co., Ltd.

Test Report

CH19

FCC RE 0.03-1GHz QP Class C

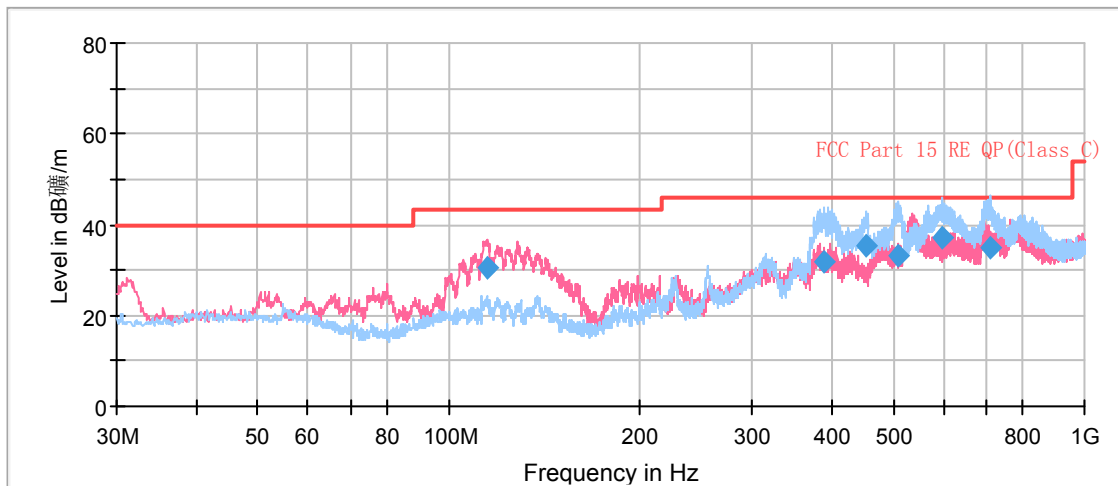

Note: This graph displays the maximum values of horizontal and vertical by software
 Note: a font (Level in dBuV/m) in the test plot =(level in dBuV/m)
 Radiates Emission from 30MHz to 1GHz

Frequency (MHz)	Quasi-Peak (dBuV/m)	Height (cm)	Polarization	Azimuth (deg)	Reading value (dBuV/m)	Correct Factor (dB)	Margin (dB)	Limit (dBuV/m)
114.913750	30.7	100.0	V	351.0	42.2	-11.5	12.8	43.5
389.510000	31.9	100.0	H	354.0	49.6	-17.7	14.1	46.0
452.480000	35.1	100.0	H	0.0	54.1	-19.0	10.9	46.0
510.312500	33.0	113.0	H	0.0	53.2	-20.2	13.0	46.0
596.031250	37.2	125.0	H	354.0	59.3	-22.1	8.8	46.0
708.635000	34.9	100.0	H	154.0	57.9	-23.0	11.1	46.0

- Remark: 1. Quasi-Peak = Reading value + Correction factor**
2. Correction Factor = Antenna factor+ Insertion loss(cable loss+amplifier gain)
3. Margin = Limit – Quasi-Peak

TA Technology (Shanghai) Co., Ltd. Test Report

RE 1G-3GHz PK+AV

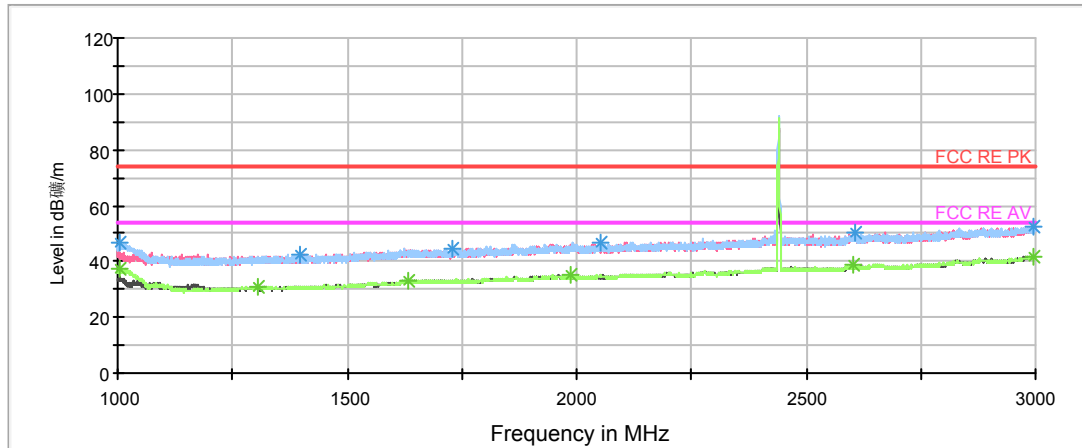

- FCC RE PK
- FCC RE AV
- Preview Result 1V-PK+
- Preview Result 2V-AVG
- Preview Result 1H-PK+
- Preview Result 2H-AVG
- * Data Reduction Result 1 [2]-PK+
- * Data Reduction Result 2 [2]-AVG

Note: This graph displays the maximum values of horizontal and vertical by software

Note: a font (Level in dBμV/m) in the test plot =(level in dBuV/m)

Note: The signal beyond the limit is carrier.

Radiates Emission from 1GHz to 3GHz

Frequency (MHz)	Peak (dBuV/m)	Height (cm)	Polarization	Azimuth (deg)	Reading value (dBuV/m)	Correct Factor (dB)	Margin (dB)	Limit (dBuV/m)
1004.250000	45.6	101.0	H	339.0	54.9	-9.3	28.4	74
1304.500000	40.4	101.0	V	217.0	48.2	-7.8	33.6	74
1633.500000	43.7	101.0	H	80.0	48.4	-4.7	30.3	74
1986.500000	43.9	101.0	H	134.0	47.6	-3.7	30.1	74
2604.500000	48.5	101.0	H	0.0	48.8	-0.3	25.5	74
2996.500000	51.6	101.0	H	134.0	53.9	-2.3	22.4	74

Frequency (MHz)	Average (dBuV/m)	Height (cm)	Polarization	Azimuth (deg)	Reading value (dBuV/m)	Correct Factor (dB)	Margin (dB)	Limit (dBuV/m)
1004.250000	37.3	101.0	H	339.0	46.6	-9.3	16.7	54
1304.500000	31.1	101.0	V	217.0	38.9	-7.8	22.9	54
1633.500000	33.4	101.0	H	80.0	38.1	-4.7	20.6	54
1986.500000	35.0	101.0	H	134.0	38.7	-3.7	19.0	54
2604.500000	38.7	101.0	H	0.0	39.0	-0.3	15.3	54
2996.500000	41.7	101.0	H	134.0	44.0	-2.3	12.3	54

TA Technology (Shanghai) Co., Ltd. Test Report

RE 3-18GHz PK+AV

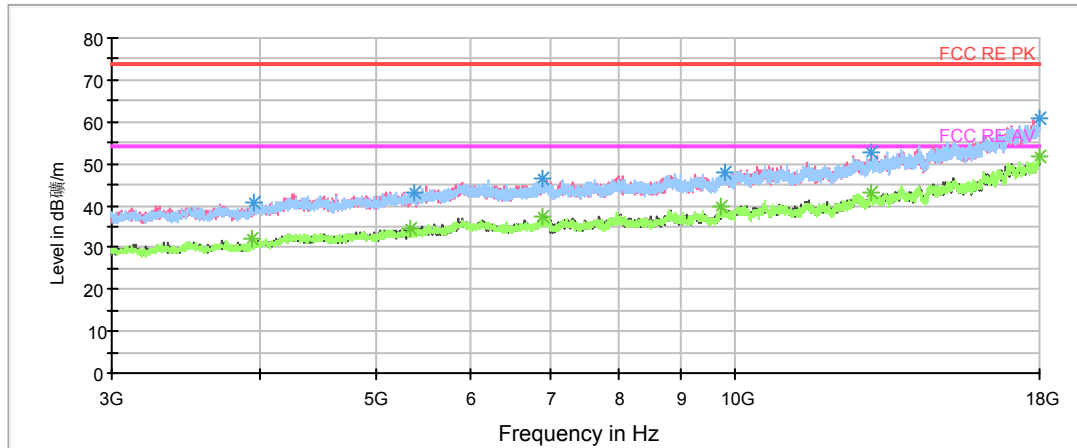

- FCC RE PK
- FCC RE AV
- Preview Result 1V-PK+
- * Data Reduction Result 1 [1]-PK+
- Preview Result 2V-AVG
- * Data Reduction Result 2 [1]-AVG
- Preview Result 1H-PK+
- Preview Result 2H-AVG

Note: This graph displays the maximum values of horizontal and vertical by software

Note: a font (Level in dBμV/m) in the test plot =(level in dBuV/m)

Radiates Emission from 3GHz to 18GHz

Frequency (MHz)	Peak (dBuV/m)	Height (cm)	Polarization	Azimuth (deg)	Reading value (dBuV/m)	Correct Factor (dB)	Margin (dB)	Limit (dBuV/m)
3931.875000	39.0	100.0	V	189.0	39.0	-0.0	35.0	74
5345.625000	41.8	100.0	H	184.0	45.6	-3.8	32.2	74
6901.875000	44.3	100.0	H	195.0	51.3	-7.0	29.7	74
9740.625000	45.9	100.0	H	0.0	57.4	-11.5	28.1	74
12988.125000	49.5	100.0	H	172.0	65.7	-16.2	24.5	74
17986.875000	58.8	100.0	V	345.0	84.0	-25.2	15.2	74

Frequency (MHz)	Average (dBuV/m)	Height (cm)	Polarization	Azimuth (deg)	Reading value (dBuV/m)	Correct Factor (dB)	Margin (dB)	Limit (dBuV/m)
3931.875000	31.9	100.0	V	189.0	31.9	-0.0	22.1	54
5345.625000	34.6	100.0	H	184.0	38.4	-3.8	19.4	54
6901.875000	37.2	100.0	H	195.0	44.2	-7.0	16.8	54
9740.625000	39.6	100.0	H	0.0	51.1	-11.5	14.4	54
12988.125000	43.1	100.0	H	172.0	59.3	-16.2	10.9	54
17986.875000	51.9	100.0	V	345.0	77.1	-25.2	2.1	54

TA Technology (Shanghai) Co., Ltd. Test Report

RE 18-26.5GHz PK+AV

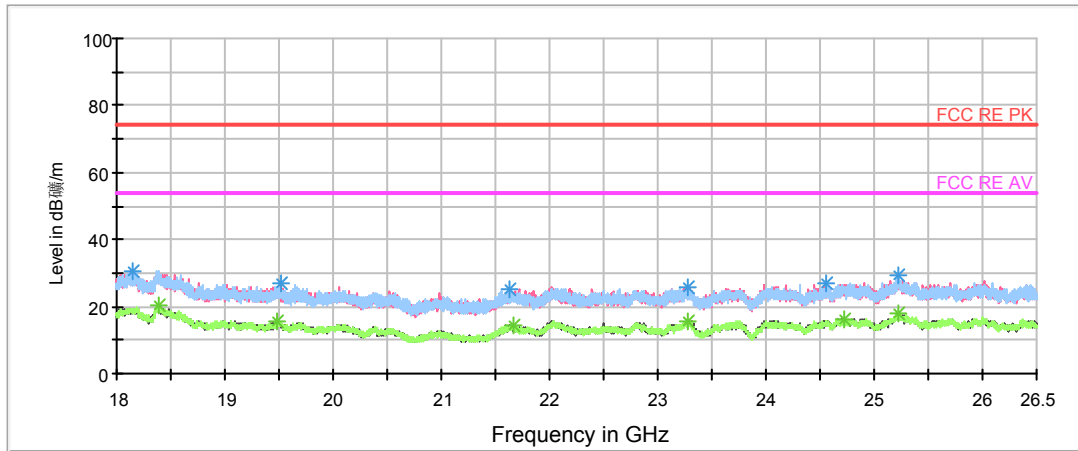

- FCC RE PK
- FCC RE AV
- Preview Result 1V-PK+
- Preview Result 2V-AVG
- Preview Result 1H-PK+
- Preview Result 2H-AVG
- * Data Reduction Result 1 [1]-PK+
- * Data Reduction Result 2 [1]-AVG

Note: This graph displays the maximum values of horizontal and vertical by software

Note: a font (Level in dBµV/m) in the test plot =(level in dBuV/m)

Note: The signal beyond the limit is carrier.

Radiates Emission from 18GHz to 26GHz

Frequency (MHz)	Peak (dBuV/m)	Polarization	Azimuth (deg)	Reading value (dBuV/m)	Correct Factor (dB)	Margin (dB)	Limit (dBuV/m)
18383.562500	29.0	V	0.0	33.8	-4.8	45.0	74
19482.187500	23.7	H	0.0	31.4	-7.7	50.3	74
21662.437500	23.6	H	0.0	32.9	-9.3	50.4	74
23279.562500	24.6	V	0.0	31.7	-7.1	49.4	74
24720.312500	23.5	V	0.0	29.8	-6.3	50.5	74
25221.812500	29.1	H	0.0	35.0	-5.9	44.9	74

Frequency (MHz)	Average (dBuV/m)	Polarization	Azimuth (deg)	Reading value (dBuV/m)	Correct Factor (dB)	Margin (dB)	Limit (dBuV/m)
18383.562500	20.1	V	0.0	24.9	-4.8	33.9	54
19482.187500	15.6	H	0.0	23.3	-7.7	38.4	54
21662.437500	14.6	H	0.0	23.9	-9.3	39.4	54
23279.562500	15.6	V	0.0	22.7	-7.1	38.4	54
24720.312500	16.3	V	0.0	22.6	-6.3	37.7	54
25221.812500	17.9	H	0.0	23.8	-5.9	36.1	54

TA Technology (Shanghai) Co., Ltd. Test Report

CH39

FCC RE 0.03-1GHz QP Class C

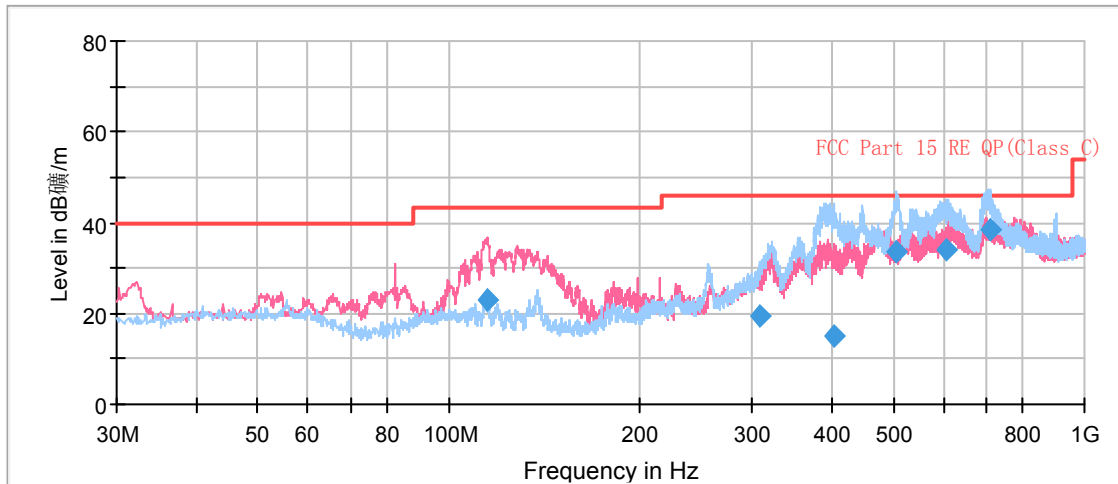

Note: This graph displays the maximum values of horizontal and vertical by software
 Note: a font (Level in dBµV/m) in the test plot =(level in dBuV/m)
 Radiates Emission from 30MHz to 1GHz

Frequency (MHz)	Quasi-Peak (dBuV/m)	Height (cm)	Polarization	Azimuth (deg)	Reading value (dBuV/m)	Correct Factor (dB)	Margin (dB)	Limit (dBuV/m)
114.597500	22.8	100.0	V	10.0	34.3	-11.5	20.7	43.5
309.557500	19.6	100.0	H	0.0	35.2	-15.6	26.4	46.0
402.846250	15.0	100.0	H	0.0	33.0	-18.0	31.0	46.0
506.146250	33.4	100.0	H	0.0	53.4	-20.0	12.6	46.0
604.961250	33.9	100.0	H	0.0	56.1	-22.2	12.1	46.0
708.876250	38.4	100.0	H	137.0	61.4	-23.0	7.6	46.0

- Remark: 1. Quasi-Peak = Reading value + Correction factor**
2. Correction Factor = Antenna factor+ Insertion loss(cable loss+amplifier gain)
3. Margin = Limit – Quasi-Peak

TA Technology (Shanghai) Co., Ltd. Test Report

RE 1G-3GHz PK+AV

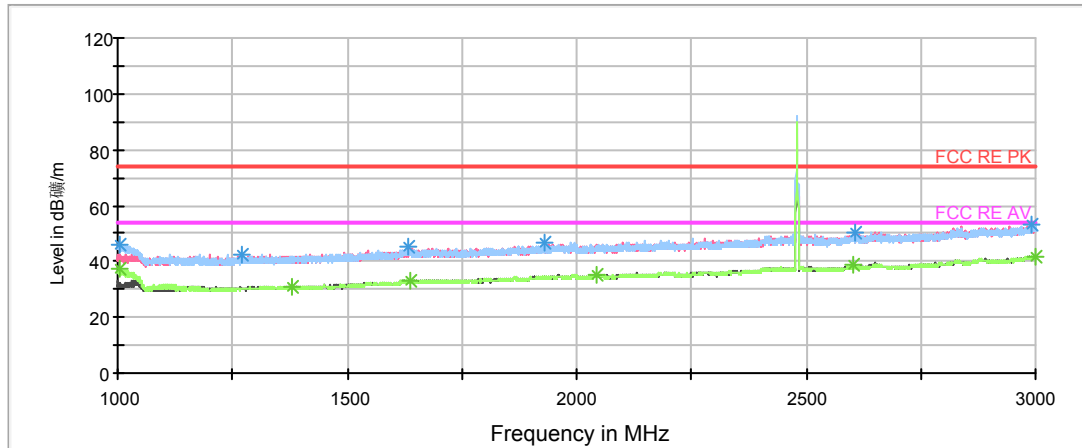

- FCC RE PK
- FCC RE AV
- Preview Result 1V-PK+
- Preview Result 2V-AVG
- Preview Result 1H-PK+
- Preview Result 2H-AVG
- * Data Reduction Result 1 [2]-PK+
- * Data Reduction Result 2 [2]-AVG

Note: This graph displays the maximum values of horizontal and vertical by software

Note: a font (Level in dBμV/m) in the test plot =(level in dBuV/m)

Note: The signal beyond the limit is carrier.

Radiates Emission from 1GHz to 3GHz

Frequency (MHz)	Peak (dBuV/m)	Height (cm)	Polarization	Azimuth (deg)	Reading value (dBuV/m)	Correct Factor (dB)	Margin (dB)	Limit (dBuV/m)
1004.250000	45.4	101.0	H	339.0	54.7	-9.3	28.6	74
1381.750000	40.7	101.0	V	83.0	47.7	-7.0	33.3	74
1636.250000	42.8	101.0	H	0.0	47.5	-4.7	31.2	74
2045.000000	44.6	101.0	H	83.0	47.8	-3.2	29.4	74
2601.250000	48.1	101.0	V	278.0	48.5	-0.4	25.9	74
2998.500000	50.8	101.0	V	284.0	53.1	-2.3	23.2	74

Frequency (MHz)	Average (dBuV/m)	Height (cm)	Polarization	Azimuth (deg)	Reading value (dBuV/m)	Correct Factor (dB)	Margin (dB)	Limit (dBuV/m)
1004.250000	37.2	101.0	H	339.0	46.5	-9.3	16.8	54
1381.750000	31.1	101.0	V	83.0	38.1	-7.0	22.9	54
1636.250000	33.4	101.0	H	0.0	38.1	-4.7	20.6	54
2045.000000	35.3	101.0	H	83.0	38.5	-3.2	18.7	54
2601.250000	38.7	101.0	V	278.0	39.1	-0.4	15.3	54
2998.500000	41.9	101.0	V	284.0	44.2	-2.3	12.1	54

TA Technology (Shanghai) Co., Ltd. Test Report

RE 3-18GHz PK+AV

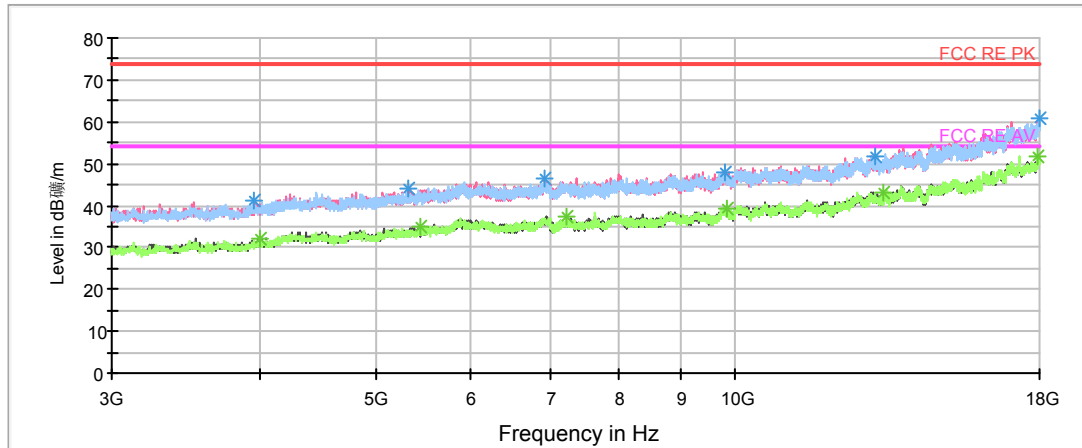

- FCC RE PK
— Preview Result 1V-PK+
— Preview Result 1H-PK+
* Data Reduction Result 1 [1]-PK+
- FCC RE AV
— Preview Result 2V-AVG
— Preview Result 2H-AVG
* Data Reduction Result 2 [1]-AVG

Note: This graph displays the maximum values of horizontal and vertical by software

Note: a font (Level in dBμV/m) in the test plot =(level in dBuV/m)

Radiates Emission from 3GHz to 18GHz

Frequency (MHz)	Peak (dBuV/m)	Height (cm)	Polarization	Azimuth (deg)	Reading value (dBuV/m)	Correct Factor (dB)	Margin (dB)	Limit (dBuV/m)
3999.375000	39.4	100.0	V	313.0	39.9	-0.5	34.6	74
5446.875000	43.1	100.0	V	52.0	46.9	-3.8	30.9	74
7213.125000	44.6	100.0	H	94.0	53.3	-8.7	29.4	74
9832.500000	46.8	100.0	V	167.0	58.7	-11.9	27.2	74
13335.000000	50.5	100.0	H	17.0	66.2	-15.7	23.5	74
17964.375000	57.8	100.0	H	275.0	82.8	-25.0	16.2	74

Frequency (MHz)	Average (dBuV/m)	Height (cm)	Polarization	Azimuth (deg)	Reading value (dBuV/m)	Correct Factor (dB)	Margin (dB)	Limit (dBuV/m)
3999.375000	32.3	100.0	V	313.0	32.8	-0.5	21.7	54
5446.875000	34.8	100.0	V	52.0	38.6	-3.8	19.2	54
7213.125000	37.4	100.0	H	94.0	46.1	-8.7	16.6	54
9832.500000	39.4	100.0	V	167.0	51.3	-11.9	14.6	54
13335.000000	43.2	100.0	H	17.0	58.9	-15.7	10.8	54
17964.375000	51.7	100.0	H	275.0	76.7	-25.0	2.3	54

TA Technology (Shanghai) Co., Ltd. Test Report

RE 18-26.5GHz PK+AV

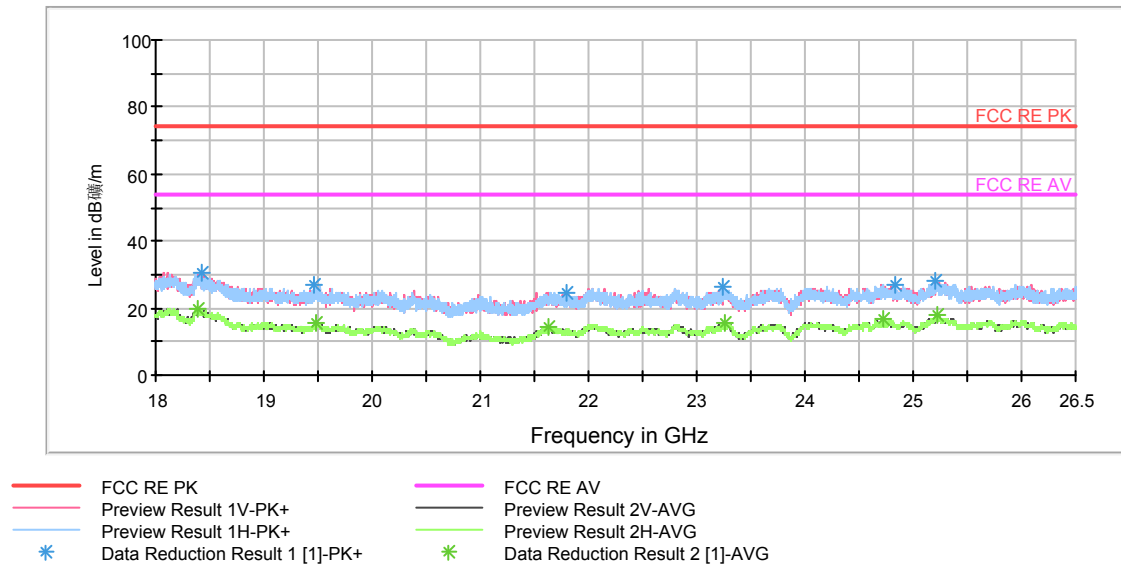

Note: This graph displays the maximum values of horizontal and vertical by software

Note: a font (Level in dBμV/m) in the test plot =(level in dBuV/m)

Note: The signal beyond the limit is carrier.

Radiates Emission from 18GHz to 26GHz

Frequency (MHz)	Peak (dBuV/m)	Polarization	Azimuth (deg)	Reading value (dBuV/m)	Correct Factor (dB)	Margin (dB)	Limit (dBuV/m)
18396.312500	28.7	V	0.0	33.6	-4.9	45.3	74
19480.062500	23.8	V	0.0	31.6	-7.8	50.2	74
21632.687500	23.0	H	0.0	32.1	-9.1	51.0	74
23251.937500	23.6	H	0.0	31.1	-7.5	50.4	74
24723.500000	24.0	V	0.0	30.2	-6.2	50.0	74
25231.375000	26.2	H	0.0	32.1	-5.9	47.8	74

Frequency (MHz)	Average (dBuV/m)	Polarization	Azimuth (deg)	Reading value (dBuV/m)	Correct Factor (dB)	Margin (dB)	Limit (dBuV/m)
18396.312500	20.0	V	0.0	24.9	-4.9	34.0	54
19480.062500	15.8	V	0.0	23.6	-7.8	38.2	54
21632.687500	14.4	H	0.0	23.5	-9.1	39.6	54
23251.937500	15.5	H	0.0	23.0	-7.5	38.5	54
24723.500000	16.6	V	0.0	22.8	-6.2	37.4	54
25231.375000	18.1	H	0.0	24.0	-5.9	35.9	54

2.10. Conducted Emission

Ambient condition

Temperature	Relative humidity	Pressure
23°C ~25°C	45%~50%	101.5kPa

Methods of Measurement

The EUT is placed on a non-metallic table of 80cm height above the horizontal metal reference ground plane. During the test, the EUT was operating in its typical mode. The test method is according to ANSI C63.10-2013. Connect the AC power line of the EUT to the L.I.S.N. Use EMI receiver to detect the average and Quasi-peak value. RBW is set to 9 kHz, VBW is set to 30kHz. The measurement result should include both L line and N line.

The test is in transmitting mode.

Test Setup

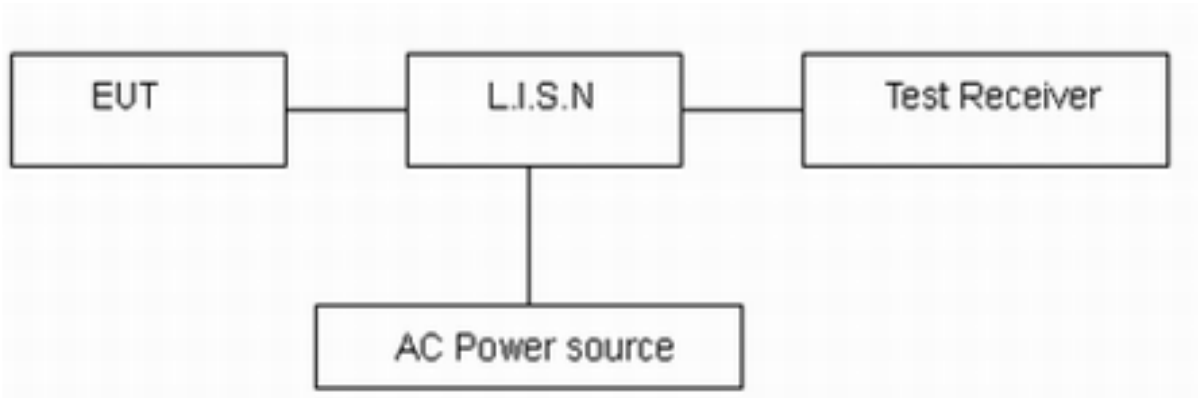

Note: AC Power source is used to change the voltage from 110V/60Hz.

Limits

TA Technology (Shanghai) Co., Ltd.
Test Report

Report No.: RXA1507-0128RF03R3

Page 44 of 54

Frequency (MHz)	Conducted Limits(dB μ V)	
	Quasi-peak	Average
0.15 - 0.5	66 to 56 *	56 to 46 *
0.5 - 5	56	46
5 - 30	60	50

*: Decreases with the logarithm of the frequency.

Measurement Uncertainty

The assessed measurement uncertainty to ensure 95% confidence level for the normal distribution is with the coverage factor $k = 1.96$, $U = 2.69$ dB.

TA Technology (Shanghai) Co., Ltd. Test Report

Test Results:

CH0

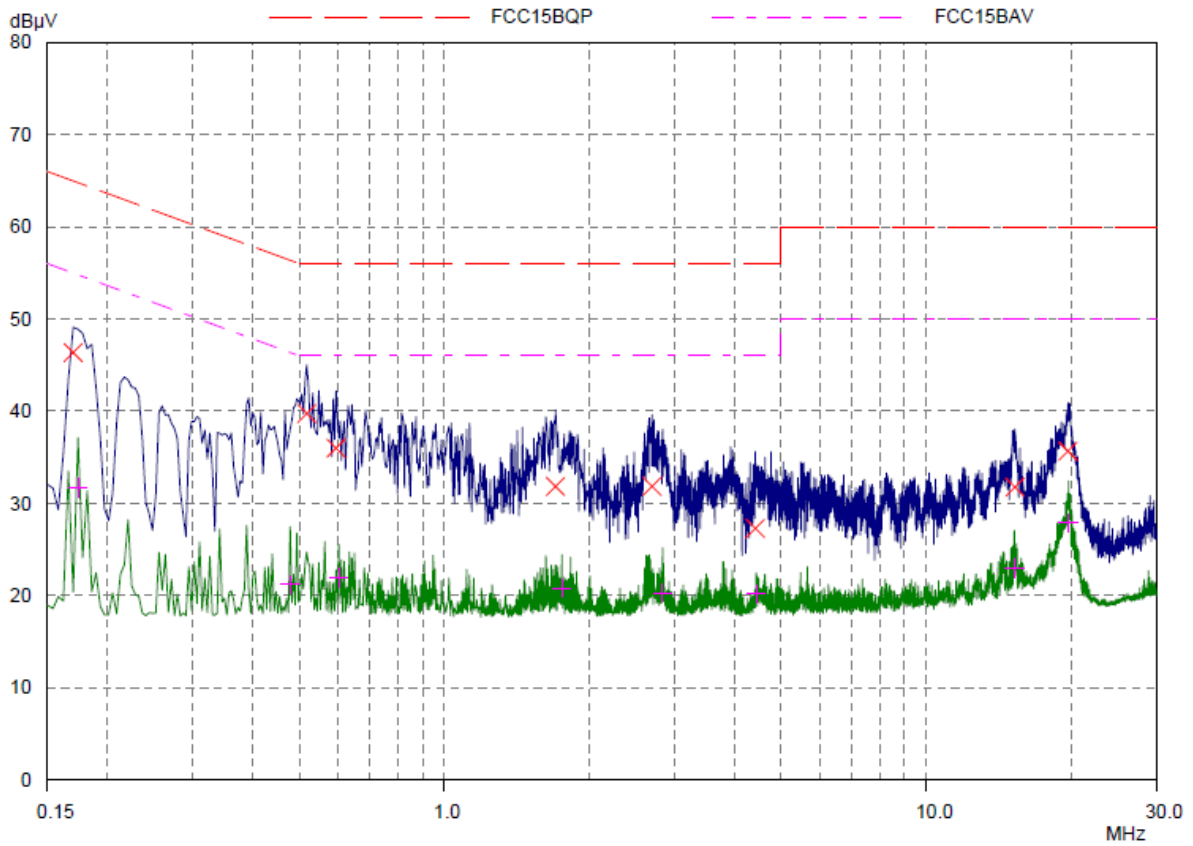

Final Measurement Results

Frequency MHz	QP Level dBµV	QP Limit dBµV	QP Delta dB	Phase	PE
0.16953	46.36	64.98	18.62	L1	gnd
0.51718	39.74	56.00	16.26	L1	gnd
0.59531	36.00	56.00	20.00	L1	gnd
1.70078	31.84	56.00	24.16	L1	gnd
2.69687	31.86	56.00	24.14	L1	gnd
4.41562	27.28	56.00	28.72	L1	gnd
15.26718	31.75	60.00	28.25	L1	gnd
19.67734	35.66	60.00	24.34	L1	gnd

Frequency MHz	AV Level dBµV	AV Limit dBµV	AV Delta dB	Phase	PE
0.17343	31.67	54.79	23.12	L1	gnd
0.47812	21.22	46.37	25.15	L1	gnd
0.60312	21.95	46.00	24.05	L1	gnd
1.75156	20.81	46.00	25.19	L1	gnd
2.83359	20.30	46.00	25.70	L1	gnd
4.43515	20.17	46.00	25.83	L1	gnd
15.22812	22.98	50.00	27.02	L1	gnd
19.73593	27.87	50.00	22.13	L1	gnd

L Line

TA Technology (Shanghai) Co., Ltd. Test Report

Report No.: RXA1507-0128RF03R3

Page 46 of 54

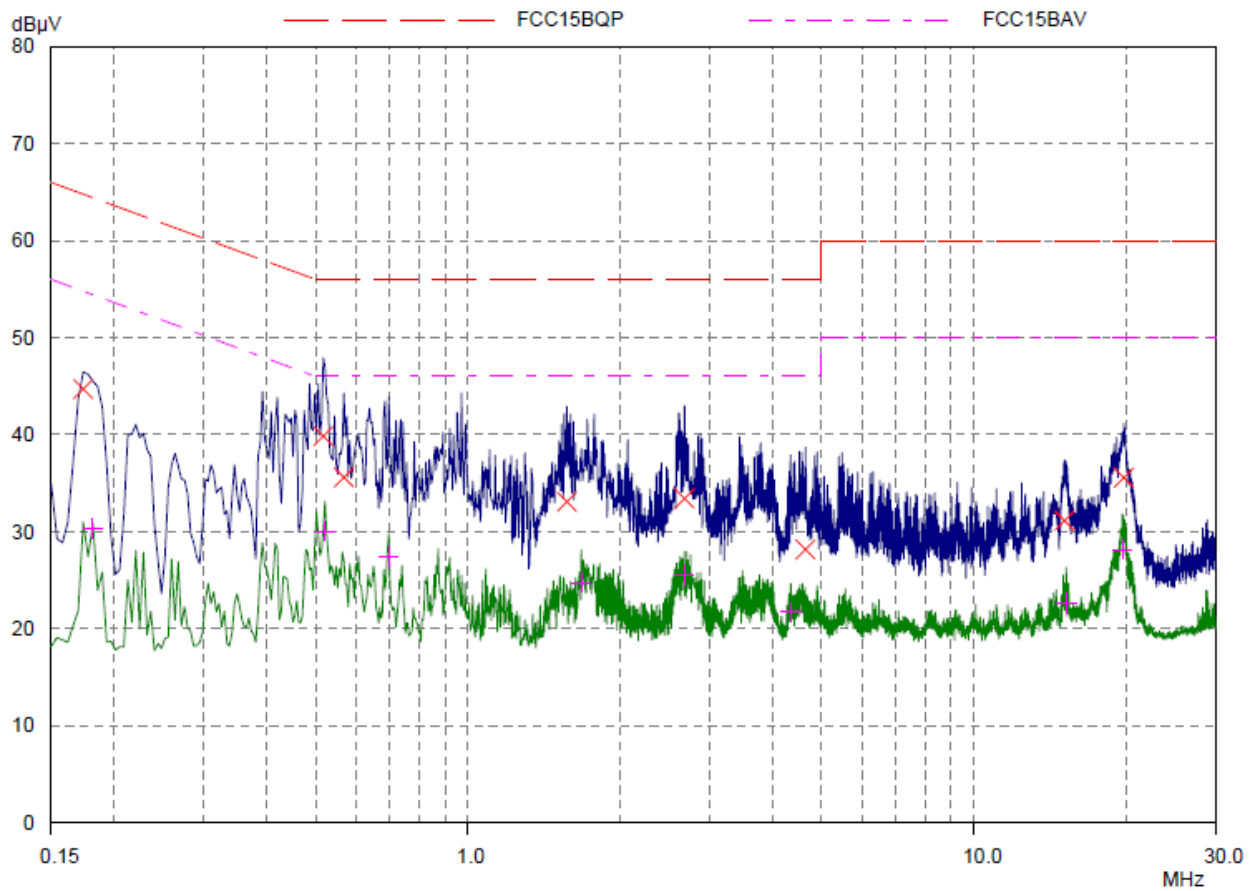

Final Measurement Results

Frequency MHz	QP Level dBµV	QP Limit dBµV	QP Delta dB	Phase -	PE -
0.17343	44.70	64.79	20.09	N	gnd
0.51718	39.86	56.00	16.14	N	gnd
0.56796	35.60	56.00	20.40	N	gnd
1.56796	33.08	56.00	22.92	N	gnd
2.67734	33.42	56.00	22.58	N	gnd
4.64609	28.18	56.00	27.82	N	gnd
15.09531	31.12	60.00	28.88	N	gnd
19.76718	35.57	60.00	24.43	N	gnd

Frequency MHz	AV Level dBµV	AV Limit dBµV	AV Delta dB	Phase -	PE -
0.18125	30.31	54.43	24.12	N	gnd
0.52109	30.06	46.00	15.94	N	gnd
0.69687	27.47	46.00	18.53	N	gnd
1.67343	24.76	46.00	21.24	N	gnd
2.67343	25.58	46.00	20.42	N	gnd
4.3414	21.73	46.00	24.27	N	gnd
15.2125	22.63	50.00	27.37	N	gnd
19.64609	28.14	50.00	21.86	N	gnd

N Line

TA Technology (Shanghai) Co., Ltd. Test Report

Report No.: RXA1507-0128RF03R3

Page 47 of 54

CH19

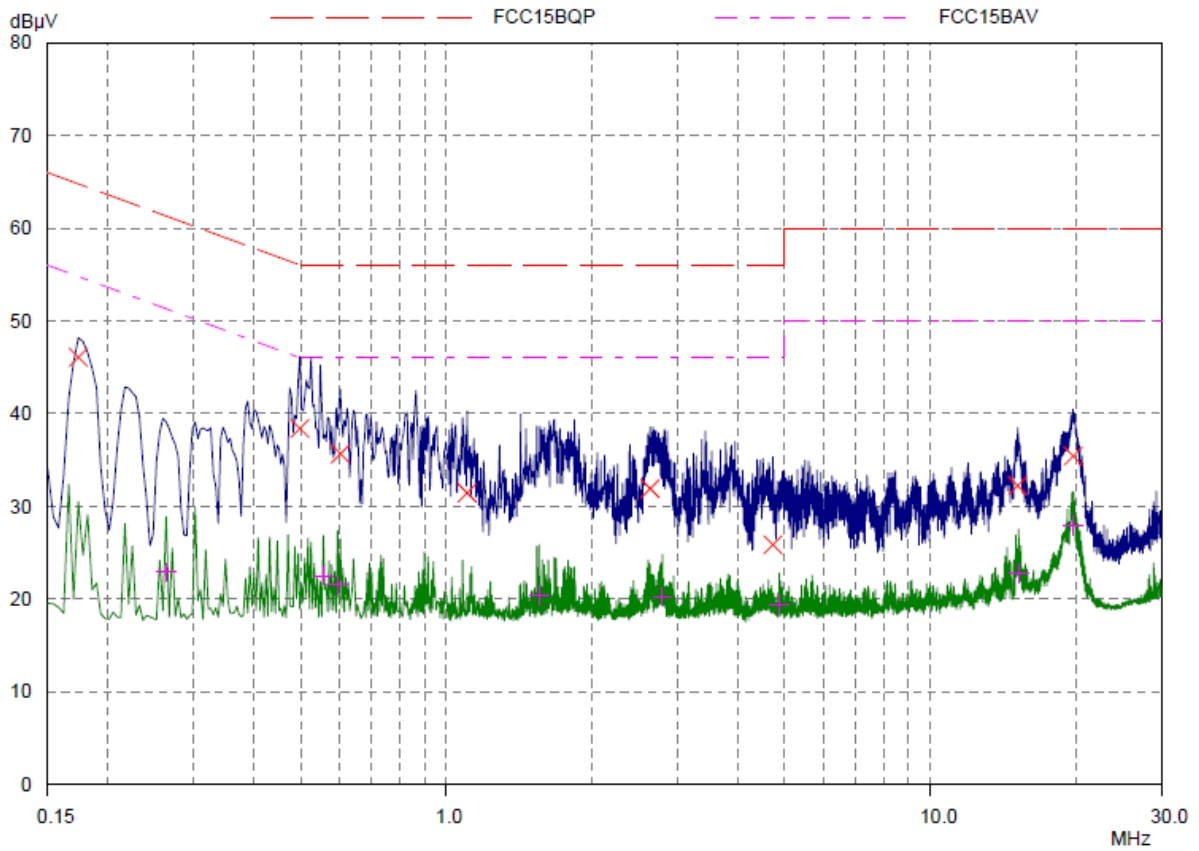

Final Measurement Results

Frequency MHz	QP Level dBµV	QP Limit dBµV	QP Delta dB	Phase -	PE -
0.17343	46.08	64.79	18.71	L1	gnd
0.49765	38.40	56.04	17.64	L1	gnd
0.60312	35.66	56.00	20.34	L1	gnd
1.10312	31.46	56.00	24.54	L1	gnd
2.63437	31.92	56.00	24.08	L1	gnd
4.72421	25.88	56.00	30.12	L1	gnd
15.13437	32.24	60.00	27.76	L1	gnd
19.70468	35.42	60.00	24.58	L1	gnd

Frequency MHz	AV Level dBµV	AV Limit dBµV	AV Delta dB	Phase -	PE -
0.26328	22.91	51.33	28.42	L1	gnd
0.55625	22.52	46.00	23.48	L1	gnd
0.59531	21.57	46.00	24.43	L1	gnd
1.55234	20.43	46.00	25.57	L1	gnd
2.79453	20.30	46.00	25.70	L1	gnd
4.87265	19.42	46.00	26.58	L1	gnd
15.2164	22.78	50.00	27.22	L1	gnd
19.68906	27.92	50.00	22.08	L1	gnd

L Line

TA Technology (Shanghai) Co., Ltd. Test Report

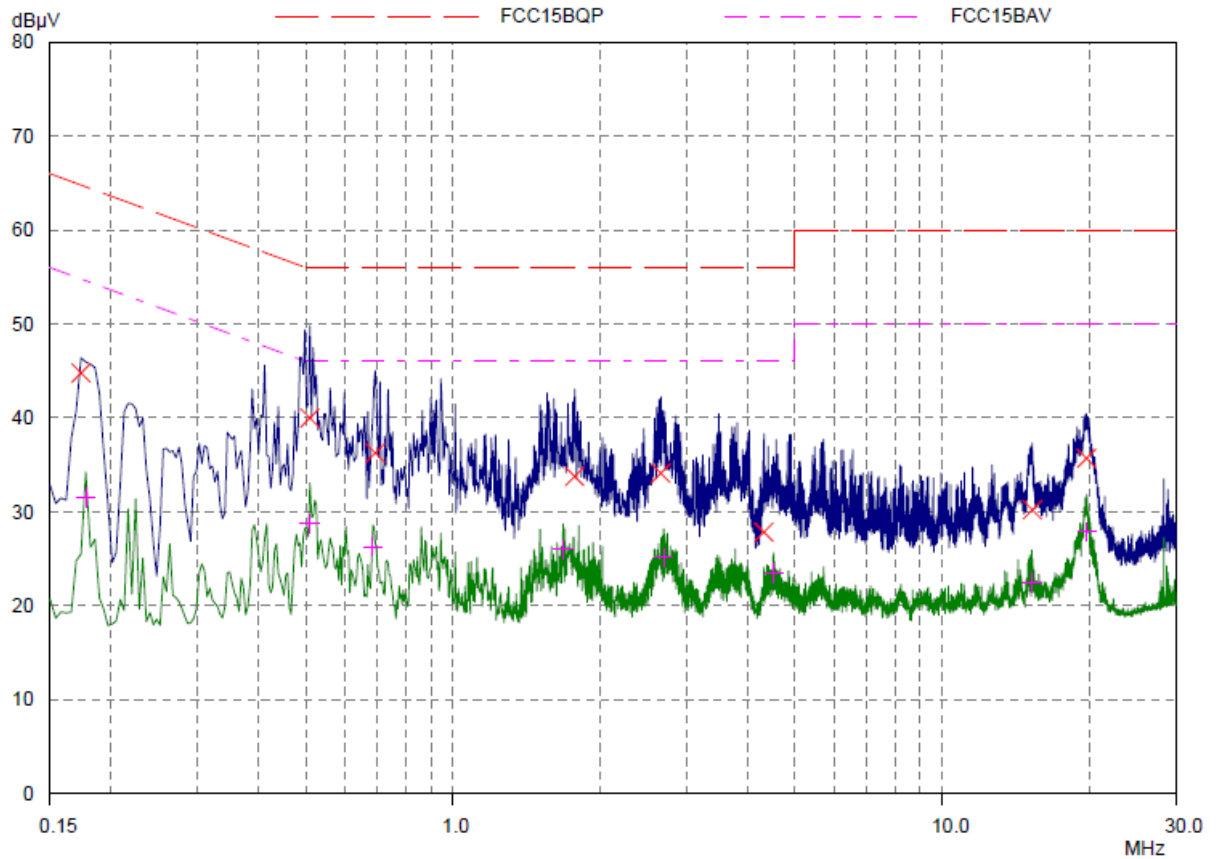

Final Measurement Results

Frequency MHz	QP Level dBµV	QP Limit dBµV	QP Delta dB	Phase -	PE -
0.17343	44.78	64.79	20.01	N	gnd
0.50937	40.00	56.00	16.00	N	gnd
0.69296	36.26	56.00	19.74	N	gnd
1.77109	33.76	56.00	22.24	N	gnd
2.65781	34.12	56.00	21.88	N	gnd
4.31796	27.84	56.00	28.16	N	gnd
15.26718	30.21	60.00	29.79	N	gnd
19.7125	35.70	60.00	24.30	N	gnd

Frequency MHz	AV Level dBµV	AV Limit dBµV	AV Delta dB	Phase -	PE -
0.17734	31.53	54.61	23.08	N	gnd
0.50937	28.74	46.00	17.26	N	gnd
0.68515	26.26	46.00	19.74	N	gnd
1.67734	25.99	46.00	20.01	N	gnd
2.69296	25.14	46.00	20.86	N	gnd
4.525	23.47	46.00	22.53	N	gnd
15.24765	22.42	50.00	27.58	N	gnd
19.75156	27.87	50.00	22.13	N	gnd

TA Technology (Shanghai) Co., Ltd. Test Report

CH39

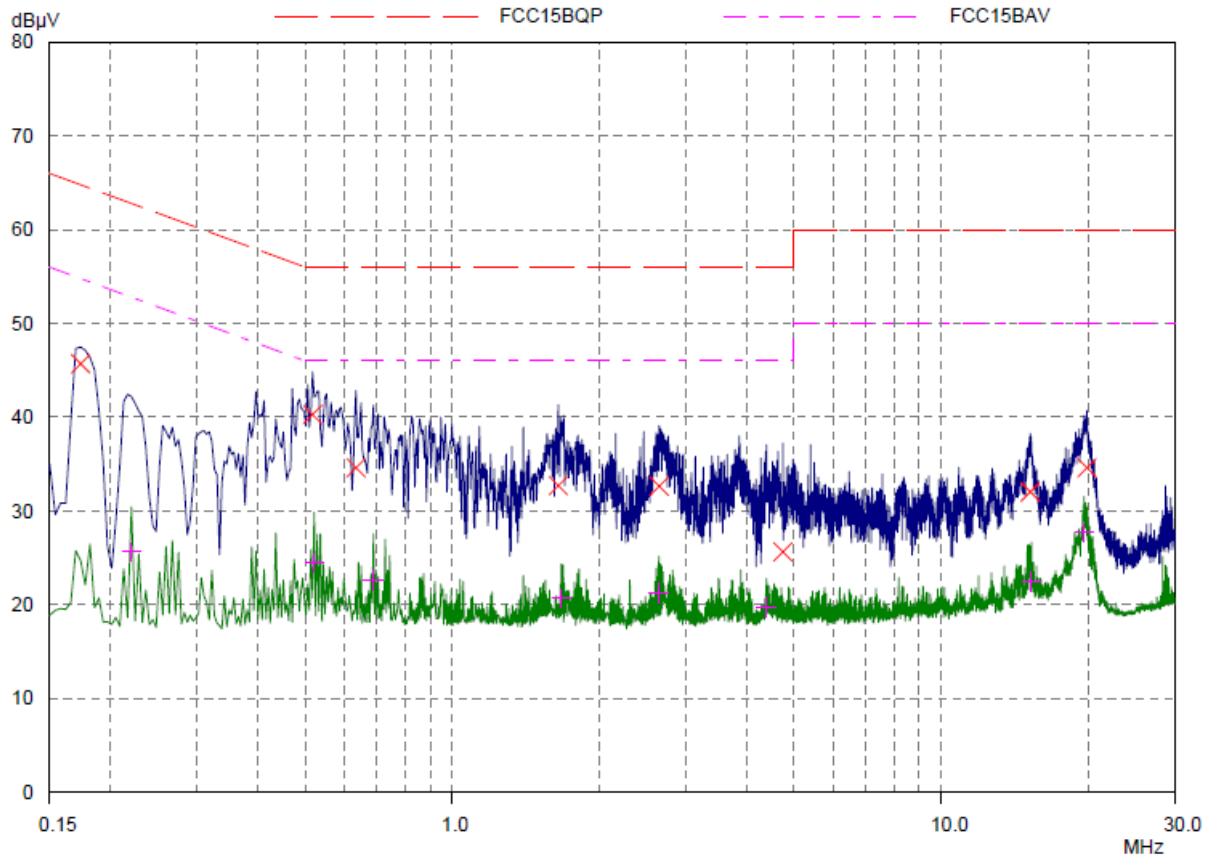

Final Measurement Results

Frequency MHz	QP Level dBµV	QP Limit dBµV	QP Delta dB	Phase -	PE -
0.17343	45.70	64.79	19.09	L1	gnd
0.51718	40.28	56.00	15.72	L1	gnd
0.63437	34.60	56.00	21.40	L1	gnd
1.64609	32.72	56.00	23.28	L1	gnd
2.64609	32.66	56.00	23.34	L1	gnd
4.74375	25.66	56.00	30.34	L1	gnd
15.19687	32.04	60.00	27.96	L1	gnd
19.85703	34.60	60.00	25.40	L1	gnd

Frequency MHz	AV Level dBµV	AV Limit dBµV	AV Delta dB	Phase -	PE -
0.22031	25.65	52.81	27.16	L1	gnd
0.52109	24.45	46.00	21.55	L1	gnd
0.68906	22.62	46.00	23.38	L1	gnd
1.66953	20.68	46.00	25.32	L1	gnd
2.64218	21.28	46.00	24.72	L1	gnd
4.38437	19.77	46.00	26.23	L1	gnd
15.28281	22.48	50.00	27.52	L1	gnd
19.58359	27.68	50.00	22.32	L1	gnd

L Line

TA Technology (Shanghai) Co., Ltd. Test Report

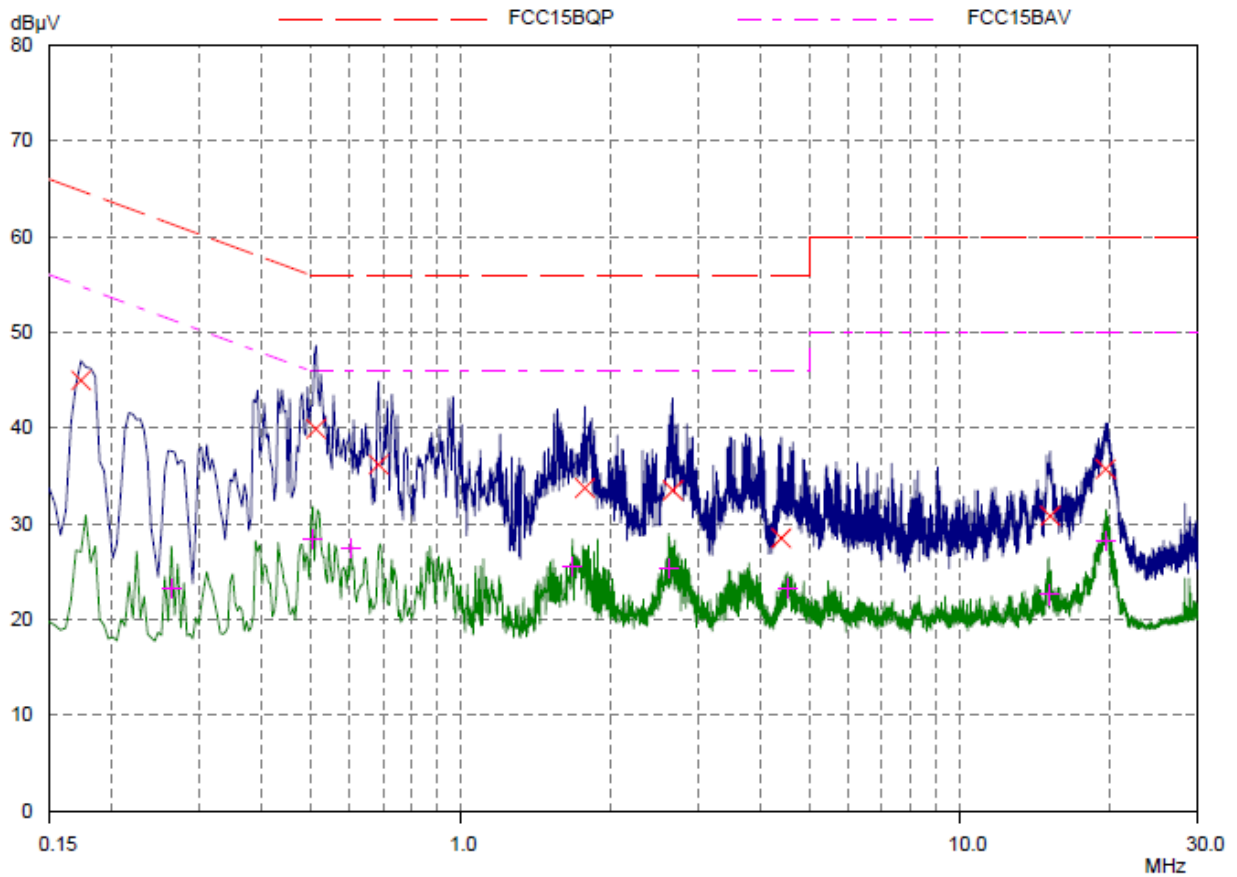

Final Measurement Results

Frequency MHz	QP Level dBµV	QP Limit dBµV	QP Delta dB	Phase -	PE -
0.17343	44.98	64.79	19.81	N	gnd
0.51327	39.90	56.00	16.10	N	gnd
0.68515	36.18	56.00	19.82	N	gnd
1.775	33.72	56.00	22.28	N	gnd
2.66562	33.48	56.00	22.52	N	gnd
4.39609	28.48	56.00	27.52	N	gnd
15.22812	30.81	60.00	29.19	N	gnd
19.66562	35.70	60.00	24.30	N	gnd

Frequency MHz	AV Level dBµV	AV Limit dBµV	AV Delta dB	Phase -	PE -
0.26328	23.29	51.33	28.04	N	gnd
0.50546	28.44	46.00	17.56	N	gnd
0.60312	27.36	46.00	18.64	N	gnd
1.67734	25.58	46.00	20.42	N	gnd
2.61484	25.29	46.00	20.71	N	gnd
4.52109	23.24	46.00	22.76	N	gnd
15.10703	22.57	50.00	27.43	N	gnd
19.68515	28.14	50.00	21.86	N	gnd

N Line

TA Technology (Shanghai) Co., Ltd.
Test Report

Report No.: RXA1507-0128RF03R3

Page 51 of 54

3. Main Test Instruments

No.	Name	Type	Manufacturer	Serial Number	Calibration Date	Expiration Time	Valid Period
01	Spectrum Analyzer	E4445A	Agilent	MY4618114 6	2015-05-22	2016-05-21	1 year
02	LISN	ENV216	R&S	101171	2013-12-18	2016-12-17	3 years
03	EMI Test Receiver	ESCS30	R&S	100138	2014-12-17	2015-12-16	1 year
04	EMI Test Receiver	ESCI	R&S	100948	2015-05-22	2016-05-21	1 year
05	Spectrum Analyzer	FSV30	R&S	100815	2014-12-18	2015-12-17	1 year
06	Loop Antenna	FMZB1516	SCHWARZBECK	237	2014-02-19	2017-02-18	3 years
07	TRILOG Broadband Antenna	VULB 9163	Schwarzbeck	9163-201	2014-12-06	2017-12-05	3 years
08	Double Ridged Waveguide Horn Antenna	HF907	R&S	100126	2014-12-06	2017-12-05	3 years
09	Standard Gain Horn	3160-09	ETS-Lindgren	00102644	2015-01-30	2018-01-29	3 years
10	Power Splitter	SHX-GF2-2-13	Hua Xiang	10120101	NA	NA	NA
11	RF Cable	SMA 15cm	Agilent	0001	2015-08-17	2015-10-16	Two months
12	Bore Sight Antenna mast	2171B	ETS	00058752	NA	NA	NA

*****END OF REPORT *****

ANNEX A: EUT Appearance and Test Setup

A.1 EUT Appearance



Picture 1 EUT and Auxiliary

A.2 Test Setup

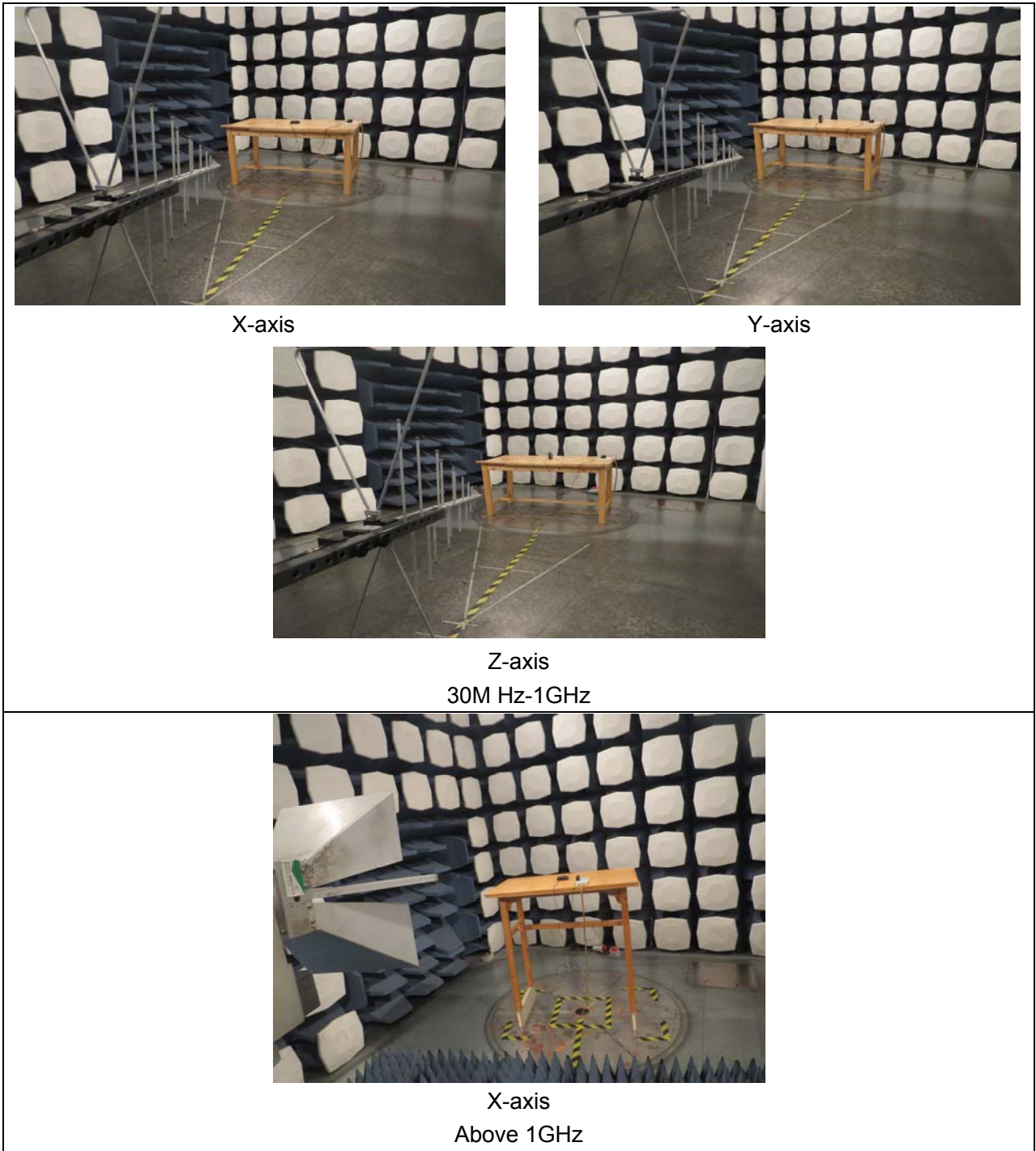

X-axis

Y-axis

Z-axis

30M Hz-1GHz

X-axis

Above 1GHz

Picture 2 Radiated Emission Test Setup

TA Technology (Shanghai) Co., Ltd.
Test Report

Report No.: RXA1507-0128RF03R3

Page 54 of 54



Picture 3 Conducted Emission Test Setup