

RF Test Report:

Roke "Smartlink"

FCC ID: 2AF27-9317219

IC: 20630-9317219

SC_TR_168_C

Prepared for:

Chemring Technology Solutions
Old Salisbury Lane
Romsey
SO51 0ZN
UK

Contents

1	Revision History	4
2	Purpose.....	4
3	Reference Documents	4
4	Test Information	5
4.1	Client and manufacturer.....	5
4.2	Test Locations.....	5
4.3	Test sample.....	5
5	Product Description.....	6
6	Test Configuration	7
6.1	Test sample and Operating mode	7
6.2	Support equipment.....	7
6.3	Equipment set-up.....	8
6.4	Supported Antennas	8
7	Summary of Tests performed	9
8	Transmit Power	10
8.1	Test method	10
8.2	Test results	10
9	Spectral Power Density	12
9.1	Test method	12
9.2	Test results	12
10	Occupied Bandwidth	13
11	Conducted Spurious Emissions inc. Band Edge	14
11.1	Requirement and test method.....	14
11.2	Band edge results	15
11.3	Conducted spurious emissions	16
12	Radiated Spurious Emissions.....	19
12.1	Requirement and test method.....	19
12.2	Results	19
12.3	Final pre-scans	20
12.4	Initial pre-scans	21
13	Test equipment and measurement uncertainty.....	25



Tables

Table 1: Equipment under test	7
Table 2: Support Equipment	7
Table 3: EUT Antenna configurations.....	8
Table 4: Summary of tests performed	9
Table 5: Transmit power	10
Table 6: Transmit power spectral density	12
Table 7: Occupied Bandwidth test results	13
Table 8: Conducted spurious emissions (Band edge).....	15
Table 9: Conducted spurious emissions	16
Table 10: Test Equipment.....	25
Table 11: Measurement uncertainty	25

Figures

Figure 1: Configuration for test	8
Figure 2: Peak to Average (PAR) plots for two supported modulations.....	10
Figure 3: Transmit Power and PAR plots	11
Figure 4: Transmit Power Spectral Density plots.....	12
Figure 5: Occupied Bandwidth plots – worst case	13
Figure 6: Conducted Spurious Emissions (band edge).....	16
Figure 7: CSE plots: Ch 1587 QPSK	17
Figure 8: CSE plots: Ch 1587: 16QAM.....	18
Figure 9: RSE pre-scans : 30-1000 MHz	21
Figure 10: RSE pre-scans : 1 – 4 GHz	22
Figure 11: RSE pre-scans : 4 - 18 GHz.....	23
Figure 12: RSE pre-scans : 18 - 23 GHz	24

1 Revision History

Revision	Originator	Date	Comment	Signature
A	C Blackham Director, Sulis Consultants Ltd	06 October 2015	1 st release	
B	C Blackham Director, Sulis Consultants Ltd	04 November 2015	Updated sections 5,7 and 13	
B	C Blackham Director, Sulis Consultants Ltd	09 November 2015	Additional clarification to section 13	

2 Purpose

This document details the Chemring Technology Solutions "Smartlink" Outdoor Cellular Basestation, model number X72-1-9317-219, designed to transmit in the 2110-2155 MHz band.

3 Reference Documents

- | | | |
|-----|-------------------------------------|--|
| [1] | 47CFR2 | Title 47 Code of Federal Regulations Part 2: frequency allocations and radio treaty matters; general rules and regulations |
| [2] | 47 CRF27 | Title 47 Code of Federal Regulations Part 27: Miscellaneous Communications Services |
| [3] | RSS-139 Issue 3 | Industry Canada Spectrum Management and Telecommunications Radio Standards Specification Advanced Wireless Services (AWS) Equipment Operating in the Bands 1710-1780 MHz and 2110-2180 MHz |
| [4] | RSS-Gen Issue 4 (November 13, 2014) | Industry Canada Spectrum Management and Telecommunications Radio Standards Specification General Requirements for Compliance of Radio Apparatus |
| [5] | SRSP-513 Issue 3 | Technical Requirements for Advanced Wireless Services (AWS) in the Bands 1710-1780 MHz and 2110-2180 MHz |
| [6] | TIA-603-D | Land Mobile FM or PM – Communications Equipment – Measurement and Performance Standards |
| [7] | KDB971168 DO1 v02r02 | Federal Communications Commission Office of Engineering and Technology Laboratory Division; Measurement guidance for certification of licensed digital transmitters. |

4 Test Information

4.1 Client and manufacturer

Chemring Technology Solutions
Old Salisbury Lane
Romsey
SO51 0ZN
UK

4.2 Test Locations

Antenna port tests

Testing was performed by Charlie Blackham of Sulis Consultants Ltd on 14th September 2015 at Chemring's offices detailed in section 4.1

Radiated Spurious Emissions (section 12)

Initial scans to identify worst case modes were performed by Charlie Blackham of Sulis Consultants Ltd on 14th September 2015 at Chemring's offices detailed in section 4.1

Further scans and final measurements were made by Richard Pennell of Hursley EMC Services Ltd under job number 15R407 at:

Hursley EMC services Ltd
Trafalgar House
Trafalgar Close
Chandlers Ford
SO53 4BW
UK

- FCC accredited test facility, UK designation number UK0006
- Industry Canada test facility 7104A-1.

4.3 Test sample

The results herein only refer to sample detailed in section 6

5 Product Description

The basestation supports operation with 5 MHz channel bandwidth in WCDMA mode at the following modulation rates:

- QPSK
- 16 QAM

The unit is fitted with one RF transceiver RF port, "3G TX/RX" and one receive only port "3G RX".

The rated power of the unit is 2W and the test sample had been previously calibrated to give maximum permitted transmit power of 32.8 dBm using 3GPP test model 1.

Measurements were performed on the following channels within the band of operation:

Channel 1538 : 2112.6 MHz (bottom)

Channel 1587 : 2122.4 MHz (nominal channel used for test and calibration)

Channel 1737 : 2152.2 MHz (top)

The 3GPP test waveform has a 100% duty cycle so no gating or allowance for duty cycle is required when taking measurements.

The Frequency stability has been measured in separate report and been shown to be better than ± 0.03 PPM

6 Test Configuration

6.1 Test sample and Operating mode

The equipment under test (EUT) was:

Manufacturer	Name	Model Number	Serial Number
Chemring Technology Solutions	Smartlink	X72-1-9317-219	124485

Table 1: Equipment under test

Modifications during test: None

6.2 Support equipment

The support equipment was:

Description	Manufacturer	Name	Serial Number
Laptop	HP	Folio 13	CND151K3TT
External power supply	Traco Power	TEX 120-124	None

Table 2: Support Equipment

6.3 Equipment set-up

Equipment was configured as per figure 2:

- Smartlink was configured PUTTY application that allowed the unit to be placed into a test mode and the required frequency and power to be set
- During conducted emissions, the insertion loss of the attenuator and Co-ax cable were calibrated before testing and their combined path-loss was programmed into the analyser as a Transducer Factor.

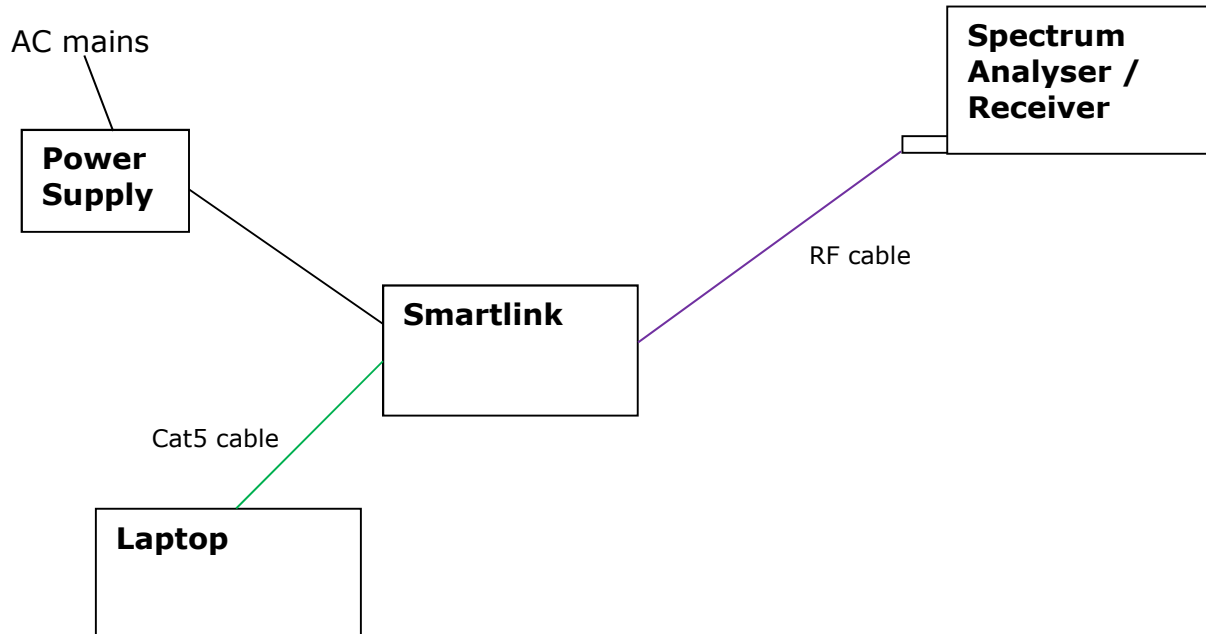

Figure 1: Configuration for test

6.4 Supported Antennas

The EUT supports operation with the following antennas:

Antenna type	Type	Gain
External	Omnidirectional	5 dBi
External	Omnidirectional	2 dBi

Table 3: EUT Antenna configurations

All calculations for EIRP are made using the worst case 5dBi antenna.

7 Summary of Tests performed

Tests were performed on several channels

UARFCN	Centre Frequency (MHz)	5 MHz channel band edges (MHz)
1538	2112.6	2110.1 - 2115.1
1587	2122.4	2119.9 - 2124.9
1737	2152.4	2149.9 - 2154.9

Test	47 CFR Part	FCC limit	IC	IC limit	Result / Section
Transmit Power	27.50(d)(2) / 2.1046	1640 W /MHz EIRP	RSS-139 section 6.4 SRSP-513 section 5.1.1	1640 W /MHz EIRP	Pass 8
Spectral Power Density	27.50(d)(2) / 2.1046	1640 W EIRP/MHz	RSS-139 section 6.4 SRSP-513 section 5.1.1	1640 W EIRP/MHz	Pass 9
Occupied Bandwidth	2.1049	None	RSS-Gen section 6.6	5 MHz ¹	Pass 10
Conducted Spurious Emissions (out of band)	27.53(h) / 2.1051	-13 dBm	RSS-139 section 6.5	-13 dBm	Pass 11
Radiated Spurious Emissions	27.53(h) / 2.1053	-13 dBm	RSS-139 section 6.5	-13 dBm	Pass 12
Frequency Stability	2.1055	None	RSS-139 section 6.3	Stay within operating frequency block	Pass Report SC_TR_171_B

Table 4: Summary of tests performed

¹ 5 MHz is the allocated channel

8 Transmit Power

8.1 Test method

The equipment was configured as per figure 1 and the measurements were made in accordance with KDB 971168 D01 using an RMS detector and the Peak to Average ratio was measured using the CCDF function of the analyser.

8.2 Test results

The table below shows the results for plots in figures 2 and 3.

UARFCN	TX power (dBm)	TX power EIRP (dBm)	TX power EIRP (W)	Limit EIRP (W)	0.1% PAR	Result
QPSK						
1537	31.94	36.94	4.94	1640.0	6.66 (limit 13.0)	Pass
1587	32.79	37.79	6.01	1640.0		Pass
1737	31.26	36.26	4.23	1640.0		Pass
16 QAM						
1537	31.03	36.03	4.01	1640.0	8.41 (limit 13.0)	Pass
1587	31.76	36.76	4.74	1640.0		Pass
1737	30.19	35.19	3.30	1640.0		Pass

Table 5: Transmit power

Peak to Average (PAR) ratio is related to the modulation waveform, and not the frequency of operation, so results presented for channel 1587 cover all frequencies in this band of operation

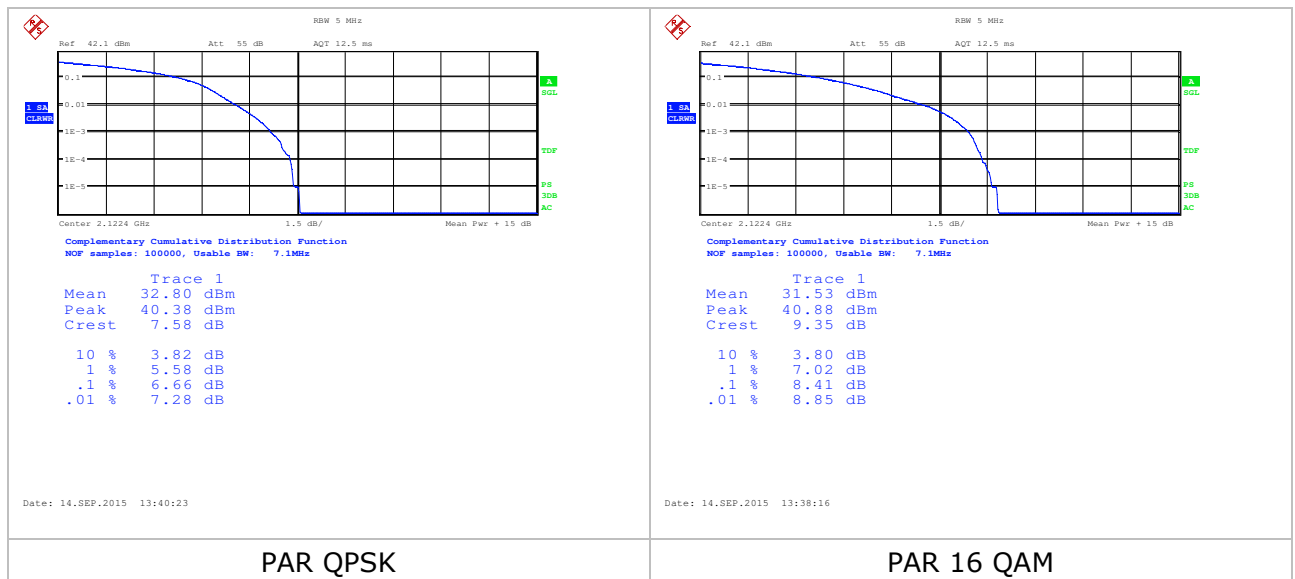

Figure 2: Peak to Average (PAR) plots for two supported modulations

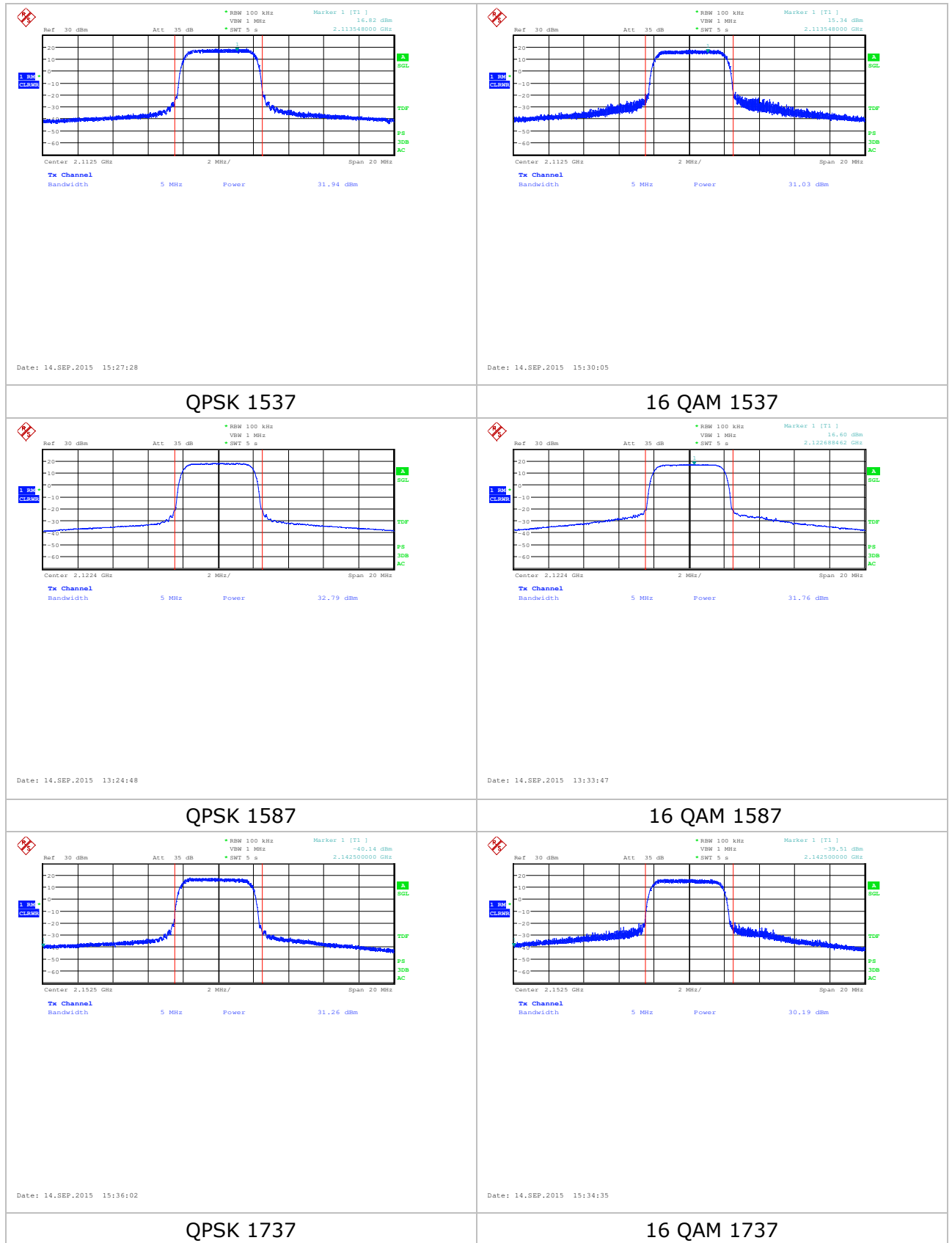

Figure 3: Transmit Power and PAR plots

9 Spectral Power Density

9.1 Test method

The test method is similar to that in section 8.1 except that a 1 MHz RBW and peak search was used.

9.2 Test results

The table below shows the worst case results along with plots in figure 4.

Modulation	TX power (dBm/MHz)	TX power EIRP (dBm/MHz)	TX power EIRP (W/MHz)	Limit EIRP (W/MHz)	Result
QPSK	27.84	32.84	1.92	1640.0	Pass
16 QAM	26.69	31.69	1.45	1640.0	Pass

Table 6: Transmit power spectral density

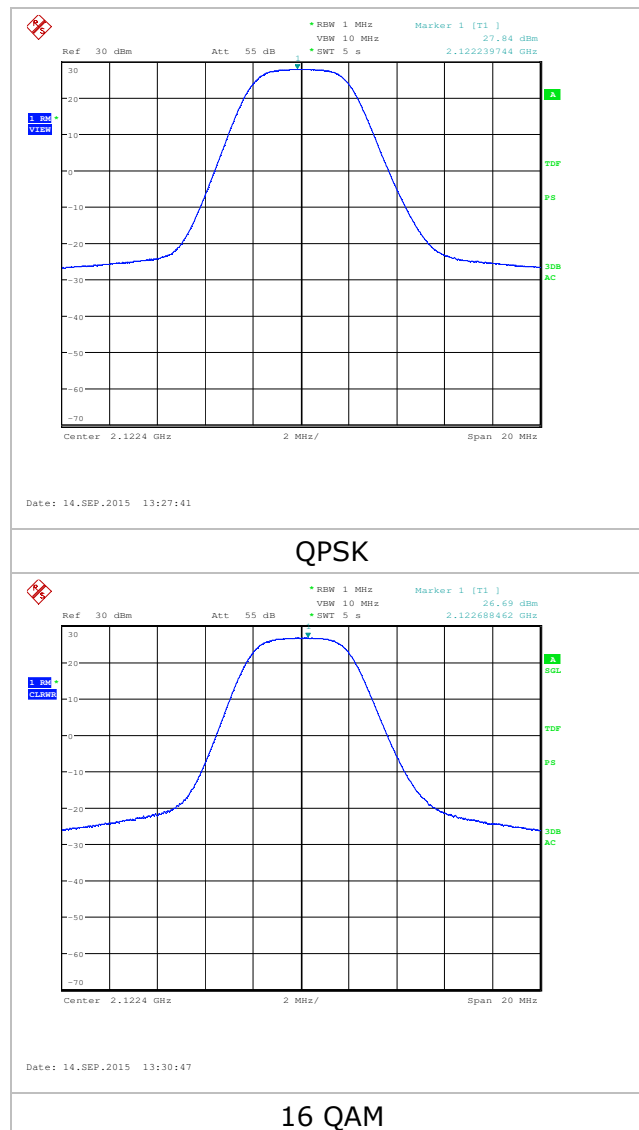

Figure 4: Transmit Power Spectral Density plots

10 Occupied Bandwidth

The occupied bandwidth was measured using the inbuilt function on the Signal Analyser set to measure the 99% emission bandwidth. Measurement was made using RMS detector.

Results are reported with reference to the 5 MHz channel that would be used for this product

The table below shows the results obtained with worst case plots shown in figure 5.

Modulation	UARFCN	Occupied Bandwidth (MHz)	Limit	Result
QPSK	1537	4.140	5.0	Pass
	1587	4.167	5.0	Pass
	1737	4.143	5.0	Pass
QAM	1537	4.143	5.0	Pass
	1587	4.167	5.0	Pass
	1737	4.142	5.0	Pass

Table 7: Occupied Bandwidth test results

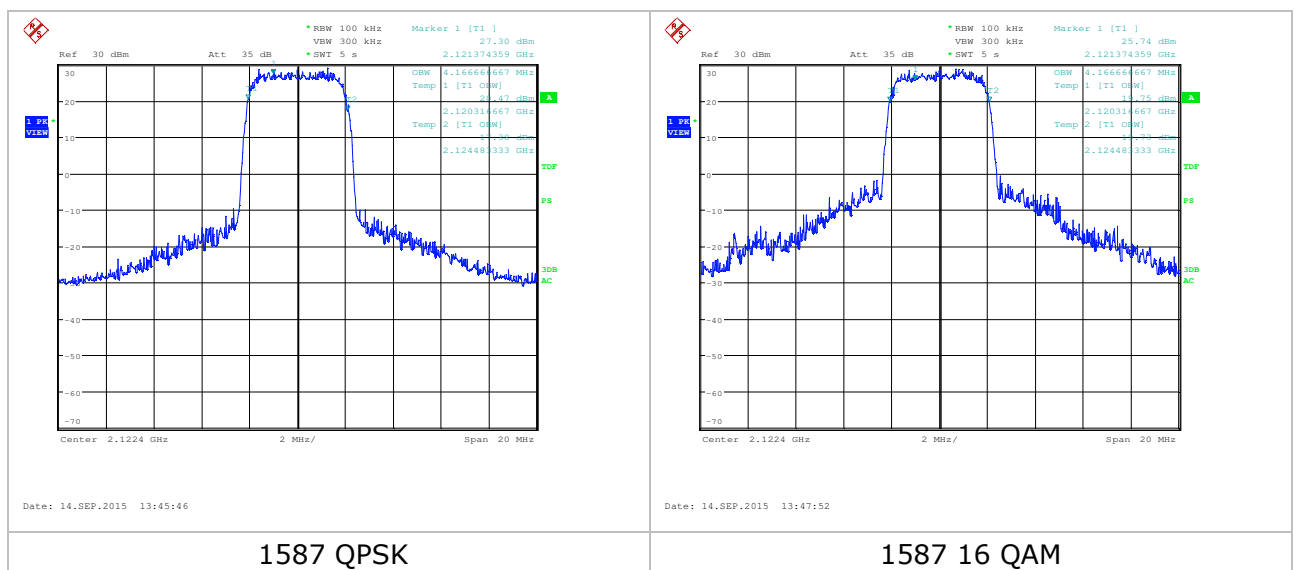

Figure 5: Occupied Bandwidth plots – worst case

11 Conducted Spurious Emissions inc. Band Edge

11.1 Requirement and test method

FCC

27.53(h) AWS emission limits—(1) General protection levels. Except as otherwise specified below, for operations in the 1695-1710 MHz, 1710-1755 MHz, 1755-1780 MHz, 1915-1920 MHz, 1995-2000 MHz, 2000-2020 MHz, 2110-2155 MHz, 2155-2180 MHz, and 2180-2200 MHz bands, the power of any emission outside a licensee's frequency block shall be attenuated below the transmitter power (P) in watts by at least $43 + 10 \log_{10}(P)$ dB.

(3) Measurement procedure.

(i) Compliance with this provision is based on the use of measurement instrumentation employing a resolution bandwidth of 1 megahertz or greater. However, in the 1 megahertz bands immediately outside and adjacent to the licensee's frequency block, a resolution bandwidth of at least one percent of the emission bandwidth of the fundamental emission of the transmitter may be employed. The emission bandwidth is defined as the width of the signal between two points, one below the carrier center frequency and one above the carrier center frequency, outside of which all emissions are attenuated at least 26 dB below the transmitter power.

(ii) When measuring the emission limits, the nominal carrier frequency shall be adjusted as close to the licensee's frequency block edges, both upper and lower, as the design permits.

(iii) The measurements of emission power can be expressed in peak or average values, provided they are expressed in the same parameters as the transmitter power.

Industry Canada

RSS 139 section 6.5 Transmitter Unwanted Emissions

(i) In the first 1.0 MHz bands immediately outside and adjacent to the equipment's operating frequency block, the emission power per any 1% of the emission bandwidth shall be attenuated below the transmitter output power P (in watts) by at least $43 + 10 \log_{10}(P)$, dB.

(ii) After the first 1.0 MHz outside the equipment's operating frequency block, the emission power in any 1 MHz bandwidth shall be attenuated below the transmitter output power P (in watts) by at least $43 + 10 \log_{10}(P)$, dB.

The licensed band of operation was considered to be a single 5 MHz channel for the 5 MHz operation of Smartlink. For operation on 2112.4 MHz, the band edge is therefore 2119.9 and 2124.9 MHz,

Emissions exceeded the limit close to the fundamental transmission frequency and these were investigated using RMS detector and adjacent channel power measurement capability of the spectrum analyser as shown on plots Screen 11.

11.2 Band edge results

Results for band edge show compliance with emissions limits for frequencies within a 3 MHz band below and above the 5 MHz block containing the transmit frequency.

Modulation	UARFCN	Centre Frequency (MHz)	Highest emission (dBm)	Limit EIRP (dBm)	Result
QPSK	1538	2112.6	-19.23	-13.0	Pass
	1587	2122.4	-18.25	-13.0	
	1737	2152.4	-20.60	-13.0	
16 QAM	1538	2112.6	-18.50	-13.0	Pass
	1587	2122.4	-14.55	-13.0	
	1737	2152.4	19.38	-13.0	

Table 8: Conducted spurious emissions (Band edge)

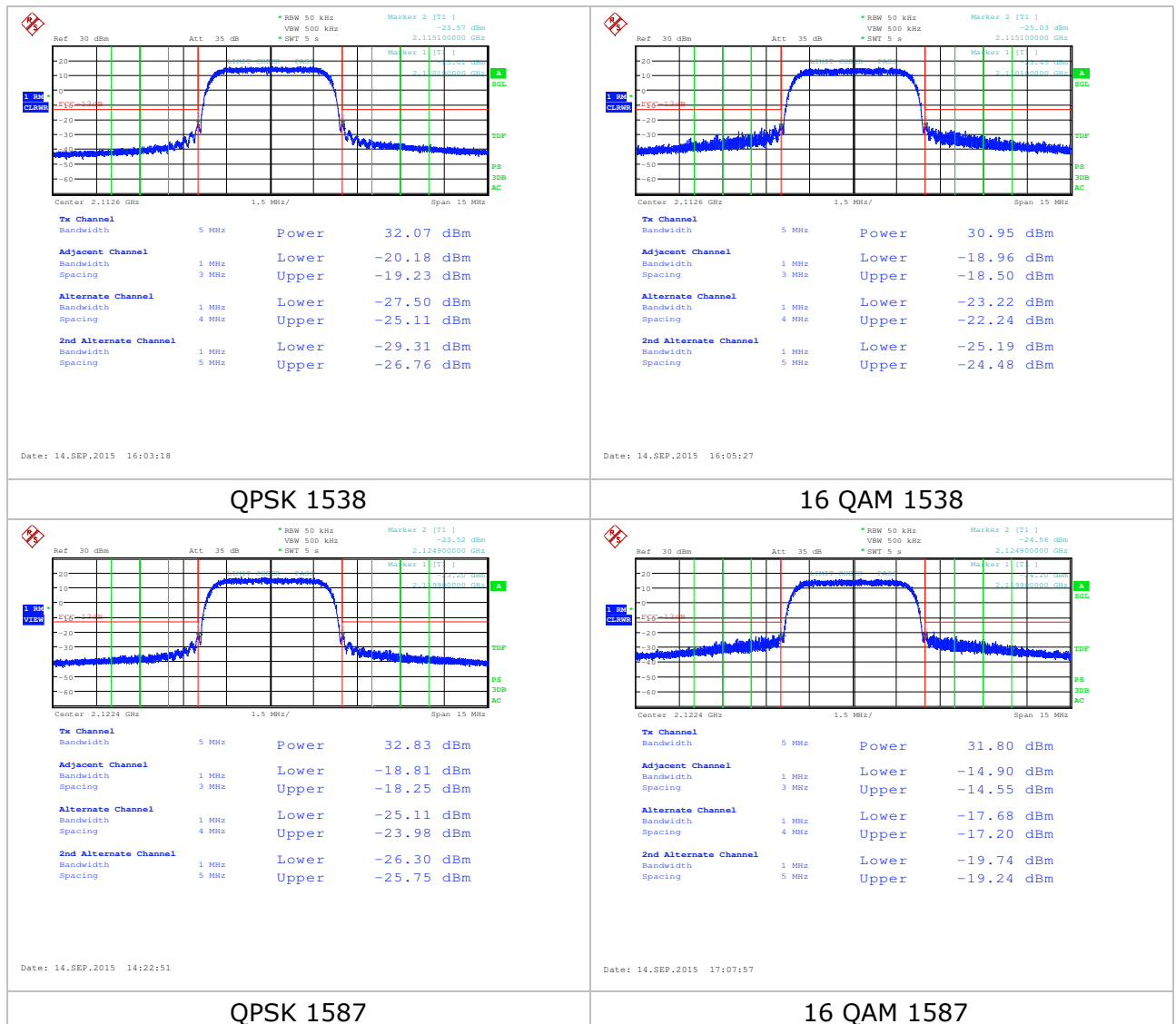

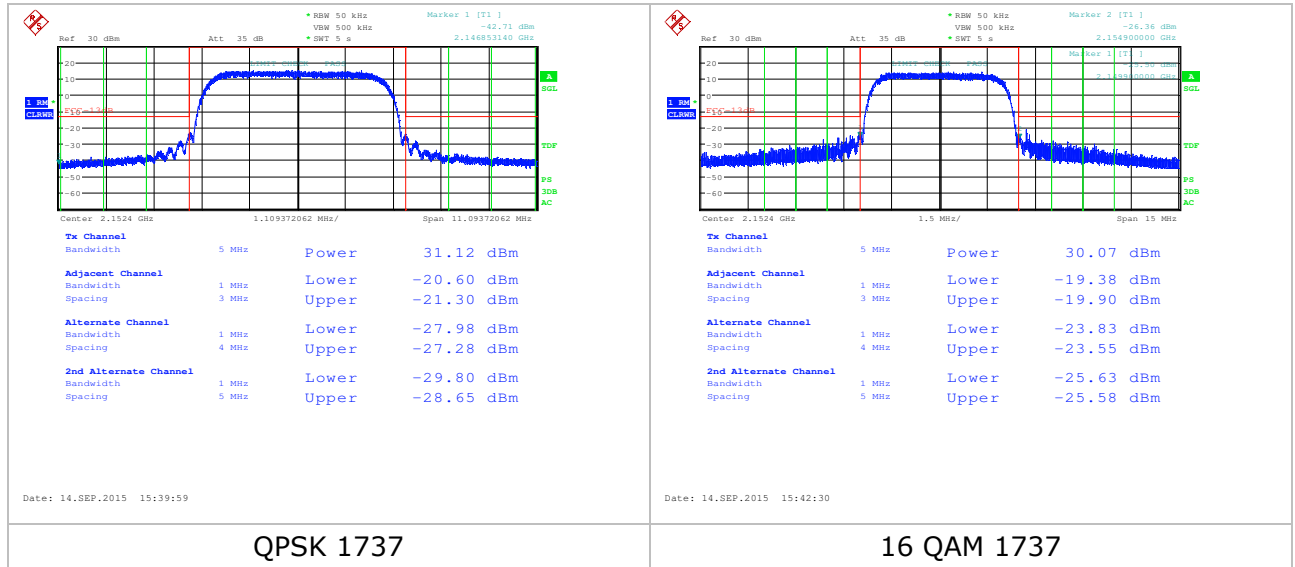

Figure 6: Conducted Spurious Emissions (band edge)

11.3 Conducted spurious emissions

Emissions were investigated outside of the channel bandwidth ± 3 MHz.

Tabulated results are presented for worst case results, which was channel 1587:

Frequency Range	Maximum emission QPSK (dBm)	Maximum emission 16 QAM (dBm)	Limit (dBm)	Result
10-1000 MHz	-59.89	-60.8	-13.0	Pass
1000-2115 MHz	-25.78	-24.98	-13.0	Pass
2115-2116.9 MHz And 2127.9 -2130 MHz See note 1	-21.52	-17.98	-13.0	Pass
2130-8000 MHz	-27.85	-23.24	-13.0	Pass
8 - 15 GHz	-39.75	-39.89	-13.0	Pass
15-22 GHz	-39.32	-39.75	-13.0	Pass

Table 9: Conducted spurious emissions

Note:

1. Measurements for emissions within 3 MHz of band edge are reported in section 11.2

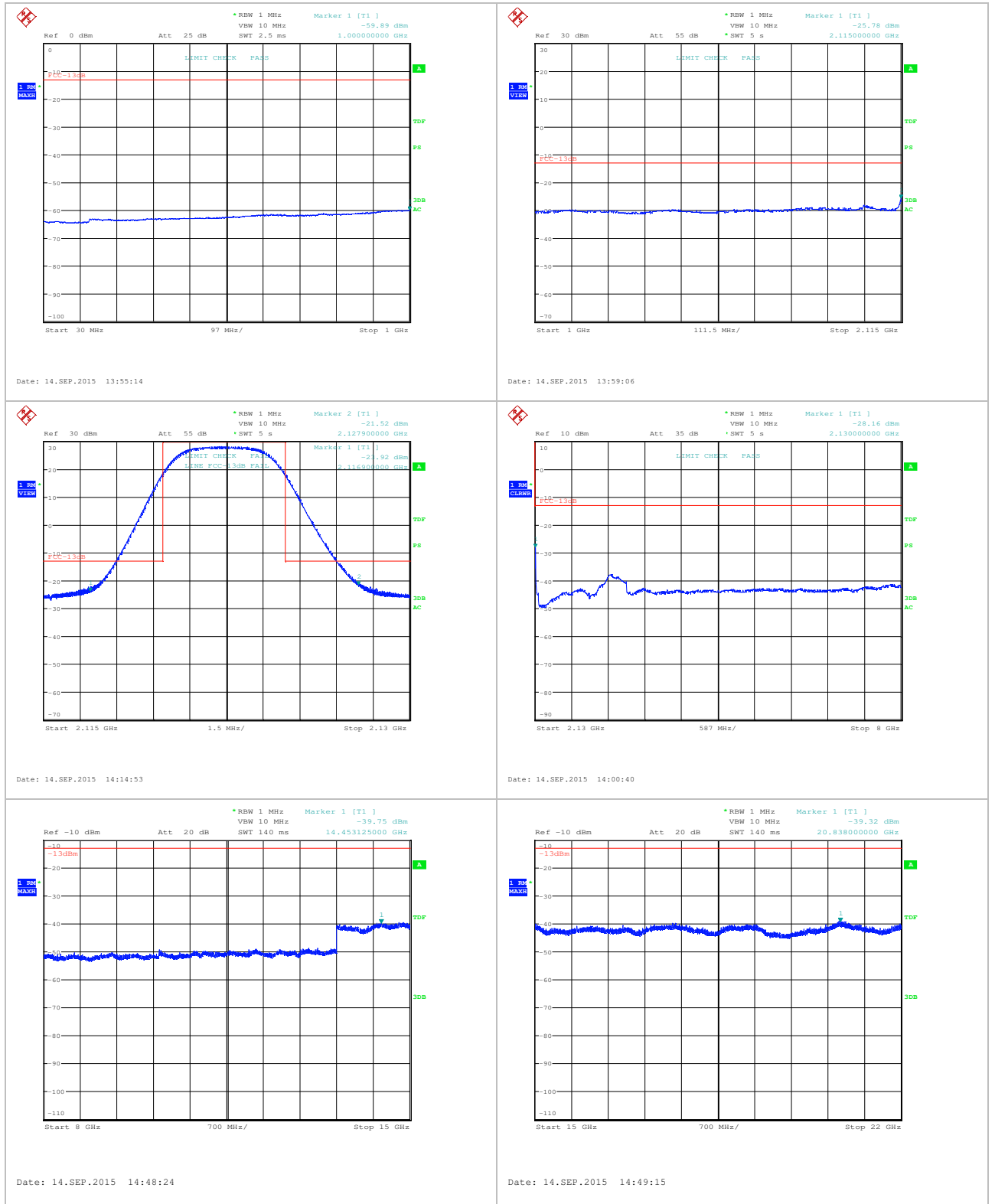

Figure 7: CSE plots: Ch 1587 QPSK

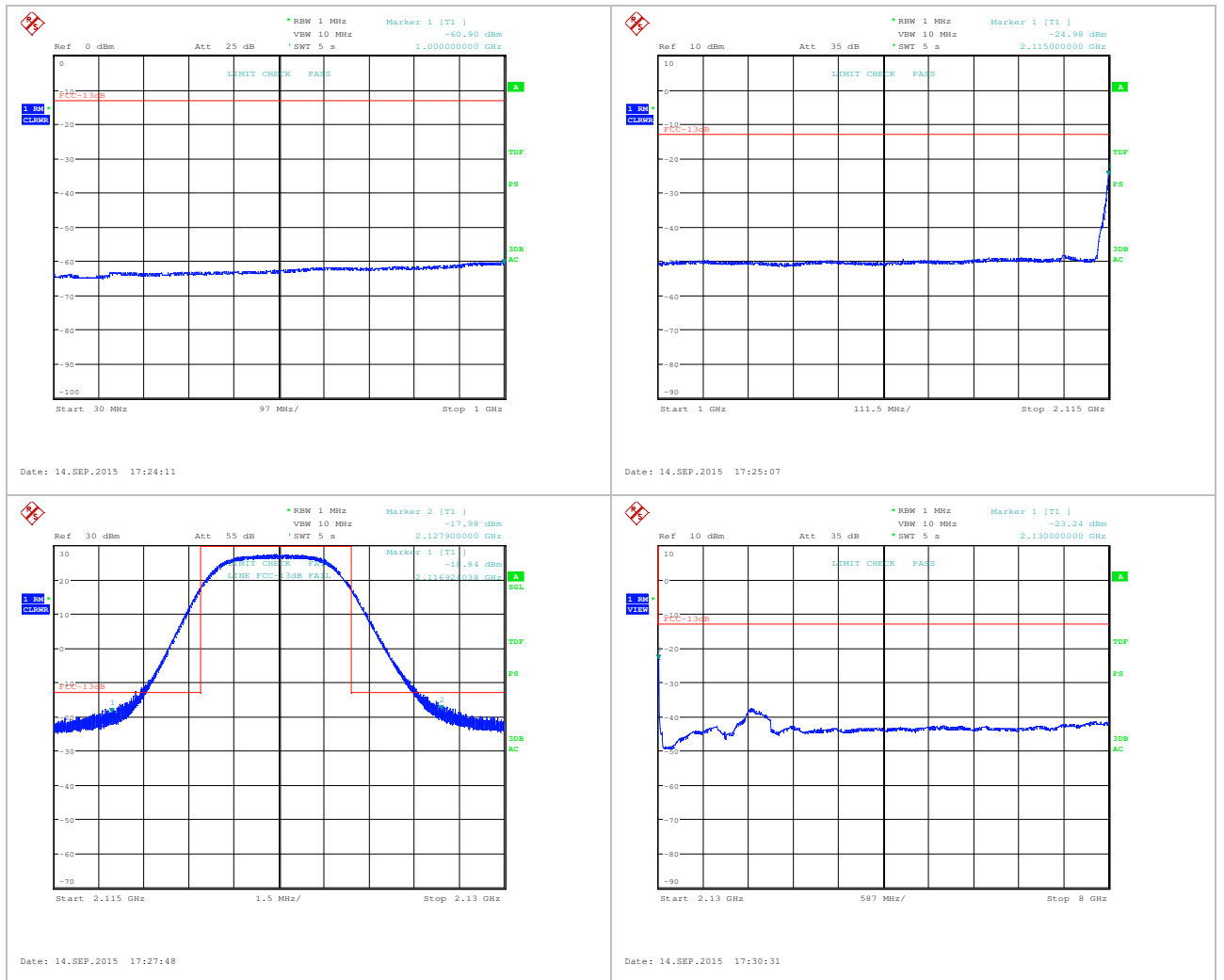

Figure 8: CSE plots: Ch 1587: 16QAM

12 Radiated Spurious Emissions

12.1 Requirement and test method

§ 90.1323 Emission limits.

(a) The power of any emission outside a licensee's frequency band(s) of operation shall be attenuated below the transmitter power (P) within the licensed band(s) of operation, measured in watts, by at least $43 + 10 \log(P)$ dB. Compliance with this provision is based on the use of measurement instrumentation employing a resolution bandwidth of 1 MHz or less, but at least one percent of the emission bandwidth of the fundamental emission of the transmitter, provided the measured energy is integrated over a 1 MHz bandwidth.

Industry Canada

RSS 139 section 6.5 Transmitter Unwanted Emissions

(i) In the first 1.0 MHz bands immediately outside and adjacent to the equipment's operating frequency block, the emission power per any 1% of the emission bandwidth shall be attenuated below the transmitter output power P (in watts) by at least $43 + 10 \log_{10}(P)$, dB.

(ii) After the first 1.0 MHz outside the equipment's operating frequency block, the emission power in any 1 MHz bandwidth shall be attenuated below the transmitter output power P (in watts) by at least $43 + 10 \log_{10}(P)$, dB.

Attenuation of $43+10\log(P)$ dBm equates to an absolute limit of -13dBm.

Pre-scan measurements were performed with a spectrum analyser, using a peak detector and resolution bandwidth of 1 MHz at a distance of 3m

The cabinet radiation was performed while antenna ports were terminated with 50Ω load.

Initial pre-scans were performed as follows:

30-1000 MHz – pre-scans were performed in a 3m chamber against a "pre-calibrated" limit of -13dBm ERP

1 – 4 GHz – pre-scans were performed in a 3m chamber against a "pre-calibrated" limit of -13dBm EIRP

4-22 GHz – pre-scans were performed in a 3m chamber against a field strength limit of 82.26 dBμV/mm which equates to -13dBm EIRP using formula $E = EIRP - 20\log D + 104.8$

Where pre-scans showed emissions within 20dB of the limit, final measurement was made using substitution method.

12.2 Results

Final pre-scans were performed and emissions maximised for any emissions within 20dB of the limit, a substitution test was performed which was only required for band edge:

Channel	Band-edge freq. (MHz)	EIRP (dBm)	Limit (dBm)	Results
1538	2110.1	-34.02	-13.0	Pass
	2115.1	-34.51	-13.0	Pass

12.3 Final pre-scans

Following initial pre-scans (below), final pre-scans were performed to identify worst case emissions.

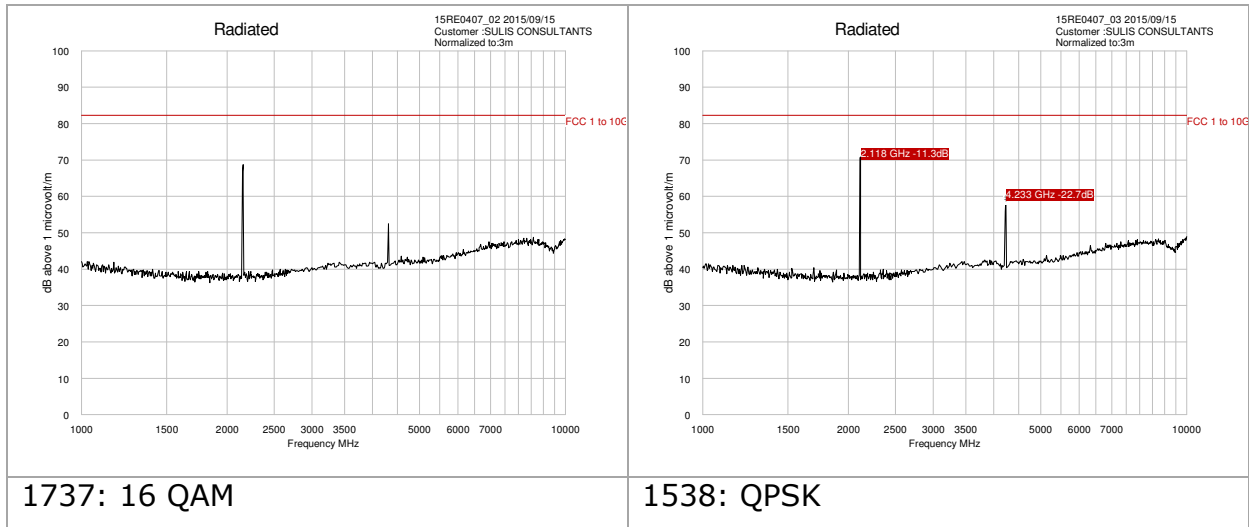

Substitution test performed for worst case fundamental emission, which was found to be > 20 dB below the limit.

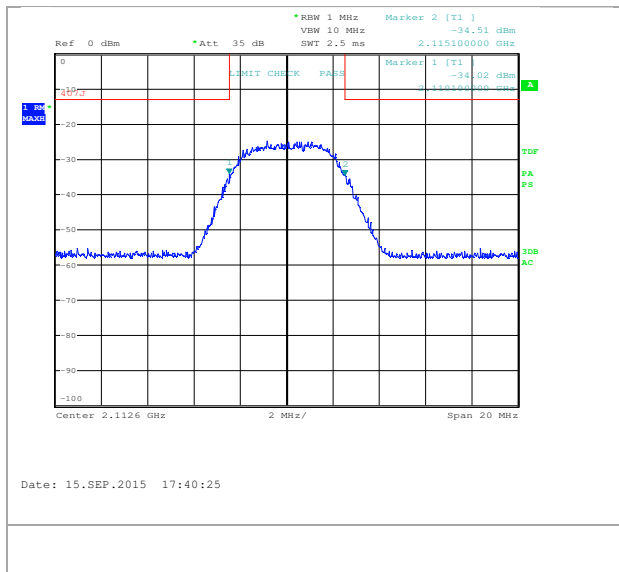

12.4 Initial pre-scans

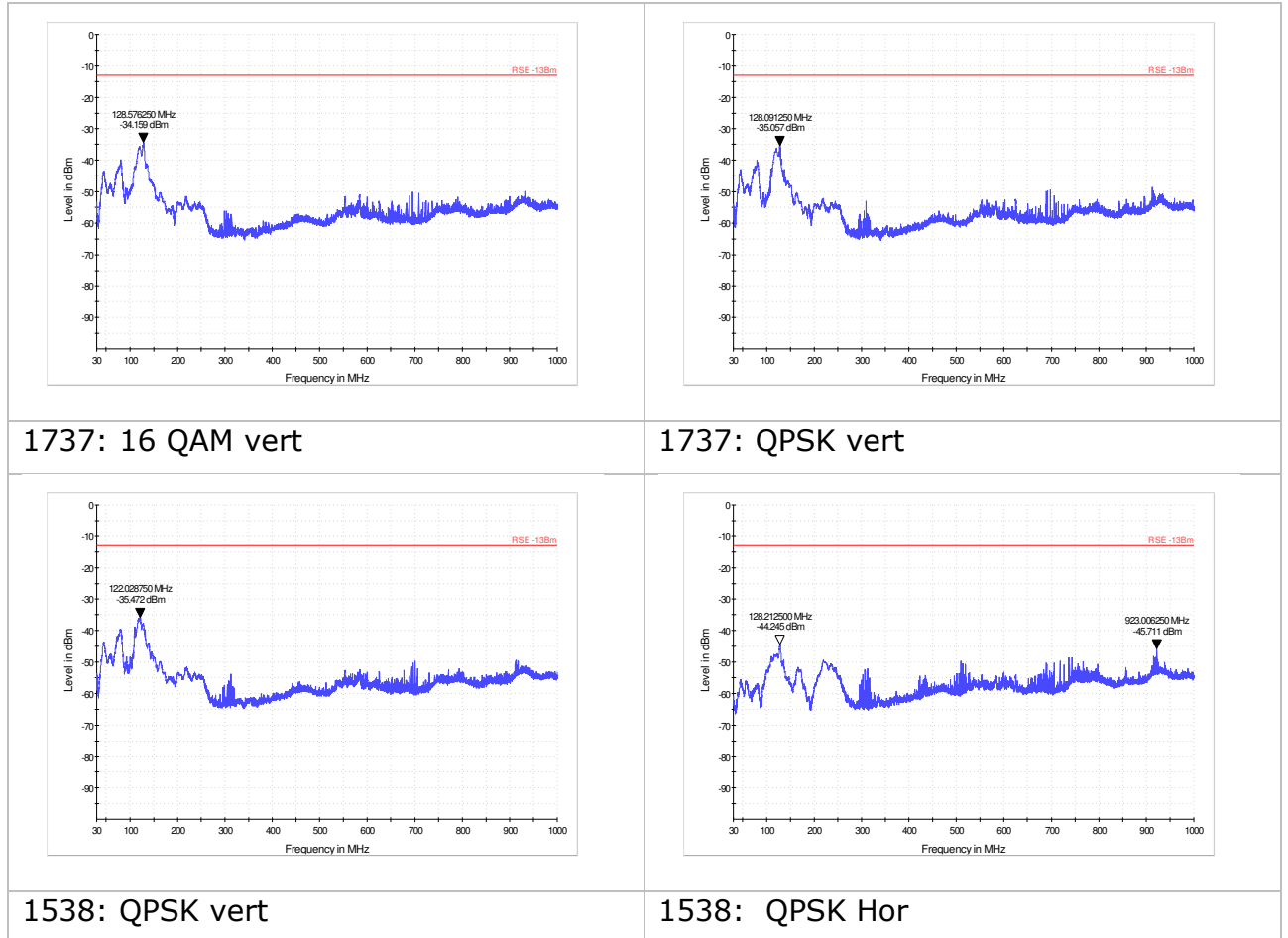
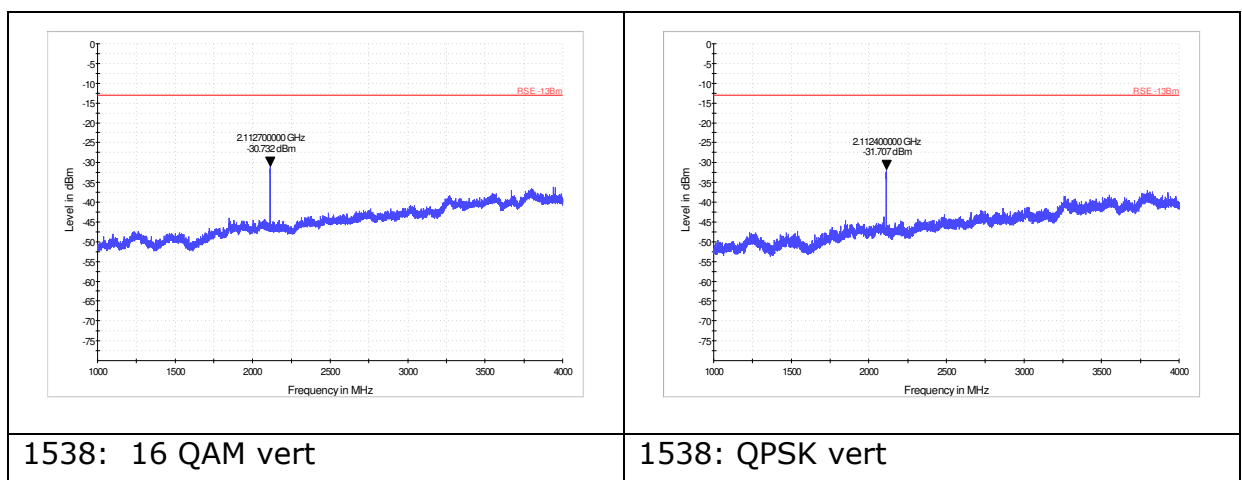

Figure 9: RSE pre-scans : 30-1000 MHz



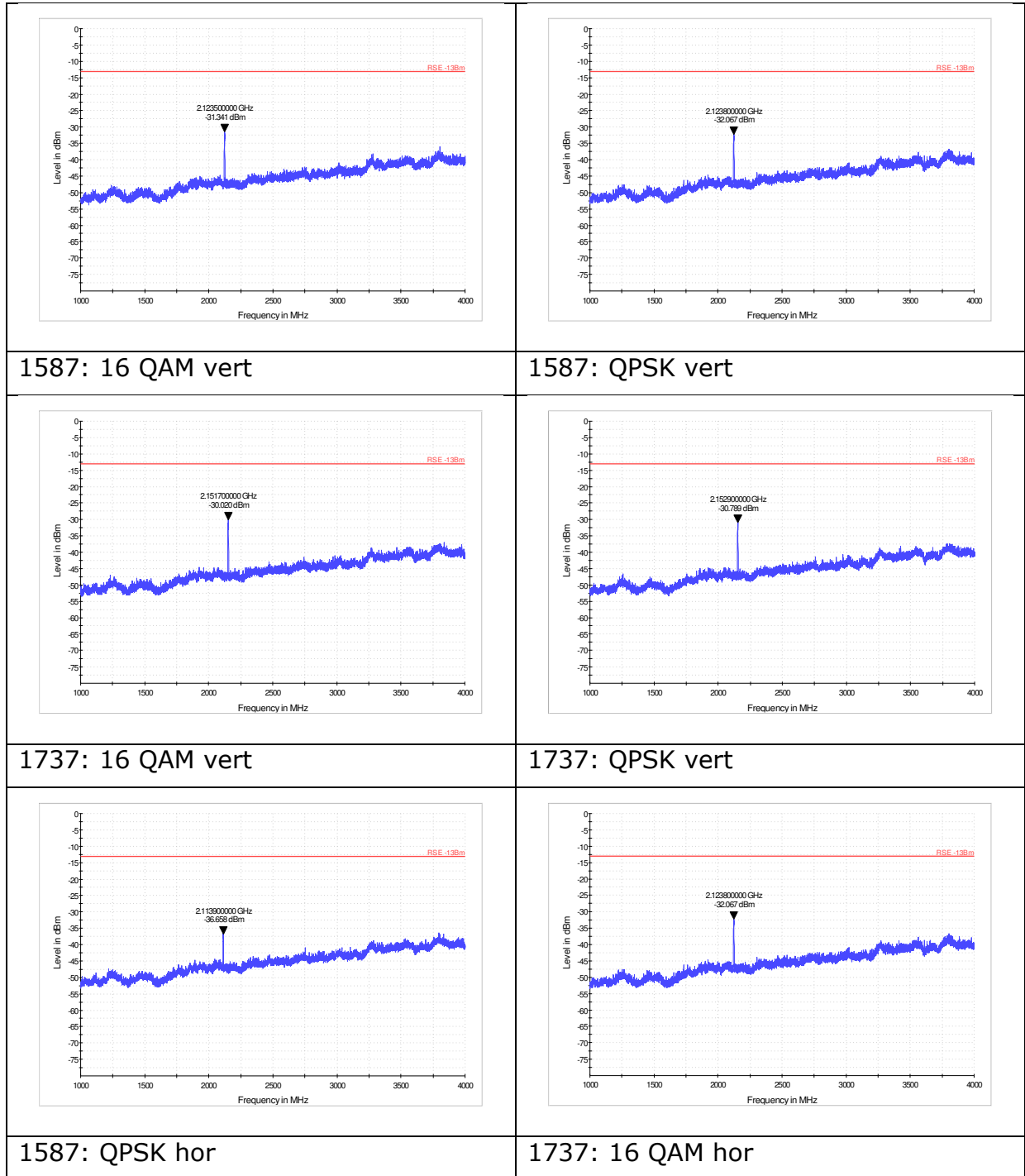

Figure 10: RSE pre-scans : 1 – 4 GHz

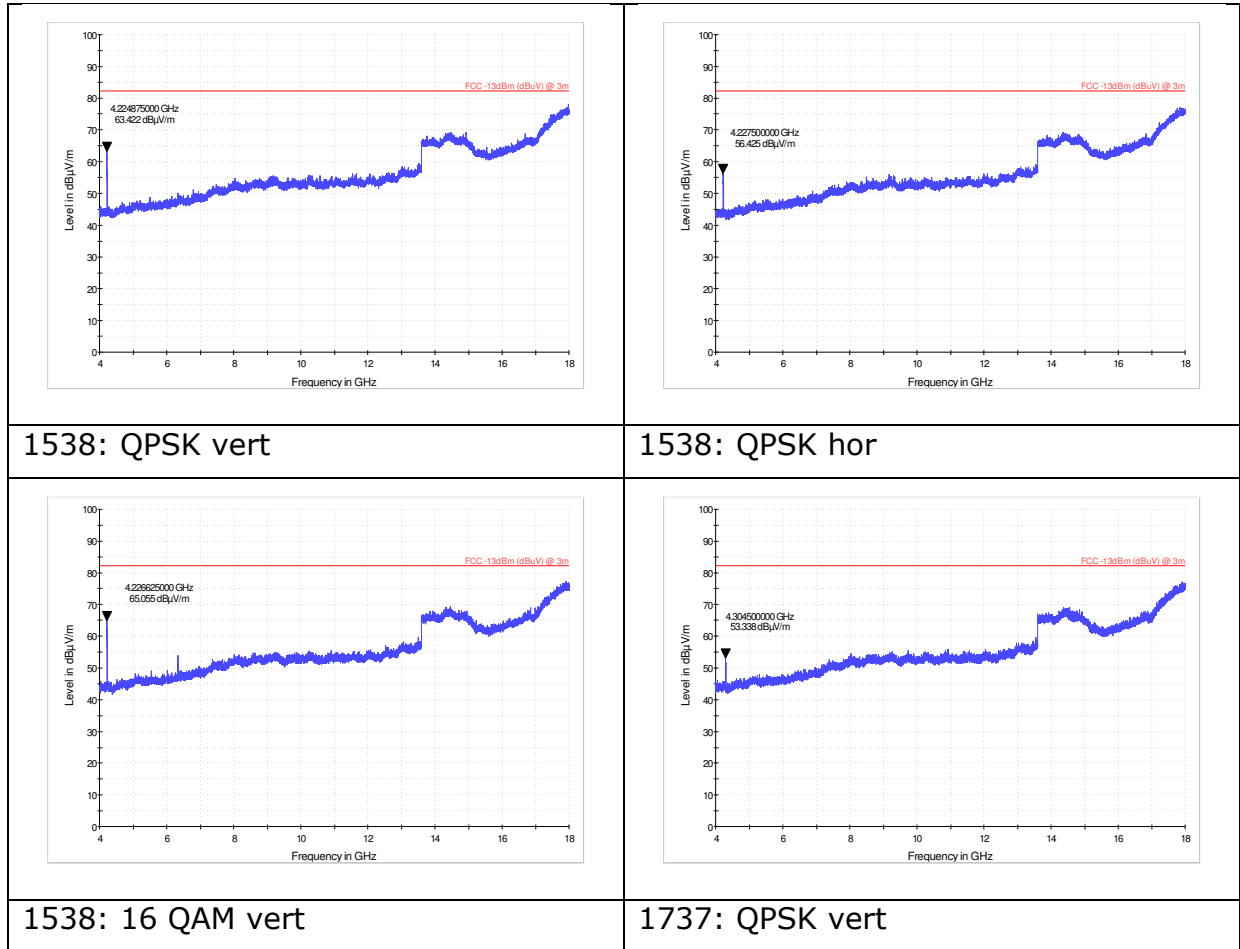

Figure 11: RSE pre-scans : 4 - 18 GHz

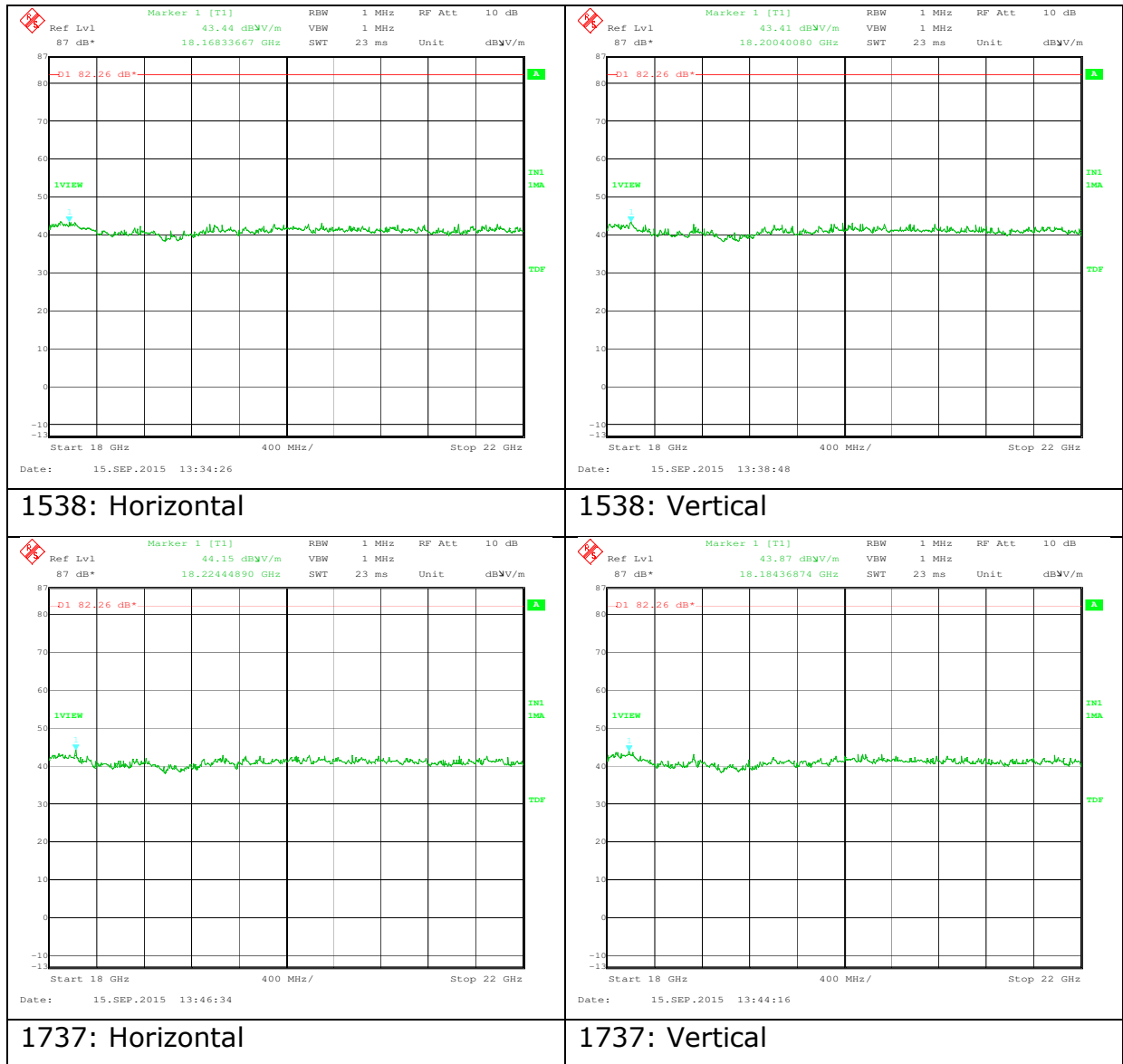

Figure 12: RSE pre-scans : 18 - 23 GHz

13 Test equipment and measurement uncertainty

Description	Manufacturer	Name	Serial Number	Calibration
Testing at Roke				
Spectrum Analyser	Rohde & Schwarz	FSP30	100219	R&S 1400-51419 CAL due 16-Apr-2016
Spectrum Analyser	Rohde & Schwarz	ESU8	100014	R&S 1400-50206 CAL due 02-Dec-2015
Signal Generator	HP	83732B	Us37101517	Agilent 1-5822069097-1 CAL due 20-Mar-2016
Antenna	Schaffner	CBL6112D	22608	Preliminary investigation only. Calibrated in-situ with above equipment
Pre-amp	Schwarzbeck	BBV9718	9718-003	
Antenna	ETS	3115	000444729	
Antenna	ETS	3115	00034811	
Cable	Sucoflex	Low loss	20796	Calibration checked prior to test
Cables	Gore	0QQ01Q011180	05108145 05108147	
Attenuator	Not stated	10dB	Not stated	
Testing at Hursley²				
Horn antenna	Q-par Angus	WBH218HN	5367	28/05/2016
Pre-amplifier	HP	8449B	3008A01077	02/07/2016
1-10GHz Horn	Schwarzbeck	BBHA 9120 571	571	29/01/2016
Test Receiver	R&S	ESI26	833362/006	26/06/2016
CISPR 7GHz Receiver	R&S	ESCI 7	100765	12/06/2016
Spectrum analyser	HP	8593EM	3710A00204	05/11/2015
Signal Generator	R&S	SMC100A	101214	15/10/2015
Signal generator	R&S	SMT06	830004/0012	24/07/2016

Table 10: Test Equipment

Description	Test	Measurement uncertainty
Spectrum Analyser	Conducted measurement	Instrument: $\pm 0.5\text{dB}$
Spectrum Analyser	Radiated Spurious Emissions	Set-up: $\pm 4.2\text{ dB}$

Table 11: Measurement uncertainty

² Calibration certificates held in accordance with UKAS accreditation.