



FCC Report

Application Purpose : Original grant
Applicant Name: : ICI Technology Shenzhen Co., Ltd.
FCC ID : 2AEZVASD-156E
Equipment Type : Android Signage Display
Model Name : ASD-156E
Report Number : FCC 15057307
Standard(S) : FCC Part 15 Subpart B ClassA
Date Of Receipt : May 29, 2015
Date Of Issue : June 8, 2015

Test By : 

(Neil Wong)

Reviewed By : 

(Robie Chen)

Authorized by : 

(Michal Ling)

Prepared by : **Shenzhen WST Testing Technology Co., Ltd.**
1F, No.9 Building, TGK Science & Technology Park Yangtian
Rd., NO.72 Bao'an Dist., Guangdong, China
(Registration Number: 939433)

REPORT REVISE RECORD

Report Version	Revise Time	Issued Date	Valid Version	Notes
V1.0	/	June 8, 2015	Valid	Original Report

Table of Contents	Page
1. GENERAL INFORMATION	4
2. TEST DESCRIPTION	6
2.1 MEASUREMENT UNCERTAINTY	6
2.2 DESCRIPTION OF TEST MODES	7
2.3 CONFIGURATION OF SYSTEM UNDER TEST	8
2.4 DESCRIPTION OF SUPPORT UNITS (CONDUCTED MODE)	8
3. SUMMARY OF TEST RESULTS	9
4. MEASUREMENT INSTRUMENTS	10
5. EMC EMISSION TEST	11
5.1 RADIATED EMISSION MEASUREMENT	11
5.1.1 RADIATED EMISSION LIMITS	11
5.1.2 TEST PROCEDURE	11
5.1.3 DEVIATION FROM TEST STANDARD	12
5.2.4 TEST SETUP	13
5.2.5 EUT OPERATING CONDITIONS	13
5.2.5.1 TEST RESULTS (BETWEEN 30M – 1000 MHZ)	14
5.2.5.2 TEST RESULTS(1GHZ TO 6GHZ)	16
6. EUT TEST PHOTO	17
7. PHOTOGRAPHS OF EUT	18

1. GENERAL INFORMATION

Test Model	ASD-156E
Applicant	ICI Technology Shenzhen Co., Ltd.
Address	2A826, Xinludao Building, Nanshan Street and Guimiao Road, Nanshan District, Shenzhen, Guangdong, China.
Manufacturer	SHENZHEN ENJOY TECHNOLOGY CO., LTD
Address	Room 309, JinLiHua Commercial Building, No. 1133, GongYuan Road, Block31, Bao'an District, Shenzhen, China
Equipment Type	Android Signage Display
Brand Name	N/A
EUT Power Rating	Input: DC12V 1200mA 14.4W
Data of receipt	May 29, 2015
Date of test	May 29, 2015 to June 8, 2015
Deviation	None
Condition of Test Sample	Normal

We hereby certify that:

All measurement facilities used to collect the measurement data are located at
1F, No.9 Building, TGK Science & Technology Park Yangtian Rd., NO.72 Bao'an Dist., Guangdong, China
The data evaluation, test procedures, and equipment configurations shown in this report were made in
accordance with the procedures given in ANSI C 63.4:2009. The sample tested as described in this report
is in compliance with the FCC Rules Part 15 Subpart B.

The test results of this report relate only to the tested sample identified in this report.

2. TEST DESCRIPTION

2.1 MEASUREMENT UNCERTAINTY

The reported uncertainty of measurement $y \pm U$, where expanded uncertainty U is based on a standard uncertainty multiplied by a coverage factor of $k=2$, providing a level of confidence of approximately **95 %**.

No.	Item	Uncertainty
1	Conducted Emission Test	$\pm 3.2\text{dB}$
2	RF power, conducted	$\pm 0.16\text{dB}$
3	Spurious emissions, conducted	$\pm 0.21\text{dB}$
4	All emissions, radiated(<1G)	$\pm 4.7\text{dB}$
5	All emissions, radiated(>1G)	$\pm 4.7\text{dB}$
6	Temperature	$\pm 0.5^\circ\text{C}$
7	Humidity	$\pm 2\%$

2.2 DESCRIPTION OF TEST MODES

To investigate the maximum EMI emission characteristics generated from EUT, the test system was pre-scanning tested based on the consideration of following EUT operation mode or test configuration mode which possibly have effect on EMI emission level. Each of these EUT operation mode(s) or test configuration mode(s) mentioned above was evaluated respectively.

Pretest Mode	Description
Mode 1	SD playing
Mode 2	USB playing

For Radiated Emission	
Final Test Mode	Description
Mode 1	SD playing

2.3 CONFIGURATION OF SYSTEM UNDER TEST

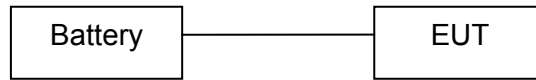

(EUT: Android Signage Display)

2.4 DESCRIPTION OF SUPPORT UNITS (CONDUCTED MODE)

The EUT has been tested as an independent unit together with other necessary accessories or support units. The following support units or accessories were used to form a representative test configuration during the tests.

Item	Equipment	Mfr/Brand	Model/Type No.	Series No.	Note
1	Battery	Jin Yue	38B20	/	/

Note:

- (1) The support equipment was authorized by Declaration of Confirmation.
- (2) For detachable type I/O cable should be specified the length in cm in 『Length』 column.

3. SUMMARY OF TEST RESULTS

Test procedures according to the technical standards:

FCC Part15 , Subpart B			
Standard Section	Test Item	Judgment	Remark
15.107	CONDUCTED EMISSION	N/A (Note 1)	/
15.109	RADIATED EMISSION	PASS	Class A (Note 2)

Note:

1. " N/A" denotes test is not applicable in this test report. There is no need for these tests for the product power is supplied by battery.
2. The EUT operation in a business environment

4. MEASUREMENT INSTRUMENTS

Kind of Equipment	Manufacturer	Type No.	Serial No.	Last Calibrated	Calibrated until
ESPI Test Receiver	R&S	ESPI	100379	08/19/2014	08/18/2015
pre-amplifier	CDSI	PAP-1G18-38	--	08/19/2014	08/18/2015
System Controller	CT	SC100	-	08/19/2014	08/18/2015
Bi-log Antenna	Chase	CBL6111C	2576	08/19/2014	08/18/2015
Spectrum analyzer	R&S	FSU26	200409	08/19/2014	08/18/2015
Horn Antenna	SCHWARZBECK	9120D	1141	08/19/2014	08/18/2015
Bi-log Antenna	Schwarebeck	VULB9163	9163/340	08/19/2014	08/18/2015
Pre Amplifier	H.P.	HP8447E	2945A02715	10/13/2014	10/12/2015
9*6*6 Anechoic	--	--	--	08/21/2014	08/20/2015

5. EMC EMISSION TEST

5.1 RADIATED EMISSION MEASUREMENT

5.1.1 RADIATED EMISSION LIMITS (Frequency Range 30MHz-1000MHz)

20dBc in any 100 kHz bandwidth outside the operating frequency band. In case the emission fall within the restricted band specified on 15.205(a), then the 15.209(a) limit in the table below has to be followed.

Frequencies (MHz)	Field Strength (micorvolts/meter)	Measurement Distance (meters)
30~88	300	3
88~216	500	3
216~960	700	3
Above 960	1000	3

LIMITS OF RADIATED EMISSION MEASUREMENT (Above 1000MHz)

FREQUENCY (MHz)	Limit (dBuV/m) (at 3M)	
	PEAK	AVERAGE
Above 1000	80	60

Notes:

- (1) The limit for radiated test was performed according to FCC PART 15B.
- (2) The tighter limit applies at the band edges.
- (3) Emission level (dBuV/m)=20log Emission level (uV/m).

Spectrum Parameter	Setting
Attenuation	Auto
Start Frequency	1000 MHz
Stop Frequency	10th carrier harmonic
RB / VB (emission in restricted band)	1 MHz / 1 MHz for Peak, 1 MHz / 10Hz for Average

Receiver Parameter	Setting
Attenuation	Auto
Start ~ Stop Frequency	30MHz~1000MHz / RB 120kHz for QP

5.1.2 TEST PROCEDURE

- a. The measuring distance of at 3 m shall be used for measurements at frequency up to 1GHz. For frequencies above 1GHz, any suitable measuring distance may be used.
- b. The EUT was placed on the top of a rotating table 0.8 meters above the ground at a 3 meter open area test site. The table was rotated 360 degrees to determine the position of the highest radiation.

- c. The height of the equipment or of the substitution antenna shall be 0.8 m; the height of the test antenna shall vary between 1 m to 4 m. Both horizontal and vertical polarizations of the antenna are set to make the measurement.
- d. The initial step in collecting conducted emission data is a spectrum analyzer peak detector mode pre-scanning the measurement frequency range. Significant peaks are then marked and then Quasi Peak detector mode re-measured.
- e. If the Peak Mode measured value compliance with and lower than Quasi Peak Mode Limit, the EUT shall be deemed to meet QP Limits and then no additional QP Mode measurement performed.
- f. For the actual test configuration, please refer to the related Item –EUT Test Photos.

Note:

***Both horizontal and vertical antenna polarities were tested
and the worst case emissions were reported***

5.1.3 DEVIATION FROM TEST STANDARD

No deviation

5.2.4 TEST SETUP

(A) Radiated Emission Test-Up Frequency 30MHz~1GHz

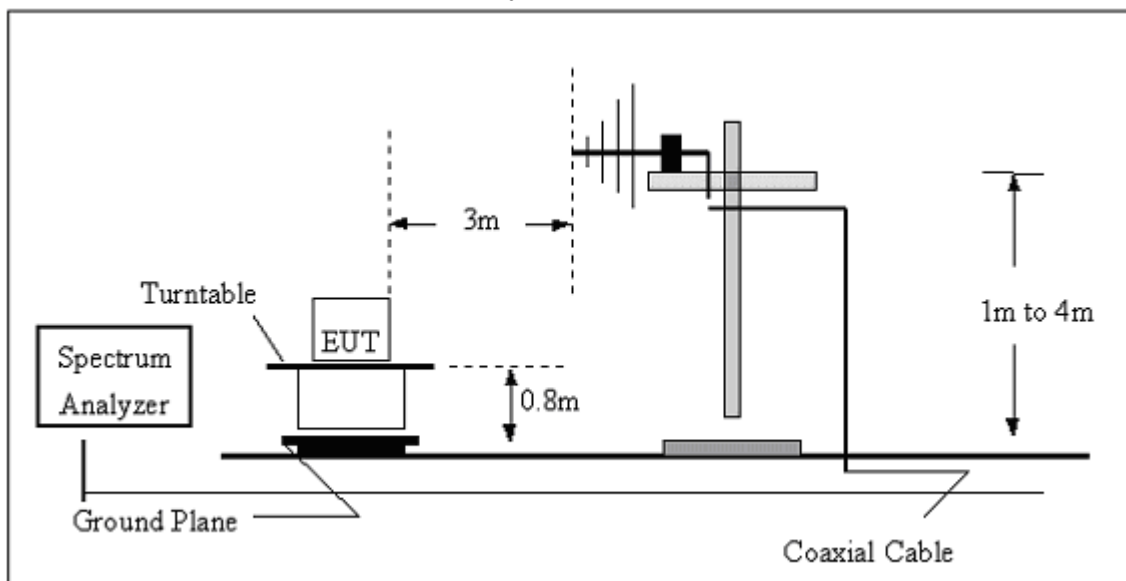

(B) Radiated Emission Test-Up Frequency Above 1GHz

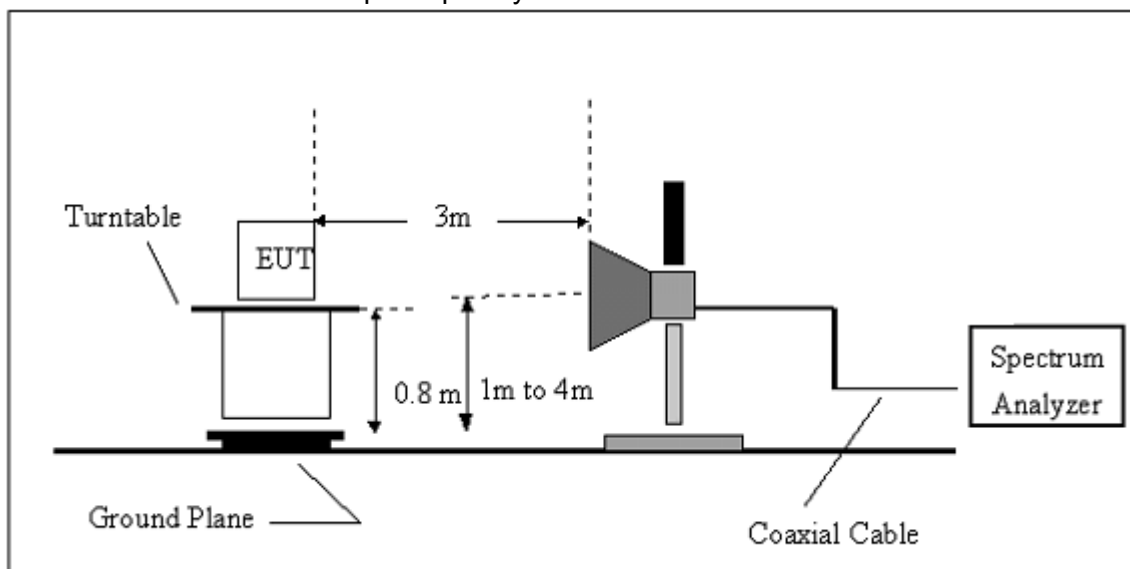

5.2.5 EUT OPERATING CONDITIONS

The EUT tested system was configured as the statements of 2.4 Unless otherwise a special operating condition is specified in the follows during the testing.

5.2.5.1 TEST RESULTS (BETWEEN 30M – 1000 MHZ)

EUT	Android Signage Display	Model Name	ASD-156CE
Temperature	20 °C	Relative Humidity	48%
Pressure	1010 hPa	Polarization :	Horizontal
Test Mode	Mode 1	Test Date	May 30, 2015

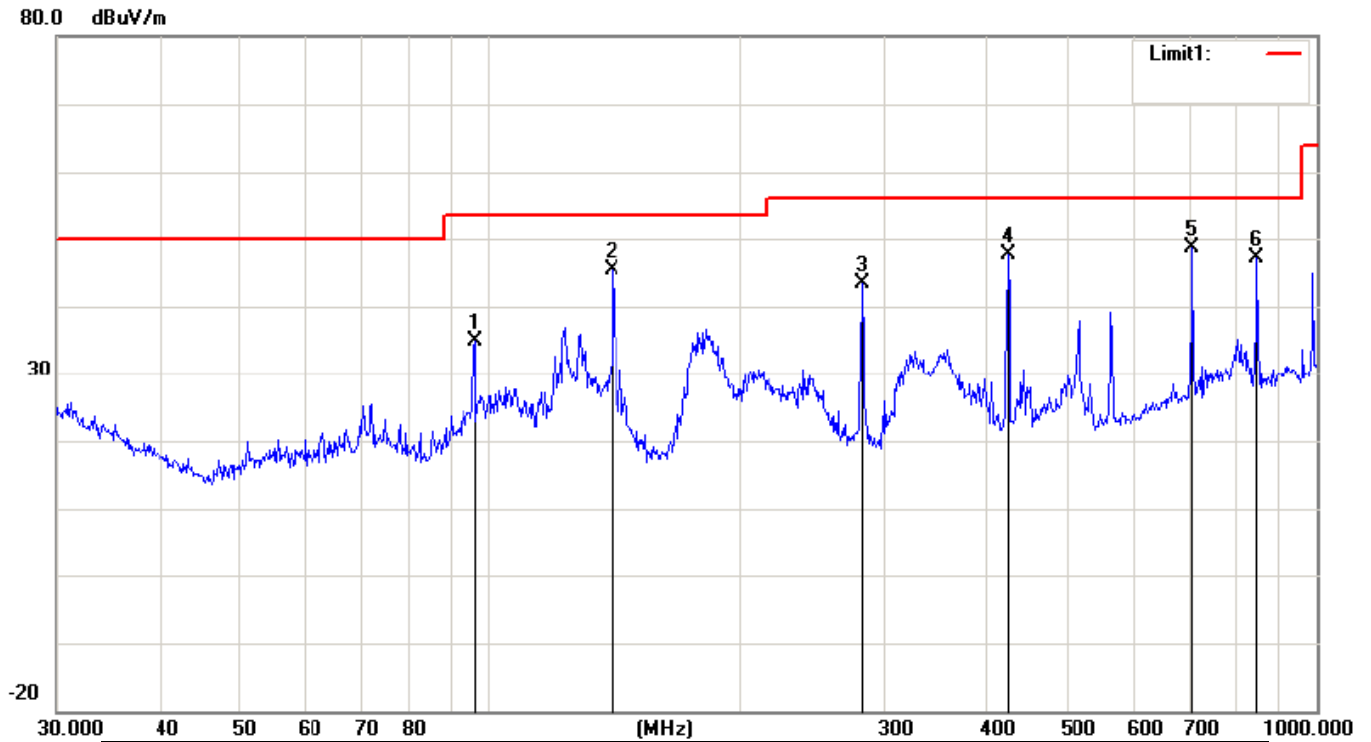

No.	Mk.	Freq. MHz	Reading Level dBuV	Correct Factor dB	Measure- ment dBuV/m	Limit dBuV/m	Over dB	Detector
1		96.0986	42.06	-7.12	34.94	53.50	-18.56	peak
2		140.8351	48.60	-3.13	45.47	53.50	-8.03	peak
3		281.9946	49.32	-6.05	43.27	56.00	-12.73	peak
4		423.5403	50.10	-2.42	47.68	56.00	-8.32	peak
5	*	706.6999	46.01	2.64	48.65	56.00	-7.35	peak
6		848.0563	42.31	4.82	47.13	56.00	-8.87	peak

EUT	Android Signage Display	Model Name	ASD-156CE
Temperature	20 °C	Relative Humidity	48%
Pressure	1010 hPa	Polarization :	Vertical
Test Mode	Mode 1	Test Date	May 30, 2015

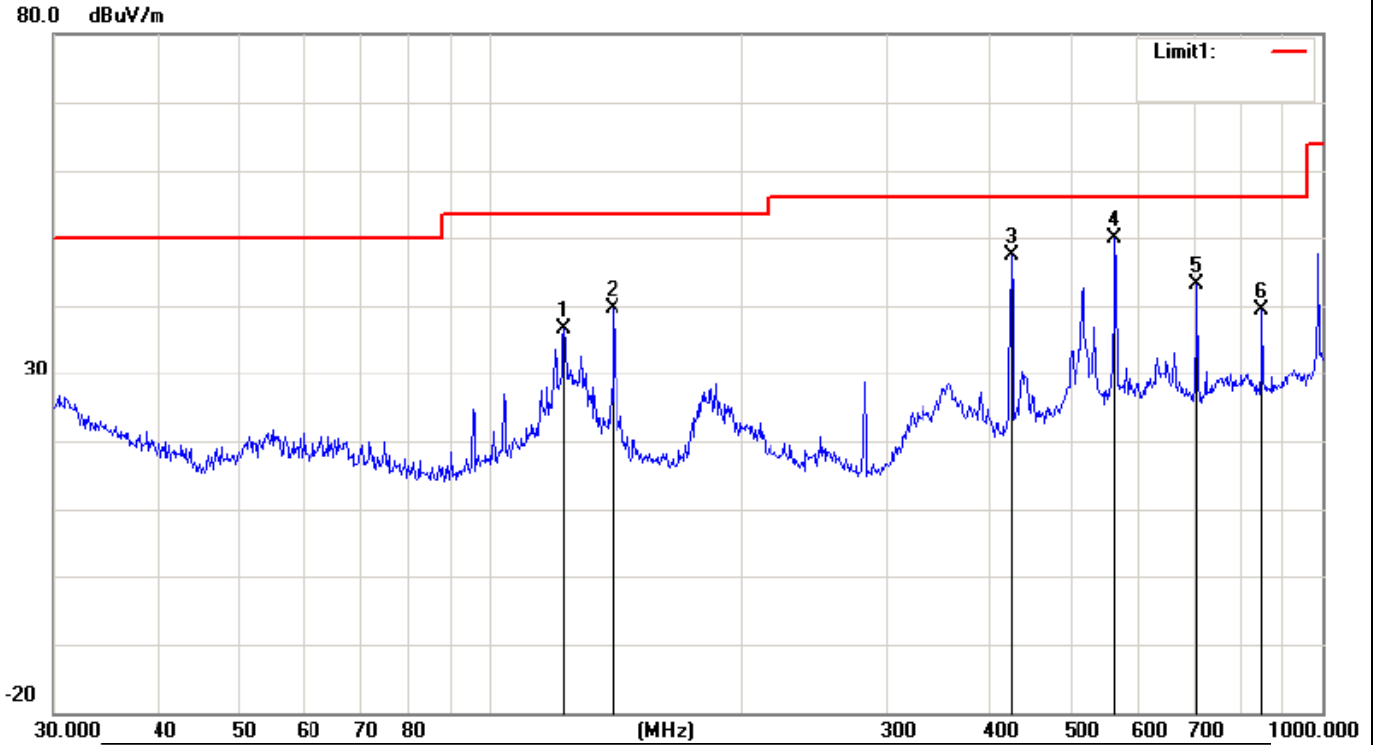

No.	Mk.	Freq. MHz	Reading Level dBuV	Correct Factor dB	Measure- ment dBuV/m	Limit dBuV/m	Over dB	Detector
1		122.8340	38.85	-2.22	36.63	53.50	-16.87	peak
2		140.8351	42.72	-3.13	39.59	53.50	-13.91	peak
3		423.5403	49.84	-2.42	47.42	56.00	-8.58	peak
4	*	564.6389	49.52	0.40	49.92	56.00	-6.08	peak
5		706.6999	40.53	2.64	43.17	56.00	-12.83	peak
6		848.0563	34.57	4.82	39.39	56.00	-16.61	peak

5.2.5.2 TEST RESULTS(1GHZ TO 6GHZ)

EUT	Android Signage Display	Model Name	ASD-156CE
Temperature	20 °C	Relative Humidity	48%
Pressure	1010 hPa	Test Mode	Mode 1
Test Date	May 30, 2015		

Freq. (MHz)	Ant. Pol.	Emission Level(dBuV)		Limit 3m(dBuV/m)		Over(dB)	
		PK	AV	PK	AV	PK	AV
1796.75	V	63.55	48.13	80	60	-16.45	-11.87
4728.19	V	66.86	48.14	80	60	-13.14	-11.86
1693.35	H	64.15	49.57	80	60	-15.85	-10.43
4872.59	H	67.52	50.76	80	60	-12.48	-9.24

Remark:

All emissions not reported were more than 20dB below the specified limit or in the noise floor.

Factor = Antenna Factor + Cable Loss – Pre-amplifier.

Only worst case is presented in this report.

6. EUT TEST PHOTO

RADIATED EMISSION TEST

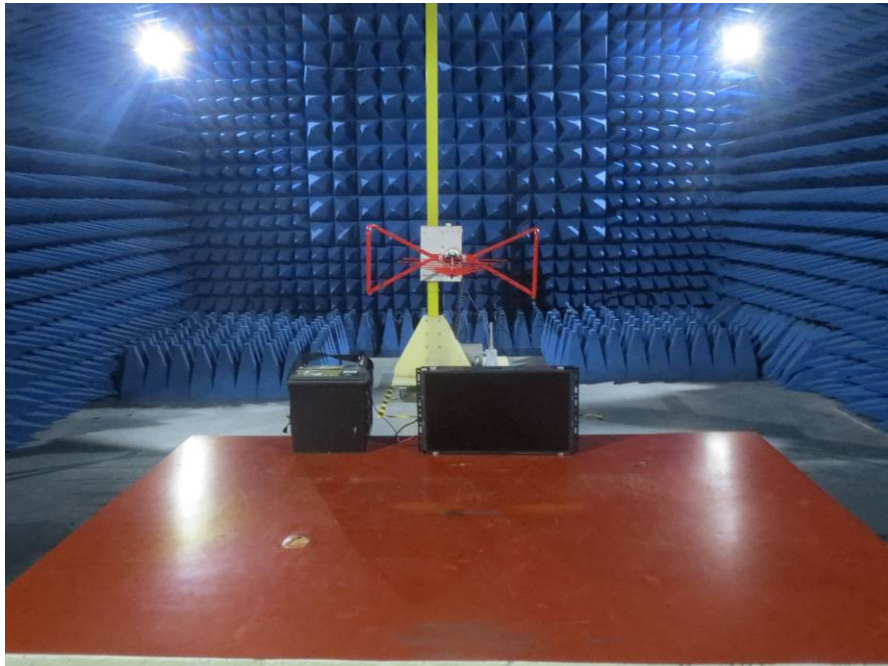

RADIATED EMISSION TEST

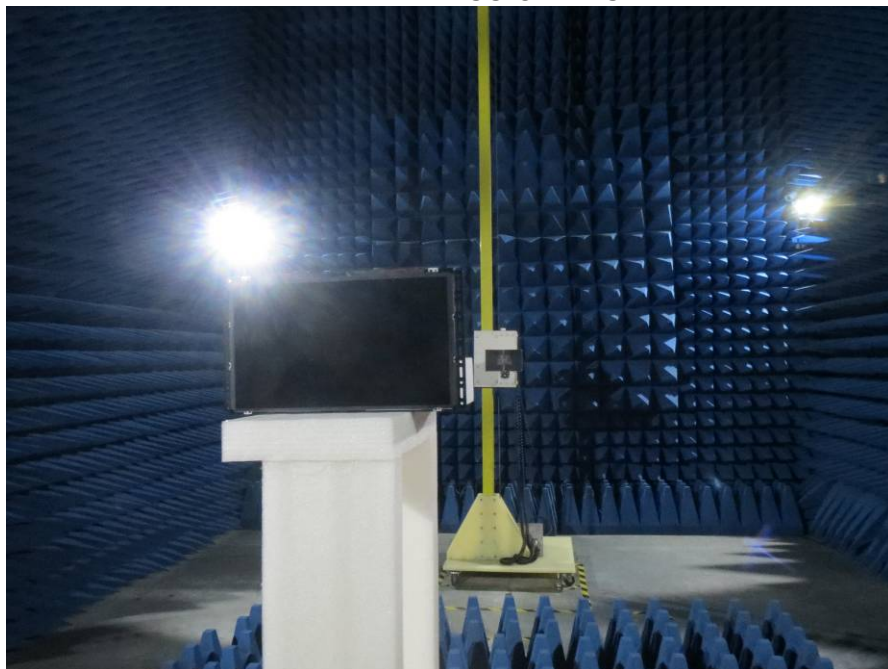

7. PHOTOGRAPHS OF EUT

Appearance photograph of EUT

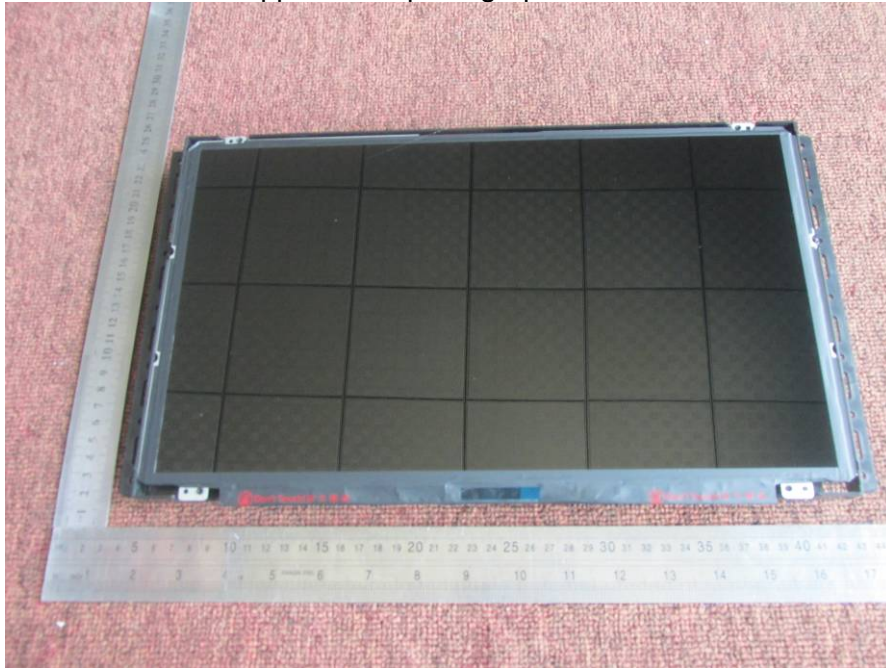

Appearance photograph of EUT



Appearance photograph of EUT



Appearance photograph of EUT



Appearance photograph of EUT



Appearance photograph of EUT



Internal photograph of EUT

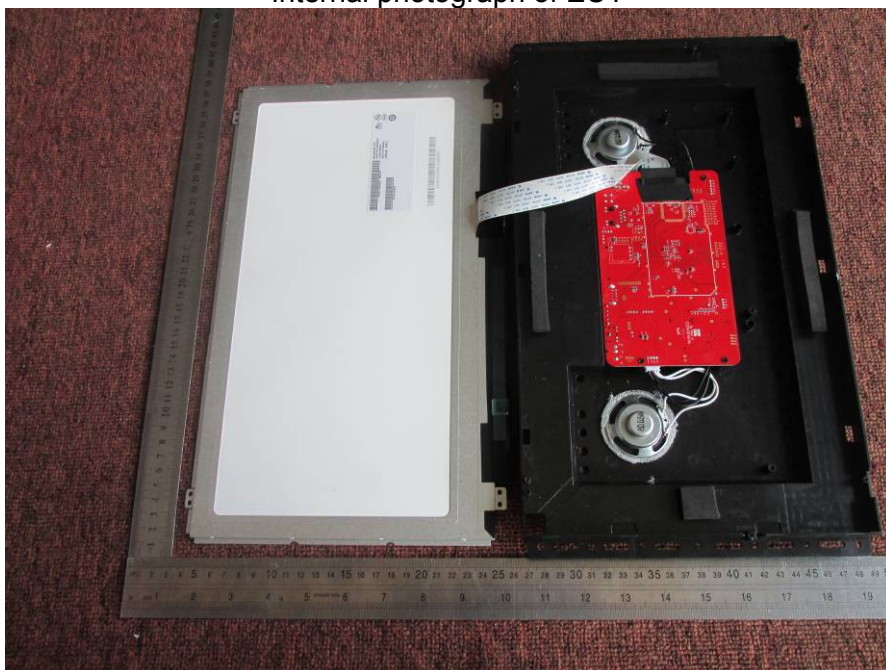

Internal photograph of EUT

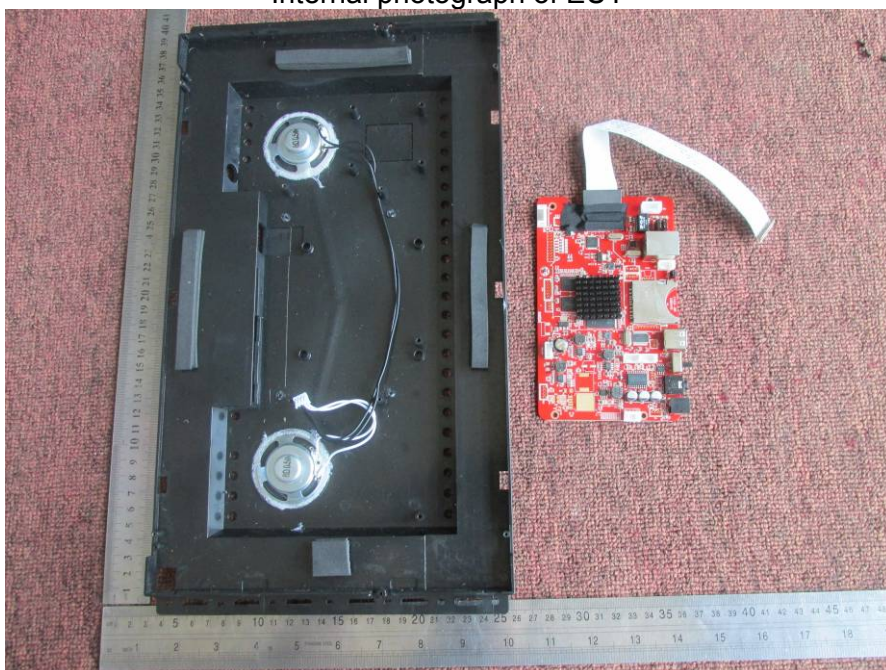

Internal photograph of EUT

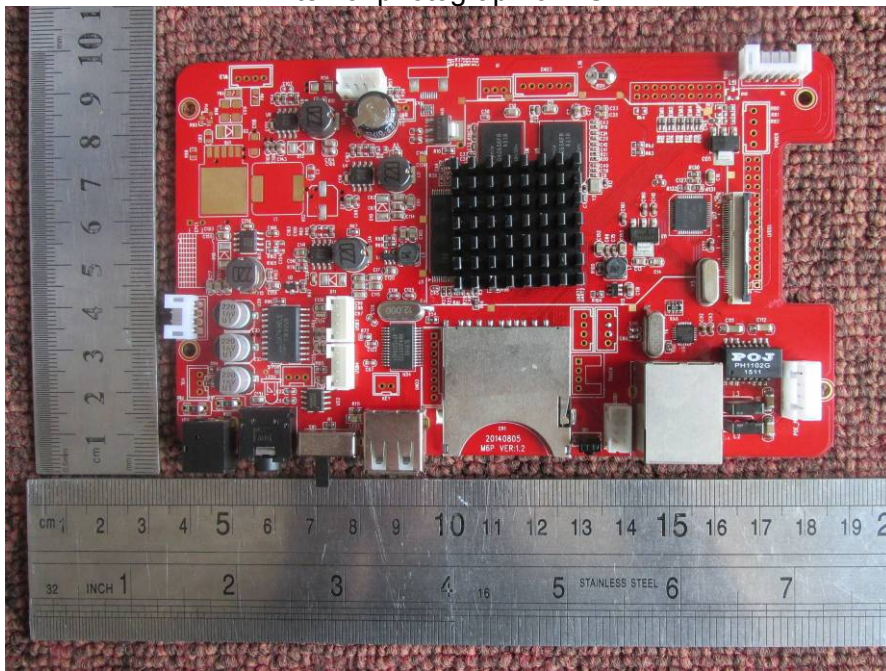

Internal photograph of EUT

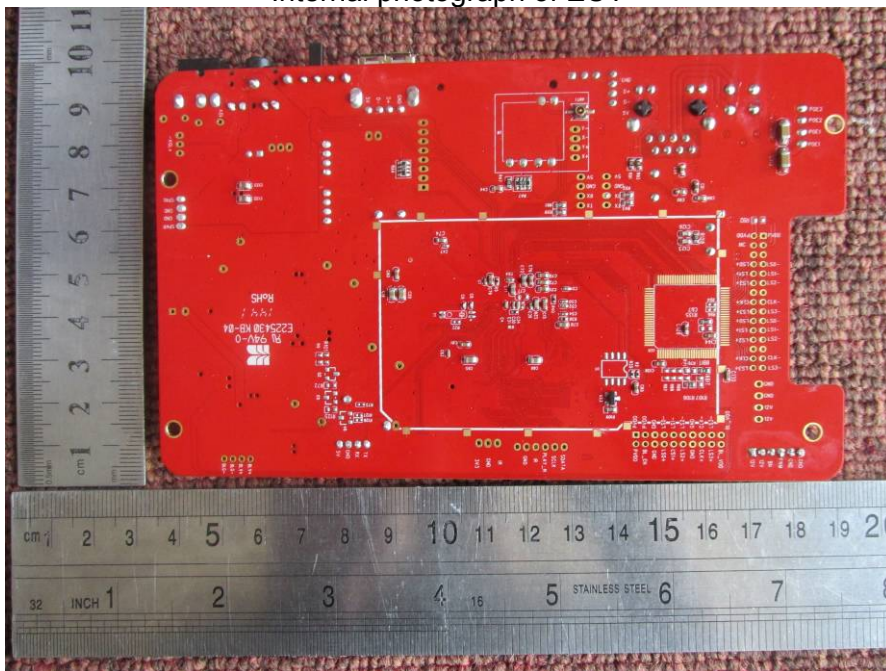

Internal photograph of EUT



Internal photograph of EUT



Internal photograph of EUT



Internal photograph of EUT



Internal photograph of EUT



Internal photograph of EUT

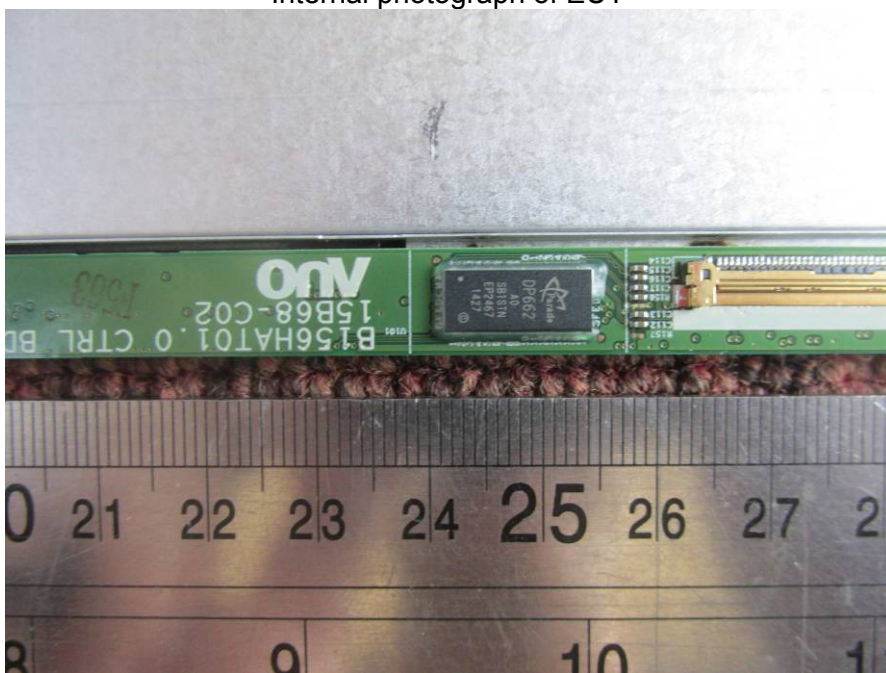

Internal photograph of EUT

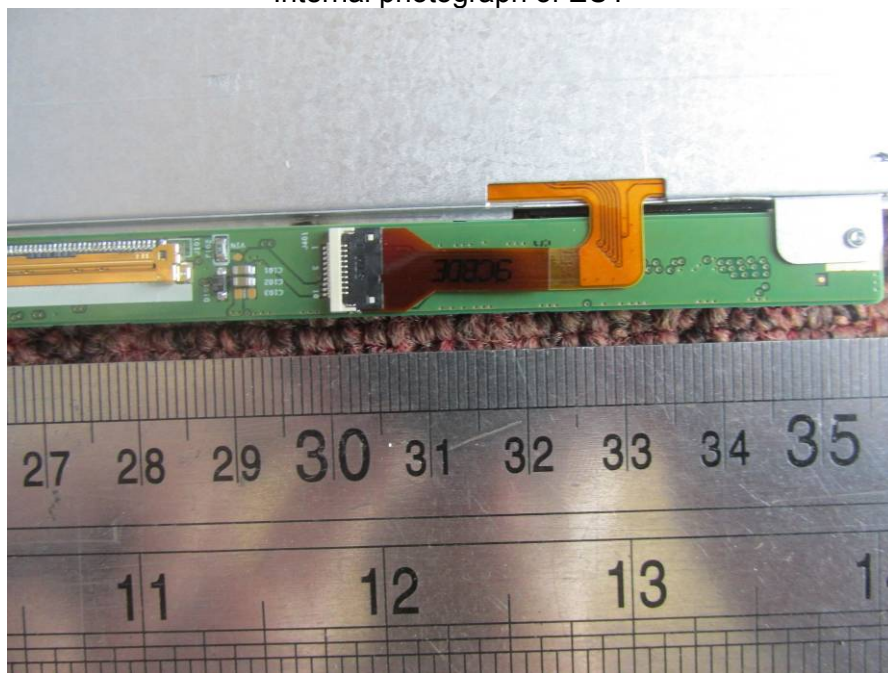

Internal photograph of EUT

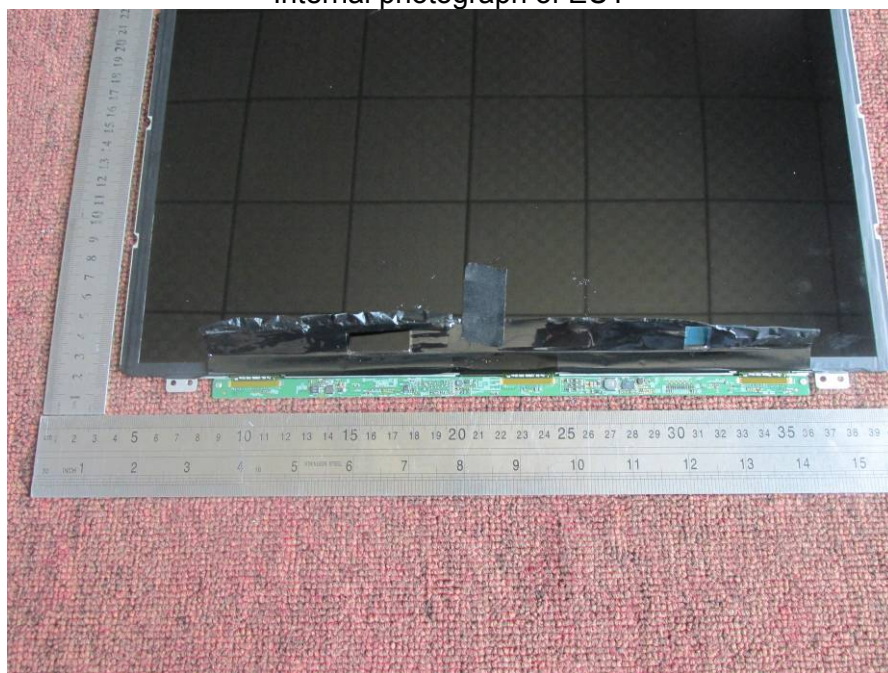

Internal photograph of EUT

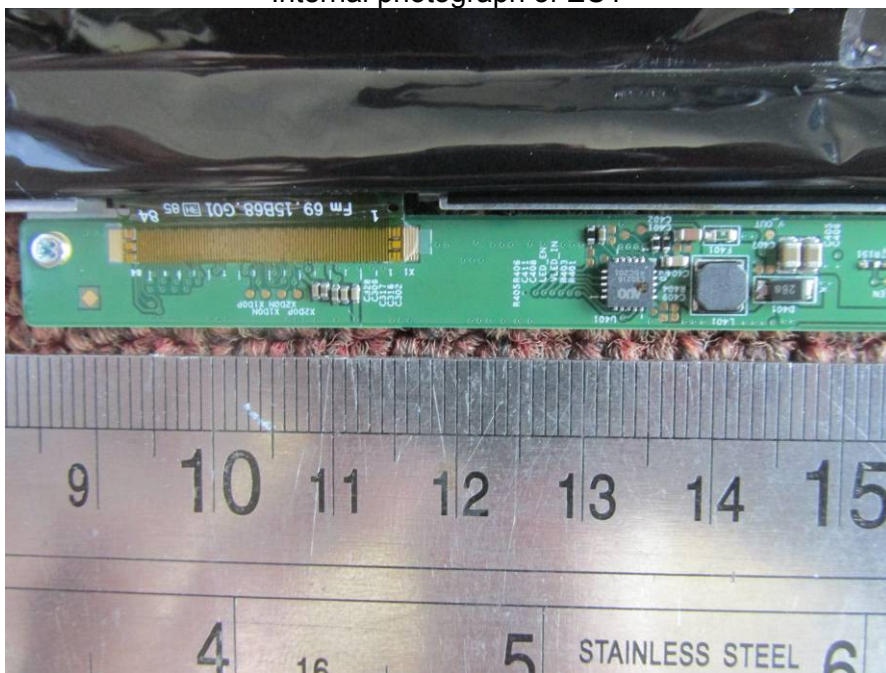

Internal photograph of EUT

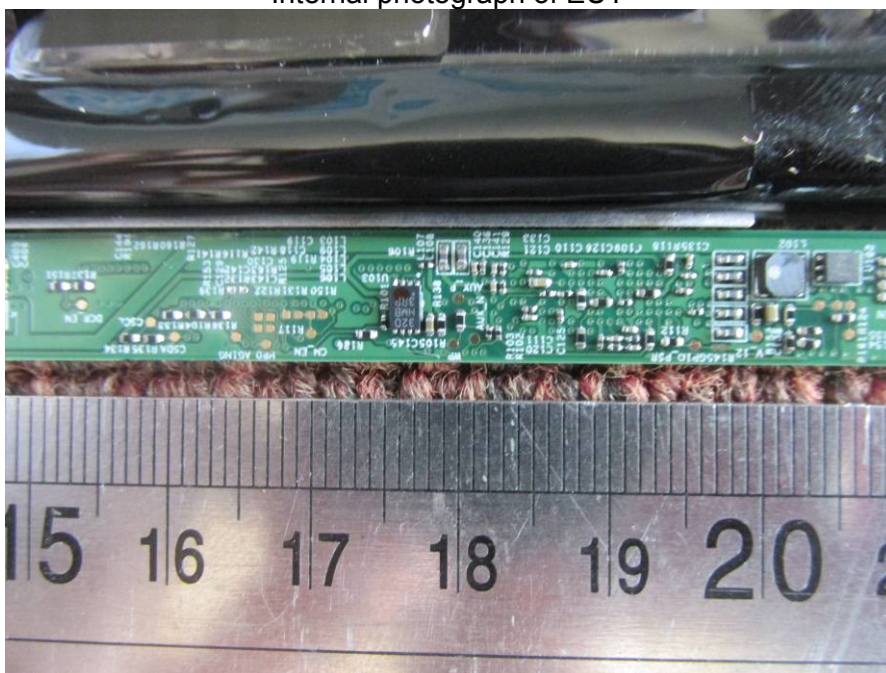

Internal photograph of EUT

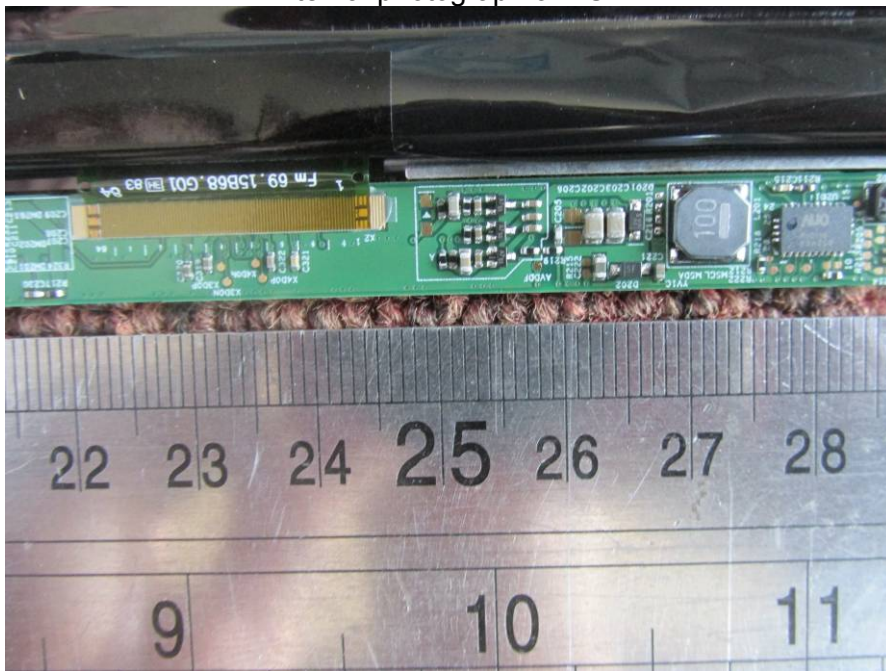

Internal photograph of EUT

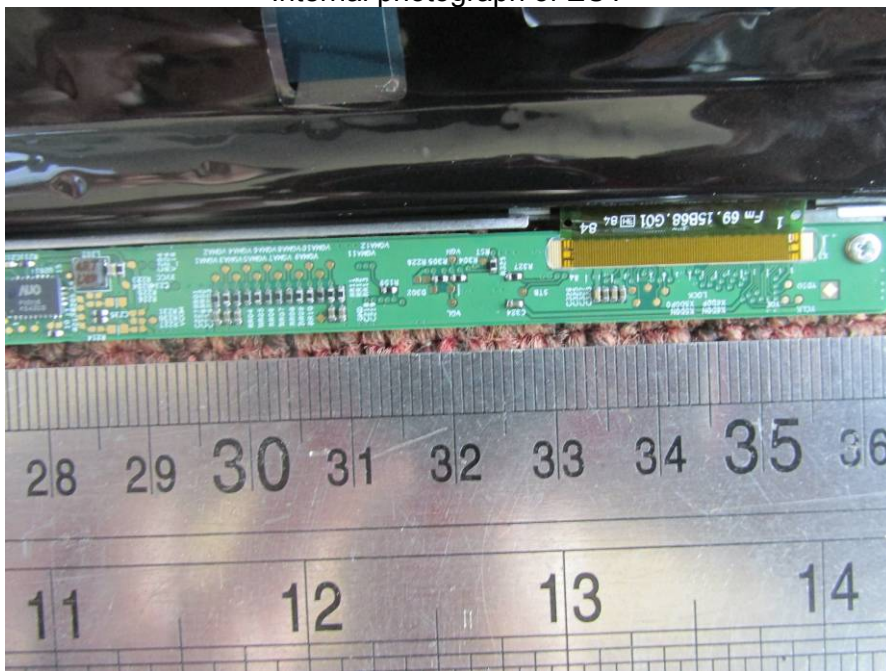

—END OF REPORT—