



Report No.: SER170918278002E



# RADIO TEST REPORT

## FCC ID: 2AEZV-ICI101T

**Product:** DIGITAL ADVERTISEMENT SCREEN  
**Trade Mark:** ICI  
**Model No.:** ICI101  
**Serial Model:** N/A  
**Report No.:** SER170918278002E  
**Issue Date:** 29 Sep. 2017

### Prepared for

ICI Technology Shenzhen Co., Ltd.  
2A826, Xinludao Building, Nanshan Street and Guimiao Road, Nanshan  
District, Shenzhen, China.

### Prepared by

Shenzhen NTEK Testing Technology Co., Ltd.  
1/F, Building E, Fenda Science Park, Sanwei Community,  
Xixiang Street Bao'an District, Shenzhen 518126 P.R. China  
Tel.: +86-755-6115 9388  
Fax.: +86-755-6115 6599  
Website: <http://www.ntek.org.cn>



### TABLE OF CONTENTS

- 1 TEST RESULT CERTIFICATION .....3**
- 2 SUMMARY OF TEST RESULTS.....4**
- 3 FACILITIES AND ACCREDITATIONS .....5**
  - 3.1 FACILITIES.....5
  - 3.2 LABORATORY ACCREDITATIONS AND LISTINGS .....5
  - 3.3 MEASUREMENT UNCERTAINTY .....5
- 4 GENERAL DESCRIPTION OF EUT .....6**
- 5 DESCRIPTION OF TEST MODES .....8**
- 6 SETUP OF EQUIPMENT UNDER TEST .....9**
  - 6.1 BLOCK DIAGRAM CONFIGURATION OF TEST SYSTEM.....9
  - 6.2 SUPPORT EQUIPMENT.....10
  - 6.3 EQUIPMENTS LIST FOR ALL TEST ITEMS.....11
- 7 TEST REQUIREMENTS .....13**
  - 7.1 CONDUCTED EMISSIONS TEST .....13
  - 7.2 RADIATED SPURIOUS EMISSION .....22



### 1 TEST RESULT CERTIFICATION

Applicant's name .....	ICI Technology Shenzhen Co., Ltd.
Address .....	2A826, Xinludao Building, Nanshan Street and Guimiao Road, Nanshan District, Shenzhen, China.
Manufacturer's Name .....	ICI Technology Shenzhen Co., Ltd.
Address .....	2A826, Xinludao Building, Nanshan Street and Guimiao Road, Nanshan District, Shenzhen, China.
Product description	
Product name .....	DIGITAL ADVERTISEMENT SCREEN
Model and/or type reference .....	ICI101
Serial Model .....	N/A

Measurement Procedure Used:

APPLICABLE STANDARDS	
APPLICABLE STANDARD/ TEST PROCEDURE	TEST RESULT
FCC 47 CFR Part 2, Subpart J FCC 47 CFR Part 15, Subpart C KDB 174176 D01 Line Conducted FAQ v01r01 ANSI C63.10-2013 FCC KDB 558074 D01 DTS Meas Guidance v04	Complied

This device described above has been tested by Shenzhen NTEK Testing Technology Co., Ltd., and the test results show that the equipment under test (EUT) is in compliance with the FCC requirements. And it is applicable only to the tested sample identified in the report.

This report shall not be reproduced except in full, without the written approval of Shenzhen NTEK Testing Technology Co., Ltd., this document may be altered or revised by Shenzhen NTEK Testing Technology Co., Ltd., personnel only, and shall be noted in the revision of the document.

The test results of this report relate only to the tested sample identified in this report.

Date of Test : 14 Jun. 2017 ~ 29 Sep 2017

Testing Engineer : Susan Su  
(Susan Su)

Technical Manager : Jason Chen  
(Jason Chen)

Authorized Signatory : Sam. Chen  
(Sam Chen)



## 2 SUMMARY OF TEST RESULTS

FCC Part15 (15.247), Subpart C			
Standard Section	Test Item	Verdict	Remark
15.207	Conducted Emission	PASS	
15.247 (a)(2)	6dB Bandwidth	N/A	
15.247 (b)	Peak Output Power	N/A	
15.247 (c)	Radiated Spurious Emission	PASS	
15.247 (d)	Power Spectral Density	N/A	
15.205	Band Edge Emission	N/A	
15.203	Antenna Requirement	N/A	

Remark:

1. "N/A" denotes test is not applicable in this Test Report.
2. All test items were verified and recorded according to the standards and without any deviation during the test.
3. This EUT has also been tested and complied with the requirements of FCC Part 15, Subpart B, recorded in a separate test report.

### 3 FACILITIES AND ACCREDITATIONS

#### 3.1 FACILITIES

All measurement facilities used to collect the measurement data are located at 1/F, Building E, Fenda Science Park, Sanwei Community, Xixiang Street, Bao'an District, Shenzhen 518126 P.R. China.

The sites are constructed in conformance with the requirements of ANSI C63.7, ANSI C63.10 and CISPR Publication 22.

#### 3.2 LABORATORY ACCREDITATIONS AND LISTINGS

Site Description

CNAS-Lab. : Accredited by CNAS, 2014.09.04  
 The Laboratory has been assessed and proved to be in compliance with CNAS-CL01:2006 (identical to ISO/IEC 17025:2005)  
 The Certificate Registration Number is L5516.

IC-Registration : Accredited by Industry Canada, August 29, 2012  
 The Certificate Registration Number is 9270A-1.

FCC- Accredited : Test Firm Registration Number: 463705.  
 Designation Number: CN1184

A2LA-Lab. : The Certificate Registration Number is 4298.01  
 This laboratory is accredited in accordance with the recognized International Standard ISO/IEC 17025:2005 General requirements for the competence of testing and calibration laboratories.  
 This accreditation demonstrates technical competence for a defined scope and the operation of a laboratory quality management system (refer to joint ISO-ILAC-IAF Communiqué dated 8 January 2009).

Name of Firm : Shenzhen NTEK Testing Technology Co., Ltd.

Site Location : 1/F, Building E, Fenda Science Park, Sanwei Community, Xixiang Street, Bao'an District, Shenzhen 518126 P.R. China.

#### 3.3 MEASUREMENT UNCERTAINTY

The reported uncertainty of measurement  $y \pm U$ , where expanded uncertainty  $U$  is based on a standard uncertainty multiplied by a coverage factor of  $k=2$ , providing a level of confidence of approximately 95 %.

No.	Item	Uncertainty
1	Conducted Emission Test	$\pm 2.80\text{dB}$
2	RF power, conducted	$\pm 0.16\text{dB}$
3	Spurious emissions, conducted	$\pm 0.21\text{dB}$
4	All emissions, radiated(30MHz~1GHz)	$\pm 2.64\text{dB}$
5	All emissions, radiated(1GHz~6GHz)	$\pm 2.40\text{dB}$
6	All emissions, radiated(>6GHz)	$\pm 2.52\text{dB}$
7	Temperature	$\pm 0.5^\circ\text{C}$
8	Humidity	$\pm 2\%$



#### 4 GENERAL DESCRIPTION OF EUT

Product Feature and Specification	
Equipment	DIGITAL ADVERTISEMENT SCREEN
Trade Mark	ICI
FCC ID	2AEZV-ICI101T
Model No.	ICI101
Serial Model	N/A
Model Difference	N/A
Operating Frequency	2402MHz~2480MHz
Modulation	GFSK
Number of Channels	40 Channels
Bluetooth Version	BT V4.0(BLE)
Antenna Type	External Antenna
Antenna Gain	3 dBi
Power supply	<input checked="" type="checkbox"/> DC supply: DC 12V from adapter or DC 48V from POE
	<input type="checkbox"/> Adapter supply:
HW Version	N/A
SW Version	N/A

Note: Based on the application, features, or specification exhibited in User's Manual, the EUT is considered as an ITE/Computing Device. More details of EUT technical specification, please refer to the User's Manual.



### Revision History

Report No.	Version	Description	Issued Date
SER170918278002E	Rev.01	Initial issue of report	Sep 29, 2017

## 5 DESCRIPTION OF TEST MODES

To investigate the maximum EMI emission characteristics generated from EUT, the test system was pre-scanning tested based on the consideration of following EUT operation mode or test configuration mode which possibly have effect on EMI emission level. Each of these EUT operation mode(s) or test configuration mode(s) mentioned above was evaluated respectively.

The Transmitter was operated in the normal operating mode. The TX frequency was fixed which was for the purpose of the measurements.

Test of channel included the lowest and middle and highest frequency to perform the test, then record on this report.

Those data rates (1Mbps for GFSK modulation) were used for all test.

The EUT was pretested with 3 orientations placed on the table for the radiated emission measurement –X, Y, and Z-plane. The X-plane results were found as the worst case and were shown in this report.

Carrier Frequency and Channel list:

Channel	Frequency(MHz)
0	2402
1	2404
...	...
19	2440
20	2442
...	...
38	2478
39	2480

Note:  $fc=2402MHz+k \times 2MHz$   $k=0$  to 39

The following summary table is showing all test modes to demonstrate in compliance with the standard.

Test Cases	
Test Item	Data Rate/ Modulation
	Bluetooth 4.0_LE / GFSK
AC Conducted Emission	Mode 1: normal link mode
Radiated Test Cases	Mode 1: normal link mode
Conducted Test Cases	

Note:

1. The engineering test program was provided and the EUT was programmed to be in continuously transmitting mode.
2. AC power line Conducted Emission was tested under maximum output power.
3. For radiated test cases, the worst mode data rate 1Mbps was reported only, because this data rate has the highest RF output power at preliminary tests, and no other significantly frequencies found in conducted spurious emission.
4. EUT is set to continuous transmission mode. duty cycle greater than 98%.



## 6 SETUP OF EQUIPMENT UNDER TEST

### 6.1 BLOCK DIAGRAM CONFIGURATION OF TEST SYSTEM

For AC Conducted Emission Mode(Adapter)

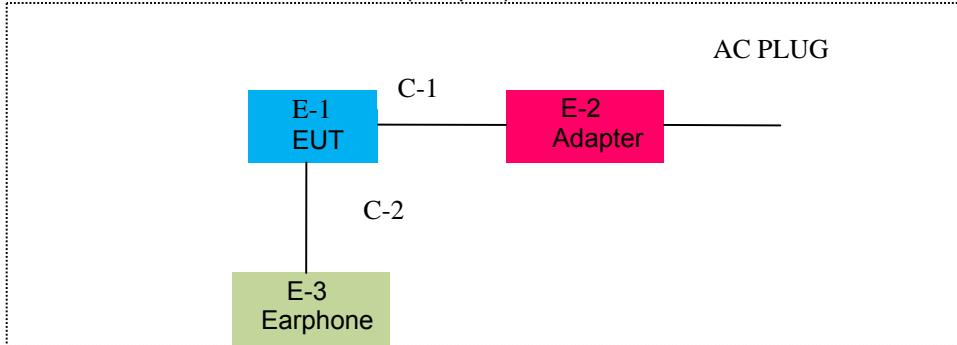

For AC Conducted Emission Mode(POE)

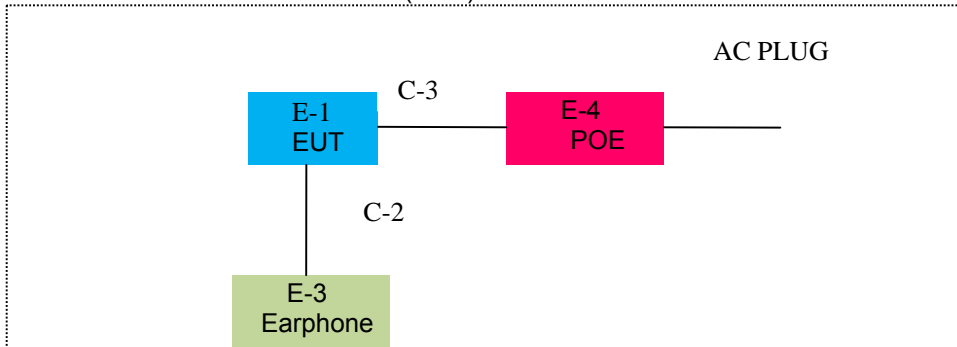

For Radiated Test Cases(Adapter)

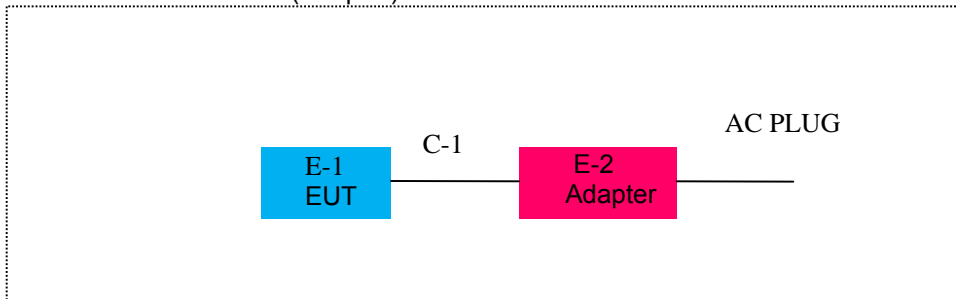

For Radiated Test Cases(POE)

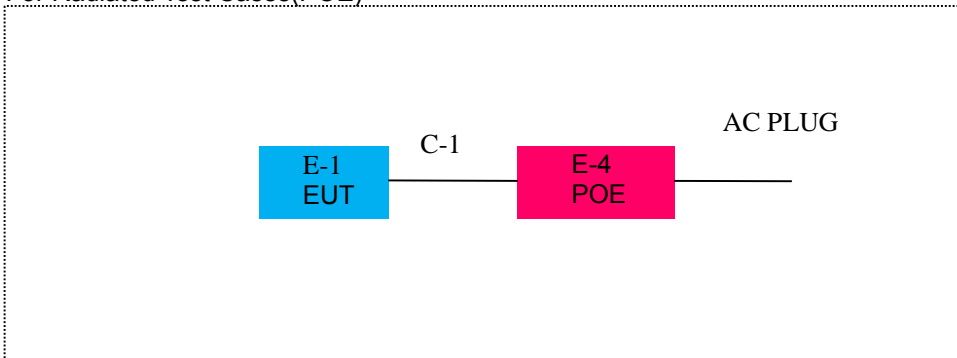

## 6.2 SUPPORT EQUIPMENT

The EUT has been tested as an independent unit together with other necessary accessories or support units. The following support units or accessories were used to form a representative test configuration during the tests.

Item	Equipment	Mfr/Brand	Model/Type No.	FCC ID	Note
E-1	DIGITAL ADVERTISEMENT SCREEN	N/A	ICI101	2AEZV-ICI101T	EUT
E-2	Adapter	N/A	P24090250 US	N/A	Peripherals
E-3	Earphone	N/A	2688	N/A	Peripherals
E-4	POE	N/A	PSE5416E	N/A	

Item	Cable Type	Shielded Type	Ferrite Core	Length
C-1	USB Cable	NO	NO	1.2m
C-2	Earphone Cable	NO	NO	0.8m
C-3	RJ45 Cable	NO	NO	0.8m

### Notes:

- (1) The support equipment was authorized by Declaration of Confirmation.
- (2) For detachable type I/O cable should be specified the length in cm in 『Length』 column.
- (3) “YES” is means “shielded” “with core”; “NO” is means “unshielded” “without core”.

### 6.3 EQUIPMENTS LIST FOR ALL TEST ITEMS

#### Radiation Test equipment

Item	Kind of Equipment	Manufacturer	Type No.	Serial No.	Last calibration	Calibrated until	Calibration period
1	Spectrum Analyzer	Agilent	E4407B	MY45108040	2017.06.06	2018.06.05	1 year
2	Spectrum Analyzer	Agilent	N9020A	MY49100060	2016.11.10	2017.11.09	1 year
3	EMI Test Receiver	Agilent	N9038A	MY53227146	2017.06.06	2018.06.05	1 year
4	Test Receiver	R&S	ESPI	101318	2017.06.06	2018.06.05	1 year
5	Bilog Antenna	TESEQ	CBL6111D	31216	2017.04.09	2018.04.08	1 year
6	50Ω Coaxial Switch	Anritsu	MP59B	6200983705	2017.06.06	2018.06.05	1 year
7	Horn Antenna	EM	EM-AH-10180	2011071402	2017.04.09	2018.04.08	1 year
8	Horn Ant	Schwarzbeck	BBHA 9170	9170-181	2017.07.06	2018.07.05	1 year
9	Amplifier	EMC	EMC051835SE	980246	2017.08.09	2018.08.08	1 year
10	Amplifier	MITEQ	TTA1840-35-HG	177156	2017.06.06	2018.06.05	1 year
11	Loop Antenna	ARA	PLA-1030/B	1029	2017.06.06	2018.06.05	1 year
12	Power Meter	DARE	RPR3006W	15I00041SN084	2017.08.09	2018.08.08	1 year
13	Test Cable (9KHz-30MHz)	N/A	R-01	N/A	2017.04.21	2020.04.20	3 year
14	Test Cable (30MHz-1GHz)	N/A	R-02	N/A	2017.04.21	2020.04.20	3 year
15	High Test Cable(1G-40G Hz)	N/A	R-03	N/A	2017.04.21	2020.04.20	3 year
16	High Test Cable(1G-40G Hz)	N/A	R-04	N/A	2017.04.21	2020.04.20	3 year
17	temporary antenna connector (Note)	NTS	R001	N/A	N/A	N/A	N/A

Note:

We will use the temporary antenna connector (soldered on the PCB board) When conducted test  
 And this temporary antenna connector is listed within the instrument list

## Conduction Test equipment

Item	Kind of Equipment	Manufacturer	Type No.	Serial No.	Last calibration	Calibrated until	Calibration period
1	Test Receiver	R&S	ESCI	101160	2017.06.06	2018.06.05	1 year
2	LISN	R&S	ENV216	101313	2017.04.19	2018.04.18	1 year
3	LISN	SCHWARZBECK	NNLK 8129	8129245	2017.06.06	2018.06.05	1 year
4	50Ω Coaxial Switch	ANRITSU CORP	MP59B	6200983704	2017.06.06	2018.06.05	1 year
5	Test Cable (9KHz-30MHz)	N/A	C01	N/A	2017.04.21	2020.04.20	3 year
6	Test Cable (9KHz-30MHz)	N/A	C02	N/A	2017.04.21	2020.04.20	3 year
7	Test Cable (9KHz-30MHz)	N/A	C03	N/A	2017.04.21	2020.04.20	3 year

1	Filter	TRILTHIC	2400MHz	29	2017.04.19	2018.04.18	1 year
---	--------	----------	---------	----	------------	------------	--------

Note: Each piece of equipment is scheduled for calibration once a year.

## 7 TEST REQUIREMENTS

### 7.1 CONDUCTED EMISSIONS TEST

#### 7.1.1 Applicable Standard

According to FCC Part 15.207(a) and KDB 174176 D01 Line Conducted FAQ v01r01

#### 7.1.2 Conformance Limit

Frequency(MHz)	Conducted Emission Limit	
	Quasi-peak	Average
0.15-0.5	66-56*	56-46*
0.5-5.0	56	46
5.0-30.0	60	50

Note: 1. \*Decreases with the logarithm of the frequency  
 2. The lower limit shall apply at the transition frequencies  
 3. The limit decreases in line with the logarithm of the frequency in the range of 0.15 to 0.50MHz.

#### 7.1.3 Measuring Instruments

The Measuring equipment is listed in the section 6.3 of this test report.

#### 7.1.4 Test Configuration

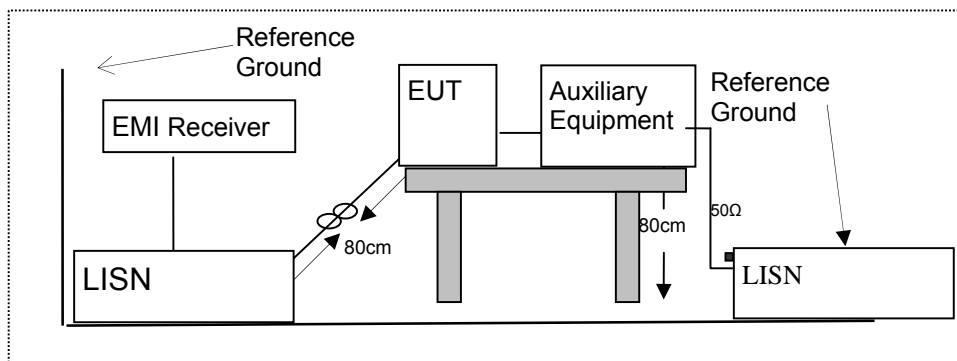

#### 7.1.5 Test Procedure

According to the requirements in Section 13.1.4.1 of ANSI C63.10-2013 Conducted emissions the EUT measured in the frequency range between 0.15 MHz and 30 MHz using CISPR Quasi-Peak and average detector mode.

1. The EUT was placed 0.4 meter from the conducting wall of the shielding room.
2. The EUT was placed on a table which is 0.8m above ground plane.
3. Connect EUT to the power mains through a line impedance stabilization network (LISN). All other support equipments powered from additional LISN(s). The LISN provide 50 Ohm/ 50uH of coupling impedance for the measuring instrument.
4. Interconnecting cables that hang closer than 40 cm to the ground plane shall be folded back and forth in the center forming a bundle 30 to 40cm long.
5. I/O cables that are not connected to a peripheral shall be bundled in the center. The end of the cable may be terminated, if required, using the correct terminating impedance. The overall length shall not exceed 1 m.
6. LISN at least 80 cm from nearest part of EUT chassis.
7. The frequency range from 150KHz to 30MHz was searched.
8. Set the test-receiver system to Peak Detect Function and specified bandwidth(IF bandwidth=9KHz) with Maximum Hold Mode
9. For the actual test configuration, please refer to the related Item –EUT Test Photos.

**7.1.6 Test Results**

EUT:	DIGITAL ADVERTISEMENT SCREEN	Model Name :	ICI101
Temperature:	26 °C	Relative Humidity:	54%
Pressure:	1010hPa	Phase :	L
Test Voltage :	DC 12V from Adapter AC 120V/60Hz	Test Mode:	Mode 1

Frequency (MHz)	Reading Level (dB $\mu$ V)	Correct Factor (dB)	Measure-ment (dB $\mu$ V)	Limits (dB $\mu$ V)	Margin (dB)	Remark
0.2459	31.5	9.7	41.2	61.89	-20.69	QP
0.2459	14.81	9.7	24.51	51.89	-27.38	AVG
0.4138	28.99	9.71	38.7	57.57	-18.87	QP
0.4138	10.63	9.71	20.34	47.57	-27.23	AVG
0.6219	20.39	9.71	30.1	56.00	-25.90	QP
0.6219	8.53	9.71	18.24	46.00	-27.76	AVG
1.9455	16.46	9.74	26.2	56.00	-29.80	QP
1.9455	5.2	9.74	14.94	46.00	-31.06	AVG
3.87	23.64	9.96	33.6	56.00	-22.40	QP
3.87	8.68	9.96	18.64	46.00	-27.36	AVG
10.3779	17.8	9.92	27.72	60.00	-32.28	QP
10.3779	6.82	9.92	16.74	50.00	-33.26	AVG

Remark:

1. All readings are Quasi-Peak and Average values.
2. Factor = Insertion Loss + Cable Loss.

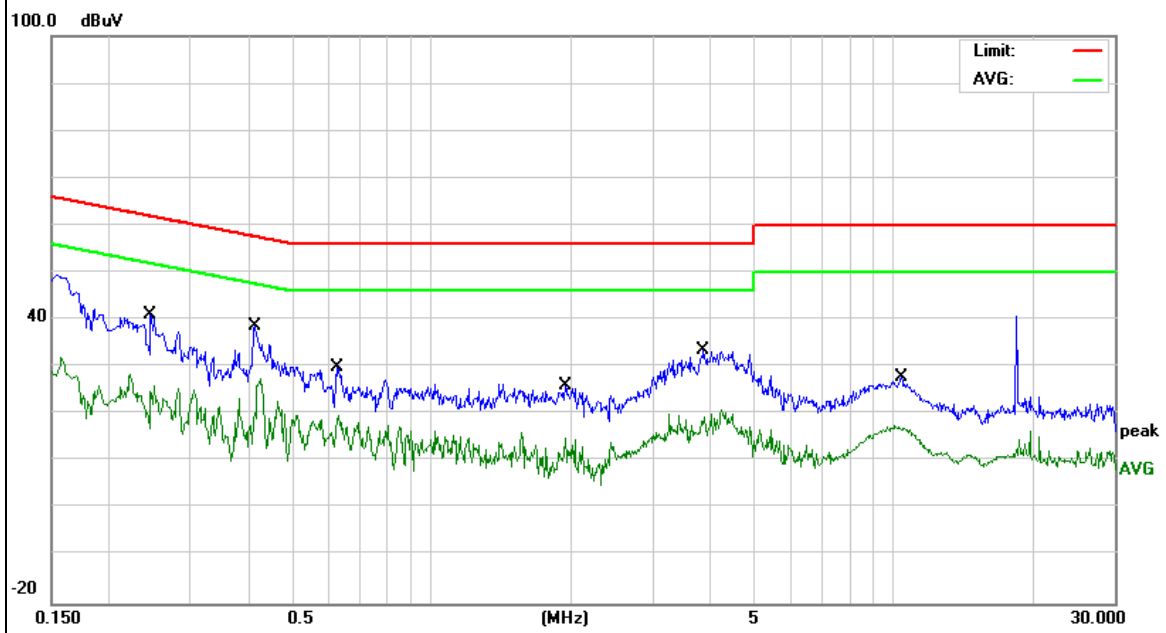



EUT:	DIGITAL ADVERTISEMENT SCREEN	Model Name :	IC1101
Temperature:	26 °C	Relative Humidity:	54%
Pressure:	1010hPa	Phase :	N
Test Voltage :	DC 12V from Adapter AC 120V/60Hz	Test Mode:	Mode 1

Frequency (MHz)	Reading Level (dBµV)	Correct Factor (dB)	Measure-ment (dBµV)	Limits (dBµV)	Margin (dB)	Remark
0.1985	31.3	9.8	41.1	63.67	-22.57	QP
0.1985	13.43	9.8	23.23	53.67	-30.44	AVG
0.2857	26.6	9.8	36.4	60.65	-24.25	QP
0.2857	10.4	9.8	20.2	50.65	-30.45	AVG
0.5181	21.09	9.81	30.9	56.00	-25.10	QP
0.5181	9.5	9.81	19.31	46.00	-26.69	AVG
0.8457	16.39	9.81	26.2	56.00	-29.80	QP
0.8457	2.02	9.81	11.83	46.00	-34.17	AVG
3.1099	21.65	9.85	31.5	56.00	-24.50	QP
3.1099	9.46	9.85	19.31	46.00	-26.69	AVG
4.6497	21.73	9.87	31.6	56.00	-24.40	QP
4.6497	4.32	9.87	14.19	46.00	-31.81	AVG

Remark:

1. All readings are Quasi-Peak and Average values.
2. Factor = Insertion Loss + Cable Loss.

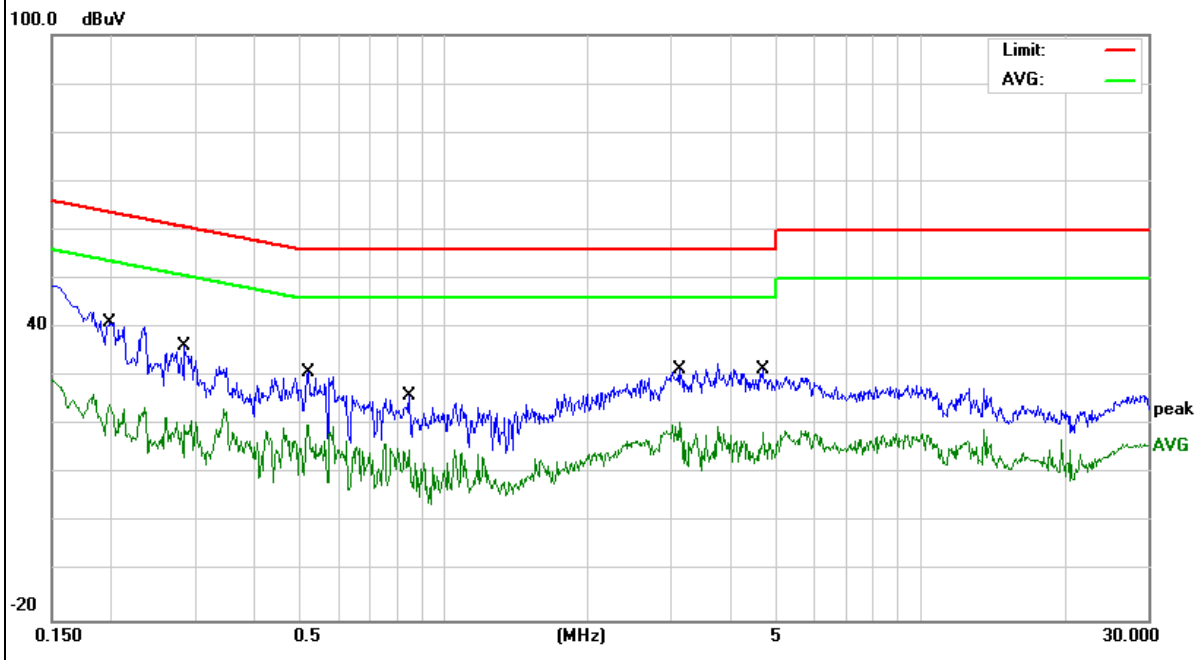

EUT:	DIGITAL ADVERTISEMENT SCREEN	Model Name :	ICI101
Temperature:	26 °C	Relative Humidity:	54%
Pressure:	1010hPa	Phase :	L
Test Voltage :	DC 12V from Adapter AC 240V/60Hz	Test Mode:	Mode 1

Frequency (MHz)	Reading Level (dBμV)	Correct Factor (dB)	Measure-ment (dBμV)	Limits (dBμV)	Margin (dB)	Remark
0.2083	35.4	9.7	45.1	63.27	-18.17	QP
0.2083	20.43	9.7	30.13	53.27	-23.14	AVG
0.4939	30.81	9.71	40.52	56.10	-15.58	QP
0.4939	12.96	9.71	22.67	46.10	-23.43	AVG
1.2379	18.89	9.8	28.69	56.00	-27.31	QP
1.2379	8.23	9.8	18.03	46.00	-27.97	AVG
1.9455	18.62	9.74	28.36	56.00	-27.64	QP
1.9455	2.8	9.74	12.54	46.00	-33.46	AVG
3.274	20.08	9.95	30.03	56.00	-25.97	QP
3.274	5.32	9.95	15.27	46.00	-30.73	AVG
9.0457	20.71	9.89	30.6	60.00	-29.40	QP
9.0457	10.34	9.89	20.23	50.00	-29.77	AVG

Remark:

1. All readings are Quasi-Peak and Average values.
2. Factor = Insertion Loss + Cable Loss.

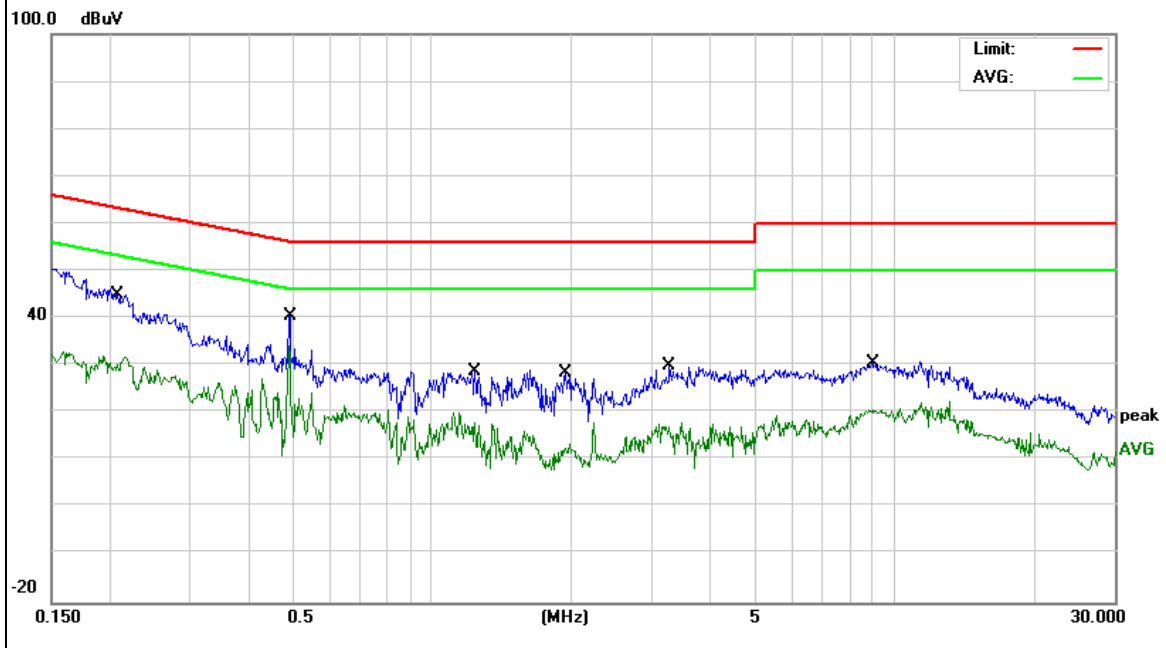



EUT:	DIGITAL ADVERTISEMENT SCREEN	Model Name :	IC1101
Temperature:	26 °C	Relative Humidity:	54%
Pressure:	1010hPa	Phase :	N
Test Voltage :	DC 12V from Adapter AC 240V/60Hz	Test Mode:	Mode 1

Frequency (MHz)	Reading Level (dB $\mu$ V)	Correct Factor (dB)	Measure-ment (dB $\mu$ V)	Limits (dB $\mu$ V)	Margin (dB)	Remark
0.226	31.6	9.8	41.4	62.59	-21.19	QP
0.226	14.25	9.8	24.05	52.59	-28.54	AVG
0.446	20.99	9.81	30.8	56.95	-26.15	QP
0.446	10.36	9.81	20.17	46.95	-26.78	AVG
1.07	20.88	9.82	30.7	56.00	-25.30	QP
1.07	4.07	9.82	13.89	46.00	-32.11	AVG
2.6179	23.16	9.84	33	56.00	-23.00	QP
2.6179	9.86	9.84	19.7	46.00	-26.30	AVG
3.278	25.75	9.85	35.6	56.00	-20.40	QP
3.278	9.33	9.85	19.18	46.00	-26.82	AVG
7.2819	25.22	9.98	35.2	60.00	-24.80	QP
7.2819	12.99	9.98	22.97	50.00	-27.03	AVG

Remark:

1. All readings are Quasi-Peak and Average values.
2. Factor = Insertion Loss + Cable Loss.

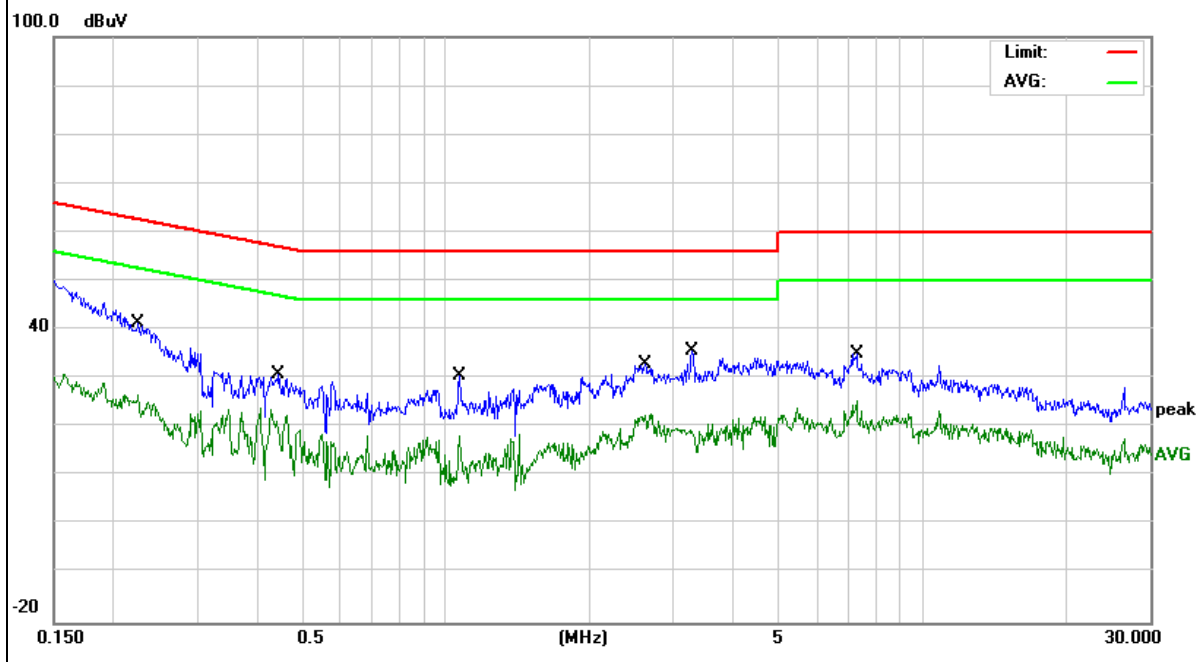

EUT:	DIGITAL ADVERTISEMENT SCREEN	Model Name :	IC1101
Temperature:	26 °C	Relative Humidity:	54%
Pressure:	1010hPa	Phase :	L
Test Voltage :	DC 48V from POE AC 120V/60Hz	Test Mode:	Mode 1

Frequency (MHz)	Reading Level (dBμV)	Correct Factor (dB)	Measure-ment (dBμV)	Limits (dBμV)	Margin (dB)	Remark
0.198	44.64	9.82	54.46	63.69	-9.23	QP
0.198	27.13	9.82	36.95	53.69	-16.74	AVG
0.2467	40.38	9.82	50.2	61.86	-11.66	QP
0.2467	16.41	9.82	26.23	51.86	-25.63	AVG
0.678	35.16	9.83	44.99	56.00	-11.01	QP
0.678	16.97	9.83	26.8	46.00	-19.20	AVG
1.542	29.74	9.89	39.63	56.00	-16.37	QP
1.542	16.9	9.89	26.79	46.00	-19.21	AVG
2.406	30.8	9.92	40.72	56.00	-15.28	QP
2.406	15.35	9.92	25.27	46.00	-20.73	AVG
5.0979	29.43	10.06	39.49	60.00	-20.51	QP
5.0979	15.04	10.06	25.1	50.00	-24.90	AVG

Remark:

- All readings are Quasi-Peak and Average values.
- Factor = Insertion Loss + Cable Loss.

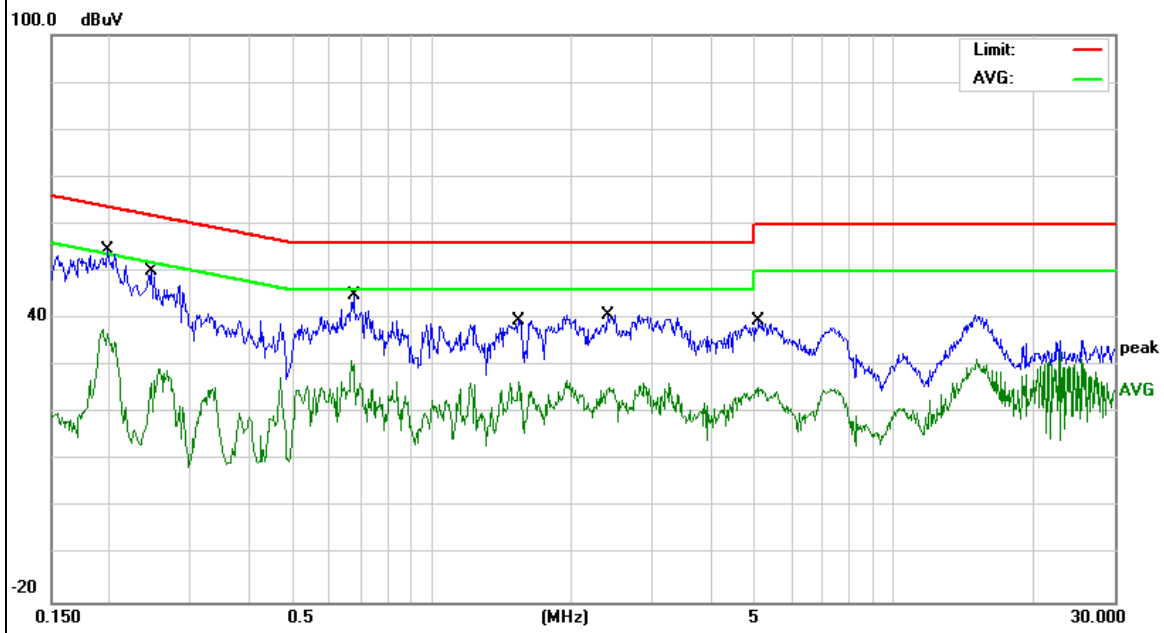

EUT:	DIGITAL ADVERTISEMENT SCREEN	Model Name :	ICI101
Temperature:	26 °C	Relative Humidity:	54%
Pressure:	1010hPa	Phase :	N
Test Voltage :	DC 48V from POE AC 120V/60Hz	Test Mode:	Mode 1

Frequency (MHz)	Reading Level (dB $\mu$ V)	Correct Factor (dB)	Measure-ment (dB $\mu$ V)	Limits (dB $\mu$ V)	Margin (dB)	Remark
0.1955	44.68	9.92	54.6	63.8	-9.2	QP
0.1955	27.76	9.92	37.68	53.80	-16.12	AVG
0.662	37.07	9.93	47	56	-9.00	QP
0.662	21.68	9.93	31.61	46.00	-14.39	AVG
2.446	31.09	9.94	41.03	56.00	-14.97	QP
2.446	14.43	9.94	24.37	46.00	-21.63	AVG
3.25	31.33	9.95	41.28	56.00	-14.72	QP
3.25	12.1	9.95	22.05	46.00	-23.95	AVG
5.1657	29.5	9.97	39.47	60.00	-20.53	QP
5.1657	14.55	9.97	24.52	50.00	-25.48	AVG
14.5617	28.99	10.24	39.23	60.00	-20.77	QP
14.5617	17.39	10.24	27.63	50.00	-22.37	AVG

Remark:

1. All readings are Quasi-Peak and Average values.
2. Factor = Insertion Loss + Cable Loss.

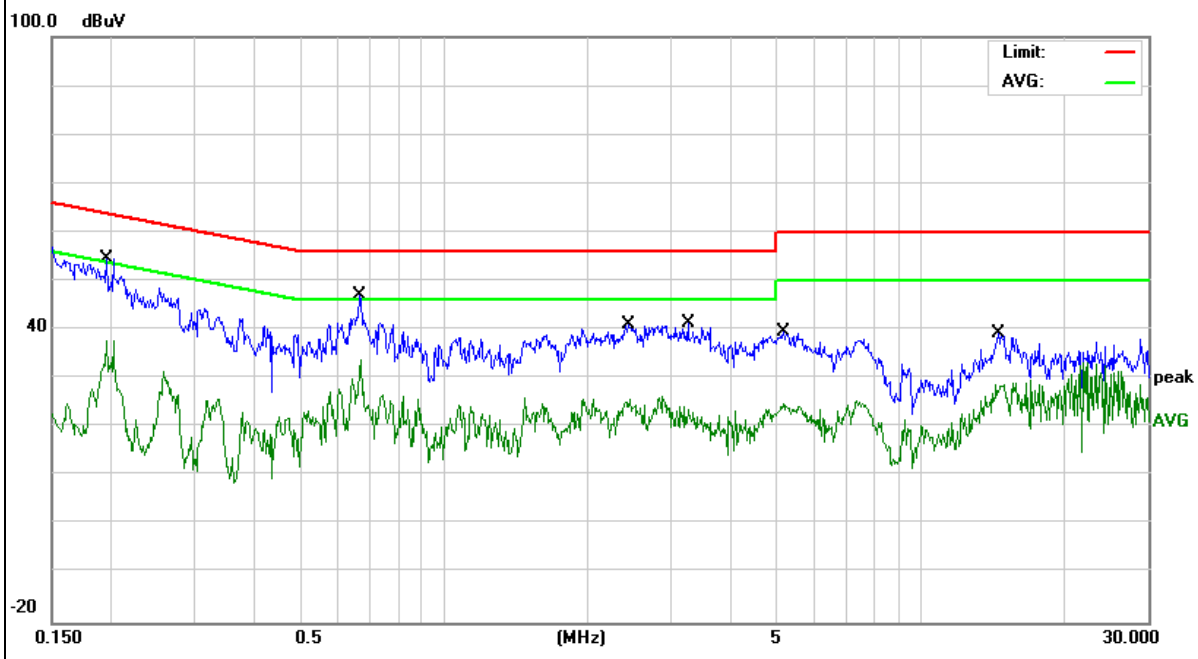

EUT:	DIGITAL ADVERTISEMENT SCREEN	Model Name :	IC1101
Temperature:	26 °C	Relative Humidity:	54%
Pressure:	1010hPa	Phase :	L
Test Voltage :	DC 48V from POE AC 240V/60Hz	Test Mode:	Mode 1

Frequency (MHz)	Reading Level (dB $\mu$ V)	Correct Factor (dB)	Measure-ment (dB $\mu$ V)	Limits (dB $\mu$ V)	Margin (dB)	Remark
0.198	40.58	9.82	50.4	63.69	-13.29	QP
0.198	25.38	9.82	35.2	53.69	-18.49	AVG
0.6895	38.4	9.83	48.23	56	-7.77	QP
0.6895	18.52	9.83	28.35	46.00	-17.65	AVG
1.2459	35.99	9.91	45.9	56.00	-10.10	QP
1.2459	15.38	9.91	25.29	46.00	-20.71	AVG
1.9818	34.51	9.84	44.35	56.00	-11.65	QP
1.9818	17.32	9.84	27.16	46.00	-18.84	AVG
3.442	35.85	10.05	45.9	56.00	-10.10	QP
3.442	19.15	10.05	29.2	46.00	-16.80	AVG
15.1135	34.62	10.22	44.84	60.00	-15.16	QP
15.1135	23.04	10.22	33.26	50.00	-16.74	AVG

Remark:

- All readings are Quasi-Peak and Average values.
- Factor = Insertion Loss + Cable Loss.

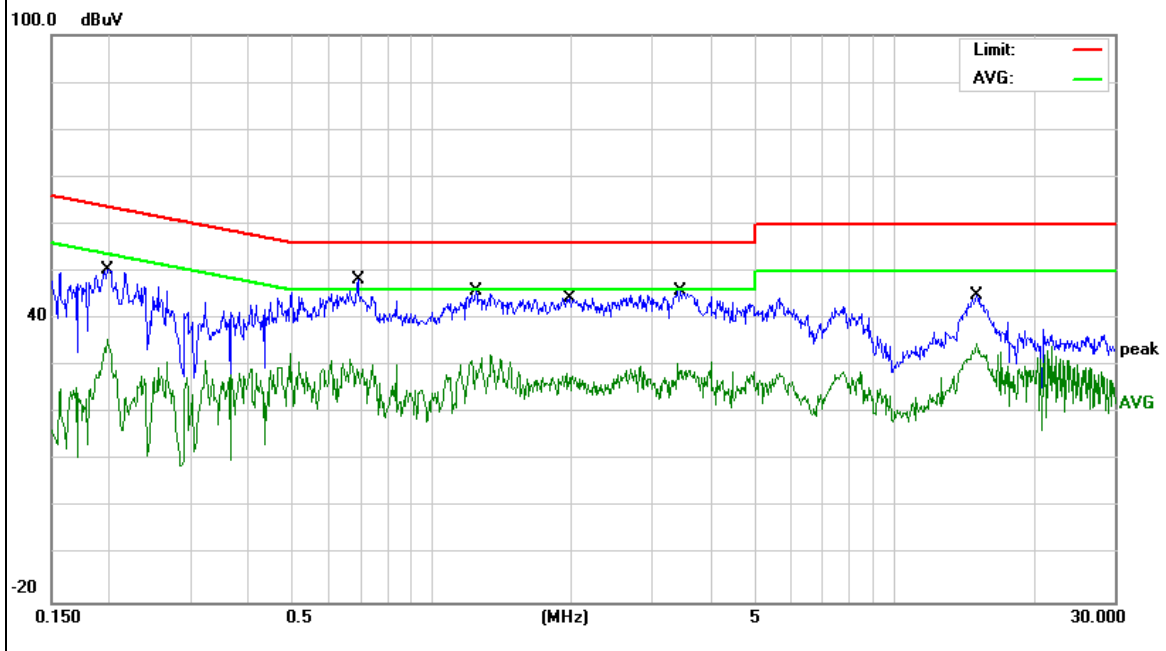

EUT:	DIGITAL ADVERTISEMENT SCREEN	Model Name :	IC1101
Temperature:	26 °C	Relative Humidity:	54%
Pressure:	1010hPa	Phase :	N
Test Voltage :	DC 48V from POE AC 240V/60Hz	Test Mode:	Mode 1

Frequency (MHz)	Reading Level (dB $\mu$ V)	Correct Factor (dB)	Measure-ment (dB $\mu$ V)	Limits (dB $\mu$ V)	Margin (dB)	Remark
0.202	44.06	9.92	53.98	63.52	-9.54	QP
0.202	26.74	9.92	36.66	53.52	-16.86	AVG
0.27	38.9	9.92	48.82	61.12	-12.30	QP
0.27	22.04	9.92	31.96	51.12	-19.16	AVG
0.6139	34.22	9.93	44.15	56.00	-11.85	QP
0.6139	14.72	9.93	24.65	46.00	-21.35	AVG
0.882	35.57	9.93	45.5	56.00	-10.50	QP
0.882	19.1	9.93	29.03	46.00	-16.97	AVG
1.33	35.87	9.93	45.8	56.00	-10.20	QP
1.33	20.71	9.93	30.64	46.00	-15.36	AVG
3.0099	37.15	9.95	47.1	56	-8.9	QP
3.0099	20.69	9.95	30.64	46.00	-15.36	AVG

Remark:

1. All readings are Quasi-Peak and Average values.
2. Factor = Insertion Loss + Cable Loss.

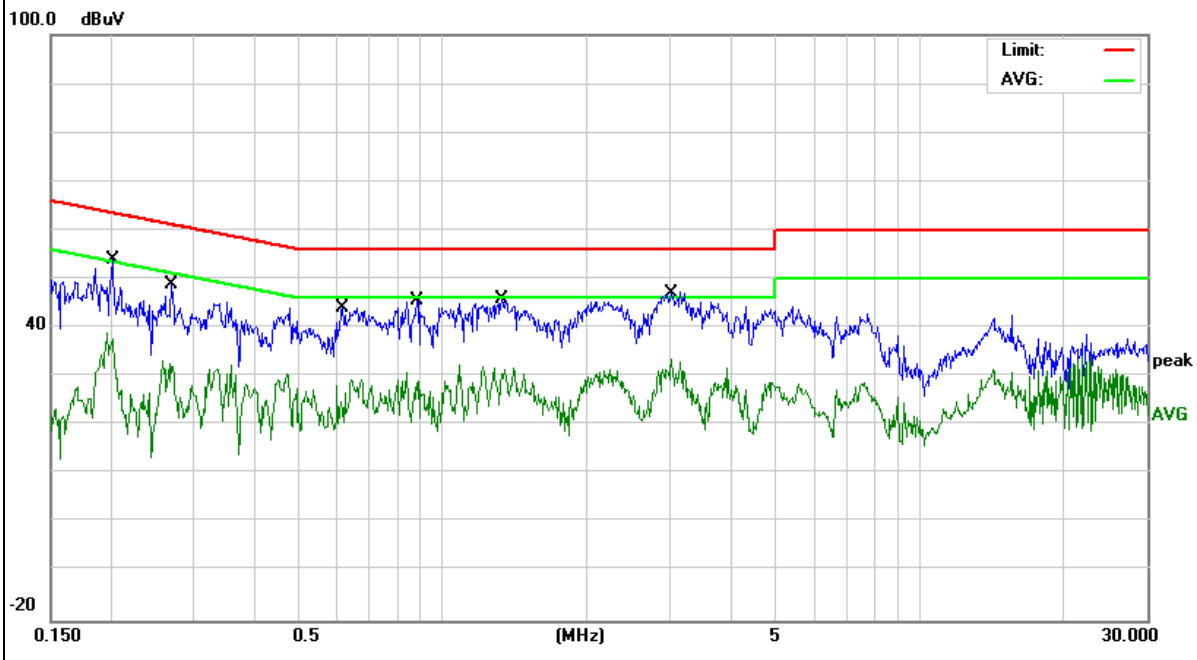

## 7.2 RADIATED SPURIOUS EMISSION

### 7.2.1 Applicable Standard

According to FCC Part 15.247(d) and 15.209 and ANSI C63.10-2013

### 7.2.2 Conformance Limit

According to FCC Part 15.247(d): radiated emissions which fall in the restricted bands, as defined in §15.205(a), must also comply with the radiated emission limits specified in §15.209(a) (see §15.205(c)).  
According to FCC Part 15.205, Restricted bands

MHz	MHz	MHz	GHz
0.090-0.110	16.42-16.423	399.9-410	4.5-5.15
10.495-0.505	16.69475-16.69525	608-614	5.35-5.46
2.1735-2.1905	16.80425-16.80475	960-1240	7.25-7.75
4.125-4.128	25.5-25.67	1300-1427	8.025-8.5
4.17725-4.17775	37.5-38.25	1435-1626.5	9.0-9.2
4.20725-4.20775	73-74.6	1645.5-1646.5	9.3-9.5
6.215-6.218	74.8-75.2	1660-1710	10.6-12.7
6.26775-6.26825	123-138	2200-2300	14.47-14.5
8.291-8.294	149.9-150.05	2310-2390	15.35-16.2
8.362-8.366	156.52475-156.52525	2483.5-2500	17.7-21.4
8.37625-8.38675	156.7-156.9	2690-2900	22.01-23.12
8.41425-8.41475	162.0125-167.17	3260-3267	23.6-24.0
12.29-12.293	167.72-173.2	3332-3339	31.2-31.8
12.51975-12.52025	240-285	3345.8-3358	36.43-36.5
12.57675-12.57725	322-335.4	3600-4400	(2)
13.36-13.41			

20dBc in any 100 kHz bandwidth outside the operating frequency band. In case the emission fall within the restricted band specified on 15.205(a), then the 15.209(a) limit in the table below has to be followed.

Restricted Frequency(MHz)	Field Strength ( $\mu\text{V/m}$ )	Field Strength ( $\text{dB}\mu\text{V/m}$ )	Measurement Distance
0.009~0.490	2400/F(KHz)	20 log (uV/m)	300
0.490~1.705	2400/F(KHz)	20 log (uV/m)	30
1.705~30.0	30	29.5	30
30-88	100	40	3
88-216	150	43.5	3
216-960	200	46	3
Above 960	500	54	3

Limits of Radiated Emission Measurement(Above 1000MHz)

Frequency(MHz)	Class B (dBuV/m) (at 3M)	
	PEAK	AVERAGE
Above 1000	74	54

Remark :1. Emission level in  $\text{dBuV/m}=20 \log (\text{uV/m})$   
 2. Measurement was performed at an antenna to the closed point of EUT distance of meters.  
 3. Distance extrapolation factor  $=40 \log (\text{Specific distance}/ \text{test distance})(\text{dB})$ ;  
 Limit line=Specific limits(dBuV) + distance extrapolation factor.

### 7.2.3 Measuring Instruments

The Measuring equipment is listed in the section 6.3 of this test report.

### 7.2.4 Test Configuration

(a) For radiated emissions below 30MHz

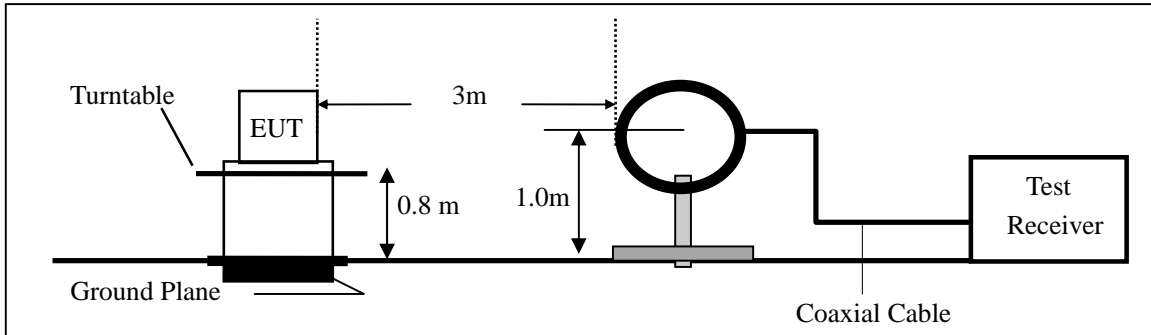

(b) For radiated emissions from 30MHz to 1000MHz

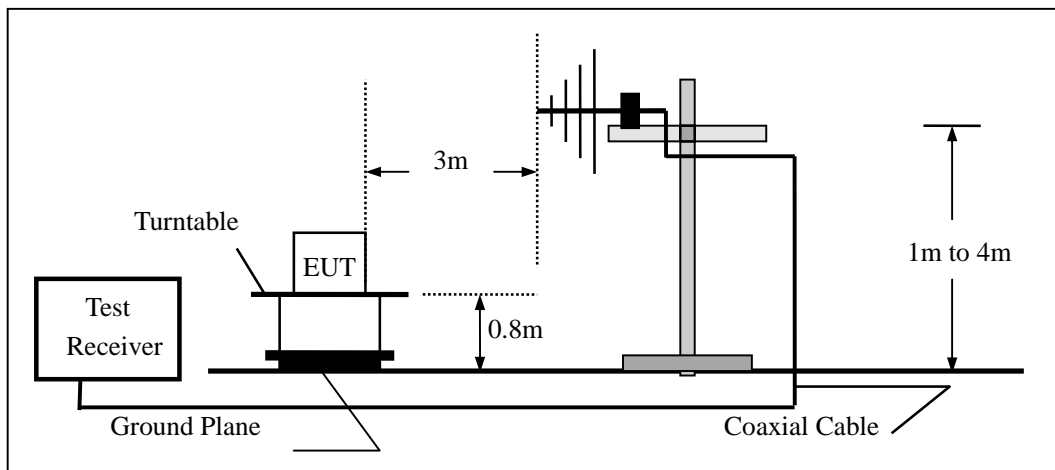

(c) For radiated emissions above 1000MHz

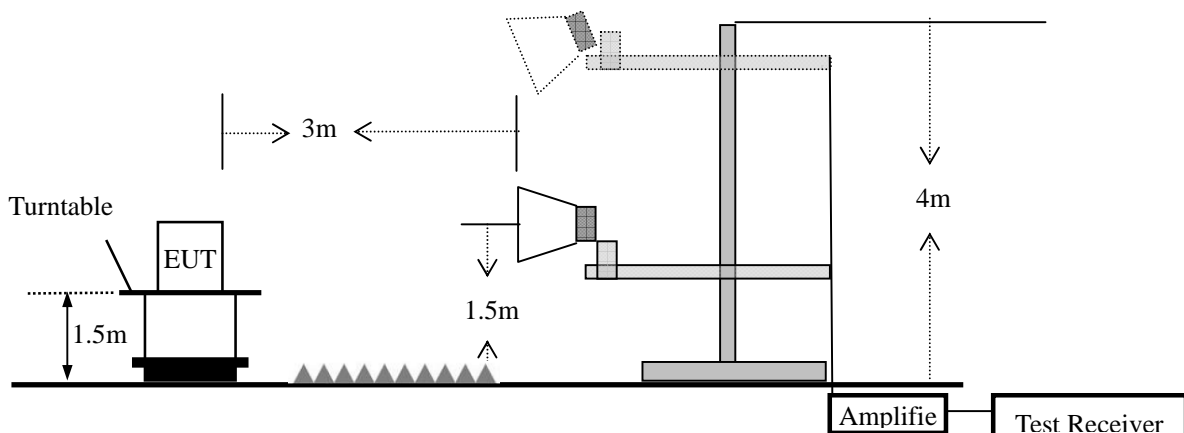

### 7.2.5 Test Procedure

The test site semi-anechoic chamber has met the requirement of NSA tolerance 4 dB according to the standards: ANSI C63.10-2013. The test distance is 3m. The setup is according to the requirements in Section 13.1.4.1 of ANSI C63.10-2013 and CAN/CSA-CEI/IEC CISPR 22.

This test is required for any spurious emission that falls in a Restricted Band, as defined in Section 15.205. It must be performed with the highest gain of each type of antenna proposed for use with the EUT.

Use the following spectrum analyzer settings:

Spectrum Parameter	Setting
Attenuation	Auto
Start Frequency	1000 MHz
Stop Frequency	10th carrier harmonic
RB / VB (emission in restricted band)	1 MHz / 1 MHz for Peak, 1 MHz / 10Hz for Average

Receiver Parameter	Setting
Attenuation	Auto
Start ~ Stop Frequency	9kHz~150kHz / RB 200Hz for QP
Start ~ Stop Frequency	150kHz~30MHz / RB 9kHz for QP
Start ~ Stop Frequency	30MHz~1000MHz / RB 120kHz for QP

- a. The measuring distance of at 3 m shall be used for measurements at frequency up to 1GHz. For frequencies above 1GHz, any suitable measuring distance may be used.
- b. The EUT was placed on the top of a rotating table 0.8 m for below 1GHz and 1.5m for above 1GHz the ground at a 3 meter. The table was rotated 360 degrees to determine the position of the highest radiation.
- c. The height of the equipment or of the substitution antenna shall be 0.8 m for below 1GHz and 1.5m for above 1GHz; the height of the test antenna shall vary between 1 m to 4 m. Both horizontal and vertical polarizations of the antenna are set to make the measurement.
- d. For the radiated emission test above 1GHz:  
Place the measurement antenna away from each area of the EUT determined to be a source of emissions at the specified measurement distance, while keeping the measurement antenna aimed at the source of emissions at each frequency of significant emissions, with polarization oriented for maximum response. The measurement antenna may have to be higher or lower than the EUT, depending on the radiation pattern of the emission and staying aimed at the emission source for receiving the maximum signal. The final measurement antenna elevation shall be that which maximizes the emissions. The measurement antenna elevation for maximum emissions shall be restricted to a range of heights of from 1 m to 4 m above the ground or reference ground plane.
- e. The initial step in collecting conducted emission data is a spectrum analyzer peak detector mode pre-scanning the measurement frequency range. Significant peaks are then marked and then Quasi Peak detector mode re-measured.
- f. If the Peak Mode measured value compliance with and lower than Quasi Peak Mode Limit, the EUT shall be deemed to meet QP Limits and then no additional QP Mode measurement performed.
- g. For the actual test configuration, please refer to the related Item –EUT Test Photos.

Note:

Both horizontal and vertical antenna polarities were tested and performed pretest to three orthogonal axis. The worst case emissions were reported



During the radiated emission test, the Spectrum Analyzer was set with the following configurations:

Frequency Band (MHz)	Function	Resolution bandwidth	Video Bandwidth
30 to 1000	QP	120 kHz	300 kHz
Above 1000	Peak	1 MHz	1 MHz
	Average	1 MHz	10 Hz

Note: for the frequency ranges below 30 MHz, a narrower RBW is used for these ranges but the measured value should add a RBW correction factor (RBWCF) where  $RBWCF [dB] = 10 \cdot \lg(100 [kHz] / \text{narrower RBW [kHz]})$ . , the narrower RBW is 1 kHz and RBWCF is 20 dB for the frequency 9 kHz to 150 kHz, and the narrower RBW is 10 kHz and RBWCF is 10 dB for the frequency 150 kHz to 30 MHz.

### 7.2.6 Test Results

#### ■ Spurious Emission below 30MHz (9KHz to 30MHz)

EUT:	DIGITAL ADVERTISEMENT SCREEN	Model No.:	ICI101
Temperature:	20 °C	Relative Humidity:	48%
Test Mode:	Mode2/Mode3/Mode4	Test By:	Susan Su

Freq. (MHz)	Ant.Pol. H/V	Emission Level(dBuV/m)		Limit 3m(dBuV/m)		Over(dB)	
		PK	AV	PK	AV	PK	AV
--	--	--	--	--	--	--	--

Note: the amplitude of spurious emission that is attenuated by more than 20dB below the permissible limit has no need to be reported.

Distance extrapolation factor =  $20 \log(\text{Specific distance} / \text{test distance})$  ( dB);

Limit line = Specific limits(dBuV) + distance extrapolation factor

- Spurious Emission below 1GHz (30MHz to 1GHz)  
All the modulation modes have been tested, and the worst result was report as below:

EUT:	DIGITAL ADVERTISEMENT SCREEN	Model Name :	ICI101
Temperature:	20 °C	Relative Humidity:	48%
Pressure:	1010hPa	Test Mode:	Mode 1
Test Voltage :	DC 12V from Adapter AC 120V/60Hz		

Polar (H/V)	Frequency	Meter Reading	Factor	Emission Level	Limits	Margin	Remark
	(MHz)	(dBuV)	(dB)	(dBuV/m)	(dBuV/m)	(dB)	
V	36.8952	12.95	18.02	30.97	40	-9.03	QP
V	45.0583	14.76	13.68	28.44	40	-11.56	QP
V	115.3204	16.91	10.09	27	43.5	-16.5	QP
V	178.7581	14.99	12.72	27.71	43.5	-15.79	QP
V	293.0842	11.46	14.38	25.84	46	-20.16	QP
V	472.1759	12.11	16.68	28.79	46	-17.21	QP

**Remark:**

Absolute Level= ReadingLevel+ Factor, Margin= Absolute Level - Limit

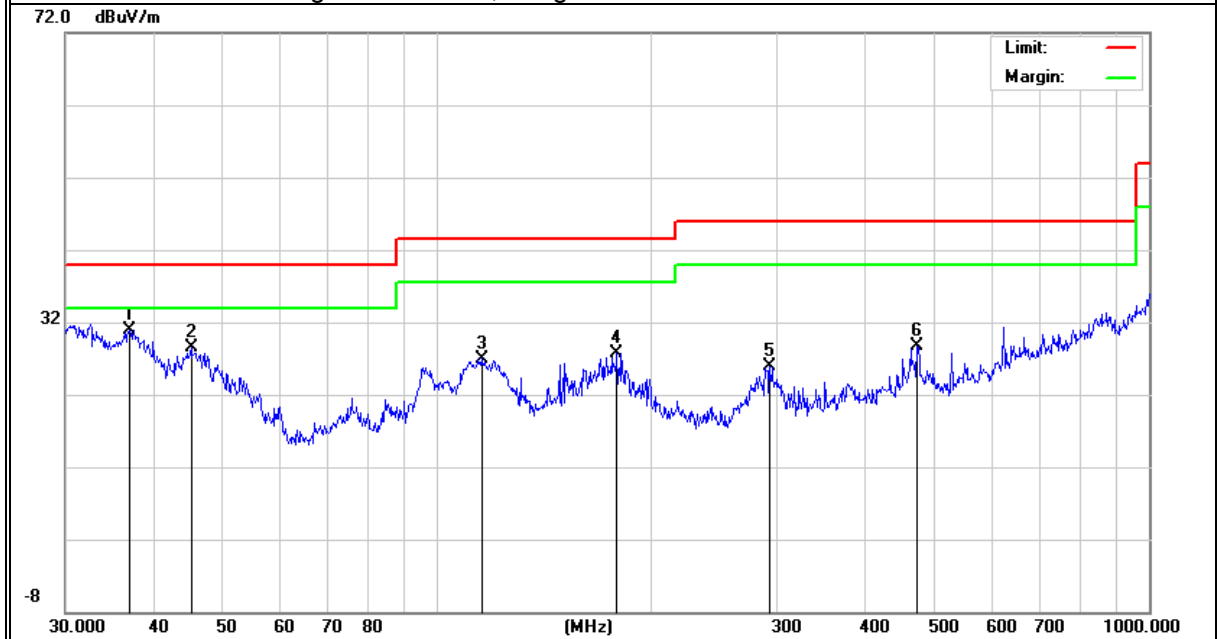

Polar (H/V)	Frequency	Meter Reading	Factor	Emission Level	Limits	Margin	Remark
	(MHz)	(dBuV)	(dB)	(dBuV/m)	(dBuV/m)	(dB)	
H	34.1561	5.37	19.3	24.67	40	-15.33	QP
H	43.0504	5.99	14.91	20.9	40	-19.1	QP
H	80.644	10.66	11.34	22	40	-18	QP
H	172.5988	14.89	12.64	27.53	43.5	-15.97	QP
H	275.1569	13.23	13.97	27.2	46	-18.8	QP
H	734.4913	11.56	22.34	33.9	46	-12.1	QP

**Remark:**

Absolute Level= ReadingLevel+ Factor, Margin= Absolute Level - Limit

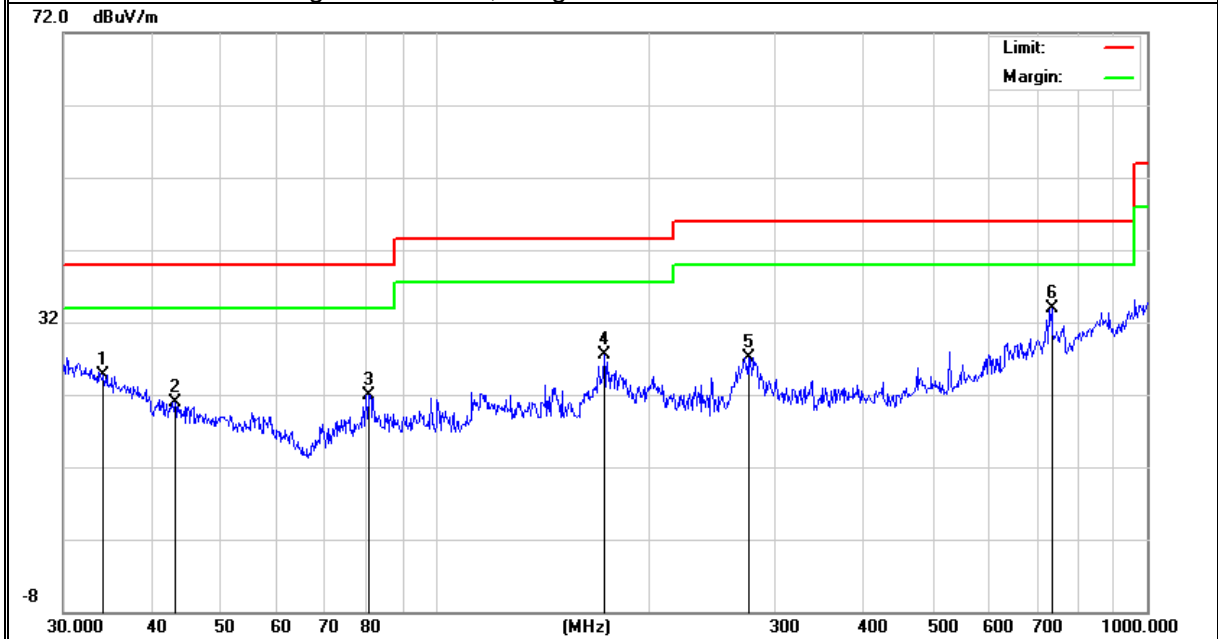



EUT:	DIGITAL ADVERTISEMENT SCREEN	Model Name :	ICI101
Temperature:	20 °C	Relative Humidity:	48%
Pressure:	1010hPa	Test Mode:	Mode 1
Test Voltage :	DC 48V from POE AC 120V/60Hz		

Polar (H/V)	Frequency	Meter Reading	Factor	Emission Level	Limits	Margin	Remark
	(MHz)	(dBuV)	(dB)	(dBuV/m)	(dBuV/m)	(dB)	
V	39.7146	19.17	16.44	35.61	40	-4.39	QP
V	91.8161	25.41	11.89	37.3	43.5	-6.2	QP
V	100.2286	27.37	10.27	37.64	43.5	-5.86	QP
V	133.1511	25.16	11.25	36.41	43.5	-7.09	QP
V	177.5089	23.99	12.69	36.68	43.5	-6.82	QP
V	305.68	13	13.9	26.9	46	-19.1	QP

**Remark:**

Absolute Level= ReadingLevel+ Factor, Margin= Absolute Level - Limit

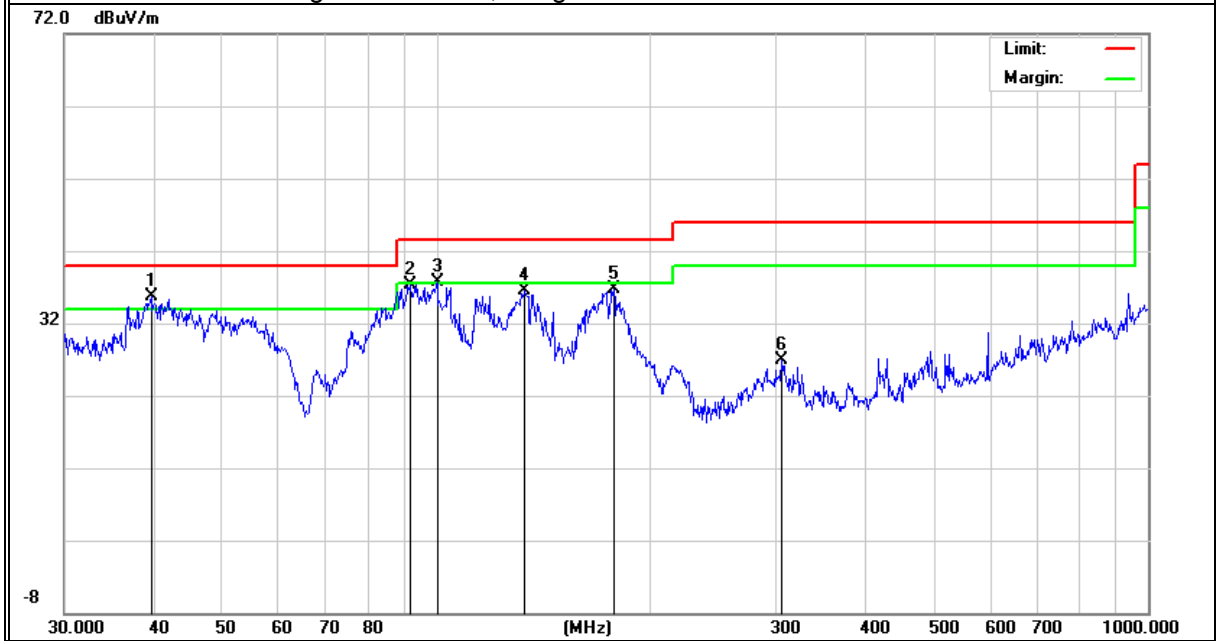

Polar (H/V)	Frequency	Meter Reading	Factor	Emission Level	Limits	Margin	Remark
	(MHz)	(dBuV)	(dB)	(dBuV/m)	(dBuV/m)	(dB)	
H	59.0251	18.82	11.58	30.4	40	-9.6	QP
H	91.4949	23.81	11.88	35.69	43.5	-7.81	QP
H	97.798	24.25	10.42	34.67	43.5	-8.83	QP
H	135.0319	19.49	11.7	31.19	43.5	-12.31	QP
H	177.5089	19.73	12.69	32.42	43.5	-11.08	QP
H	300.3672	11.76	14.67	26.43	46	-19.57	QP

**Remark:**

Absolute Level= ReadingLevel+ Factor, Margin= Absolute Level - Limit

