ICI101

Data Sheet

Processor	Intel® Atom™ Z3735G (Quad Core)
Memory	RAM 1 GB Flash 8 GB
Graphic card	Intel® HD Graphics
Panel	LCD 10,1" Resolution: 1280x800 px Brightness: 400 cd Service life: 15.000 horas
Operating system	Android 4.4
Ports	USB 2x2.0 Card reader Micro SD HDMI 1,4 A
Connectivity	Wifi 802.11 b/g/n (n20/n40) Bluetooth 4.0
Audio	Ethernet PoE 802.3 af Jack Audio
AC Adapter	Input: 100-240V, 50-60 Hz, 0.5A Max. Output: 12V, 1.5A
Use	Standard: 7W Maximum: 10W
Guarantee	2 years
Certifications	CE, FCC, RoSH

Commercial name of the device: ED1011. Certification code ICI101.
Inusual Comunicación Innovadora, S.L hereby declares that the device 10,1 Inch Digital Advertisement Device, modelo ICI101, meets the necessary requirements and other relevant provisions of Directive 1999/5/EC

QUICK GUIDE



Offers full communication at selling point

Advertisement Screen of 10,1 inches that use **POE connection**. Equipped with an Intel® Atom™ Quad Core processor, with Android 4.4 operating system and able to play videos, pictures and websites.

 **PoE** (Power over Ethernet):
No battery needed
Forget about problems involving
lithium batteries.



Technical Plans

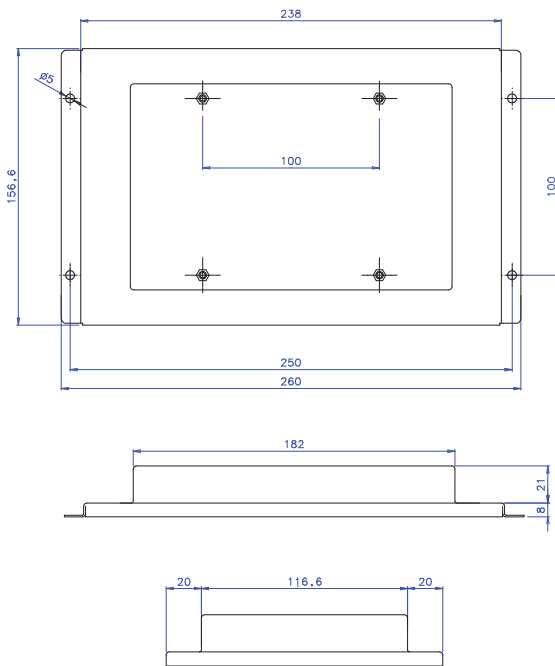

Operating Mode

- Using PoE connection (Power on Ethernet):

The device is powered via a power supply using the same Ethernet cable. This way, we remove the use of batteries and power sources connected to AC adapter.

It is important to check the RJ45 cable is conveniently connected to a switch that permits PoE connection; otherwise the device will not work.

- By Power Supply:

Optionally, a power supply can be used (not included) connected to a AC adapter. Thanks to this option, the RJ45 cable can be connected to a standard switch that will just offer a network connection for data transfer.

ports identification



RECYCLING

This product bears the selective sorting symbol for Waste electrical and electronic equipment (WEEE). This means that this product must be handled pursuant to European directive 2012/19/EU in order to be recycled or dismantled to minimize its impact on the environment. User has the choice to give his product to a competent recycling organization or to the retailer when he buys a new electrical or electronic equipment.

Interface action specification:

ETH: Ethernet network port supports 10/100Mbps

12V in: DC 12 input, compatible power input, mainly used for mass production

Reset: Reset switch

On-off: Switch on and off

USB: USB2.0 interface to connect USB device data communications

USB: USB2.0 interface to connect USB devices to data communications

HDMI: HDMI output interface, connect HDMI display device

Micro SD: Micro SD insert interface, SD card data transmission

SPK: Earphone insert interface, output audio

FCC Caution:

This device complies with part 15 of the FCC Rules. Operation is subject to the following two conditions: (1) this device may not cause harmful interference, and (2) this device must accept any

interference received, including interference that may cause undesired operation..

Any changes or modifications not expressly approved by the party responsible for compliance could void the user's authority to operate the equipment.

NOTE: This equipment has been tested and found to comply with the limits for a Class B digital

device, pursuant to Part 15 of the FCC Rules. These limits are designed to provide reasonable protection against harmful interference in a residential installation. This equipment generates, uses

and can radiate radio frequency energy and, if not installed and used in accordance with the instructions, may cause harmful interference to radio communications. However, there is no guarantee that interference will not occur in a particular installation.

If this equipment does cause harmful interference to radio or television reception, which can be

determined by turning the equipment off and on, the user is encouraged to try to correct the interference by one or more of the following measures:

- Reorient or relocate the receiving antenna.
- Increase the separation between the equipment and receiver.
- Connect the equipment into an outlet on a circuit different from that to which the receiver is connected.
- Consult the dealer or an experienced radio/TV technician for help.

To maintain compliance with FCC's RF Exposure guidelines, This equipment should be installed

and operated with minimum distance between 20cm the radiator your body: Use only the supplied

antenna.

FCC ID: 2AEZV-ICI101T