



TEST REPORT

Report Reference No...... : **TRE1801017103** R/C.....: 67477

FCC ID..... : **2AEY7-S8A003**

Applicant's name..... : **Bak USA Technologies Corp.**

Address..... : 425 Michigan Avenue,Buffalo,New York 14203,USA

Manufacturer..... : Bak USA Technologies Corp.

Address..... : 425 Michigan Avenue,Buffalo,New York 14203,USA

Test item description : **Tablet PC**

Trade Mark : -

Model/Type reference..... : LTE Barcode 1.0

Listed Model(s) : -

Standard : **FCC CFR Title 47 Part 15 Subpart C Section 15.247**

Date of receipt of test sample..... : Jan.22,2018

Date of testing..... : Jan.23,2018- Feb.06,2018

Date of issue..... : Feb.07,2018

Result..... : **PASS**

Compiled by
(Position+Printed name+Signature) : File administrators Candy Liu *Candy Liu*

Supervised by
(Position+Printed name+Signature) : Project Engineer : Edward Pan *Edward Pan*

Approved by
(Position+Printed name+Signature) : RF Manager Hans Hu *Hans Hu*

Testing Laboratory Name : **Shenzhen Huatongwei International Inspection Co., Ltd.**

Address..... : 1/F, Bldg 3, Hongfa Hi-tech Industrial Park, Genyu Road, Tianliao, Gongming, Shenzhen, China

Shenzhen Huatongwei International Inspection Co., Ltd. All rights reserved.

This publication may be reproduced in whole or in part for non-commercial purposes as long as the Shenzhen Huatongwei International Inspection Co., Ltd. is acknowledged as copyright owner and source of the material. Shenzhen Huatongwei International Inspection Co., Ltd. takes no responsibility for and will not assume liability for damages resulting from the reader's interpretation of the reproduced material due to its placement and context.

The test report merely correspond to the test sample.

Contents

1.	<u>TEST STANDARDS AND REPORT VERSION</u>	3
1.1.	Test Standards	3
1.2.	Report version	3
2.	<u>TEST DESCRIPTION</u>	4
3.	<u>SUMMARY</u>	5
3.1.	Client Information	5
3.2.	Product Description	5
3.3.	Operation state	6
3.4.	EUT configuration	6
3.5.	Modifications	6
4.	<u>TEST ENVIRONMENT</u>	7
4.1.	Address of the test laboratory	7
4.2.	Test Facility	7
4.3.	Environmental conditions	8
4.4.	Statement of the measurement uncertainty	8
4.5.	Equipments Used during the Test	9
5.	<u>TEST CONDITIONS AND RESULTS</u>	11
5.1.	Antenna Requirement	11
5.2.	Conducted Emissions (AC Main)	12
5.3.	Spurious Emissions (radiated)	15
6.	<u>TEST SETUP PHOTOS</u>	18
7.	<u>EXTERANAL AND INTERNAL PHOTOS</u>	19

1. TEST STANDARDS AND REPORT VERSION

1.1. Test Standards

The tests were performed according to following standards:

[FCC Rules Part 15.247](#): Frequency Hopping, Direct Spread Spectrum and Hybrid Systems that are in operation within the bands of 902-928 MHz, 2400-2483.5 MHz, and 5725-5850 MHz

[ANSI C63.10:2013](#): American National Standard for Testing Unlicensed Wireless Devices

[KDB 558074 D01 DTS Meas Guidance v04](#): Guidance for Performing Compliance Measurements on Digital Transmission Systems (DTS) Operating under §15.247

1.2. Report version

Version No.	Date of issue	Description
00	Feb.07,2018	Original

2. TEST DESCRIPTION

Test Item	FCC Rule	Result	Test Engineer
Antenna requirement	15.203/15.247(c)	Pass	William Wang
Line Conducted Emissions (AC Main)	15.207	Pass	William Wang
Spurious Emissions	15.209	Pass	William Wang

Note: The measurement uncertainty is not included in the test result.

3. SUMMARY

3.1. Client Information

Applicant:	Bak USA Technologies Corp.
Address:	425 Michigan Avenue, Buffalo, New York 14203, USA
Manufacturer:	Bak USA Technologies Corp.
Address:	425 Michigan Avenue, Buffalo, New York 14203, USA

3.2. Product Description

Name of EUT:	Tablet PC
Trade Mark:	-
Model No.:	LTE Barcode 1.0
Listed Model(s):	-
Power supply:	DC 3.7V From exchange battery
Adapter information:	Input: 100-240Va.c., 50/60Hz, 0.6A Output: 5Vd.c., 5A
Hardware version:	1.0
Software version:	1607
Bluetooth	
Version:	Supported BT4.0+BLE
Modulation:	GFSK
Operation frequency:	2402MHz~2480MHz
Channel number:	40
Channel separation:	2MHz
Antenna type:	Integral antenna
Antenna gain:	2.0dBi

3.3. Operation state

➤ Test frequency list

According to section 15.31(m), regards to the operating frequency range over 10 MHz, must select three channel which were tested. the Lowest frequency, the middle frequency, and the highest frequency of channel were selected to perform the test, please see the above gray bottom.

Channel	Frequency (MHz)
00	2402
01	2404
⋮	⋮
19	2440
⋮	⋮
38	2478
39	2480

➤ Test mode

For RF test items
The engineering test program was provided and enabled to make EUT continuous transmit (duty cycle>98%).
For AC power line conducted emissions:
The EUT was set to connect with the Bluetooth instrument under large package sizes transmission.
For Radiated suprious emissions test item:
The engineering test program was provided and enabled to make EUT continuous transmit(duty cycle>98%). The EUT in each of three orthogonal axis emissions had been tested ,but only the worst case (X axis) data Recorded in the report.

3.4. EUT configuration

The following peripheral devices and interface cables were connected during the measurement:

- - supplied by the manufacturer
- - supplied by the lab

/	Manufacturer:	/
	Model No.:	/
/	Manufacturer:	/
	Model No.:	/

3.5. Modifications

No modifications were implemented to meet testing criteria.

4. TEST ENVIRONMENT

4.1. Address of the test laboratory

Laboratory: Shenzhen Huatongwei International Inspection Co., Ltd.

Address: 1/F, Bldg 3, Hongfa Hi-tech Industrial Park, Genyu Road, Tianliao, Gongming, Shenzhen, China

4.2. Test Facility

CNAS-Lab Code: L1225

Shenzhen Huatongwei International Inspection Co., Ltd. has been assessed and proved to be in compliance with CNAS-CL01 Accreditation Criteria for Testing and Calibration Laboratories (identical to ISO/IEC17025: 2005 General Requirements) for the Competence of Testing and Calibration Laboratories.

A2LA-Lab Cert. No.: 3902.01

Shenzhen Huatongwei International Inspection Co., Ltd. EMC Laboratory has been accredited by A2LA for technical competence in the field of electrical testing, and proved to be in compliance with ISO/IEC 17025: 2005 General Requirements for the Competence of Testing and Calibration Laboratories and any additional program requirements in the identified field of testing.

FCC-Registration No.: 762235

Shenzhen Huatongwei International Inspection Co., Ltd. EMC Laboratory has been registered and fully described in a report filed with the FCC (Federal Communications Commission). The acceptance letter from the FCC is maintained in our files.

IC-Registration No.:5377B-1

Two 3m Alternate Test Site of Shenzhen Huatongwei International Inspection Co., Ltd. has been registered by Certification and Engineering Bureau of Industry Canada for the performance of radiated measurements with Registration No.: 5377B-1.

ACA

Shenzhen Huatongwei International Inspection Co., Ltd. EMC Laboratory can also perform testing for the Australian C-Tick mark as a result of our A2LA accreditation.

4.3. Environmental conditions

During the measurement the environmental conditions were within the listed ranges:

Temperature:	15~35°C
Relative Humidity:	30~60 %
Air Pressure:	950~1050mba

4.4. Statement of the measurement uncertainty

The data and results referenced in this document are true and accurate. The reader is cautioned that there may be errors in calibration limits of the equipment and facilities. The measurement uncertainty was calculated for all measurements listed in this test report according to TR-100028-01 "Electromagnetic compatibility and Radio spectrum Matters (ERM); Uncertainties in the measurement of mobile radio equipment characteristics; Part 1" and TR-100028-02 "Electromagnetic compatibility and Radio spectrum Matters (ERM); Uncertainties in the measurement of mobile radio equipment characteristics; Part 2" and is documented in the Shenzhen Huatongwei International Inspection Co., Ltd. quality system according to ISO/IEC 17025. Furthermore, component and process variability of devices similar to that tested may result in additional deviation. The manufacturer has the sole responsibility of continued compliance of the device.

Here after the best measurement capability for Shenzhen Huatongwei International Inspection Co., Ltd. is reported:

Test Items	Measurement Uncertainty	Notes
Transmitter power conducted	0.57 dB	(1)
Transmitter power Radiated	2.20 dB	(1)
Conducted spurious emissions 9kHz~40GHz	1.60 dB	(1)
Radiated spurious emissions 9kHz~40GHz	2.20 dB	(1)
Conducted Emissions 9kHz~30MHz	3.39 dB	(1)
Radiated Emissions 30~1000MHz	4.24 dB	(1)
Radiated Emissions 1~18GHz	5.16 dB	(1)
Radiated Emissions 18~40GHz	5.54 dB	(1)

(1) This uncertainty represents an expanded uncertainty expressed at approximately the 95% confidence level using a coverage factor of $k=1.96$.

4.5. Equipments Used during the Test

Conducted Emissions						
Item	Test Equipment	Manufacturer	Model No.	Serial No.	Last Cal. (mm-dd-yy)	Next Cal. (mm-dd-yy)
1	EMI Test Receiver	R&S	ESCI	101247	11/11/2017	11/10/2018
2	Artificial Mains	SCHWARZBECK	NNLK 8121	573	11/11/2017	11/10/2018
3	Pulse Limiter	R&S	ESH3-Z2	101488	11/11/2017	11/10/2018
4	Test Software	R&S	ES-K1	N/A	N/A	N/A
5	RF Connection Cable	HUBER+SUHNER	EF400	N/A	11/21/2017	11/20/2018
6	Single Balanced Telecom Pair ISN	FCC	FCC-TLISN-T2-02	20371	11/11/2017	11/10/2018
7	Two Balanced Telecom Pairs ISN	FCC	FCC-TLISN-T4-02	20373	11/11/2017	11/10/2018
8	Four Balanced Telecom Pairs ISN	FCC	FCC-TLISN-T8-02	20375	11/11/2017	11/10/2018
9	V-Network	R&S	ESH3-Z6	100211	11/11/2017	11/10/2018
10	V-Network	R&S	ESH3-Z6	100210	11/11/2017	11/10/2018
11	2-Line V-Network	R&S	ESH3-Z5	100049	11/11/2017	11/10/2018

Radiated Emissions						
Item	Test Equipment	Manufacturer	Model No.	Serial No.	Last Cal. (mm-dd-yy)	Next Cal. (mm-dd-yy)
1	EMI Test Receiver	R&S	ESCI	101247	11/11/2017	11/10/2018
2	Loop Antenna	R&S	HFH2-Z2	100020	11/20/2017	11/19/2018
3	Ultra-Broadband Antenna	SCHWARZBECK	VULB9163	538	4/5/2017	4/4/2018
4	Horn Antenna	SCHWARZBECK	9120D	1011	3/27/2017	3/26/2018
5	Horn Antenna	SCHWARZBECK	BBHA9170	25841	3/27/2017	3/26/2018
6	Preamplifier	SCHWARZBECK	BBV 9743	9743-0022	10/18/2017	10/17/2018
7	Broadband Preamplifier	SCHWARZBECK	BBV 9718	9718-248	10/18/2017	10/17/2018
8	High pass filter	Compliance Direction systems	BSU-6	34202	11/11/2017	11/10/2018
9	Turntable	MATURO	TT2.0	/	N/A	N/A
10	Antenna Mast	MATURO	TAM-4.0-P	/	N/A	N/A
11	EMI Test Software	R&S	ESK1	N/A	N/A	N/A
12	EMI Test	Audix	E3	N/A	N/A	N/A

	Software					
13	RF Connection Cable	HUBER+SUHNER	3m 3GHz S	N/A	11/21/2017	11/20/2018
14	RF Connection Cable	HUBER+SUHNER	3m 3GHz RG	N/A	11/21/2017	11/20/2018
15	RF Connection Cable	HUBER+SUHNER	6m 18GHz S	N/A	11/21/2017	11/20/2018

RF Conducted Method						
Item	Test Equipment	Manufacturer	Model No.	Serial No.	Last Cal. (mm-dd-yy)	Next Cal. (mm-dd-yy)
1	Spectrum Analyzer	R&S	FSV40	100048	11/11/2017	11/10/2018
2	OSP	R&S	OSP120	101317	N/A	N/A
3	OSP	R&S	OSP-B157	100890	N/A	N/A
4	Signal generator	R&S	SMB100A	177956	11/11/2017	11/10/2018
5	Vector signal generator	R&S	SMBV100A	260790	7/20/2017	7/19/2018
6	EXA Signal Analyzer	Agilent	N9020A	184247	9/22/2017	9/21/2018
7	Power Meter	Agilent	U2021XA	178231	9/22/2017	9/21/2018
8	DAQ Device	Agilent	U2531A	132812	9/22/2017	9/21/2018

The Cal.Interval was one year.

5. TEST CONDITIONS AND RESULTS

5.1. Antenna Requirement

Requirement

FCC CFR Title 47 Part 15 Subpart C Section 15.203:

An intentional radiator shall be designed to ensure that no antenna other than that furnished by the responsible party shall be used with the device. The use of a permanently attached antenna or of an antenna that uses a unique coupling to the intentional radiator, the manufacturer may design the unit so that a broken antenna can be replaced by the user, but the use of a standard antenna jack or electrical connector is prohibited.

FCC CFR Title 47 Part 15 Subpart C Section 15.247(c) (1)(i):

(i) Systems operating in the 2400-2483.5 MHz band that is used exclusively for fixed. Point-to-point operations may employ transmitting antennas with directional gain greater than 6 dBi provided the maximum conducted output power of the intentional radiator is reduced by 1 dB for every 3 dB that the directional gain of the antenna exceeds 6 dBi.

TEST RESULTS

Passed **Not Applicable**

The directional gain of the antenna less than 6 dBi, please refer to the below antenna photo.

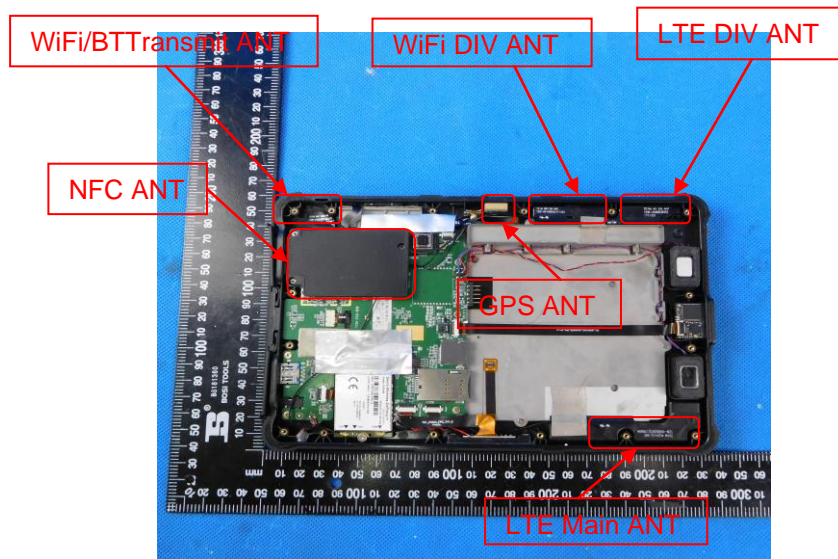

5.2. Conducted Emissions (AC Main)

LIMIT

FCC CFR Title 47 Part 15 Subpart C Section 15.207

Frequency range (MHz)	Limit (dBuV)	
	Quasi-peak	Average
0.15-0.5	66 to 56*	56 to 46*
0.5-5	56	46
5-30	60	50

* Decreases with the logarithm of the frequency.

TEST CONFIGURATION

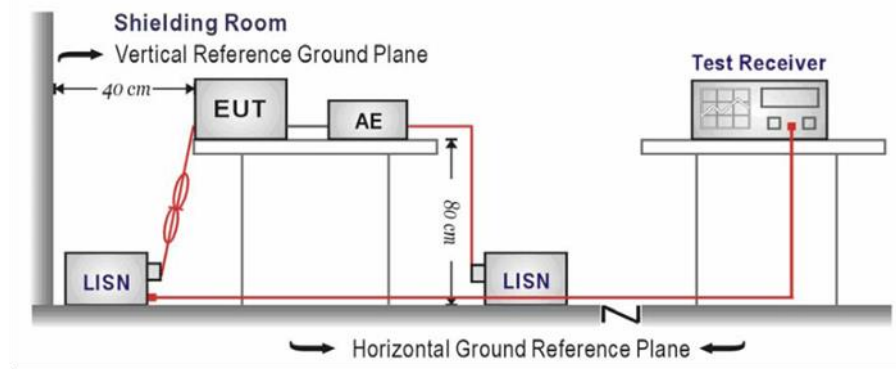

TEST PROCEDURE

1. The EUT was setup according to ANSI C63.10:2013 requirements.
2. The EUT was placed on a platform of nominal size, 1 m by 1.5 m, raised 80 cm above the conducting ground plane. The vertical conducting plane was located 40 cm to the rear of the EUT. All other surfaces of EUT were at least 80 cm from any other grounded conducting surface.
3. The EUT and simulators are connected to the main power through a line impedances stabilization network (LISN). The LISN provides a 50 ohm /50uH coupling impedance for the measuring equipment.
4. The peripheral devices are also connected to the main power through a LISN. (Please refer to the block diagram of the test setup and photographs)
5. Each current-carrying conductor of the EUT power cord, except the ground (safety) conductor, was individually connected through a LISN to the input power source.
6. The excess length of the power cord between the EUT and the LISN receptacle were folded back and forth at the center of the lead to form a bundle not exceeding 40 cm in length.
7. Conducted emissions were investigated over the frequency range from 0.15MHz to 30MHz using a receiver bandwidth of 9 kHz.
8. During the above scans, the emissions were maximized by cable manipulation.

TEST MODE:

Please refer to the clause 3.3

TEST RESULTS

Passed Not Applicable

Note:

- 1) Transd = Cable lose + Pulse Limiter Factor + Artificial Mains Factor
- 2) Margin = Limit - Level

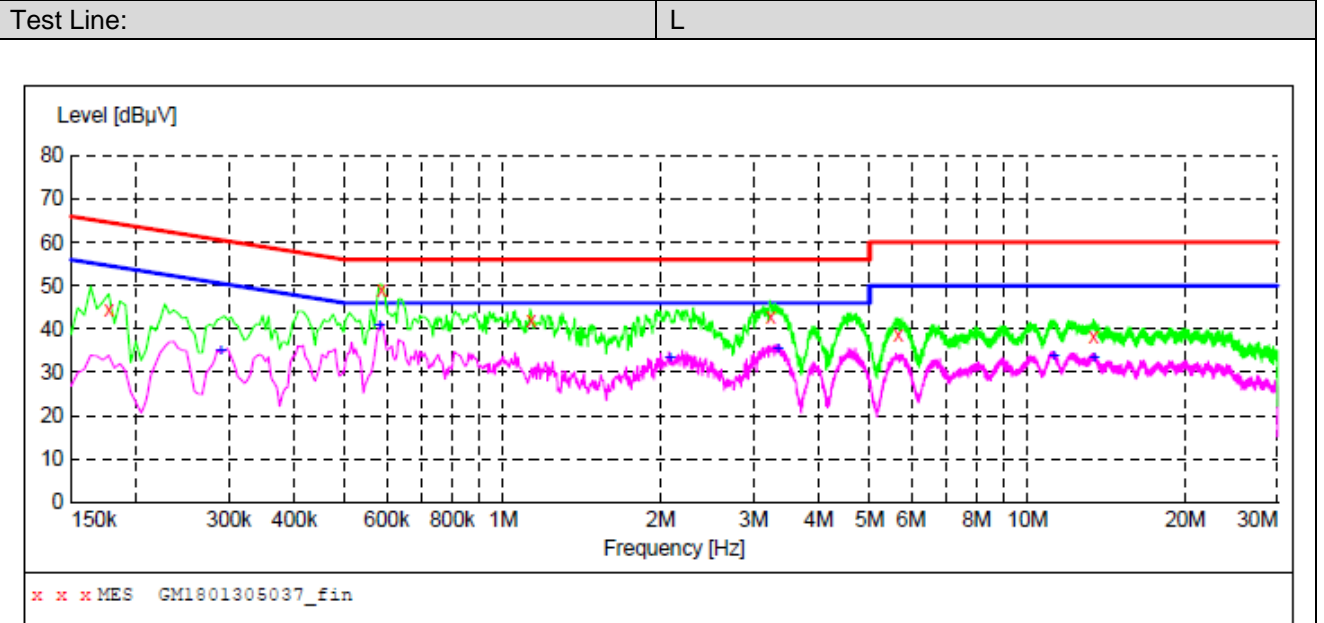

MEASUREMENT RESULT: "GM1801305037_fin"

1/30/2018 1:33PM

Frequency MHz	Level dBµV	Transd dB	Limit dBµV	Margin dB	Detector	Line	PE
0.177000	44.30	10.0	65	20.3	QP	L1	GND
0.586500	49.10	10.0	56	6.9	QP	L1	GND
1.131000	42.00	10.1	56	14.0	QP	L1	GND
3.237000	42.80	10.1	56	13.2	QP	L1	GND
5.676000	38.50	10.2	60	21.5	QP	L1	GND
13.380000	38.30	10.5	60	21.7	QP	L1	GND

MEASUREMENT RESULT: "GM1801305037_fin2"

1/30/2018 1:33PM

Frequency MHz	Level dBµV	Transd dB	Limit dBµV	Margin dB	Detector	Line	PE
0.289500	34.80	9.9	51	15.7	AV	L1	GND
0.582000	40.80	10.0	46	5.2	AV	L1	GND
2.080500	33.40	10.1	46	12.6	AV	L1	GND
3.340500	35.40	10.1	46	10.6	AV	L1	GND
11.215500	33.80	10.4	50	16.2	AV	L1	GND
13.398000	33.40	10.5	50	16.6	AV	L1	GND

Test Line: N

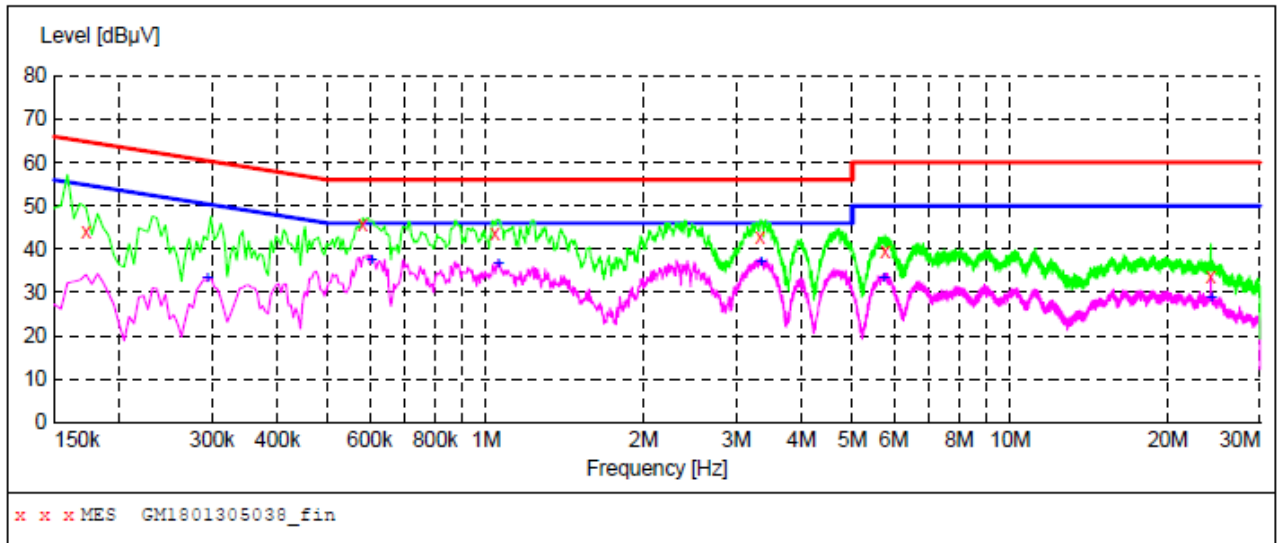

MEASUREMENT RESULT: "GM1801305038_fin"

1/30/2018 1:36PM

Frequency MHz	Level dBµV	Transd dB	Limit dBµV	Margin dB	Detector	Line	PE
0.172500	44.20	10.0	65	20.6	QP	N	GND
0.582000	45.70	10.0	56	10.3	QP	N	GND
1.041000	43.60	10.1	56	12.4	QP	N	GND
3.336000	42.90	10.1	56	13.1	QP	N	GND
5.770500	39.40	10.2	60	20.6	QP	N	GND
24.157500	33.80	10.8	60	26.2	QP	N	GND

MEASUREMENT RESULT: "GM1801305038_fin2"

1/30/2018 1:36PM

Frequency MHz	Level dBµV	Transd dB	Limit dBµV	Margin dB	Detector	Line	PE
0.294000	33.10	9.9	50	17.3	AV	N	GND
0.604500	37.60	10.0	46	8.4	AV	N	GND
1.054500	36.50	10.1	46	9.5	AV	N	GND
3.349500	36.90	10.1	46	9.1	AV	N	GND
5.748000	33.20	10.2	50	16.8	AV	N	GND
24.193500	28.80	10.8	50	21.2	AV	N	GND

5.3. Spurious Emissions (radiated)

LIMIT

FCC CFR Title 47 Part 15 Subpart C Section 15.209

Frequency	Limit (dBuV/m @3m)	Value
30MHz~88MHz	40.00	Quasi-peak
88MHz~216MHz	43.50	Quasi-peak
216MHz~960MHz	46.00	Quasi-peak
960MHz~1GHz	54.00	Quasi-peak
Above 1GHz	54.00	Average
	74.00	Peak

TEST CONFIGURATION

- 9 kHz ~ 30 MHz

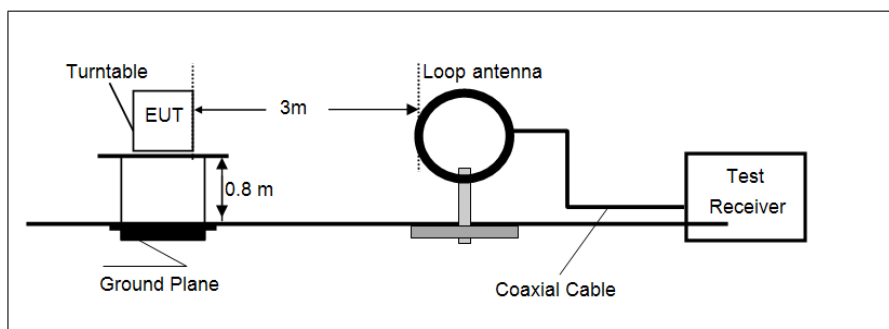

- 30 MHz ~ 1 GHz

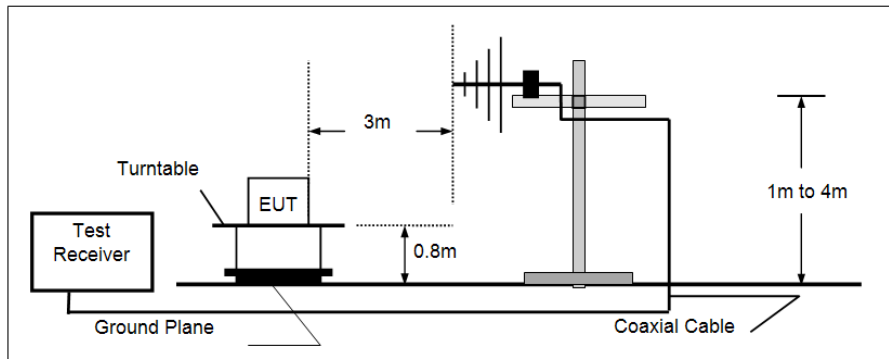

- Above 1 GHz

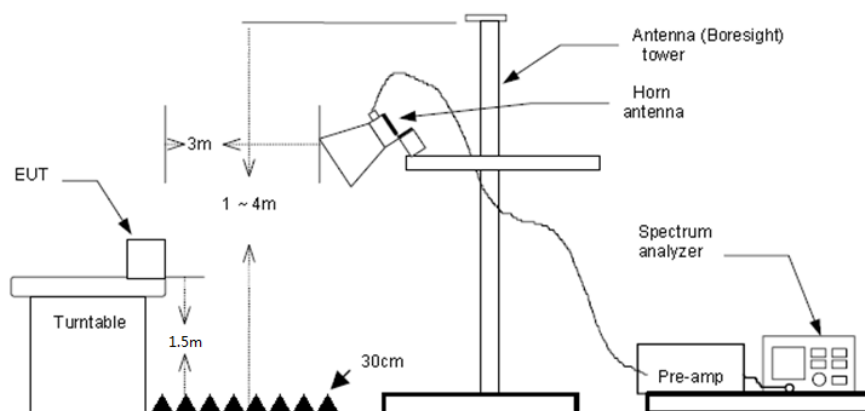

TEST PROCEDURE

1. The EUT was setup and tested according to ANSI C63.10:2013 for compliance to FCC 47CFR 15.247 requirements.
2. The EUT is placed on a turn table which is 0.8 meter above ground for below 1 GHz, and 1.5 m for above 1 GHz. The turn table is rotated 360 degrees to determine the position of the maximum emission level.
3. The EUT was positioned such that the distance from antenna to the EUT was 3 meters.
4. The antenna is scanned from 1 meter to 4 meters to find out the maximum emission level. This is repeated for both horizontal and vertical polarization of the antenna. In order to find the maximum emission, all of the interface cables were manipulated according to ANSI C63.10:2013 on radiated measurement.
5. Use the following spectrum analyzer settings
 - (1) Span shall wide enough to fully capture the emission being measured;
 - (2) Below 1 GHz, RBW=120 kHz, VBW=300 kHz, Sweep=auto, Detector function=peak, Trace=max hold;
If the emission level of the EUT measured by the peak detector is 3 dB lower than the applicable limit, the peak emission level will be reported. Otherwise, the emission measurement will be repeated using the quasi-peak detector and reported.
 - (3) Above 1GHz, RBW=1MHz, VBW=3MHz Peak detector for Peak value.
RBW=1MHz, VBW=3MHz RMS detector for Average value.

TEST MODE:

Please refer to the clause 3.3

TEST RESULTS

Passed **Not Applicable**

Note:

- 1) Above 1GHz Final Level =Receiver Read level + Antenna Factor + Cable Loss – Preamplifier Factor
 - 2) The emission levels of other frequencies are very lower than the limit and not show in test report.
- **9 kHz ~ 30 MHz**
The EUT was pre-scanned the frequency band (9 kHz ~ 30 MHz), found the radiated level lower than the limit, so don't show on the report.
- **30 MHz ~ 1000 MHz**
Have pre-scan all modulation mode, found the BT-BLE mode CH39 which it was worst case, so only the worst case's data on the test report.

➤ 30 MHz ~ 1 GHz

Polarization: Vertical

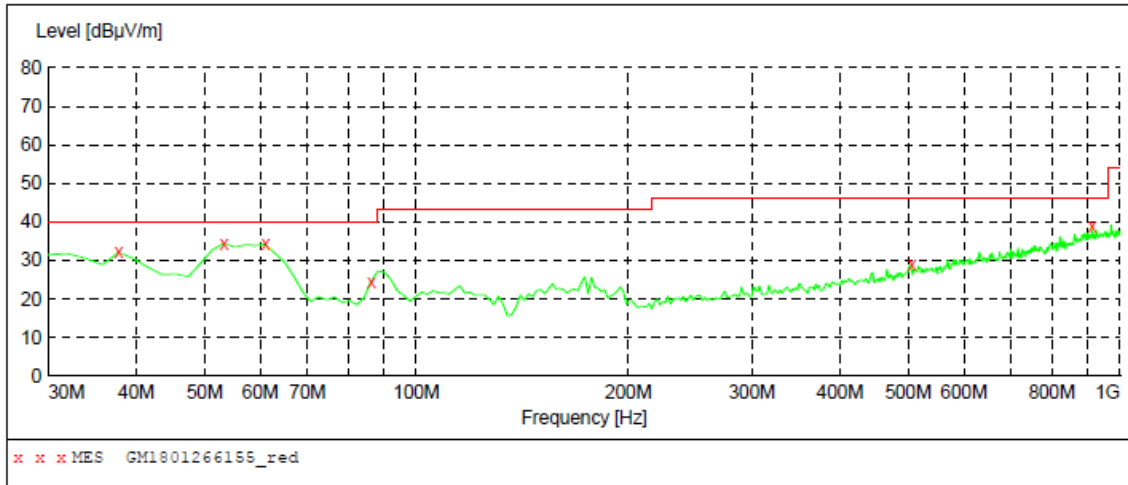

MEASUREMENT RESULT: "GM1801266155_red"

1/26/2018 9:47PM

Frequency MHz	Level dBµV/m	Transd dB	Limit dBµV/m	Margin dB	Det.	Height cm	Azimuth deg	Polarization
37.760000	32.10	-10.8	40.0	7.9	QP	100.0	7.00	VERTICAL
53.280000	34.40	-9.0	40.0	5.6	QP	100.0	22.00	VERTICAL
61.040000	34.20	-10.3	40.0	5.8	QP	100.0	315.00	VERTICAL
86.260000	24.60	-14.1	40.0	15.4	QP	100.0	275.00	VERTICAL
505.300000	28.80	-1.6	46.0	17.2	QP	100.0	0.00	VERTICAL
912.700000	39.00	6.9	46.0	7.0	QP	100.0	166.00	VERTICAL

Polarization: Horizontal

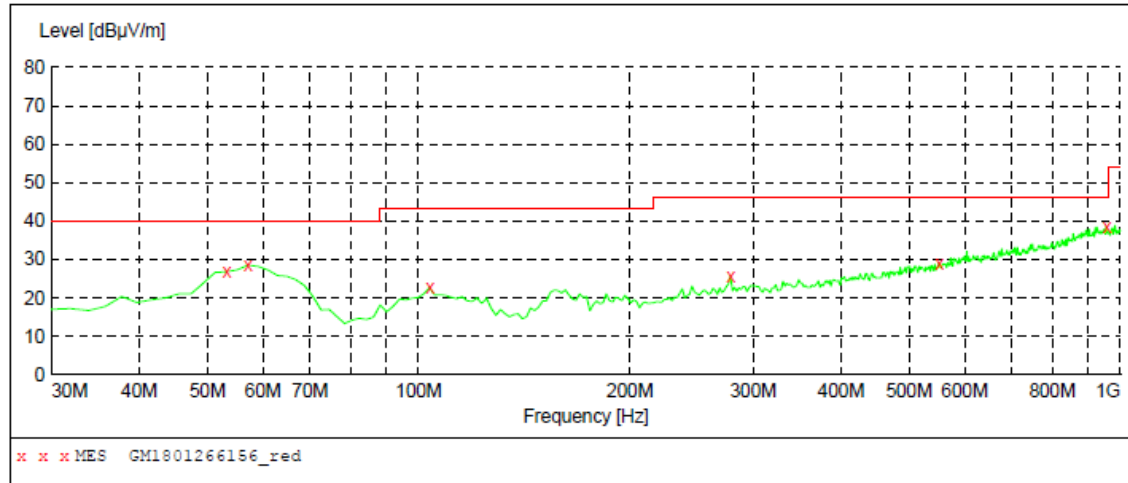

MEASUREMENT RESULT: "GM1801266156_red"

1/26/2018 9:50PM

Frequency MHz	Level dBµV/m	Transd dB	Limit dBµV/m	Margin dB	Det.	Height cm	Azimuth deg	Polarization
53.280000	26.80	-9.0	40.0	13.2	QP	300.0	44.00	HORIZONTAL
57.160000	28.60	-9.4	40.0	11.4	QP	300.0	218.00	HORIZONTAL
103.720000	22.70	-10.5	43.5	20.8	QP	300.0	247.00	HORIZONTAL
278.320000	25.50	-7.8	46.0	20.5	QP	100.0	91.00	HORIZONTAL
551.860000	29.10	-0.7	46.0	16.9	QP	300.0	360.00	HORIZONTAL
955.380000	38.50	7.3	46.0	7.5	QP	100.0	171.00	HORIZONTAL

6. TEST SETUP PHOTOS

Conducted Emissions (AC Mains)



Radiated Emissions



7. EXTERANAL AND INTERNAL PHOTOS

Reference to the test report No.: TRE1801017101.

.....**End of Report**.....