



MEASUREMENT REPORT

FCC PART 15.247 Bluetooth BLE

FCC ID: 2AEY7-S8A002

APPLICANT: Bak USB Technologies Corp.

Application Type: Certification

Product: MID

Model No.: Seal 8 pro

FCC Classification: Digital Transmission System (DTS)

FCC Rule Part(s): Part 15.247

Test Procedure(s): ANSI C63.10-2013, KDB 558074 D01v03r05

Test Date: November 08, 2017 ~ March 25, 2017

Reviewed By
Manager :

Robin Wu

(Robin Wu)

Approved By
CEO :

Marlin Chen

(Marlin Chen)



The test results relate only to the samples tested.

This equipment has been shown to be capable of compliance with the applicable technical standards as indicated in the measurement report and was tested in accordance with the measurement procedures specified in KDB 558074 D01v03r05. Test results reported herein relate only to the item(s) tested.

The test report shall not be reproduced except in full without the written approval of MRT Technology (Suzhou) Co., Ltd.

Revision History

Report No.	Version	Description	Issue Date	Note
1611RSU01003	Rev. 01	Initial report	03-26-2017	Valid

CONTENTS

Description	Page
1. INTRODUCTION	6
1.1. Scope	6
1.2. MRT Test Location	6
2. PRODUCT INFORMATION	7
2.1. Feature of Equipment under Test	7
2.2. Product Specification Subjective to this Report.....	7
2.3. Working Frequencies.....	8
2.4. Device Capabilities	9
2.5. Test Configuration	9
2.6. EMI Suppression Device(s)/Modifications.....	9
2.7. Labeling Requirements.....	9
2.8. Test Software	9
3. DESCRIPTION OF TEST	10
3.1. Evaluation Procedure	10
3.2. AC Line Conducted Emissions	10
3.3. Radiated Emissions.....	11
4. ANTENNA REQUIREMENTS.....	12
5. TEST EQUIPMENT CALIBRATION DATE.....	13
6. MEASUREMENT UNCERTAINTY.....	14
7. TEST RESULT	15
7.1. Summary	15
7.2. 6dB Bandwidth Measurement.....	16
7.2.1. Test Limit	16
7.2.2. Test Procedure used.....	16
7.2.3. Test Setting.....	16
7.2.4. Test Setup.....	16
7.2.5. Test Result.....	17
7.3. Output Power Measurement.....	18
7.3.1. Test Limit	18
7.3.2. Test Procedure Used	18
7.3.3. Test Setting.....	18
7.3.4. Test Setup.....	18
7.3.5. Test Result of Output Power	19
7.4. Power Spectral Density Measurement.....	20

7.4.1.	Test Limit	20
7.4.2.	Test Procedure Used	20
7.4.3.	Test Setting	20
7.4.4.	Test Setup.....	20
7.4.5.	Test Result.....	21
7.5.	Conducted Band Edge and Out-of-Band Emissions.....	22
7.5.1.	Test Limit	22
7.5.2.	Test Procedure Used	22
7.5.3.	Test Setting.....	22
7.5.4.	Test Setup.....	23
7.5.5.	Test Result.....	24
7.6.	Radiated Spurious Emission Measurement	26
7.6.1.	Test Limit	26
7.6.2.	Test Procedure Used	26
7.6.3.	Test Setting.....	26
7.6.4.	Test Setup.....	28
7.6.5.	Test Result.....	30
7.7.	Radiated Restricted Band Edge Measurement	35
7.7.1.	Test Result.....	35
7.8.	AC Conducted Emissions Measurement.....	43
7.8.1.	Test Limit	43
7.8.2.	Test Setup.....	43
7.8.3.	Test Result.....	44
8.	CONCLUSION.....	44

§2.1033 General Information

Applicant:	Bak USB Technologies Corp.
Applicant Address:	425 Michigan Avenue, Buffalo, NY 14203, USA
Manufacturer:	Shenzhen Wisky Technology Co., Ltd.
Manufacturer Address:	5th Floor, W2-A Building, Hi-tech Park South 1st Road, Nanshan District, Shenzhen, China
Test Site:	MRT Technology (Suzhou) Co., Ltd
Test Site Address:	D8 Building, Youxin Industrial Park, No.2 Tian'edang Rd., Wuzhong Economic Development Zone, Suzhou, China
MRT Registration No.:	809388
FCC Rule Part(s):	Part 15.247
Model No.:	Seal 8 pro
FCC ID:	2AEY7-S8A002
Test Device Serial No.:	N/A <input type="checkbox"/> Production <input checked="" type="checkbox"/> Pre-Production <input type="checkbox"/> Engineering
FCC Classification:	Digital Transmission System (DTS)

Test Facility / Accreditations

Measurements were performed at MRT Laboratory located in Tian'edang Rd., Suzhou, China.

- MRT facility is a FCC registered (MRT Reg. No. 809388) test facility with the site description report on file and has met all the requirements specified in Section 2.948 of the FCC Rules.
- MRT facility is an IC registered (MRT Reg. No. 11384A-1) test laboratory with the site description on file at Industry Canada.
- MRT facility is a VCCI registered (R-4179, G-814, C-4664, T-2206) test laboratory with the site description on file at VCCI Council.
- MRT Lab is accredited to ISO 17025 by the American Association for Laboratory Accreditation (A2LA) under the American Association for Laboratory Accreditation Program (A2LA Cert. No. 3628.01) in EMC, Telecommunications and Radio testing for FCC, Industry Canada, EU and TELEC Rules.



1. INTRODUCTION

1.1. Scope

Measurement and determination of electromagnetic emissions (EMC) of radio frequency devices including intentional and/or unintentional radiators for compliance with the technical rules and regulations of the Federal Communications Commission and the Industry Canada Certification and Engineering Bureau.

1.2. MRT Test Location

The map below shows the location of the MRT LABORATORY, its proximity to the Taihu Lake. These measurement tests were conducted at the MRT Technology (Suzhou) Co., Ltd. Facility located at D8 Building, Youxin Industrial Park, No.2 Tian'edang Rd., Wuzhong Economic Development Zone, Suzhou, China. The detailed description of the measurement facility was found to be in compliance with the requirements of § 2.948 according to ANSI C63.4-2009 on September 30, 2013.



2. PRODUCT INFORMATION

2.1. Feature of Equipment under Test

Product Name	MID
FCC ID	2AEY7-S8A002
Model No.	Seal 8 pro
LTE Specification	LTE Band 2 / 4 / 5 / 13 / 17
Wi-Fi Specification	802.11a//b/g/n/ac
Bluetooth Version	v4.0 dual mode
NFC	13.56MHz
RF ID	920.25 ~ 924.75MHz
Components	
Adapter	M/N: BCT050500-C02U INPUT: 100-240V ~ 50/60Hz, 0.6A Max OUTPUT: 5Vdc, 5.0A

2.2. Product Specification Subjective to this Report

Bluetooth Frequency	2402~2480MHz
Bluetooth Version	v4.0
Type of modulation	FHSS
Data Rate	1Mbps(GFSK)
Antenna Type	PIFA Antenna
Antenna Gain	3.21dBi

Note: For other features of this EUT, test report will be issued separately.

2.3. Working Frequencies

Channel List for BLE

Channel	Frequency	Channel	Frequency	Channel	Frequency
00	2402 MHz	01	2404 MHz	02	2406 MHz
03	2408 MHz	04	2410 MHz	05	2412 MHz
06	2414 MHz	07	2416 MHz	08	2418 MHz
09	2420 MHz	10	2422 MHz	11	2424 MHz
12	2426 MHz	13	2428 MHz	14	2430 MHz
15	2432 MHz	16	2434 MHz	17	2436 MHz
18	2438 MHz	19	2440 MHz	20	2442 MHz
21	2444 MHz	22	2446 MHz	23	2448 MHz
24	2450 MHz	25	2452 MHz	26	2454 MHz
27	2456 MHz	28	2458 MHz	29	2460 MHz
30	2462 MHz	31	2464 MHz	32	2466 MHz
33	2468 MHz	34	2470 MHz	35	2472 MHz
36	2474 MHz	37	2476 MHz	38	2478 MHz
39	2480 MHz	--	--	--	--

2.4. Device Capabilities

This device contains the following capabilities:

5GHz WLAN (UNII), 2.4GHz WLAN (DTS), Bluetooth (v4.0 Dual mode), Multi-Band LTE, RF ID, NFC

2.5. Test Configuration

The **MID** was tested per the guidance of KDB 558074 D01v03r05. ANSI C63.10-2013 was used to reference the appropriate EUT setup for radiated spurious emissions testing and AC line conducted testing.

2.6. EMI Suppression Device(s)/Modifications

No EMI suppression device(s) were added and/or no modifications were made during testing.

2.7. Labeling Requirements

Per 2.1074 & 15.19; Docket 95-19

The label shall be permanently affixed at a conspicuous location on the device; instruction manual or pamphlet supplied to the user and be readily visible to the purchaser at the time of purchase.

However, when the device is so small wherein placement of the label with specified statement is not practical, only the FCC ID must be displayed on the device per Section 15.19(a)(5). Please see attachment for FCC ID label and label location.

2.8. Test Software

The test utility software used during testing was engineering directive ordered by applicant.

3. DESCRIPTION OF TEST

3.1. Evaluation Procedure

The measurement procedures described in the American National Standard for Testing Unlicensed Wireless Devices (ANSI C63.10-2013), and the guidance provided in KDB 558074 D01v03r05 were used in the measurement of the **MID**.

Deviation from measurement procedure.....None

3.2. AC Line Conducted Emissions

The line-conducted facility is located inside an 8'x4'x4' shielded enclosure. A 1m x 2m wooden table 80cm high is placed 40cm away from the vertical wall and 80cm away from the sidewall of the shielded room. Two 10kHz-30MHz, 50Ω/50uH Line-Impedance Stabilization Networks (LISNs) are bonded to the shielded room floor. Power to the LISNs is filtered by external high-current high-insertion loss power line filters. These filters attenuate ambient signal noise from entering the measurement lines. These filters are also bonded to the shielded enclosure.

The EUT is powered from one LISN and the support equipment is powered from the second LISN. All interconnecting cables more than 1 meter were shortened to a 1 meter length by non-inductive bundling (serpentine fashion) and draped over the back edge of the test table. All cables were at least 40cm above the horizontal reference ground-plane. Power cables for support equipment were routed down to the second LISN while ensuring that that cables were not draped over the second LISN.

Sufficient time for the EUT, support equipment, and test equipment was allowed in order for them to warm up to their normal operating condition. The RF output of the LISN was connected to the receiver and exploratory measurements were made to determine the frequencies producing the maximum emission from the EUT. The receiver was scanned from 150kHz to 30MHz. The detector function was set to peak mode for exploratory measurements while the bandwidth of the analyzer was set to 9kHz. The EUT, support equipment, and interconnecting cables were arranged and manipulated to maximize each emission. Each emission was also maximized by varying: power lines, the mode of operation or data exchange speed, or support equipment whichever determined the worst-case emission. Once the worst case emissions have been identified, the one EUT cable configuration/arrangement and mode of operation that produced these emissions were used for final measurements on the same test site. The analyzer is set to CISPR quasi-peak and average detectors with a 9kHz resolution bandwidth for final measurements.

An extension cord was used to connect to a single LISN which powered by EUT. The extension cord was calibrated with LISN, the impedance and insertion loss are compliance with the requirements as stated in ANSI C63.10-2013.

Line conducted emissions test results are shown in Section 7.8.

3.3. Radiated Emissions

The radiated test facilities consisted of an indoor 3 meter semi-anechoic chamber used for final measurements and exploratory measurements, when necessary. The measurement area is contained within the semi-anechoic chamber which is shielded from any ambient interference. For measurements above 1GHz absorbers are arranged on the floor between the turn table and the Antenna mast in such a way so as to maximize the reduction of reflections. For measurements below 1GHz, the absorbers are removed. A MF Model 210SS turntable is used for radiated measurement. It is a continuously rotatable, remote controlled, metallic turntable and 2 meters (6.56 ft.) in diameter. The turn table is flush with the raised floor of the chamber in order to maintain its function as a ground plane. An 80cm high PVC support structure is placed on top of the turntable. For all measurements, the spectrum was scanned through all EUT azimuths and from 1 to 4 meter receive Antenna height using a broadband Antenna from 30MHz up to the upper frequency shown in 15.33(b)(1) depending on the highest frequency generated or used in the device or on which the device operates or tunes. For frequencies above 1GHz, linearly polarized double ridge horn Antennas were used. For frequencies below 30MHz, a calibrated loop Antenna was used. When exploratory measurements were necessary, they were performed at 1 meter test distance inside the semi-anechoic chamber using broadband Antennas, broadband amplifiers, and spectrum analyzers to determine the frequencies and modes producing the maximum emissions. Sufficient time for the EUT, support equipment, and test equipment was allowed in order for them to warm up to their normal operating condition. The test set-up for frequencies below 1GHz was placed on top of the 0.8 meter high, 1 x 1.5 meter table; and test set-up for frequencies 1-40GHz was placed on top of the 1.5 meter high, 1 x 1.5 meter table. The EUT, support equipment, and interconnecting cables were arranged and manipulated to maximize each emission. Appropriate precaution was taken to ensure that all emissions from the EUT were maximized and investigated. The system configuration, clock speed, mode of operation or video resolution, if applicable, turntable azimuth, and receive Antenna height was noted for each frequency found.

Final measurements were made in the semi-anechoic chamber using calibrated, linearly polarized broadband and horn Antennas. The test setup was configured to the setup that produced the worst case emissions. The spectrum analyzer was set to investigate all frequencies required for testing to compare the highest radiated disturbances with respect to the specified limits. The turntable containing the EUT was rotated through 360 degrees and the height of the receive Antenna was varied 1 to 4 meters and stopped at the azimuth and height producing the maximum emission. Each emission was maximized by changing the orientation of the EUT through three orthogonal planes and changing the polarity of the receive Antenna, whichever produced the worst-case emissions. According to 3dB Beam-Width of horn Antenna, the horn Antenna should be always directed to the EUT when rising height.

4. ANTENNA REQUIREMENTS

Excerpt from §15.203 of the FCC Rules/Regulations:

“An intentional radiator antenna shall be designed to ensure that no antenna other than that furnished by the responsible party can be used with the device. The use of a permanently attached antenna or of an antenna that uses a unique coupling to the intentional radiator shall be considered sufficient to comply with the provisions of this section.”

- The antenna of the **MID** is **permanently attached**.
- There are no provisions for connection to an external antenna.

Conclusion:

The **MID** unit complies with the requirement of §15.203.

5. TEST EQUIPMENT CALIBRATION DATE

Conducted Emissions - SR2

Instrument	Manufacturer	Type No.	Serial No.	Cali. Interval	Cali. Due Date
EMI Test Receiver	R&S	ESR7	102030	1 year	2017/05/08
Two-Line V-Network	R&S	ENV216	101683	1 year	2017/06/21
Two-Line V-Network	R&S	ENV216	101684	1 year	2017/06/21
Temperature/Humidity Meter	Yuhuaze	HTC-2	N/A	1 year	2017/12/22
Shielding Anechoic Chamber	MIX-BEP	Chamber-SR2	N/A	1 year	2017/05/10

Radiated Emissions - AC2

Instrument	Manufacturer	Type No.	Serial No.	Cali. Interval	Cali. Due Date
MXE EMI Receiver	Agilent	N9038A	MY51210182	1 year	2017/08/03
Broadband Coaxial Preamplifier	Schwarzbeck	BBV 9718	MY52090106	1 year	2017/12/10
Preamplifier	Schwarzbeck	BBV 9721	9721-008	1 year	2017/04/16
Loop Antenna	Schwarzbeck	FMZB1519	100982	1 year	2017/12/21
TRILOG Antenna	Schwarzbeck	VULB9162	9162-047	1 year	2017/10/22
Broad-Band Horn Antenna	Schwarzbeck	BBHA9120D	1457	1 year	2017/11/19
Broadband Horn Antenna	Schwarzbeck	BBHA9170	BBHA9170549	1 year	2018/01/04
Digital Thermometer & Hygrometer	Minggao	ETH529	N/A	1 year	2017/11/30
Anechoic Chamber	RIKEN	Chamber-AC2	N/A	1 year	2017/05/10

Conducted Test Equipment - TR3

Instrument	Manufacturer	Type No.	Serial No.	Cali. Interval	Cali. Due Date
Spectrum Analyzer	Agilent	N9020A	MY52090106	1 year	2017/05/08
USB wideband power sensor	Boonton	55006	8911	1 year	2017/05/08
Temperature/Humidity Meter	Yuhuaze	HTC-2	N/A	1 year	2017/12/22

Software	Version	Function
e3	V8.3.5	EMI Test Software

6. MEASUREMENT UNCERTAINTY

Where relevant, the following test uncertainty levels have been estimated for tests performed on the EUT as specified in CISPR 16-4-2. This uncertainty represents an expanded uncertainty expressed at approximately the 95% confidence level using a coverage factor of $k = 2$.

AC Conducted Emission Measurement - SR2
Measuring Uncertainty for a Level of Confidence of 95% ($U=2Uc(y)$): 150kHz~30MHz: 3.46dB
Radiated Emission Measurement - AC2
Measuring Uncertainty for a Level of Confidence of 95% ($U=2Uc(y)$): 9kHz ~ 1GHz: 4.18dB 1GHz ~ 25GHz: 4.76dB

7. TEST RESULT

7.1. Summary

Company Name: Bak USB Technologies Corp.
FCC ID: N/A
FCC Classification: Digital Transmission System (DTS)
Data Rate(s) Tested: 1Mbps(GFSK) (BLE)

FCC Part Section(s)	Test Description	Test Limit	Test Condition	Test Result	Reference
15.247(a)(2)	6dB Bandwidth	$\geq 500\text{kHz}$	Conducted	Pass	Section 7.2
15.247(b)(3)	Output Power	$\leq 1\text{Watt}$		Pass	Section 7.3
15.247(e)	Power Spectral Density	$\leq 8\text{dBm} / 3\text{kHz}$		Pass	Section 7.4
15.247(d)	Band Edge / Out-of-Band Emissions	$\geq 20\text{dBc(Peak)}$		Pass	Section 7.5
15.205 15.209	General Field Strength Limits (Restricted Bands and Radiated Emission Limits)	Emissions in restricted bands must meet the radiated limits detailed in 15.209	Radiated	Pass	Section 7.6 & 7.7
15.207	AC Conducted Emissions 150kHz - 30MHz	< FCC 15.207 limits	Line Conducted	Pass	Section 7.8

Notes:

- 1) All modes of operation and data rates were investigated. For radiated emission test, every axis (X, Y, Z) was also verified. The test results shown in the following sections represent the worst case emissions.
- 2) The analyzer plots shown in this section were all taken with a correction table loaded into the analyzer. The correction table was used to account for the losses of the cables and attenuators used as part of the system to connect the EUT to the analyzer at all frequencies of interest.
- 3) All antenna port conducted emissions testing was performed on a test bench with the antenna port of the EUT connected to the spectrum analyzer through calibrated cables and attenuators.

7.2. 6dB Bandwidth Measurement

7.2.1. Test Limit

The minimum 6dB bandwidth shall be at least 500 kHz.

7.2.2. Test Procedure used

KDB 558074 D01v03r05 - Section 8.2 Option 2

7.2.3. Test Setting

1. The Spectrum's automatic bandwidth measurement capability was used to perform the 6dB bandwidth measurement. The "X" dB bandwidth parameter was set to $X = 6$. The bandwidth measurement was not influenced by any intermediate power nulls in the fundamental emission.
2. Set RBW = 100 kHz
3. VBW $\geq 3 \times$ RBW
4. Detector = Peak
5. Trace mode = max hold
6. Sweep = auto couple
7. Allow the trace was allowed to stabilize

7.2.4. Test Setup

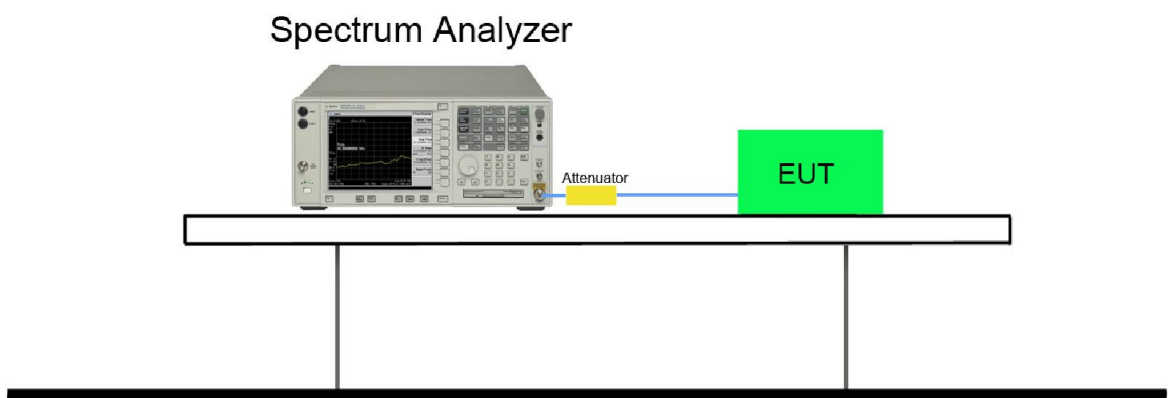

7.2.5. Test Result

Test Mode	Data Rate (Mbps)	Channel No.	Frequency (MHz)	6dB Bandwidth (MHz)	Limit (MHz)	Result
BLE	1	00	2402	0.51	≥ 0.5	Pass
BLE	1	19	2440	0.51	≥ 0.5	Pass
BLE	1	39	2480	0.51	≥ 0.5	Pass

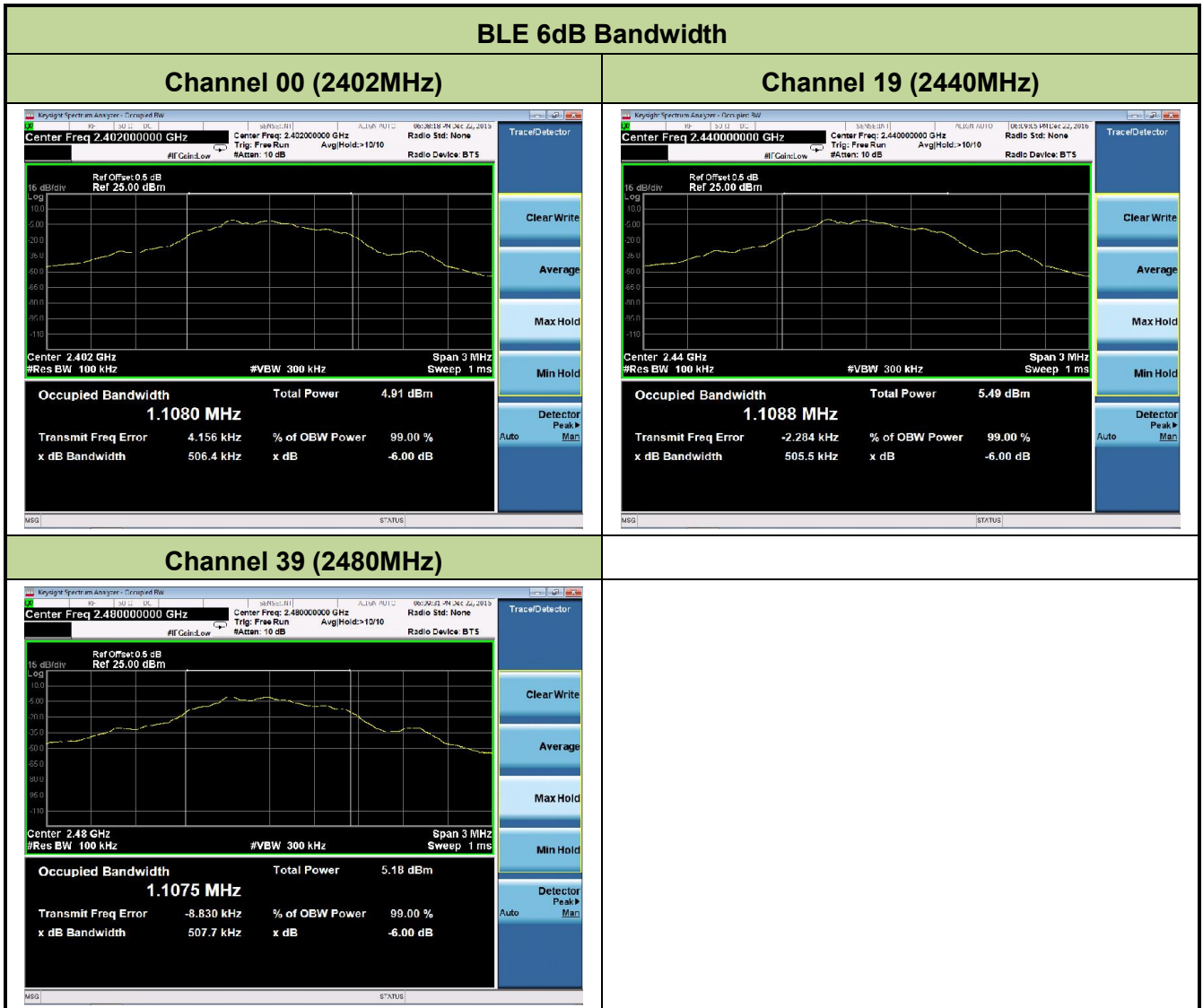

7.3. Output Power Measurement

7.3.1. Test Limit

The maximum out power shall be less 1 Watt (30dBm).

7.3.2. Test Procedure Used

KDB 558074 D01v03r05 - Section 9.1.2 PKPM1 - Peak Power Method

7.3.3. Test Setting

Method PKPM1 (Peak Power Measurement of Signals with DTS BW \leq 50MHz)

Peak power measurements were performed only when the EUT was transmitting at its maximum power control level using a broadband power meter with a pulse sensor. The pulse sensor employs a VBW = 50MHz so this method was only used for signals whose DTS bandwidth was less than or equal to 50MHz.

7.3.4. Test Setup

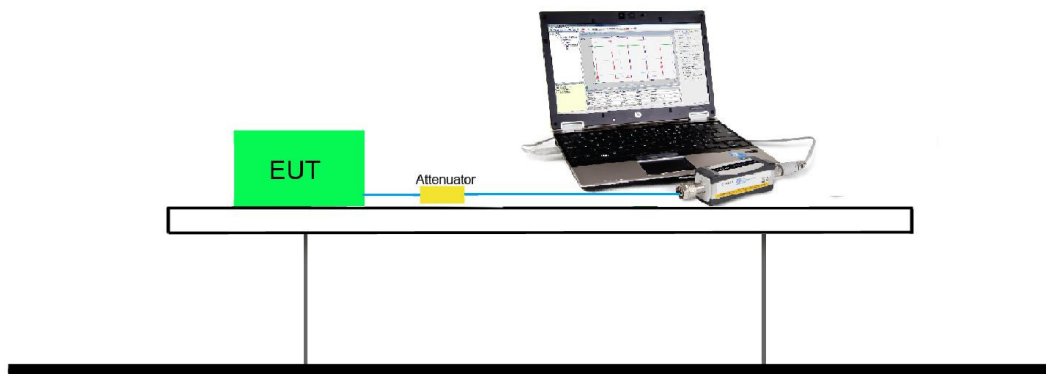

7.3.5. Test Result of Output Power

Test Result of Peak Output Power

Test Mode	Data Rate (Mbps)	Channel No.	Frequency (MHz)	Peak Power (dBm)	Limit (dBm)	Result
BLE	1	00	2402	0.12	≤ 30	Pass
BLE	1	19	2440	0.71	≤ 30	Pass
BLE	1	39	2480	0.36	≤ 30	Pass

Test Result of Average Output Power (Reporting Only)

Test Mode	Data Rate (Mbps)	Channel No.	Frequency (MHz)	Average Power (dBm)	Limit (dBm)	Result
BLE	1	00	2402	-0.31	≤ 30	Pass
BLE	1	19	2440	0.25	≤ 30	Pass
BLE	1	39	2480	-0.13	≤ 30	Pass

7.4. Power Spectral Density Measurement

7.4.1. Test Limit

The maximum permissible power spectral density is 8dBm in any 3 kHz band.

7.4.2. Test Procedure Used

KDB 558074 D01v03r05 - Section 10.2 Method PKPSD

7.4.3. Test Setting

1. Analyzer was set to the center frequency of the DTS channel under investigation
2. Span = 1.5 times the DTS channel bandwidth
3. RBW = 3kHz
4. VBW = 10kHz
5. Detector = peak
6. Sweep time = auto couple
7. Trace mode = max hold
8. Trace was allowed to stabilize

7.4.4. Test Setup

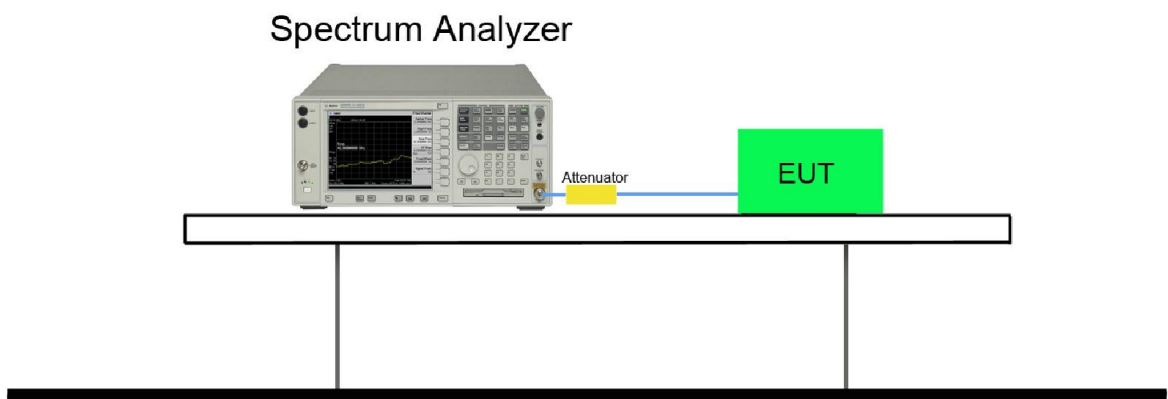

7.4.5. Test Result

Test Mode	Data Rate (Mbps)	Channel No.	Frequency (MHz)	PSD Result (dBm / 3kHz)	Limit (dBm / 3kHz)	Result
BLE	1	00	2402	-17.60	≤ 8	Pass
BLE	1	19	2440	-17.00	≤ 8	Pass
BLE	1	39	2480	-17.25	≤ 8	Pass

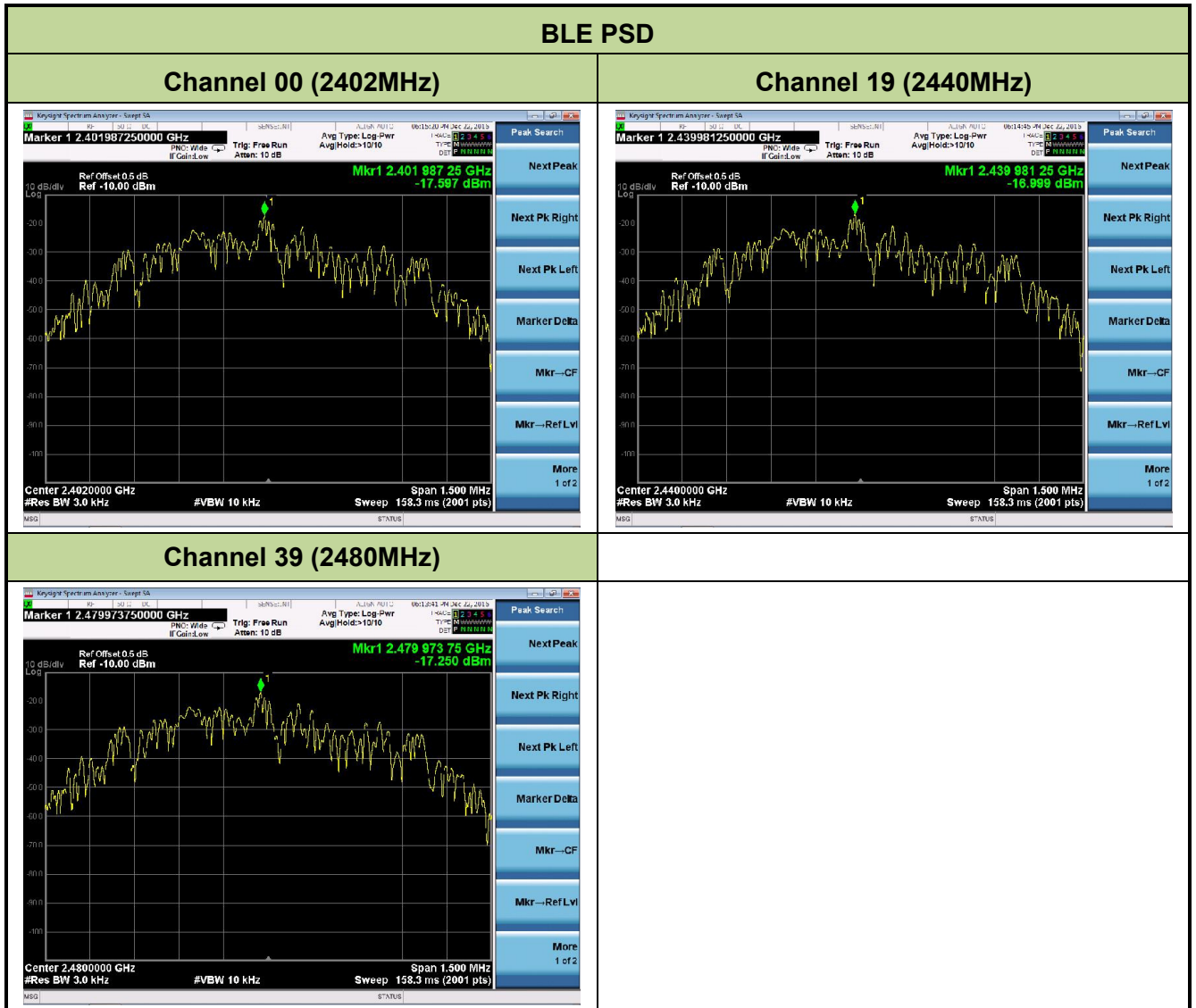

7.5. Conducted Band Edge and Out-of-Band Emissions

7.5.1. Test Limit

The limit for out-of-band spurious emissions at the band edge is 20dB below the fundamental emission level, as determined from the in-band power measurement of the DTS channel performed in a 100kHz bandwidth per the PSD procedure.

7.5.2. Test Procedure Used

KDB 558074 D01v03r05 - Section 11.2 & Section 11.3

7.5.3. Test Setting

1. Reference level measurement

- (a) Set instrument center frequency to DTS channel center frequency
- (b) Set the span to ≥ 1.5 times the DTS bandwidth
- (c) Set the RBW = 100 kHz
- (d) Set the VBW $\geq 3 \times$ RBW
- (e) Detector = peak
- (f) Sweep time = auto couple
- (g) Trace mode = max hold
- (h) Allow trace to fully stabilize

2. Emission level measurement

- (a) Set the center frequency and span to encompass frequency range to be measured
- (b) RBW = 100kHz
- (c) VBW = 300kHz
- (d) Detector = Peak
- (e) Number of sweep points $\geq 2 \times$ Span/RBW
- (f) Trace mode = max hold
- (g) Sweep time = auto couple
- (h) The trace was allowed to stabilize

7.5.4. Test Setup

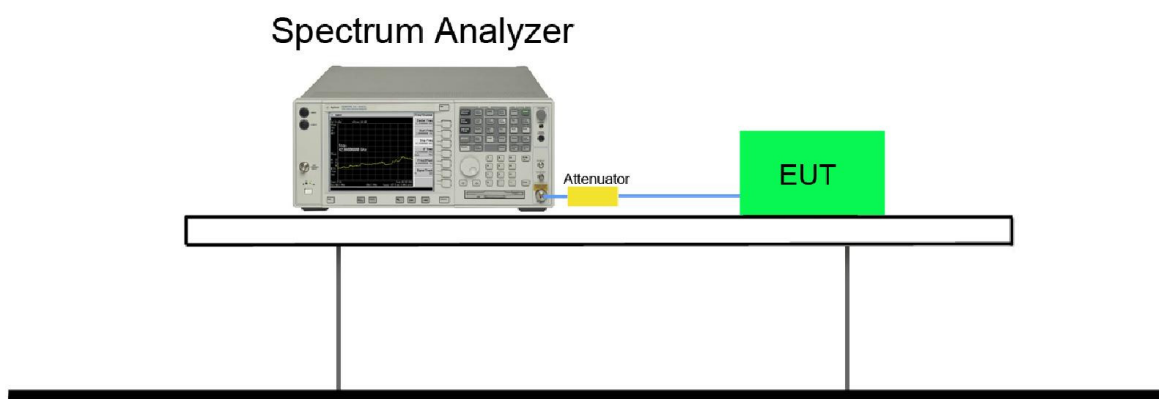

7.5.5. Test Result

Test Mode	Data Rate (Mbps)	Channel No.	Frequency (MHz)	Limit	Result
BLE	1	00	2402	20dBc	Pass
BLE	1	19	2440	20dBc	Pass
BLE	1	39	2480	20dBc	Pass

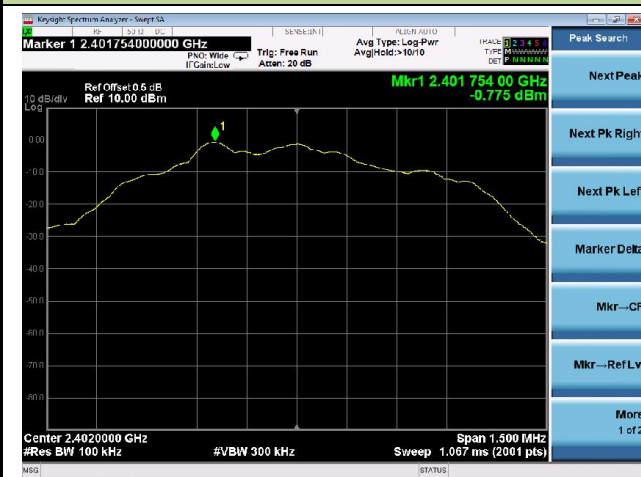
BLE Out-of-Band Emissions
Channel 00 (2402MHz)
100kHz PSD reference Level

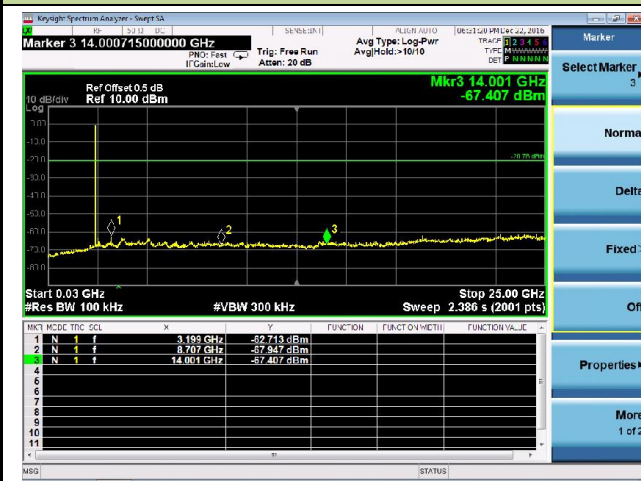
Low Band Edge

Spurious Emission 30MHz ~ 25GHz

Channel 19 (2440MHz)

100kHz PSD reference Level



Spurious Emission 30MHz ~ 25GHz

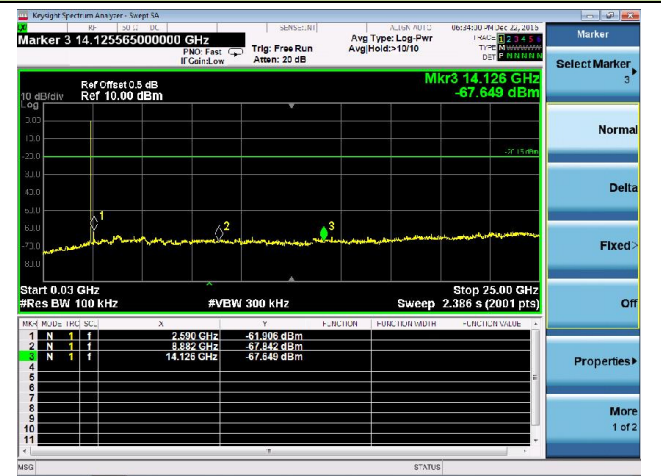

Channel 39 (2480MHz)

100kHz PSD reference Level



High Band Edge

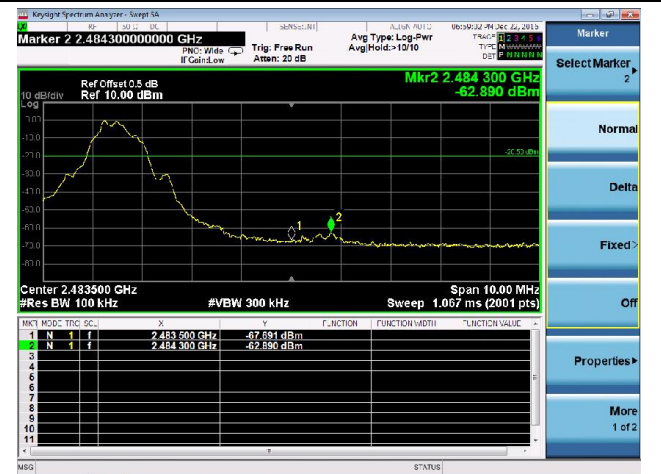

Spurious Emission 30MHz ~ 25GHz

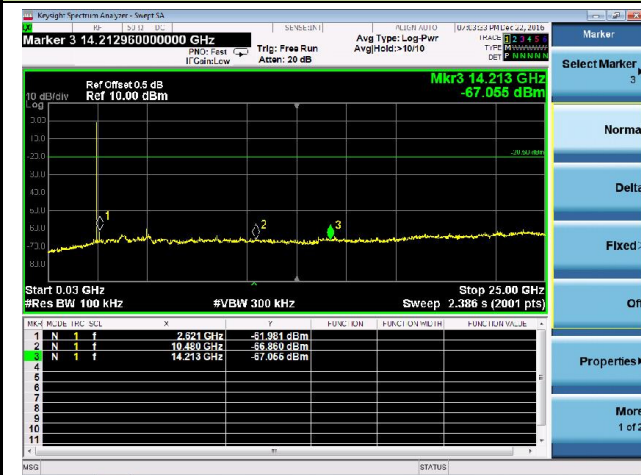

7.6. Radiated Spurious Emission Measurement

7.6.1. Test Limit

All out of band emissions appearing in a restricted band as specified in Section 15.205 of the Title 47 CFR must not exceed the limits shown in Table per Section 15.209.

FCC Part 15 Subpart C Paragraph 15.209		
Frequency [MHz]	Field Strength [uV/m]	Measured Distance [Meters]
0.009 - 0.490	2400/F (kHz)	300
0.490 - 1.705	24000/F (kHz)	30
1.705 - 30	30	30
30 - 88	100	3
88 - 216	150	3
216 - 960	200	3
Above 960	500	3

7.6.2. Test Procedure Used

KDB 558074 D01v03r05 - Section 12.2.3 (quasi-peak measurements)

KDB 558074 D01v03r05 - Section 12.2.4 (peak power measurements)

KDB 558074 D01v03r05 - Section 12.2.5 (average power measurements)

7.6.3. Test Setting

Peak Field Strength Measurements per Section 12.2.4 of KDB 558074 D01v03r05

1. Analyzer center frequency was set to the frequency of the radiated spurious emission of interest
2. RBW = as specified in Table 1
3. VBW = 3MHz
4. Detector = peak
5. Sweep time = auto couple

6. Trace mode = max hold
7. Trace was allowed to stabilize

Table 1 - RBW as a function of frequency

Frequency	RBW
9 ~ 150 kHz	200 ~ 300 Hz
0.15 ~ 30 MHz	9 ~ 10 kHz
30 ~ 1000 MHz	100 ~ 120 kHz
> 1000 MHz	1 MHz

Average Field Strength Measurements per Section 12.2.4 of KDB 558074 D01v03r05

1. Analyzer center frequency was set to the frequency of the radiated spurious emission of interest
2. RBW = 1MHz
3. VBW \geq 1/T
4. De As an alternative, the instrument may be set to linear detector mode. Ensure that video filtering is applied in linear voltage domain (rather than in a log or dB domain). Some instruments require linear display mode in order to accomplish this. Others have a setting for Average-VBW Type, which can be set to "Voltage" regardless of the display mode
5. Detector = Peak
6. Sweep time = auto
7. Trace mode = max hold
8. Allow max hold to run for at least 50 times (1/duty cycle) traces

7.6.4. Test Setup

9kHz ~ 30MHz Test Setup:

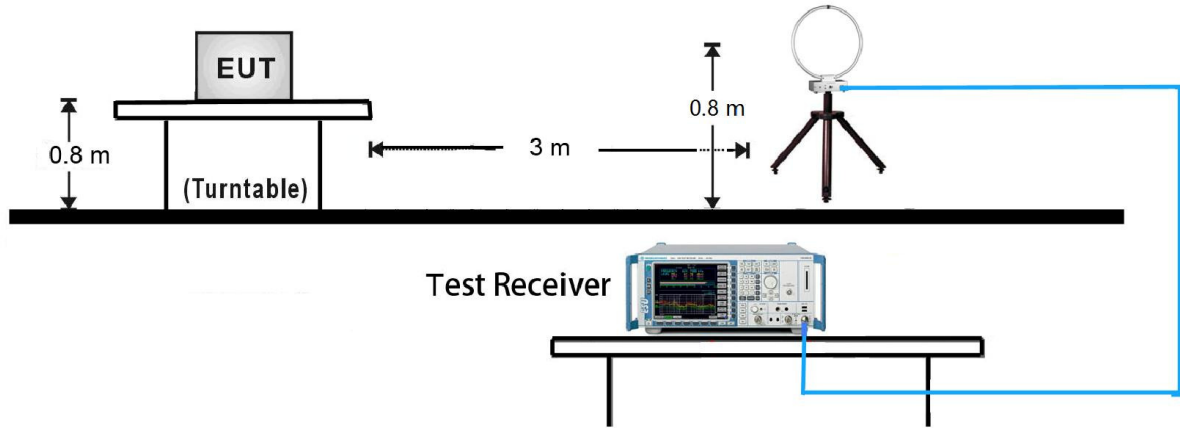

30MHz ~ 1GHz Test Setup:

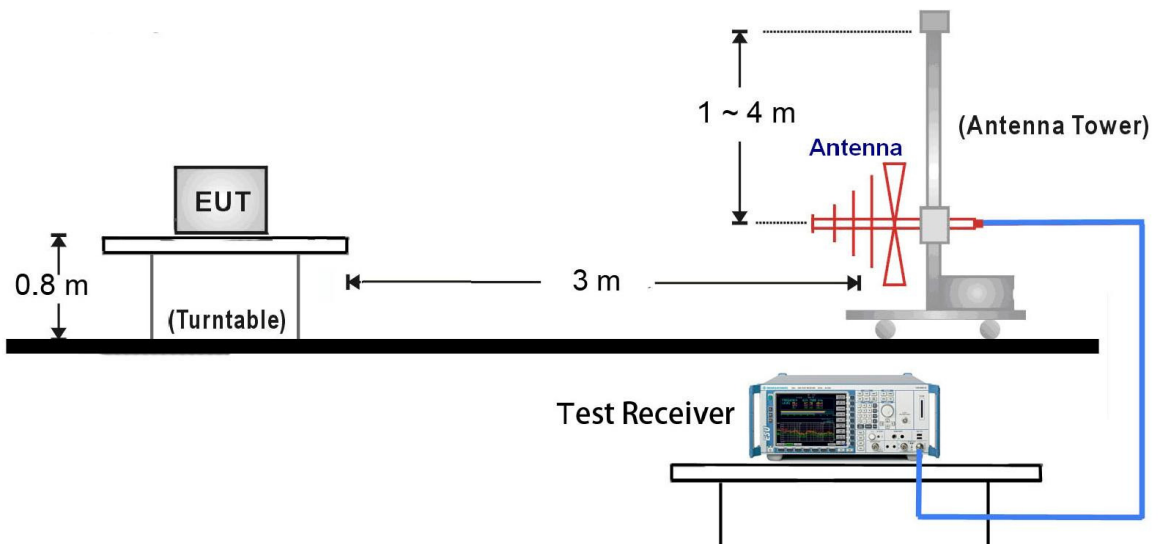

1GHz ~ 18GHz Test Setup:

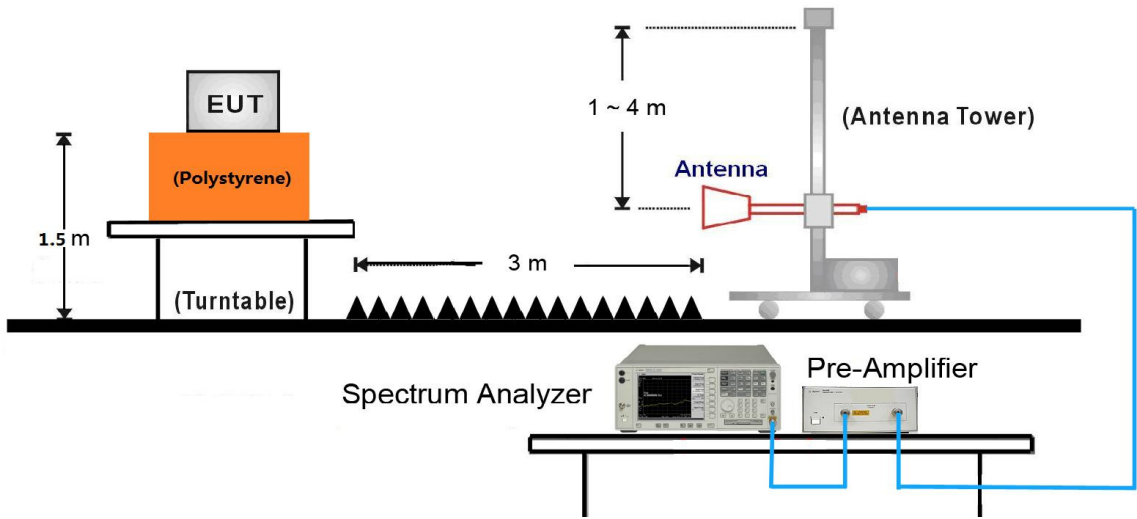

18GHz ~ 25GHz Test Setup:

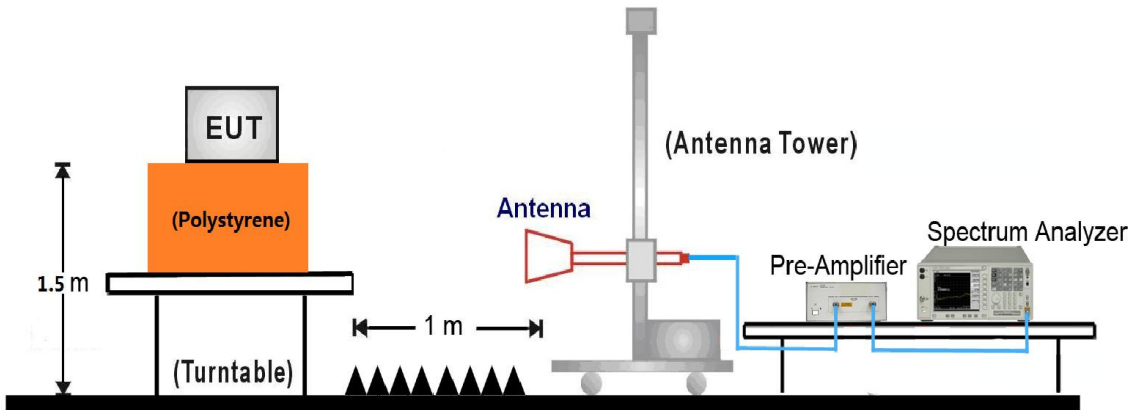

7.6.5. Test Result

Remark: There are the ambient noise within frequency range 9 kHz ~ 30 MHz and 18GHz ~ 25GHz, the permissible value is not show in the report.

Test Mode:	BLE	Test Site:	AC2
Test Channel:	00	Test Engineer:	Bruce Wang
Remark:	1. Average measurement was not performed if peak level lower than average limit. 2. Other frequency was 20dB below limit line within 1-18GHz, there is not show in the report.		

Mark	Frequency (MHz)	Reading Level (dBμV)	Factor (dB)	Measure Level (dBμV/m)	Limit (dBμV/m)	Margin (dB)	Detector	Polarization
	3839.0	37.8	-0.6	37.2	74.0	-36.8	Peak	Horizontal
	4876.0	34.9	2.6	37.5	74.0	-36.5	Peak	Horizontal
*	6584.5	34.5	7.5	42.0	76.0	-34.0	Peak	Horizontal
*	9670.0	34.5	12.6	47.1	76.0	-28.9	Peak	Horizontal
	3839.0	37.8	-0.6	37.2	74.0	-36.8	Peak	Vertical
	4884.5	35.9	2.7	38.6	74.0	-35.4	Peak	Vertical
*	6550.5	33.7	7.4	41.1	76.0	-34.9	Peak	Vertical
*	9865.5	32.1	13.2	45.3	76.0	-30.7	Peak	Vertical

Note 1: "*" is not in restricted band, its limit is 20dBc of the fundamental emission level (96.0dBμV/m) or 15.209 which is higher.

Note 2: Measure Level (dBμV/m) = Reading Level (dBμV) + Factor (dB)

Factor (dB) = Cable Loss (dB) + Antenna Factor (dB/m) - Pre_Amplifier Gain (dB)

Test Mode:	BLE	Test Site:	AC2
Test Channel:	19	Test Engineer:	Bruce Wang
Remark:	1. Average measurement was not performed if peak level lower than average limit. 2. Other frequency was 20dB below limit line within 1-18GHz, there is not show in the report.		

Mark	Frequency (MHz)	Reading Level (dBμV)	Factor (dB)	Measure Level (dBμV/m)	Limit (dBμV/m)	Margin (dB)	Detector	Polarization
	3839.0	39.3	-0.6	38.7	74.0	-35.3	Peak	Horizontal
	4961.0	36.4	2.7	39.1	74.0	-34.9	Peak	Horizontal
*	6644.0	35.1	7.7	42.8	77.5	-34.7	Peak	Horizontal
*	9865.5	33.2	13.2	46.4	77.5	-31.1	Peak	Horizontal
	3754.0	36.5	-0.6	35.9	74.0	-38.1	Peak	Vertical
	4876.0	34.0	2.6	36.6	74.0	-37.4	Peak	Vertical
*	6907.5	34.2	8.4	42.6	77.5	-34.9	Peak	Vertical
*	9882.5	32.7	13.3	46.0	77.5	-31.5	Peak	Vertical

Note 1: "*" is not in restricted band, its limit is 20dBc of the fundamental emission level (97.5dBμV/m) or 15.209 which is higher.

Note 2: Measure Level (dBμV/m) = Reading Level (dBμV) + Factor (dB)

Factor (dB) = Cable Loss (dB) + Antenna Factor (dB/m) - Pre_Amplifier Gain (dB)

Test Mode:	BLE	Test Site:	AC2
Test Channel:	39	Test Engineer:	Bruce Wang
Remark:	1. Average measurement was not performed if peak level lower than average limit. 2. Other frequency was 20dB below limit line within 1-18GHz, there is not show in the report.		

Mark	Frequency (MHz)	Reading Level (dBμV)	Factor (dB)	Measure Level (dBμV/m)	Limit (dBμV/m)	Margin (dB)	Detector	Polarization
	3839.0	38.0	-0.6	37.4	74.0	-36.6	Peak	Horizontal
	4731.5	36.8	2.7	39.5	74.0	-34.5	Peak	Horizontal
*	6414.5	34.6	6.7	41.3	76.6	-35.3	Peak	Horizontal
*	9840.0	32.6	13.5	46.1	76.6	-30.5	Peak	Horizontal
	3839.0	37.0	-0.6	36.4	74.0	-37.6	Peak	Vertical
	4799.5	35.9	2.8	38.7	74.0	-35.3	Peak	Vertical
*	6525.0	33.9	7.3	41.2	76.6	-35.4	Peak	Vertical
*	10120.5	33.5	13.5	47.0	76.6	-29.6	Peak	Vertical

Note 1: "*" is not in restricted band, its limit is 20dBc of the fundamental emission level (96.6dBμV/m) or 15.209 which is higher.

Note 2: Measure Level (dBμV/m) = Reading Level (dBμV) + Factor (dB)

Factor (dB) = Cable Loss (dB) + Antenna Factor (dB/m) - Pre_Amplifier Gain (dB)

The worst case of Radiated Emission below 1GHz:

Site: AC2	Time: 2016/12/24 - 13:24
Limit: FCC_Part15.209_RE(3m)	Engineer: Bruce Wang
Probe: VULB9162_0.03-8GHz	Polarity: Horizontal
EUT: MID	Power: By Battery
Worse Case Mode: Transmit by BLE at channel 2402MHz	

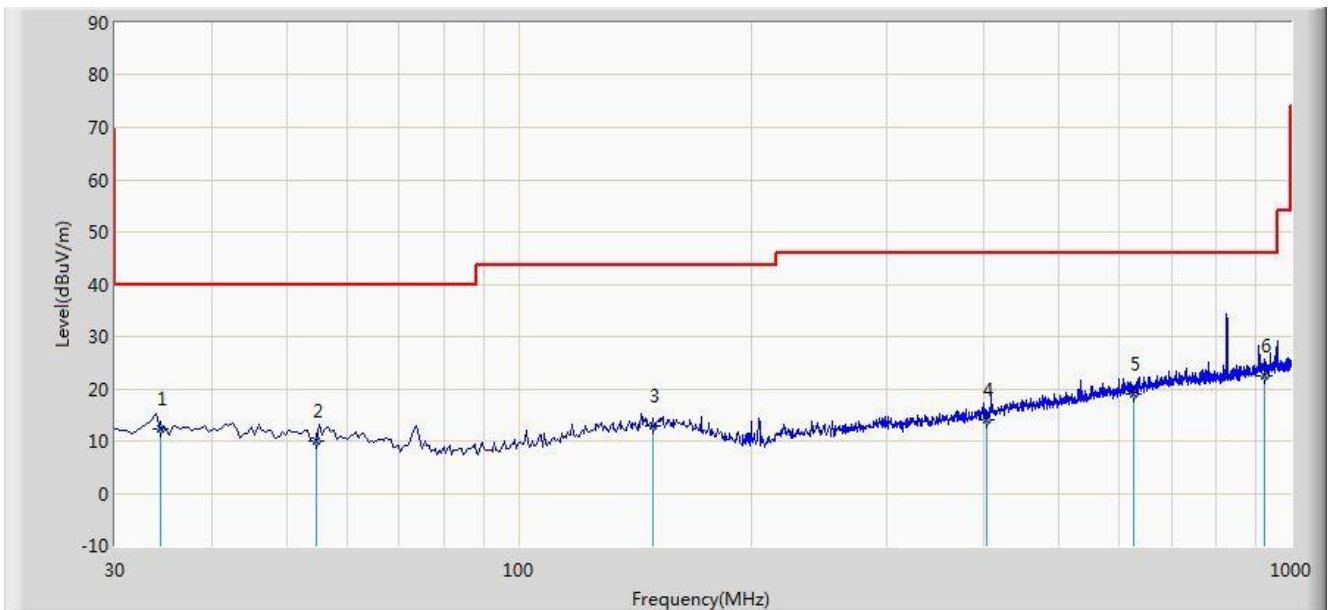

No	Flag	Mark	Frequency (MHz)	Measure Level (dBuV/m)	Reading Level (dBuV)	Over Limit (dB)	Limit (dBuV/m)	Factor (dB)	Type
1			34.365	12.174	-1.633	-27.826	40.000	13.807	QP
2			54.735	10.112	-3.620	-29.888	40.000	13.732	QP
3			149.310	12.794	-2.316	-30.706	43.500	15.110	QP
4			403.450	14.107	-2.474	-31.893	46.000	16.581	QP
5			624.610	19.028	-1.994	-26.972	46.000	21.022	QP
6		*	925.795	22.416	-2.298	-23.584	46.000	24.714	QP

Note: Measure Level (dB μ V/m) = Reading Level (dB μ V) + Factor (dB)

Factor (dB) = Cable Loss (dB) + Antenna Factor (dB/m)

Site: AC2	Time: 2016/12/24 - 13:37
Limit: FCC_Part15.209_RE(3m)	Engineer: Bruce Wang
Probe: VULB9162_0.03-8GHz	Polarity: Vertical
EUT: MID	Power: By Battery
Worse Case Mode: Transmit by BLE at channel 2402MHz	

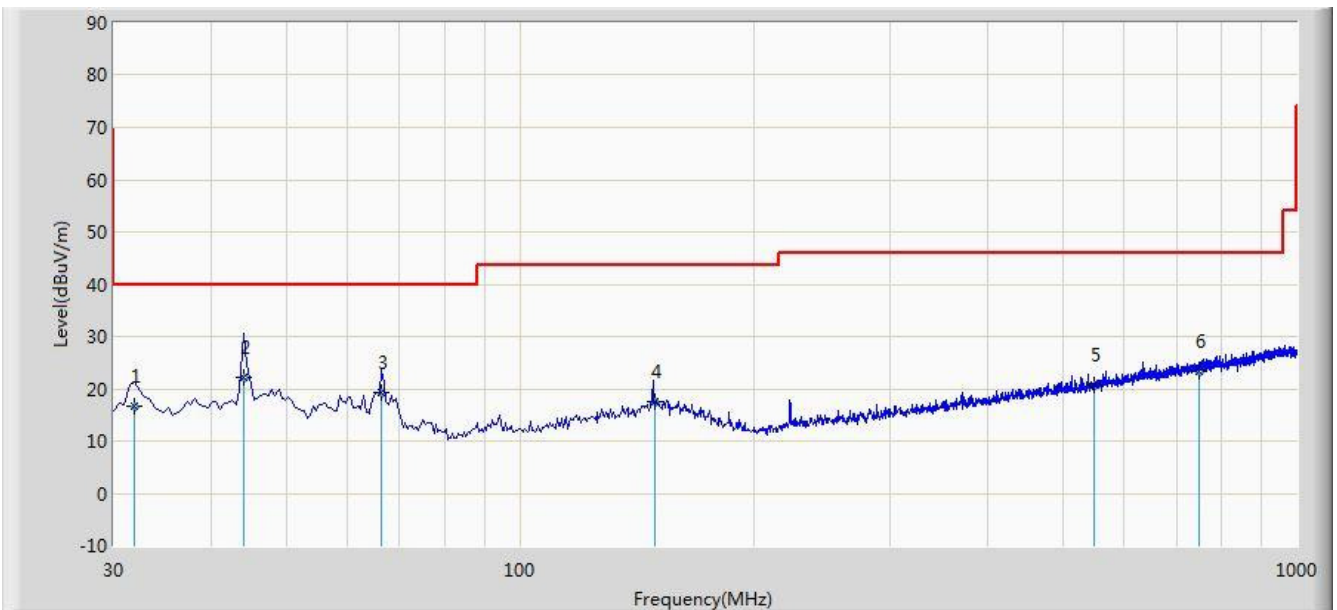

No	Flag	Mark	Frequency (MHz)	Measure Level (dBuV/m)	Reading Level (dBuV)	Over Limit (dB)	Limit (dBuV/m)	Factor (dB)	Type
1		*	33.395	21.763	8.017	-18.237	40.000	13.746	QP
2			79.955	17.302	7.218	-22.698	40.000	10.084	QP
3			154.645	12.377	-2.809	-31.123	43.500	15.186	QP
4			533.430	22.396	3.250	-23.604	46.000	19.146	QP
5			728.855	23.673	1.245	-22.327	46.000	22.428	QP
6			955.380	26.171	1.245	-19.829	46.000	24.926	QP

Note: Measure Level (dB μ V/m) = Reading Level (dB μ V) + Factor (dB)

Factor (dB) = Cable Loss (dB) + Antenna Factor (dB/m)

7.7. Radiated Restricted Band Edge Measurement

7.7.1. Test Result

Site: AC2	Time: 2016/12/24 - 14:42
Limit: FCC_Part15.209_RE(3m)	Engineer: Vince Yu
Probe: BBHA9120D_1-18GHz	Polarity: Horizontal
EUT: MID	Power: AC 120V/60Hz
Test Mode: Transmit by BLE at Channel 2402MHz	

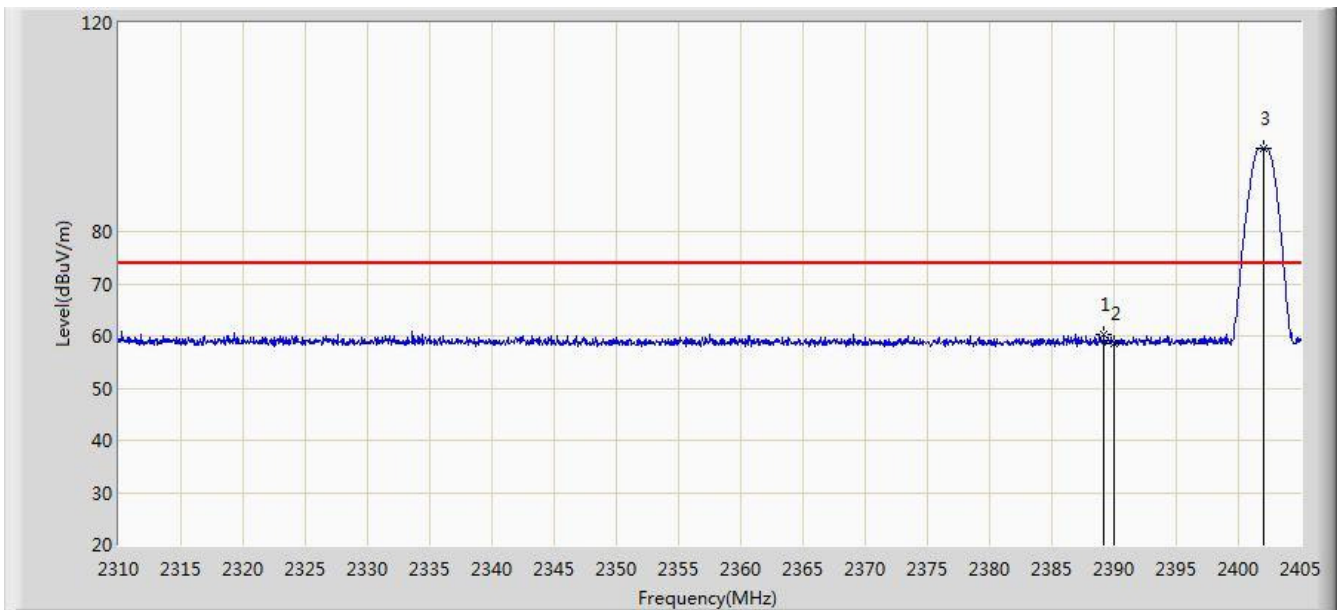

No	Flag	Mark	Frequency (MHz)	Measure Level (dBuV/m)	Reading Level (dBuV)	Over Limit (dB)	Limit (dBuV/m)	Factor (dB)	Type
1			2389.183	60.377	28.103	-13.623	74.000	32.274	PK
2			2390.000	58.649	26.371	-15.351	74.000	32.278	PK
3		*	2402.008	95.961	63.687	N/A	N/A	32.274	PK

Note: Measure Level (dB μ V/m) = Reading Level (dB μ V) + Factor (dB)

Factor (dB) = Cable Loss (dB) + Antenna Factor (dB/m)

Site: AC2	Time: 2016/12/24 - 14:47
Limit: FCC_Part15.209_RE(3m)	Engineer: Vince Yu
Probe: BBHA9120D_1-18GHz	Polarity: Horizontal
EUT: MID	Power: AC 120V/60Hz
Test Mode: Transmit by BLE at Channel 2402MHz	

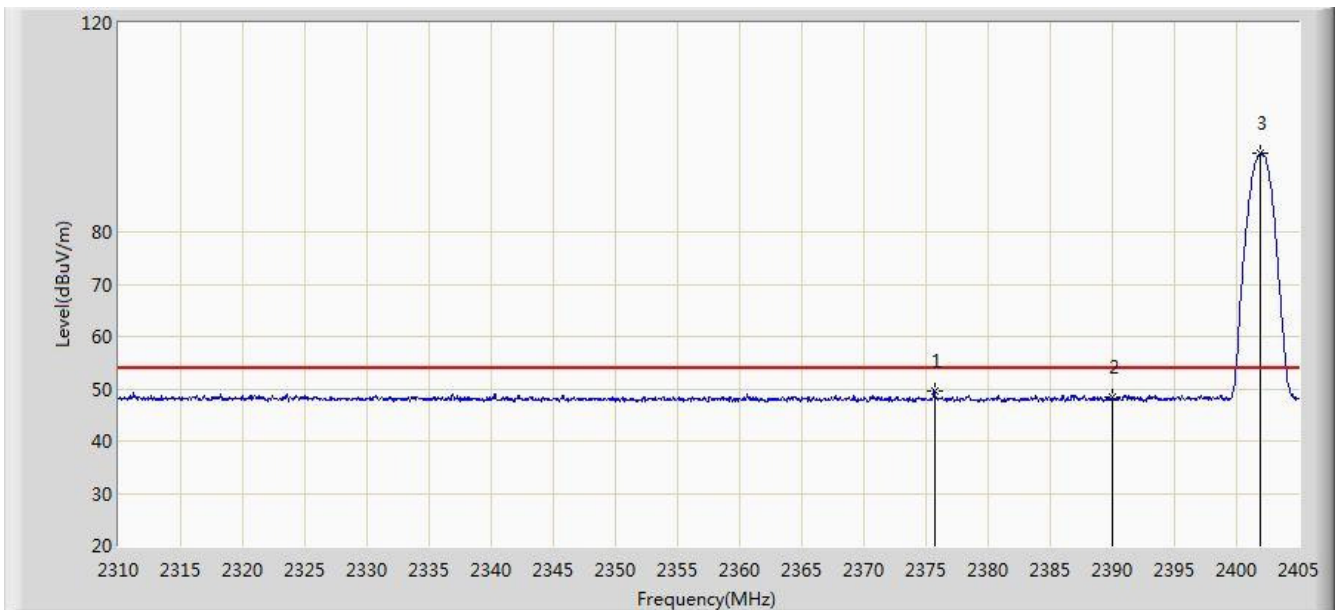

No	Flag	Mark	Frequency (MHz)	Measure Level (dBuV/m)	Reading Level (dBuV)	Over Limit (dB)	Limit (dBuV/m)	Factor (dB)	Type
1			2375.692	49.465	17.256	-4.535	54.000	32.209	AV
2			2390.000	48.429	16.151	-5.571	54.000	32.278	AV
3		*	2401.913	95.055	62.781	N/A	N/A	32.274	AV

Note: Measure Level (dB μ V/m) = Reading Level (dB μ V) + Factor (dB)

Factor (dB) = Cable Loss (dB) + Antenna Factor (dB/m)

Site: AC2	Time: 2016/12/24 - 14:50
Limit: FCC_Part15.209_RE(3m)	Engineer: Vince Yu
Probe: BBHA9120D_1-18GHz	Polarity: Vertical
EUT: MID	Power: AC 120V/60Hz
Test Mode: Transmit by BLE at Channel 2402MHz	

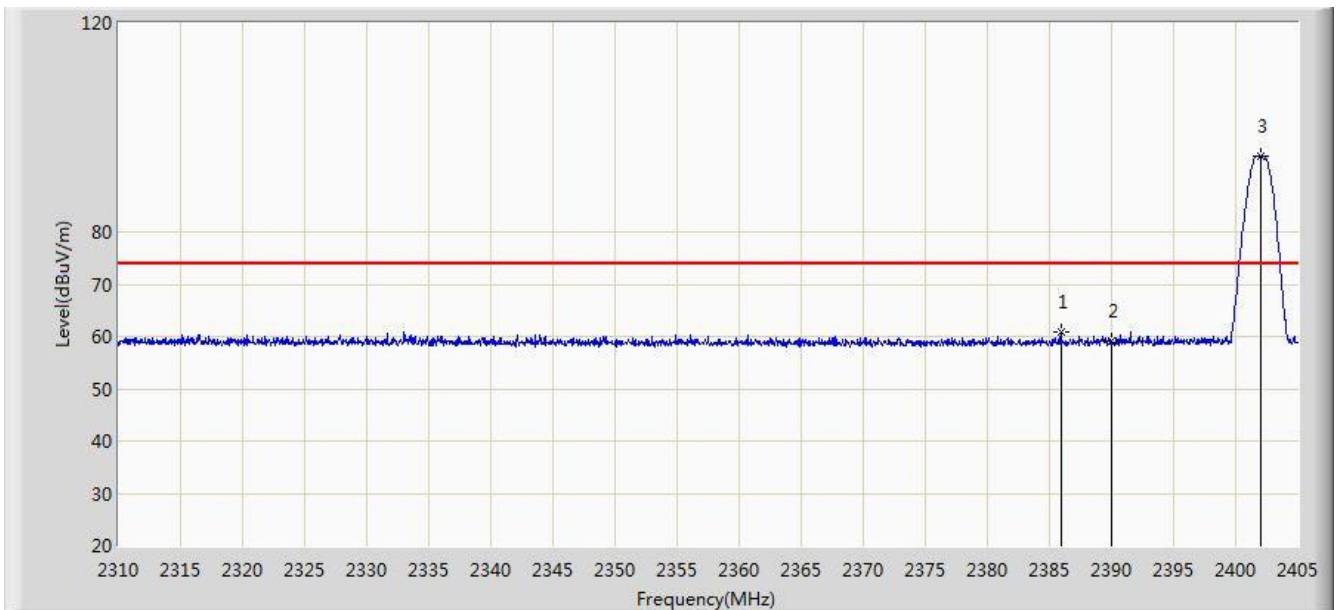

No	Flag	Mark	Frequency (MHz)	Measure Level (dBuV/m)	Reading Level (dBuV)	Over Limit (dB)	Limit (dBuV/m)	Factor (dB)	Type
1			2385.905	60.827	28.572	-13.173	74.000	32.255	PK
2			2390.000	59.101	26.823	-14.899	74.000	32.278	PK
3		*	2402.055	94.428	62.154	N/A	N/A	32.273	PK

Note: Measure Level (dB μ V/m) = Reading Level (dB μ V) + Factor (dB)

Factor (dB) = Cable Loss (dB) + Antenna Factor (dB/m)

Site: AC2	Time: 2016/12/24 - 14:53
Limit: FCC_Part15.209_RE(3m)	Engineer: Vince Yu
Probe: BBHA9120D_1-18GHz	Polarity: Vertical
EUT: MID	Power: AC 120V/60Hz
Test Mode: Transmit by BLE at Channel 2402MHz	

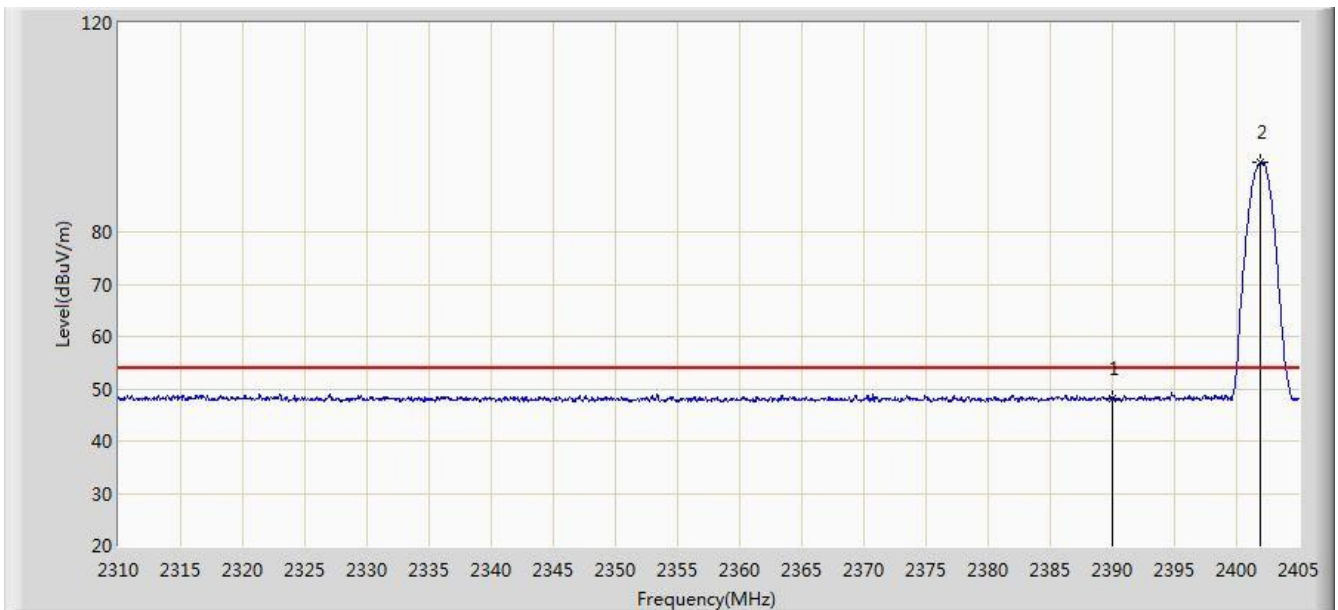

No	Flag	Mark	Frequency (MHz)	Measure Level (dBuV/m)	Reading Level (dBuV)	Over Limit (dB)	Limit (dBuV/m)	Factor (dB)	Type
1			2390.000	47.972	15.694	-6.028	54.000	32.278	AV
2		*	2401.865	93.217	60.943	N/A	N/A	32.274	AV

Note: Measure Level (dB μ V/m) = Reading Level (dB μ V) + Factor (dB)

Factor (dB) = Cable Loss (dB) + Antenna Factor (dB/m)

Site: AC2	Time: 2016/12/24 - 14:54
Limit: FCC_Part15.209_RE(3m)	Engineer: Vince Yu
Probe: BBHA9120D_1-18GHz	Polarity: Horizontal
EUT: MID	Power: AC 120V/60Hz
Test Mode: Transmit by BLE at Channel 2480MHz	

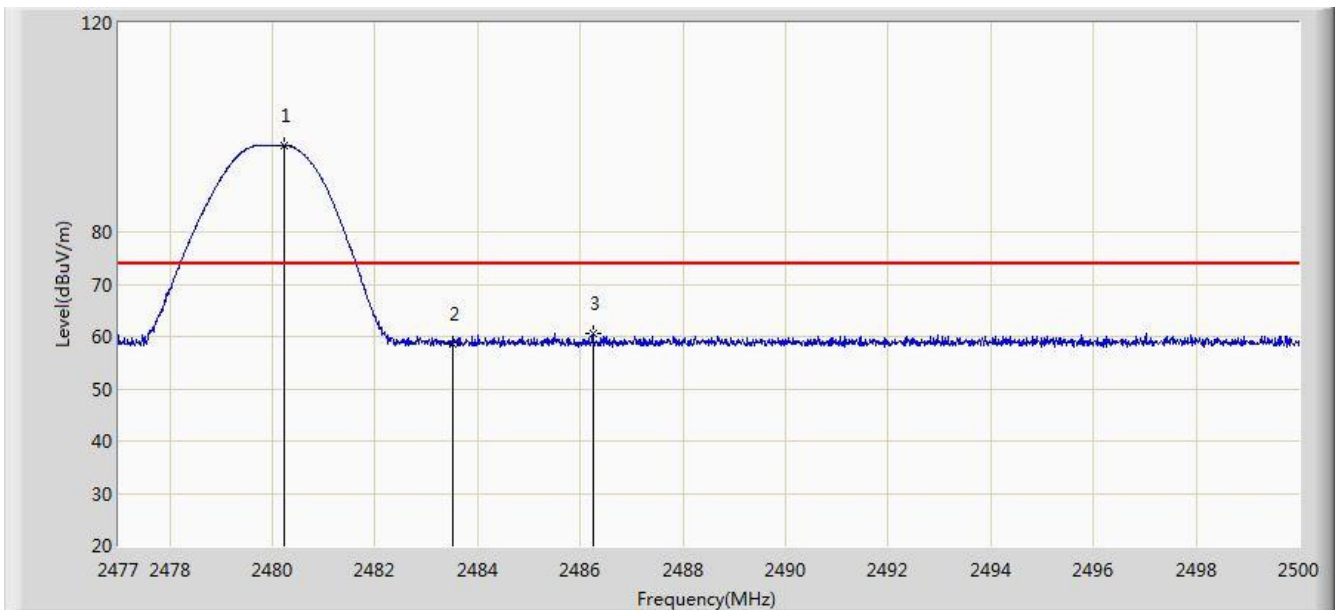

No	Flag	Mark	Frequency (MHz)	Measure Level (dBuV/m)	Reading Level (dBuV)	Over Limit (dB)	Limit (dBuV/m)	Factor (dB)	Type
1		*	2480.220	96.555	64.285	N/A	N/A	32.270	PK
2			2483.500	58.507	26.226	-15.493	74.000	32.282	PK
3			2486.246	60.606	28.315	-13.394	74.000	32.291	PK

Note: Measure Level (dB μ V/m) = Reading Level (dB μ V) + Factor (dB)

Factor (dB) = Cable Loss (dB) + Antenna Factor (dB/m)

Site: AC2	Time: 2016/12/24 - 15:00
Limit: FCC_Part15.209_RE(3m)	Engineer: Vince Yu
Probe: BBHA9120D_1-18GHz	Polarity: Horizontal
EUT: MID	Power: AC 120V/60Hz
Test Mode: Transmit by BLE at Channel 2480MHz	

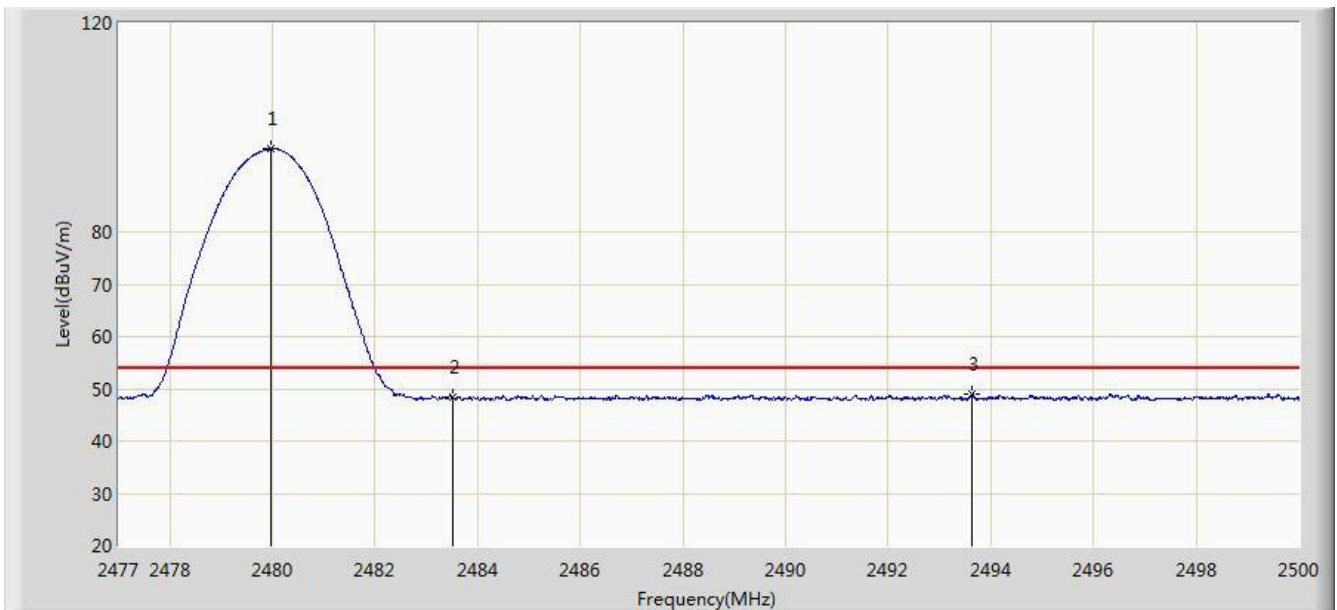

No	Flag	Mark	Frequency (MHz)	Measure Level (dBuV/m)	Reading Level (dBuV)	Over Limit (dB)	Limit (dBuV/m)	Factor (dB)	Type
1		*	2479.956	95.860	63.591	N/A	N/A	32.269	AV
2			2483.500	48.358	16.077	-5.642	54.000	32.282	AV
3			2493.640	48.967	16.651	-5.033	54.000	32.316	AV

Note: Measure Level (dB μ V/m) = Reading Level (dB μ V) + Factor (dB)

Factor (dB) = Cable Loss (dB) + Antenna Factor (dB/m)

Site: AC2	Time: 2016/12/24 - 15:00
Limit: FCC_Part15.209_RE(3m)	Engineer: Vince Yu
Probe: BBHA9120D_1-18GHz	Polarity: Vertical
EUT: MID	Power: AC 120V/60Hz
Test Mode: Transmit by BLE at Channel 2480MHz	

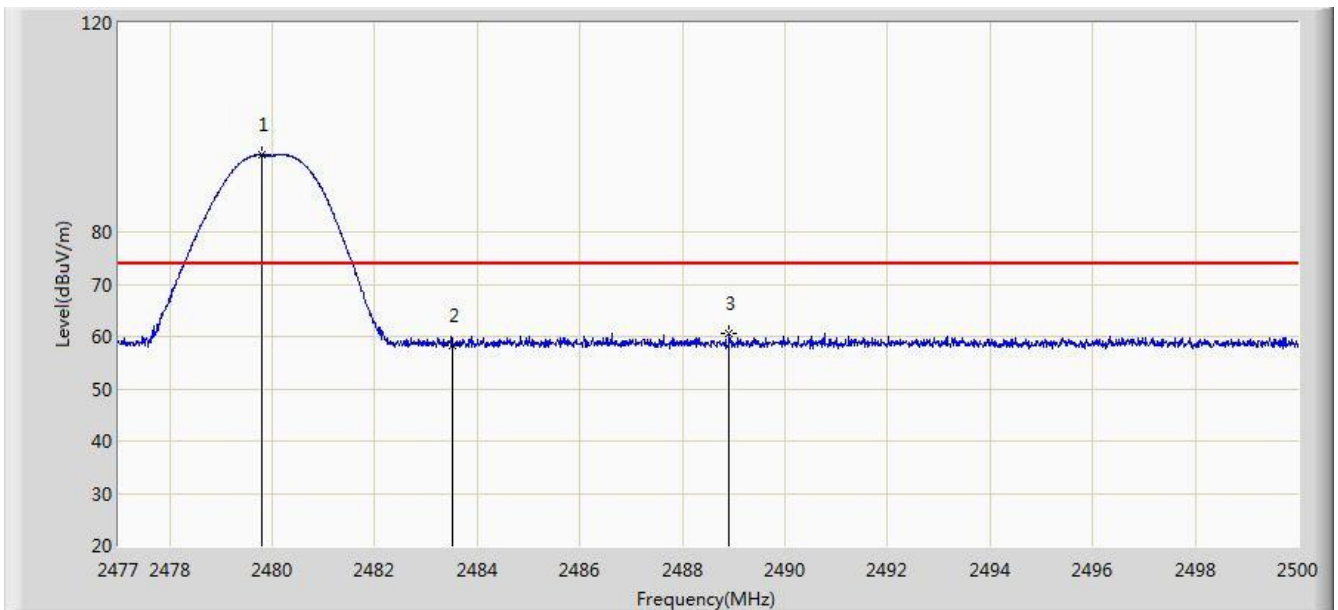

No	Flag	Mark	Frequency (MHz)	Measure Level (dBuV/m)	Reading Level (dBuV)	Over Limit (dB)	Limit (dBuV/m)	Factor (dB)	Type
1		*	2479.794	94.730	62.462	N/A	N/A	32.269	PK
2			2483.500	58.309	26.028	-15.691	74.000	32.282	PK
3			2488.914	60.618	28.318	-13.382	74.000	32.300	PK

Note: Measure Level (dB μ V/m) = Reading Level (dB μ V) + Factor (dB)

Factor (dB) = Cable Loss (dB) + Antenna Factor (dB/m)

Site: AC2	Time: 2016/12/24 - 15:02
Limit: FCC_Part15.209_RE(3m)	Engineer: Vince Yu
Probe: BBHA9120D_1-18GHz	Polarity: Vertical
EUT: MID	Power: AC 120V/60Hz
Test Mode: Transmit by BLE at Channel 2480MHz	

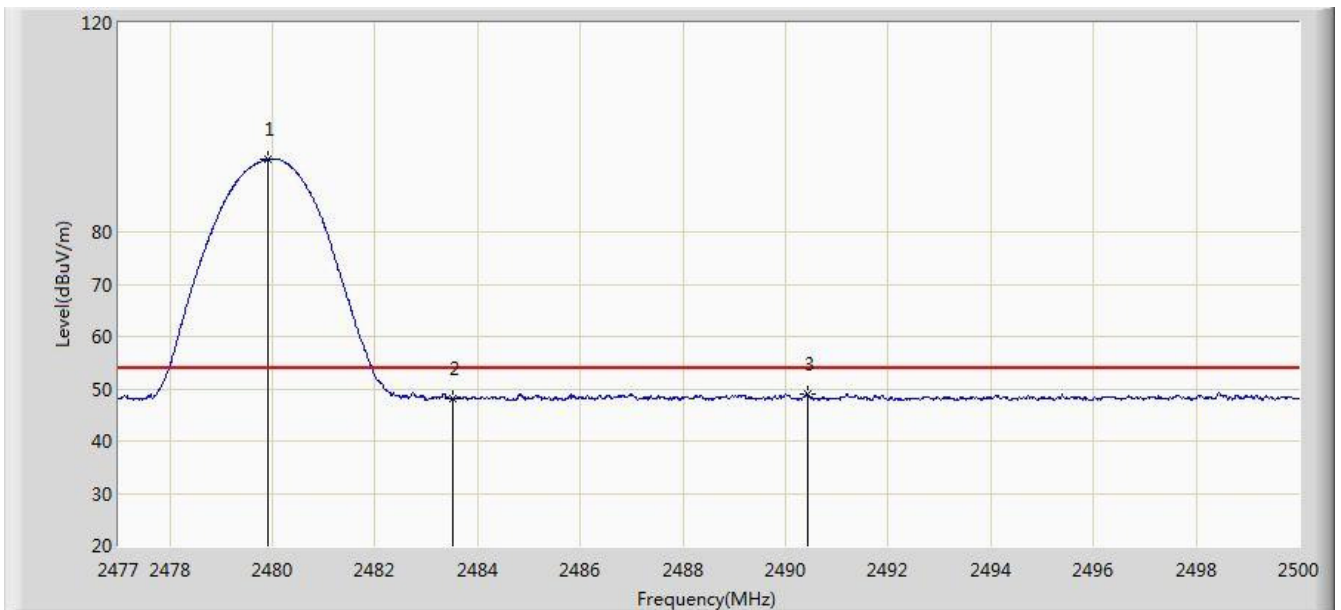

No	Flag	Mark	Frequency (MHz)	Measure Level (dBuV/m)	Reading Level (dBuV)	Over Limit (dB)	Limit (dBuV/m)	Factor (dB)	Type
1		*	2479.921	93.918	61.649	N/A	N/A	32.269	AV
2			2483.500	48.022	15.741	-5.978	54.000	32.282	AV
3			2490.432	48.962	16.657	-5.038	54.000	32.305	AV

Note: Measure Level (dB μ V/m) = Reading Level (dB μ V) + Factor (dB)

Factor (dB) = Cable Loss (dB) + Antenna Factor (dB/m)

7.8. AC Conducted Emissions Measurement

7.8.1. Test Limit

FCC Part 15 Subpart C Paragraph 15.207 Limits		
Frequency (MHz)	QP (dBuV)	AV (dBuV)
0.15 - 0.50	66 - 56	56 - 46
0.50 - 5.0	56	46
5.0 - 30	60	50

Note 1: The lower limit shall apply at the transition frequencies.

Note 2: The limit decreases linearly with the logarithm of the frequency in the range 0.15MHz to 0.5MHz.

7.8.2. Test Setup

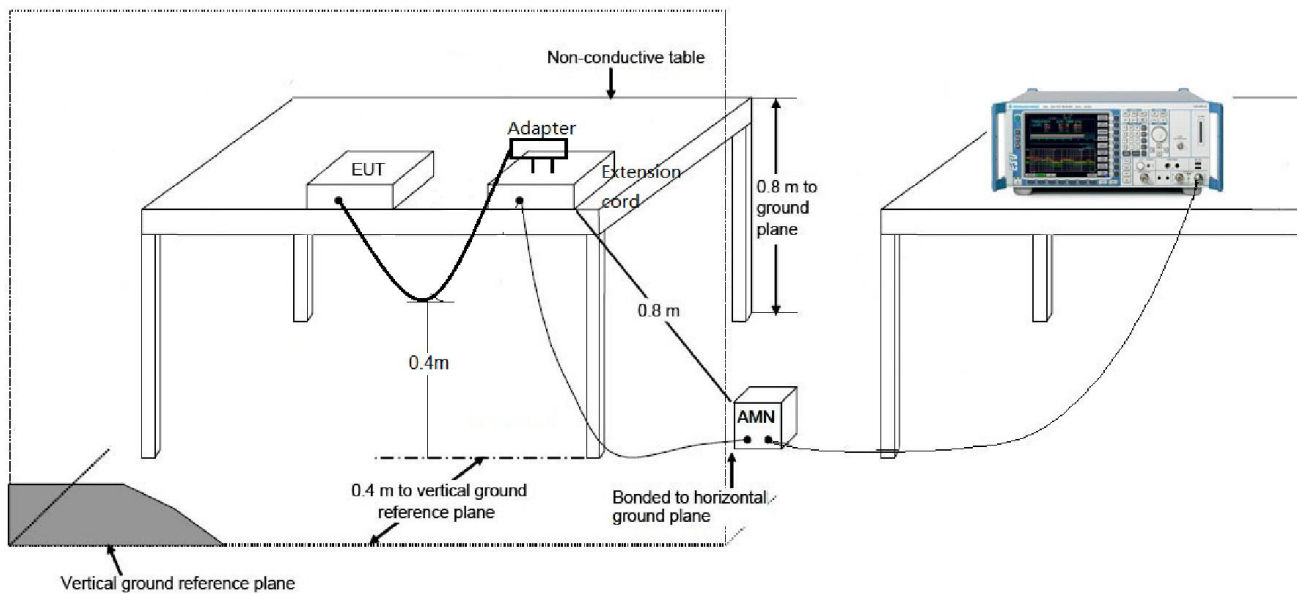

7.8.3. Test Result

Site: SR2	Time: 2017/03/23 - 13:50
Limit: FCC_Part15.207_CE_AC Power	Engineer: Bruce Wang
Probe: ENV216_101683_Filter On	Polarity: Line
EUT: MID	Power: AC 120V/60Hz
Worst Case Mode: Transmit by BLE at channel 2402MHz	

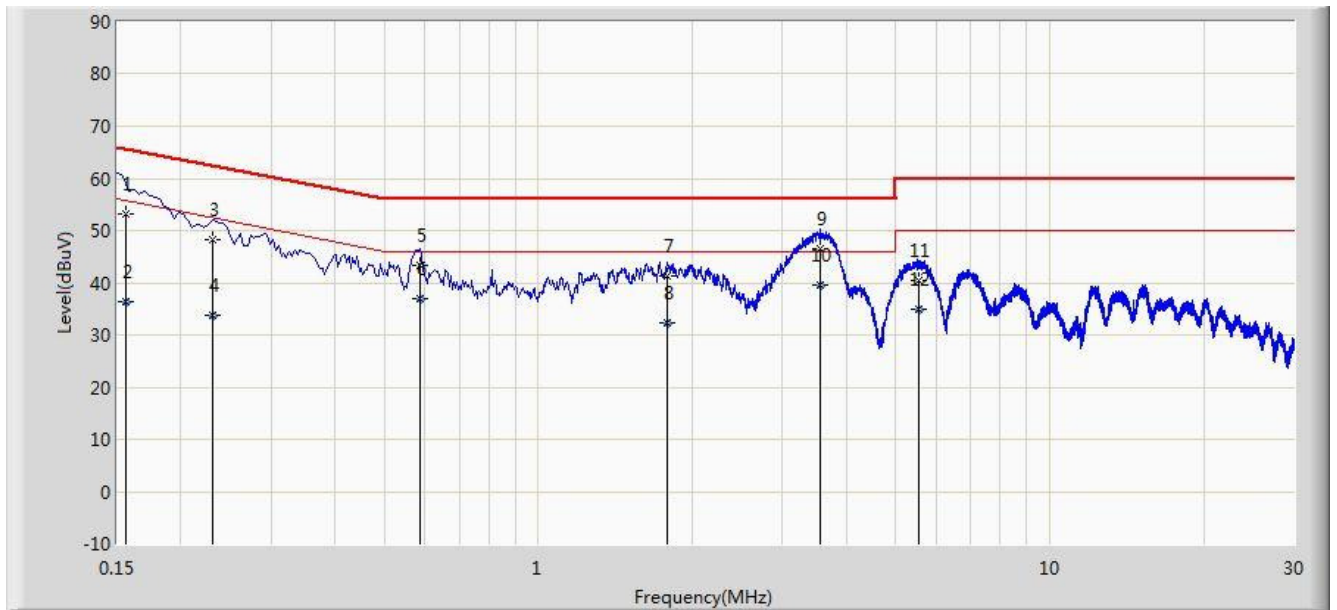

No	Flag	Mark	Frequency (MHz)	Measure Level (dBuV)	Reading Level (dBuV)	Over Limit (dB)	Limit (dBuV)	Factor (dB)	Type
1			0.156	53.304	42.810	-12.355	65.659	10.494	QP
2			0.156	36.267	25.773	-19.391	55.659	10.494	AV
3			0.230	48.128	38.181	-14.321	62.450	9.947	QP
4			0.230	33.760	23.813	-18.690	52.450	9.947	AV
5			0.586	43.265	33.143	-12.735	56.000	10.122	QP
6			0.586	36.956	26.834	-9.044	46.000	10.122	AV
7			1.786	41.254	31.375	-14.746	56.000	9.879	QP
8			1.786	32.385	22.506	-13.615	46.000	9.879	AV
9			3.558	46.398	36.484	-9.602	56.000	9.913	QP
10		*	3.558	39.703	29.789	-6.297	46.000	9.913	AV
11			5.530	40.307	30.235	-19.693	60.000	10.072	QP
12			5.530	34.975	24.903	-15.025	50.000	10.072	AV

Note: Measure Level (dBμV) = Reading Level (dBμV) + Factor (dB)

Factor (dB) = Cable Loss (dB) + LISN Factor (dB)

Site: SR2	Time: 2017/03/23 - 13:57
Limit: FCC_Part15.207_CE_AC Power	Engineer: Bruce Wang
Probe: ENV216_101683_Filter On	Polarity: Neutral
EUT: MID	Power: AC 120V/60Hz
Worst Case Mode: Transmit by BLE at channel 2402MHz	

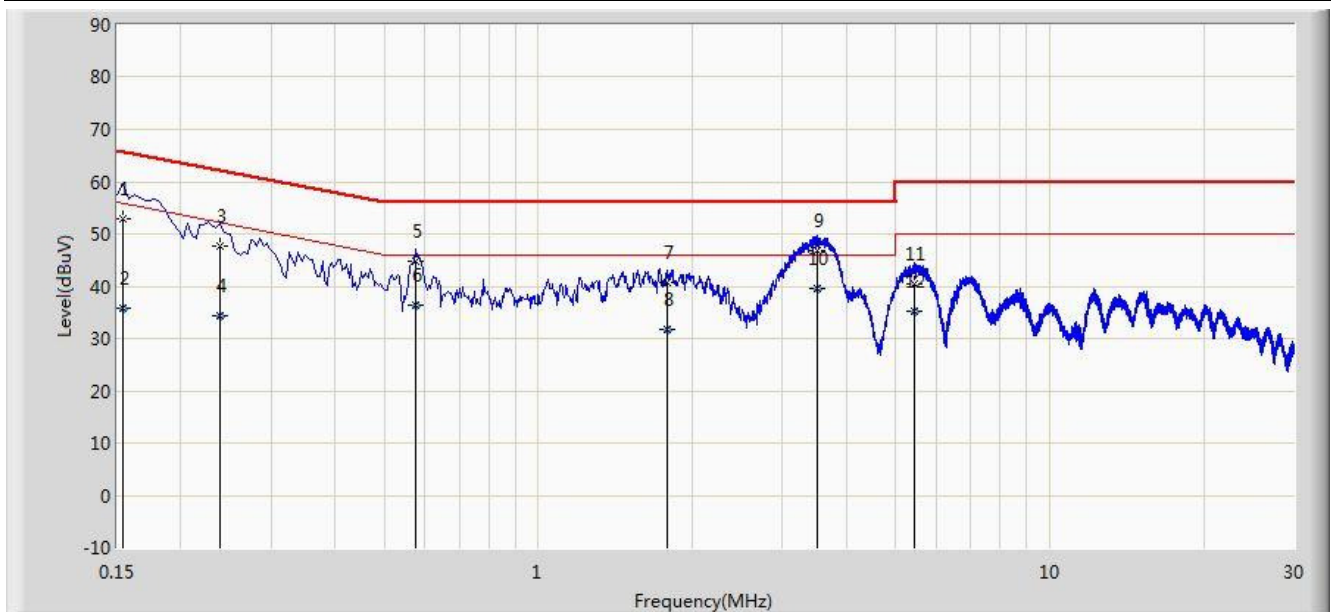

No	Flag	Mark	Frequency (MHz)	Measure Level (dBuV)	Reading Level (dBuV)	Over Limit (dB)	Limit (dBuV)	Factor (dB)	Type
1			0.154	52.976	42.260	-12.805	65.781	10.716	QP
2			0.154	35.719	25.003	-20.063	55.781	10.716	AV
3			0.238	47.778	37.786	-14.388	62.166	9.992	QP
4			0.238	34.474	24.482	-17.692	52.166	9.992	AV
5			0.574	44.642	34.497	-11.358	56.000	10.145	QP
6			0.574	36.334	26.189	-9.666	46.000	10.145	AV
7			1.786	40.825	30.945	-15.175	56.000	9.881	QP
8			1.786	31.729	21.849	-14.271	46.000	9.881	AV
9			3.510	46.887	36.972	-9.113	56.000	9.915	QP
10		*	3.510	39.645	29.730	-6.355	46.000	9.915	AV
11			5.430	40.474	30.391	-19.526	60.000	10.083	QP
12			5.430	35.301	25.218	-14.699	50.000	10.083	AV

Note: Measure Level (dBμV) = Reading Level (dBμV) + Factor (dB)

Factor (dB) = Cable Loss (dB) + LISN Factor (dB)

8. CONCLUSION

The data collected relate only the item(s) tested and show that the **MID** is in compliance with Part 15C of the FCC Rules.

————— The End —————