

Conducted Band Edge

LTE Band 13 / 10MHz / QPSK

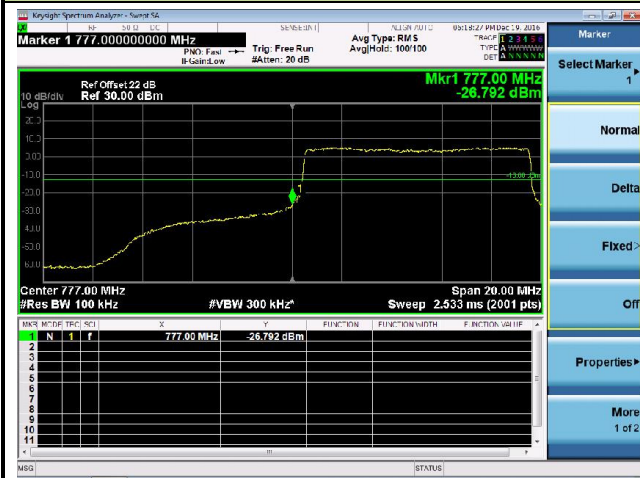

LTE Band 13 / 10MHz / 16-QAM

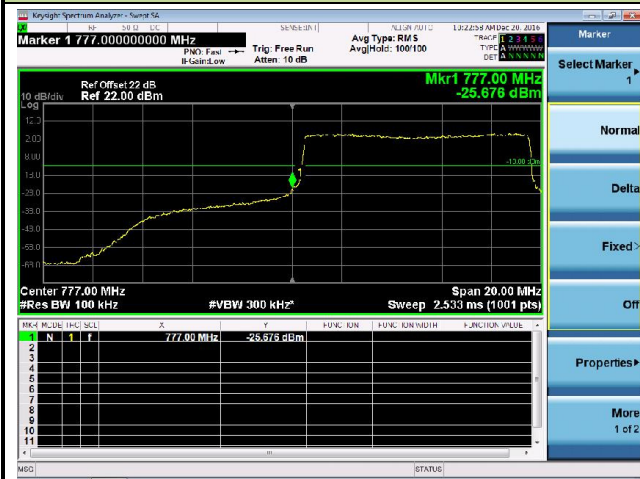

Conducted Band Edge

LTE Band 17 / 10MHz / QPSK

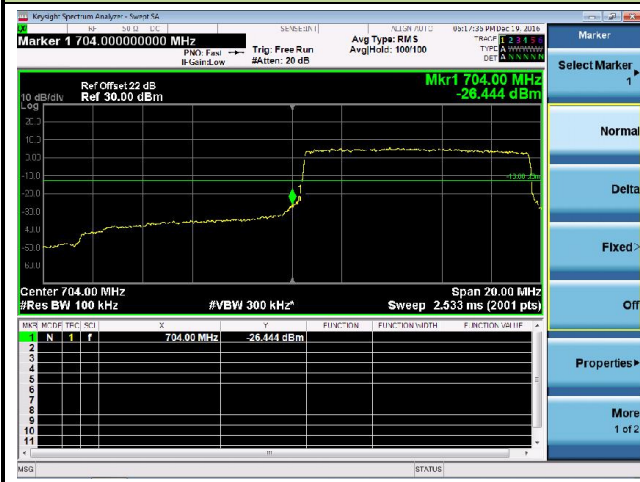

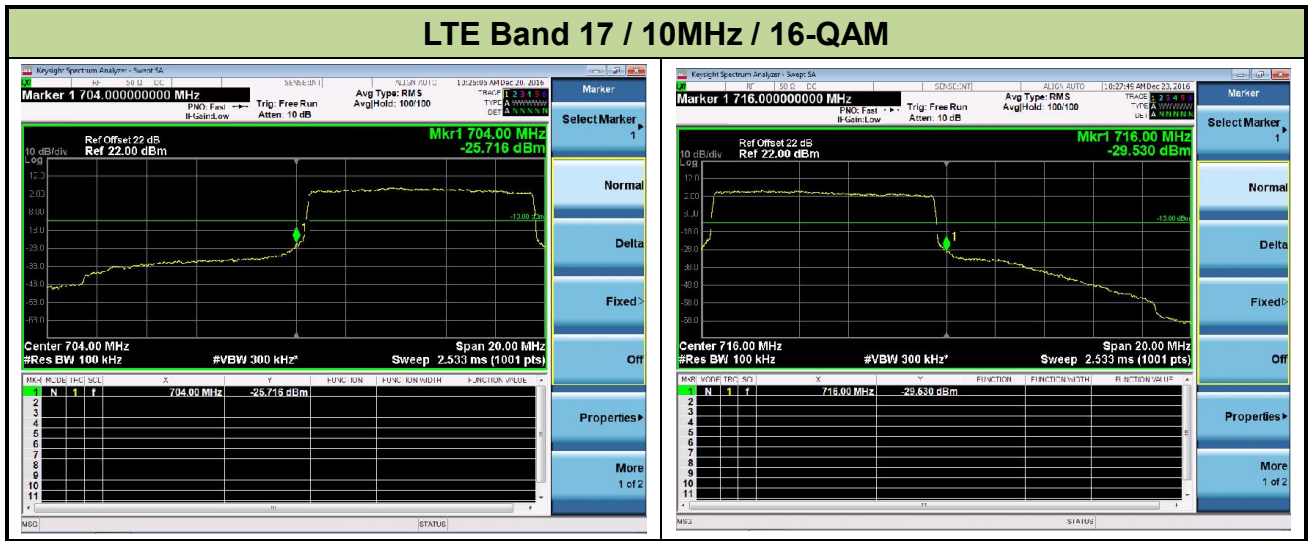

7.4. Spurious and Harmonic Emissions at Antenna Terminal

7.4.1. Test Limit

The power of any emission outside of the authorized operating frequency ranges must be attenuated below the transmitting power (P) by a factor of at least $43 + 10 \cdot \log(P)$ dB.

7.4.2. Test Procedure Used

KDB 971168 D01v02r02 – Section 6.0 & ANSI/TIA-603-D-2010

7.4.3. Test Setting

In the 1MHz bands immediately outside and adjacent to the frequency block a resolution bandwidth of at least one percent of the emission bandwidth of the fundamental emission of the transmitter may be employed to measure the out of band Emissions.

7.4.4. Test Setup

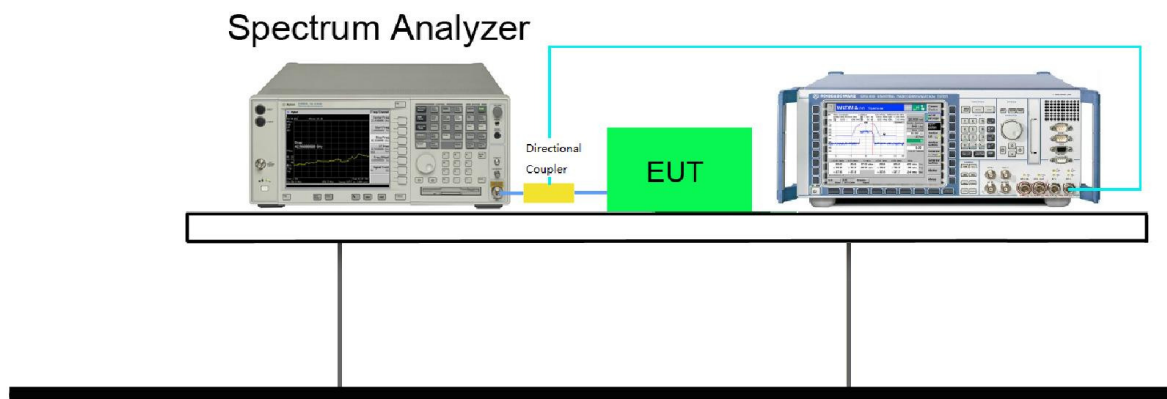

7.4.5. Test Result

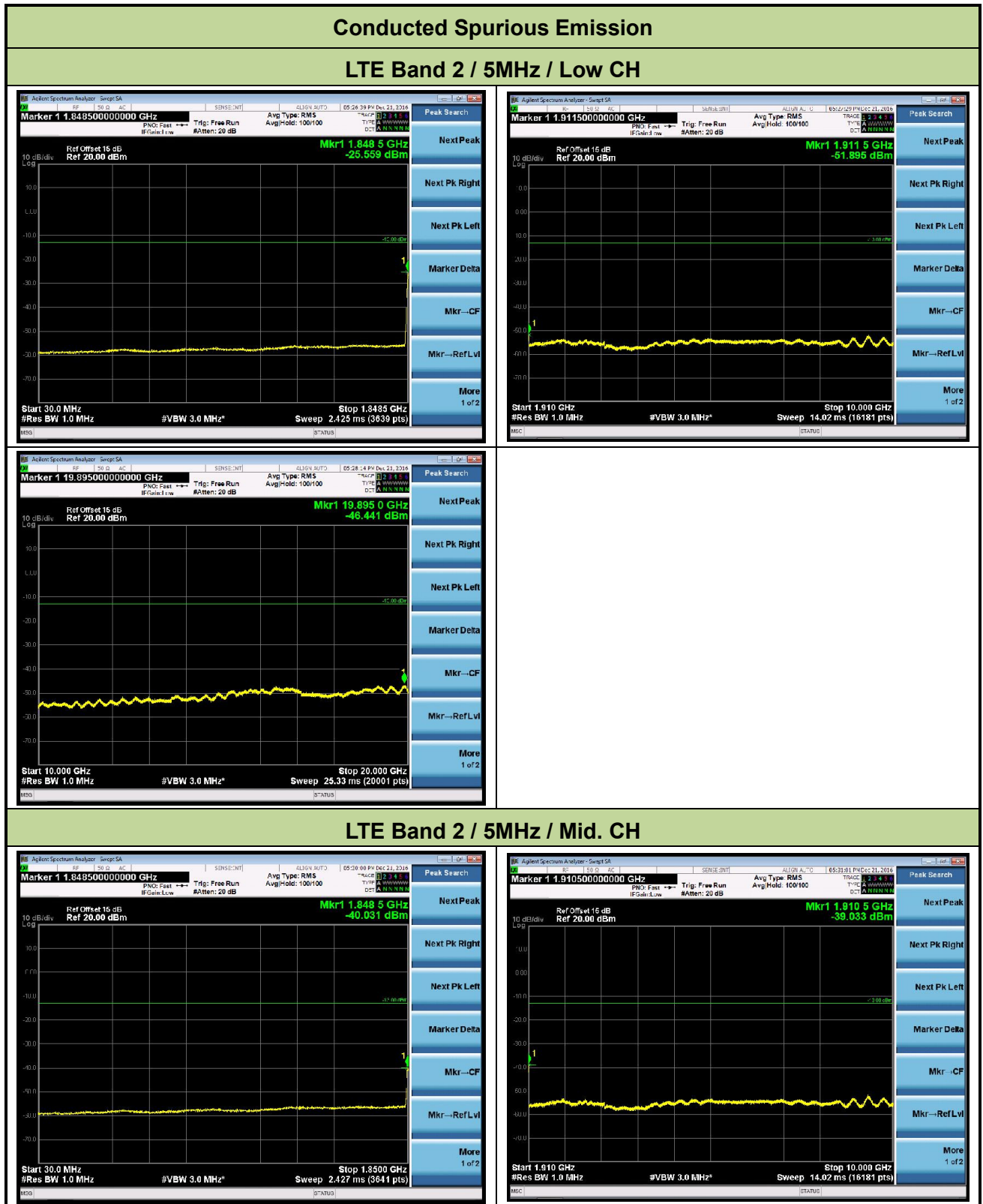



Peak Search

Next Peak

Next Pk Right

Next Pk Left

Marker Delta

Mkr--CF

Mkr--RefLvl

More
1 of 2

LTE Band 2 / 5MHz / High. CH

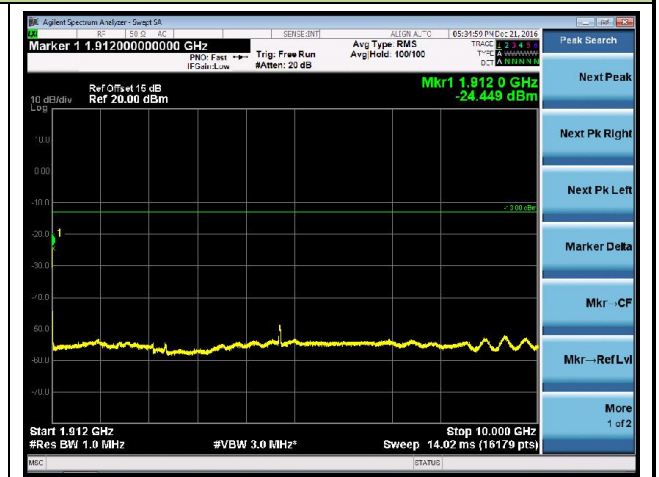
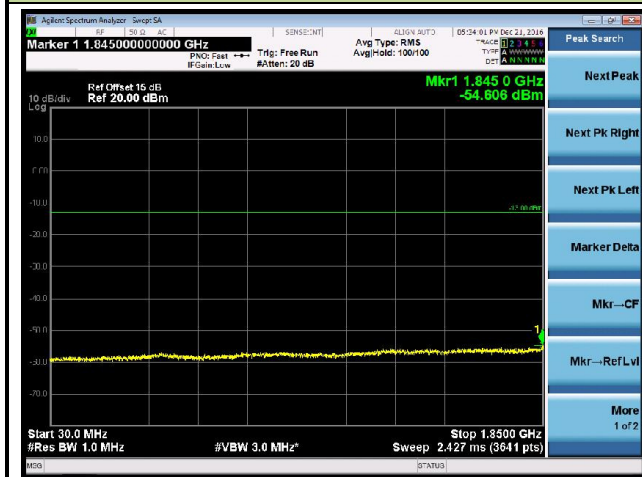

Peak Search

Next Peak

Next Pk Right

Next Pk Left

Marker Delta

Mkr--CF

Mkr--RefLvl

More
1 of 2

Conducted Spurious Emission

LTE Band 4 / 3MHz / Low CH



LTE Band 4 / 3MHz / Mid. CH

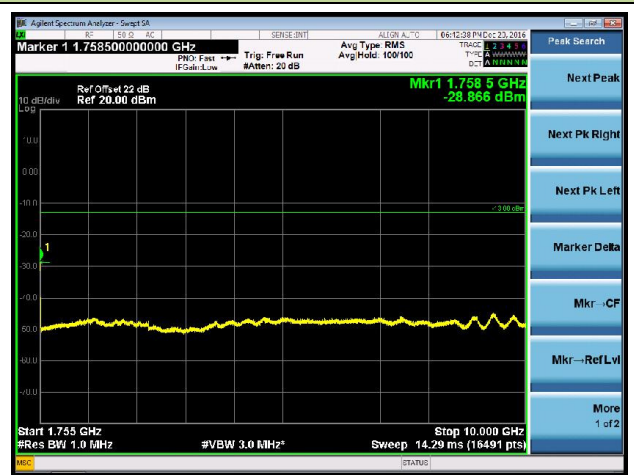
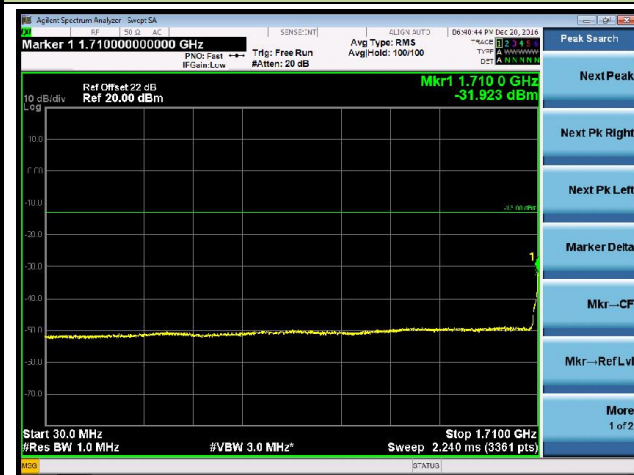

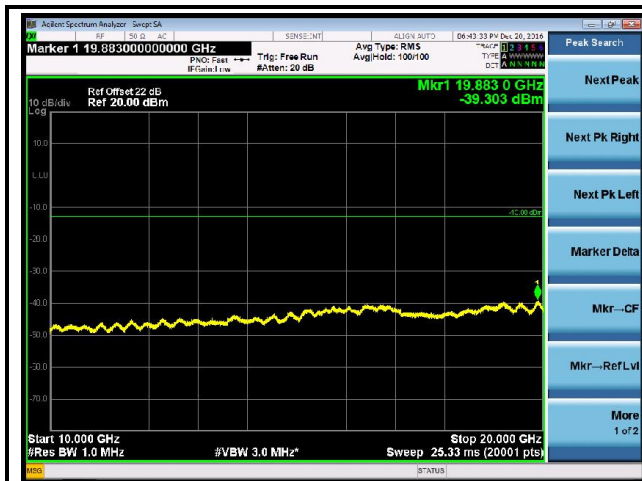

Peak Search

Next Peak

Next Pk Right

Next Pk Left

Marker Delta

Mkr--CF

Mkr--RefLvl

More
1 of 2

LTE Band 4 / 3MHz / High. CH

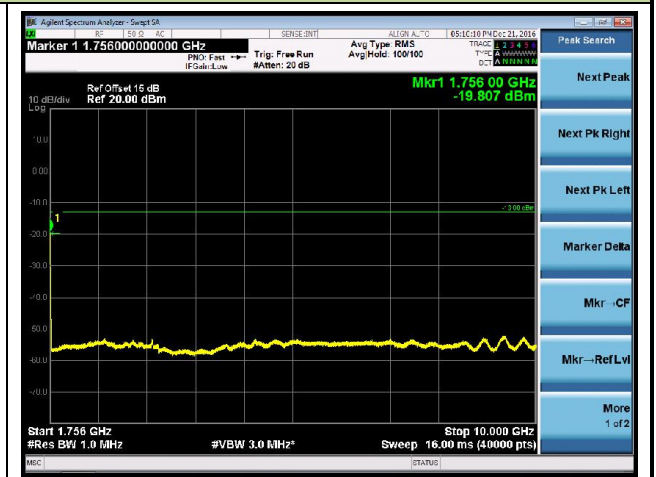
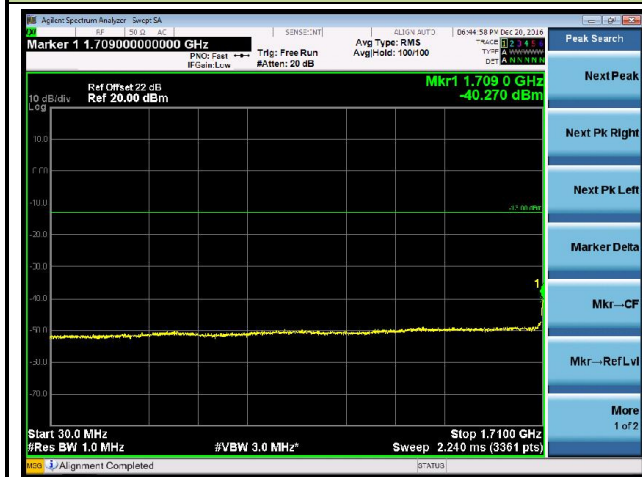

Peak Search

Next Peak

Next Pk Right

Next Pk Left

Marker Delta

Mkr--CF

Mkr--RefLvl

More
1 of 2

Conducted Spurious Emission

LTE Band 5 / 3MHz / Low CH

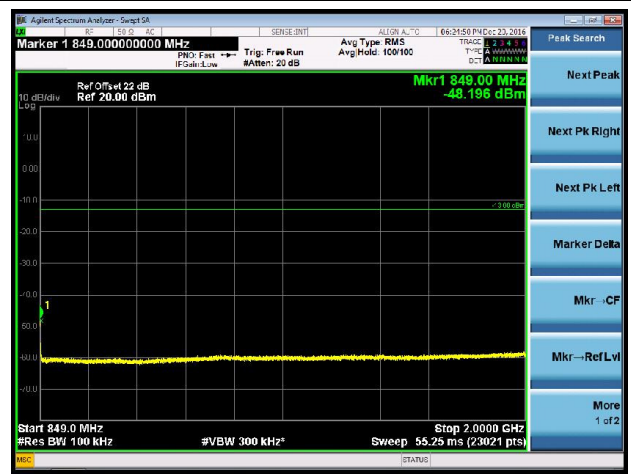

LTE Band 5 / 3MHz / Mid. CH

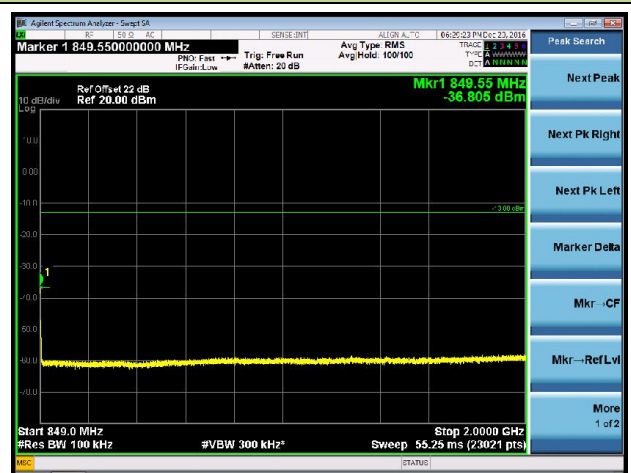
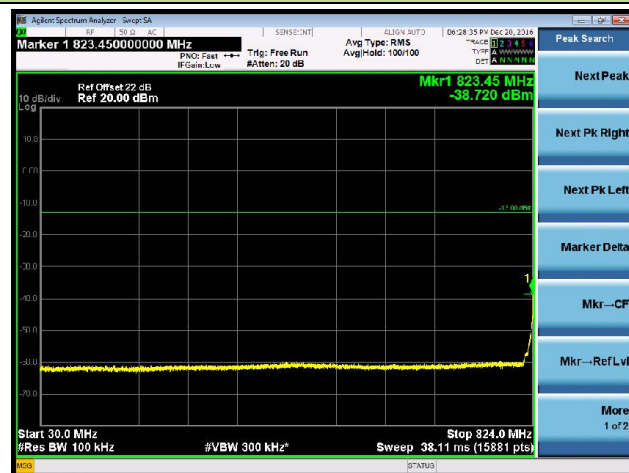

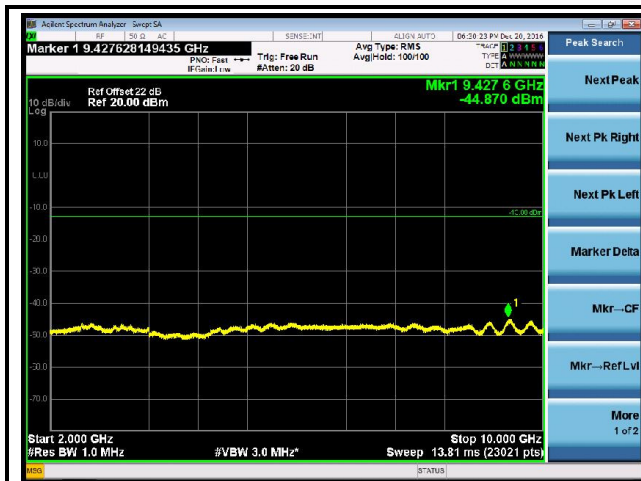

Peak Search

Next Peak

Next Pk Right

Next Pk Left

Marker Delta

Mkr--CF

Mkr--RefLvl

More 1 of 2

LTE Band 5 / 3MHz / High. CH

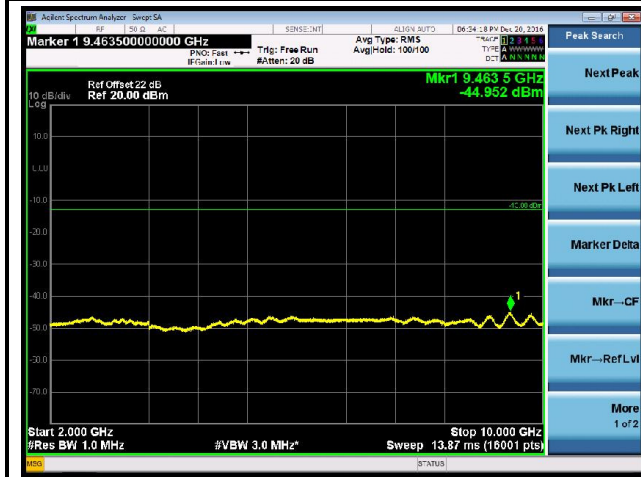
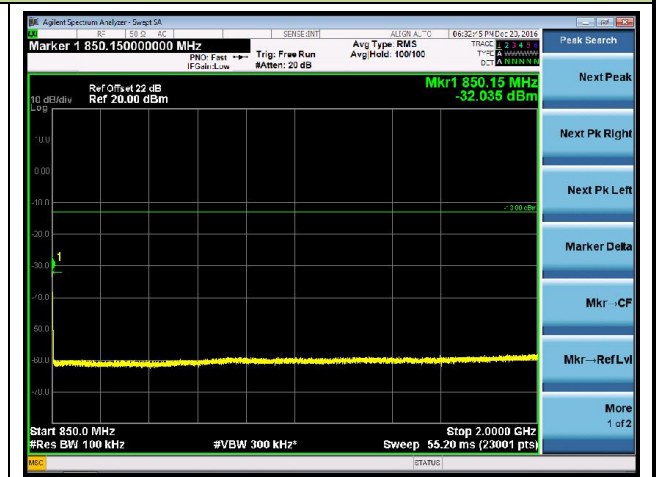
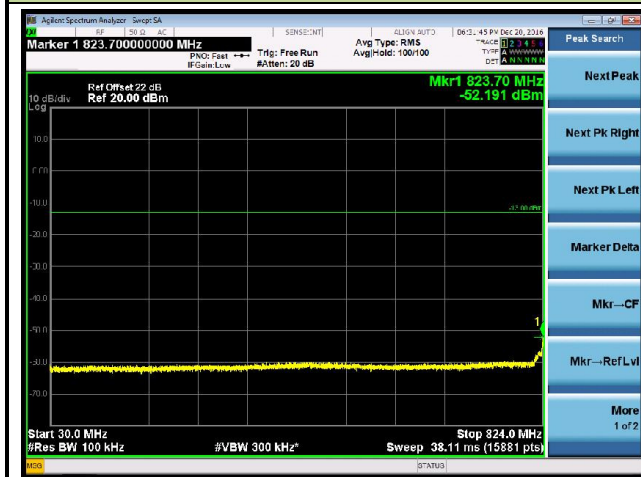

Peak Search

Next Peak

Next Pk Right

Next Pk Left

Marker Delta

Mkr--CF

Mkr--RefLvl

More 1 of 2

Conducted Spurious Emission

LTE Band 13 / 10MHz / Mid CH

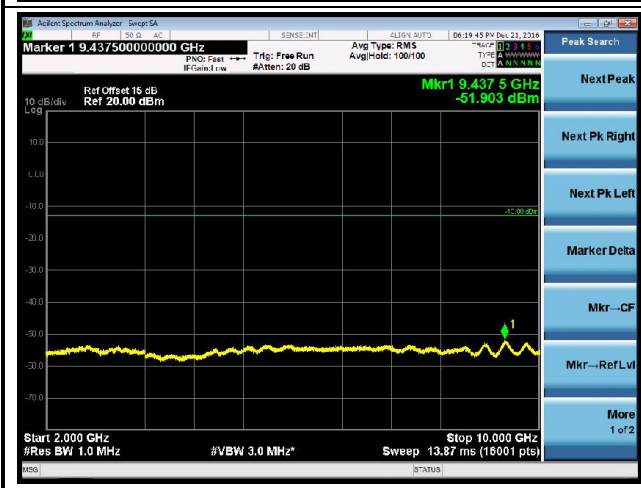
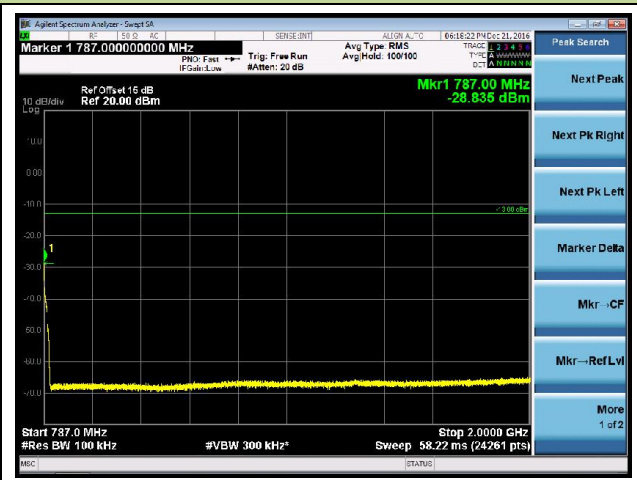
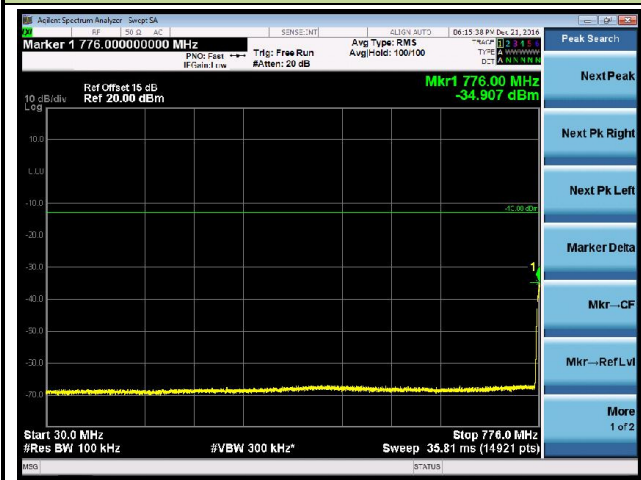

Conducted Spurious Emission

LTE Band 17 / 5MHz / Low CH

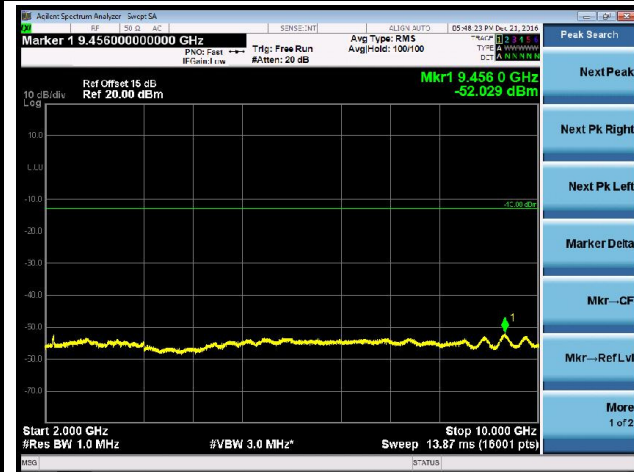
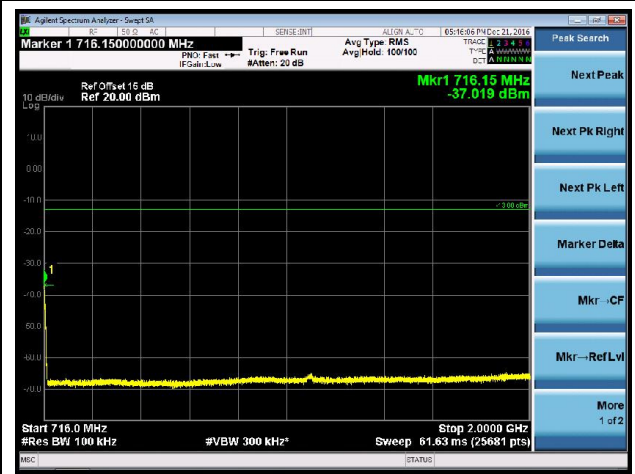
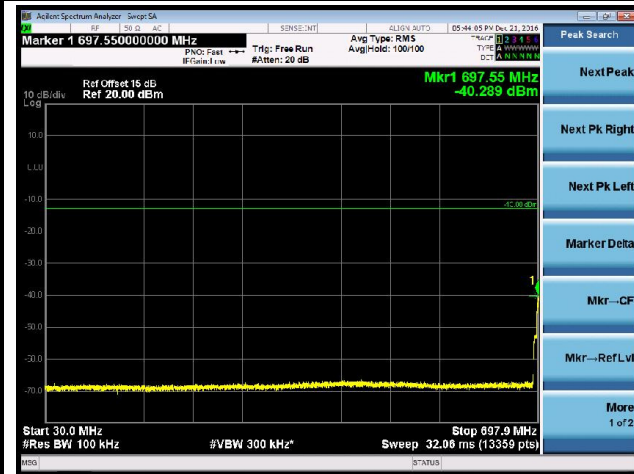

LTE Band 17 / 5MHz / Mid. CH

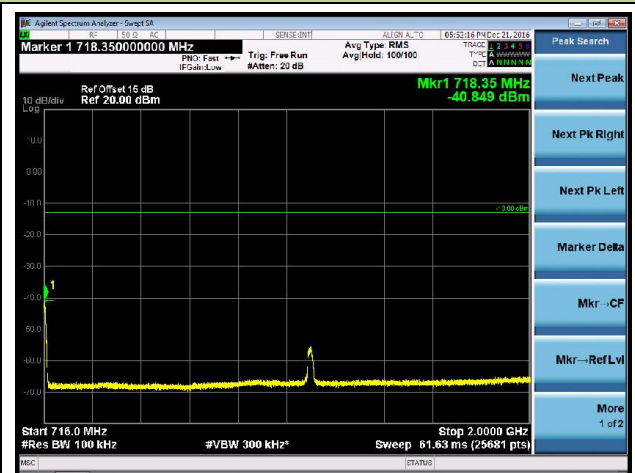
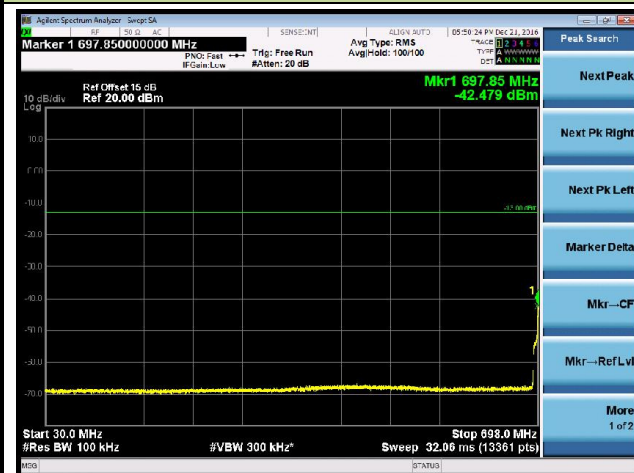

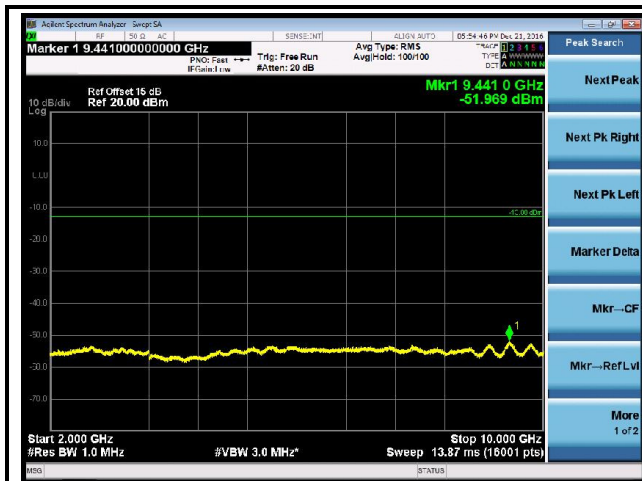

Peak Search

Next Peak

Next Pk Right

Next Pk Left

Marker Delta

Mkr--CF

Mkr--RefLvl

More
1 of 2

LTE Band 17 / 5MHz / High. CH

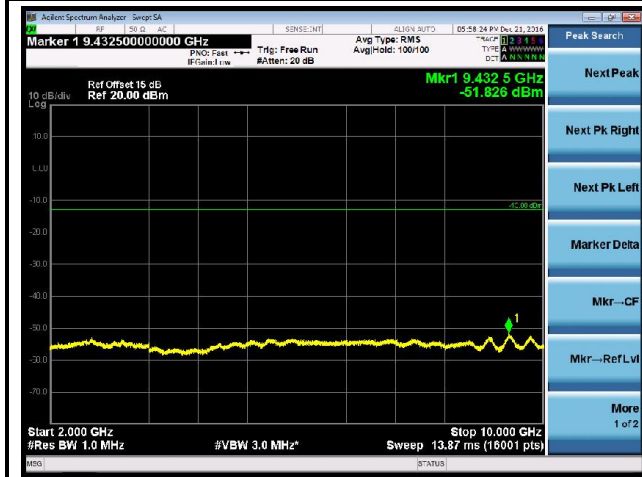
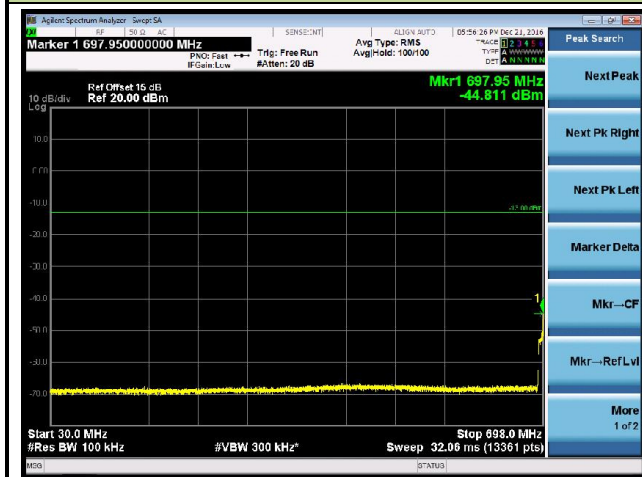

Peak Search

Next Peak

Next Pk Right

Next Pk Left

Marker Delta

Mkr--CF

Mkr--RefLvl

More
1 of 2

7.5. Peak-Average Ratio

7.5.1. Test Limit

The transmitter's peak-to-average power ratio (PAPR) shall not exceed 13 dB for more than 0.1% of the time using a signal corresponding to the highest PAPR during periods of continuous transmission.

7.5.2. Test Procedure

KDB 971168 D01v02r02 - Section 5.7 & ANSI/TIA-603-D-2010

7.5.3. Test Setup

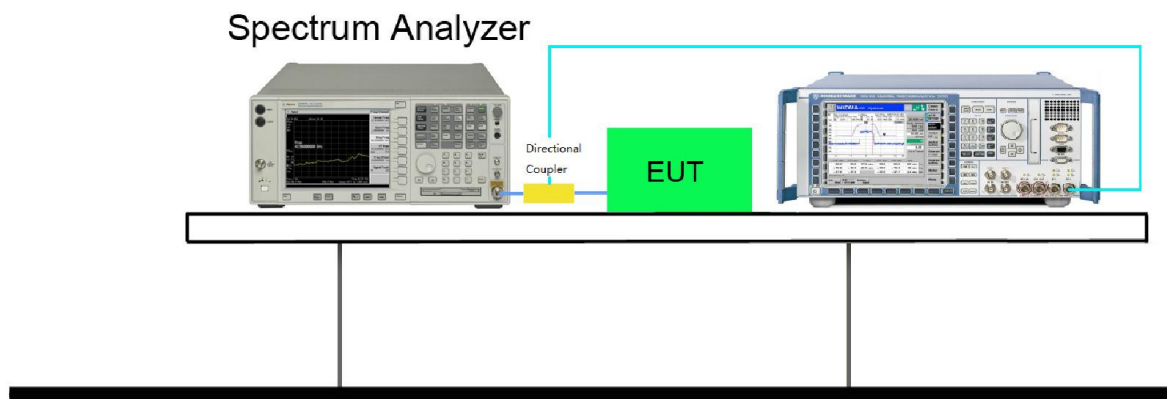

7.5.4. Test Result

LTE Band 2 / 20MHz					
Mod.	QPSK		16-QAM		Limit: 13dB
RB Size	1RB	Full RB	1RB	Full RB	Result
Low CH	3.94	5.26	4.85	5.90	Pass
Mid. CH	3.10	5.09	4.37	5.81	Pass
High CH	3.98	5.11	4.93	5.82	Pass

LTE Band 4 / 20MHz					
Mod.	QPSK		16-QAM		Limit: 13dB
RB Size	1RB	Full RB	1RB	Full RB	Result
Low CH	4.22	5.49	5.20	6.17	Pass
Mid. CH	4.26	5.31	5.36	6.11	Pass
High CH	3.91	5.35	4.89	6.09	Pass

LTE Band 5 / 10MHz					
Mod.	QPSK		16-QAM		Limit: 13dB
RB Size	1RB	Full RB	1RB	Full RB	Result
Low CH	4.29	5.29	4.92	6.05	Pass
Mid. CH	4.53	5.26	5.38	6.10	Pass
High CH	4.45	5.15	5.24	5.91	Pass

LTE Band 13 / 10MHz					
Mod.	QPSK		16-QAM		Limit: 13dB
RB Size	1RB	Full RB	1RB	Full RB	Result
Mid. CH	4.22	5.25	5.22	6.00	Pass

LTE Band 17 / 10MHz					
Mod.	QPSK		16-QAM		Limit: 13dB
RB Size	1RB	Full RB	1RB	Full RB	Result
Low CH	4.55	5.22	5.36	6.09	Pass
Mid. CH	4.52	5.24	5.45	6.08	Pass
High CH	4.57	5.33	5.59	6.11	Pass

LTE Band 2 / 20MHz / QPSK

Low CH / 1RB

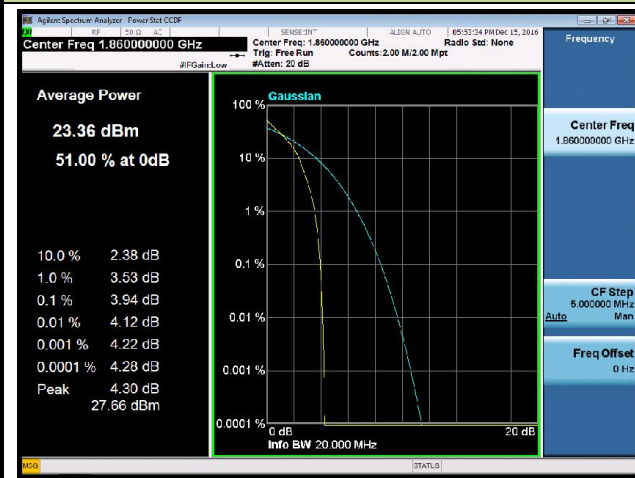

Low CH Full RB

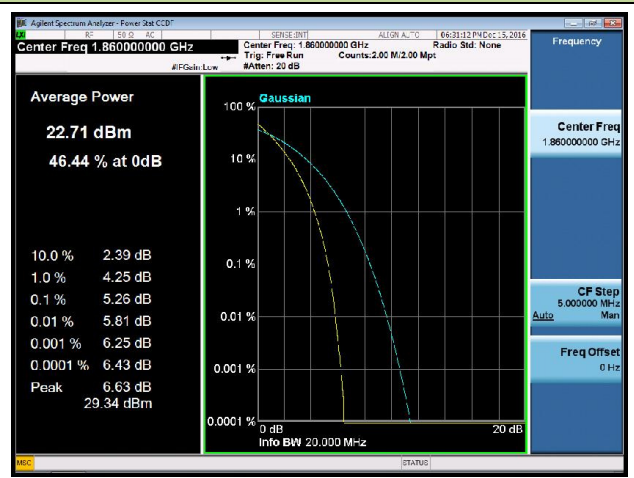

Mid CH / 1RB

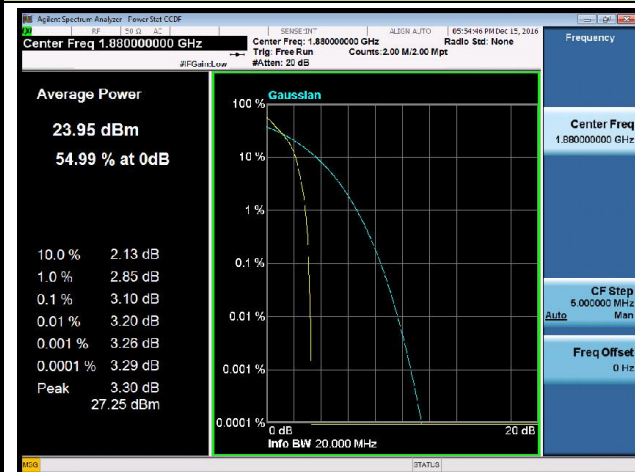

Mid CH Full RB

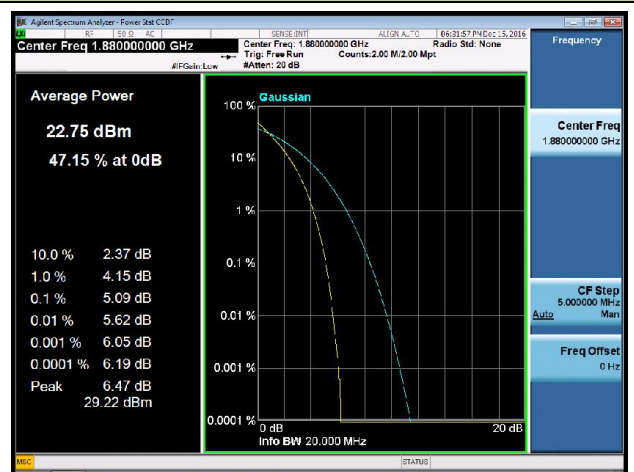

High CH / 1RB

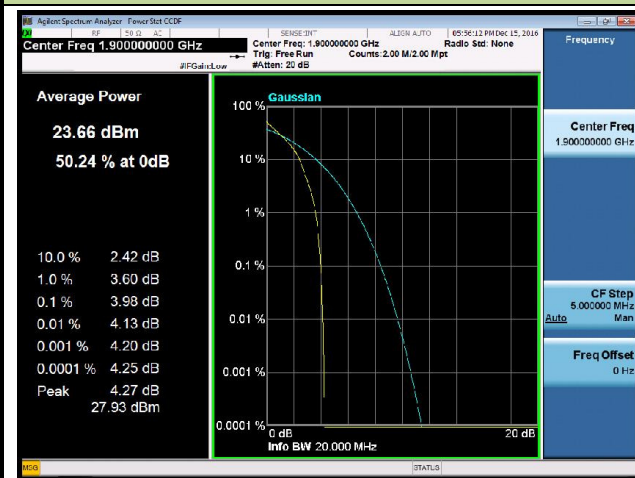

High CH Full RB

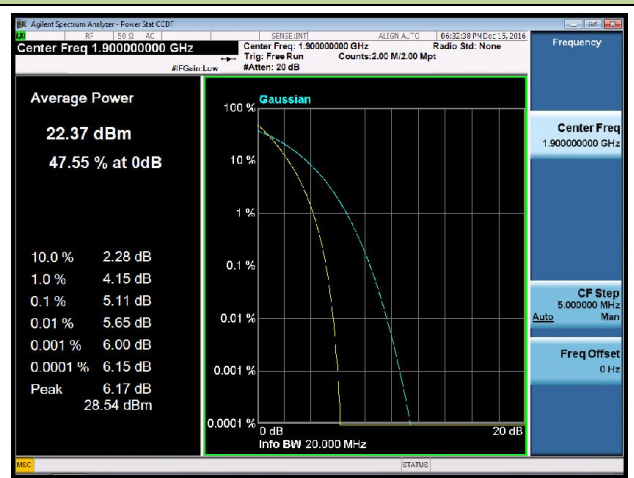

LTE Band 2 / 20MHz / 16-QAM

Low CH / 1RB

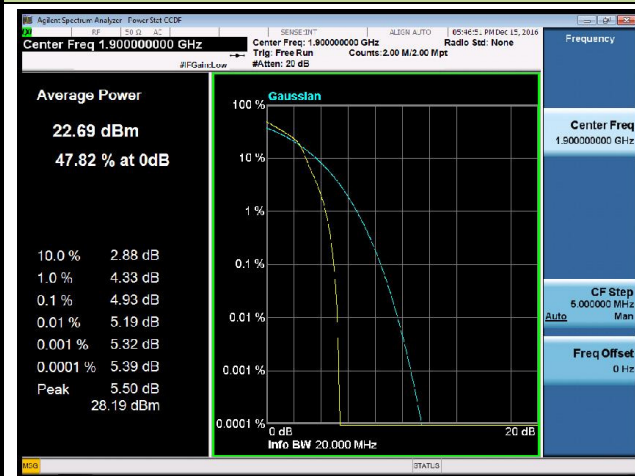

Low CH Full RB

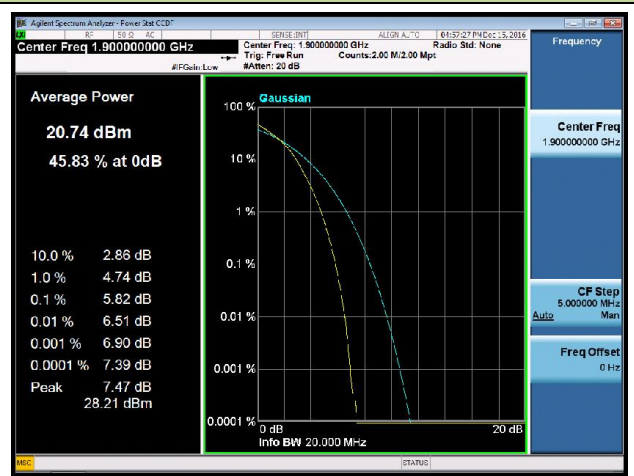

Mid CH / 1RB

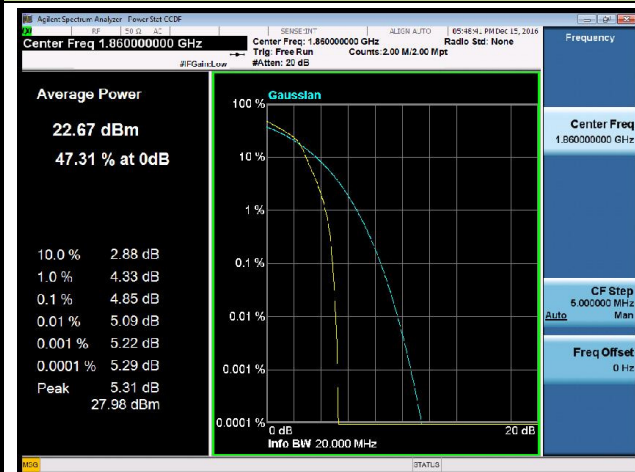

Mid CH Full RB

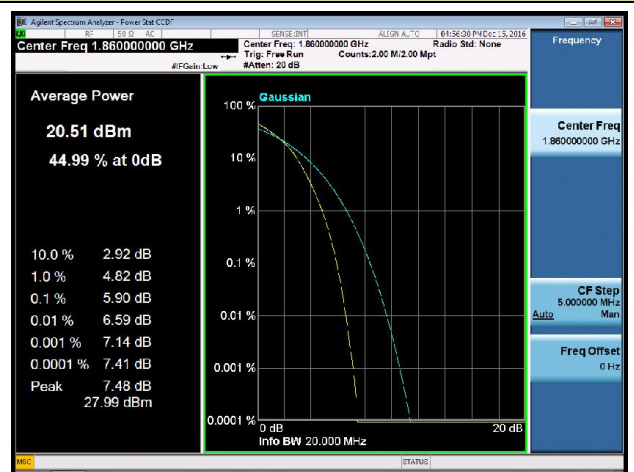

High CH / 1RB

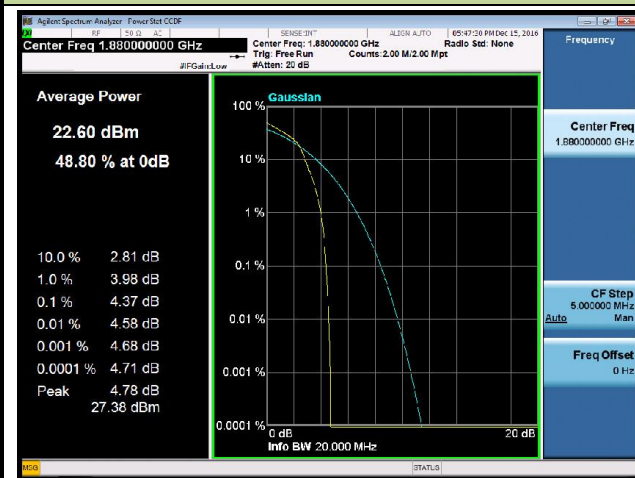

High CH Full RB

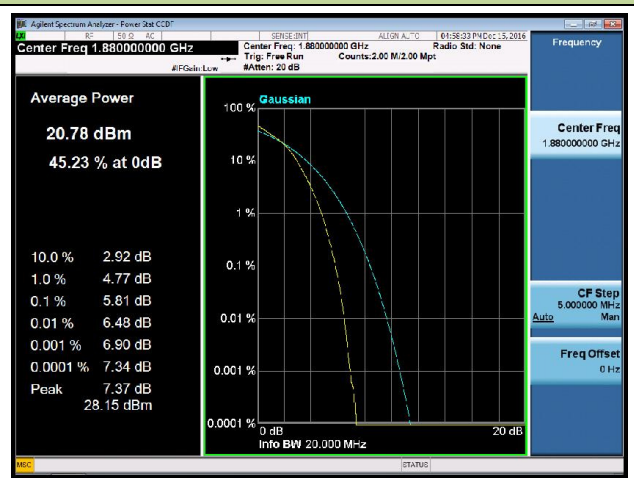

LTE Band 4 / 20MHz / QPSK

Low CH / 1RB

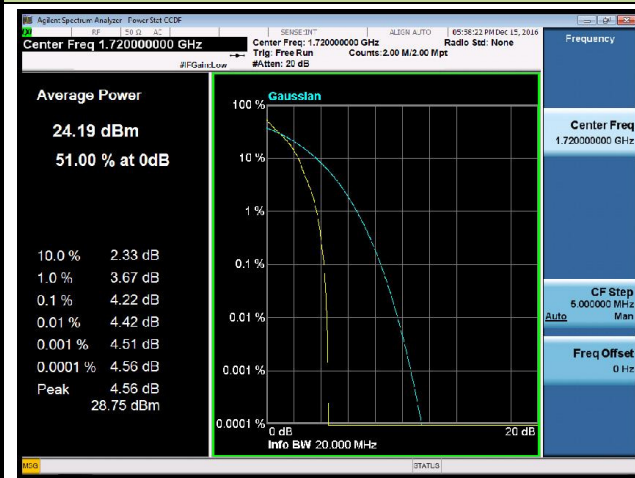

Low CH Full RB

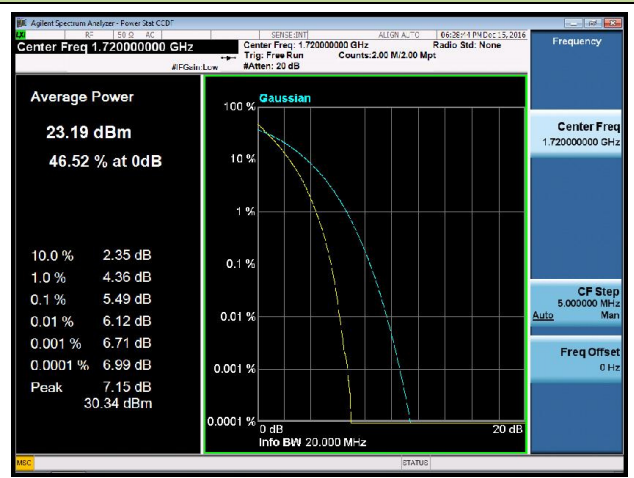

Mid CH / 1RB

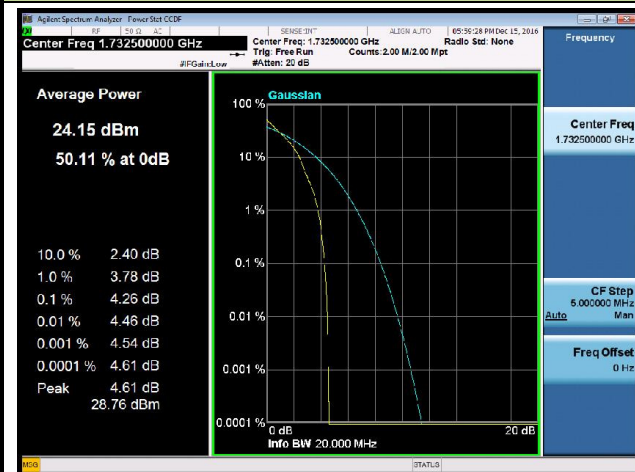

Mid CH Full RB

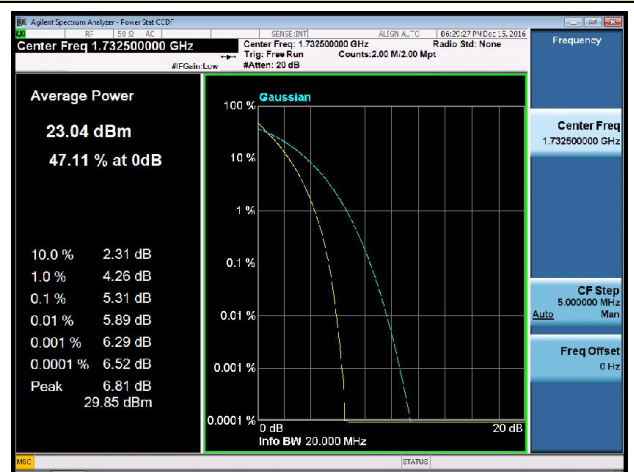

High CH / 1RB

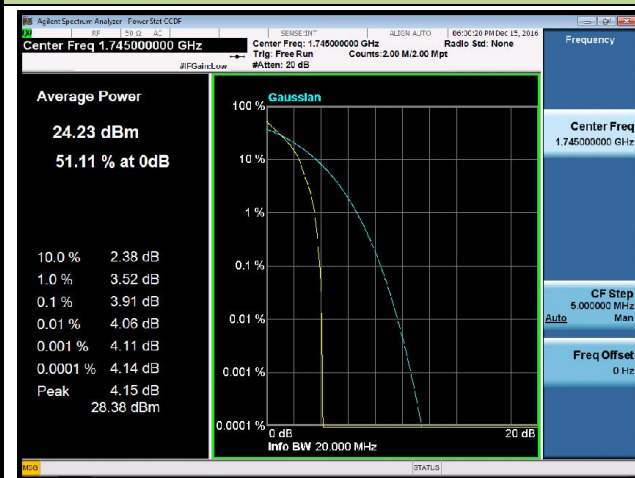

High CH Full RB

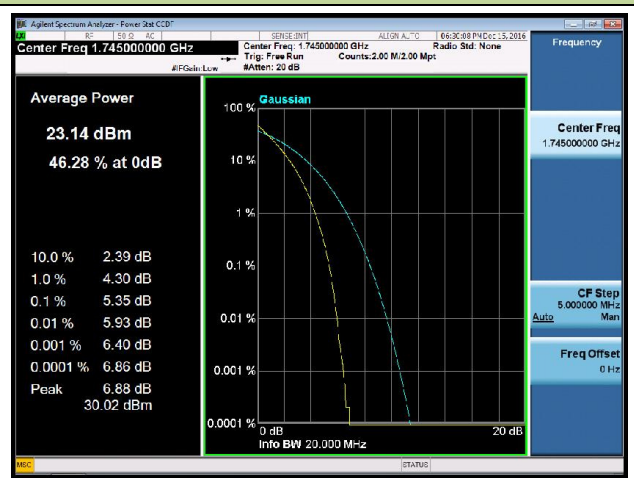

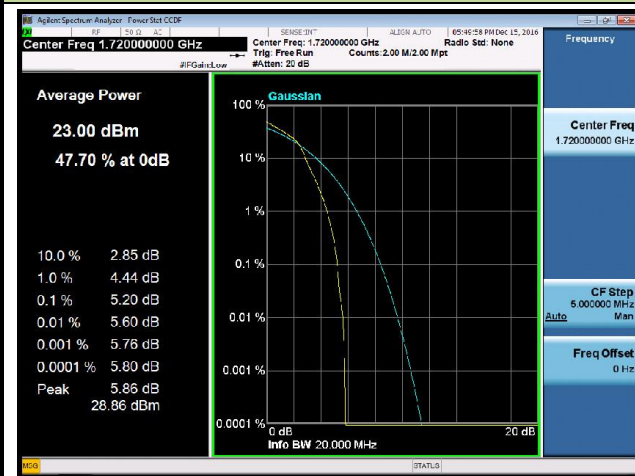
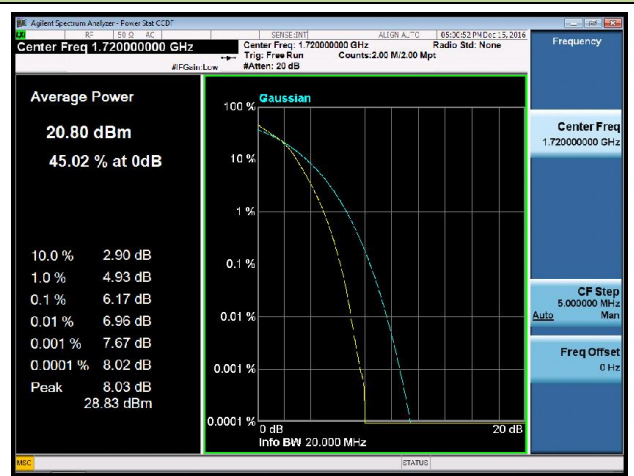
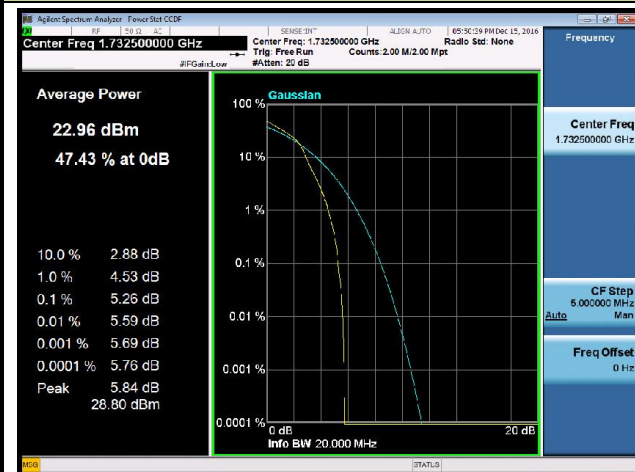
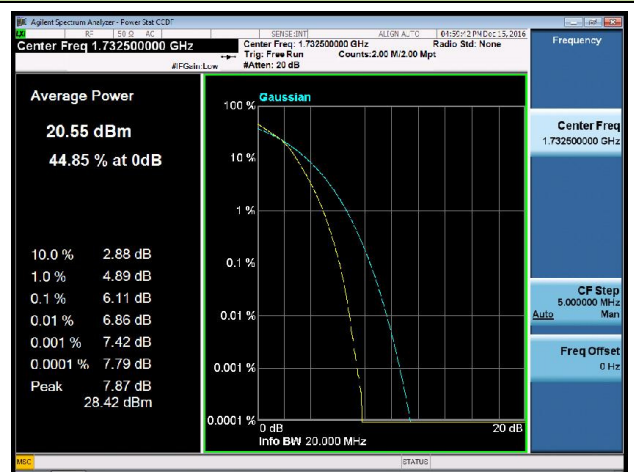
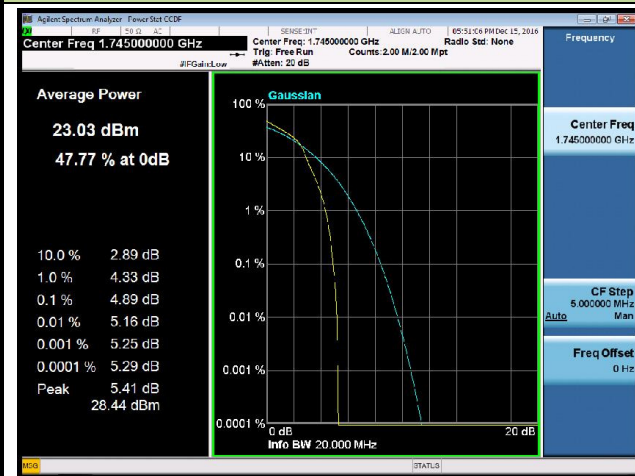
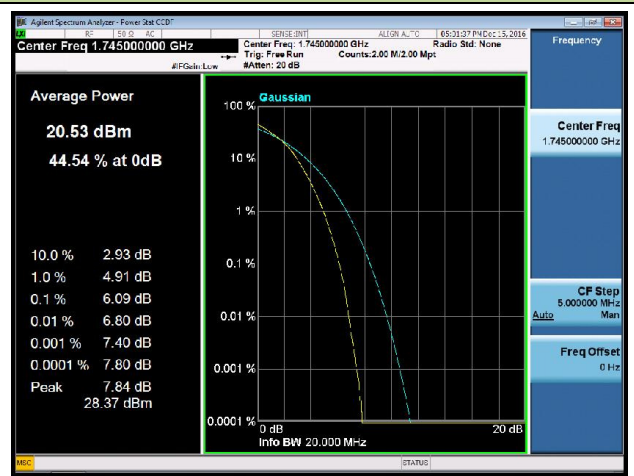
LTE Band 4 / 20MHz / 16-QAM
Low CH / 1RB

Low CH Full RB

Mid CH / 1RB

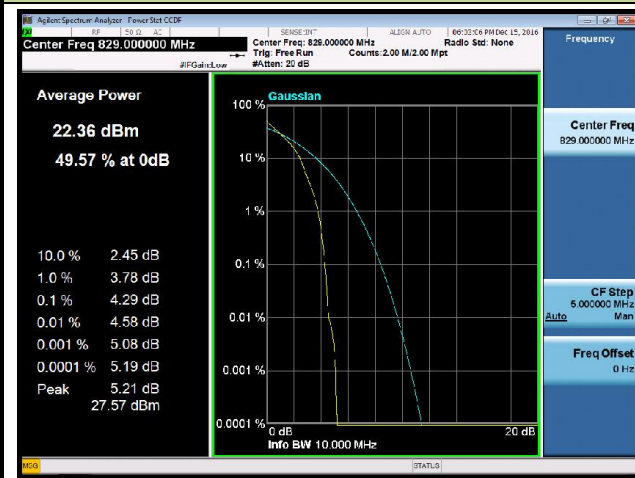
Mid CH Full RB

High CH / 1RB

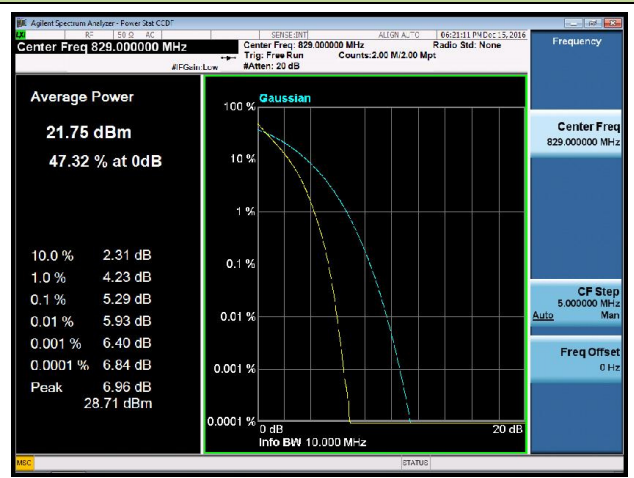
High CH Full RB

LTE Band 5 / 10MHz / QPSK

Low CH / 1RB



Low CH Full RB



Mid CH / 1RB

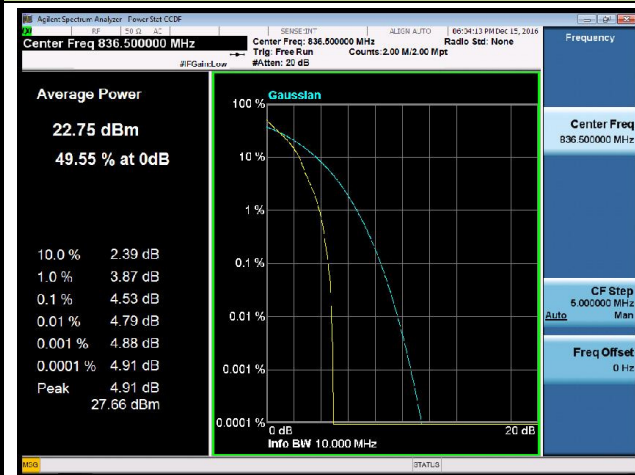

Mid CH Full RB

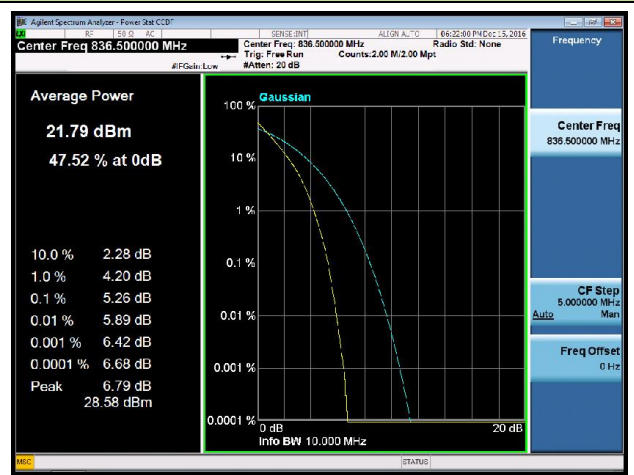

High CH / 1RB

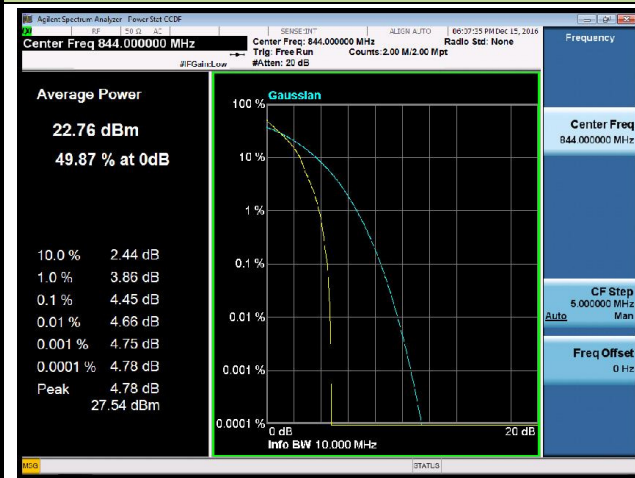

High CH Full RB

