



## FCC - TEST REPORT

Report Number : **68.940.21.0067.01** Date of Issue: July 5, 2023

Model : **NL69K111X; NL69E111X; NL69K112X; NL69E112X; NL69K113X; NL69E113X; NL69K114X; NL69E114X; NL69K115X; NL69E115X**  
**['X' can be 0-9, stands for internal production code]**

Product Type : Nanoleaf 4D light strip

Applicant : NANOGRID LIMITED

Address : Room 1301, 13/F, Excel Centre, 483A Castle Peak Road, Lai Chi Kok,  
Kowloon, HONG KONG

Production Facility : SEVECO GLOBAL LTD.

Address : 2 Jianxiang St. Hanxishui Chashan Town, 523377 Dongguan,  
Guangdong, PEOPLE'S REPUBLIC OF CHINA

Test Result :  **Positive**       **Negative**

Total pages including Appendices : 35

*Any use for advertising purposes must be granted in writing. This technical report may only be quoted in full. This report is the result of a single examination of the object in question and is not generally applicable evaluation of the quality of other products in regular production. For further details, please see testing and certification regulation, chapter A-3.4.*



# 1 Table of Contents

1	Table of Contents .....	2
2	Details about the Test Laboratory .....	3
3	Description of the Equipment under Test .....	4
4	Summary of Test Standards .....	5
5	Summary of Test Results .....	6
6	General Remarks .....	7
7	Test Setups .....	8
8	Systems test configuration .....	10
9	Technical Requirement .....	11
9.1	Conducted Emission .....	11
9.2	Conducted peak output power .....	14
9.3	6dB bandwidth .....	17
9.4	Power spectral density .....	20
9.5	Spurious RF conducted emissions .....	23
9.6	Band edge .....	29
9.7	Spurious radiated emissions for transmitter .....	31
10	Test Equipment List .....	34
11	System Measurement Uncertainty .....	35



## 2 Details about the Test Laboratory

### Details about the Test Laboratory

#### Test Site 1

Company name: TÜV SÜD Certification and Testing (China) Co., Ltd. Shenzhen Branch  
Building 12&13, Zhiheng Wisdomland Business Park,  
Nantou Checkpoint Road 2, Nanshan District,  
Shenzhen City, 518052,  
P. R. China

FCC Registration Number: 514049

FCC Designation Number: CN5009

ISED#: 10320A

CAB identifier: CN0077

Telephone: 86 755 8828 6998  
Fax: 86 755 8828 5299

### 3 Description of the Equipment under Test

Product:	Nanoleaf 4D light strip
Model no.:	NL69K1150
FCC ID:	2AEWY-NL69
Ratings:	12VDC, 2A (Powered by Adapter)
Adapter:	Model: VS024-1200200HU Input: 100-240VAC; 50/60Hz; 0.6A Output: 12.0VDC; 2.0A
RF Transmission Frequency:	2405MHz-2480MHz
No. of Operated Channel:	16
Modulation:	QPSK
Antenna Type:	PCB Antenna
Antenna Gain:	3.46dBi
Description of the EUT:	The Equipment Under Test (EUT) is a Nanoleaf 4D light strip supports BLE, Thread and Wi-Fi functions.



## 4 Summary of Test Standards

Test Standards	
FCC Part 15 Subpart C 10-1-2021 Edition	PART 15 - RADIO FREQUENCY DEVICES Subpart C - Intentional Radiators

All the test methods were according to KDB558074 D01 v05r02 DTS Measurement Guidance and ANSI C63.10 (2013).

## 5 Summary of Test Results

Technical Requirements				
FCC Part 15 Subpart C				
Test Condition		Pages	Test Result	Test Site
§15.207	Conducted emission AC power port	10	Pass	Site 1
§15.247(b)(1)	Conducted AV output power for FHSS	--	N/A	--
§15.247(b)(3)	Conducted peak output power for DTS	13	Pass	Site 1
§15.247(e)	Power spectral density	19	Pass	Site 1
§15.247(a)(2)	6dB bandwidth	16	Pass	Site 1
§15.247(a)(1)	20dB Occupied bandwidth	--	N/A	--
§15.247(a)(1)	Carrier frequency separation	--	N/A	--
§15.247(a)(1)(iii)	Number of hopping frequencies	--	N/A	--
§15.247(a)(1)(iii)	Dwell Time	--	N/A	--
§15.247(d)	Spurious RF conducted emissions	22	Pass	Site 1
§15.247(d)	Band edge	28	Pass	Site 1
§15.247(d) & §15.209 & §15.205	Spurious radiated emissions for transmitter	30	Pass	Site 1
§15.203	Antenna requirement	See note 1	Pass	--

Remark 1: N/A – Not Applicable.

Note 1: The EUT uses a PCB Antenna 3.46dBi max. According to §15.203, it is considered sufficiently to comply with the provisions of this section.

## 6 General Remarks

This submittal(s) (test report) is intended for FCC ID: 2AEWY-NL69 complies with Section 15.207, 15.205, 15.209, 15.247 of the FCC Part 15, Subpart C Rules.  
This report is only for Thread.

### Model list for LED luminaires:

Model No.	Rated Voltage (VAC)	Rated Power (W)	LED driver	LED Qty. (pcs)	Length (m)
NL69K111X; NL69E111X	100-240	9	VS024- 1200200HU	30	1
NL69K112X; NL69E112X		18		60	2
NL69K113X; NL69E113X		24		90	3
NL69K114X; NL69E114X		24		120	4
NL69K115X; NL69E115X		24		156	5,2

Remark: All models in the same table are the same except for model no.

Unless otherwise specified, model NL69K1150 was chosen as representative model to perform all tests.

### SUMMARY:

All tests according to the regulations cited on page 5 were

- Performed

- **Not** Performed

The Equipment under Test

- **Fulfills** the general approval requirements.

- **Does not** fulfill the general approval requirements.

Sample Received Date: April 10, 2023

Testing Start Date: April 10, 2023

Testing End Date: April 21, 2023

- TÜV SÜD Certification and Testing (China) Co., Ltd. Shenzhen Branch -

Reviewed by:

Prepared by:

Tested by:



Dawi Xu  
EMC Project Manager





Henry Chen  
EMC Project Engineer



Carry Cai  
Test Engineer

## 7 Test Setups

### 7.1 Radiated test setups

9kHz - 30MHz

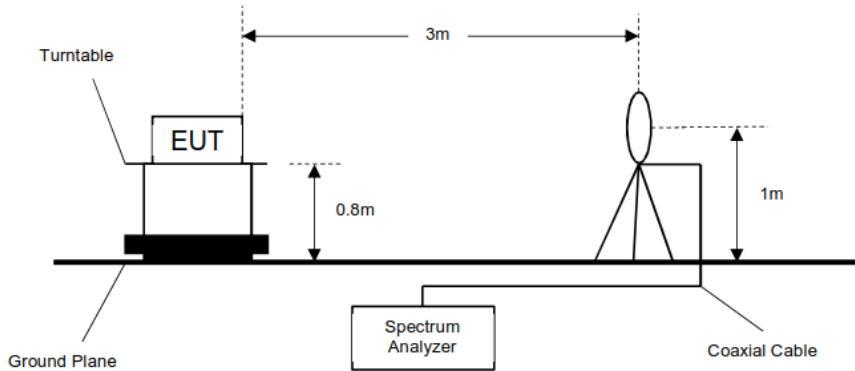

Below 1GHz

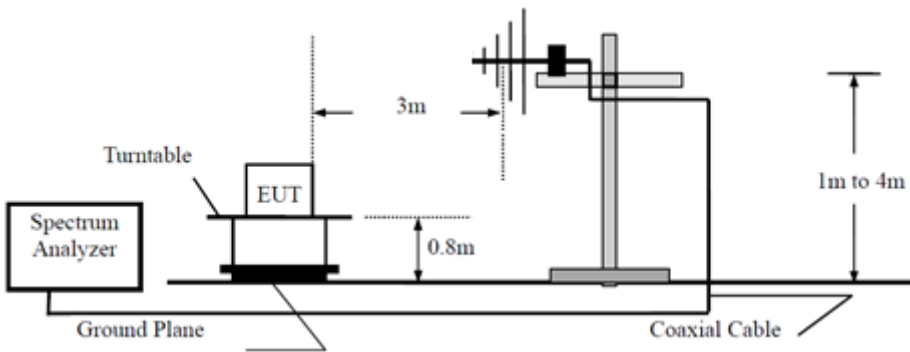

Above 1GHz

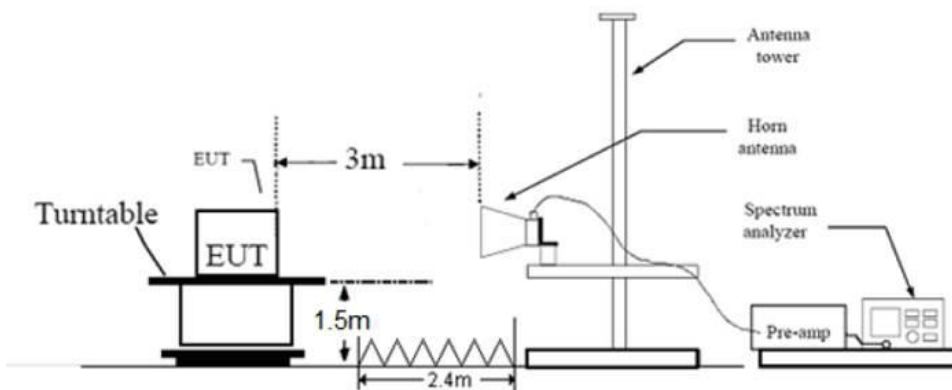



## 7.2 Conducted RF test setups

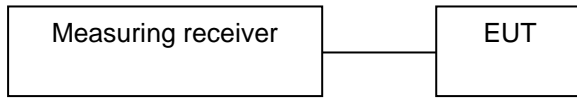

## 7.3 AC Power Line Conducted Emission test setups

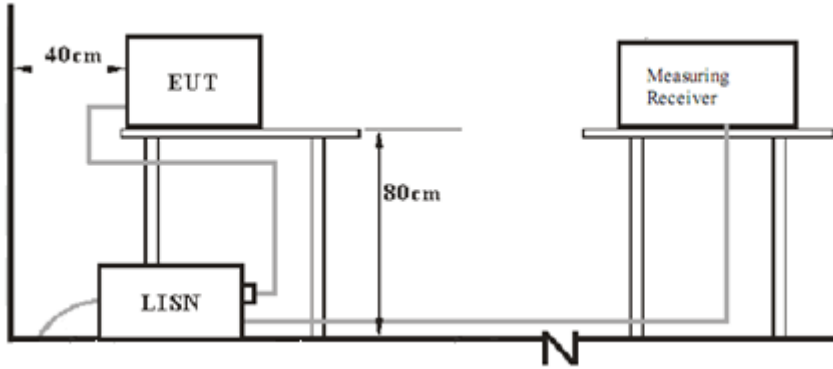

## 8 Systems test configuration

### Auxiliary Equipment Used during Test:

Description	Manufacturer	Model no.	S/N
COMPUTER	HP	HP PROBOOK 455 15.6 INCH G9 NOTEBOOK PC	5CD302CY5H
ADAPTOR	HP	TPN-CA16	L25298-002

### Test software information:

Test Software Version	SecureCRT	
Modulation	Setting TX Power	Packet Type
GFSK	70	---

The system was configured to channel 11, 19, and 26 for the test.

## 9 Technical Requirement

### 9.1 Conducted Emission

#### Test Method

1. The EUT was placed 0.4 meter from the conducting wall of the shielding room was kept at least 80 centimeters from any other grounded conducting surface.
2. Connect EUT to the power mains through a line impedance stabilization network (LISN).
3. All the support units are connecting to the other LISN.
4. The LISN provides 50 ohm coupling impedance for the measuring instrument.
5. Both sides of AC line were checked for maximum conducted interference.
6. The frequency range from 150 kHz to 30 MHz was searched.
7. Set the test-receiver system to Peak Detect Function and specified bandwidth (IF Bandwidth = 9kHz) with Maximum Hold Mode. Then measurement is also conducted by Average Detector and Quasi-Peak Detector Function respectively.

#### Limit

According to §15.207, conducted emissions limit as below:

Frequency MHz	QP Limit dB $\mu$ V	AV Limit dB $\mu$ V
0.150-0.500	66-56*	56-46*
0.500-5	56	46
5-30	60	50

\*Decreasing linearly with logarithm of the frequency

## Conducted Emission

Product Type : Nanoleaf 4D light strip  
 M/N : NL69K1150  
 Operating Condition : Normal working with transmitting  
 Test Specification : Power Line, Live  
 Comment : AC 120V/60Hz

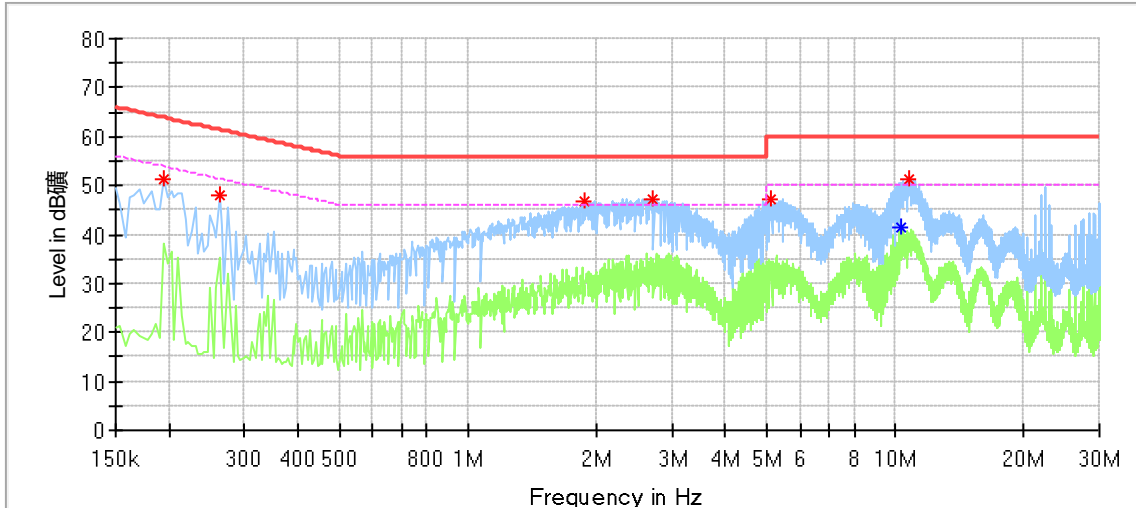

### Critical Freqs

Frequency (MHz)	MaxPeak (dBµV)	Average (dBµV)	Limit (dBµV)	Margin (dB)	Line	Corr. (dB)
0.194000	51.43	---	63.86	12.44	L1	9.59
0.262000	48.09	---	61.37	13.28	L1	9.60
1.882000	46.59	---	56.00	9.41	L1	9.65
2.694000	47.37	---	56.00	8.63	L1	9.68
5.086000	47.12	---	60.00	12.88	L1	9.78
10.310000	---	41.39	50.00	8.61	L1	9.92
10.722000	51.14	---	60.00	8.86	L1	9.93

Remark :

Level=Reading Level + Correction Factor

Correction Factor=Cable Loss + LISN Factor

(The Reading Level is recorded by software which is not shown in the sheet)

## Conducted Emission

Product Type : Nanoleaf 4D light strip  
 M/N : NL69K1150  
 Operating Condition : Normal working with transmitting  
 Test Specification : Power Line, Neutral  
 Comment : AC 120V/60Hz

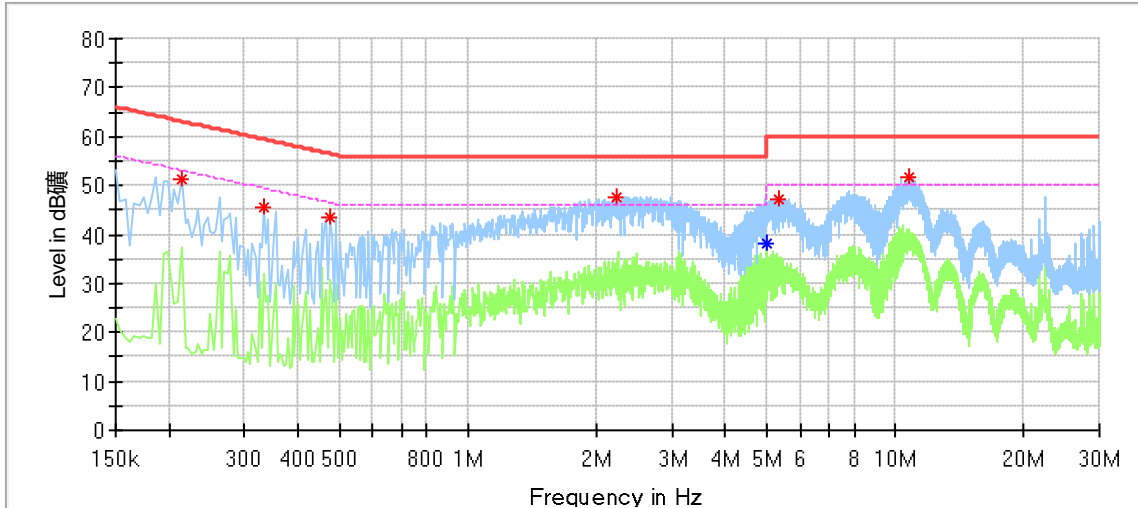

### Critical Freqs

Frequency (MHz)	MaxPeak (dBµV)	Average (dBµV)	Limit (dBµV)	Margin (dB)	Line	Corr. (dB)
0.214000	51.33	---	63.05	11.72	N	9.59
0.334000	45.45	---	59.35	13.90	N	9.61
0.474000	43.43	---	56.44	13.01	N	9.62
2.222000	47.50	---	56.00	8.50	N	9.66
4.986000	---	38.00	46.00	8.00	N	9.77
5.350000	47.19	---	60.00	12.81	N	9.78
10.814000	51.82	---	60.00	8.18	N	9.93

Remark :

Level=Reading Level + Correction Factor

Correction Factor=Cable Loss + LISN Factor

(The Reading Level is recorded by software which is not shown in the sheet)

## 9.2 Conducted peak output power

### Test Method

1. The EUT was placed on 0.8m height table, the RF output of EUT was connected to the spectrum analyzer by RF cable. The path loss was compensated to the results for each measurement.
2. Set to the maximum power setting and enable the EUT transmit continuously
3. Use the following test receiver settings:  
Span = approximately 5 times the 20dB bandwidth, centered on a hopping channel  
RBW > the 20dB bandwidth of the emission being measured, VBW ≥ RBW,  
Sweep = auto, Detector function = peak, Trace = max hold
4. Allow the trace to stabilize. Use the marker-to-peak function to set the marker to the peak of the emission. The indicated level is the peak output power and record the results in the test report.
5. Repeat above procedures until all frequencies measured were complete.

### Limits

According to §15.247 (b) (3), conducted peak output power limit as below:

Frequency Range MHz	Limit W	Limit dBm
2400-2483.5	≤1	≤30

Test result as below table

Frequency MHz	Conducted peak Output Power dBm	Antenna Gain dBi	EIRP dBm	Result
Top channel 2402MHz	6.13	3.46	9.59	Pass
Middle channel 2440MHz	6.33	3.46	9.79	Pass
Bottom channel 2480MHz	5.99	3.46	9.45	Pass

### Note:

EIRP [dBm] = A [dBm] + G[dBi]. Where, A = Average Power, G = Antenna Gain

### Test Graphs

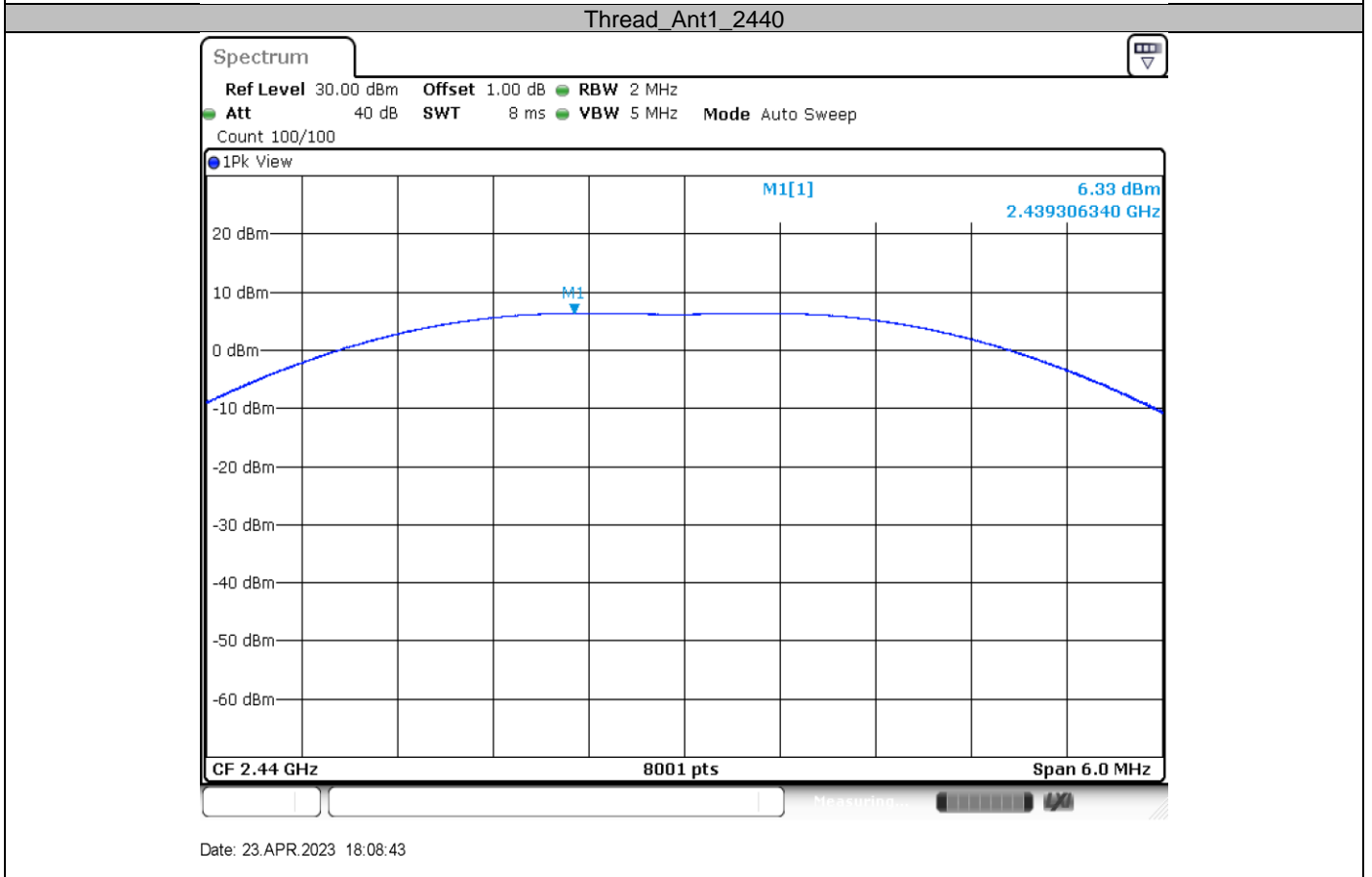
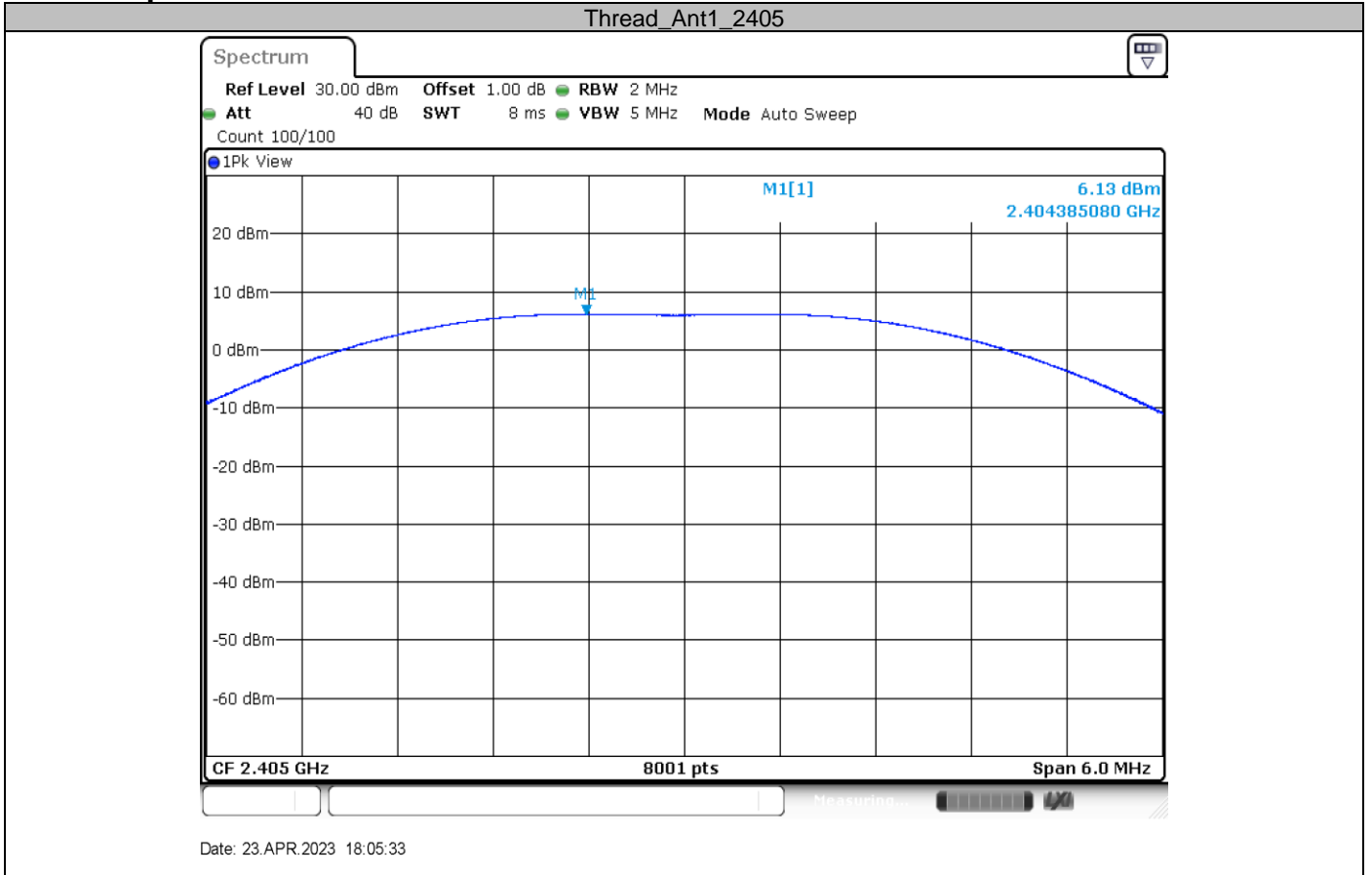



Thread\_Ant1\_2480

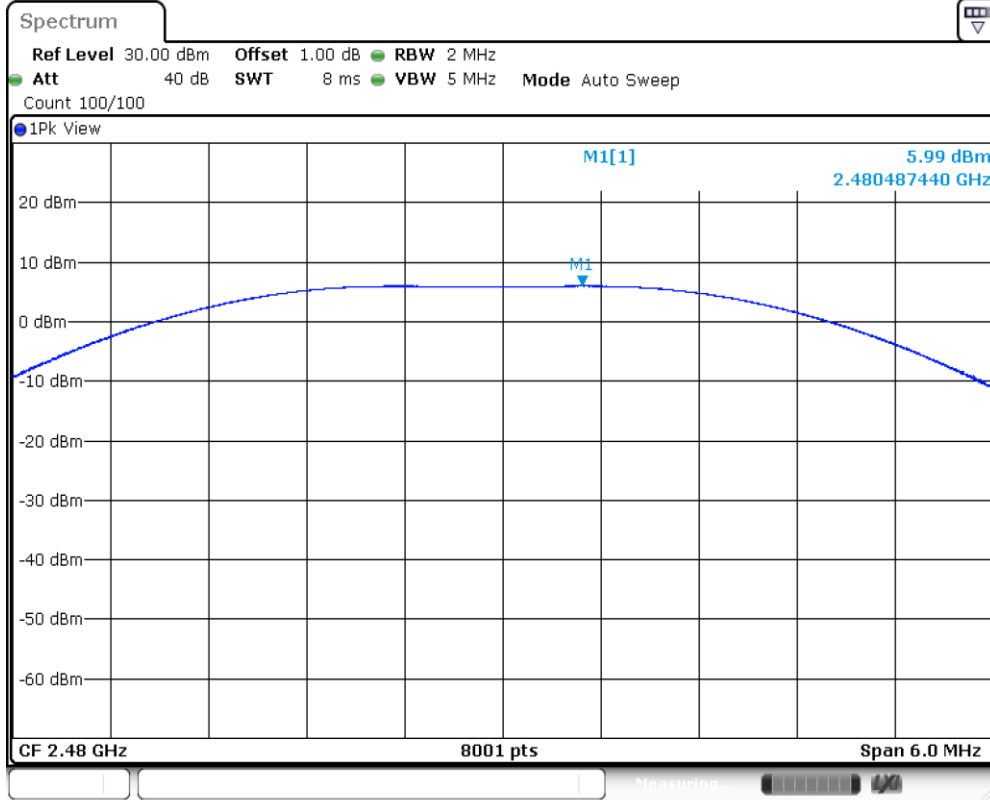

Date: 23.APR.2023 18:10:05



### 9.3 6dB bandwidth

#### Test Method

1. The RF output of EUT was connected to the spectrum analyzer. The path loss was compensated to the results for each measurement.
2. Set to the maximum power setting, the instrument center frequency is set to the nominal EUT channel center frequency enable the EUT transmit continuously.
3. Use the following spectrum analyzer settings:  
RBW=100KHz, VBW $\geq$ 3RBW, Sweep = auto, Detector function = peak, Trace = max hold
4. Use the automatic bandwidth measurement capability of an instrument, use the X dB bandwidth mode with X set to 6 dB.
5. Allow the trace to stabilize, record the 6 dB Bandwidth value.

#### Limit

**Limit [kHz]**

—————  
 $\geq 500$

#### Test result

Test Mode	Channel (MHz)	Result (MHz)	Limit (KHz)	Verdict
Thread	2405	1.648	$\geq 500$	PASS
Thread	2440	1.644	$\geq 500$	PASS
Thread	2480	1.648	$\geq 500$	PASS

Test Graphs

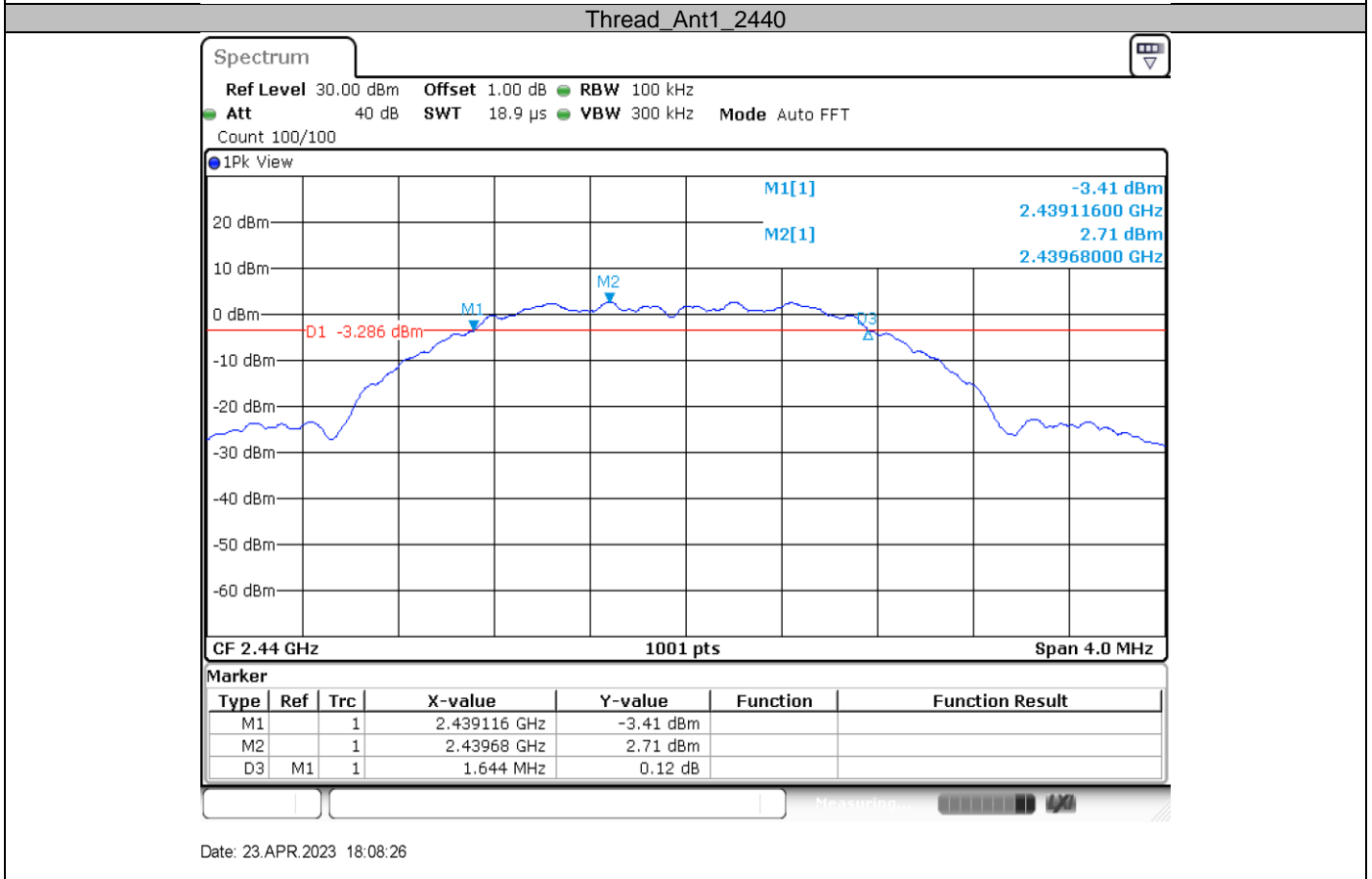
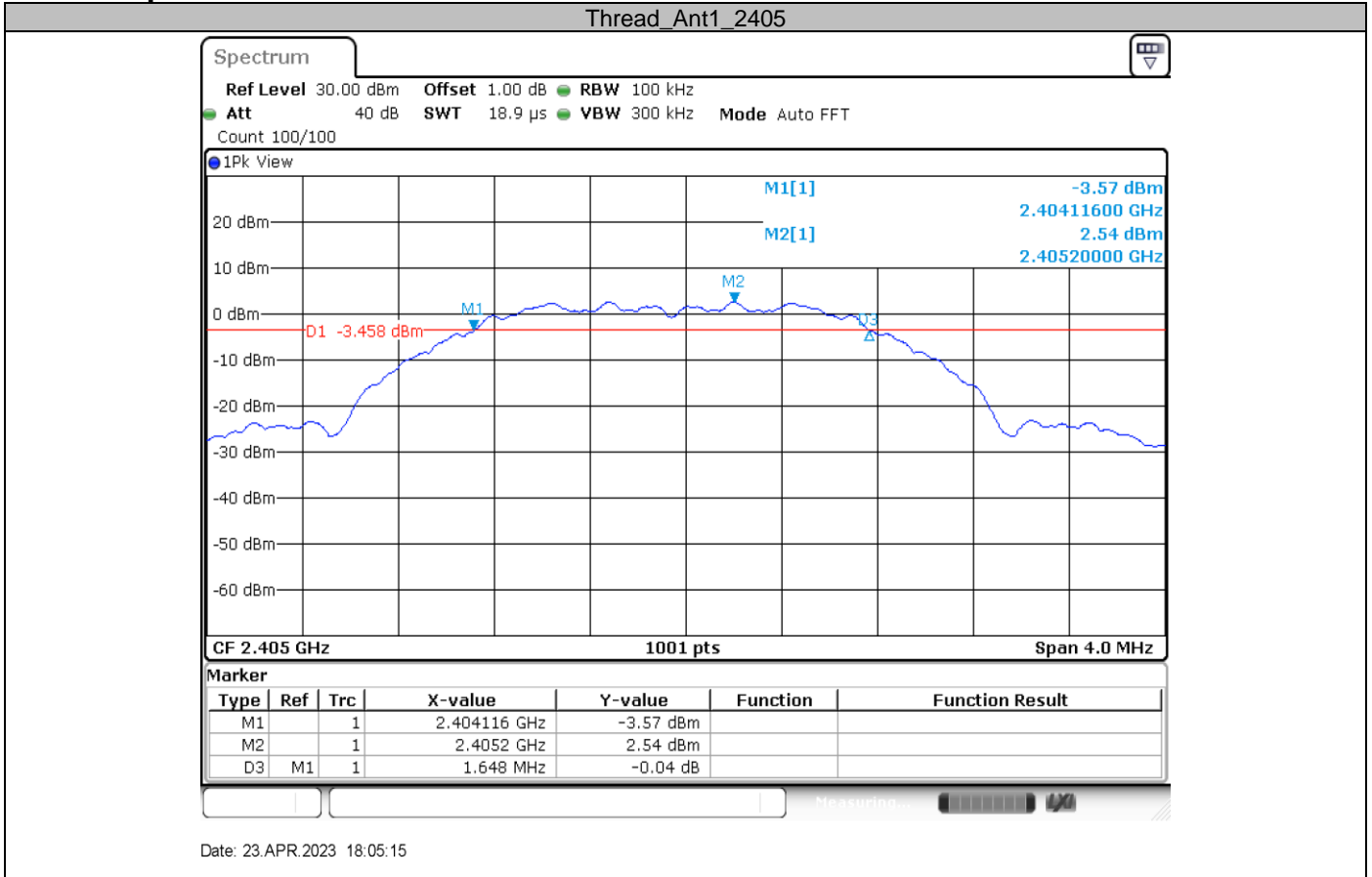

Thread\_Ant1\_2480

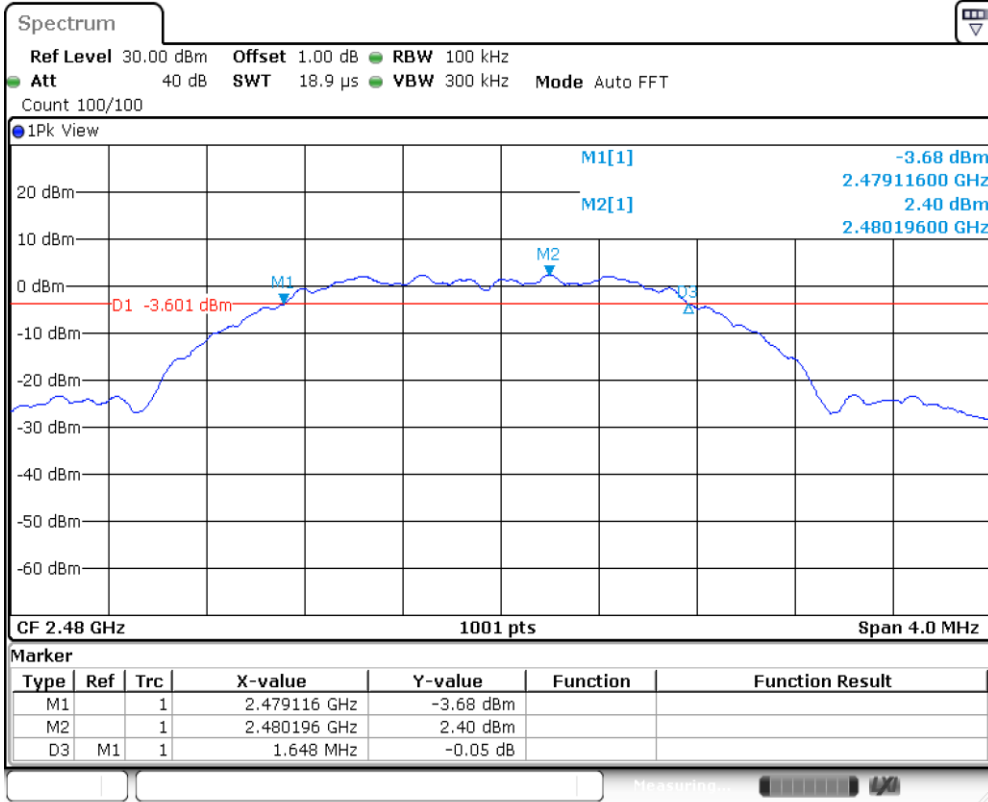

Date: 23.APR.2023 18:09:48

## 9.4 Power spectral density

### Test Method

This procedure shall be used if maximum peak conducted output power was used to demonstrate compliance:

1. The RF output of EUT was connected to the spectrum analyzer. The path loss was compensated to the results for each measurement.
2. Set to the maximum power setting, the instrument center frequency is set to the nominal EUT channel center frequency enable the EUT transmit continuously.
3. Use the following spectrum analyzer settings:
4. Set analyzer center frequency to DTS channel center frequency. RBW=3kHz, VBW $\geq$ 3RBW, Span=1.5 times DTS bandwidth, Detector=Peak, Sweep=auto, Trace= max hold.
5. Allow trace to fully stabilize, use the peak marker function to determine the maximum amplitude level within the RBW.
6. Repeat above procedures until other frequencies measured were completed.

### Limit

Limit [dBm/3KHz]

≤8

### Test result

Test Mode	Channel (MHz)	Result (dBm)	Limit	Verdict
Thread	2405	-9.14	8	PASS
Thread	2440	-8.9	8	PASS
Thread	2480	-9.24	8	PASS

### Test Graphs

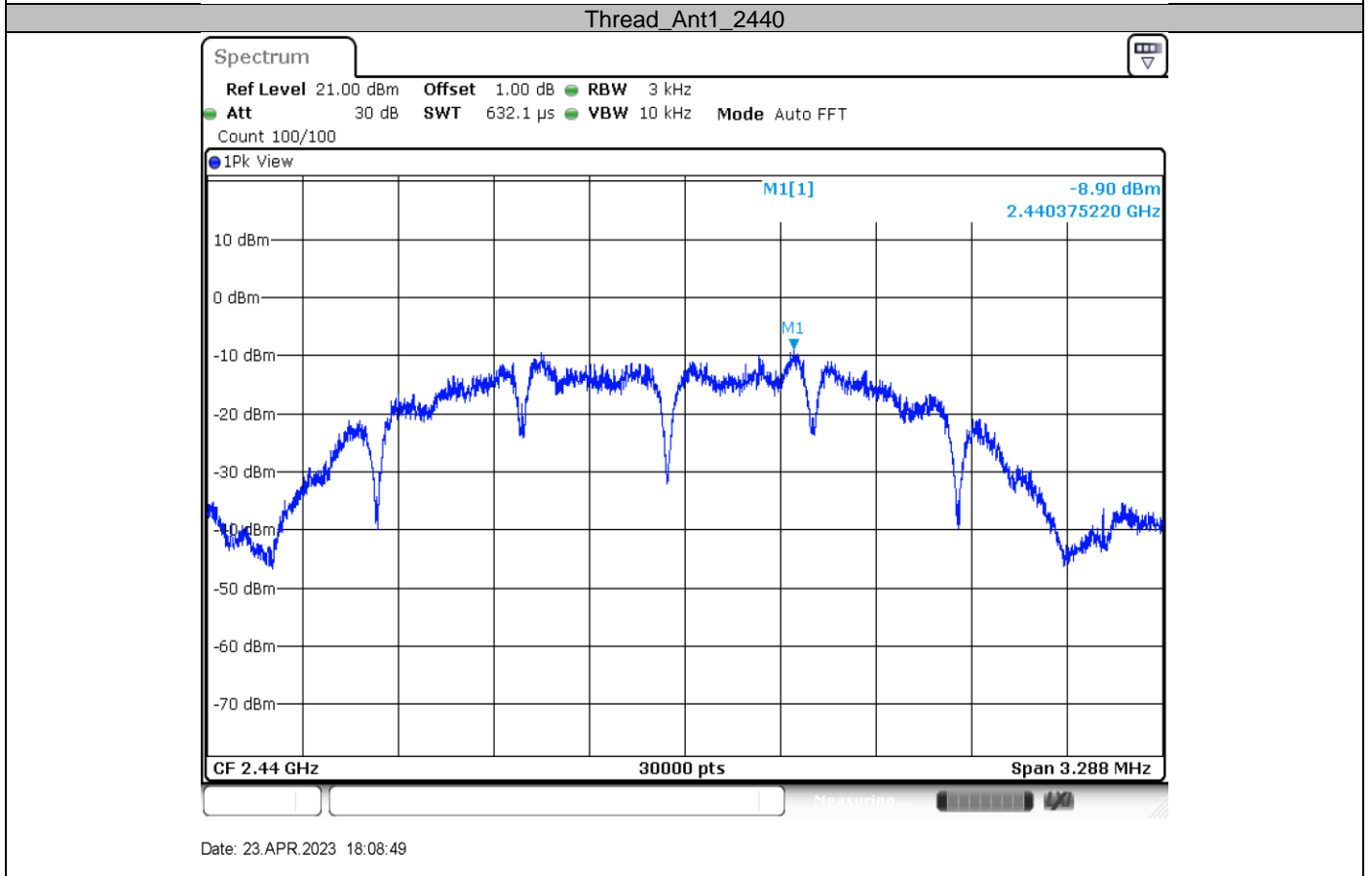
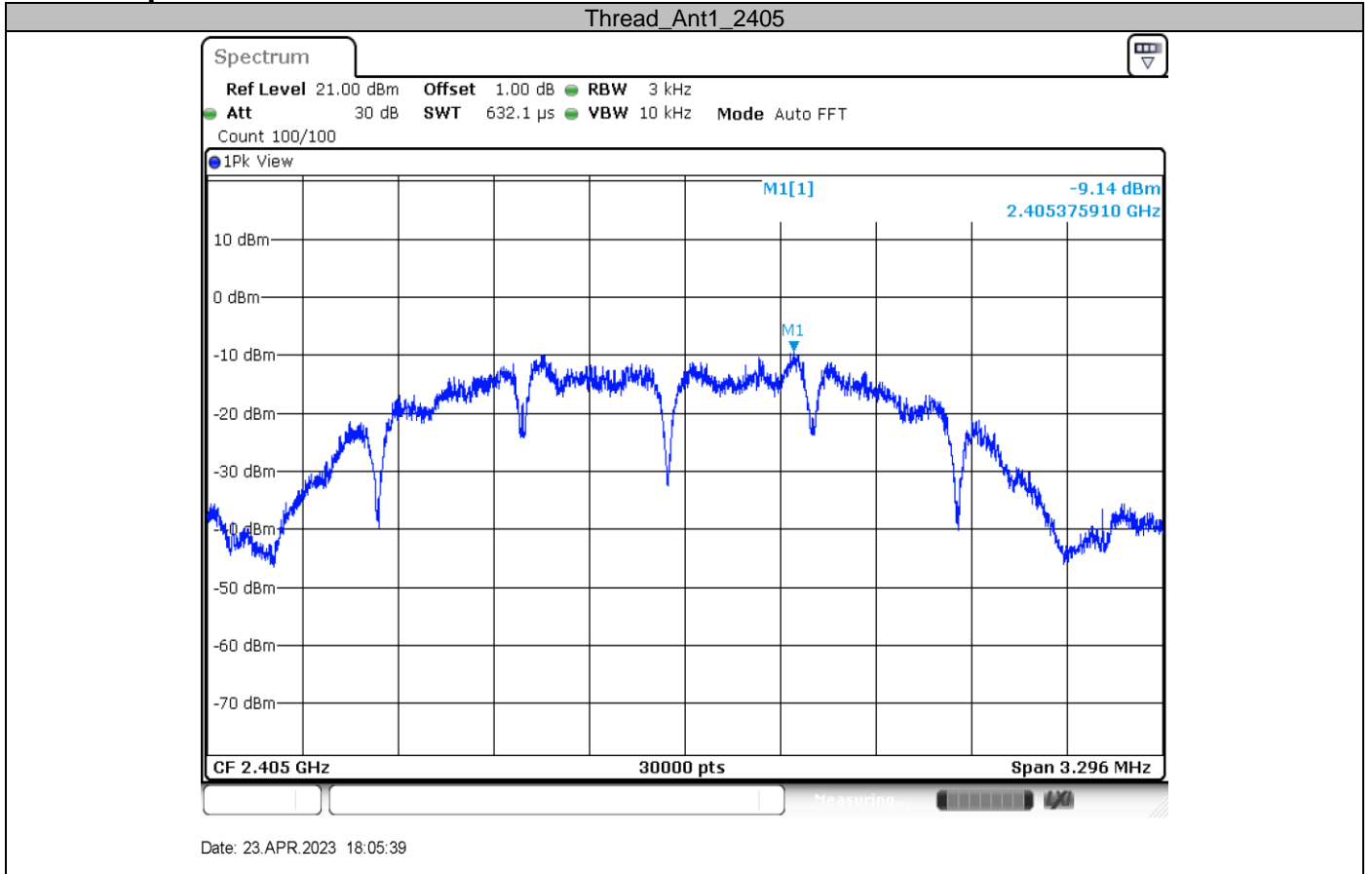

Thread\_Ant1\_2480

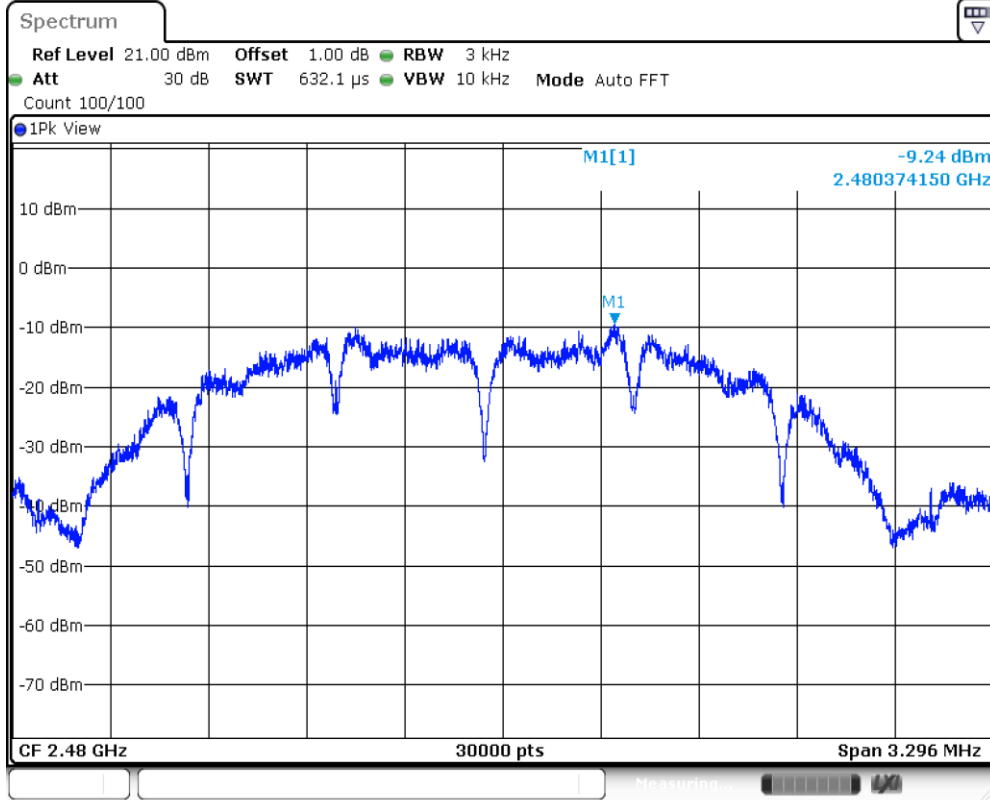

Date: 23.APR.2023 18:10:10



## 9.5 Spurious RF conducted emissions

### Test Method

1. The RF output of EUT was connected to the spectrum analyzer by RF cable. The path loss was compensated to the results for each measurement.
2. Set to the maximum power setting, the instrument center frequency is set to the nominal EUT channel center frequency enable the EUT transmit continuously.
3. Use the following spectrum analyzer settings:  
Span = wide enough to capture the peak level of the in-band emission and all spurious emissions (e.g., harmonics) from the lowest frequency generated in the EUT up through the 10<sup>th</sup> harmonic. Typically, several plots are required to cover this entire span.  
RBW = 100 kHz, VBW≥3RBW, Sweep = auto, Detector function = peak, Trace = max hold
4. Allow the trace to stabilize. Set the marker on the peak of any spurious emission recorded.
5. The level displayed must comply with the limit specified in this Section. Submit these plots.
6. Repeat above procedures until all frequencies measured were complete.

### Limit

In any 100 kHz bandwidth outside the frequency band in which the spread spectrum or digitally modulated device is operating, the RF power that is produced shall be at least 20 dB below that in the 100 kHz bandwidth within the band that contains the highest level of the desired power, based on either an RF conducted or a radiated measurement, provided that the transmitter demonstrates compliance with the peak conducted power limits. If the transmitter complies with the conducted power limits based on the use of RMS averaging over a time interval, as permitted under § 15.247(b)(3), the attenuation required shall be 30 dB instead of 20 dB.

Frequency Range MHz	Limit (dBc)
30-25000	-20

### Test Result

TestMode	Antenna	Channel	FreqRange	RefLevel	Result	Limit	Verdict
Thread	Ant1	2405	Reference	2.51	2.51	---	PASS
			30~1000	30~1000	-67.29	<=-17.49	PASS
			1000~26500	1000~26500	-51.74	<=-17.49	PASS
		2440	Reference	2.70	2.70	---	PASS
			30~1000	30~1000	-67.32	<=-17.3	PASS
			1000~26500	1000~26500	-52.68	<=-17.3	PASS
		2480	Reference	2.35	2.35	---	PASS
			30~1000	30~1000	-66.81	<=-17.65	PASS
			1000~26500	1000~26500	-52.41	<=-17.65	PASS

### Test Graphs

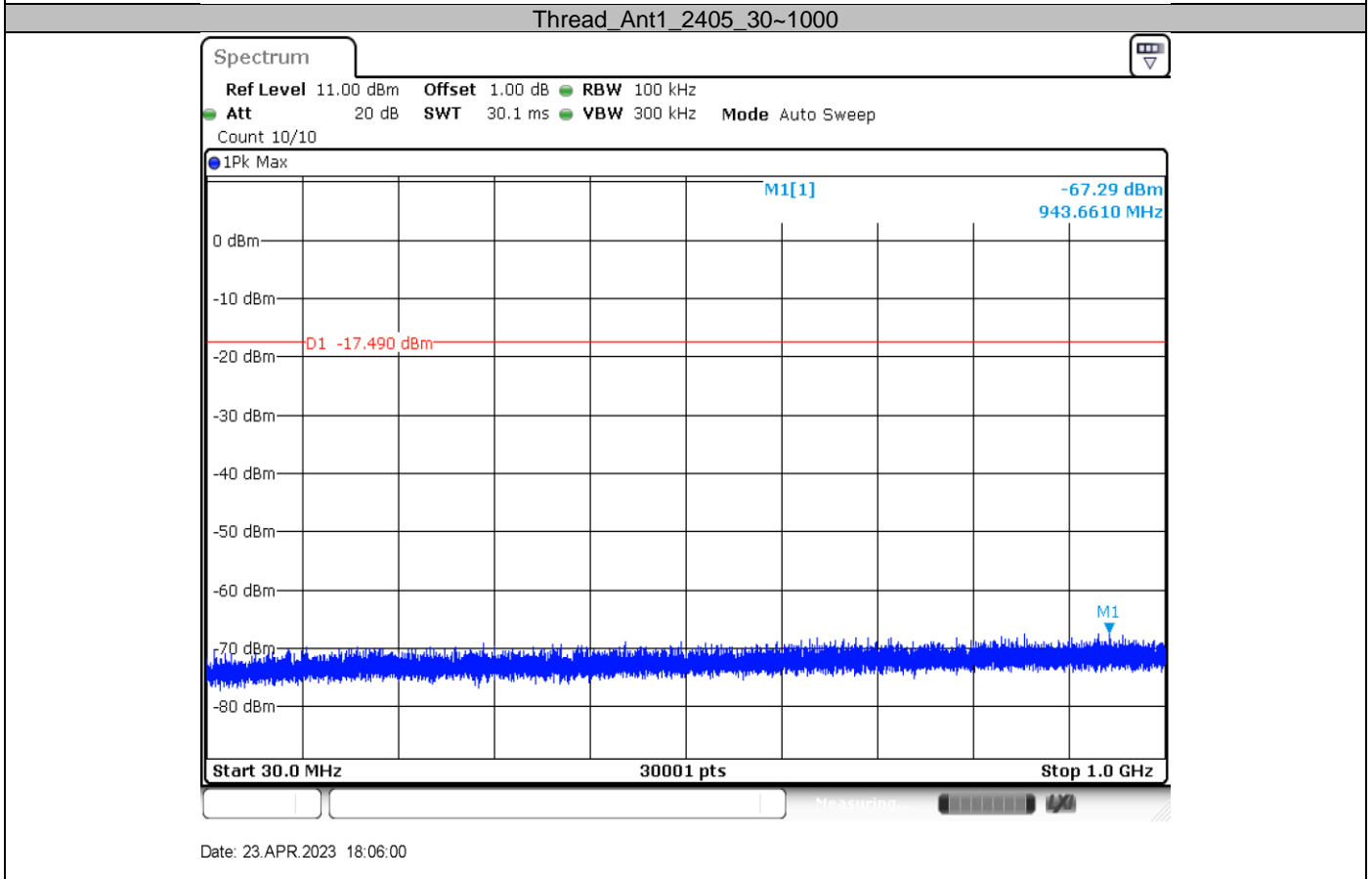
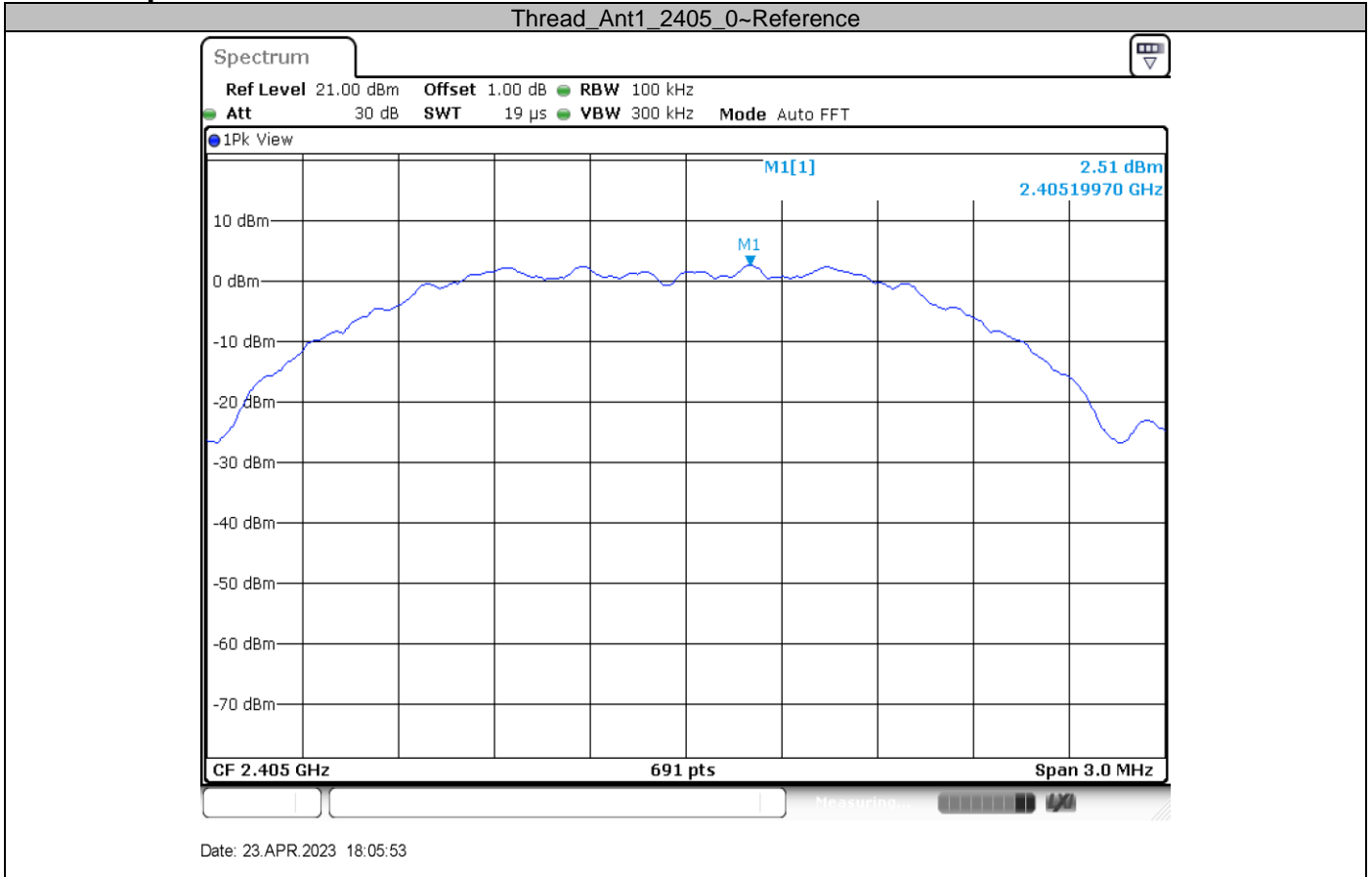



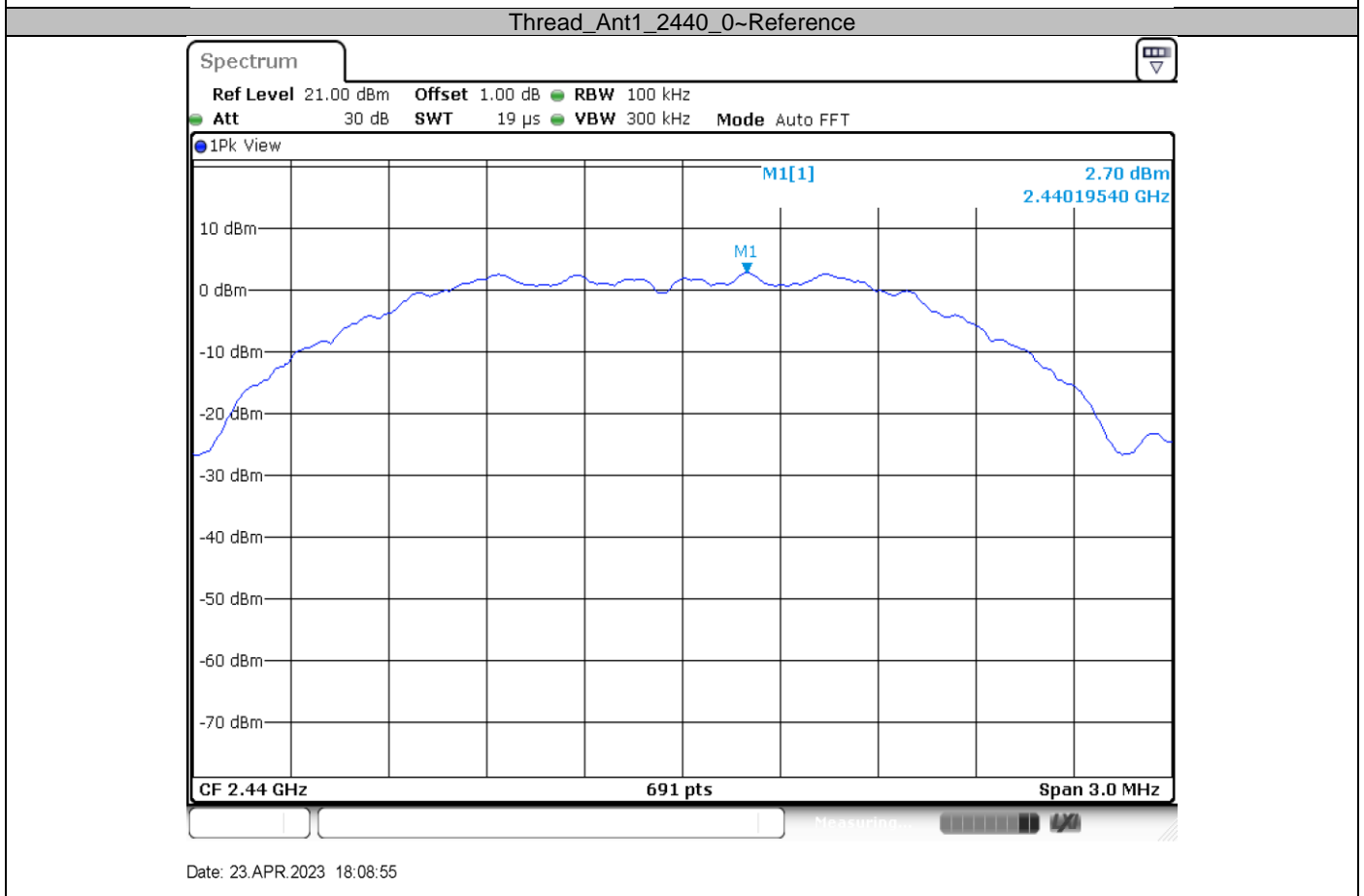
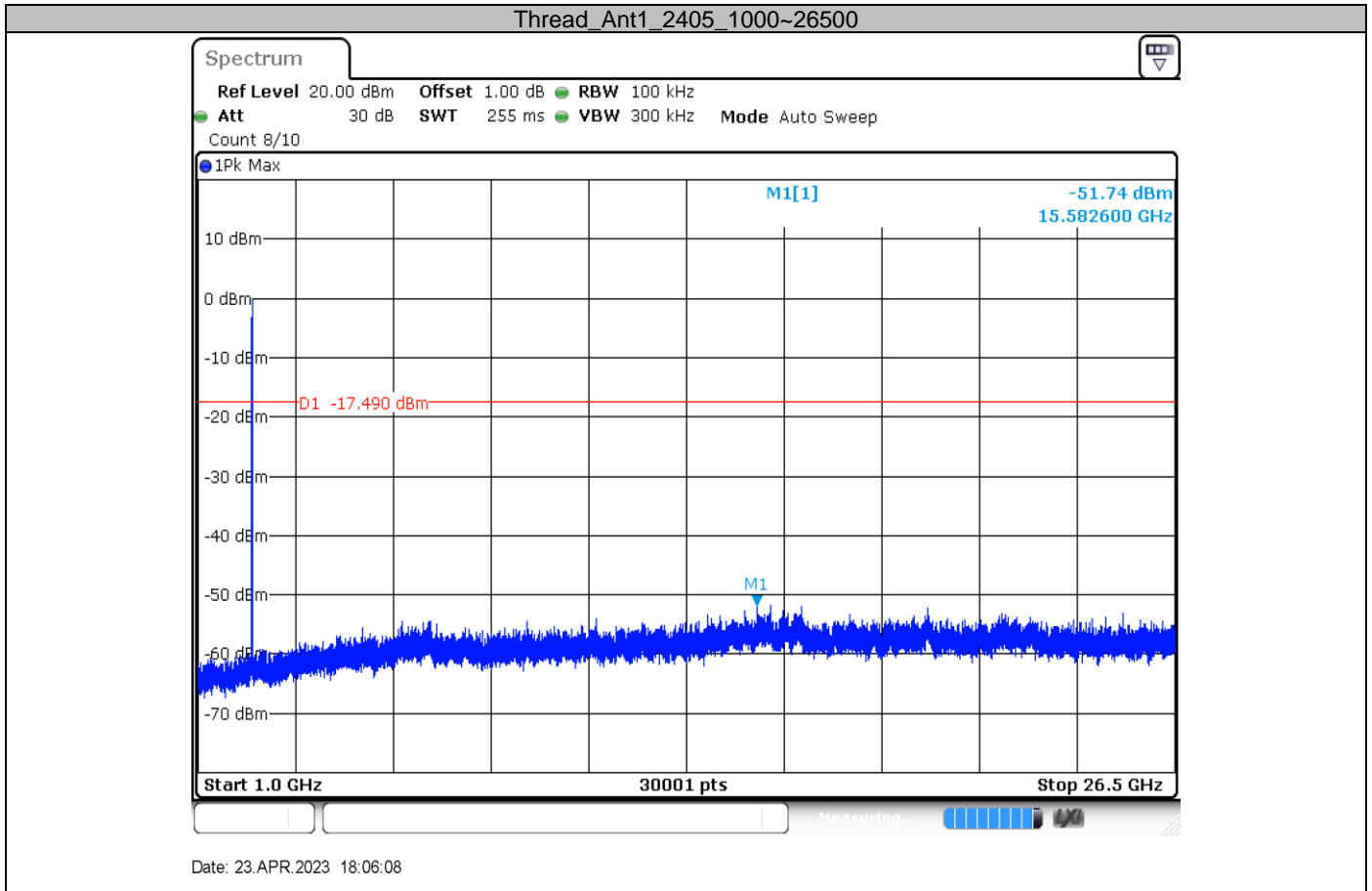



Thread\_Ant1\_2440\_30~1000

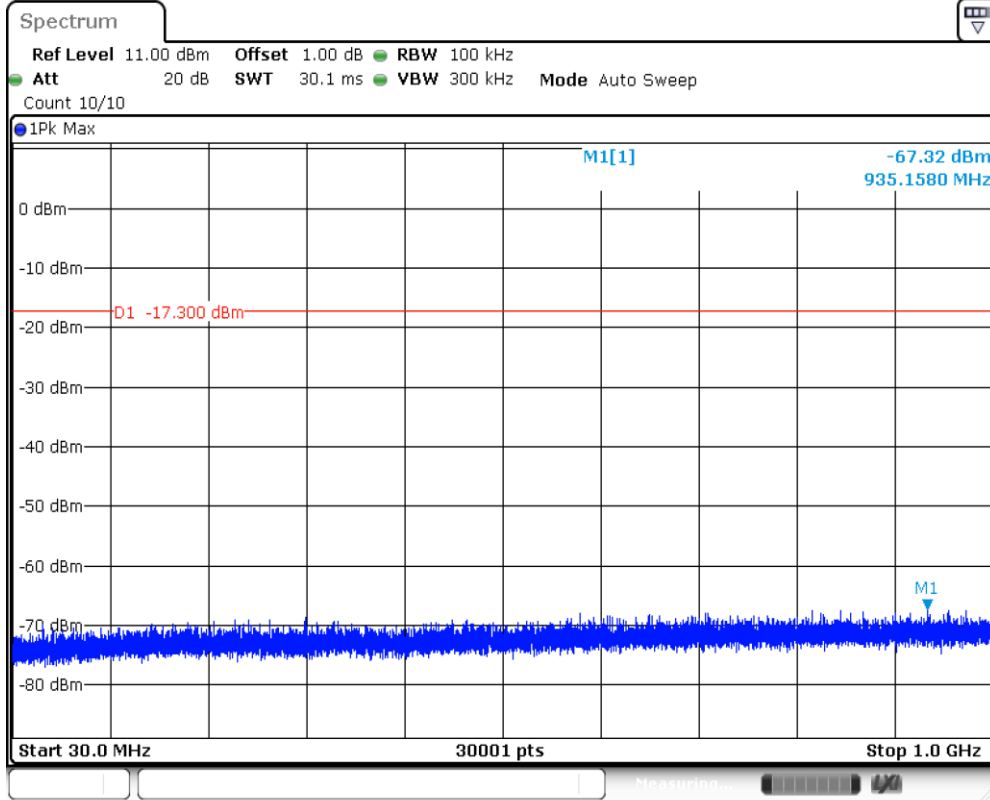

Date: 23.APR.2023 18:09:01

Thread\_Ant1\_2440\_1000~26500

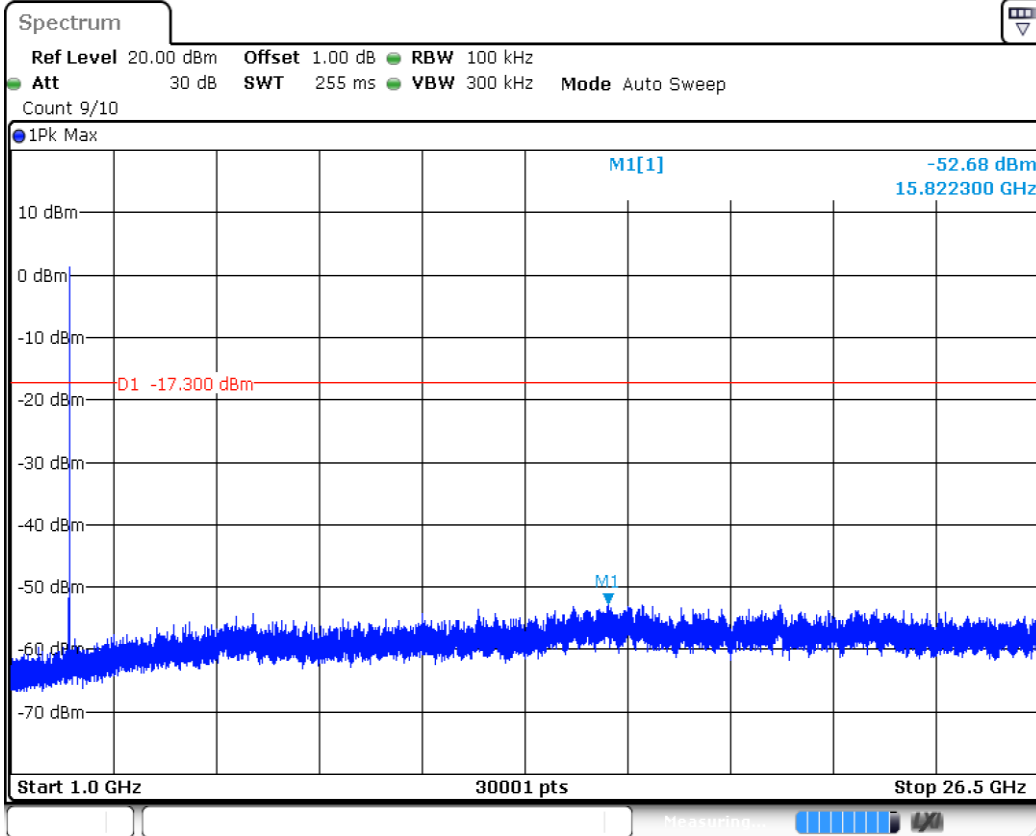

Date: 23.APR.2023 18:09:09

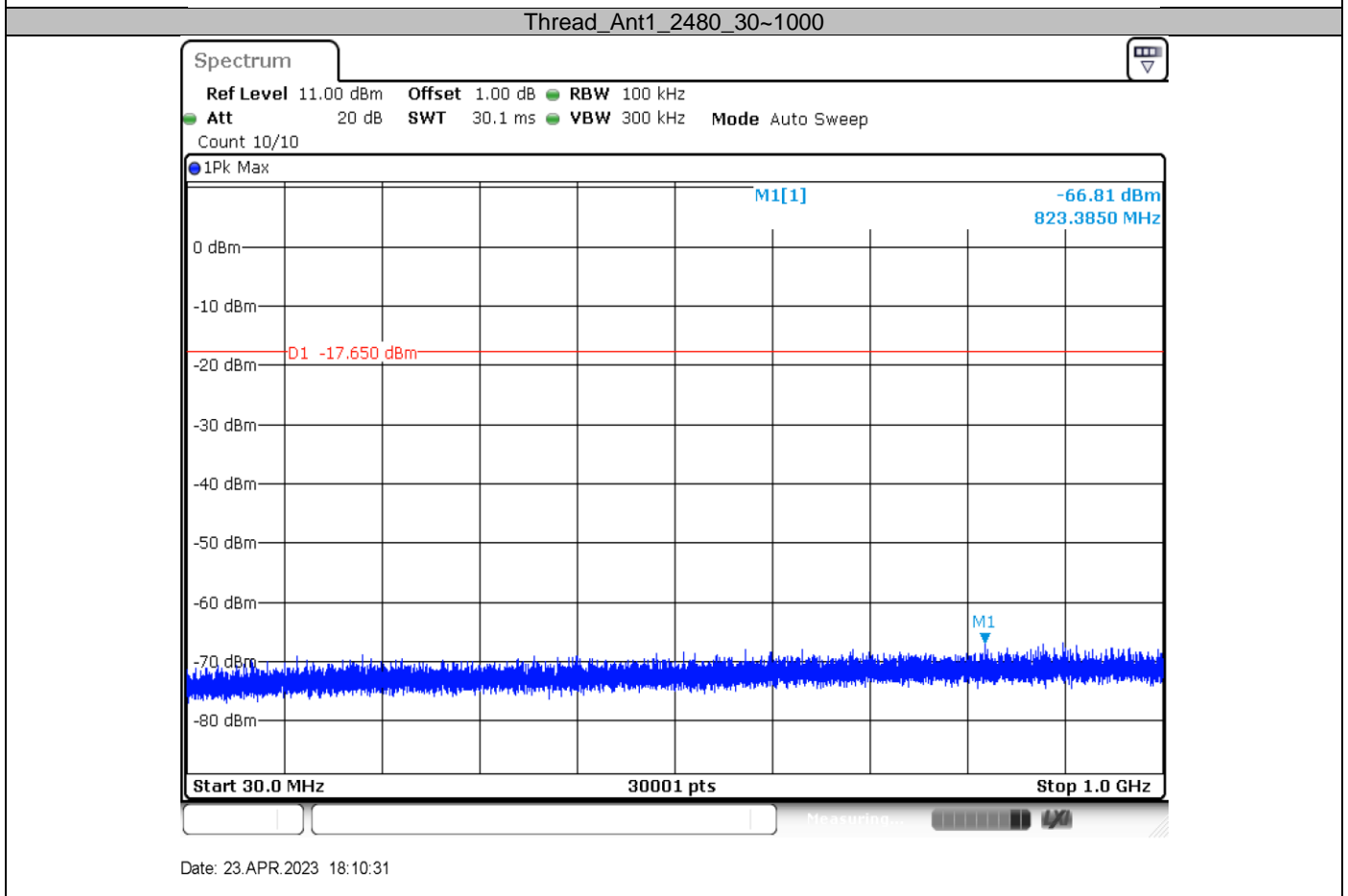
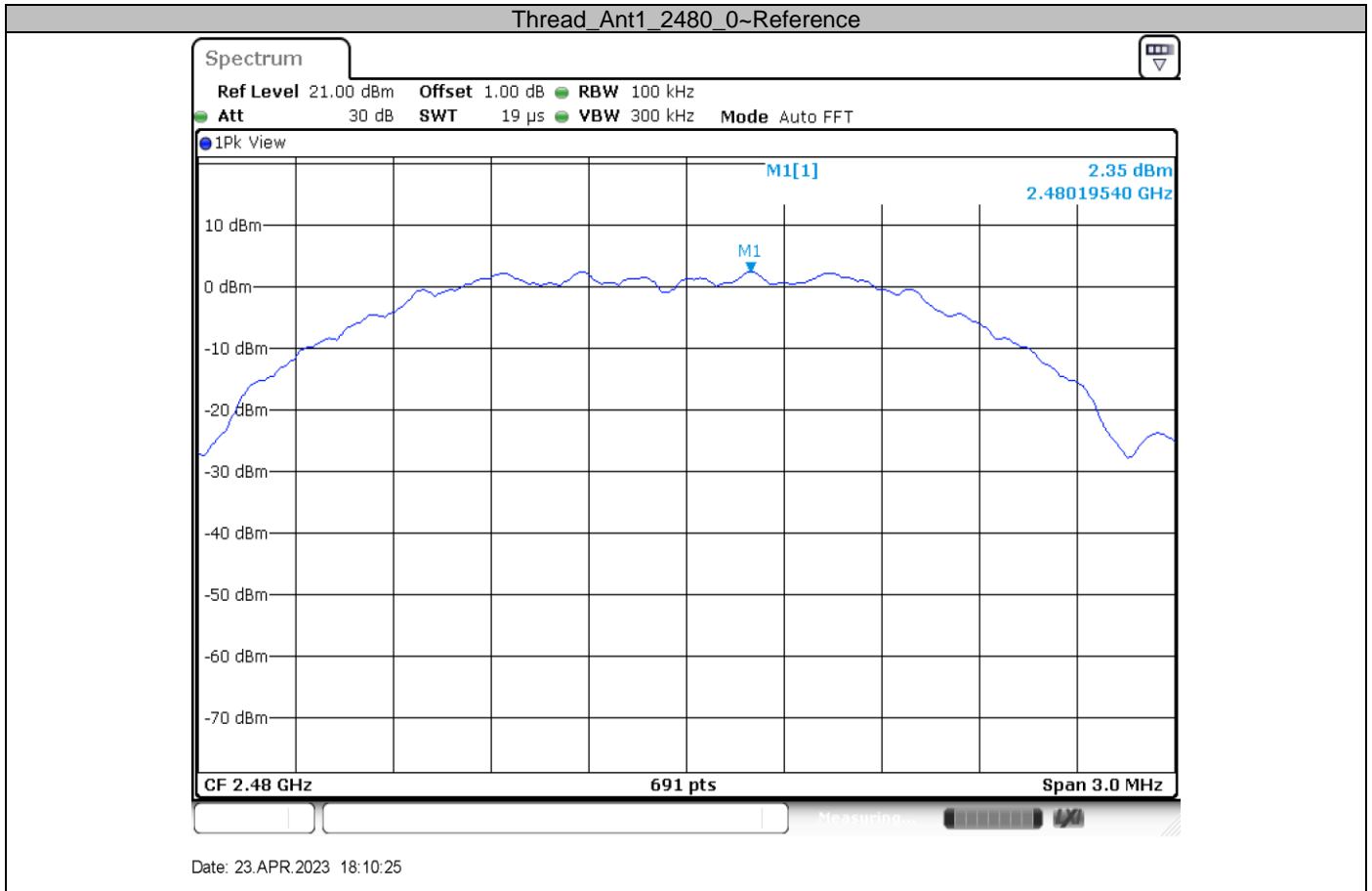



Thread\_Ant1\_2480\_1000~26500

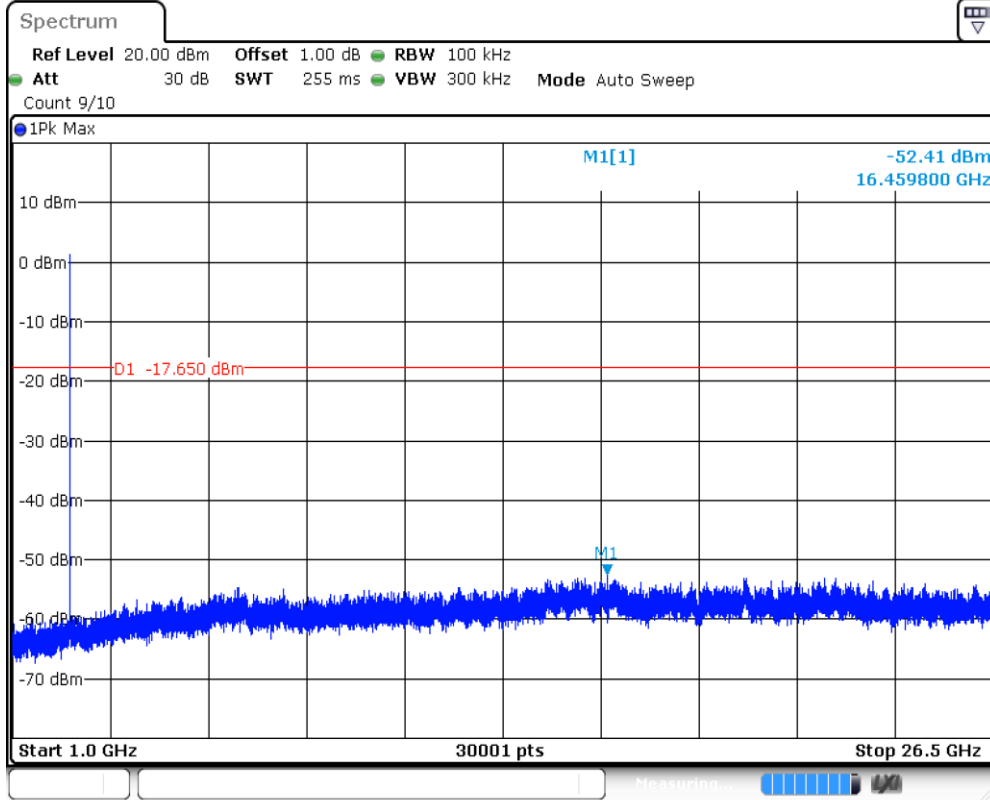

Date: 23.APR.2023 18:10:39

## 9.6 Band edge

### Test Method

1. The RF output of EUT was connected to the spectrum analyzer by RF cable. The path loss was compensated to the results for each measurement.
2. Set to the maximum power setting, the instrument center frequency is set to the nominal EUT channel center frequency enable the EUT transmit continuously.
3. Use the following spectrum analyzer settings:  
Span = wide enough to capture the peak level of the in-band emission and all spurious  
RBW = 100 kHz, VBW≥3RBW, Sweep = auto, Detector function = peak, Trace = max hold
4. Allow the trace to stabilize, use the peak and delta measurement to record the result.
5. The level displayed must comply with the limit specified in this Section.
6. Repeat above procedures until all frequencies measured were complete and submit all the plots.

### Limit:

In any 100 kHz bandwidth outside the frequency band in which the spread spectrum or digitally modulated device is operating, the RF power that is produced shall be at least 20 dB below that in the 100 kHz bandwidth within the band that contains the highest level of the desired power, based on either an RF conducted or a radiated measurement, provided that the transmitter demonstrates compliance with the peak conducted power limits. If the transmitter complies with the conducted power limits based on the use of RMS averaging over a time interval, as permitted under § 15.247(b)(3), the attenuation required shall be 30 dB instead of 20 dB.

Frequency Range MHz	Limit (dBc)
30-25000	-20

### Test result

TestMode	Antenna	ChName	Channel	RefLevel	Result	Limit	Verdict
Thread	Ant1	Low	2405	2.06	-52.76	<=-17.94	PASS
		High	2480	2.46	-47.95	<=-17.54	PASS

Test Graphs

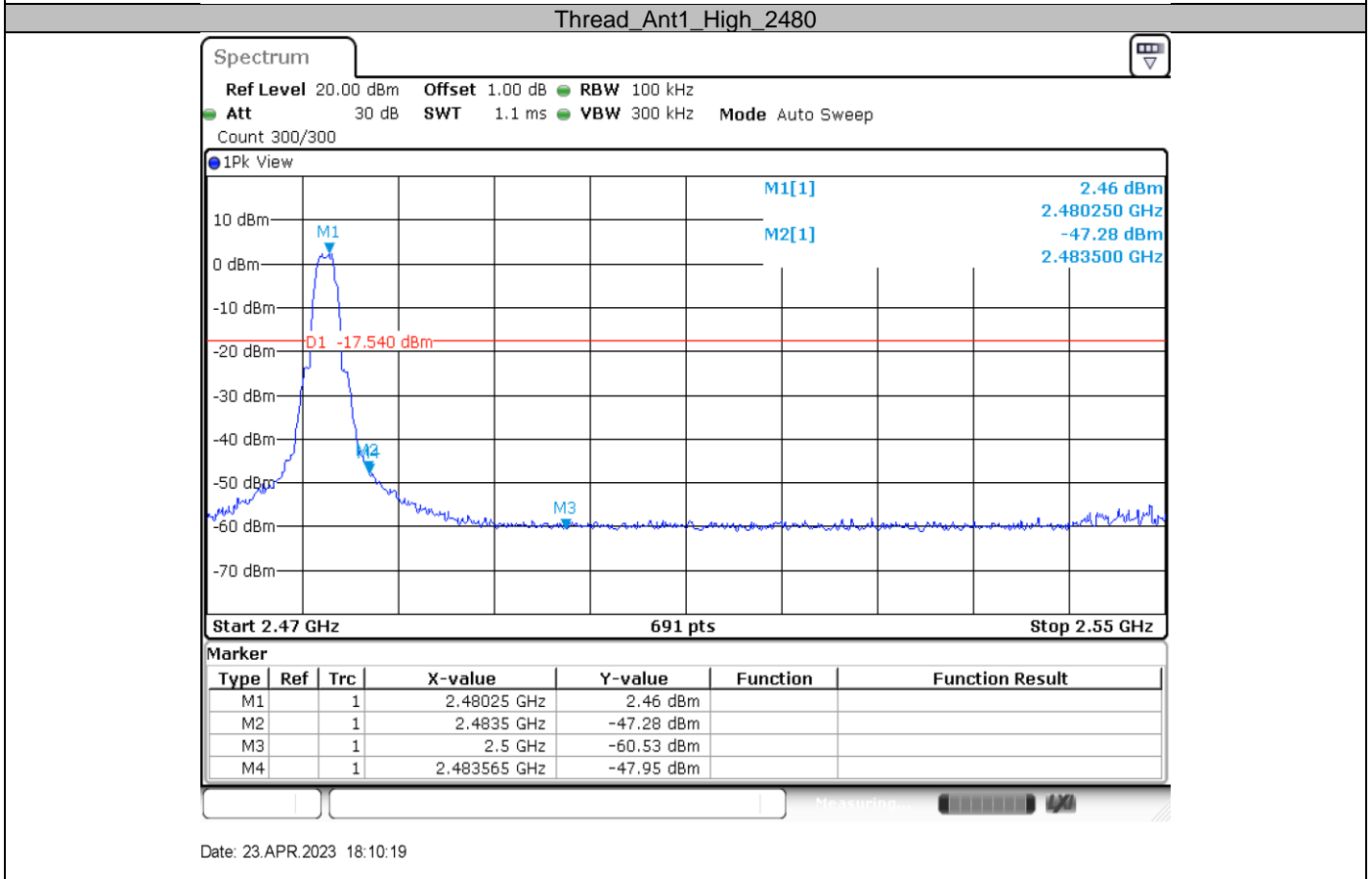
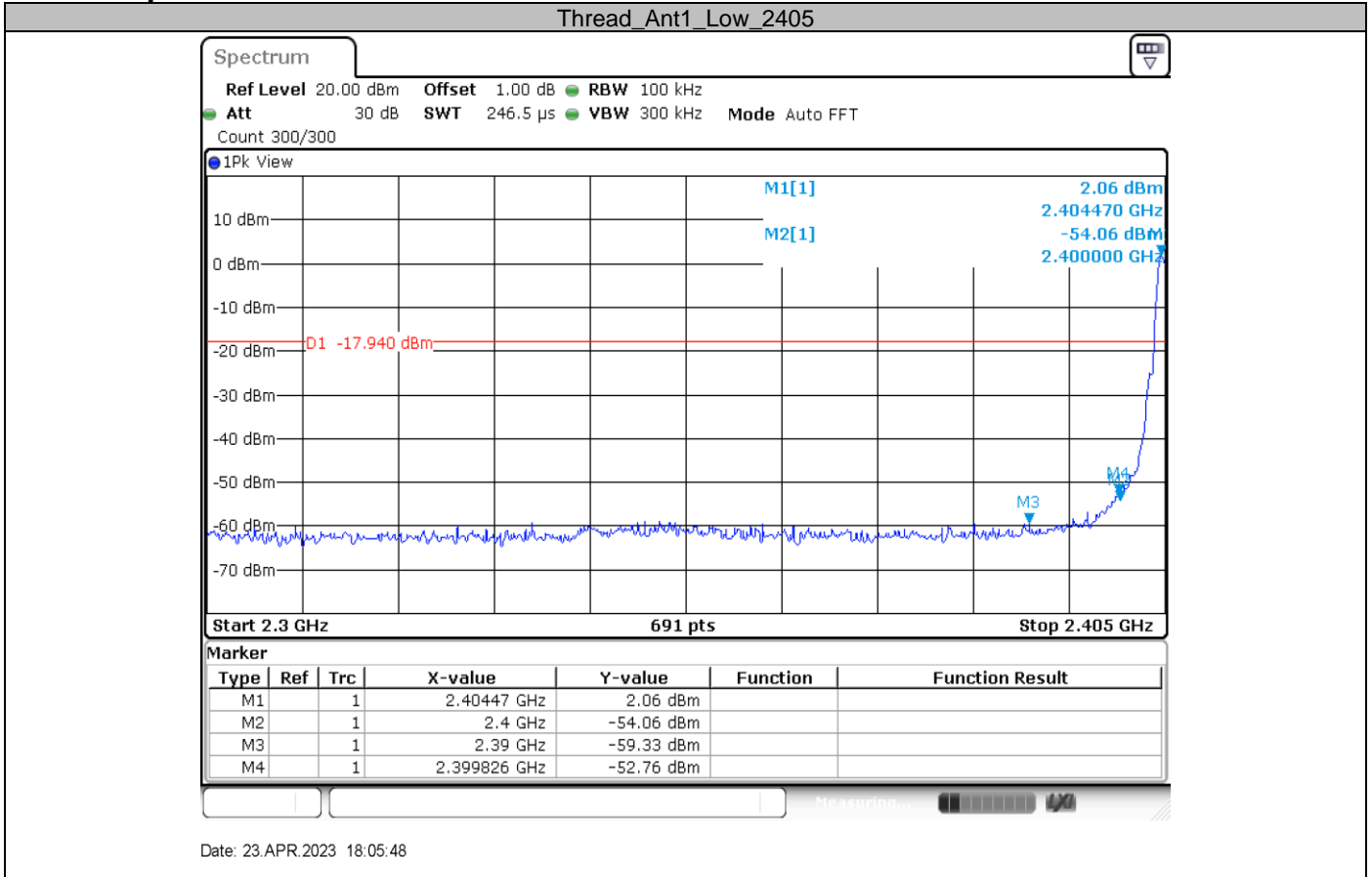

## 9.7 Spurious radiated emissions for transmitter

### Test Method

- 1: The EUT was placed on a turn table which is 1.5m above ground plane for above 1GHz and 0.8m above ground for below 1GHz at 3 meter chamber room for test. The table was rotated 360 degrees to determine the position of the highest radiation.
- 2: The EUT was set 3 meters away from the interference – receiving antenna, which was mounted on the top of a variable – height antenna tower.
- 3: The height of antenna is varied from one meter to four meters above the ground to determine the maximum value of the field strength. Both horizontal and vertical polarizations of the antenna are set to make the measurement.
- 4: For each suspected emission, the EUT was arranged to its worst case and then the antenna was tuned to heights from 1 meter to 4 meters and the rotatable table was turned from 0 degrees to 360 degrees to find the maximum reading.
- 5: Use the following spectrum analyzer settings According to C63.10:

For Below 1GHz

Use the following spectrum analyzer settings:

Span = wide enough to capture the peak level of the in-band emission and all spurious  
 RBW = 100 kHz to 120kHz, VBW ≥ RBW for peak measurement, Sweep = auto, Detector function = peak, Trace = max hold.

For Peak unwanted emissions Above 1GHz:

Span = wide enough to capture the peak level of the in-band emission and all spurious  
 RBW = 1MHz, VBW ≥ RBW for peak measurement, Sweep = auto, Detector function = peak, Trace = max hold.

Procedures for average unwanted emissions measurements above 1000 MHz

- a) RBW = 1MHz.
- b) VBW \ [3 × RBW].
- c) Detector = RMS (power averaging), if [span / (# of points in sweep)] \ RBW / 2. Satisfying this condition can require increasing the number of points in the sweep or reducing the span. If the condition is not satisfied, then the detector mode shall be set to peak.
- d) Averaging type = power (i.e., rms) (As an alternative, the detector and averaging type may be set for linear voltage averaging. Some instruments require linear display mode to use linear voltage averaging. Log or dB averaging shall not be used.)
- e) Sweep time = auto.
- f) Perform a trace average of at least 100 traces if the transmission is continuous. If the transmission is not continuous, then the number of traces shall be increased by a factor of 1 / D, where D is the duty cycle. For example, with 50% duty cycle, at least 200 traces shall be averaged. (If a specific emission is demonstrated to be continuous—i.e., 100% duty cycle—then rather than turning ON and OFF with the transmit cycle, at least 100 traces shall be averaged.)
- g) If tests are performed with the EUT transmitting at a duty cycle less than 98%, then a correction factor shall be added to the measurement results prior to comparing with the emission limit, to compute the emission level that would have been measured had the test been performed at 100% duty cycle. The correction factor is computed as follows:
  - 1) If power averaging (rms) mode was used in the preceding step e), then the correction factor is [10 log (1 / D)], where D is the duty cycle. For example, if the transmit duty cycle was 50%, then 3 dB shall be added to the measured emission levels.
  - 2) If linear voltage averaging mode was used in the preceding step e), then the correction

factor is  $[20 \log (1 / D)]$ , where D is the duty cycle. For example, if the transmit duty cycle was 50%, then 6 dB shall be added to the measured emission levels.

3) If a specific emission is demonstrated to be continuous (100% duty cycle) rather than turning ON and OFF with the transmit cycle, then no duty cycle correction is required for that emission.

## Limit

In any 100 kHz bandwidth outside the frequency band in which the spread spectrum or digitally modulated device is operating, the RF power that is produced shall be at least 20 dB below that in the 100 kHz bandwidth within the band that contains the highest level of the desired power, based on either an RF conducted or a radiated measurement, provided that the transmitter demonstrates compliance with the peak conducted power limits. If the transmitter complies with the conducted power limits based on the use of RMS averaging over a time interval, as permitted under § 15.247(b)(3) and RSS 247 section 5.4(d), the attenuation required shall be 30 dB instead of 20 dB. Attenuation below the general field strength limits specified in § 15.209(a) and RSS-Gen is not required. In addition, radiated emissions which fall in the restricted bands, as defined in § 15.205(a) and RSS-Gen section 8.9, must also comply with the radiated emission limits specified in § 15.209(a) and RSS-Gen section 8.10.

Frequency MHz	Field Strength uV/m	Field Strength dBµV/m	Detector
30-88	100	40	QP
88-216	150	43.5	QP
216-960	200	46	QP
960-1000	500	54	QP
Above 1000	500	54	AV
Above 1000	5000	74	PK



## Spurious radiated emissions for transmitter

According to C63.10, if the peak (or quasi-peak) measured value complies with the average limit, it is unnecessary to perform an average measurement, so AV emission value did not show in below table if the peak value complies with average limit.

### Transmitting spurious emission test result as below:

#### 2405MHz (30MHz – 1GHz) (Worst Case)

Emission Type	Frequency MHz	Emission Level dBuV/m	Polarization	Limit dBµV/m	Margin dB	Detector	Corr. dB	Result
Spurious	212.988733	36.80	Horizontal	40.00	3.20	QP	16.00	Pass
Spurious	54.303889	33.59	Vertical	40.00	6.41	Peak	17.94	Pass

#### 2405MHz (Above 1GHz)

Emission Type	Frequency MHz	Emission Level dBuV/m	Polarization	Limit dBµV/m	Margin dB	Detector	Corr. dB/m	Result
Harmonic	7206.500000	52.50	Horizontal	74.00	21.50	PK	8.92	Pass
Harmonic	7206.500000	52.20	Horizontal	54.00	1.80	AV	8.92	Pass
Spurious	4828.000000*	49.55	Vertical	74.00	24.45	PK	5.68	Pass

#### 2440MHz (Above 1GHz)

Emission Type	Frequency MHz	Emission Level dBuV/m	Polarization	Limit dBµV/m	Margin dB	Detector	Corr. dB/m	Result
Harmonic	4881.500000*	51.26	Horizontal	74.00	22.74	PK	6.07	Pass
Harmonic	4881.500000*	50.73	Horizontal	54.00	3.27	AV	6.07	Pass
Harmonic	7322.000000*	52.79	Horizontal	74.00	21.21	PK	8.78	Pass
Harmonic	7322.000000*	51.87	Horizontal	54.00	2.13	AV	8.78	Pass
Spurious	3984.500000*	47.26	Vertical	74.00	26.74	PK	2.86	Pass

#### 2480MHz (Above 1GHz)

Emission Type	Frequency MHz	Emission Level dBuV/m	Polarization	Limit dBµV/m	Margin dB	Detector	Corr. dB/m	Result
Harmonic	7441.500000*	52.29	Horizontal	74.00	21.71	PK	8.94	Pass
Harmonic	7441.500000*	51.76	Horizontal	54.00	2.24	AV	8.94	Pass
Spurious	3852.500000*	49.02	Vertical	74.00	24.98	PK	2.76	Pass

#### Remark:

- (1) "\*" means the emission(s) appear within the restrict bands shall follow the requirement of section 15.205.
- (2) Data of measurement within frequency range 9kHz-30MHz, 18-26GHz are the noise floor or attenuated more than 20dB below the permissible limits or the field strength is too small to be measured, so test data does not present in this report.
- (3) Data of measurement within this frequency range shown "--" in the table above means the reading of emissions are the noise floor or attenuated more than 10dB below the permissible limits or the field strength is too small to be measured.
- (4) Level=Reading Level + Correction Factor  
 Above 1GHz: Corrector factor = Antenna Factor + Cable Loss- Amplifier Gain  
 Below 1GHz: Corrector factor = Antenna Factor + Cable Loss  
 (The Reading Level is recorded by software which is not shown in the sheet)

## 10 Test Equipment List

### Radiated Emission Test 1# Test

DESCRIPTION	MANUFACTURER	MODEL NO.	EQUIPMENT ID	SERIAL NO.	CAL INTERVAL (YEAR)	CAL. DUE DATE
EMI Test Receiver	Rohde & Schwarz	ESR 7	68-4-74-19-001	102176	1	2023-5-27
Trilog Super Broadband Test Antenna	Schwarzbeck	VULB 9163	68-4-80-14-002	707	1	2023-7-12
Loop Antenna	Rohde & Schwarz	HFH2-Z2	68-4-80-14-006	100398	1	2023-8-17
Pre-amplifier	Rohde & Schwarz	SCU 18	68-4-29-14-001	102230	1	2023-5-28
Attenuator	Mini-circuits	UNAT-6+	68-4-81-21-001	15542	1	2023-5-27
3m Semi-anechoic chamber	TDK	SAC-3 #1	68-4-90-14-001	----	2	2023-5-28
Test software	Rohde & Schwarz	EMC32	68-4-90-14-001-A10	Version10.35.02	N/A	N/A

### Radiated Emission 2# Test

DESCRIPTION	MANUFACTURER	MODEL NO.	EQUIPMENT ID	SERIAL NO.	CAL INTERVAL (YEAR)	CAL. DUE DATE
EMI Test Receiver	Rohde & Schwarz	ESR 26	68-4-74-14-002	101269	1	2023-5-28
Wave Guide Antenna	ETS	3117	68-4-80-19-001	00218954	1	2023-5-9
Pre-amplifier	Rohde & Schwarz	SCU 18F	68-4-29-19-001	100745	1	2023-5-28
Pre-amplifier	Rohde & Schwarz	SCU 18F	68-4-29-19-002	100746	1	2023-5-28
Sideband Horn Antenna	Q-PAR	QWH-SL-18-40-K-SG	68-4-80-14-008	12827	1	2023-7-12
Pre-amplifier	Rohde & Schwarz	SCU 40A	68-4-29-14-002	100432	1	2023-7-27
Attenuator	Mini-circuits	UNAT-6+	68-4-81-21-002	15542	1	2023-5-27
3m Semi-anechoic chamber	TDK	SAC-3 #2	68-4-90-19-006	----	2	2023-5-28
Test software	Rohde & Schwarz	EMC32	68-4-90-19-006-A01	Version10.35.02	N/A	N/A

### Conducted Emission 2# Test

DESCRIPTION	MANUFACTURER	MODEL NO.	EQUIPMENT ID	SERIAL NO.	CAL INTERVAL (YEAR)	CAL. DUE DATE
EMI Test Receiver	Rohde & Schwarz	ESR 3	68-4-74-19-002	102590	1	2023-5-27
LISN	Rohde & Schwarz	ENV216	68-4-87-19-001	102472	1	2023-5-27
Attenuator	Shanghai Huaxiang	TS2-26-3	68-4-81-16-003	080928189	1	2023-5-27
Test software	Rohde & Schwarz	EMC32	68-4-90-19-005-A01	Version10.35.02	N/A	N/A
Shielding Room	TDK	CSR #2	68-4-90-19-005	----	3	2025-10-15

### RF Conducted Test

DESCRIPTION	MANUFACTURER	MODEL NO.	EQUIPMENT ID	SERIAL NO.	CAL INTERVAL (YEAR)	CAL. DUE DATE
Signal Analyzer	Rohde & Schwarz	FSV40	68-4-74-14-004	101030	1	2023-5-27
RF Switch Module	Rohde & Schwarz	OSP120/OSP-B157	68-4-93-14-003	101226/100851	1	2023-5-27
Power Splitter	Weinschel	1580	68-4-85-14-001	SC319	1	2023-5-28
Test software	Rohde & Schwarz	EMC32	68-4-48-14-003-A10	Version 10.60.10	N/A	N/A
Test software	Tonscend	System for BT/WIFI	68-4-74-14-006-A13	Version 2.6.77.0518	N/A	N/A
Shielding Room	TDK	TS8997	68-4-90-19-003	----	3	2022-11-07

## 11 System Measurement Uncertainty

For a 95% confidence level, the measurement expanded uncertainties for defined systems, in accordance with the recommendations of ISO 17025 were:

System Measurement Uncertainty	
Test Items	Extended Uncertainty
Uncertainty for Conducted Emission in new shielding room (68-4-90-19-005) 150kHz-30MHz (for test using AMN ENV216)	3.33dB
Uncertainty for Radiated Emission in 3m chamber (68-4-90-14-001) 30MHz-1000MHz	Horizontal: 4.64dB; Vertical: 4.79dB;
Uncertainty for Radiated Emission in new 3m chamber (68-4-90-19-006) 1000MHz-18000MHz	Horizontal: 5.08dB; Vertical: 5.09dB;
Uncertainty for Radiated Emission in new 3m chamber (68-4-90-19-006) 18GHz-40GHz	Horizontal: 3.14dB; Vertical: 3.12dB;
Uncertainty for Conducted RF test with TS 8997	RF Power Conducted: 1.31dB Frequency test involved: 0.6×10 <sup>-8</sup> or 1%

### Measurement Uncertainty Decision Rule

Determination of conformity with the specification limits is based on the decision rule according to IEC Guide 115: 2021, clause 4.4.3 and 4.5.1.

End of Report