

FCC Test Firm Designation Number: FR0014
Industry Canada Test Firm Number: Site# 9545A-1 / 9545A-2

Matériel testé :
Equipment under test:

SEVENHUGS / Smart Remote SR1A (WIFI mode)
(Trademark / Marketing name or product reference)

Client / Demandeur:
Customer / Applicant : **Sevenhugs**
Stephane Jaubertou
29 bd Romain Rolland
75014 Paris - France

Fabricant :
Manufacturer: **Sevenhugs**
29 bd Romain Rolland
75014 Paris - France

Numéro d'affaire :
Work number : 12114

Référence de la proposition :
Proposal number: 032017-22416

Date de l'essai :
Date of test: Du 4 au 8 juin 2018
June 4th to 8th, 2018

Objectif des essais :
Test purpose: EMC qualification accordingly to following standards:
- CFR 47, FCC Part 15, Subpart B & C
(Chapter 15.247 - Operation within the bands 902–928 MHz, 2400–2483.5 MHz, and 5725–5850 MHz)
- Industry Canada ICES-003 Issue 6 & RSS-247, Issue 2
(Digital Transmission Systems Operating in the Bands 2400-2483.5 MHz)

Lieu du test:
Test location: SMEE, Rue de Taille
38500 VOIRON - France

Test réalisé par :
Test realized by: Laurent CHAPUS

Conclusion :
Conclusion: L'équipement satisfait aux prescriptions des normes citées en référence.
The appliance complies with requirements of above mentioned standards.

Ed.	Date	Modifications Pages /	Written by : Visa	Approved by: Visa
1	August 21 th , 2018	Initial Edition	Laurent Chapus	Régis ANCEL

La copie de ce document n'est permise que sous sa forme intégrale. Ce document est le résultat d'essais effectués sur un échantillon. Il ne préjuge pas de la conformité de l'ensemble des produits fabriqués à l'objet essayé.
This document shall not be reproduced, except in full. This document contains results related only to the item tested. It does not imply the conformity of the whole production to the item tested.



Accréditation
N° 1-6356
Portée disponible sur :
Scope available on :
www.cofrac.fr

COORDONNEES

SMEE
Rue de Taille – ZI Des Blanchisseries
38500 VOIRON - France

TEL : 04 76 65 76 50
FAX : 04 76 66 18 30

SAS au capital de 50 000 € / RC Grenoble B534 796 453 / SIRET 534 796 453 00015 / code APE 7490B / n° TVA : FR 59 534 796 453

Contents

1. NORMATIVES REFERENCES	3
2. TEST SYNTHESIS	4
3. EQUIPMENT UNDER TEST (EUT).....	5
4. TEST CONDITIONS.....	5
5. MODIFICATIONS OF THE EUT.....	6
6. SPECIAL ACCESSORY	6
7. CONDUCTED EMISSION MEASUREMENT (150KHZ-30MHZ).....	7
8. RADIATED EMISSION MEASUREMENT (30MHZ-5GHZ).....	10
9. 6DB BANDWIDTH.....	16
10. MAXIMUM CONDUCTED (AVERAGE) OUTPUT POWER.....	21
11. MAXIMUM POWER SPECTRAL DENSITY LEVEL IN THE FUNDAMENTAL EMISSION	25
12. UNWANTED EMISSIONS IN NON-RESTRICTED FREQUENCY BANDS.....	32
13. UNWANTED EMISSIONS IN RESTRICTED FREQUENCY BANDS.....	37
14. OCCUPIED BANDWIDTH (99%).....	56

1. Normatives References

FCC qualification according to:		
Standards	Applied	Title
ANSI C63.4 (2014)	X	American National Standard for Methods of Measurement of Radio-Noise Emissions from Low-Voltage Electrical and Electronic Equipment in the Range of 9 kHz to 40 GHz.
ANSI C63.10 (2013)	X	American National Standard for Testing Unlicensed Wireless Devices
CFR47, Part 15	X	Telecommunication – Federal Communication Commission – Radio frequency devices, Sections 15.107 / 15.109 / 15.207 / 15.209 / 15.247

Industry Canada qualification according to:		
Standards	Applied	Title
ICES-003 (Issue 6/2016)	X	Information Technology Equipment (ITE) – Limits and methods of measurement
RSS-Gen (Issue 5/2018)	X	General Requirements and Information for the Certification of Radio Apparatus
RSS-247 (Issue2/2017)	X	Digital Transmission Systems (DTSs), Frequency Hopping Systems (FHSs) and Licence-Exempt Local Area Network (LE-LAN) Devices

Note: Following guidance are used

- DTS Measurement Guidance 558074 D01 v04
- Determining ERP and EIRP Guidance 412172 D01 v01r01

Deviation from standard: None

2. Test synthesis

TEST	Paragraph number FCC Part 15 / IC RSS-247 / RSS-GEN	Spec. FCC Part 15 / IC RSS-247 / RSS-GEN	RESULTS (comments)
Conducted emissions test	15.207 (a) RSS-Gen § 8.8	Table 15.107 (a) Table 4 / RSS-Gen	PASS
Radiated emission test	15.209 (a) ICES-003	Table 15.209 (a) Table 5 & 7 , § 6.2	PASS [1]
6dB Bandwidth	15.247 (a) (2) RSS-247 § 5.2 (a)	At least 500kHz	PASS
Maximum Conducted Output Power (Average)	15.247 (b) (3) RSS-247 § 5.4 (d)	1W max / 30dBm (Conducted) 4W max / 36dBm (EIRP)	PASS
Maximum Power Spectral Density	15.247 (e) RSS-247 § 5.2 (b)	8dBm in a 3kHz band segment	PASS
Unwanted emissions into Non Restricted Frequency Bands	15.247 (d) / RSS-247 § 5.5	-30dBc in any 100kHz outside frequency band.	PASS
Unwanted emissions into Restricted Frequency Bands	15.209 (a) / 15.247 (d) / 15.205 (a) RSS-GEN § 7.1, §8.9, § 8.10 / RSS-247 § 3.3	<u>Measure at 300m</u> 9-490kHz: 2400µV/m/F(kHz) <u>Measure at 30m</u> 0.490-1.705: 24000µV/m/F(kHz) 1.705-30MHz: 30µV/m <u>Measure at 3m</u> 30MHz-88MHz : 40 dBµV/m 88MHz-216MHz : 43.5 dBµV/m 216MHz-960MHz : 46.0 dBµV/m Above 960MHz : 54.0 dBµV/m	PASS
Occupied Bandwidth	RSS-GEN § 6.7	BW at 99%	PASS

N/A: Not Applicable

[1]: For battery charging mode with all non-RF functions.

- General conclusion:**

Measures and tests performed on the sample of the product *SEVENHUGS Smart Remote SR1A*, in configuration and description presented in this test report, show compliance with standards FCC CFR 47, PART 15, Subpart B & C and Industry Canada ICES-003, RSS-Gen & RSS-247.

3. Equipment Under Test (EUT)

Nom /
Identification

SEVENGUGS Smart Remote SR1A

Sn: PP3

FCC ID:
IC:
Model:

FCC ID: 2AEVC-SR1A
IC: 20292-SR1A
SR1A

Alimentation /
Power supply

5V DC from power adapter.
AC/DC power adapter: Dong Guan City GangQi Electronic Co
Model:GQ06-050120-AX
Input:100-240 V -50/60 Hz 0.3 Amax
Output:5V/1.2A (1.8m cable)

Auxiliaires /
Auxiliaries

Charging base CB1A / Sevenhugs

Entrées-Sorties /
Input / Output

	Câbles pour essai / Cables for test	Blindé / Shielded	Prévu pour >3m / Intended for >3m
AC Mains *	2 wires / 1m	No	Mains
DC cable *	2 wires / 1.8m	No	No

*: Power supply of charging base. No cable on Remote.

Version programme /
Firmware version

Certification_v10.1

Mode de fonctionnement /
Running mode

The tested sample is able to:

- Transmit a carrier frequency on low, middle and high channels (WIFI 802.11 b/g/n) without battery charging mode (Standalone mode)
- Transmit a carrier frequency on low, middle and high channels (WIFI 802.11 b/g/n) with battery charging
- Battery charging with all others non-RF functions (IR, Sound, Vibrator, MEMS, LCD tests)

Programme de test /
Test program /

None

Fréquence max interne EST /
Max internal EUT frequency

1GHz (Except RF frequency)

Information sur l'équipement /
Equipment information

WIFI 802.11 Mode b/g/n (20MHz BW)
- Modulation: 802.11b: DSSS with BPSK
- Modulation: 802.11g/n: OFDM with BPSK, QPSK, QAM
- Operating frequency: 2412-2462MHz (Channel 1 to 11)
- Number of channel used: 11 / Spaced 5MHz
- Antenna type: Internal (PCB trace, peak gain 6.4dBi)
- Emission band: 2400-2483.5 MHz (ISM frequency band)

4. Test conditions

Power supply voltage:
Equipment under test:

Internal battery Lipo 3.7V (Remote)
5V DC from external power adapter (For charging base)

Auxiliaries:

230V/50Hz (Radiated emission)
110V/60Hz (Conducted emission)

5. Modifications of the EUT

None

6. Special accessory

None

7. Conducted Emission Measurement (150kHz-30MHz)

TEST: Limits for conducted disturbance 150kHz – 30MHz				Verdict	
<p>Method: The LISN is placed 0,8 m from the boundary of the unit under test and bonded to a ground reference plane. This distance was between the closest points of the AMN and the EUT. All other units of the EUT and associated equipment were at least 0,8 m from the AMN. All power was connected to the system through Artificial Mains Network (AMN). Conducted voltage measurements on lines were made at the output of the LISN. The EUT is 80cm above the ground reference plane and 40cm from the vertical ground plane. The AC power cable is 1m length.</p>				Pass	
Laboratory Parameters:		Required prior to the test		During the test	
Ambient Temperature		20 to 30 °C		23°C ± 2	
Relative Humidity		25 to 70 %		63% ± 5	
Fully configured sample scanned over the following frequency range		Frequency range on each side of line		Measurement Point	
		150kHz to 30MHz		AC input port (110V) Power adapter	
Limits					
Frequency (MHz)	Limit dB (µV)				
	Quasi-Peak	Result	Average	Result	
0.15 – 0.50	66 \ 56	PASS	56 \ 46	PASS	
0.50 - 5	56	PASS	46	PASS	
5 – 30	60	PASS	50	PASS	
Supplementary information:					
Test location: SMEE					
Test date: June 4 th , 2018. Tested by L. CHAPUS					
Power supply voltage: 5V from power adapter (AC mains 110V/60Hz)					

Test Equipment Used					
Description	Manufacturer	Model	Identifier	Cal. Date	Cal. Due
Attenuator / limiter	SMEE	ATT#2	ATT-171-010	2017/6	2018/6
Cable RF	Div	1m	CAB-101-021	2018/4	2019/4
LISN (50Ω / 50µH) (Meas.)	AFJ	LS16C	RSI-101-001	2017/6	2019/6
Measuring receiver	Rohde&Schwarz	ESRP	REC-151-002	2017/3	2019/3
EMC Software	NEXIO	BAT EMC V3.8	SOF-101-001	-	-
AC power supply	PACIFIC POWER	AMX-125	101-002	-	-

Test Setup for conducted emission

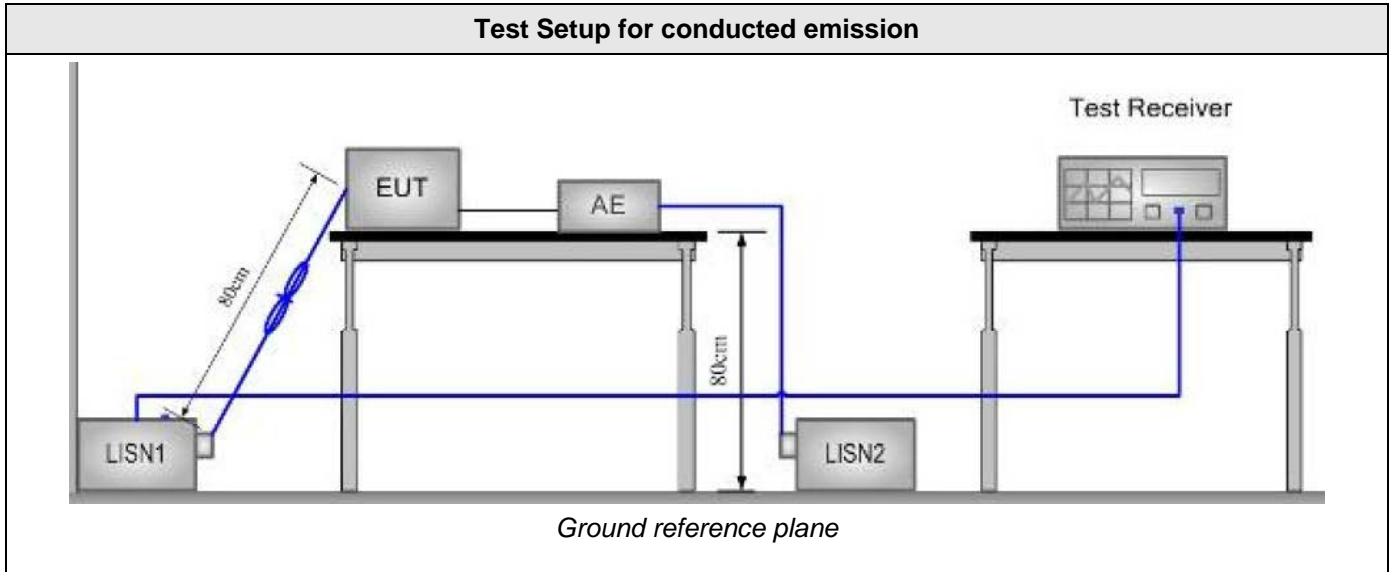

Tabulated Results for Mains Terminal Disturbance Voltage on AC port

FREQ (MHz)	Meas. PK (dBμV)	Mes. QP (dBμV)	LIMIT QP (dBμV)	Margin QP (dB)	Mes. AV (dBμV)	LIMIT AV (dBμV)	Margin AV (dB)	Line
0.154	55.9	51.3	65.8	-14.5	32.0	55.8	-23.8	L1
0.174	53.0	49.0	64.8	-15.8	29.2	54.8	-25.6	L1
0.198	49.5	44.3	63.7	-19.4	24.8	53.7	-28.9	L1
0.446	43.8	41.4	57.0	-15.6	31.1	47.0	-15.9	L1
0.926	37.7	31.6	56.0	-24.4	16.7	46.0	-29.3	L1
14.372	40.0	32.1	60.0	-27.9	18.2	50.0	-31.9	L1
0.154	54.4	50.3	65.8	-15.5	30.7	55.8	-25.1	Neutral
0.182	52.4	45.1	64.4	-19.3	24.0	54.4	-30.4	Neutral
0.234	47.3	40.7	62.3	-21.7	20.2	52.3	-32.1	Neutral
0.418	44.4	42.2	57.5	-15.3	30.2	47.5	-17.3	Neutral
13.168	33.7	24.3	60.0	-35.7	10.8	50.0	-39.2	Neutral
Frequency band investigated:			150kHz-30MHz					
RBW:			9kHz					
Voltage:			230V/50Hz					
Limit:			FCC Part 15.209 a) / RSS-Gen: Issue 5, §8.8 Table 4					
Final measurement detector:			Quasi-Peak and CISPR Average (AV)					
Wide Measurement Uncertainty:			± 3.5dB (k=2)					
RESULT:			PASS					
Measured value calculation:			<p>The measured value (level) is calculated by adding the Cable Factor, the Transient suppressor attenuation and LISN attenuation from the receiver amplitude reading. The basic equation is as follow:</p> $\text{Meas.} = \text{RA} + \text{CF} + \text{ATT}_{\text{TRAN}} + \text{ATT}_{\text{LISN}}$ <p>Where Meas. = Level (dBμV) RA = Receiver Amplitude CF = Cable Factor ATT_{TRAN} = Transient suppressor attenuation ATT_{LISN} = LISN attenuation</p> <p>Margin value = Emission level – Limit value (A negative margin shows compliance to limit)</p>					

Graphical representation of Conducted Disturbance Measurement (Peak and Average detection) AC port, Line L1 – Power adapter

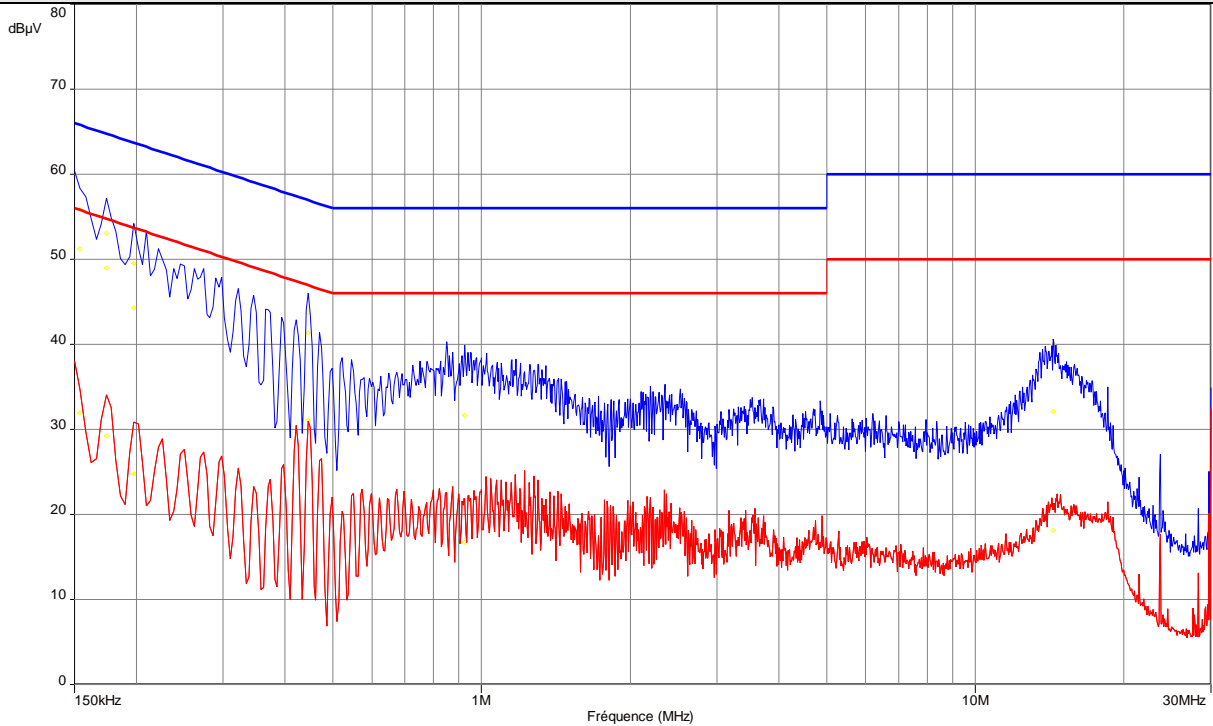

----: Peak ----: Average

Graphical representation of Conducted Disturbance Measurement (Peak and Average detection) AC port, Line Neutral – Power adapter

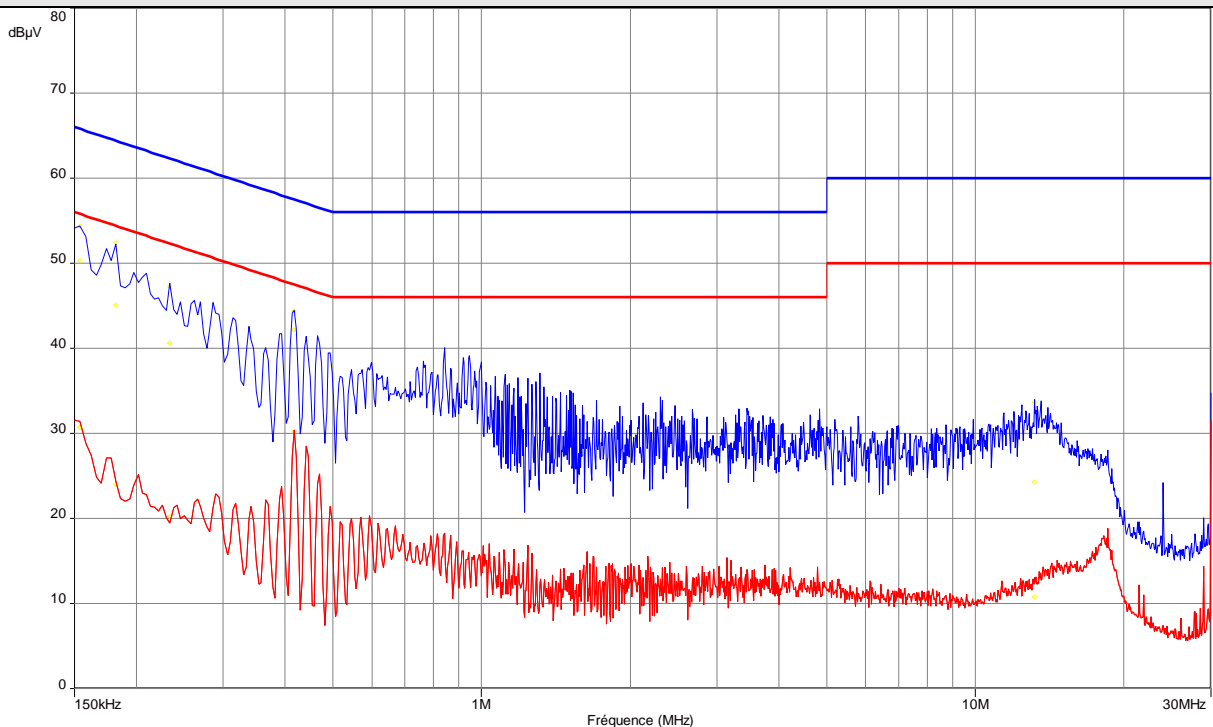

----: Peak ----: Average

8. Radiated Emission Measurement (30MHz-5GHz)

TEST: Limits for radiated disturbance 30 MHz – 5 GHz		Verdict
<p><u>Method:</u> Measurements were performed on a 3-meter Open Area Test Site (OATS) for frequency below 1GHz. The EUT was rotated 360° about its azimuth with the receive antenna located at various heights in horizontal and vertical polarities. Final measurements (Peak) were then performed by rotating the EUT on 360° and adjusting the receive antenna height from 1 to 4 m</p> <p>For frequency above 1GHz, final measurements were made at 3m in a Full Anechoic Chamber (FAC) that complies with ANSI C63.10. Measurements were performed at an antenna to EUT separation distance of 3 meter. The EUT was rotated 360° about its azimuth with the receive antenna in horizontal and vertical polarities.</p> <p>Three orthogonal axis measurements on EUT are performed to obtain the maximum peak field strength, with 60° rotation on each axis.(Clause 6.6.5 of ANSI C63.10).</p> <p>A pre-scan frequency identification of the EUT has been performed in full anechoic chamber. The measured radiated field of the EUT is performed (or corrected) at 3-meters of distance. Antenna is 1.25-meters high. The pre-characterization graphs are obtained in PEAK detection with 360° continuous rotation of the device under test.</p>		Pass
Laboratory Parameters:	Required prior to the test	During the test
Ambient Temperature	20 to 30 °C	22°C ± 2
Relative Humidity	25 to 70 %	64% ± 5
Fully configured sample scanned over the following frequency range	Frequency range on each side of line	Measurement Point
	30MHz – 5GHz	3 m measurement distance
Running mode	Battery Charging / All others non-RF functions	
Limits		
Frequency (MHz)	Limit at 3m (dBµV/m)	
	Level / Detector	Results
30 to 88	40.0 (QP)	Pass
88 to 216	43.5 (QP)	Pass
216 to 960	46.0 (QP)	Pass
960 to 1000	54.0 (QP)	Pass
Above 1GHz	54.0 (AV)	Pass
	74.0 (PK)	
Supplementary information:		
Test location: SMEE.		
Test date: June 4 th , 2018. Tested by L. CHAPUS		

Test Equipment Used					
Description	Manufacturer	Model	Identifier	Cal. Date	Cal. Due
Log-periodic antenna	TDK	PLP3003	ANT-101-001	2017/5	2019/5
Biconnic antenna	COM-POWER	AB- 900	ANT-101-003	2017/5	2019/5
Loop antenna	EMCO	6502	ANT-101-009	2017/8	2019/8
BiConiLog antenna	EMCO	3142B	ANT-101-010	2017/7	2019/7
Horn antenna	ETS-LINDGREN	3115	ANT-141-013	2014/3	2019/3
Spectrum analyzer	Rohde&Schwarz	FSV40	ASP-171-004	2017/5	2019/5
RF cable	Div	OATS/25m	CAB-101-017	2018/4	2019/4
RF cable	Pasternack RF	PE302-120	CAB-131-024	2018/4	2019/4
RF cable	HUBER+SUHNER	RG214U	CAB-141-026	2018/4	2019/4
RF cable	HUBER+SUHNER	RG214U	CAB-141-029	2018/4	2019/4
RF cable	HUBER+SUHNER	SF104	CAB-141-030	2018/4	2019/4
Anechoic chamber	COMTEST	214263	CAG-141-001	2017/6	2020/6
Antenna mast	Innco- Systems	MA4000EP	MAT-101-001	-	-
Turntable	Innco- Systems	DS1200S	PLA-101-001	-	-
Turntable	Innco- Systems	CT0800	PLA-141-001		
Pre-amplifier	PE	1524	PRE-101-002	2017/6	2018/6
Pre-amplifier	SMEE	18-40GHz	PRE-171-004	2017/12	2018/12
Measuring receiver	Rohde&Schwarz	ESRP	REC-151-003	2017/3	2019/3
OATS	Div	10m	SIT-101-001	2017/7	2020/7
EMC Software	NEXIO	BAT EMC V3.8	SOF-101-001	-	-

Test Setup for radiated emission

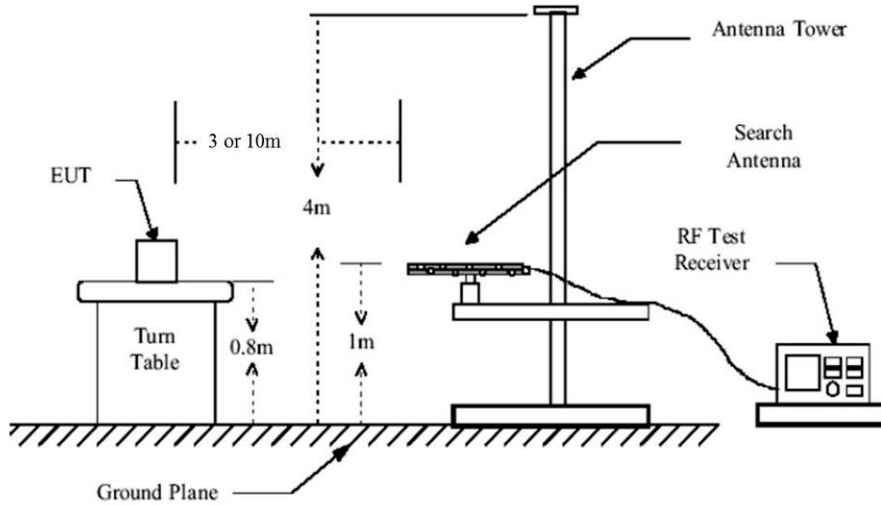

Test setup for 30-1000MHz

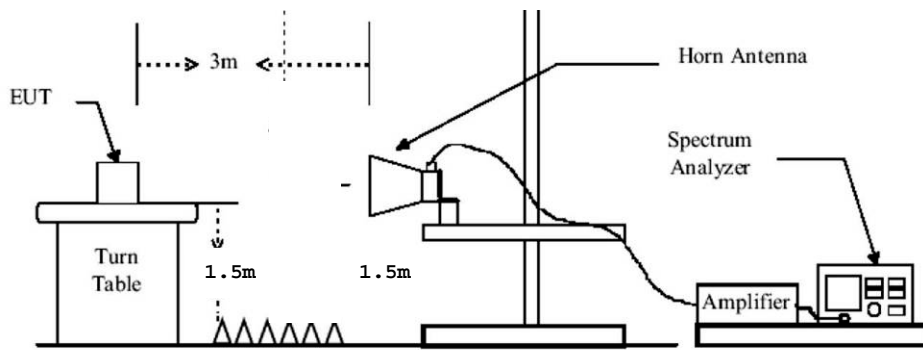

Test setup for 1-25GHz

Tabulated Results for Radiated Disturbance (3m measurement on Open Area Test Site, 30MHz-1GHz)

FREQ	Meter reading	Meter reading	Total Factor	Field level	Field level	Pol	Antenna height	Table angle	Limit	Margin
MHz	(QP) dB μ V	(Pk) dB μ V	dB	(QP) dB μ V/m	(Pk) dB μ V/m		cm	Degré	(QP) dB μ V/m	dB
63.586	19.8	25.6	9.9	29.7	35.5	V	100	170	40.0	-10.3
179.987	14.1	16.8	17.9	32.0	34.7	V	125	160	43.5	-11.5
419.960	20.9	23.8	20.2	41.1	44.0	V	155	45	46.0	-4.9

Supplementary information:

Frequency list measured on the Open Area Test Site is created with pre-scan results.

Frequency band investigated:	30MHz-1GHz
RBW:	120kHz
Measurement distance:	3m
Limit:	FCC Part 15.109 / 15.209 / ICES-003
Final measurement detector:	Quasi-Peak
Wide Measurement Uncertainty:	± 5.6 dB (k=2)
RESULT:	PASS
Field Strength Calculation:	<p>The field strength (level) is calculated by adding the Antenna Factor and Cable Factor, and subtracting the Amplifier Gain (if any) from the measured reading. The basic equation is as follow:</p> $FS = RA + AF + CF - AG$ <p>Where FS = Field Strength (Level) RA = Receiver Amplitude (Meter reading) AF = Antenna Factor CF = Cable Factor AG = Amplifier Gain</p> <p>Total factor (dB) is AF + CF – AG Margin value = Emission level – Limit value</p>

Graphical representation of Radiated Disturbance Measurement (Peak detection, Anechoic chamber pre-scan, 30MHz-1GHz / 3m)

Battery charging, with audio, IR, Mems, LCD

Horizontal polarization

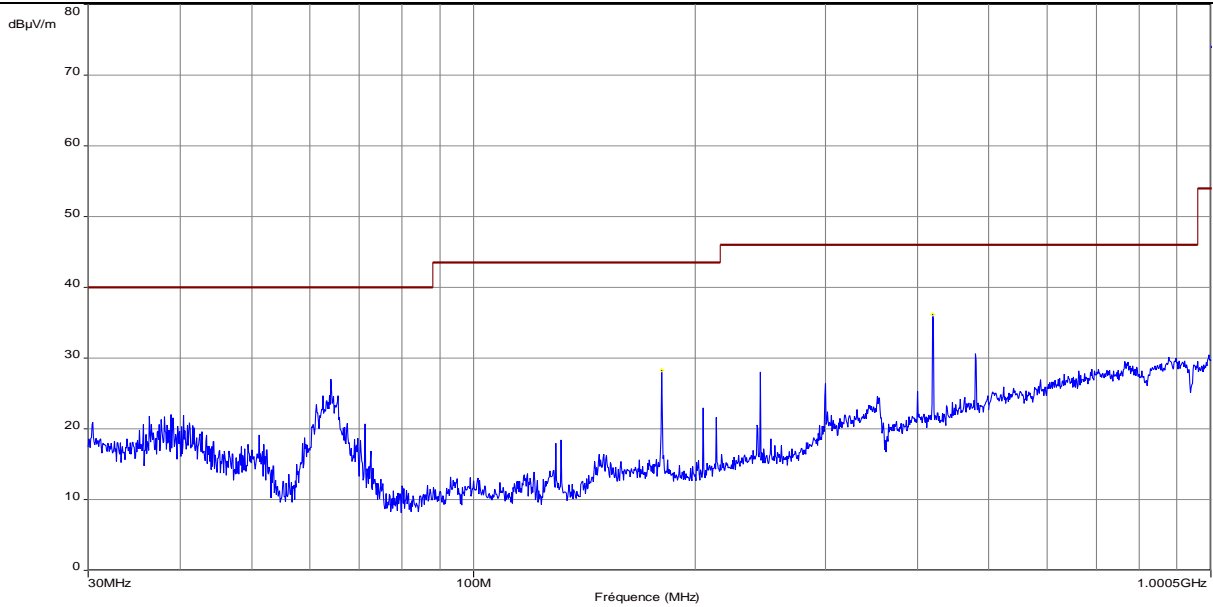

Vertical polarization

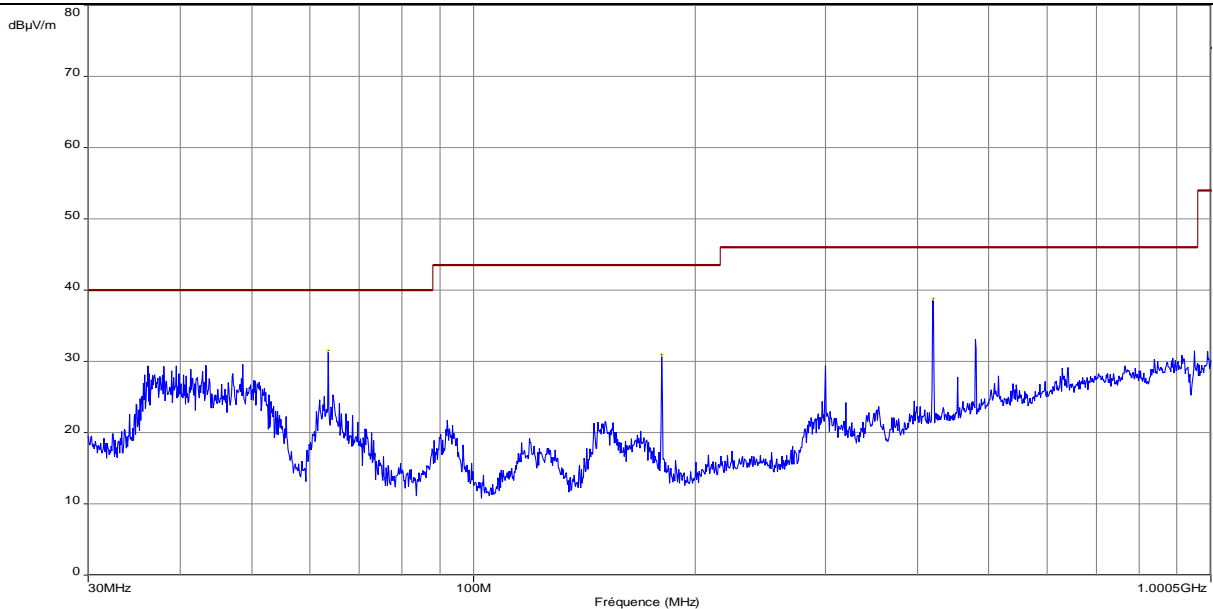

----- : Peak measure

----- : Class B limit (3m)

Note: Pre-scan graph only for identification purpose.

Marker List :

Frequency (MHz)	Peak Level (dBµV/m)	Limit (dBµV/m)	Polarization
419.959	36.2	46.5	Horizontal
63.558	32.1	40.0	Vertical
179.977	31.0	43.5	Vertical
419.959	38.9	46.0	Vertical

Graphical representation of Radiated Disturbance Measurement (Peak detection, Anechoic chamber pre-scan, 1GHz-6GHz / 3m)

Battery charging, with audio, IR, Mems, LCD

Horizontal polarization

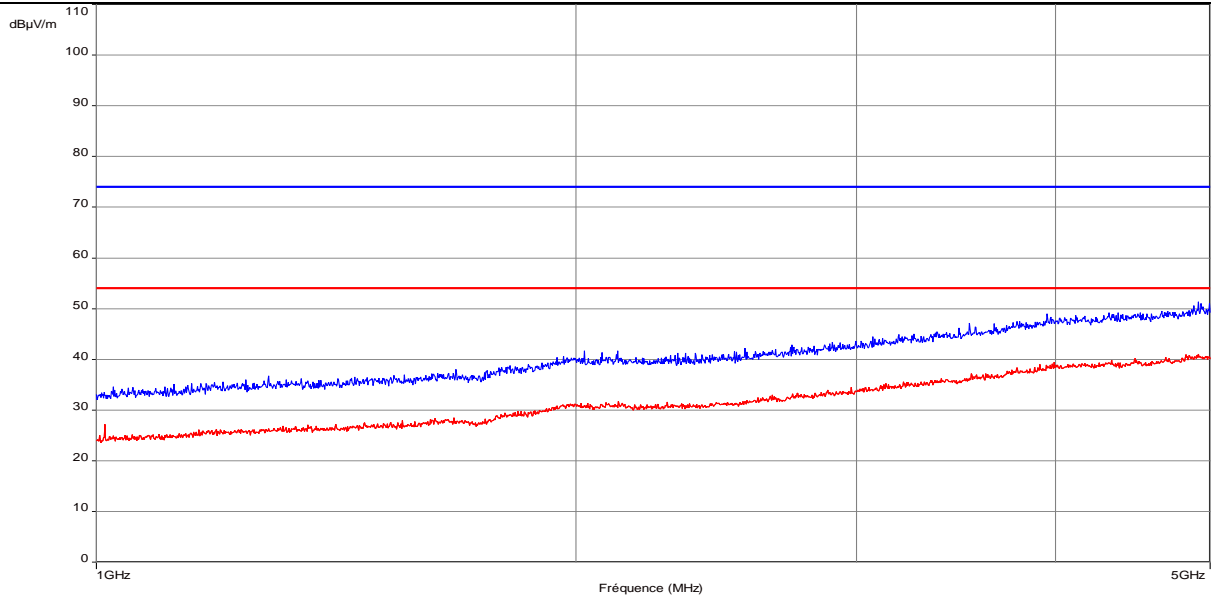

Vertical polarization

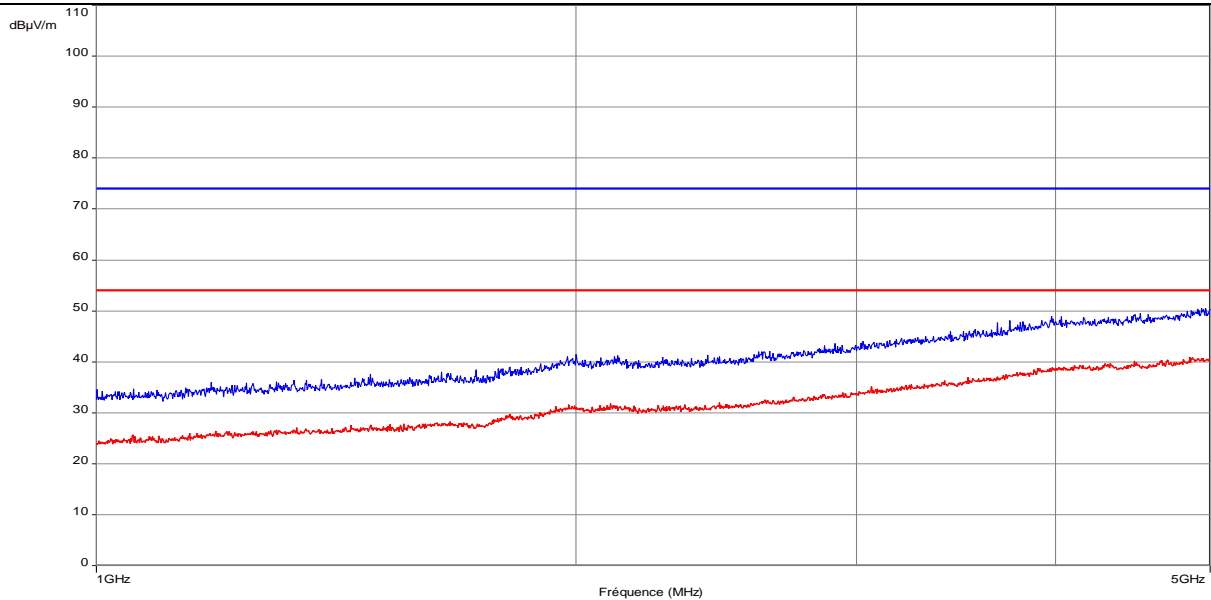

----- : Peak measure / limit

----- : Average measure / limit

Note: Pre-scan graph only for identification purpose.

Marker List :

Frequency (MHz)	Peak Level (dBµV/m)	Limit (dBµV/m)	Polarization
-	-	-	-

9. 6dB Bandwidth

TEST: 6dB Bandwidth			Verdict								
<p><u>Method:</u> The setup is in an anechoic chamber. The spectrum analyzer is connected to the measuring antenna. A radiated measurement is performed. The RBW is 100kHz, with VBW $\geq 3 \times$ RBW. The SPAN is wide enough to capture all products of the modulation process. A MaxHold Peak detector is used. The tested equipment is set to transmit operation with modulation on low, mid and high channels.</p>			Pass								
<p>Laboratory Parameters:</p> <table border="1" style="width: 100%; border-collapse: collapse;"> <thead> <tr> <th style="width: 33%;"></th> <th style="width: 33%;">Required prior to the test</th> <th style="width: 33%;">During the test</th> </tr> </thead> <tbody> <tr> <td>Ambient Temperature</td> <td style="text-align: center;">20 to 30 °C</td> <td style="text-align: center;">23°C \pm 2</td> </tr> <tr> <td>Relative Humidity</td> <td style="text-align: center;">25 to 70 %</td> <td style="text-align: center;">58% \pm 5</td> </tr> </tbody> </table>					Required prior to the test	During the test	Ambient Temperature	20 to 30 °C	23°C \pm 2	Relative Humidity	25 to 70 %
	Required prior to the test	During the test									
Ambient Temperature	20 to 30 °C	23°C \pm 2									
Relative Humidity	25 to 70 %	58% \pm 5									
Limits – FCC Part 15.247 (a) / RSS-247 §5.2 (a)											
Frequency (MHz)	Level for Bandwidth	Limit									
2402.0	6dB below the maximum output power	At least 500kHz									
2440.0											
2480.0											
<p>Supplementary information: Test location: SMEE. Test date: June 5th, 2018. Tested by L. CHAPUS</p>											

Test Equipment Used					
Description	Manufacturer	Model	Identifier	Cal. Date	Cal. Due
Horn antenna	ETS-LINDGREN	3115	ANT-141-013	2014/3	2019/3
RF cable	Pasternack RF	PE302-120	CAB-131-024	2018/4	2019/4
RF cable	HUBER+SUHNER	SF104	CAB-141-030	2018/4	2019/4
Anechoic chamber	COMTEST	214263	CAG-141-001	2017/6	2020/6
Turntable	Innco- Systems	CT0800	PLA-141-001	-	-
Measuring receiver	Rohde&Schwarz	ESRP	REC-151-003	2017/3	2019/3

Test Setup for radiated emission

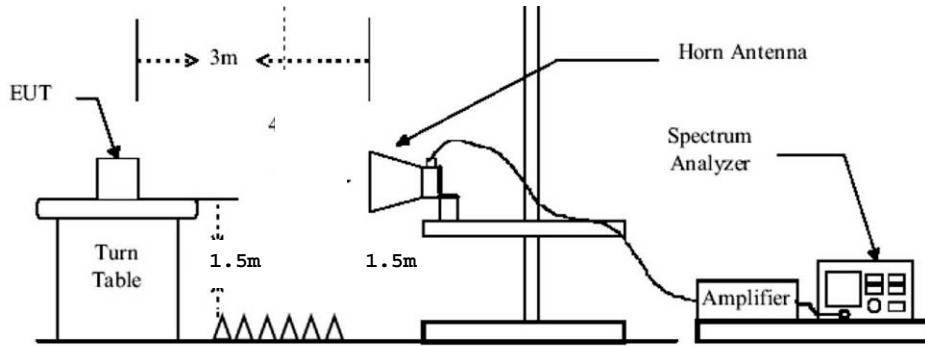

Test setup for 1-25GHz

Tabulated Results for Occupied Bandwidth

Frequency (MHz)	6dB Bandwidth (kHz)	Result
802.11b		
2412.0	10.166	Pass
2437.0	10.142	Pass
2462.0	10.930	Pass
802.11g		
2412.0	16.361	Pass
2437.0	16.464	Pass
2462.0	16.371	Pass
802.11n		
2412.0	17.559	Pass
2437.0	17.614	Pass
2462.0	17.608	Pass

Graphical representation of 6dB Bandwidth (WIFI 802.11b)

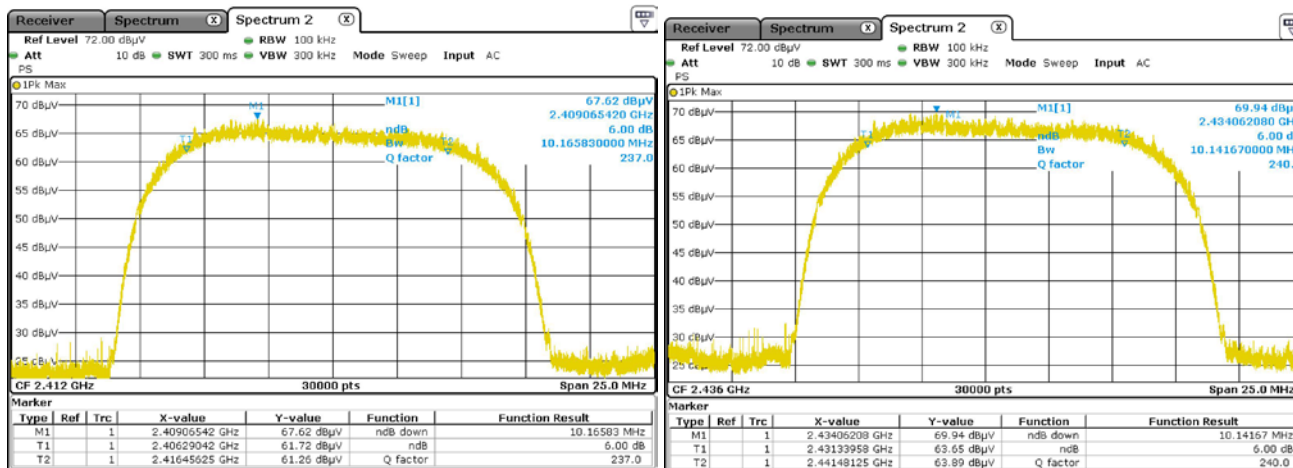

Low channel / Mid channel

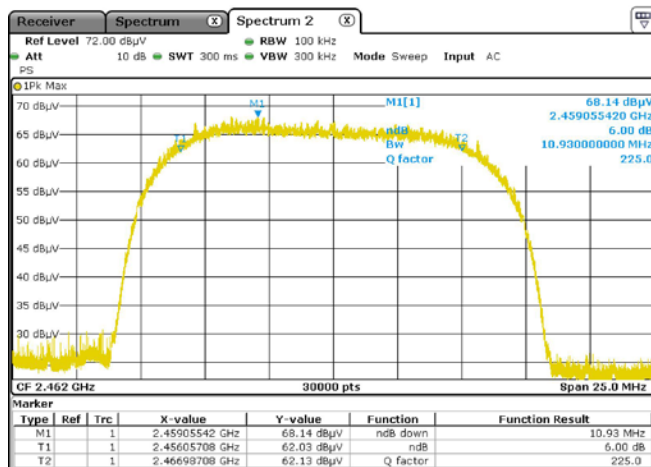

High channel

Frequency band investigated:	2400MHz to 2483.5MHz
RBW :	100kHz
Measurement detector :	Peak

Graphical representation of 6dB Bandwidth (WIFI 802.11g)

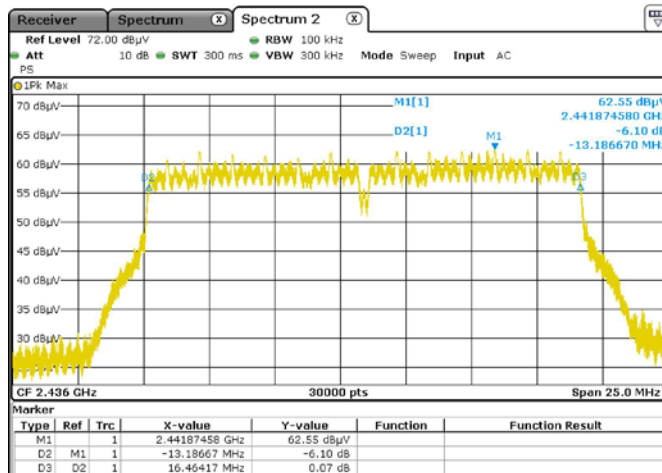
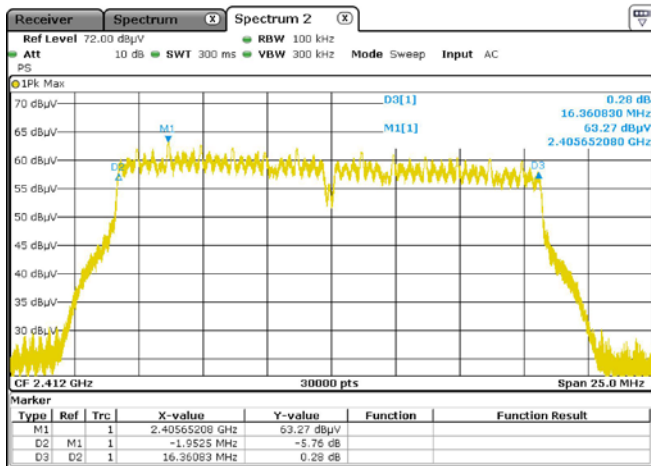

Low channel / Mid channel

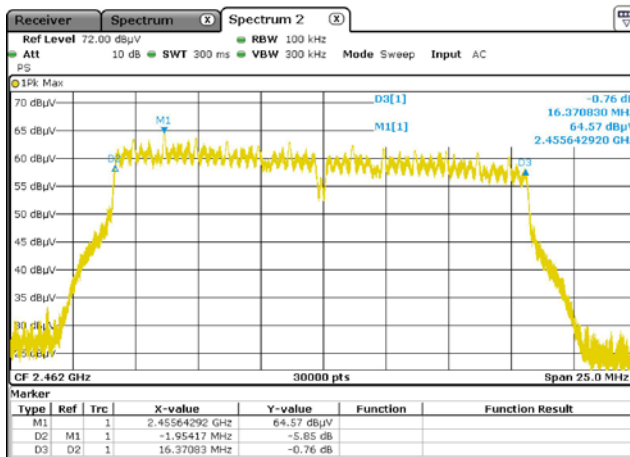

High channel

Frequency band investigated: 2400MHz to 2483.5MHz

RBW : 100kHz

Measurement detector : Peak

Graphical representation of 6dB Bandwidth (WIFI 802.11n)

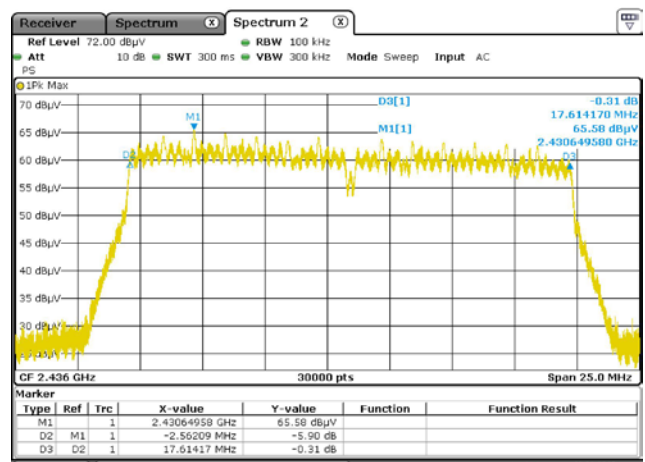
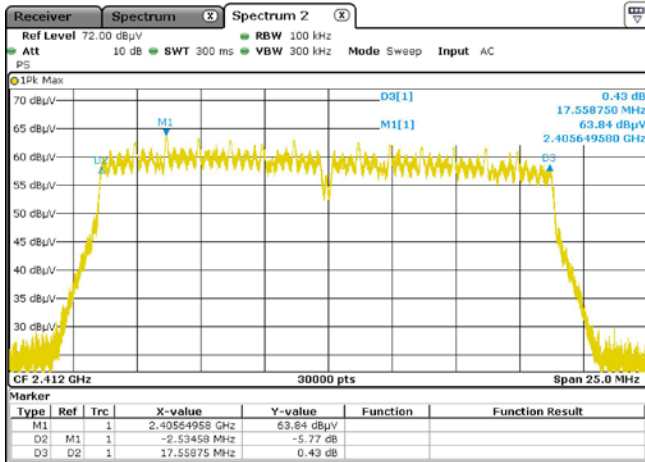

Low channel / Mid channel

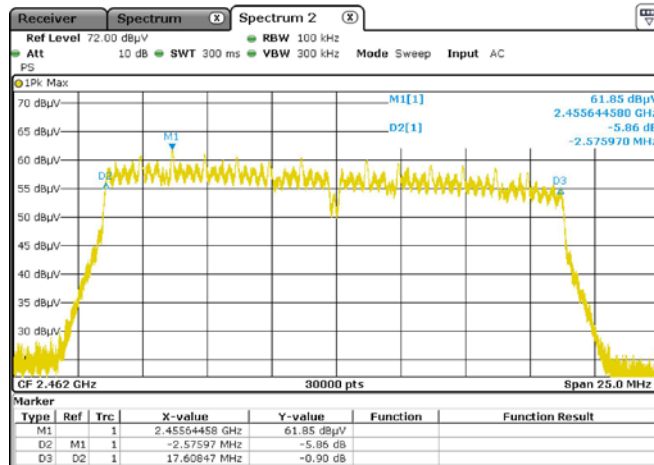

High channel

Frequency band investigated:	2400MHz to 2483.5MHz
RBW :	100kHz
Measurement detector :	Peak

10. Maximum Conducted (Average) Output power

TEST: Maximum Average conducted output power		Verdict
<p><u>Method:</u> A radiated measurement is performed with a spectrum analyzer. The RBW is set to 1 % to 5 % of the OBW, not to exceed 1 MHz. The SPAN is set to at least 1.5 x OBW. Radiated field strength of RF Output Power is measured at 3m in a Full Anechoic Chamber (FAC) that complies with ANSI C63.10. Maximum field strength is performed by rotating the EUT 360°. All frequencies were investigated in both horizontal and vertical antenna polarity. Three orthogonal axis measurements on EUT are performed to obtain the maximum peak field strength, with a 60° rotation on each axis. (Clause 6.6.5 of ANSI C63.10). The tested equipment is set to transmit operation with modulation on low, mid and high channels.</p>		Pass
Laboratory Parameters:	Required prior to the test	During the test
Ambient Temperature	20 to 30 °C	23°C ± 2
Relative Humidity	25 to 70 %	64% ± 5
Limits – FCC Part 15.247 (b) / RSS-247 §5.4 (d)		
Frequency (MHz)	Limits (dBµV/m)	
	Level / Detector	Results
2400 to 2483.5	36 dBm / Pk / 3m (Radiated)	Pass
2400 to 2483.5	30 dBm / Pk (Conducted)	Pass
Supplementary information:		
Test location: SMEE.		
Test date: June 6 th , 2018. Tested by L. CHAPUS		

Test Equipment Used					
Description	Manufacturer	Model	Identifier	Cal. Date	Cal. Due
Horn antenna	ETS-LINDGREN	3115	ANT-141-013	2014/3	2019/3
RF cable	Pasternack RF	PE302-120	CAB-131-024	2018/4	2019/4
RF cable	HUBER+SUHNER	SF104	CAB-141-030	2018/4	2019/4
Anechoic chamber	COMTEST	214263	CAG-141-001	2017/6	2020/6
Turntable	Innco- Systems	CT0800	PLA-141-001	-	-
Measuring receiver	Rohde&Schwarz	ESRP	REC-151-003	2017/3	2019/3

Test Setup for radiated emission

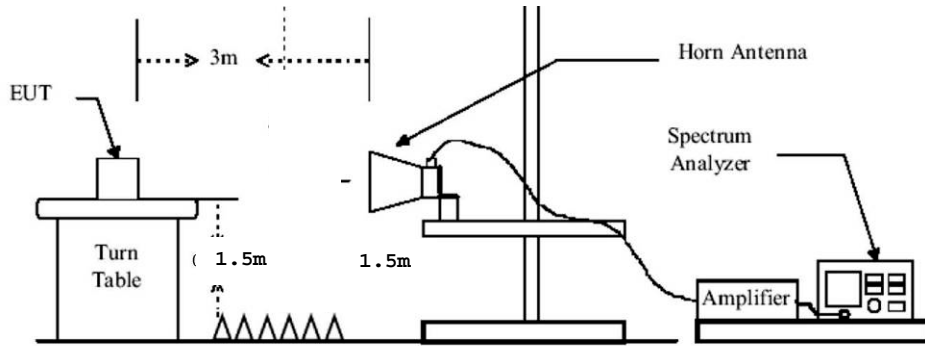

Test setup for 1-25GHz

Tabulated Results for Maximum average output power (Radiated measurement)				
FREQ	Field Strength 3m	Calculated EIRP	Limit	Result
(MHz)	(dBμV/m)	(dBm)	(dBm)	
802.11b (1Mbps)				
2412.0	105.5	10.2	35.6	Pass
2437.0	105.7	10.4	35.6	Pass
2462.0	105.7	10.4	35.6	Pass
802.11b (11Mbps)				
2412.0	109.4	14.1	35.6	Pass
2437.0	110.2	14.9	35.6	Pass
2462.0	111.1	15.8	35.6	Pass
802.11g (6Mbps)				
2412.0	107.0	11.7	35.6	Pass
2437.0	107.5	12.2	35.6	Pass
2462.0	108.1	12.8		
802.11g (54Mbps)				
2412.0	106.9	11.6	35.6	Pass
2437.0	107.1	11.8	35.6	Pass
2462.0	107.5	12.2	35.6	Pass
802.11n (7Mbps)				
2412.0	107.2	11.9	35.6	Pass
2437.0	107.9	12.6	35.6	Pass
2462.0	108.3	13.0	35.6	Pass
802.11n (72Mbps)				
2412.0	106.6	11.3	35.6	Pass
2437.0	106.9	11.6	35.6	Pass
2462.0	107.6	12.3	35.6	Pass
Measurement distance:		3m		
Limit:		FCC Part 15.247 / RSS-247		
Wide Measurement Uncertainty:		± 5.6dB (k=2)		
RESULT:		PASS		
Note:		<p>(1): The field strength (level) is calculated by adding the Antenna Factor and Cable Factor, and subtracting the Amplifier Gain (if any) from the measured reading. The basic equation is as follow: $FS = RA + AF + CF - AG$ Where FS = Field Strength RA = Receiver Amplitude AF = Antenna Factor CF = Cable Factor AG = Amplifier Gain Total factor (dB) is AF + CF – AG Margin value = Emission level – Limit value</p> <p>(2): EIRP is calculated using the following equation: $EIRP = E + 20 \times \log(D) - 104.8 - GR$ Where EIRP = Equivalent Isotropic Radiated Power in dBm E = Electric field strength in dBμV/m D = Measuring distance in meter GR = Ground reflection in dB (0dB above 1GHz)</p> <p>(3): Method used as per KDB 558074 D01 DTS Meas Guidance v04 : AVGSA-1</p> <p>(4): Limit is reduced by 0.4dB because of antenna gain 6.4dBi.</p>		

Tabulated Results for Maximum peak output power (Conducted)			
FREQ (MHz)	Conducted power (dBm)	Limit (dBm)	Result
802.11b (1Mbps)			
2412.0	3.8	29.6	2412.0
2437.0	4.0	29.6	2437.0
2462.0	4.0	29.6	2462.0
802.11b (11Mbps)			
2412.0	7.7	29.6	2412.0
2437.0	8.5	29.6	2437.0
2462.0	9.4	29.6	2462.0
802.11g (6Mbps)			
2412.0	5.3	29.6	2412.0
2437.0	5.8	29.6	2437.0
2462.0	6.4	29.6	2462.0
802.11g (54Mbps)			
2412.0	5.2	29.6	2412.0
2437.0	5.4	29.6	2437.0
2462.0	5.8	29.6	2462.0
802.11n (7Mbps)			
2412.0	5.5	29.6	2412.0
2437.0	6.2	29.6	2437.0
2462.0	6.6	29.6	2462.0
802.11n (72Mbps)			
2412.0	4.9	29.6	2412.0
2437.0	5.2	29.6	2437.0
2462.0	5.9	29.6	2462.0
Limit:	FCC Part 15.247 / IC RSS-247		
RESULT:	PASS		
Note:	(1): Maximum conducted Peak output power is calculated as follow: $P_c = EIRP - G$ Where P_c = Conducted power dBm $EIRP$ = Equivalent Isotropic Radiated Power in dBm G = Antenna gain in dBi (6.4dBi, as declared by the manufacturer) (2): Limit is reduced by 0.4dB because of antenna gain 6.4dBi.		

11. Maximum Power Spectral Density Level in the fundamental emission

TEST: Maximum Peak Power Spectral Density		Verdict					
<p><u>Method:</u> A radiated measurement is performed with a spectrum analyzer. The RBW is set to 3kHz. The SPAN is set to at least 1.5 x OBW. Radiated field strength of RF Output Power is measured at 3m in a Full Anechoic Chamber (FAC) that complies with ANSI C63.10. Maximum field strength is performed by rotating the EUT 360°. All frequencies were investigated in both horizontal and vertical antenna polarity. Three orthogonal axis measurements on EUT are performed to obtain the maximum peak field strength, with a 60° rotation on each axis. (Clause 6.6.5 of ANSI C63.10). The tested equipment is set to transmit operation with modulation on low, mid and high channels.</p>		Pass					
Laboratory Parameters:	<table border="1"> <thead> <tr> <th>Required prior to the test</th> <th>During the test</th> </tr> </thead> <tbody> <tr> <td>Ambient Temperature</td> <td>20 to 30 °C</td> </tr> <tr> <td>Relative Humidity</td> <td>25 to 70 %</td> </tr> </tbody> </table>		Required prior to the test	During the test	Ambient Temperature	20 to 30 °C	Relative Humidity
Required prior to the test	During the test						
Ambient Temperature	20 to 30 °C						
Relative Humidity	25 to 70 %						
Limits – FCC Part 15.247 (e) / RSS-247 §5.2 (b)							
Frequency (MHz)	Level	Limit					
2412-2462	8 dBm/3kHz	Pass					
Supplementary information: Test location: SMEE. Test date: June 5 th , 2018. Tested by L. CHAPUS							

Test Equipment Used					
Description	Manufacturer	Model	Identifier	Cal. Date	Cal. Due
Horn antenna	ETS-LINDGREN	3115	ANT-141-013	2014/3	2019/3
RF cable	Pasternack RF	PE302-120	CAB-131-024	2018/4	2019/4
RF cable	HUBER+SUHNER	SF104	CAB-141-030	2018/4	2019/4
Anechoic chamber	COMTEST	214263	CAG-141-001	2017/6	2020/6
Turntable	Innco- Systems	CT0800	PLA-141-001	-	-
Measuring receiver	Rohde&Schwarz	ESRP	REC-151-003	2017/3	2019/3

Test Setup for radiated emission

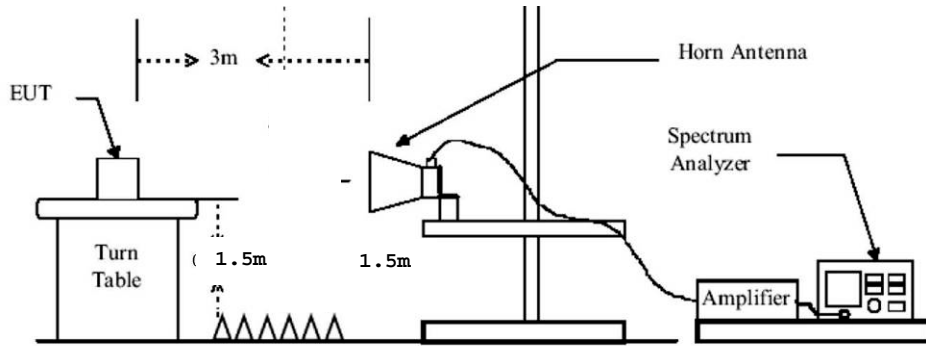

Test setup for 1-25GHz

Tabulated Results for Maximum Spectral Density (Radiated measurement)				
FREQ	Field Strength 3m	Calculated Radiated PSD (EIRP)	Limit	Result
(MHz)	(dBµV/m)	(dBm)	(dBm)	
802.11b (11Mbps)				
2412.0	81.0	-14.3	-	-
2437.0	81.1	-14.2	-	-
2462.0	80.2	-15.1	-	-
802.11g (6Mbps)				
2412.0	81.1	-14.2	-	-
2437.0	81.6	-13.7	-	-
2462.0	79.8	-15.5	-	-
802.11n (7Mbps)				
2412.0	80.2	-15.1	-	-
2437.0	81.9	-13.4	-	-
2462.0	80.1	-15.2	-	-
RBW:	3kHz			
Measurement distance:	3m			
Limit:	FCC Part 15.247 / RSS-247			
Final measurement detector:	Peak			
Wide Measurement Uncertainty:	± 5.6dB (k=2)			
Note:	<p>(1): The field strength (level) is calculated by adding the Antenna Factor and Cable Factor, and subtracting the Amplifier Gain (if any) from the measured reading. The basic equation is as follow: $FS = RA + AF + CF - AG$ Where FS = Field Strength RA = Receiver Amplitude AF = Antenna Factor CF = Cable Factor AG = Amplifier Gain Total factor (dB) is AF + CF - AG Margin value = Emission level - Limit value</p> <p>(2): EIRP/PSD is calculated using the following equation: $EIRP = E + 20 \times \log(D) - 104.8 - GR$ Where EIRP = Equivalent Isotropic Radiated Power in dBm E = Electric field strength in dBµV/m D = Measuring distance in meter GR = Ground reflection in dB (0dB above 1GHz)</p> <p>(3): Method used as per KDB 558074 D01 DTS Meas Guidance v04 : AVGPSD-1</p>			

Tabulated Results for Maximum Conducted Power Spectral Density			
Frequency (MHz)	PSD (dBm/3kHz)	Limit	Result
802.11b (11Mbps)			
2412	-20.7	8dBm/3kHz	Pass
2437	-20.6	8dBm/3kHz	Pass
2462	-21.5	8dBm/3kHz	Pass
802.11g (6Mbps)			
2412	-20.6	8dBm/3kHz	Pass
2437	-20.1	8dBm/3kHz	Pass
2462	-21.9	8dBm/3kHz	Pass
802.11n (7Mbps)			
2412	-21.5	8dBm/3kHz	Pass
2437	-19.8	8dBm/3kHz	Pass
2462	-21.6	8dBm/3kHz	Pass
RBW:	3kHz		
Limit:	FCC Part 15.247 / RSS-247		
Final measurement detector:	RMS (Method)		
RESULT:	PASS		
Note:	(1): Maximum conducted power spectral density is calculated as follow: $P_{SD} = EIRP - G$ Where P_{SD} = Conducted power spectral density EIRP = Equivalent Isotropic Radiated Power in dBm G = Antenna gain in dBi (6.4dBi, as declared by the manufacturer)		

Graphical representation for Maximum Power Spectral Density / 802.11b

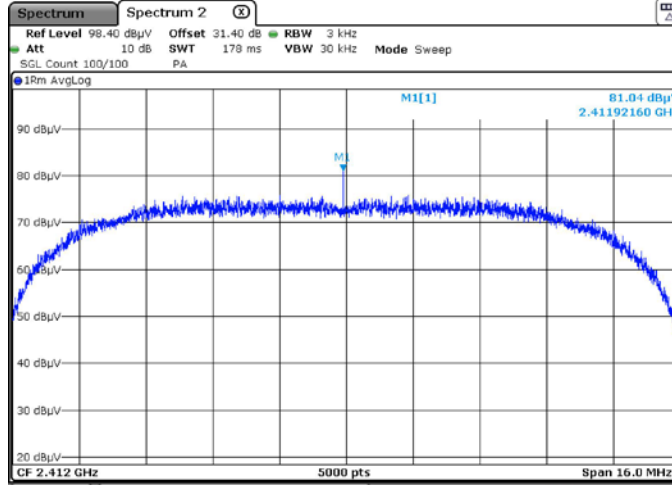

Low channel

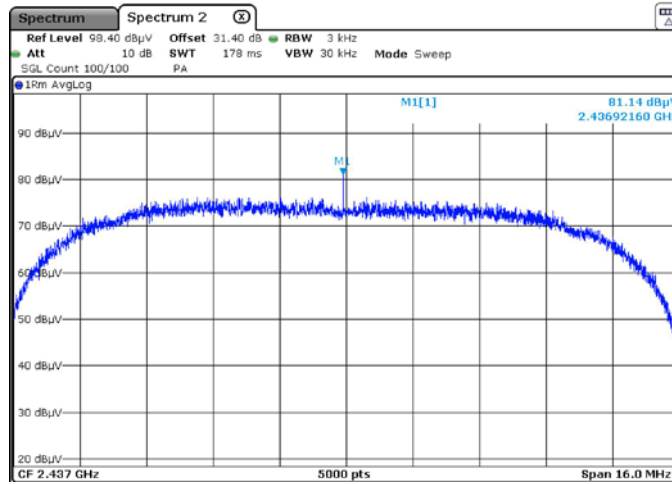

Mid channel

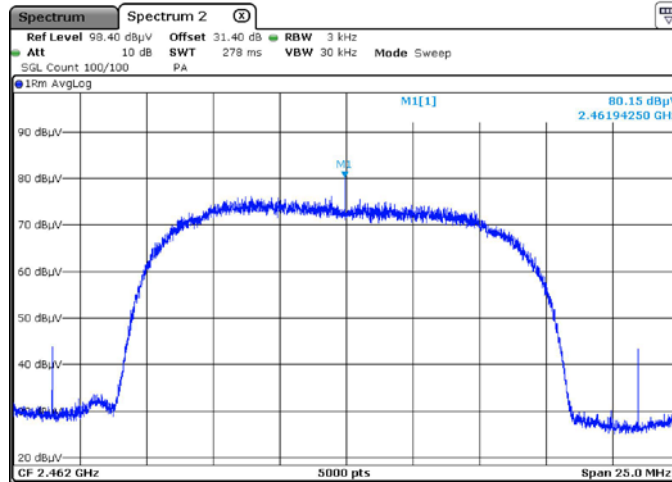

High channel

Graphical representation for Maximum Power Spectral Density / 802.11g

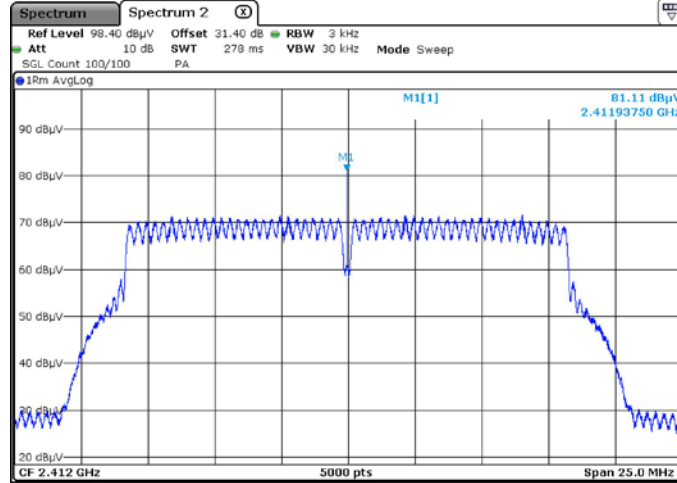

Low channel

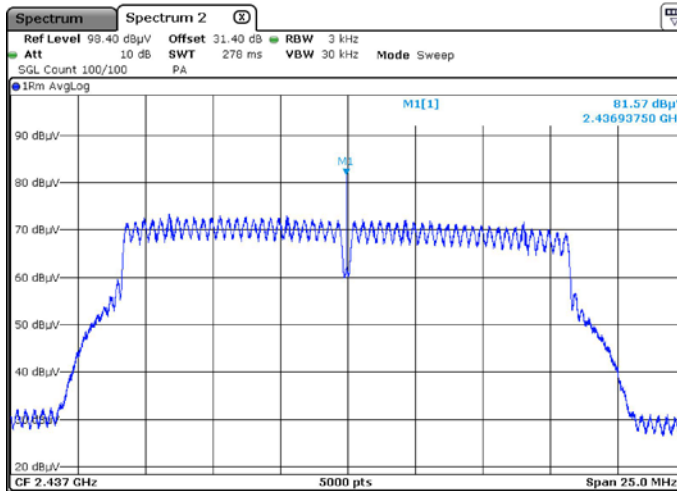

Mid channel

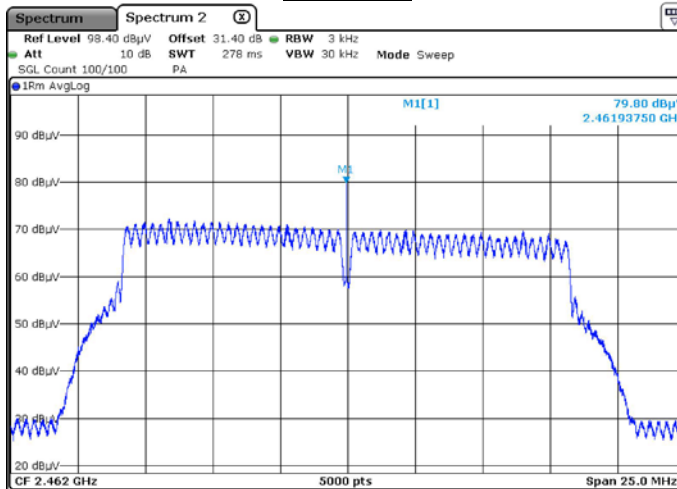

High channel

Graphical representation for Maximum Power Spectral Density / 802.11n

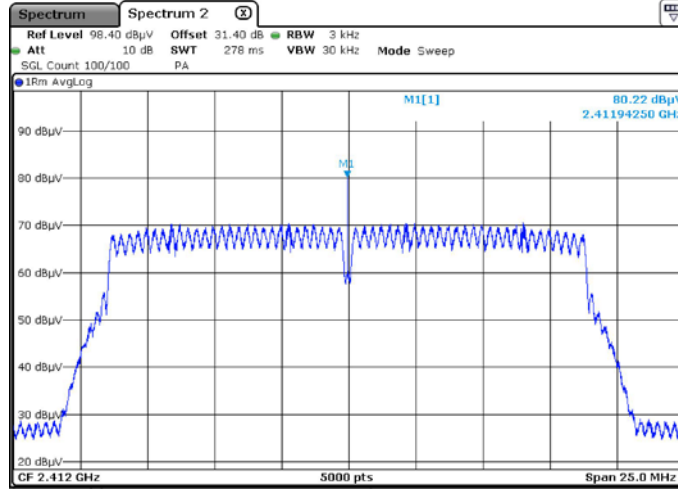

Low channel

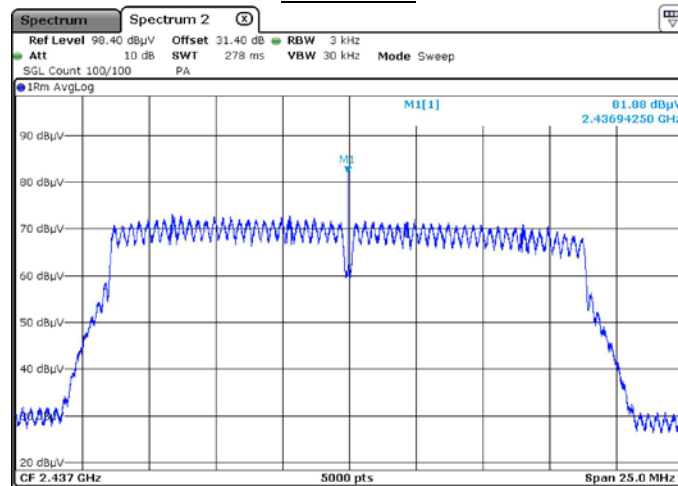

Mid channel

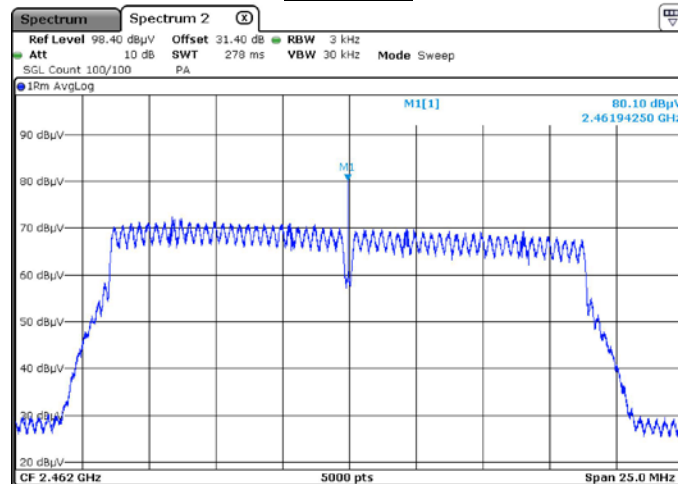

High channel

12. Unwanted emissions in Non-Restricted Frequency bands

TEST: Unwanted emissions in Non-Restricted Frequency Bands			Verdict
<p>Method: Measurements were performed on a 3-meter Open Area Test Site (OATS) for frequency below 1GHz. The EUT was rotated 360° about its azimuth with the receive antenna located at various heights in horizontal and vertical polarities. Final measurements (Peak) were then performed by rotating the EUT on 360° and adjusting the receive antenna height from 1 to 4 m For frequency above 1GHz, final measurements were made at 3m in a Full Anechoic Chamber (FAC) that complies with ANSI C63.10. Measurements were performed at an antenna to EUT separation distance of 3 meter. The EUT was rotated 360° about its azimuth with the receive antenna in horizontal and vertical polarities. Three orthogonal axis measurements on EUT are performed to obtain the maximum peak field strength, with 60° rotation on each axis. (Clause 6.6.5 of ANSI C63.10). A pre-scan frequency identification of the EUT has been performed in full anechoic chamber. The measured radiated field of the EUT is performed (or corrected) at 3-meters of distance. Antenna is 1.25-meters high. The pre-characterization graphs are obtained in PEAK detection with 360° continuous rotation of the device under test.</p>			Pass
Laboratory Parameters:	Required prior to the test	During the test	
Ambient Temperature	20 to 30 °C	23°C ± 2	
Relative Humidity	25 to 70 %	64% ± 5	
Fully configured sample scanned over the following frequency range	Frequency range on each side of line	Measurement Point	
	30MHz – 25GHz	3 m measurement distance	
Limits – FCC Part 15.247 (d) / RSS-247 § 5.5			
Frequency (MHz)	Limits (dBµV/m)		
	Detector / Analyser RBW	Limit	Results
30 to 25000	Pk / 100kHz	30dB below the maximum Peak level	Pass
Supplementary information:			
Test location: SMEE.			
Test date: June 6 th and 7 th , 2018. Tested by L. CHAPUS			

Test Equipment Used					
Description	Manufacturer	Model	Identifier	Cal. Date	Cal. Due
Log-periodic antenna	TDK	PLP3003	ANT-101-001	2017/5	2019/5
Biconnic antenna	COM-POWER	AB- 900	ANT-101-003	2017/5	2019/5
Loop antenna	EMCO	6502	ANT-101-009	2017/8	2019/8
BiConiLog antenna	EMCO	3142B	ANT-101-010	2017/7	2019/7
Horn antenna	ETS-LINDGREN	3115	ANT-141-013	2014/3	2019/3
Horn antenna	ETS-LINDGREN	3116	ANT-161-014	2017/12	2022/12
Spectrum analyzer	Rohde&Schwarz	FSV40	ASP-171-004	2017/5	2019/5
RF cable	Div	OATS/25m	CAB-101-017	2018/4	2019/4
RF cable	Pasternack RF	PE302-120	CAB-131-024	2018/4	2019/4
RF cable	HUBER+SUHNER	RG214U	CAB-141-026	2018/4	2019/4

Test Equipment Used					
Description	Manufacturer	Model	Identifier	Cal. Date	Cal. Due
RF cable	HUBER+SUHNER	RG214U	CAB-141-029	2018/4	2019/4
RF cable	HUBER+SUHNER	SF104	CAB-141-030	2018/4	2019/4
RF cable	HUBER+SUHNER	SF102 (K/2m)	CAB-171-034	2017/5	2019/5
RF cable	HUBER+SUHNER	SF102 (K/3m)	CAB-171-034	2017/5	2019/5
Anechoic chamber	COMTEST	214263	CAG-141-001	2017/6	2020/6
Antenna mast	Innco- Systems	MA4000EP	MAT-101-001	-	-
Turntable	Innco- Systems	DS1200S	PLA-101-001	-	-
Turntable	Innco- Systems	CT0800	PLA-141-001		
Pre-amplifier	PE	1524	PRE-101-002	2017/6	2018/6
Pre-amplifier	SMEE	18-40GHz	PRE-171-004	2017/12	2018/12
Measuring receiver	Rohde&Schwarz	ESRP	REC-151-003	2017/3	2019/3
OATS	Div	10m	SIT-101-001	2017/7	2020/7
EMC Software	NEXIO	BAT EMC V3.8	SOF-101-001	-	-

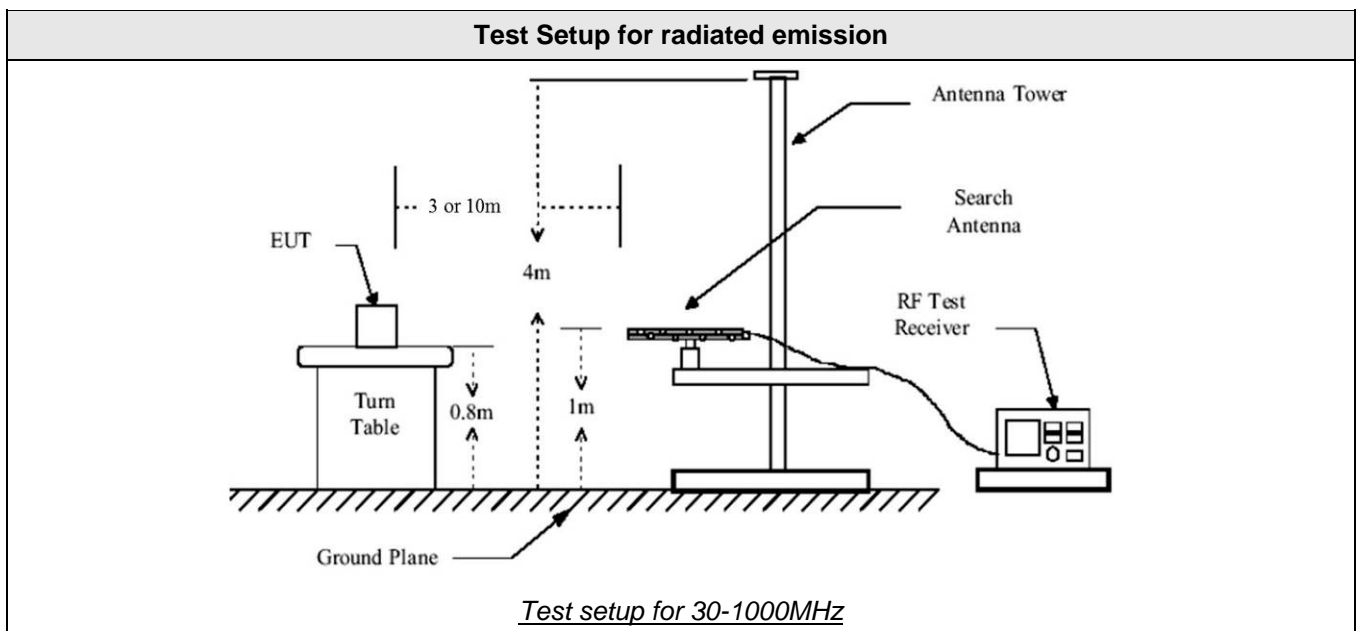

Test Setup for radiated emission

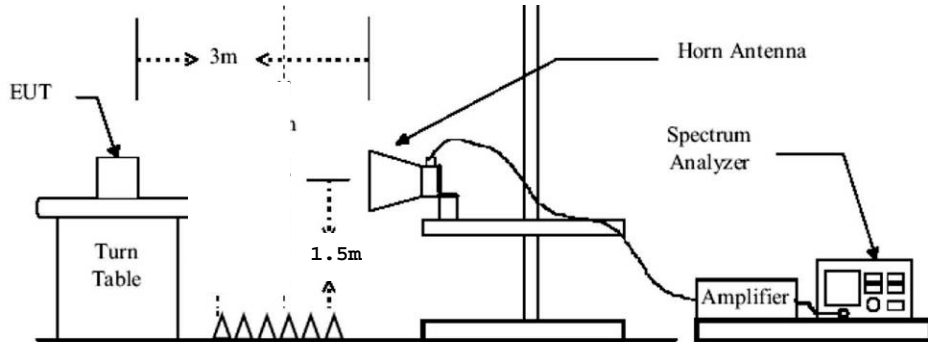

Test setup for 1-25GHz

Tabulated Results for Peak Output Power Reference level

802.11b	
FREQ (MHz)	Field Strength 3m (dB μ V/m)
2402.0	100.9
2440.0	102.2
2480.0	101.0
802.11g	
FREQ (MHz)	Field Strength 3m (dB μ V/m)
2402.0	96.4
2440.0	97.6
2480.0	96.6
802.11n	
FREQ (MHz)	Field Strength 3m (dB μ V/m)
2402.0	96.2
2440.0	98.3
2480.0	96.8
RBW:	100kHz
Measurement distance:	3m
Limit:	Ref. level only – For 15.247 (d) / RSS-247 § 5.5
Final measurement detector:	Peak
Wide Measurement Uncertainty:	± 5.6 dB (k=2)
Note:	(1): Only for identification of limit in non-restricted band Peak limit for out-of-band frequencies in Non-Restricted bands (with a 100kHz RBW on the spectrum analyser)

Tabulated Results for Unwanted emissions in Non-Restricted bands				
FREQ (MHz)	Field Strength 3m (dBµV/m)	Limit (dBµV/m)	Margin (dBµV/m)	Result (dBµV/m)
802.11b				
2399.942	62.0	72.2	-10.2	Pass
802.11g				
2399.942	60.8	67.6	-6.8	Pass
802.11n				
2399.942	62.2	68.3	-6.1	Pass
RBW:	100kHz			
Measurement distance:	3m			
Limit:	15.247 / RSS-247			
Final measurement detector:	Peak			
Wide Measurement Uncertainty:	± 5.6dB (k=2)			
RESULT:	PASS			
Note:	<p>(1): The field strength (level) is calculated by adding the Antenna Factor and Cable Factor, and subtracting the Amplifier Gain (if any) from the measured reading. The basic equation is as follow: $FS = RA + AF + CF - AG$ Where FS = Field Strength RA = Receiver Amplitude AF = Antenna Factor CF = Cable Factor AG = Amplifier Gain Total factor (dB) is $AF + CF - AG$ Margin value = Emission level – Limit value</p> <p>(2): Peak pre-scans not performed at 3-meters distance are corrected as follow: $M@3m = M@D_m + 20 \times \log(D_m / 3m)$ Where D is the measurement distance in meter</p> <p>(3): All frequencies not specified have margin < -10dB (4): Worst case between charge mode and normal used mode (5): 3-axis measurement performed for device under test.</p>			

Graphical representation of Band-edge compliance (LOW)

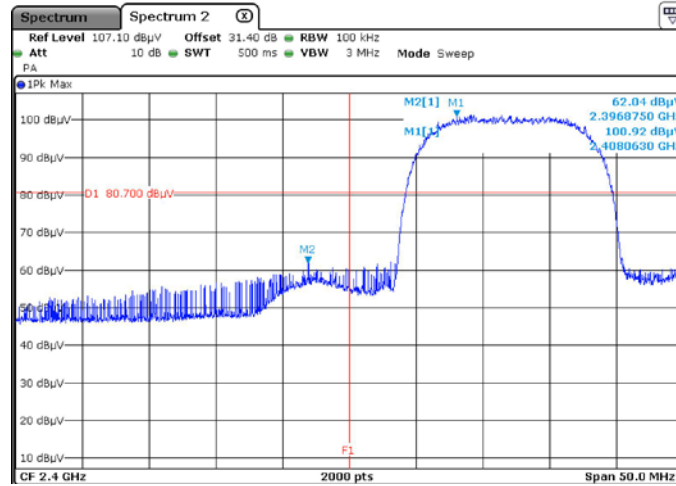

802.11b

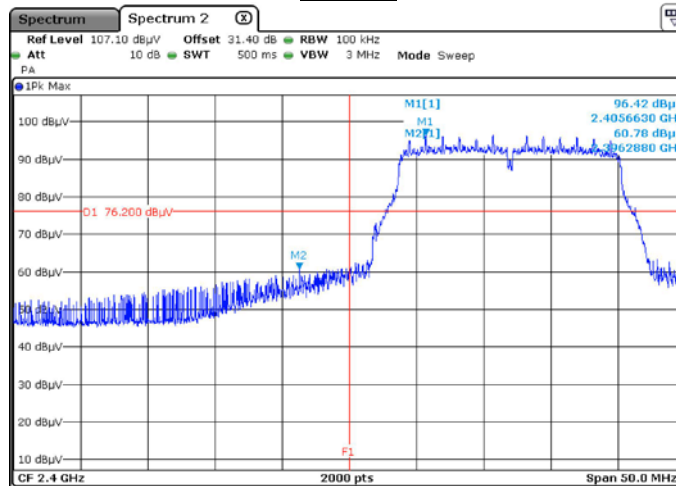

802.11g

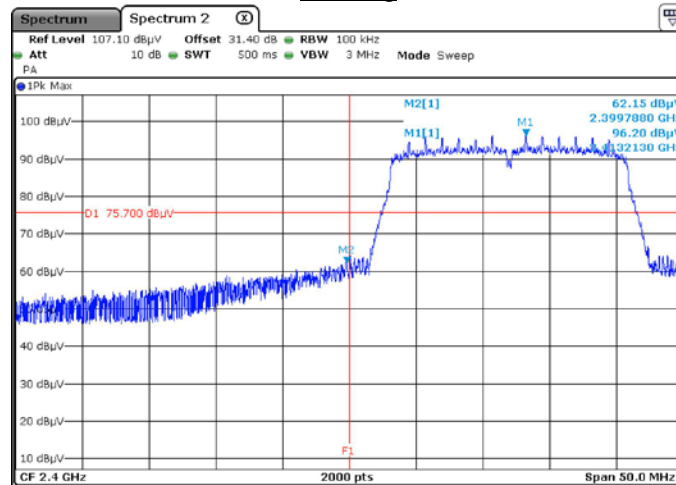

802.11n

F1 = 2400MHz

RESULT: PASS

Note: radiated measurement (3m in FAC)

13. Unwanted emissions in Restricted Frequency bands

TEST: Unwanted emissions into Restricted Frequency Bands		Verdict
<p>Method: Measurements were performed on a 3-meter Open Area Test Site (OATS) for frequency below 1GHz. The EUT was rotated 360° about its azimuth with the receive antenna located at various heights in horizontal and vertical polarities. Final measurements (Peak) were then performed by rotating the EUT on 360° and adjusting the receive antenna height from 1 to 4 m</p> <p>For frequency above 1GHz, final measurements were made at 3m in a Full Anechoic Chamber (FAC) that complies with ANSI C63.10. Measurements were performed at an antenna to EUT separation distance of 3 meter. The EUT was rotated 360° about its azimuth with the receive antenna in horizontal and vertical polarities.</p> <p>Three orthogonal axis measurements on EUT are performed to obtain the maximum peak field strength, with 60° rotation on each axis.(Clause 6.6.5 of ANSI C63.10).</p> <p>A pre-scan frequency identification of the EUT has been performed in full anechoic chamber. The measured radiated field of the EUT is performed (or corrected) at 3-meters of distance. Antenna is 1.25-meters high. The pre-characterization graphs are obtained in PEAK detection with 360° continuous rotation of the device under test.</p>		Pass
Laboratory Parameters:	Required prior to the test	During the test
Ambient Temperature	20 to 30 °C	23°C ± 2
Relative Humidity	25 to 70 %	64% ± 5
Fully configured sample scanned over the following frequency range	Frequency range on each side of line	Measurement Point
	9kHz – 30MHz	10 m measurement distance
	30MHz – 25GHz	3 m measurement distance
Limits – FCC Part 15.205, 15.209 (a), 15.247 (d) / RSS-GEN §8.9, §8.10, RSS-247 §5.5		
Frequency (MHz)	Limits (dBµV/m)	
	Level / Detector / Distance	Results
0.009 to 0.090	107.6 – 87.6 / AV / 10m 127.6 – 107.6 / PK / 10m	Pass
0.090 to 0.110	87.6 – 85.9 / QP / 10m	Pass
0.110 to 0.490	85.7 – 72.9 / AV / 10m 105.7 – 92.9 / PK / 10m	Pass
0.490 to 1.705	52.9 – 42.1 / QP / 10m	Pass
1.705 to 30	48.6 / QP / 10m	Pass
30 to 88	40.0 / QP / 3m	Pass
88 to 216	43.5 / QP / 3m	Pass
216 to 960	46.0 / QP / 3m	Pass
960-1000	54.0 / QP / 3m	Pass
Above 1GHz	54.0 / AV / 3m 74.0 / PK / 3m	Pass
Supplementary information: Test location: SMEE. Test date: June 6 th and 7 th , 2018. Tested by L. CHAPUS		

Test Equipment Used					
Description	Manufacturer	Model	Identifier	Cal. Date	Cal. Due
Log-periodic antenna	TDK	PLP3003	ANT-101-001	2017/5	2019/5
Biconnic antenna	COM-POWER	AB- 900	ANT-101-003	2017/5	2019/5
Loop antenna	EMCO	6502	ANT-101-009	2017/8	2019/8
BiConiLog antenna	EMCO	3142B	ANT-101-010	2017/7	2019/7
Horn antenna	ETS-LINDGREN	3115	ANT-141-013	2014/3	2019/3
Horn antenna	ETS-LINDGREN	3116	ANT-161-014	2017/12	2022/12
Spectrum analyzer	Rohde&Schwarz	FSV40	ASP-171-004	2017/5	2019/5
RF cable	Div	OATS/25m	CAB-101-017	2018/4	2019/4
RF cable	Pasternack RF	PE302-120	CAB-131-024	2018/4	2019/4
RF cable	HUBER+SUHNER	RG214U	CAB-141-026	2018/4	2019/4
RF cable	HUBER+SUHNER	RG214U	CAB-141-029	2018/4	2019/4
RF cable	HUBER+SUHNER	SF104	CAB-141-030	2018/4	2019/4
RF cable	HUBER+SUHNER	SF102 (K/2m)	CAB-171-034	2017/5	2019/5
RF cable	HUBER+SUHNER	SF102 (K/3m)	CAB-171-034	2017/5	2019/5
Anechoic chamber	COMTEST	214263	CAG-141-001	2017/6	2020/6
Antenna mast	Innco- Systems	MA4000EP	MAT-101-001	-	-
Turntable	Innco- Systems	DS1200S	PLA-101-001	-	-
Turntable	Innco- Systems	CT0800	PLA-141-001		
Pre-amplifier	PE	1524	PRE-101-002	2017/6	2018/6
Pre-amplifier	SMEE	18-40GHz	PRE-171-004	2017/12	2018/12
Measuring receiver	Rohde&Schwarz	ESRP	REC-151-003	2017/3	2019/3
OATS	Div	10m	SIT-101-001	2017/7	2020/7
EMC Software	NEXIO	BAT EMC V3.8	SOF-101-001	-	-

Test Setup for radiated emission

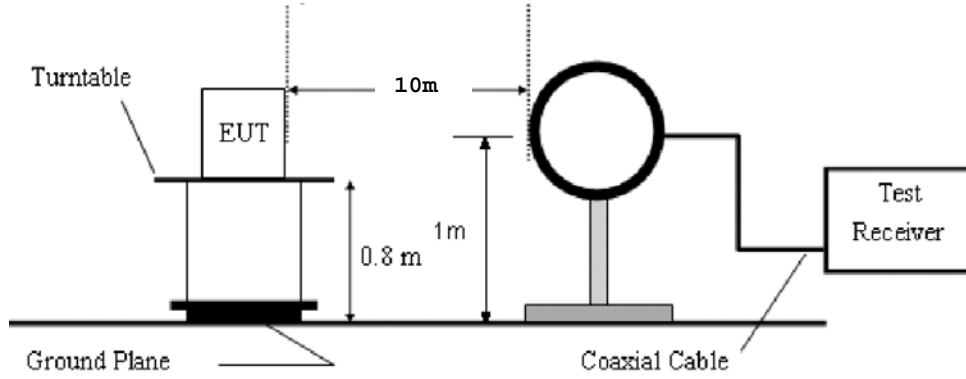

Test setup for 9k-30MHz

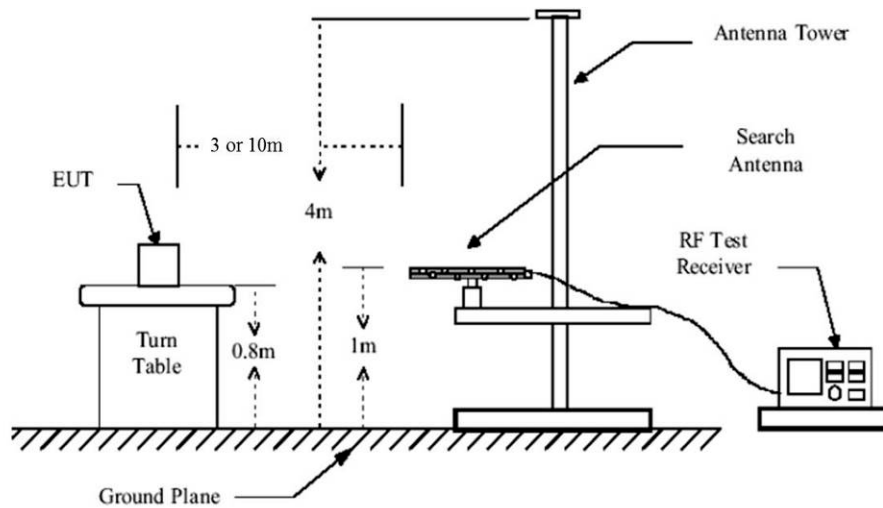

Test setup for 30-1000MHz

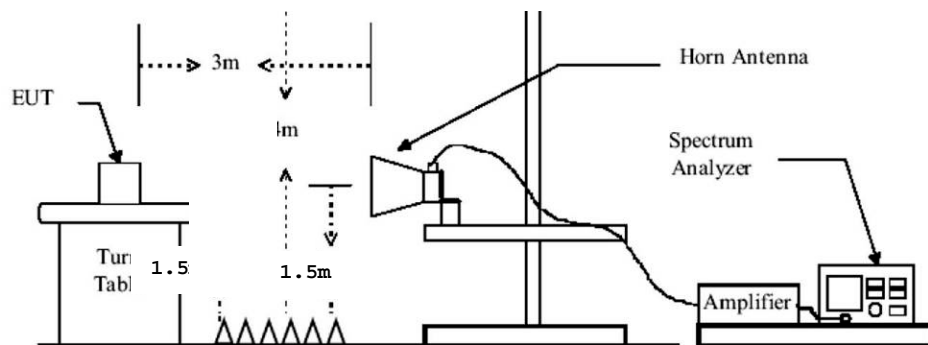

Test setup for 1-25GHz

Tabulated Results for Unwanted emissions (9kHz-30MHz)						
FREQ	RF field @ 30m	Limit @ 30m	Margin	Antenna angle	Table angle	Correc. Fact. (CF)
MHz	(QP) dB μ V/m	(QP) dB μ V/m	dB	Degree	Degree	dB
Margin < -10dB						
Supplementary information: Frequency list measured on the Open Area Test Site has been created with pre-scan results.						
Frequency band investigated:				9kHz-30MHz		
RBW:				200Hz (9kHz-150kHz) 9kHz (150kHz-30MHz)		
Measurement distance:				10m		
Limit:				FCC Part 15.205 - 15.209 / RSS-GEN		
Final measurement detector:				Peak / Quasi-Peak / Average		
Wide Measurement Uncertainty:				± 3.5 dB (k=2)		
Note:				CF: Correction factor = Antenna factor + Cable loss *1: Measure have been done at 10m distance and corrected according to requirements of 15.209.e) (M@30m = M@10m-19.1dB)		

Tabulated Results for Unwanted emissions (30MHz-1GHz)										
FREQ	Meter reading	Meter reading	Total factor	Field level	Field level	Pol	Antenna height	Table angle	Limit	Margin
MHz	(QP) dB μ V	(Pk) dB μ V	dB	(QP) dB μ V/m	(Pk) dB μ V/m		cm	Degré	(QP) dB μ V/m	dB
63.586	19.8	25.6	9.9	29.7	35.5	V	100	170	40.0	-10.3
179.987	14.1	16.8	17.9	32.0	34.7	V	125	160	43.5	-11.5
419.960	20.9	23.8	20.2	41.1	44.0	V	155	45	46.0	-4.9
Supplementary information: Frequency list measured on the Open Area Test Site has been created with pre-scan results.										
Frequency band investigated:				30MHz-1GHz						
RBW:				120kHz						
Measurement distance:				3m						
Limit:				FCC Part 15.205 - 15.209 / RSS-GEN						
Final measurement detector:				Quasi-Peak						
Wide Measurement Uncertainty:				± 5.6 dB (k=2)						
RESULT:				PASS						
Field Strength Calculation:				(1): The field strength (level) is calculated by adding the Antenna Factor and Cable Factor, and subtracting the Amplifier Gain (if any) from the measured reading. The basic equation is as follow: $FS = RA + AF + CF - AG$ Where FS = Field Strength RA = Receiver Amplitude AF = Antenna Factor CF = Cable Factor AG = Amplifier Gain Total factor (dB) is AF + CF - AG Margin value = Emission level - Limit value (2): Same results for all running mode (Low, mid, high channels) (3): Worst case results reported for battery charging mode.						

Tabulated Results for Unwanted emissions (1GHz-25GHz)					
FREQ (MHz)	Field Strength 3m (dBμV/m)	Detector	Limit (dBμV/m)	Margin (dBμV/m)	Result
802.11b					
2483.5	72.8	Pk	74	-1.2	Pass
2483.5	45.4	Avg	54	-8.6	Pass
4824.0	61.8	Pk	74	-12.2	Pass
4824.0	50.4	Avg	54	-3.6	Pass
4874.0	62.3	Pk	74	-11.7	Pass
4874.0	52.2	Avg	54	-1.8	Pass
4924.0	62.1	Pk	74	-11.9	Pass
4924.0	52.1	Avg	54	-1.9	Pass
7311.0	56.5	Pk	74	-17.5	Pass
7311.0	47.8	Avg	54	-6.2	Pass
7386.0	56.4	Pk	74	-17.6	Pass
7386.0	47.7	Avg	54	-6.3	Pass
802.11g					
2483.5	72.8	Pk	74	-1.2	Pass
2483.5	46.9	Avg	54	-7.1	Pass
4824.0	56.8	Pk	74	-17.2	Pass
4824.0	48.2	Avg	54	-5.8	Pass
4874.0	57.1	Pk	74	-16.9	Pass
4874.0	48.9	Avg	54	-5.1	Pass
4924.0	56.9	Pk	74	-17.1	Pass
4924.0	48.2	Avg	54	-5.8	Pass
7311.0	54.5	Pk	74	-19.5	Pass
7311.0	45.8	Avg	54	-8.2	Pass
7386.0	54.8	Pk	74	-19.2	Pass
7386.0	46.1	Avg	54	-7.9	Pass
802.11n					
2483.5	72.8	Pk	74	-1.2	Pass
2483.5	47.8	Avg	54	-6.2	Pass
4824.0	57.1	Pk	74	-16.9	Pass
4824.0	48.5	Avg	54	-5.5	Pass
4874.0	57.5	Pk	74	-16.5	Pass
4874.0	49.2	Avg	54	-4.8	Pass
4924.0	56.8	Pk	74	-17.2	Pass
4924.0	48.1	Avg	54	-5.9	Pass
7311.0	54.1	Pk	74	-19.9	Pass
7311.0	45.5	Avg	54	-8.5	Pass
7386.0	54.4	Pk	74	-19.6	Pass
7386.0	46.2	Avg	54	-7.8	Pass
RBW / VBW	1MHz / 3MHz				
Measurement distance:	3m				
Limit:	FCC Part 15.205, 15.209, 15.247 / RSS-Gen, RSS-247				
Final measurement detector:	Peak / Average				
Wide Measurement Uncertainty:	± 5.6dB (k=2)				
RESULT:	PASS				

Notes:

(1): The field strength (level) is calculated by adding the Antenna Factor and Cable Factor, and subtracting the Amplifier Gain (if any) from the measured reading. The basic equation is as follow:

$$FS = RA + AF + CF - AG$$

Where FS = Field Strength

RA = Receiver Amplitude

AF = Antenna Factor

CF = Cable Factor

AG = Amplifier Gain

Total factor (dB) is $AF + CF - AG$

Margin value = Emission level – Limit value

(2): Peak pre-scans not performed at 3-meters distance are corrected as follow:

$$M@3m = M@Dm + 20 \times \log (Dm / 3m)$$

Where D is the measurement distance in meter

(3): All frequencies not specified have margin < -10dB (for peak and average detector)

(4): Worst case between charge mode and normal used mode

(5): 3-axis measurement performed for device under test.

Graphical representation of Band-edge compliance (HIGH)

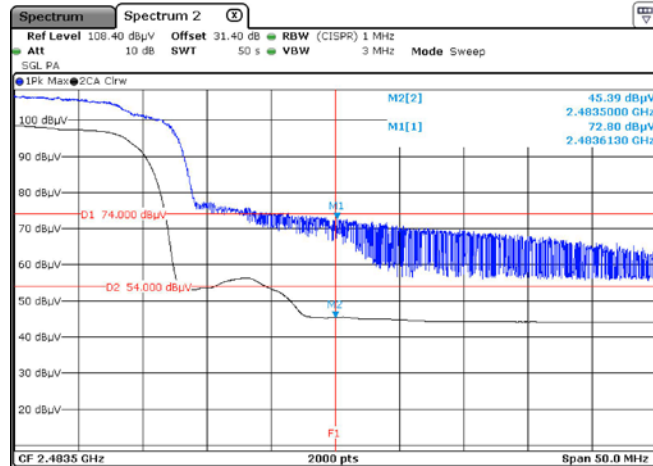

802.11b

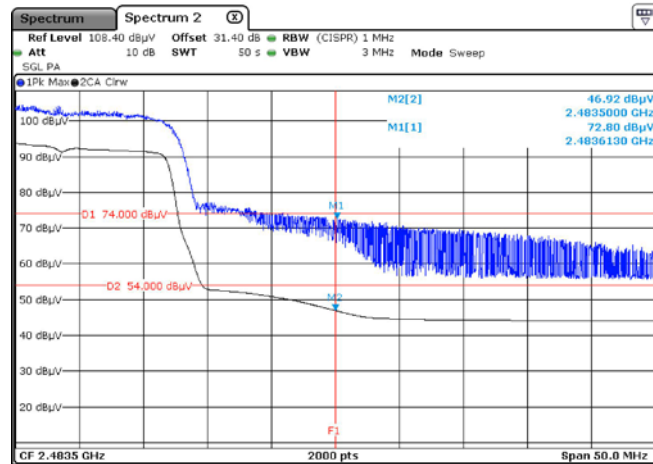

802.11g

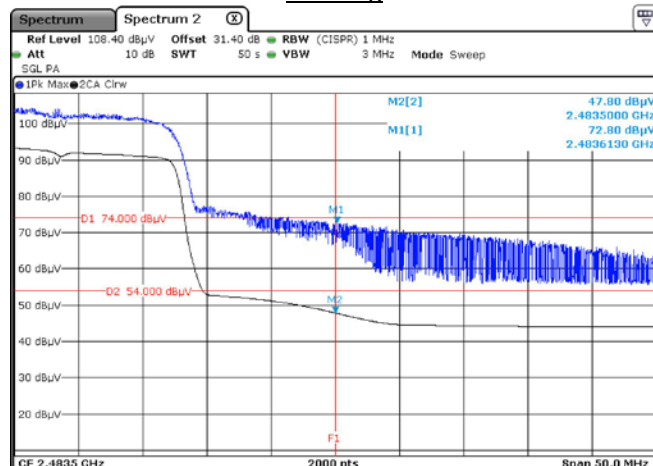

802.11n

High bandedge compliance

RESULT: PASS

Note: radiated measurement (3m in FAC)

Graphical representation of Radiated Disturbance Measurement (Peak detection, Anechoic chamber pre-scan, 30MHz-1GHz / 3m / Horizontal & Vertical/ Transmit mode) – Standalone

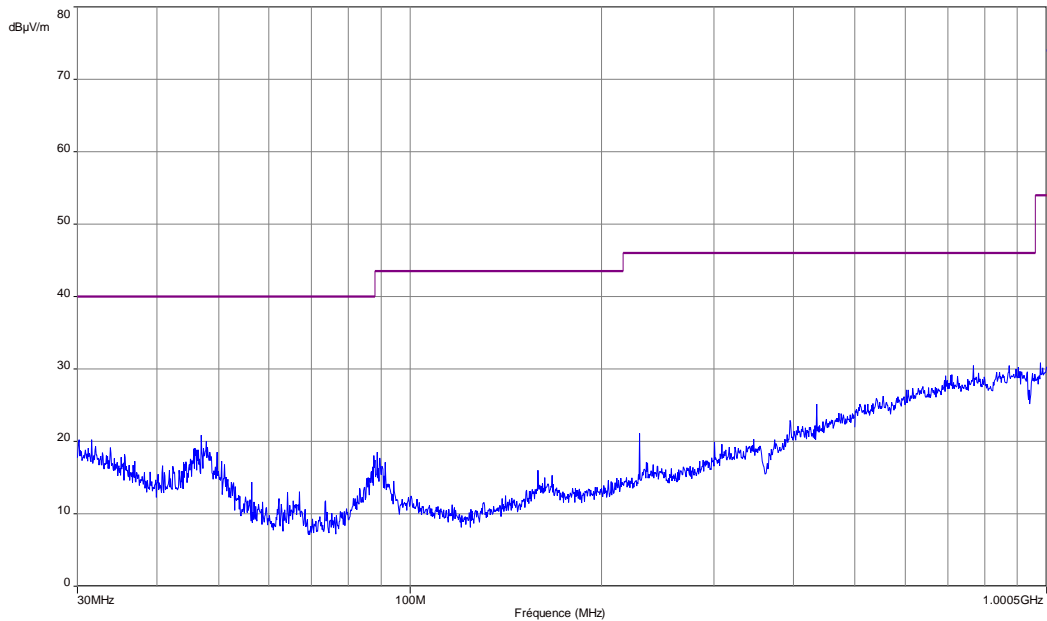
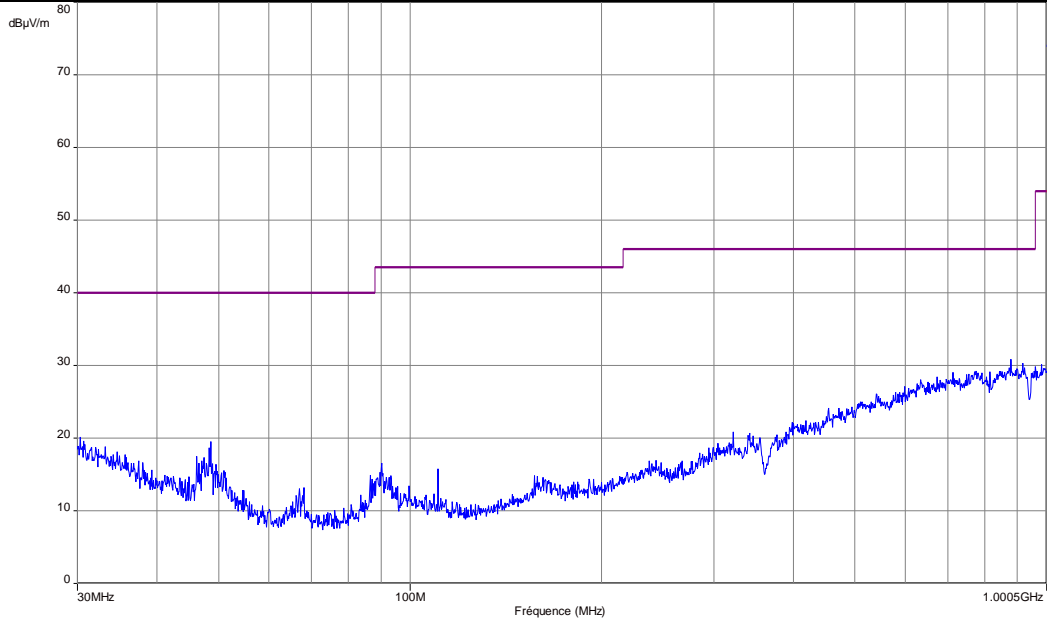

Note: Pre-scan graph only for identification purpose. Worst case between low, mid and high channels.

Frequency band investigated:	30MHz-1GHz
Unit :	dBµV/m
RBW :	100kHz
Antenna polarization :	Horizontal & Vertical
Voltage:	3.7V DC (Internal battery)
Limit:	FCC 15.209 / RSS-GEN
Measurement detector:	Peak
Wide Measurement Uncertainty:	± 5.6dB (k=2)

Graphical representation of Radiated Disturbance Measurement (Peak detection, Anechoic chamber pre-scan, 30MHz-1GHz / 3m / Horizontal & Vertical/ Transmit mode) – Battery charging

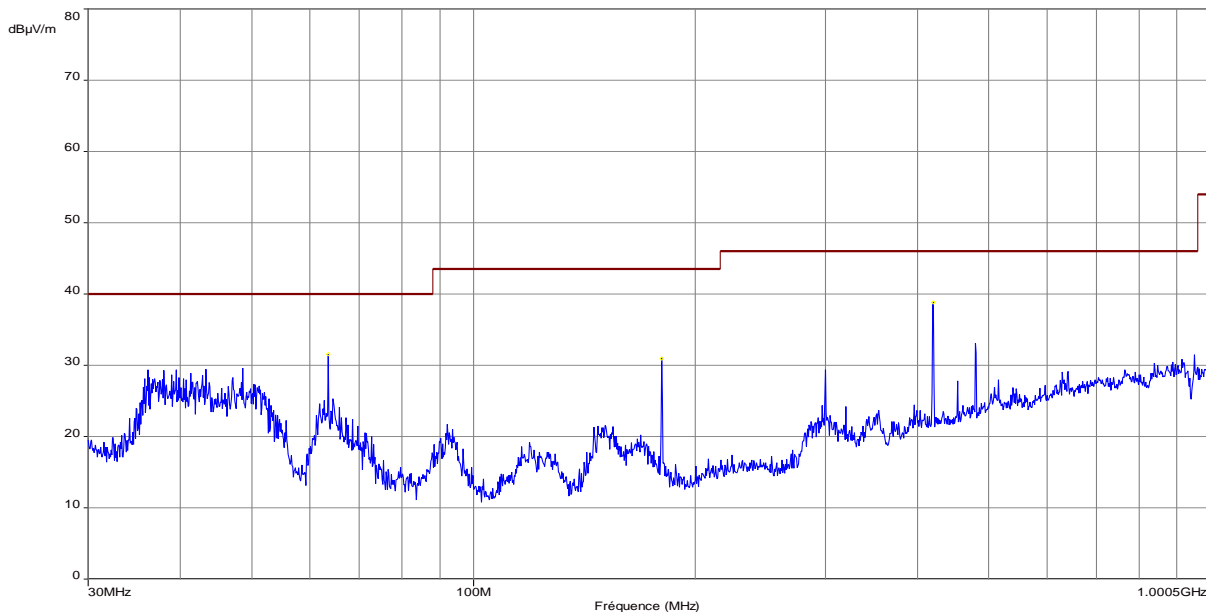
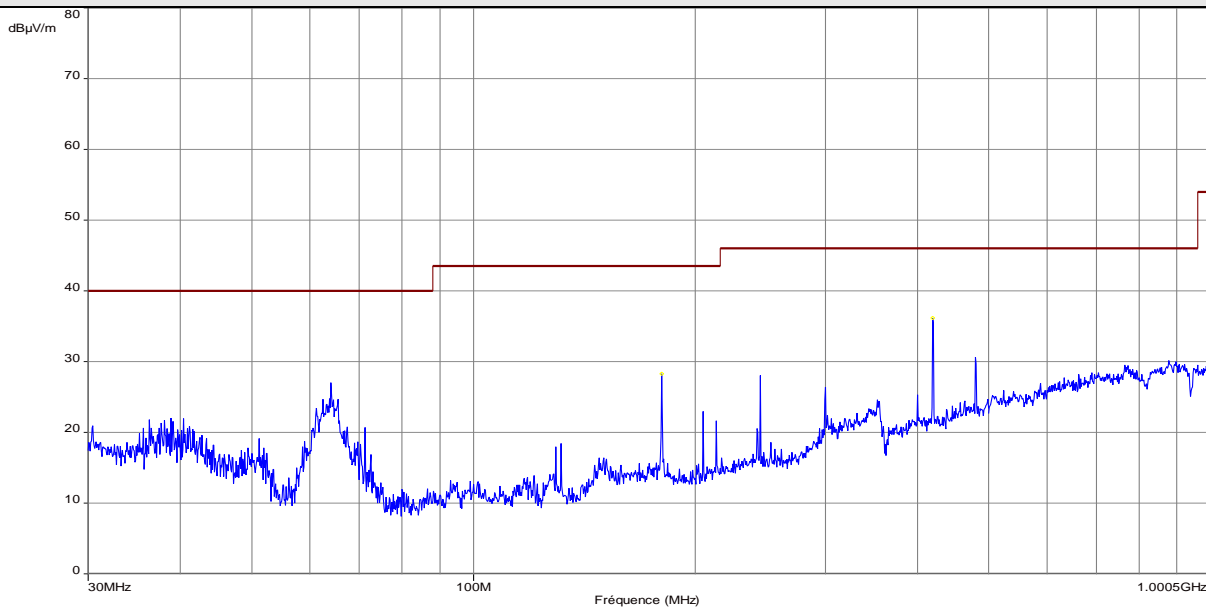

Note: Pre-scan graph only for identification purpose. Worst case between low, mid and high channels.

Frequency band investigated:	30MHz-1GHz
Unit :	dBµV/m
RBW :	100kHz
Antenna polarization :	Horizontal & Vertical
Voltage:	3.7V DC (Internal battery)
Limit:	FCC 15.247 / RSS-247
Measurement detector:	Peak
Wide Measurement Uncertainty:	± 5.6dB (k=2)

Graphical representation of Radiated Disturbance Measurement (Peak detection, Anechoic chamber pre-scan, 1GHz-18GHz / 3m / Horizontal & Vertical / Transmit mode 802.11b / Low channel

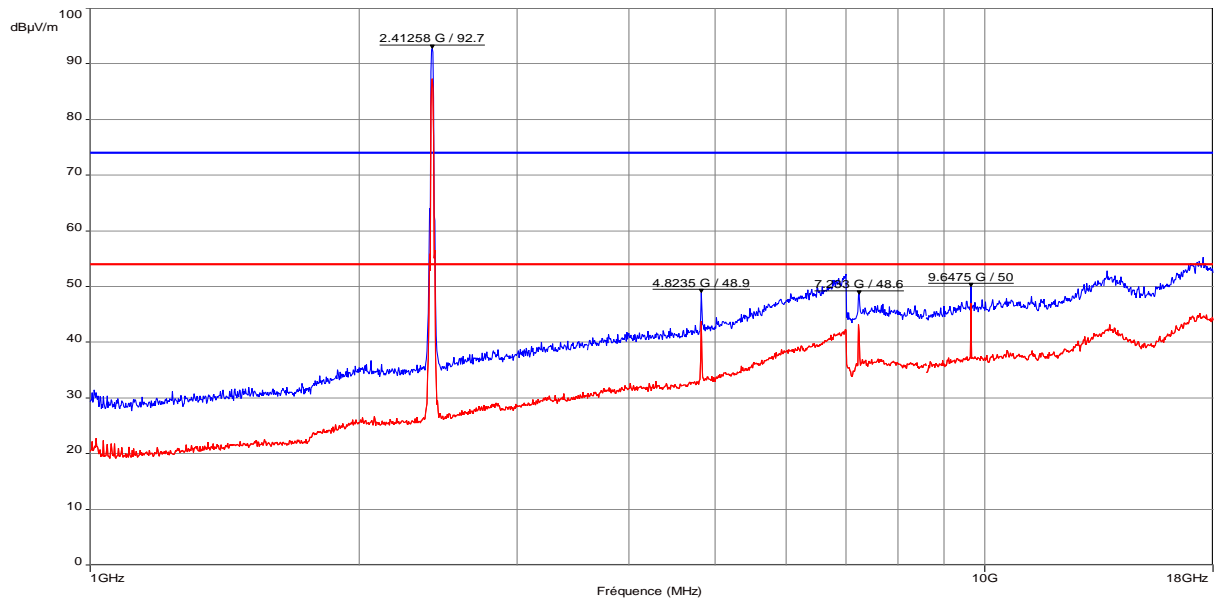
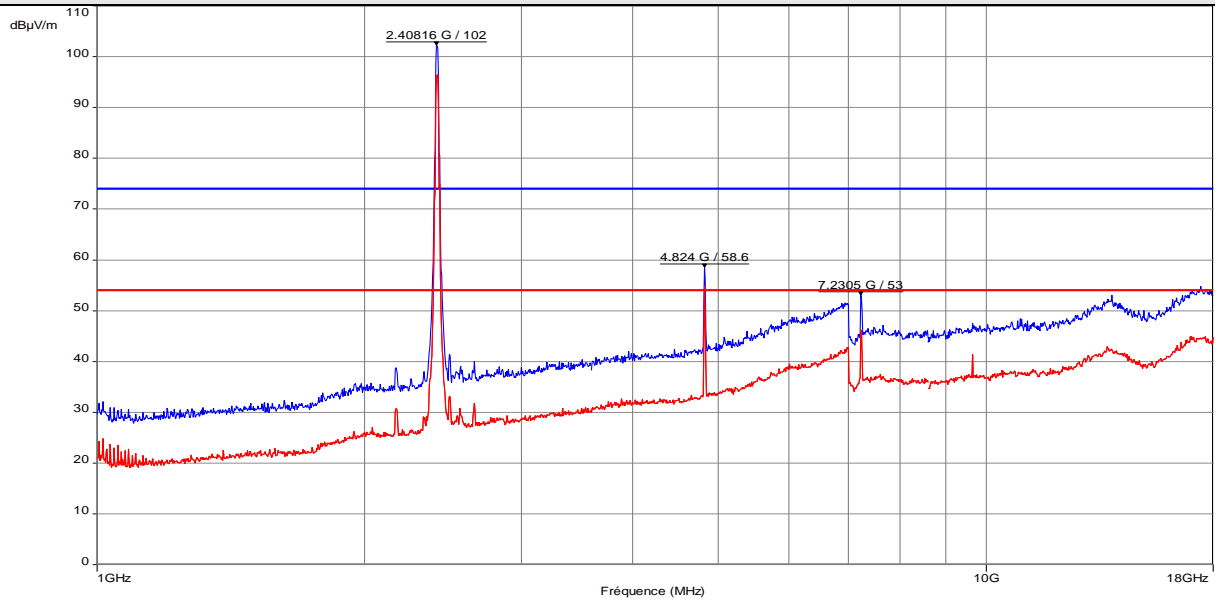

Note: Pre-scan graph only for identification purpose.

----- : Peak measure	----- : Average measure
Frequency band investigated:	1GHz-18GHz
Unit :	dBµV/m
RBW :	1MHz
Antenna polarization :	Horizontal & Vertical
Voltage:	3.7V DC (Normal mode) / Worst case
Limit:	FCC 15.247 / RSS-247
Measurement detector:	Peak / Average
Wide Measurement Uncertainty:	± 5.6dB (k=2)

Graphical representation of Radiated Disturbance Measurement (Peak detection, Anechoic chamber pre-scan, 1GHz-18GHz / 3m / Horizontal & Vertical / Transmit mode 802.11b / Mid channel

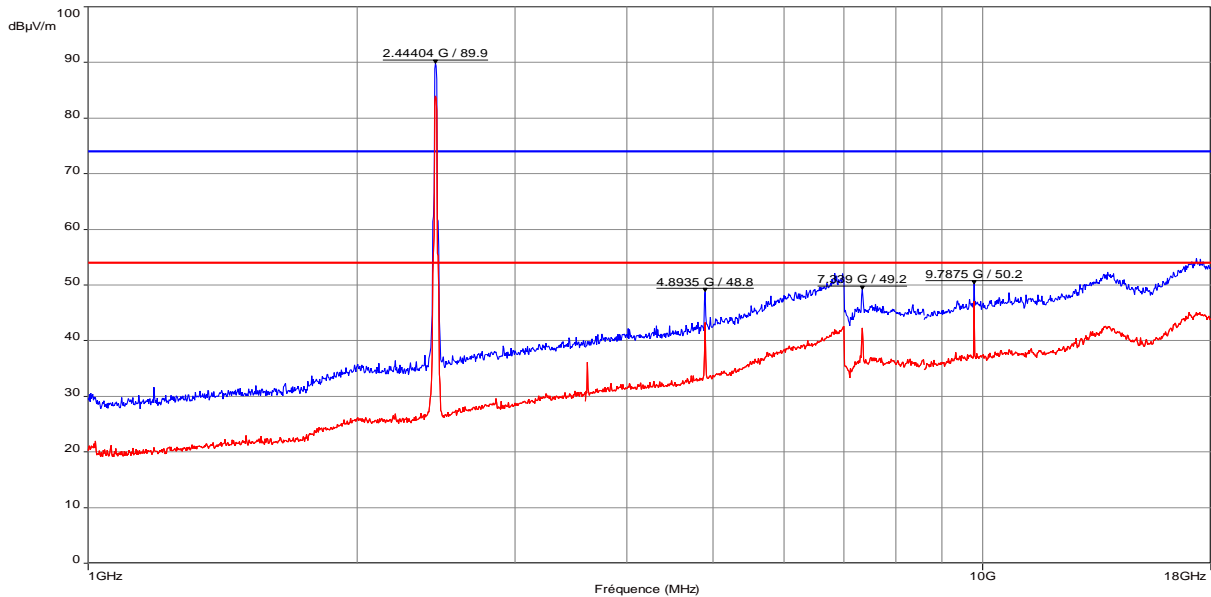
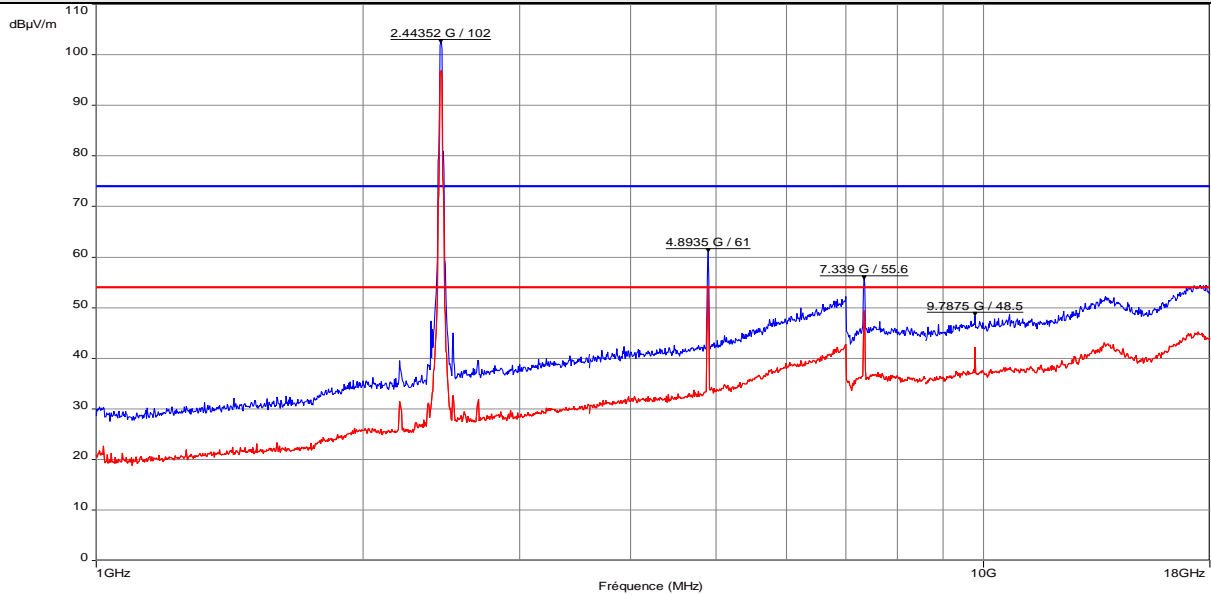

Note: Pre-scan graph only for identification purpose.

----- : Peak measure	----- : Average measure
Frequency band investigated:	1GHz-18GHz
Unit :	dBµV/m
RBW :	1MHz
Antenna polarization :	Horizontal & Vertical
Voltage:	3.7V DC (Normal mode) / Worst case
Limit:	FCC 15.247 / RSS-247
Measurement detector:	Peak / Average
Wide Measurement Uncertainty:	± 5.6dB (k=2)

Graphical representation of Radiated Disturbance Measurement (Peak detection, Anechoic chamber pre-scan, 1GHz-18GHz / 3m / Horizontal & Vertical / Transmit mode 802.11b / High channel

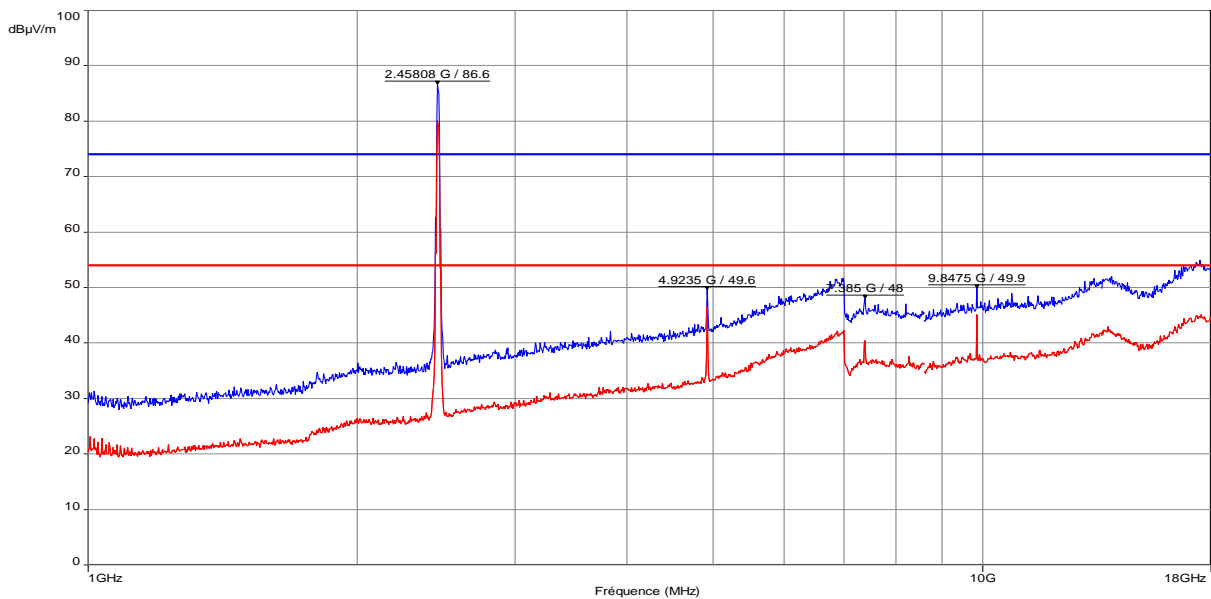
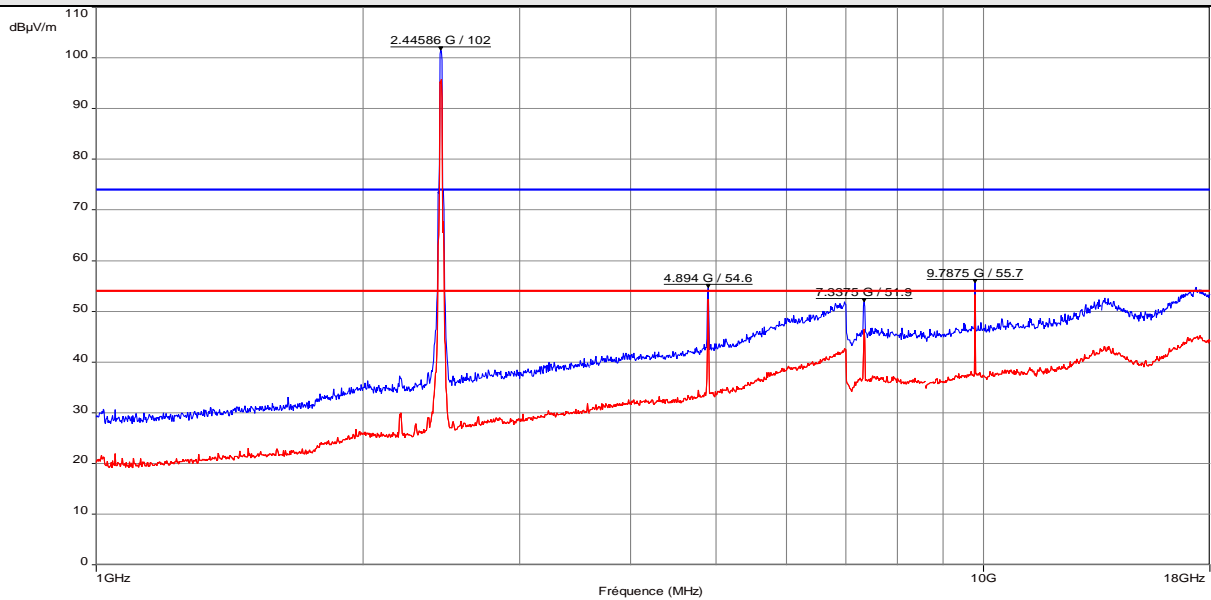

Note: Pre-scan graph only for identification purpose.

----- : Peak measure	----- : Average measure
Frequency band investigated:	1GHz-18GHz
Unit :	dBµV/m
RBW :	1MHz
Antenna polarization :	Horizontal & Vertical
Voltage:	3.7V DC (Normal mode) / Worst case
Limit:	FCC 15.247 / RSS-247
Measurement detector:	Peak / Average
Wide Measurement Uncertainty:	± 5.6dB (k=2)

Graphical representation of Radiated Disturbance Measurement (Peak detection, Anechoic chamber pre-scan, 1GHz-18GHz / 3m / Horizontal & Vertical / Transmit mode 802.11g / Low channel

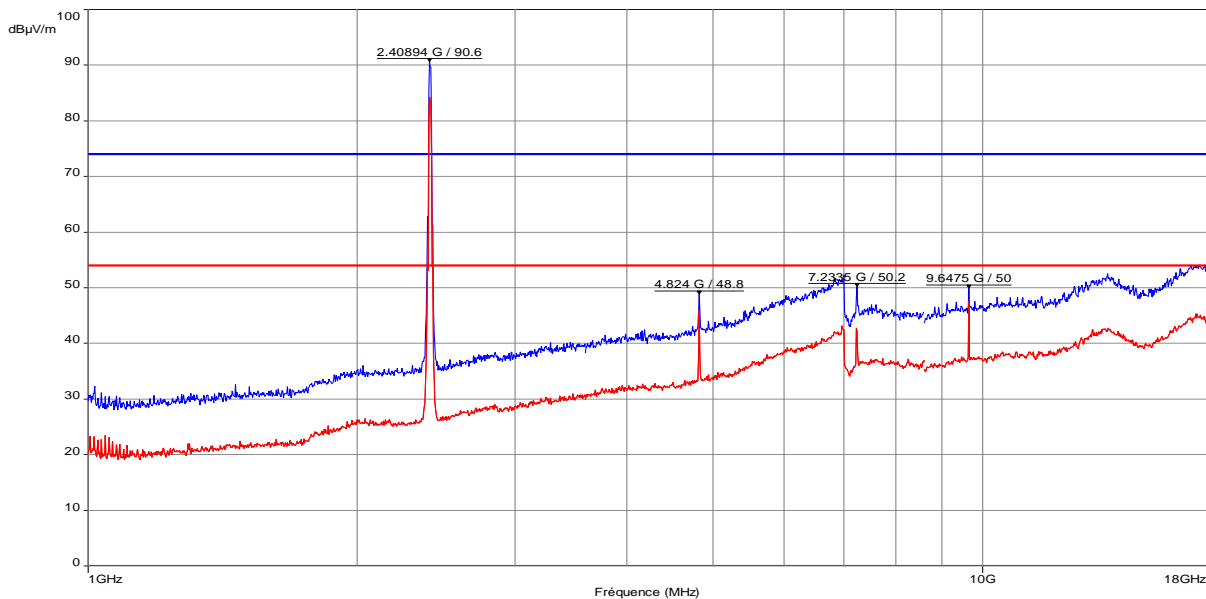
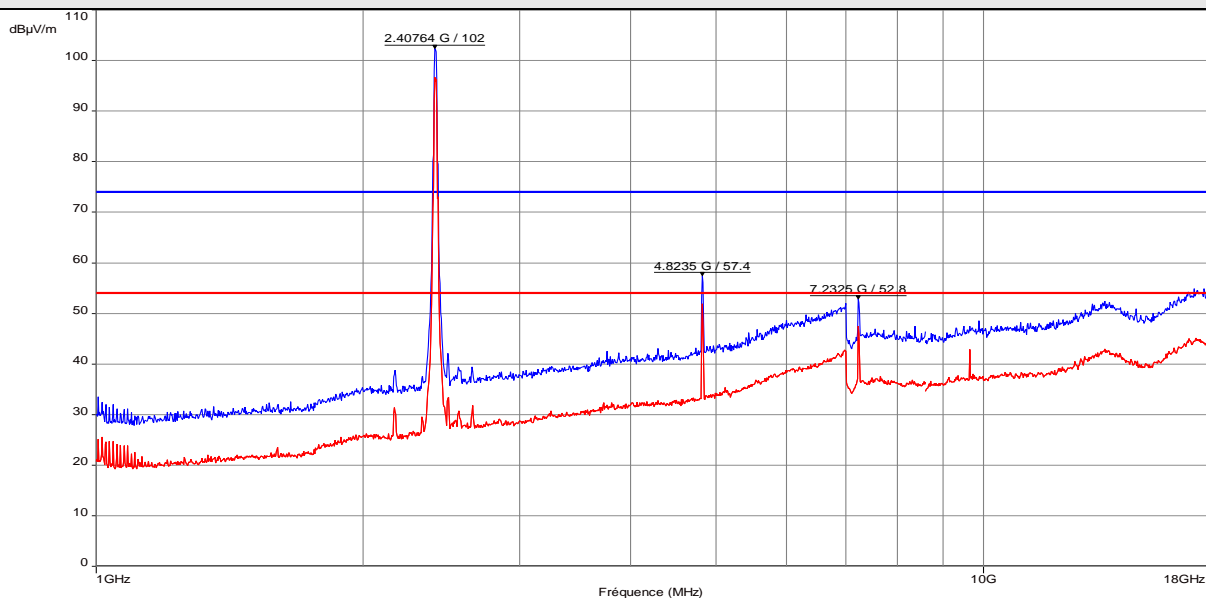

Note: Pre-scan graph only for identification purpose.

----- : Peak measure	----- : Average measure
Frequency band investigated:	1GHz-18GHz
Unit :	dBµV/m
RBW :	1MHz
Antenna polarization :	Horizontal & Vertical
Voltage:	3.7V DC (Normal mode) / Worst case
Limit:	FCC 15.247 / RSS-247
Measurement detector:	Peak / Average
Wide Measurement Uncertainty:	± 5.6dB (k=2)

Graphical representation of Radiated Disturbance Measurement (Peak detection, Anechoic chamber pre-scan, 1GHz-18GHz / 3m / Horizontal & Vertical / Transmit mode 802.11g / Mid channel

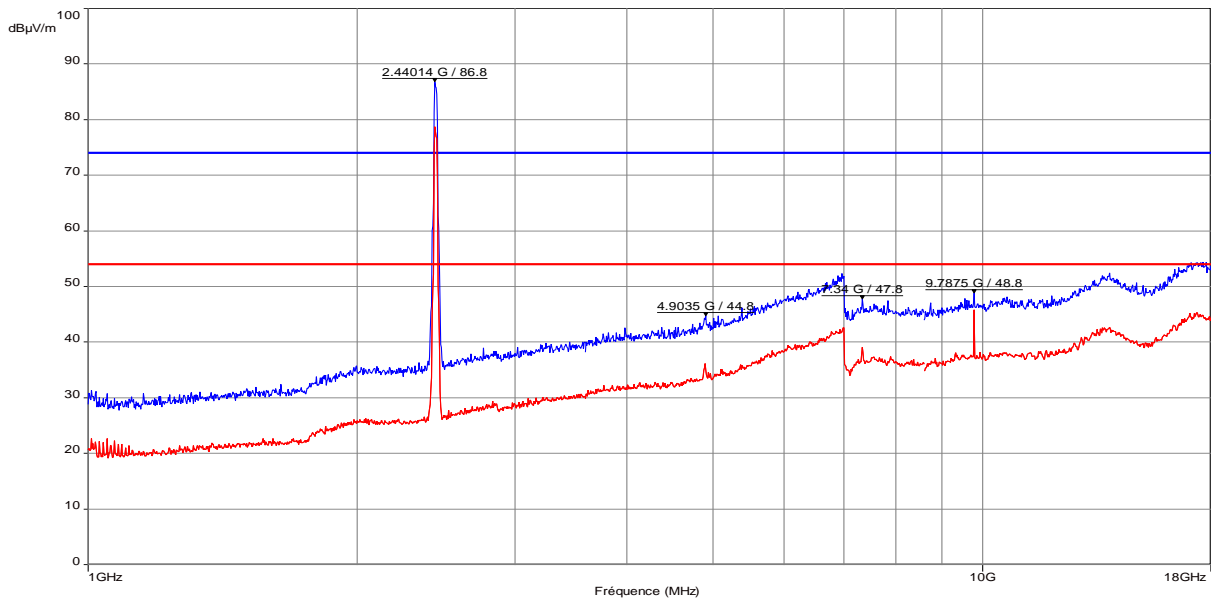
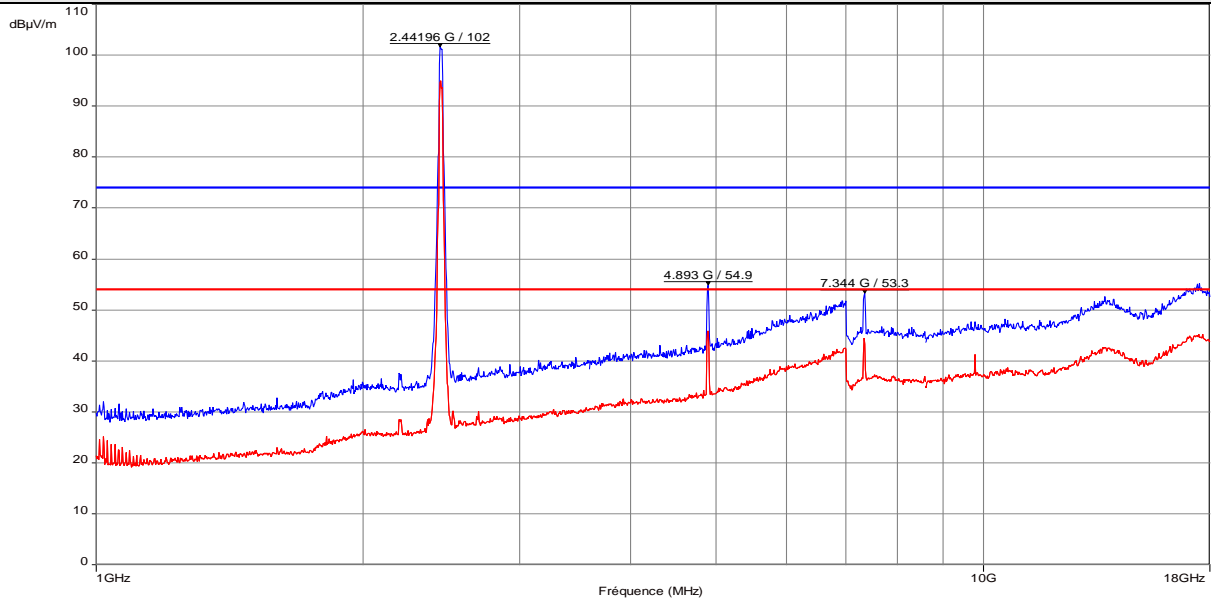

Note: Pre-scan graph only for identification purpose.

----- : Peak measure	----- : Average measure
Frequency band investigated:	1GHz-18GHz
Unit :	dBµV/m
RBW :	1MHz
Antenna polarization :	Horizontal & Vertical
Voltage:	3.7V DC (Normal mode) / Worst case
Limit:	FCC 15.247 / RSS-247
Measurement detector:	Peak / Average
Wide Measurement Uncertainty:	± 5.6dB (k=2)

Graphical representation of Radiated Disturbance Measurement (Peak detection, Anechoic chamber pre-scan, 1GHz-18GHz / 3m / Horizontal & Vertical / Transmit mode 802.11g / High channel

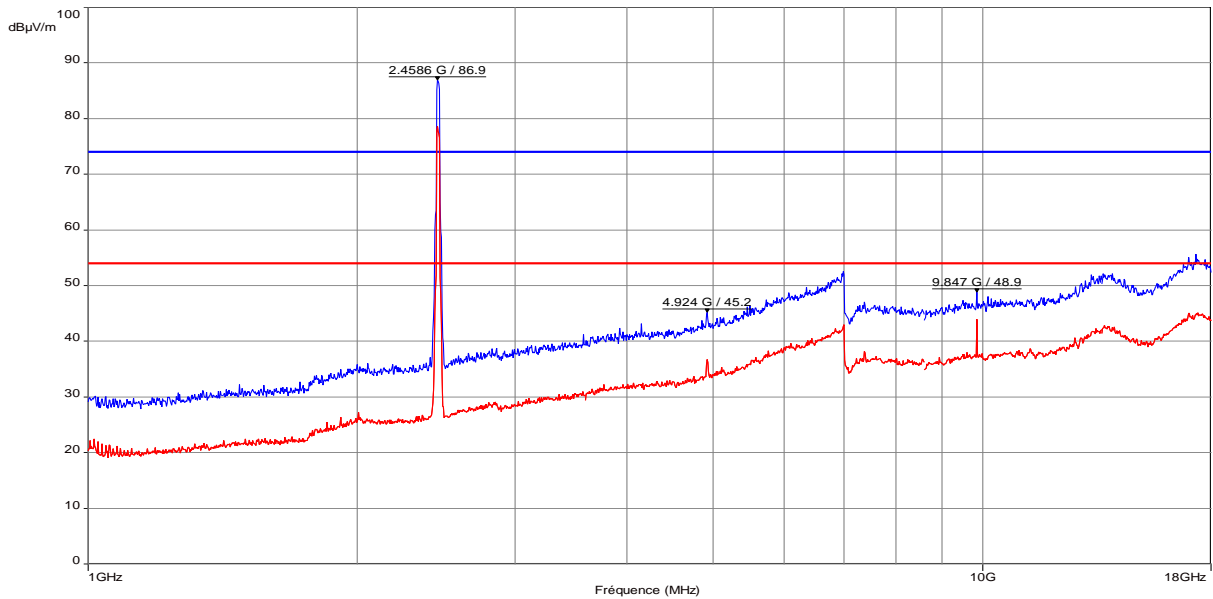
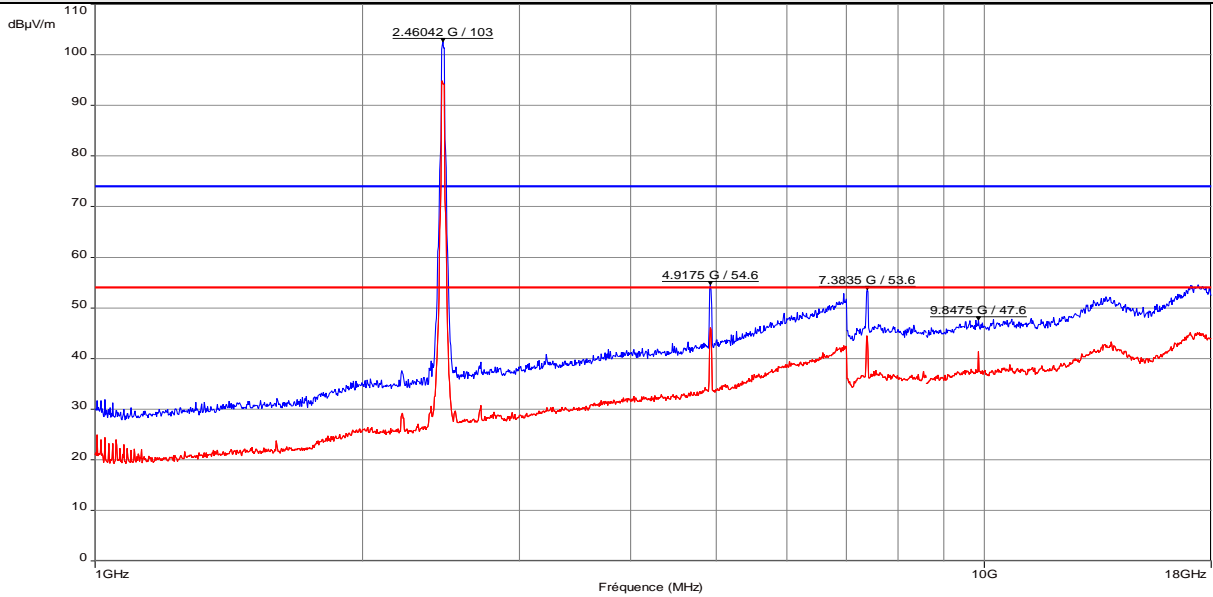

Note: Pre-scan graph only for identification purpose.

----- : Peak measure	----- : Average measure
Frequency band investigated:	1GHz-18GHz
Unit :	dBµV/m
RBW :	1MHz
Antenna polarization :	Horizontal & Vertical
Voltage:	3.7V DC (Normal mode) / Worst case
Limit:	FCC 15.247 / RSS-247
Measurement detector:	Peak / Average
Wide Measurement Uncertainty:	± 5.6dB (k=2)

Graphical representation of Radiated Disturbance Measurement (Peak detection, Anechoic chamber pre-scan, 1GHz-18GHz / 3m / Horizontal & Vertical / Transmit mode 802.11n / Low channel)

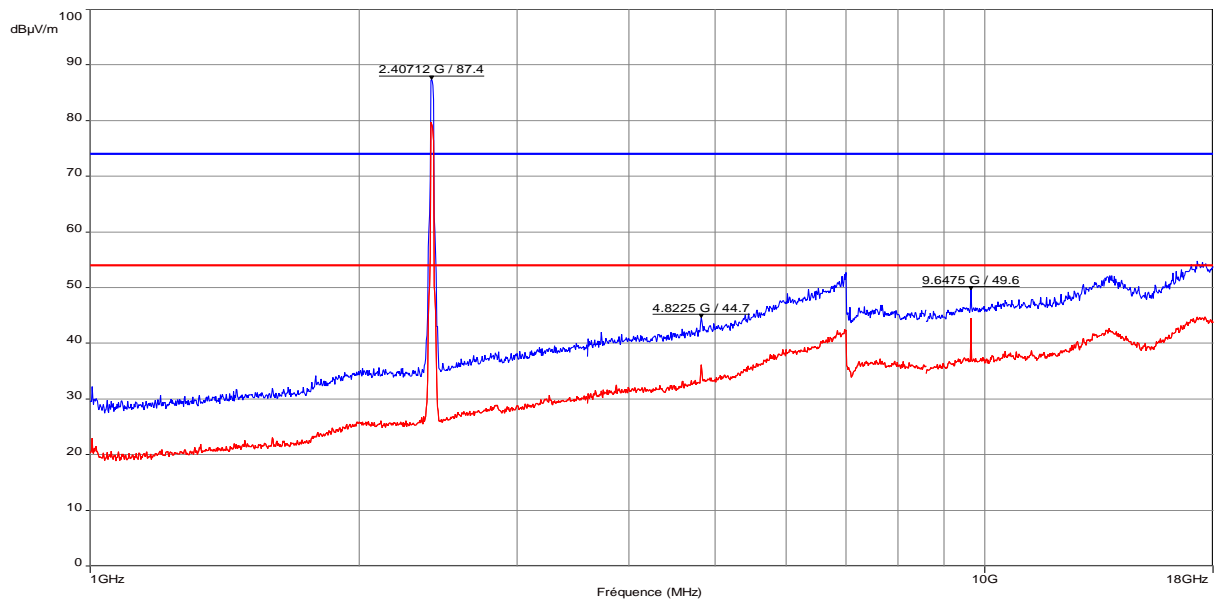
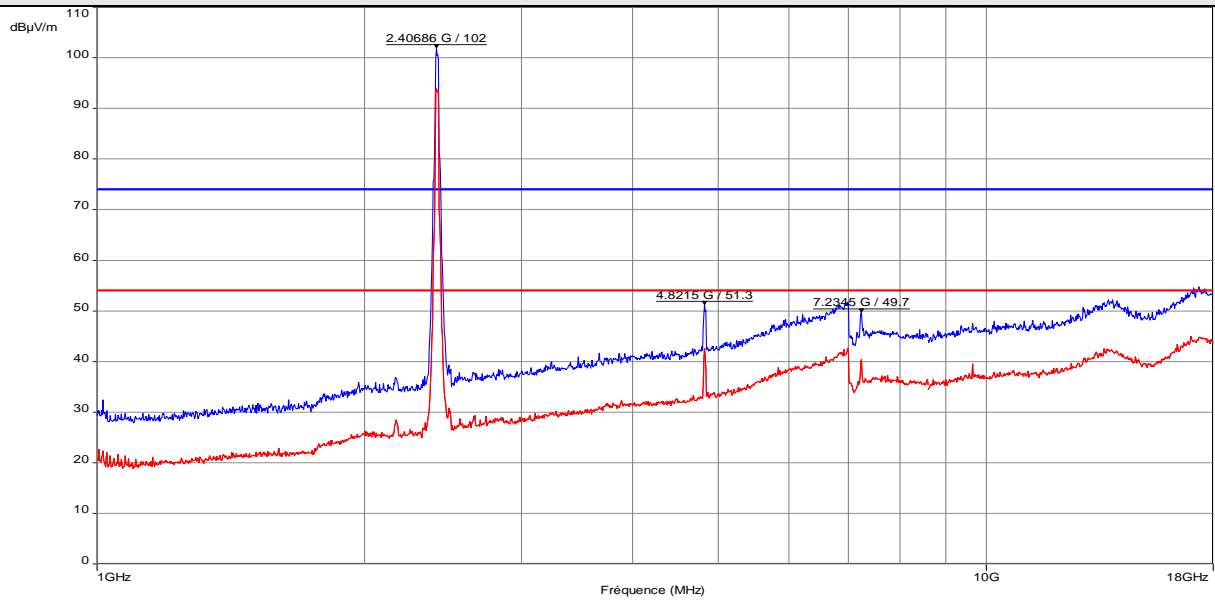

Note: Pre-scan graph only for identification purpose.

----- : Peak measure	----- : Average measure
Frequency band investigated:	1GHz-18GHz
Unit :	dBµV/m
RBW :	1MHz
Antenna polarization :	Horizontal & Vertical
Voltage:	3.7V DC (Normal mode) / Worst case
Limit:	FCC 15.247 / RSS-247
Measurement detector:	Peak / Average
Wide Measurement Uncertainty:	± 5.6dB (k=2)

Graphical representation of Radiated Disturbance Measurement (Peak detection, Anechoic chamber pre-scan, 1GHz-18GHz / 3m / Horizontal & Vertical / Transmit mode 802.11n / Mid channel

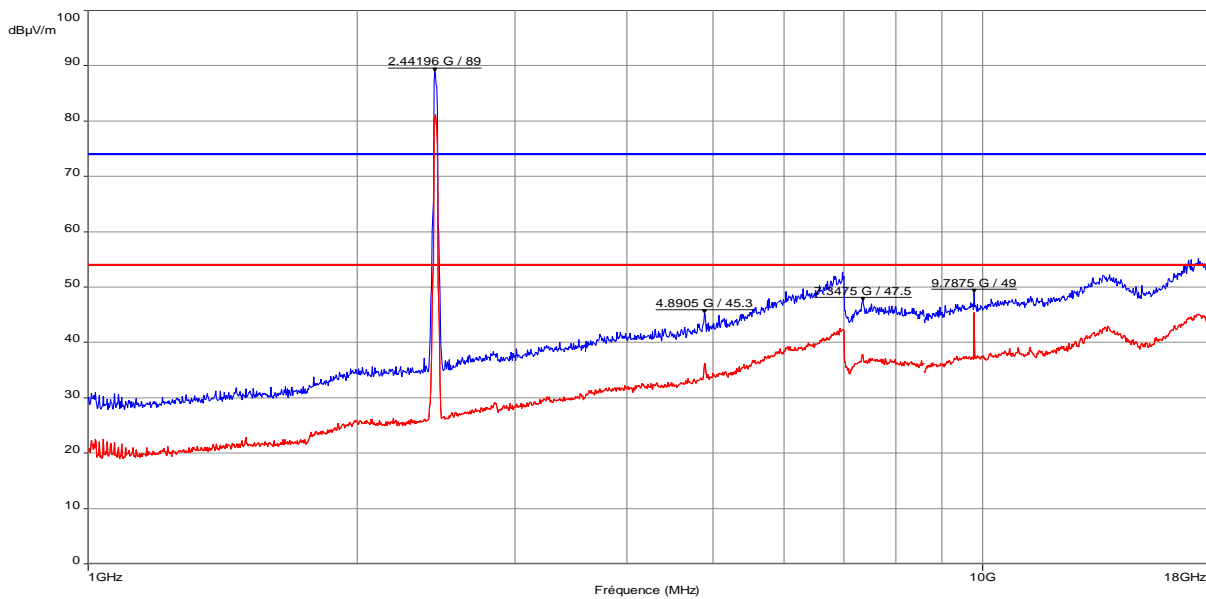
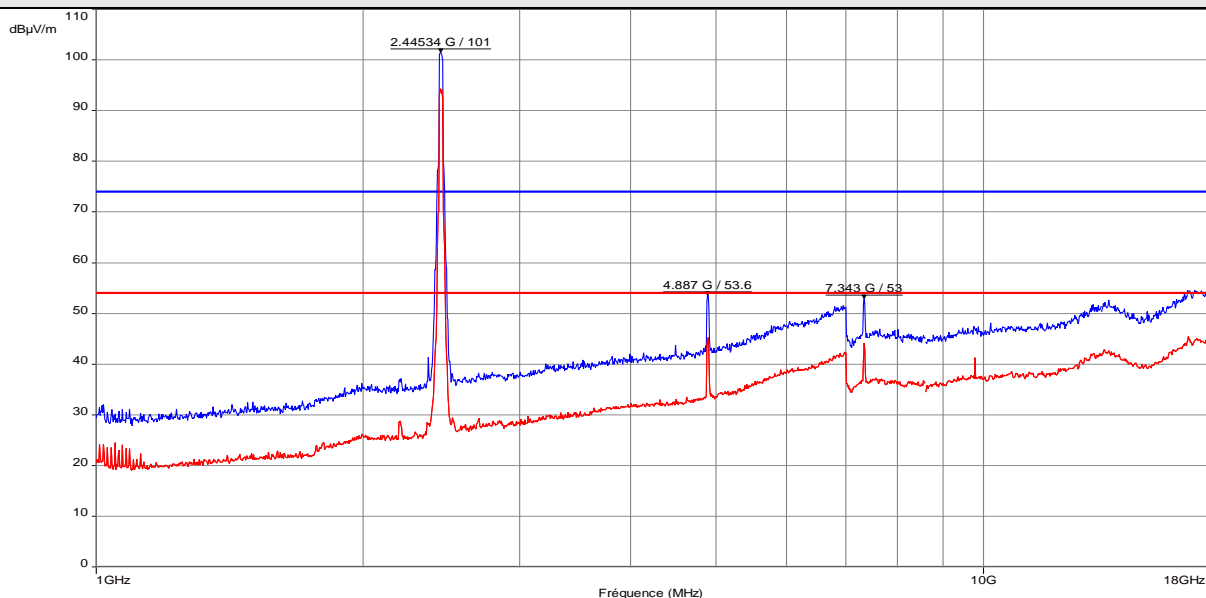

Note: Pre-scan graph only for identification purpose.

----- : Peak measure	----- : Average measure
Frequency band investigated:	1GHz-18GHz
Unit :	dBµV/m
RBW :	1MHz
Antenna polarization :	Horizontal & Vertical
Voltage:	3.7V DC (Normal mode) / Worst case
Limit:	FCC 15.247 / RSS-247
Measurement detector:	Peak / Average
Wide Measurement Uncertainty:	± 5.6dB (k=2)

Graphical representation of Radiated Disturbance Measurement (Peak detection, Anechoic chamber pre-scan, 1GHz-18GHz / 3m / Horizontal & Vertical / Transmit mode 802.11n / High channel)

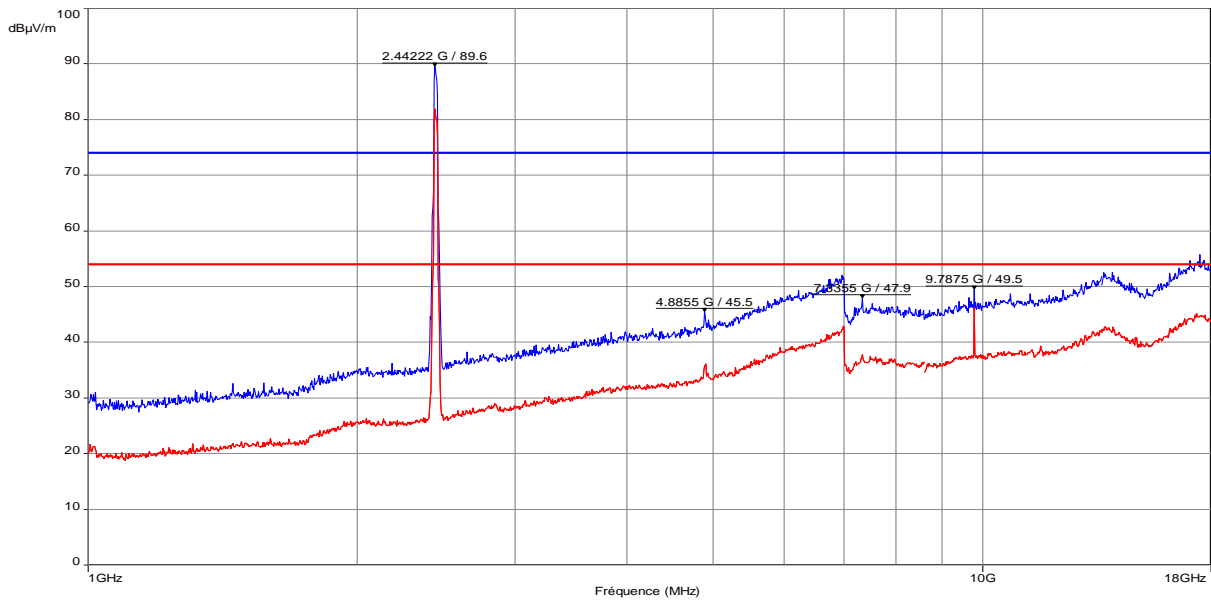
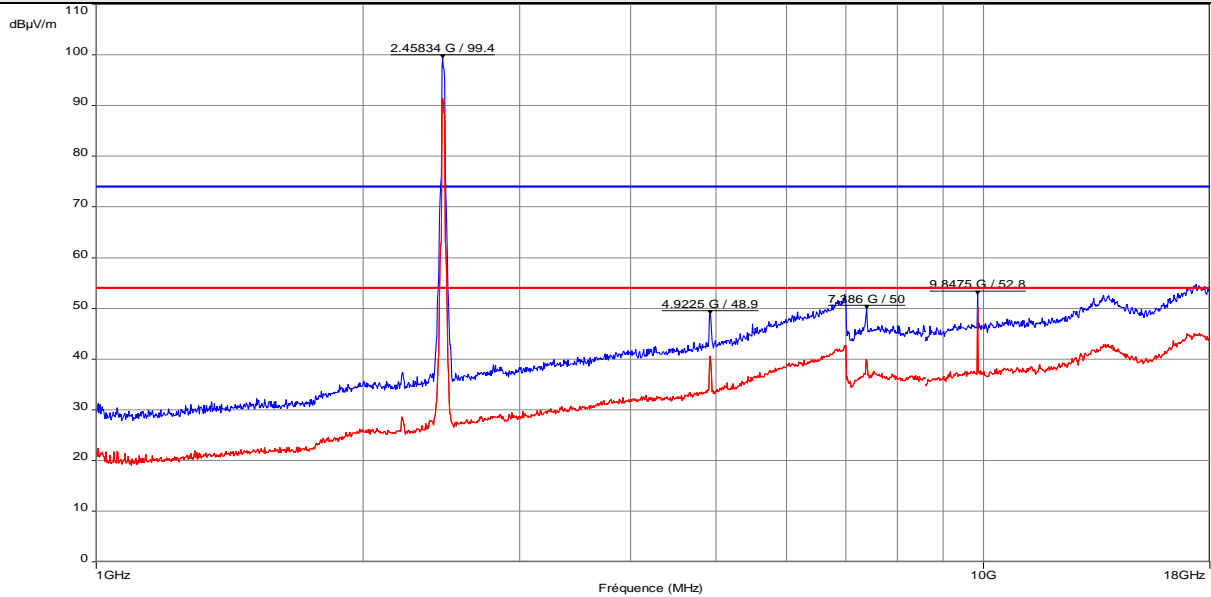

Note: Pre-scan graph only for identification purpose.

----- : Peak measure	----- : Average measure
Frequency band investigated:	1GHz-18GHz
Unit :	dBµV/m
RBW :	1MHz
Antenna polarization :	Horizontal & Vertical
Voltage:	3.7V DC (Normal mode) / Worst case
Limit:	FCC 15.247 / RSS-247
Measurement detector:	Peak / Average
Wide Measurement Uncertainty:	± 5.6dB (k=2)

Graphical representation of Radiated Disturbance Measurement (Peak detection, Anechoic chamber pre-scan, 18GHz-26GHz / 3m / Horizontal & Vertical/ Transmit mode) – 802.11 b/g/n Low, Mid and High channels.

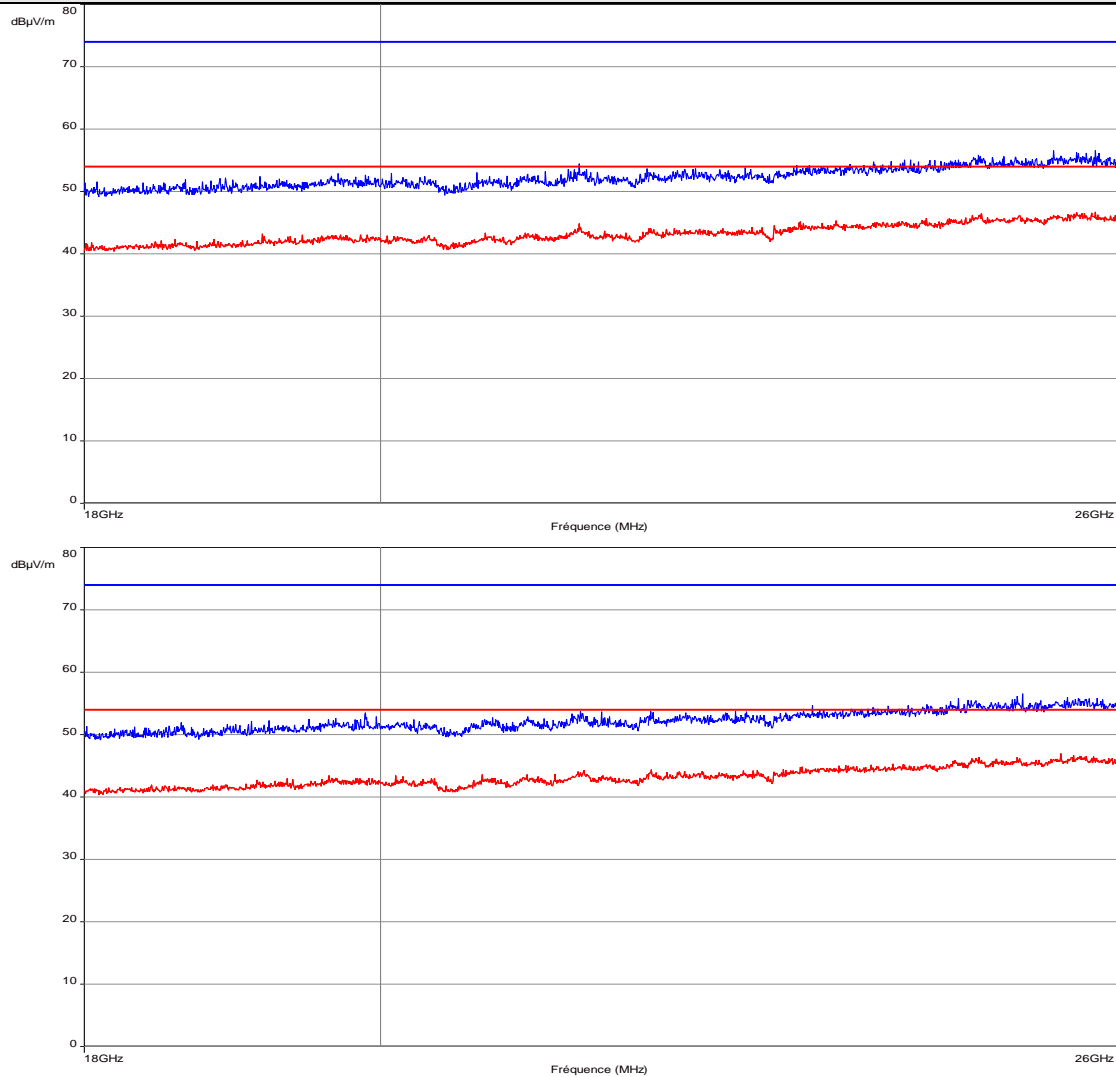

Note: Pre-scan graph only for identification purpose.

----- : Peak measure	----- : Average measure
Frequency band investigated:	18GHz-26GHz
Unit :	dBµV/m
RBW :	1MHz
Antenna polarization :	Horizontal & Vertical
Voltage:	3.7V DC (Normal mode) / Worst case
Limit:	FCC 15.209 / RSS-GEN
Measurement detector:	Peak
Wide Measurement Uncertainty:	± 5dB (k=2)

14. Occupied bandwidth (99%)

TEST: Occupied bandwidth (99%) / RSS-GEN		Verdict
<p>Method: The setup is in an anechoic chamber. The spectrum analyzer is connected to the measuring antenna. A radiated measurement is performed. The RBW is set in the range of 1% to 5% of the occupied bandwidth, with VBW \geq 3 x RBW. The SPAN is wide enough to capture all products of the modulation process. A MaxHold Peak detector is used. Measure is performed with OBW 99% function of the spectrum analyser. The tested equipment is set to transmit operation with modulation on low, mid and high channels.</p>		Pass
Laboratory Parameters:	Required prior to the test	
Ambient Temperature	20 to 30 °C	23°C \pm 2
Relative Humidity	25 to 70 %	64% \pm 5
Supplementary information: Test location: SMEE. Test date: June 8 th , 2018. Tested by L. CHAPUS		

Test Equipment Used					
Description	Manufacturer	Model	Identifier	Cal. Date	Cal. Due
Horn antenna	ETS-LINDGREN	3115	ANT-141-013	2014/3	2019/3
RF cable	Pasternack RF	PE302-120	CAB-131-024	2018/4	2019/4
RF cable	HUBER+SUHNER	SF104	CAB-141-030	2018/4	2019/4
Anechoic chamber	COMTEST	214263	CAG-141-001	2017/6	2020/6
Turntable	Innco- Systems	CT0800	PLA-141-001	-	-
Measuring receiver	Rohde&Schwarz	ESRP	REC-151-003	2017/3	2019/3

Tabulated Results for Occupied Bandwidth	
Frequency (MHz)	99% Occupied Bandwidth (MHz)
802.11b	
2412.0	13.711
2437.0	13.686
2462.0	13.811
802.11g	
2412.0	16.484
2437.0	16.434
2462.0	16.484
802.11n	
2412.0	17.582
2437.0	17.607
2462.0	17.632

Graphical representation of Occupied Bandwidth / 802.11b

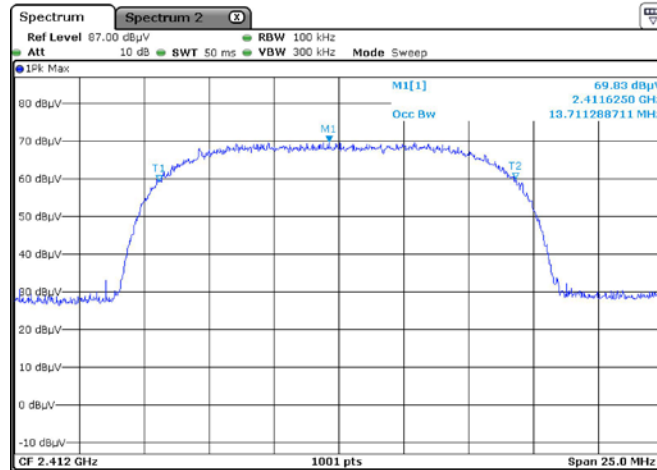

Low Channel

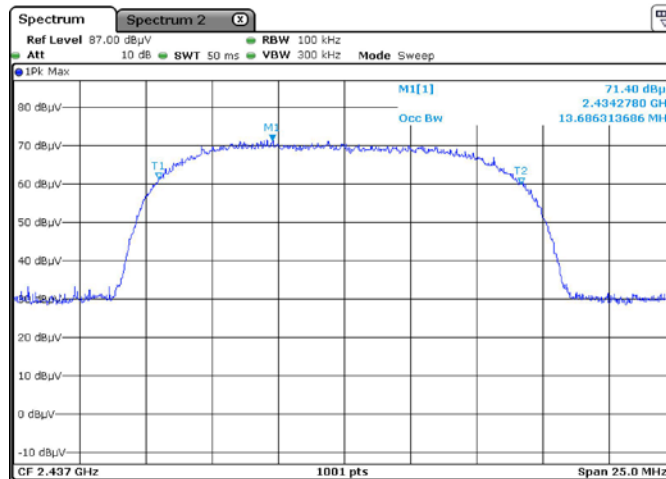

Mid Channel

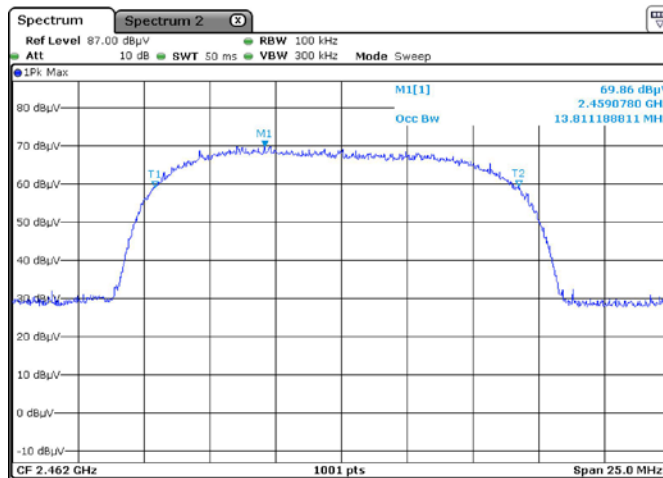

High Channel

RBW :	100kHz
Measurement detector:	Peak

Graphical representation of Occupied Bandwidth / 802.11g

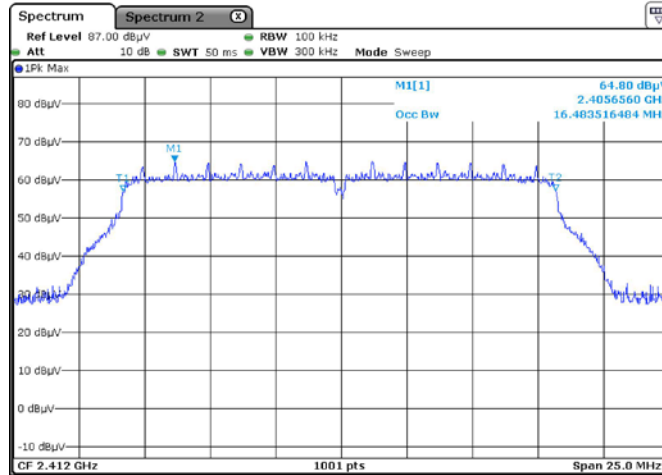

Low Channel

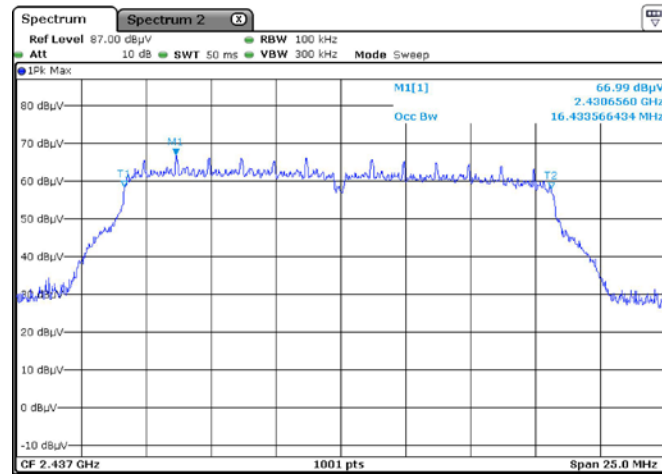

Mid Channel

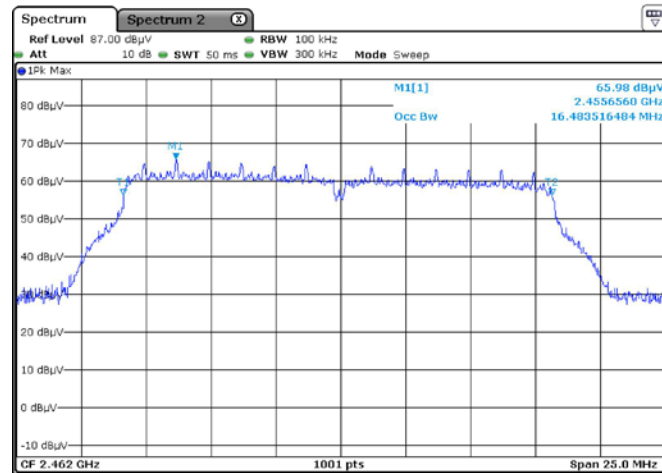

High Channel

RBW :	100kHz
Measurement detector:	Peak

Graphical representation of Occupied Bandwidth / 802.11n

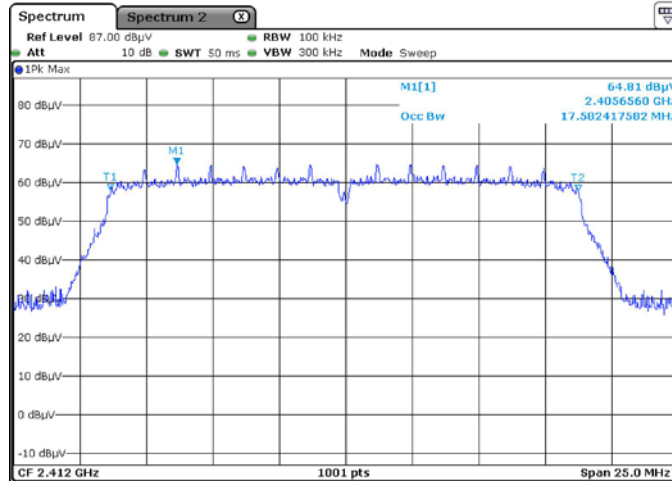

Low Channel

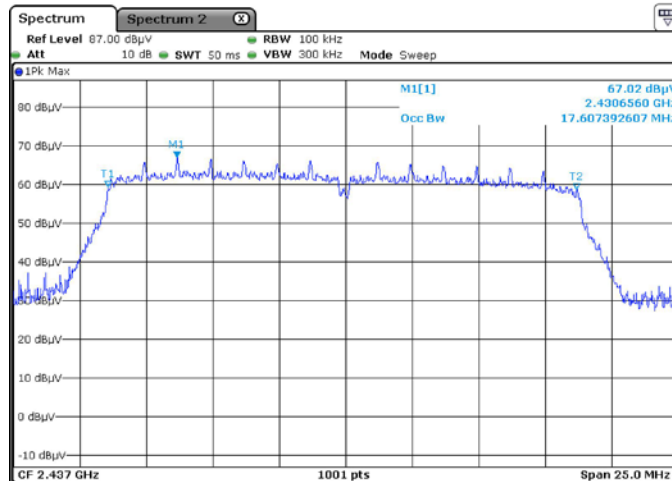

Mid Channel

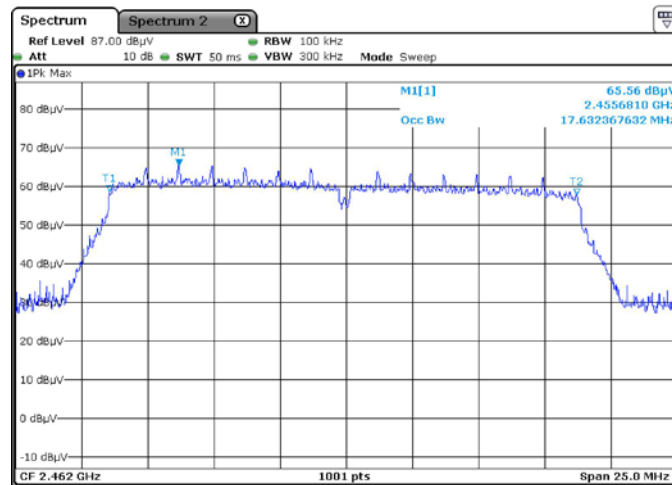

High Channel