



FCC RF Test Report

APPLICANT : Ring LLC
EQUIPMENT : Video Doorbell Pro 2
BRAND NAME : Ring
MODEL NAME : 5AT2S2
FCC ID : 2AEUPBHALP031
STANDARD : FCC Part 15 Subpart E §15.407
CLASSIFICATION : (NII) Unlicensed National Information Infrastructure

The product was received on Sep. 08, 2020 and testing was completed on Nov. 02, 2020. We, Sporton International (Kunshan) Inc., would like to declare that the tested sample has been evaluated in accordance with the test procedures and has been in compliance with the applicable technical standards.

The test results in this report apply exclusively to the tested model / sample. Without written approval of Sporton International (Kunshan) Inc., the test report shall not be reproduced except in full.

Jason Jia

Reviewed by: Jason Jia / Supervisor

James Huang

Approved by: James Huang / Manager



Sporton International (Kunshan) Inc.

**No. 1098, Pengxi North Road, Kunshan Economic Development Zone Jiangsu Province 215300
People's Republic of China**



TABLE OF CONTENTS

REVISION HISTORY.....3

SUMMARY OF TEST RESULT4

1 GENERAL DESCRIPTION5

 1.1 Applicant.....5

 1.2 Manufacturer.....5

 1.3 Product Feature of Equipment Under Test.....5

 1.4 Product Specification of Equipment Under Test.....6

 1.5 Modification of EUT7

 1.6 Testing Location7

 1.7 Test Software.....7

 1.8 Applicable Standards.....8

2 TEST CONFIGURATION OF EQUIPMENT UNDER TEST.....9

 2.1 Carrier Frequency and Channel9

 2.2 Test Mode.....11

 2.3 Connection Diagram of Test System.....13

 2.4 Support Unit used in test configuration and system.....14

 2.5 EUT Operation Test Setup14

 2.6 Measurement Results Explanation Example.....14

3 TEST RESULT.....15

 3.1 26dB & 99% Occupied Bandwidth Measurement15

 3.2 Maximum Conducted Output Power Measurement17

 3.3 Power Spectral Density Measurement19

 3.4 Unwanted Emissions Measurement.....22

 3.5 AC Conducted Emission Measurement.....27

 3.6 Automatically Discontinue Transmission29

 3.7 Antenna Requirements.....30

4 LIST OF MEASURING EQUIPMENT.....31

5 UNCERTAINTY OF EVALUATION.....32

APPENDIX A. CONDUCTED TEST RESULTS

APPENDIX B. AC CONDUCTED EMISSION TEST RESULT

APPENDIX C. RADIATED SPURIOUS EMISSION

APPENDIX D. DUTY CYCLE PLOTS

APPENDIX E. SETUP PHOTOGRAPHS



REVISION HISTORY

REPORT NO.	VERSION	DESCRIPTION	ISSUED DATE
FR090815G	Rev. 01	Initial issue of report	Jan. 11, 2021



SUMMARY OF TEST RESULT

Report Section	FCC Rule	Description	Limit	Result	Remark
3.1	2.1049 & 15.403(i)	26dB & 99% Bandwidth	-	Pass	-
3.2	15.407(a)	Maximum Conducted Output Power	≤ 24 dBm	Pass	-
3.3	15.407(a)	Power Spectral Density	≤ 11 dBm	Pass	-
3.4	15.407(b)	Unwanted Emissions	15.407(b) & 15.209(a)	Pass	Under limit 3.3 dB at 5468.240 MHz
3.5	15.207	AC Conducted Emission	15.207(a)	Pass	Under limit 22.39 dB at 16.839 MHz
3.6	15.407(c)	Automatically Discontinue Transmission	Discontinue Transmission	Pass	-
3.7	15.203 & 15.407(a)	Antenna Requirement	N/A	Pass	-

Declaration of Conformity:
The test results with all measurement uncertainty excluded are presented in accordance with the regulation limits or requirements declared by manufacturers.
Comments and Explanations:
The declared of product specification for EUT presented in the report are provided by the manufacturer, and the manufacturer takes all the responsibilities for the accuracy of product specification.



1 General Description

1.1 Applicant

Ring LLC
1523 26th St, Santa Monica, CA 90404, USA

1.2 Manufacturer

Goertek Inc.
No.268 Dongfang Road High-Tech Industrial Development District, Weifang Shandong, China

1.3 Product Feature of Equipment Under Test

Product Feature	
Equipment	Video Doorbell Pro 2
Brand Name	Ring
Model Name	5AT2S2
FCC ID	2AEUPBHALP031
EUT supports Radios application	WLAN 2.4GHz 802.11b/g/n HT20 WLAN 5GHz 802.11a/n HT20/HT40 WLAN 5GHz 802.11ac VHT20/VHT40/VHT80 Bluetooth BR/EDR/LE LoRa DTS/LoRa FHSS/FSK FHSS/Radar
HW Version	R6
SW Version	7.1.61
EUT Stage	Production Unit

Remark: The above EUT's information was declared by manufacturer. Please refer to the specifications or user's manual for more detailed description.



1.4 Product Specification of Equipment Under Test

Standards-related Product Specification	
Tx/Rx Frequency Range	5180 MHz ~ 5240 MHz 5260 MHz ~ 5320 MHz 5500 MHz ~ 5720 MHz
Maximum Output Power to Antenna	<p><MIMO Ant.1+2> <5180 MHz ~ 5240 MHz> 802.11a : 20.56 dBm / 0.1138 W 802.11ac VHT20 : 20.69 dBm / 0.1172 W 802.11ac VHT40 : 21.71 dBm / 0.1483 W 802.11ac VHT80 : 15.74 dBm / 0.0375 W <5260 MHz ~ 5320 MHz> 802.11a : 20.53 dBm / 0.1130 W 802.11ac VHT20 : 20.75 dBm / 0.1189 W 802.11ac VHT40 : 21.58 dBm / 0.1439 W 802.11ac VHT80 : 15.52 dBm / 0.0356 W <5500 MHz ~ 5720 MHz > 802.11a : 20.54 dBm / 0.1132 W 802.11ac VHT20 : 20.61 dBm / 0.1151 W 802.11ac VHT40 : 21.40 dBm / 0.1380 W 802.11ac VHT80 : 21.41 dBm / 0.1384 W</p>
99% Occupied Bandwidth	<p><MIMO Ant.1+2> <5180 MHz ~ 5240 MHz> 802.11a : 17.38 MHz 802.11ac VHT20 : 18.23 MHz 802.11ac VHT40 : 36.36 MHz 802.11ac VHT80 : 75.52 MHz <5260 MHz ~ 5320 MHz> 802.11a : 17.38 MHz 802.11ac VHT20 : 18.28 MHz 802.11ac VHT40 : 36.36 MHz 802.11ac VHT80 : 75.40 MHz <5500 MHz ~ 5720 MHz > 802.11a : 17.58 MHz 802.11ac VHT20 : 18.34 MHz 802.11ac VHT40 : 36.46 MHz 802.11ac VHT80 : 75.52 MHz</p>
Antenna Type / Gain	<p><5180 MHz ~ 5240 MHz> <Ant. 1> : Loop Antenna with gain 4.22 dBi <Ant. 2> : Loop Antenna with gain 4.15 dBi <5260 MHz ~ 5320 MHz> <Ant. 1> : Loop Antenna with gain 4.79 dBi <Ant. 2> : Loop Antenna with gain 4.24 dBi <5500 MHz ~ 5720 MHz> <Ant. 1> : Loop Antenna with gain 4.36 dBi <Ant. 2> : Loop Antenna with gain 4.98 dBi</p>
Type of Modulation	802.11a/n : OFDM (BPSK / QPSK / 16QAM / 64QAM) 802.11ac : OFDM (BPSK / QPSK / 16QAM / 64QAM / 256QAM)



Antenna Function Description		Ant. 1	Ant. 2
	802.11 a/n/ac SISO/MIMO	V	V

1. For 802.11n HT20 / ac VHT20 and 802.11n HT40 / ac VHT40 mode, the whole testing have assessed only 802.11ac VHT20/ VHT40 by referring to their maximum conducted power.
2. For WLAN SISO & MIMO mode, the whole testing has assessed only MIMO mode by referring to the higher normal conducted power.

1.5 Modification of EUT

No modifications are made to the EUT during all test items.

1.6 Testing Location

Sporton International (Kunshan) Inc. is accredited to ISO/IEC 17025:2017 by American Association for Laboratory Accreditation with Certificate Number 5145.02.

Test Firm	Sporton International (Kunshan) Inc.		
Test Site Location	No. 1098, Pengxi North Road, Kunshan Economic Development Zone Jiangsu Province 215300 People's Republic of China TEL : +86-512-57900158 FAX : +86-512-57900958		
Test Site No.	Sporton Site No.	FCC Designation No.	FCC Test Firm Registration No.
	CO01-KS 03CH06-KS TH01-KS	CN1257	314309

1.7 Test Software

Item	Site	Manufacture	Name	Version
1.	03CH06-KS	AUDIX	E3	6.2009-8-24al
2.	CO01-KS	AUDIX	E3	6.2009-8-24



1.8 Applicable Standards

According to the specifications of the manufacturer, the EUT must comply with the requirements of the following standards:

- ♦ 47 CFR Part 15 Subpart E
- ♦ FCC KDB 789033 D02 General UNII Test Procedures New Rules v02r01.
- ♦ FCC KDB 662911 D01 Multiple Transmitter Output v02r01.
- ♦ ANSI C63.10-2013

Remark:

1. All test items were verified and recorded according to the standards and without any deviation during the test.
2. This EUT has also been tested and complied with the requirements of FCC Part 15, Subpart B, recorded in a separate test report.



2 Test Configuration of Equipment Under Test

- a. The EUT has been associated with peripherals and configuration operated in a manner tended to maximize its emission characteristics in a typical application. Frequency range investigated: conduction emission (150 kHz to 30 MHz), radiation emission (9 kHz to the 10th harmonic of the highest fundamental frequency or to 40 GHz, whichever is lower). For radiated measurement, pre-scanned in three orthogonal panels, X, Y, Z. The worst cases (Y plane) were recorded in this report.
- b. AC power line Conducted Emission was tested under maximum output power.

2.1 Carrier Frequency and Channel

Frequency Band	Channel	Freq. (MHz)	Channel	Freq. (MHz)
5180-5240 MHz Band 1 (U-NII-1)	36	5180	44	5220
	38*	5190	46*	5230
	40	5200	48	5240
	42#	5210		

Frequency Band	Channel	Freq. (MHz)	Channel	Freq. (MHz)
5260-5320 MHz Band 2 (U-NII-2A)	52	5260	60	5300
	54*	5270	62*	5310
	56	5280	64	5320
	58#	5290		

Frequency Band	Channel	Freq. (MHz)	Channel	Freq. (MHz)
5500-5720 MHz Band 3 (U-NII-2C)	100	5500	112	5560
	102*	5510	116	5580
	104	5520	132	5660
	106#	5530	134*	5670
	108	5540	136	5680
	110*	5550	140	5700



Frequency Band	Channel	Freq. (MHz)	Channel	Freq. (MHz)
TDWR Channel	118*	5590	124	5620
	120	5600	126*	5630
	122 [#]	5610	128	5640

Frequency Band	Channel	Freq. (MHz)	Channel	Freq. (MHz)
Straddle Channel	138 [#]	5690	144	5720
	142*	5710		

Note:

1. The above Frequency and Channel in "*" were 802.11n HT40 and 802.11ac VHT40.
2. The above Frequency and Channel in "[#]" were 802.11ac VHT80.



2.2 Test Mode

Final test modes are considering the modulation and worse data rates as below table.

MIMO Mode

Modulation	Data Rate
802.11a	6 Mbps
802.11ac VHT20	MCS0
802.11ac VHT40	MCS0
802.11ac VHT80	MCS0

Test Cases	
AC Conducted Emission	Mode 1 : Lora Tx + Bluetooth Link + WLAN Link(5G) + charging from adaptor + 24G Radar Tx
Remark: For Radiated Test Cases, The tests were performed with Adapter.	



Ch. #		Band I : 5180-5240 MHz	Band II : 5260-5320 MHz	Band III : 5500-5720MHz
		802.11a	802.11a	802.11a
L	Low	36	52	100
M	Middle	44	60	116
H	High	48	64	140
Straddle		-	-	144

Ch. #		Band I : 5180-5240 MHz	Band II : 5260-5320 MHz	Band III : 5500-5720MHz
		802.11ac VHT20	802.11ac VHT20	802.11ac VHT20
L	Low	36	52	100
M	Middle	44	60	116
H	High	48	64	140
Straddle		-	-	144

Ch. #		Band I : 5180-5240 MHz	Band II : 5260-5320 MHz	Band III : 5500-5720MHz
		802.11ac VHT40	802.11ac VHT40	802.11ac VHT40
L	Low	38	54	102
M	Middle	-	-	110
H	High	46	62	134
Straddle		-	-	142

Ch. #		Band I : 5180-5240 MHz	Band II : 5260-5320 MHz	Band III : 5500-5720MHz
		802.11ac VHT80	802.11ac VHT80	802.11ac VHT80
L	Low	-	-	106
M	Middle	42	58	-
H	High	-	-	122
Straddle		-	-	138

2.3 Connection Diagram of Test System

For Radiated Emission:

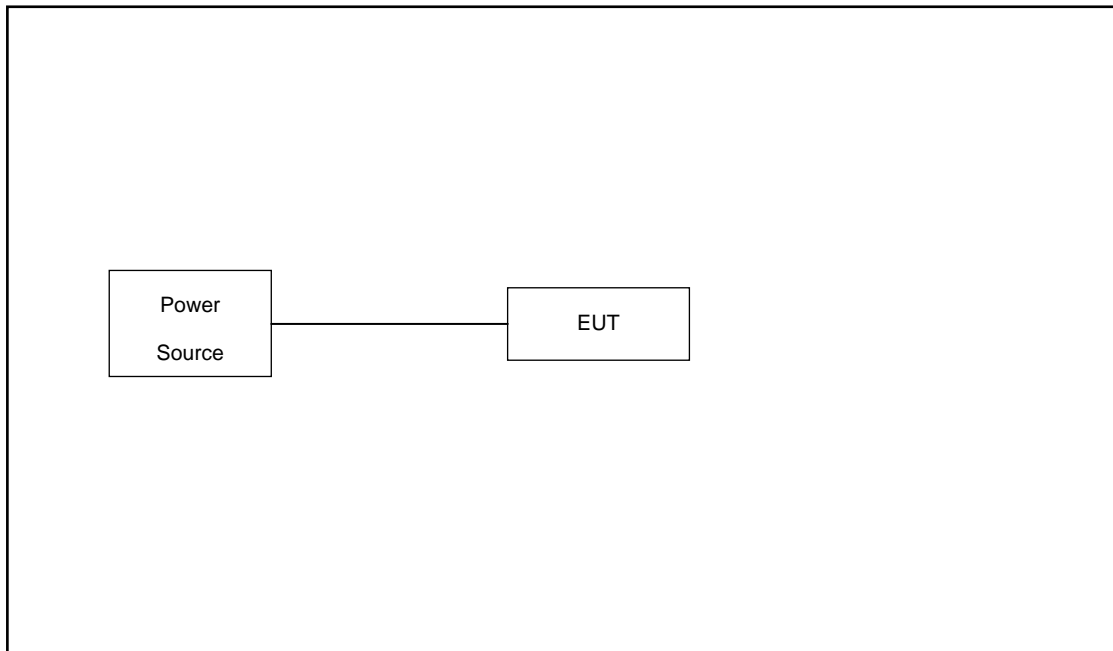

For AC Conducted Emission:

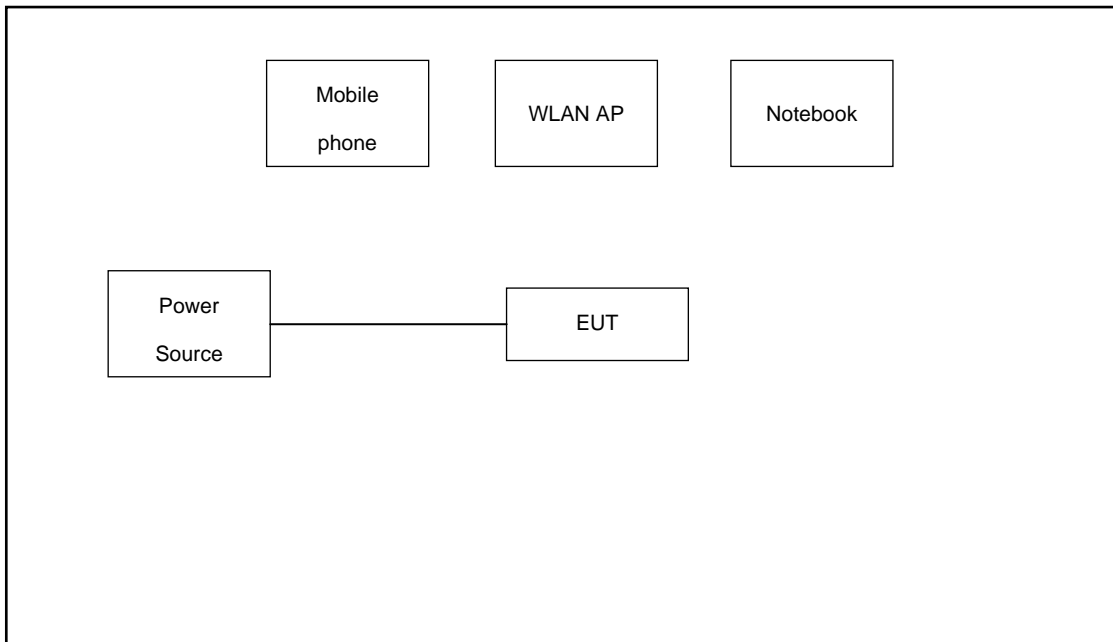

2.4 Support Unit used in test configuration and system

Item	Equipment	Trade Name	Model Name	FCC ID	Data Cable	Power Cord
1.	WLAN AP	D-link	DIR-655	KA21R655B1	N/A	Unshielded, 1.8m
2.	Notebook	Lenovo	G480	QDS-BRCM1050I	N/A	AC I/P: Unshielded, 1.8 m DC O/P: Shielded, 1.8 m
3.	Mobile Phone	MOTO	XT1952-1	N/A	N/A	N/A

2.5 EUT Operation Test Setup

For WLAN RF test items, an engineering test program was provided and enabled to make EUT continuous transmit/receive.

For AC power line conducted emissions, the EUT was set to connect with the WLAN AP under large package sizes transmission.

2.6 Measurement Results Explanation Example

For all conducted test items:

The offset level is set in the spectrum analyzer to compensate the RF cable loss and attenuator factor between EUT conducted output port and spectrum analyzer. With the offset compensation, the spectrum analyzer reading level is exactly the EUT RF output level.

Example :

The spectrum analyzer offset is derived from RF cable loss and attenuator factor.

Offset = RF cable loss + attenuator factor.

Following shows an offset computation example with cable loss 7.3 dB and 10dB attenuator.

$$\begin{aligned}
 \text{Offset(dB)} &= \text{RF cable loss(dB)} + \text{attenuator factor(dB)}. \\
 &= 7.3 + 10 = 17.3 \text{ (dB)}
 \end{aligned}$$

3 Test Result

3.1 26dB & 99% Occupied Bandwidth Measurement

3.1.1 Description of 26dB & 99% Occupied Bandwidth

This section is for reporting purpose only.

There is no restriction limits for bandwidth.

For Straddle Channel, According to KDB 789033 D02 General UNII Test Procedures New Rules v02r01, If the power and PSD of the devices are uniform and comply with the lower limits specified for the U-NII-2 bands, a single measurement over the entire emission bandwidth can be performed to show compliance.

3.1.2 Measuring Instruments

The measuring equipment is listed in the section 4 of this test report.

3.1.3 Test Procedures

1. The testing follows FCC KDB 789033 D02 General UNII Test Procedures New Rules v02r01. Section C) Emission bandwidth
2. Set RBW = approximately 1% of the emission bandwidth.
3. Set the VBW > RBW.
4. Detector = Peak.
5. Trace mode = max hold
6. Measure the maximum width of the emission that is 26 dB down from the peak of the emission. Compare this with the RBW setting of the analyzer. Readjust RBW and repeat measurement as needed until the RBW/EBW ratio is approximately 1%.
7. For 99% Bandwidth Measurement, the spectrum analyzer's resolution bandwidth (RBW) is set 1MHz and set the Video bandwidth (VBW) $\geq 3 * RBW$.
8. Measure and record the results in the test report.

3.1.4 Test Setup

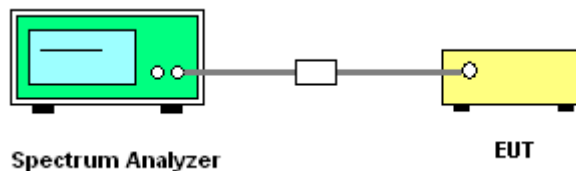

3.1.5 Test Result of 26dB & 99% Occupied Bandwidth

Please refer to Appendix A.

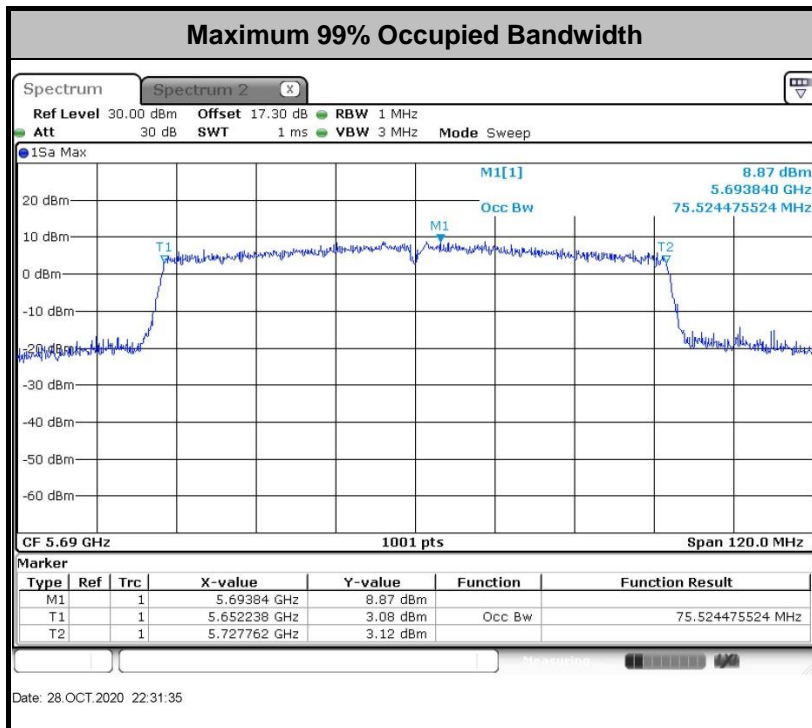
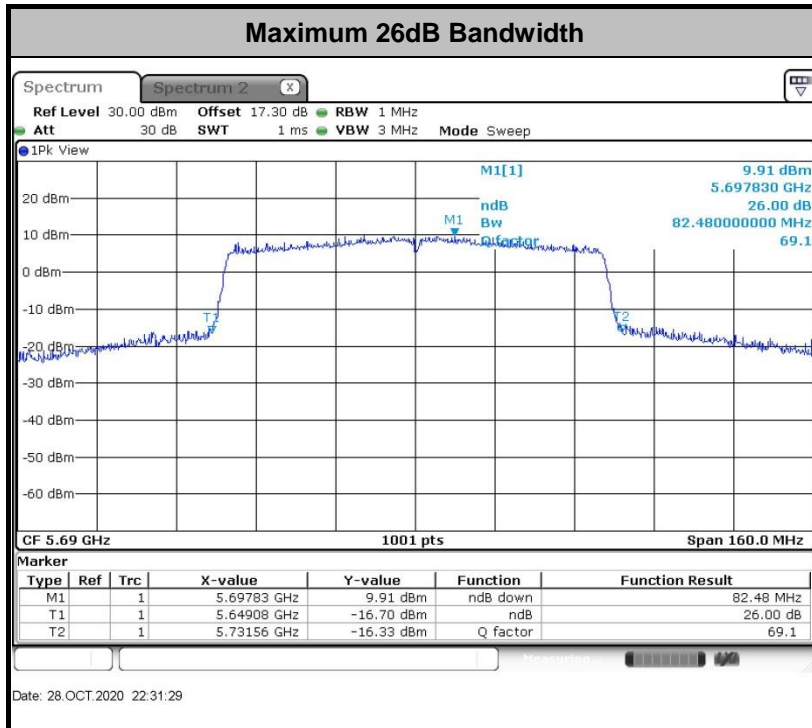

Note: The occupied channel bandwidth is maintained within the band of operation for all of the modulations.



3.2 Maximum Conducted Output Power Measurement

3.2.1 Limit of Maximum Conducted Output Power

<FCC 14-30 CFR 15.407>

For mobile and portable client devices in the 5.15–5.25 GHz band, the maximum conducted output power over the frequency band of operation shall not exceed 250 mW.

For the 5.25–5.725 GHz bands, the maximum conducted output power over the frequency bands of operation shall not exceed the lesser of 250 mW or 11 dBm $10 \log B$, where B is the 26 dB emission bandwidth in megahertz.

For Straddle Channel, According to KDB 789033 D02 General UNII Test Procedures New Rules v02r01, If the power and PSD of the devices are uniform and comply with the lower limits specified for the U-NII-2 bands, a single measurement over the entire emission bandwidth can be performed to show compliance.

If transmitting antennas of directional gain greater than 6 dBi are used, the peak output power shall be reduced by the amount in dB that the directional gain of the antenna exceeds 6 dBi.

Note that U-NII-2 band, devices with a maximum e.i.r.p. greater than 500 mW shall implement TPC in order to have the capability to operate at least 6 dB below the maximum permitted e.i.r.p. of 1 W.

3.2.2 Measuring Instruments

The measuring equipment is listed in the section 4 of this test report.

3.2.3 Test Procedures

The testing follows Method PM of FCC KDB 789033 D02 General UNII Test Procedures New Rules v02r01.

Method PM (Measurement using an RF average power meter):

1. Measurement is performed using a wideband RF power meter.
2. The EUT is configured to transmit continuously with a consistent duty cycle at its maximum power control level.
3. Measure the average power of the transmitter, and the average power is corrected with duty factor, $10 \log(1/x)$, where x is the duty cycle.

For Straddle Channel, According to KDB 789033 D02 General UNII Test Procedures New Rules v02r01, If the power and PSD of the devices are uniform and comply with the lower limits specified for the U-NII-2 bands, a single measurement over the entire emission bandwidth can be performed to show compliance.

3.2.4 Test Setup

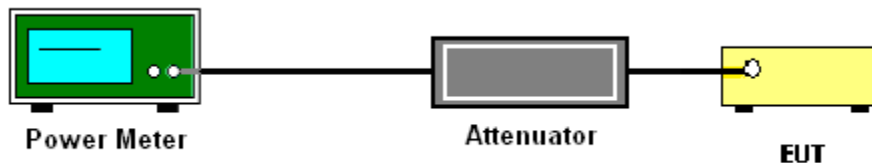

3.2.5 Test Result of Maximum Conducted Output Power

Please refer to Appendix A.



3.3 Power Spectral Density Measurement

3.3.1 Limit of Power Spectral Density

<FCC 14-30 CFR 15.407>

For mobile and portable client devices in the 5.15–5.25 GHz band, the maximum power spectral density shall not exceed 11dBm in any 1 megahertz band.

For the 5.25–5.725 GHz bands, the maximum power spectral density shall not exceed 11 dBm in any 1 megahertz band.

For Straddle Channel, According to KDB 789033 D02 General UNII Test Procedures New Rules v02r01, If the power and PSD of the devices are uniform and comply with the lower limits specified for the U-NII-2 bands, a single measurement over the entire emission bandwidth can be performed to show compliance.

If transmitting antennas of directional gain greater than 6 dBi are used, the peak output power shall be reduced by the amount in dB that the directional gain of the antenna exceeds 6 dBi.

3.3.2 Measuring Instruments

The measuring equipment is listed in the section 4 of this test report.

3.3.3 Test Procedures

The testing follows FCC KDB 789033 D02 General UNII Test Procedures New Rules v02r01.
Section F) Maximum power spectral density.

Method SA-2

(trace averaging across on and off times of the EUT transmissions, followed by duty cycle correction).

- Measure the duty cycle.
 - Set span to encompass the entire emission bandwidth (EBW) of the signal.
 - Set RBW = 1 MHz.
 - Set VBW \geq 3 MHz.
 - Number of points in sweep \geq 2 Span / RBW.
 - Sweep time = auto.
 - Detector = RMS
 - Trace average at least 100 traces in power averaging mode.
 - Add $10 \log(1/x)$, where x is the duty cycle, to the measured power in order to compute the average power during the actual transmission times. For example, add $10 \log(1/0.25) = 6$ dB if the duty cycle is 25 percent.
1. The RF output of EUT was connected to the spectrum analyzer by a low loss cable.
 2. Each plot has already offset with cable loss, and attenuator loss. Measure the PPSD and record it.
 3. For MIMO mode, calculation method follows FCC KDB 662911 D01 Multiple Transmitter Output v02r01.

Method (a): Measure and sum the spectra across the outputs.

The total final Power Spectral Density is from a device with 2 transmitter outputs. The spectrum measurements of the individual outputs are all performed with the same span and number of points, the spectrum value in the first spectral bin of output 1 is summed with that in the first spectral bin of output 2 to obtain the value for the first frequency bin of the summed spectrum.

3.3.4 Test Setup

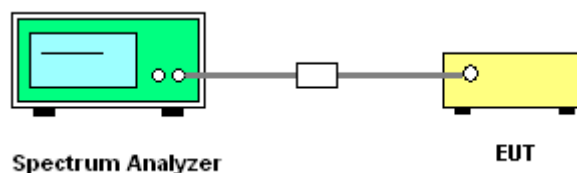



3.3.5 Test Result of Power Spectral Density

Please refer to Appendix A.

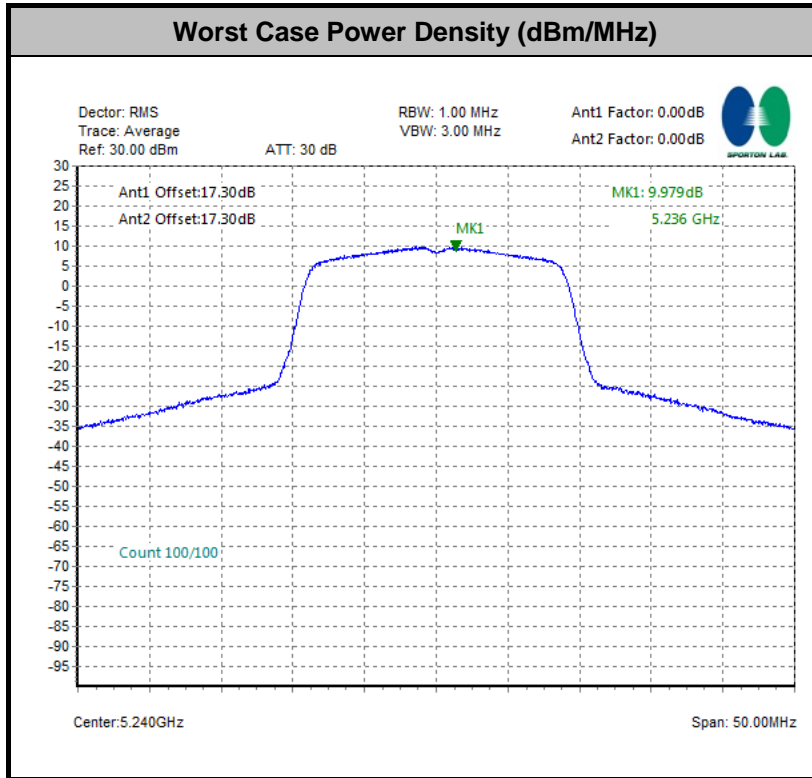



3.4 Unwanted Emissions Measurement

This section is to measure unwanted emissions through radiated measurement for band edge spurious emissions and out of band emissions measurement.

3.4.1 Limit of Unwanted Emissions

- (1) For transmitters operating in the 5150-5250 MHz band: all emissions outside of the 5150-5350 MHz band shall not exceed an EIRP of -27dBm/MHz.

For transmitters operating in the 5250-5350 MHz band: all emissions outside of the 5150-5350 MHz band shall not exceed an EIRP of -27 dBm/MHz. Devices operating in the 5250-5350 MHz band that generate emissions in the 5150-5250 MHz band must meet all applicable technical requirements for operation in the 5150-5250 MHz band (including indoor use) or alternatively meet an out-of-band emission EIRP limit of -27 dBm/MHz in the 5150-5250 MHz band.

For transmitters operating in the 5470-5600 MHz and 5650-5725MHz band: all emissions outside of the 5470-5600 MHz and 5650-5725MHz band shall not exceed an EIRP of -27 dBm/MHz.

- (2) Unwanted spurious emissions fallen in restricted bands shall comply with the general field strength limits as below table,

Frequency (MHz)	Field Strength (microvolts/meter)	Measurement Distance (meters)
0.009 – 0.490	2400/F(kHz)	300
0.490 – 1.705	24000/F(kHz)	30
1.705 – 30.0	30	30
30 – 88	100	3
88 – 216	150	3
216 - 960	200	3
Above 960	500	3



EIRP (dBm)	Field Strength at 3m (dBμV/m)
- 27	68.3

Note: The following formula is used to convert the EIRP to field strength.

$$EIRP = E_{Meas} + 20\log (d_{Meas}) - 104.7$$

where

EIRP is the equivalent isotropically radiated power, in dBm

E_{Meas} is the field strength of the emission at the measurement distance, in dBμV/m

d_{Meas} is the measurement distance, in m

3.4.2 Measuring Instruments

The measuring equipment is listed in the section 4 of this test report.



3.4.3 Test Procedures

1. The testing follows FCC KDB 789033 D02 General UNII Test Procedures New Rules v02r01. Section G) Unwanted emissions measurement.
 - (1) Procedure for Unwanted Emissions Measurements Below 1000MHz
 - RBW = 120 kHz
 - VBW = 300 kHz
 - Detector = Peak
 - Trace mode = max hold
 - (2) Procedure for Peak Unwanted Emissions Measurements Above 1000 MHz
 - RBW = 1 MHz
 - VBW \geq 3 MHz
 - Detector = Peak
 - Sweep time = auto
 - Trace mode = max hold
 - (3) Procedures for Average Unwanted Emissions Measurements Above 1000MHz
 - RBW = 1 MHz
 - VBW = 10 Hz, when duty cycle is no less than 98 percent.
 - VBW \geq 1/T, when duty cycle is less than 98 percent where T is the minimum transmission duration over which the transmitter is on and is transmitting at its maximum power control level for the tested mode of operation.
2. The EUT was placed on a turntable with 0.8 meter for frequency below 1GHz and 1.5 meter for frequency above 1GHz respectively above ground.
3. The EUT was set 3 meters from the interference receiving antenna which was mounted on the top of a variable height antenna tower.
4. The antenna is a broadband antenna and its height is adjusted between one meter and four meters above ground to find the maximum value of the field strength for both horizontal polarization and vertical polarization of the antenna.
5. For each suspected emission, the EUT was arranged to its worst case and then adjust the antenna tower (from 1 m to 4 m) and turntable (from 0 degree to 360 degrees) to find the maximum reading.
6. For testing below 1GHz, if the emission level of the EUT in peak mode was 3 dB lower than the limit specified, then peak values of EUT will be reported, otherwise, the emissions will be repeated one by one using the CISPR quasi-peak method and reported.
7. For testing above 1GHz, the emission level of the EUT in peak mode was 20dB lower than peak limit (that means the emission level in average mode also complies with the limit in average mode), then peak values of EUT will be reported, otherwise, the emissions will be measured in average mode again and reported.

3.4.4 Test Setup

For radiated emissions below 30MHz

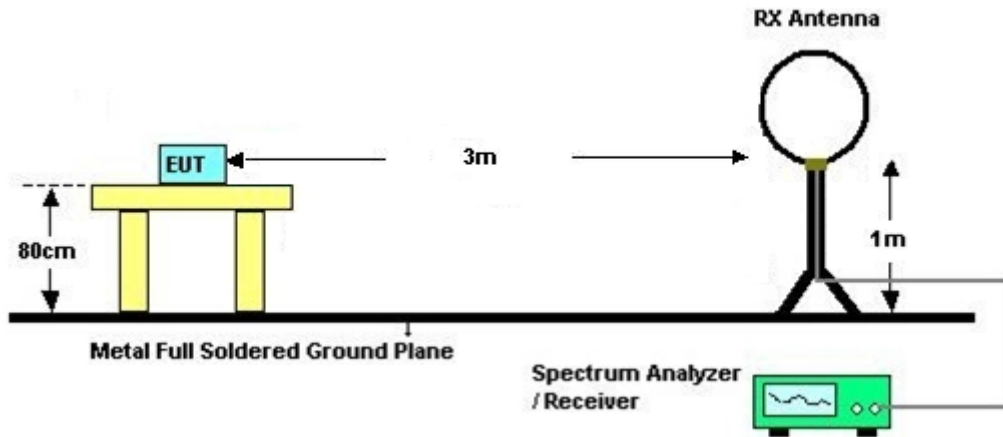

For radiated emissions from 30MHz to 1GHz

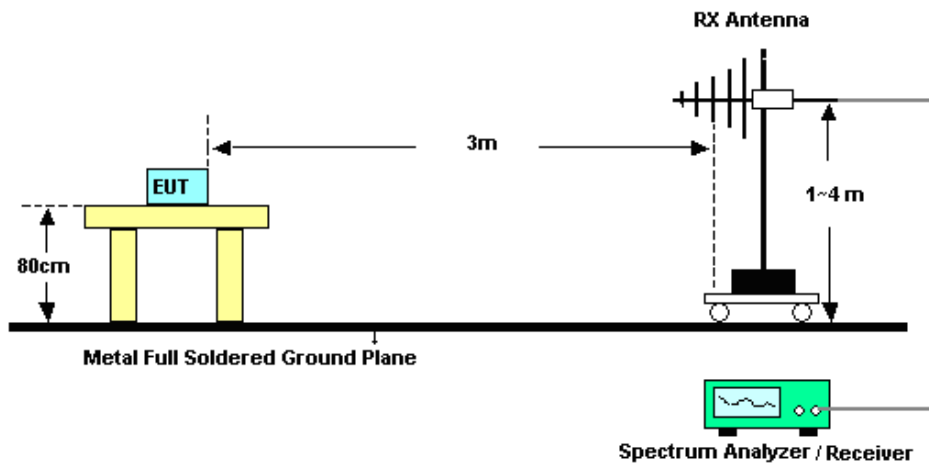

For radiated emissions above 1GHz

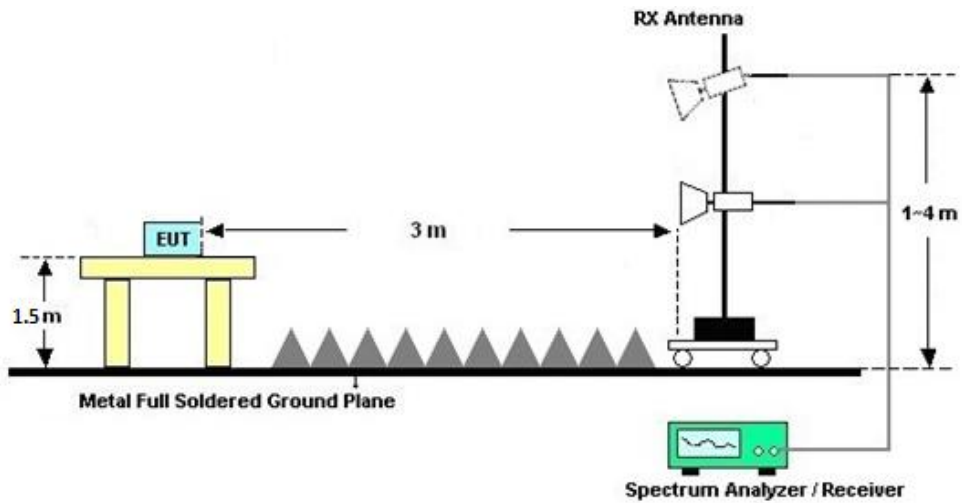

3.4.5 Test Results of Radiated Spurious Emissions (9 kHz ~ 30 MHz)

The low frequency, which started from 9 kHz to 30MHz, was pre-scanned and the result which was 20dB lower than the limit line was not reported.

There is a comparison data of both open-field test site and semi-Anechoic chamber, and the result came out very similar.

3.4.6 Test Result of Radiated Spurious at Band Edges

Please refer to Appendix C.

3.4.7 Duty Cycle

Please refer to Appendix D.

3.4.8 Test Result of Radiated Spurious Emissions (30MHz ~ 10th Harmonic or 40GHz, whichever is lower)

Please refer to Appendix C.



3.5 AC Conducted Emission Measurement

3.5.1 Limit of AC Conducted Emission

For equipment that is designed to be connected to the public utility (AC) power line, the radio frequency voltage that is conducted back onto the AC power line on any frequency or frequencies within the band 150 kHz to 30 MHz shall not exceed the limits in the following table.

Frequency of emission (MHz)	Conducted limit (dBµV)	
	Quasi-peak	Average
0.15-0.5	66 to 56*	56 to 46*
0.5-5	56	46
5-30	60	50

*Decreases with the logarithm of the frequency.

3.5.2 Measuring Instruments

The measuring equipment is listed in the section 4 of this test report.

3.5.3 Test Procedures

1. The EUT was placed 0.4 meter from the conducting wall of the shielding room was kept at least 80 centimeters from any other grounded conducting surface.
2. Connect EUT to the power mains through a line impedance stabilization network (LISN).
3. All the support units are connecting to the other LISN.
4. The LISN provides 50 ohm coupling impedance for the measuring instrument.
5. The FCC states that a 50 ohm, 50 microhenry LISN should be used.
6. Both sides of AC line were checked for maximum conducted interference.
7. The frequency range from 150 kHz to 30 MHz was searched.
8. Set the test-receiver system to Peak Detect Function and specified bandwidth with Maximum Hold Mode.

3.5.4 Test Setup

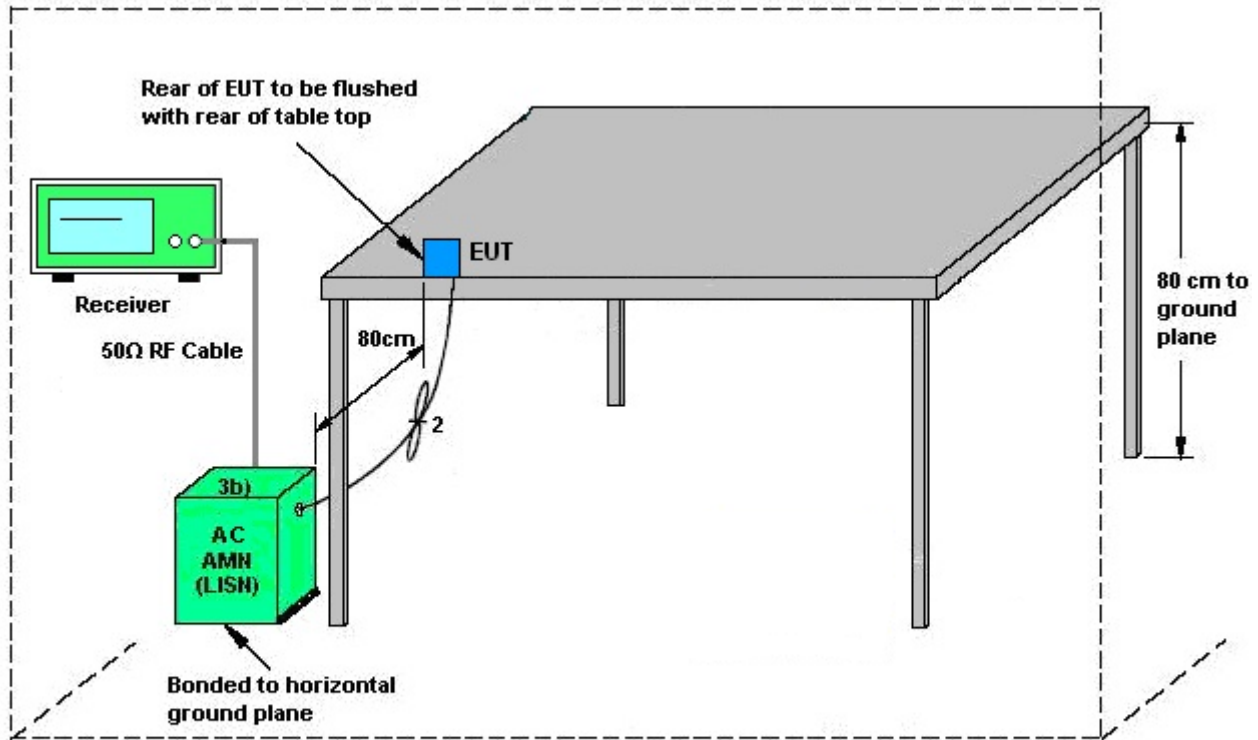

AMN = Artificial mains network (LISH)
AE = Associated equipment
EUT = Equipment under test
ISN = Impedance stabilization network

3.5.5 Test Result of AC Conducted Emission

Please refer to Appendix B.



3.6 Automatically Discontinue Transmission

3.6.1 Limit of Automatically Discontinue Transmission

The device shall automatically discontinue transmission in case of either absence of information to transmit or operational failure. These provisions are not intended to preclude the transmission of control or signaling information or the use of repetitive codes used by certain digital technologies to complete frame or burst intervals. Applicants shall include in their application for equipment authorization to describe how this requirement is met.

3.6.2 Measuring Instruments

The measuring equipment is listed in the section 4 of this test report.

3.6.3 Test Result of Automatically Discontinue Transmission

While the EUT is not transmitting any information, the EUT can automatically discontinue transmission and become standby mode for power saving. The EUT can detect the controlling signal of ACK message transmitting from remote device and verify whether it shall resend or discontinue transmission.



3.7 Antenna Requirements

3.7.1 Standard Applicable

If transmitting antenna directional gain is greater than 6 dBi, both the peak transmit power and the peak power spectral density shall be reduced by the amount in dB that the directional gain of the antenna exceeds 6 dBi.

3.7.2 Antenna Anti-Replacement Construction

An embedded-in antenna design is used.

3.7.3 Antenna Gain

	Ant. 1 (dBi)	Ant. 2 (dBi)	DG for Power (dBi)	DG for PSD (dBi)	Power Limit Reduction (dB)	PSD Limit Reduction (dB)
Band I	4.22	4.15	4.22	4.22	0.00	0.00
Band II	4.79	4.24	4.79	4.79	0.00	0.00
Band III	4.36	4.98	4.98	4.98	0.00	0.00



4 List of Measuring Equipment

Instrument	Manufacturer	Model No.	Serial No.	Characteristics	Calibration Date	Test Date	Due Date	Remark
Spectrum Analyzer	R&S	FSV40	101040	10Hz~40GHz	Nov. 02, 2019	Oct. 26, 2020~ Oct. 28, 2020	Nov. 01, 2020	Conducted (TH01-KS)
Pulse Power Sensor	Anritsu	MA2411B	0917070	300MHz~40GHz	Jan. 15, 2020	Oct. 26, 2020~ Oct. 28, 2020	Jan. 14, 2021	Conducted (TH01-KS)
Power Meter	Anritsu	ML2495A	1005002	50MHz Bandwidth	Jan. 08, 2020	Oct. 26, 2020~ Oct. 28, 2020	Jan. 07, 2021	Conducted (TH01-KS)
EMI Test Receiver	Keysight	N9038A	MY564000 04	3Hz~8.5GHz;M ax 30dBm	Oct. 17, 2020	Nov. 02, 2020	Oct. 16, 2021	Radiation (03CH06-KS)
EXA Spectrum Analyzer	Keysight	N9010A	MY551502 08	10Hz~44GHz	Apr. 14, 2020	Nov. 02, 2020	Apr. 13, 2021	Radiation (03CH06-KS)
Loop Antenna	R&S	HFH2-Z2	100321	9kHz~30MHz	Nov. 10, 2019	Nov. 02, 2020	Nov. 09, 2020	Radiation (03CH06-KS)
Bilog Antenna	TeseQ	CBL6111D	49921	30MHz~1GHz	May 29, 2020	Nov. 02, 2020	May 28, 2021	Radiation (03CH06-KS)
Double Ridge Horn Antenna	ETS-Lindgren	3117	00218652	1GHz~18GHz	Apr. 27, 2020	Nov. 02, 2020	Apr. 26, 2021	Radiation (03CH06-KS)
SHF-EHF Horn	Com-power	AH-840	101115	18GHz~40GHz	Nov. 10, 2019	Nov. 02, 2020	Nov. 09, 2020	Radiation (03CH06-KS)
Amplifier	SONOMA	310N	187289	9KHz ~1GHZ	Apr. 14, 2020	Nov. 02, 2020	Apr. 13, 2021	Radiation (03CH06-KS)
Amplifier	MITEQ	EM18G40GG A	060728	18~40GHz	Jan. 08, 2020	Nov. 02, 2020	Jan. 07, 2021	Radiation (03CH06-KS)
high gain Amplifier	MITEQ	AMF-7D-0010 1800-30-10P	2025788	1Ghz-18Ghz	Jan. 02, 2020	Nov. 02, 2020	Jan. 01, 2021	Radiation (03CH06-KS)
Amplifier	Keysight	83017A	MY532702 03	500MHz~26.5G Hz	Apr. 15, 2020	Nov. 02, 2020	Apr. 14, 2021	Radiation (03CH06-KS)
AC Power Source	Chroma	61601	F1040900 04	N/A	NCR	Nov. 02, 2020	NCR	Radiation (03CH06-KS)
Turn Table	ChamPro	EM 1000-T	060762-T	0~360 degree	NCR	Nov. 02, 2020	NCR	Radiation (03CH06-KS)
Antenna Mast	ChamPro	EM 1000-A	060762-A	1 m~4 m	NCR	Nov. 02, 2020	NCR	Radiation (03CH06-KS)
EMI Receiver	R&S	ESCI7	100768	9kHz~7GHz;	Apr. 14, 2020	Sep. 23, 2020	Apr. 13, 2021	Conduction (CO01-KS)
AC LISN (for auxiliary equipment)	MessTec	AN3016	060103	9kHz~30MHz	Oct. 18, 2019	Sep. 23, 2020	Oct. 17, 2020	Conduction (CO01-KS)
AC LISN	MessTec	AN3016	060105	9kHz~30MHz	Oct. 28, 2019	Sep. 23, 2020	Oct. 27, 2020	Conduction (CO01-KS)
AC Power Source	Chroma	61602	ABP00000 0811	AC 0V~300V, 45Hz~1000Hz	Oct. 18, 2019	Sep. 23, 2020	Oct. 17, 2020	Conduction (CO01-KS)

NCR: No Calibration Required



5 Uncertainty of Evaluation

The measurement uncertainties shown below were calculated in accordance with the requirements of ANSI 63.10-2013. All the measurement uncertainty value were shown with a coverage K=2 to indicate 95% level of confidence. The measurement data show herein meets or exceeds the CISPR measurement uncertainty values specified in CISPR 16-4-2 and can be compared directly to specified limit to determine compliance.

Uncertainty of Conducted Emission Measurement (150kHz ~ 30MHz)

Measuring Uncertainty for a Level of Confidence of 95% (U = 2Uc(y))	2.9dB
---	-------

Uncertainty of Radiated Emission Measurement (30 MHz ~ 1000 MHz)

Measuring Uncertainty for a Level of Confidence of 95% (U = 2Uc(y))	5.0dB
---	-------

Uncertainty of Radiated Emission Measurement (1000 MHz ~ 18000 MHz)

Measuring Uncertainty for a Level of Confidence of 95% (U = 2Uc(y))	5.0dB
---	-------

Uncertainty of Radiated Emission Measurement (18000 MHz ~ 40000 MHz)

Measuring Uncertainty for a Level of Confidence of 95% (U = 2Uc(y))	5.0dB
---	-------



Appendix A. Conducted Test Results

Test Engineer:	Aly Cao	Temperature:	21~25	°C
Test Date:	2020/10/26~2020/10/28	Relative Humidity:	51~54	%

TEST RESULTS DATA
26dB and 99% OBW

Band I													
Mod.	Data Rate	NTX	CH.	Freq. (MHz)	99% Bandwidth (MHz)		26 dB Bandwidth (MHz)		IC 99% Bandwidth Power Limit (dBm)		IC 99% Bandwidth EIRP Limit (dBm)		Note
					Ant 1	Ant 2	Ant 1	Ant 2	Ant 1	Ant 2	Ant 1	Ant 2	
11a	6Mbps	2	36	5180	17.18	17.08	20.83	20.63	-	-	22.33	-	
11a	6Mbps	2	44	5220	17.38	17.33	20.98	20.88	-	-	22.39	-	
11a	6Mbps	2	48	5240	17.33	17.33	21.03	21.08	-	-	22.39	-	
VHT20	MCS0	2	36	5180	18.18	18.23	21.08	21.23	-	-	22.60	-	
VHT20	MCS0	2	44	5220	18.13	18.18	21.23	21.18	-	-	22.58	-	
VHT20	MCS0	2	48	5240	18.18	18.23	21.13	21.28	-	-	22.60	-	
VHT40	MCS0	2	38	5190	36.16	36.26	41.36	41.36	-	-	23.01	-	
VHT40	MCS0	2	46	5230	36.36	36.26	41.18	41.63	-	-	23.01	-	
VHT80	MCS0	2	42	5210	75.40	75.52	80.88	80.56	-	-	23.01	-	

TEST RESULTS DATA
Average Power Table

FCC Band I														
Mod.	Data Rate	NTX	CH.	Freq. (MHz)	Duty Factor (dB)		Average Conducted Power (dBm)			FCC Conducted Power Limit (dBm)		DG (dBi)		Pass/Fail
					Ant 1	Ant 2	Ant 1	Ant 2	SUM	Ant 1	Ant 2	Ant 1	Ant 2	
11a	6Mbps	2	36	5180	0.00	0.00	17.51	17.58	20.56	24.00	24.00	4.22	4.22	Pass
11a	6Mbps	2	44	5220	0.00	0.00	17.42	17.53	20.49	24.00	24.00	4.22	4.22	Pass
11a	6Mbps	2	48	5240	0.00	0.00	17.56	17.38	20.48	24.00	24.00	4.22	4.22	Pass
VHT20	MCS0	2	36	5180	0.00	0.00	17.66	17.51	20.60	24.00	24.00	4.22	4.22	Pass
VHT20	MCS0	2	44	5220	0.00	0.00	17.74	17.56	20.66	24.00	24.00	4.22	4.22	Pass
VHT20	MCS0	2	48	5240	0.00	0.00	17.70	17.65	20.69	24.00	24.00	4.22	4.22	Pass
VHT40	MCS0	2	38	5190	0.00	0.00	15.71	15.92	18.83	24.00	24.00	4.22	4.22	Pass
VHT40	MCS0	2	46	5230	0.00	0.00	18.79	18.60	21.71	24.00	24.00	4.22	4.22	Pass
VHT80	MCS0	2	42	5210	0.00	0.00	12.78	12.68	15.74	24.00	24.00	4.22	4.22	Pass

TEST RESULTS DATA
Power Spectral Density

FCC Band I														
Mod.	Data Rate	NTX	CH.	Freq. (MHz)	Duty Factor (dB)		Average Power Density (dBm/MHz)			Average PSD Limit (dBm/MHz)		DG (dBi)		Pass /Fail
					Ant 1	Ant 2	Ant 1	Ant 2	SUM	Ant 1	Ant 2	Ant 1	Ant 2	
11a	6Mbps	2	36	5180	0.00	0.00			9.88	11.00			4.22	Pass
11a	6Mbps	2	44	5220	0.00	0.00			9.74	11.00			4.22	Pass
11a	6Mbps	2	48	5240	0.00	0.00			9.83	11.00			4.22	Pass
VHT20	MCS0	2	36	5180	0.00	0.00			9.92	11.00			4.22	Pass
VHT20	MCS0	2	44	5220	0.00	0.00			9.96	11.00			4.22	Pass
VHT20	MCS0	2	48	5240	0.00	0.00			9.98	11.00			4.22	Pass
VHT40	MCS0	2	38	5190	0.00	0.00			5.43	11.00			4.22	Pass
VHT40	MCS0	2	46	5230	0.00	0.00			8.33	11.00			4.22	Pass
VHT80	MCS0	2	42	5210	0.00	0.00			-0.36	11.00			4.22	Pass

TEST RESULTS DATA
26dB and 99% OBW

Band II															
Mod.	Data Rate	NTX	CH.	Freq. (MHz)	99% Bandwidth (MHz)		26 dB Bandwidth (MHz)		IC 99% Bandwidth Power Limit (dBm)		IC 99% Bandwidth EIRP Limit (dBm)		FCC 26dB Bandwidth Power Limit (dBm)		Note
					Ant 1	Ant 2	Ant 1	Ant 2	Ant 1	Ant 2	Ant 1	Ant 2	Ant 1	Ant 2	
11a	6Mbps	2	52	5260	17.28	17.18	20.88	20.93	23.35	23.35	29.35	29.35	23.98		
11a	6Mbps	2	60	5300	17.33	17.23	21.03	21.08	23.36	23.36	29.36	29.36	23.98		
11a	6Mbps	2	64	5320	17.33	17.38	21.18	21.03	23.39	23.39	29.39	29.39	23.98		
VHT20	MCS0	2	52	5260	18.18	18.13	21.33	21.23	23.58	23.58	29.58	29.58	23.98		
VHT20	MCS0	2	60	5300	18.18	18.23	21.13	21.23	23.60	23.60	29.60	29.60	23.98		
VHT20	MCS0	2	64	5320	18.23	18.28	21.23	21.28	23.61	23.61	29.61	29.61	23.98		
VHT40	MCS0	2	54	5270	36.36	36.36	41.54	41.54	23.98	23.98	30.00	30.00	23.98		
VHT40	MCS0	2	62	5310	36.16	36.16	41.09	41.09	23.98	23.98	30.00	30.00	23.98		
VHT80	MCS0	2	58	5290	75.40	75.28	80.88	80.72	23.98	23.98	30.00	30.00	23.98		

TEST RESULTS DATA
Average Power Table

FCC Band II															
Mod.	Data Rate	NTX	CH.	Freq. (MHz)	Duty Factor (dB)		Average Conducted Power (dBm)			FCC Conducted Power Limit (dBm)		DG (dBi)		EIRP Power Limit (dBm)	Pass/Fail
					Ant 1	Ant 2	Ant 1	Ant 2	SUM	Ant 1	Ant 2	Ant 1	Ant 2		
11a	6Mbps	2	52	5260	0.00	0.00	17.44	17.54	20.50	23.98		4.79	26.99	Pass	
11a	6Mbps	2	60	5300	0.00	0.00	17.46	17.51	20.50	23.98		4.79	26.99	Pass	
11a	6Mbps	2	64	5320	0.00	0.00	17.51	17.52	20.53	23.98		4.79	26.99	Pass	
VHT20	MCS0	2	52	5260	0.00	0.00	17.74	17.73	20.75	23.98		4.79	26.99	Pass	
VHT20	MCS0	2	60	5300	0.00	0.00	17.76	17.71	20.75	23.98		4.79	26.99	Pass	
VHT20	MCS0	2	64	5320	0.00	0.00	17.15	16.91	20.04	23.98		4.79	26.99	Pass	
VHT40	MCS0	2	54	5270	0.00	0.00	18.61	18.52	21.58	23.98		4.79	26.99	Pass	
VHT40	MCS0	2	62	5310	0.00	0.00	15.37	15.42	18.41	23.98		4.79	26.99	Pass	
VHT80	MCS0	2	58	5290	0.00	0.00	12.58	12.44	15.52	23.98		4.79	26.99	Pass	

TEST RESULTS DATA
Power Spectral Density

Band II														
Mod.	Data Rate	NTX	CH.	Freq. (MHz)	Duty Factor (dB)		Average Power Density (dBm/MHz)			Average PSD Limit (dBm/MHz)		DG (dBi)		Pass /Fail
					Ant 1	Ant 2	Ant 1	Ant 2	SUM	Ant 1	Ant 2	Ant 1	Ant 2	
11a	6Mbps	2	52	5260	0.00	0.00			9.77	11.00			4.79	Pass
11a	6Mbps	2	60	5300	0.00	0.00			9.79	11.00			4.79	Pass
11a	6Mbps	2	64	5320	0.00	0.00			9.69	11.00			4.79	Pass
VHT20	MCS0	2	52	5260	0.00	0.00			9.76	11.00			4.79	Pass
VHT20	MCS0	2	60	5300	0.00	0.00			9.68	11.00			4.79	Pass
VHT20	MCS0	2	64	5320	0.00	0.00			9.33	11.00			4.79	Pass
VHT40	MCS0	2	54	5270	0.00	0.00			8.24	11.00			4.79	Pass
VHT40	MCS0	2	62	5310	0.00	0.00			5.15	11.00			4.79	Pass
VHT80	MCS0	2	58	5290	0.00	0.00			-0.47	11.00			4.79	Pass

TEST RESULTS DATA
26dB and 99% OBW

Band III															
Mod.	Data Rate	NTX	CH.	Freq. (MHz)	99% Bandwidth (MHz)		26 dB Bandwidth (MHz)		IC 99% Bandwidth Power Limit (dBm)		IC 99% Bandwidth EIRP Limit (dBm)		FCC 26dB Bandwidth Power Limit (dBm)		Note
					Ant 1	Ant 2	Ant 1	Ant 2	Ant 1	Ant 2	Ant 1	Ant 2	Ant 1	Ant 2	
11a	6Mbps	2	100	5500	17.43	17.33	21.03	21.08	23.39		29.39		23.98		
11a	6Mbps	2	116	5580	17.38	17.28	21.23	21.23	23.38		29.38		23.98		
11a	6Mbps	2	140	5700	17.28	17.28	20.98	20.88	23.38		29.38		23.98		
11a	6Mbps	2	144	5720	17.58	17.48	21.28	21.28	23.43		29.43		23.98		
VHT20	MCS0	2	100	5500	18.13	18.08	21.13	21.13	23.57		29.57		23.98		
VHT20	MCS0	2	116	5580	18.18	18.34	21.23	21.23	23.60		29.60		23.98		
VHT20	MCS0	2	140	5700	18.08	18.08	21.28	21.23	23.57		29.57		23.98		
VHT20	MCS0	2	144	5720	18.23	18.28	21.58	21.43	23.61		29.61		23.98		
VHT40	MCS0	2	102	5510	36.26	36.16	41.36	41.36	23.98		30.00		23.98		
VHT40	MCS0	2	110	5550	36.36	36.36	41.99	41.72	23.98		30.00		23.98		
VHT40	MCS0	2	134	5670	36.16	36.36	41.81	41.36	23.98		30.00		23.98		
VHT40	MCS0	2	142	5710	36.46	36.46	41.99	41.90	23.98		30.00		23.98		
VHT80	MCS0	2	106	5530	75.28	75.28	80.40	80.40	23.98		30.00		23.98		
VHT80	MCS0	2	122	5610	75.28	75.41	80.56	80.88	23.98		30.00		23.98		
VHT80	MCS0	2	138	5690	75.52	75.52	81.68	82.48	23.98		30.00		23.98		

TEST RESULTS DATA
Average Power Table

FCC Band III															
Mod.	Data Rate	NTX	CH.	Freq. (MHz)	Duty Factor (dB)		Average Conducted Power (dBm)			FCC Conducted Power Limit (dBm)		DG (dBi)		EIRP Power Limit (dBm)	Pass/Fail
					Ant 1	Ant 2	Ant 1	Ant 2	SUM	Ant 1	Ant 2	Ant 1	Ant 2		
11a	6Mbps	2	100	5500	0.00	0.00	17.50	17.49	20.51	23.98		4.98		26.99	Pass
11a	6Mbps	2	116	5580	0.00	0.00	17.55	17.50	20.54	23.98		4.98		26.99	Pass
11a	6Mbps	2	140	5700	0.00	0.00	16.07	15.60	18.85	23.98		4.98		26.99	Pass
11a	6Mbps	2	144	5720	0.00	0.00	17.51	20.50	20.46	23.98		4.98		26.99	Pass
VHT20	MCS0	2	100	5500	0.00	0.00	16.88	17.00	19.95	23.98		4.98		26.99	Pass
VHT20	MCS0	2	116	5580	0.00	0.00	17.70	17.49	20.61	23.98		4.98		26.99	Pass
VHT20	MCS0	2	140	5700	0.00	0.00	14.62	13.86	17.27	23.98		4.98		26.99	Pass
VHT20	MCS0	2	144	5720	0.00	0.00	17.98	17.18	20.61	23.98		4.98		26.99	Pass
VHT40	MCS0	2	102	5510	0.00	0.00	16.17	16.02	19.11	23.98		4.98		26.99	Pass
VHT40	MCS0	2	110	5550	0.00	0.00	18.35	18.42	21.40	23.98		4.98		26.99	Pass
VHT40	MCS0	2	134	5670	0.00	0.00	16.70	16.46	19.59	23.98		4.98		26.99	Pass
VHT40	MCS0	2	142	5710	0.00	0.00	18.77	17.92	21.38	23.98		4.98		26.99	Pass
VHT80	MCS0	2	106	5530	0.00	0.00	12.34	12.15	15.26	23.98		4.98		26.99	Pass
VHT80	MCS0	2	122	5610	0.00	0.00	18.50	18.29	21.41	23.98		4.98		26.99	Pass
VHT80	MCS0	2	138	5690	0.00	0.00	18.39	18.22	21.32	23.98		4.98		26.99	Pass

TEST RESULTS DATA
Power Spectral Density

Band III														
Mod.	Data Rate	NTX	CH.	Freq. (MHz)	Duty Factor (dB)		Average Power Density (dBm/MHz)			Average PSD Limit (dBm/MHz)		DG (dBi)		Pass /Fail
					Ant 1	Ant 2	Ant 1	Ant 2	SUM	Ant 1	Ant 2	Ant 1	Ant 2	
11a	6Mbps	2	100	5500	0.00	0.00			9.88	11.00	4.98			Pass
11a	6Mbps	2	116	5580	0.00	0.00			9.80	11.00	4.98			Pass
11a	6Mbps	2	140	5700	0.00	0.00			7.80	11.00	4.98			Pass
11a	6Mbps	2	144	5720	0.00	0.00			9.69	11.00	4.98			Pass
VHT20	MCS0	2	100	5500	0.00	0.00			9.30	11.00	4.98			Pass
VHT20	MCS0	2	116	5580	0.00	0.00			9.57	11.00	4.98			Pass
VHT20	MCS0	2	140	5700	0.00	0.00			6.03	11.00	4.98			Pass
VHT20	MCS0	2	144	5720	0.00	0.00			9.59	11.00	4.98			Pass
VHT40	MCS0	2	102	5510	0.00	0.00			6.03	11.00	4.98			Pass
VHT40	MCS0	2	110	5550	0.00	0.00			7.83	11.00	4.98			Pass
VHT40	MCS0	2	134	5670	0.00	0.00			5.78	11.00	4.98			Pass
VHT40	MCS0	2	142	5710	0.00	0.00			7.06	11.00	4.98			Pass
VHT80	MCS0	2	106	5530	0.00	0.00			-1.12	11.00	4.98			Pass
VHT80	MCS0	2	122	5610	0.00	0.00			4.76	11.00	4.98			Pass
VHT80	chain0	2	138	5690	0.00	0.00			4.83	11.00	4.98			Pass



Appendix B. AC Conducted Emission Test Results

Test Engineer :	Amos Zhang	Temperature :	24.2~25.6°C
		Relative Humidity :	37~39%
Test Voltage :	120Vac / 60Hz	Phase :	Line
Remark :	All emissions not reported here are more than 10 dB below the prescribed limit.		

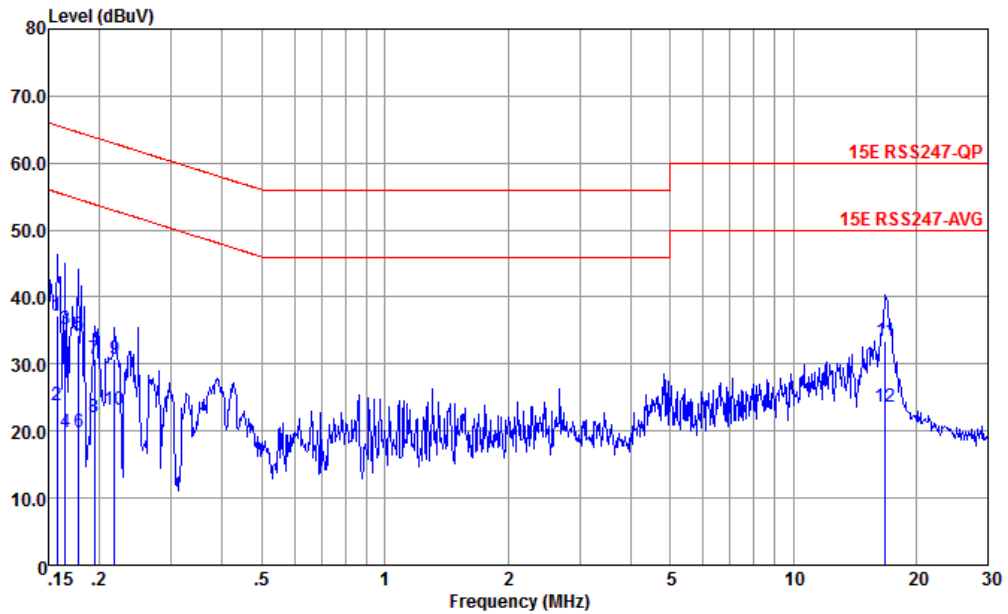

Site : CO01-KS
 Condition : 15E RSS247-QP LISN-L-191028-CN02 LINE

	Freq	Level	Over	Limit	Read	LISN	Cable	Remark
	MHz	dBuV	Limit	Line	Level	Factor	Loss	
			dB	dBuV	dBuV	dB	dB	
1	0.157	37.13	-28.47	65.60	26.60	0.07	10.46	QP
2	0.157	23.83	-31.77	55.60	13.30	0.07	10.46	Average
3	0.165	35.12	-30.09	65.21	24.60	0.08	10.44	QP
4	0.165	19.82	-35.39	55.21	9.30	0.08	10.44	Average
5	0.178	34.29	-30.30	64.59	23.80	0.08	10.41	QP
6	0.178	19.79	-34.80	54.59	9.30	0.08	10.41	Average
7	0.194	30.66	-33.18	63.84	20.20	0.09	10.37	QP
8	0.194	21.96	-31.88	53.84	11.50	0.09	10.37	Average
9	0.217	30.64	-32.28	62.92	20.20	0.09	10.35	QP
10	0.217	23.24	-29.68	52.92	12.80	0.09	10.35	Average
11	16.839	33.43	-26.57	60.00	21.19	1.80	10.44	QP
12 *	16.839	23.73	-26.27	50.00	11.49	1.80	10.44	Average



Test Engineer :	Amos Zhang	Temperature :	24.2~25.6°C
		Relative Humidity :	37~39%
Test Voltage :	120Vac / 60Hz	Phase :	Neutral
Remark :	All emissions not reported here are more than 10 dB below the prescribed limit.		

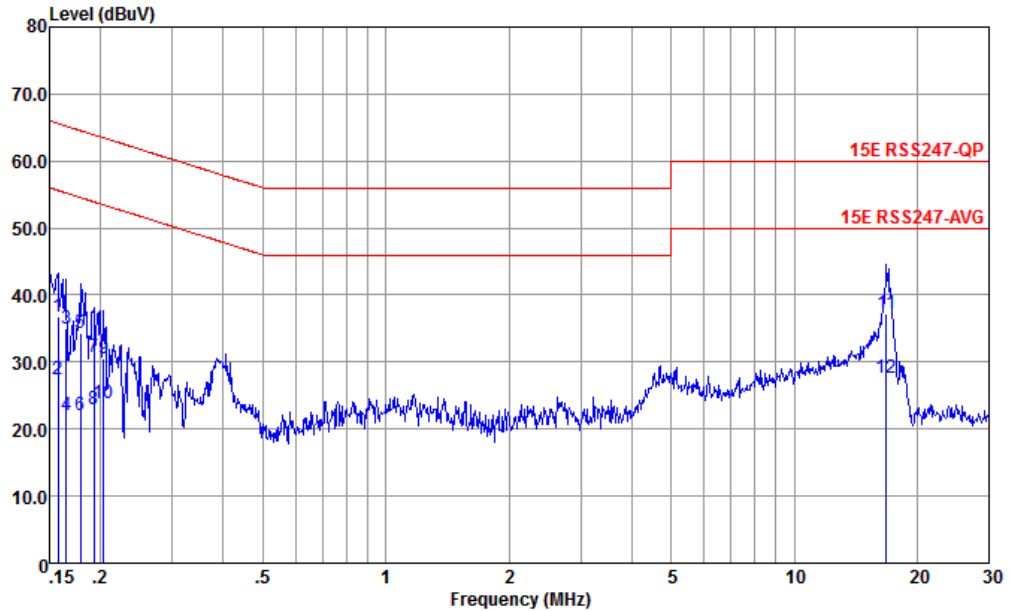

Site : CO01-KS
 Condition : 15E RSS247-QP LISN-N-191028-CN02 NEUTRAL

	Freq	Level	Over	Limit	Read	LISN	Cable	Remark
	MHz	dBuV	Limit	Line	Level	Factor	Loss	
			dB	dBuV	dBuV	dB	dB	
1	0.157	36.81	-28.79	65.60	26.20	0.15	10.46	QP
2	0.157	27.51	-28.09	55.60	16.90	0.15	10.46	Average
3	0.165	35.10	-30.11	65.21	24.50	0.16	10.44	QP
4	0.165	22.10	-33.11	55.21	11.50	0.16	10.44	Average
5	0.179	34.37	-30.18	64.55	23.80	0.16	10.41	QP
6	0.179	22.07	-32.48	54.55	11.50	0.16	10.41	Average
7	0.192	30.64	-33.29	63.93	20.09	0.17	10.38	QP
8	0.192	23.04	-30.89	53.93	12.49	0.17	10.38	Average
9	0.204	30.63	-32.82	63.45	20.10	0.17	10.36	QP
10	0.204	23.83	-29.62	53.45	13.30	0.17	10.36	Average
11	16.839	37.31	-22.69	60.00	24.59	2.28	10.44	QP
12 *	16.839	27.61	-22.39	50.00	14.89	2.28	10.44	Average

Note:

- Level(dBμV) = Read Level(dBμV) + LISN Factor(dB) + Cable Loss(dB)
- Over Limit(dB) = Level(dBμV) – Limit Line(dBμV)



Appendix C. Radiated Spurious Emission

Band 1 - 5150~5250MHz
WIFI 802.11a (Band Edge @ 3m)

WIFI	Note	Frequency	Level	Over	Limit	Read	Antenna	Path	Preamp	Ant	Table	Peak	Pol.
Ant.				Limit	Line	Level	Factor	Loss	Factor	Pos	Pos	Avg.	
1+2		(MHz)	(dBμV/m)	(dB)	(dBμV/m)	(dBμV)	(dB/m)	(dB)	(dB)	(cm)	(deg)	(P/A)	(H/V)
802.11a CH 36 5180MHz		5149.6	59.44	-14.56	74	46.34	35.33	11.09	33.32	167	171	P	H
		5150	49.37	-4.63	54	36.27	35.33	11.09	33.32	167	171	A	H
	*	5176	110.45	-	-	97.29	35.36	11.12	33.32	167	171	P	H
		5176	103.96	-	-	90.8	35.36	11.12	33.32	167	171	A	H
		5149.954	61.69	-12.31	74	48.59	35.33	11.09	33.32	300	167	P	V
		5150	50.33	-3.67	54	37.23	35.33	11.09	33.32	300	167	A	V
	*	5176	112.73	-	-	99.57	35.36	11.12	33.32	300	167	P	V
		5176	105.55	-	-	92.39	35.36	11.12	33.32	300	167	A	V
Remark	1. No other spurious found. 2. All results are PASS against Peak and Average limit line.												



Band 1 5150~5250MHz

WIFI 802.11a (Harmonic @ 3m)

WIFI Ant. 1+2	Note	Frequency (MHz)	Level (dBμV/m)	Over Limit (dB)	Limit Line (dBμV/m)	Read Level (dBμV)	Antenna Factor (dB/m)	Path Loss (dB)	Preamp Factor (dB)	Ant Pos (cm)	Table Pos (deg)	Peak Avg. (P/A)	Pol. (H/V)
802.11a CH 36 5180MHz		10360	46.14	-22.16	68.3	52.74	39.6	15.88	62.08	300	0	P	H
		10360	47.01	-21.29	68.3	53.61	39.6	15.88	62.08	100	360	P	V
802.11a CH 44 5220MHz		10440	47.1	-21.2	68.3	53.58	39.63	15.94	62.05	100	360	P	H
		10440	47.69	-20.61	68.3	54.17	39.63	15.94	62.05	100	360	P	V
802.11a CH 48 5240MHz		10480	45.62	-22.68	68.3	52	39.66	15.98	62.02	100	360	P	H
		10480	45.02	-23.28	68.3	51.4	39.66	15.98	62.02	100	360	P	V
Remark	1. No other spurious found. 2. All results are PASS against Peak and Average limit line.												



Band 1 5150~5250MHz
WIFI 802.11ac VHT20 (Band Edge @ 3m)

WIFI Ant. 1+2	Note	Frequency (MHz)	Level (dBμV/m)	Over Limit (dB)	Limit Line (dBμV/m)	Read Level (dBμV)	Antenna Factor (dB/m)	Path Loss (dB)	Preamp Factor (dB)	Ant Pos (cm)	Table Pos (deg)	Peak Avg. (P/A)	Pol. (H/V)
802.11ac VHT20 CH 36 5180MHz		5149.44	57.33	-16.67	74	44.23	35.33	11.09	33.32	116	185	P	H
		5150	47.68	-6.32	54	34.58	35.33	11.09	33.32	116	185	A	H
	*	5182	111.34	-	-	98.18	35.36	11.12	33.32	116	185	P	H
		5182	104.16	-	-	91	35.36	11.12	33.32	116	185	A	H
		5145.28	58.66	-15.34	74	45.56	35.33	11.09	33.32	284	164	P	V
		5150	49.88	-4.12	54	36.78	35.33	11.09	33.32	284	164	A	V
	*	5182	111.94	-	-	98.78	35.36	11.12	33.32	284	164	P	V
		5182	104.3	-	-	91.14	35.36	11.12	33.32	284	164	A	V
Remark	1. No other spurious found. 2. All results are PASS against Peak and Average limit line.												



Band 1 5150~5250MHz
WIFI 802.11ac VHT20 (Harmonic @ 3m)

WIFI Ant. 1+2	Note	Frequency (MHz)	Level (dBμV/m)	Over Limit (dB)	Limit Line (dBμV/m)	Read Level (dBμV)	Antenna Factor (dB/m)	Path Loss (dB)	Preamp Factor (dB)	Ant Pos (cm)	Table Pos (deg)	Peak Avg. (P/A)	Pol. (H/V)
802.11ac VHT20		10360	46.44	-21.86	68.3	53.04	39.6	15.88	62.08	100	360	P	H
CH 36		10360	46.84	-21.46	68.3	53.44	39.6	15.88	62.08	100	360	P	V
5180MHz													
802.11ac VHT20		10440	47.53	-20.77	68.3	54.01	39.63	15.94	62.05	100	360	P	H
CH 44		10440	46.7	-21.6	68.3	53.18	39.63	15.94	62.05	100	360	P	V
5220MHz													
802.11ac VHT20		10480	47.24	-21.06	68.3	53.62	39.66	15.98	62.02	100	360	P	H
CH 48		10480	47.12	-21.18	68.3	53.5	39.66	15.98	62.02	100	360	P	V
5240MHz													
Remark	1. No other spurious found. 2. All results are PASS against Peak and Average limit line.												



Band 1 5150~5250MHz
WIFI 802.11ac VHT40 (Band Edge @ 3m)

Table with 14 columns: WIFI Ant. 1+2, Note, Frequency (MHz), Level (dBµV/m), Over Limit (dB), Limit Line (dBµV/m), Read Level (dBµV), Antenna Factor (dB/m), Path Loss (dB), Preamp Factor (dB), Ant Pos (cm), Table Pos (deg), Peak Avg. (P/A), Pol. (H/V). Rows include test data for 802.11ac VHT40 CH 38 5190MHz and a Remark section.



Band 1 5150~5250MHz
WIFI 802.11ac VHT40 (Harmonic @ 3m)

WIFI Ant. 1+2	Note	Frequency (MHz)	Level (dBμV/m)	Over Limit (dB)	Limit Line (dBμV/m)	Read Level (dBμV)	Antenna Factor (dB/m)	Path Loss (dB)	Preamp Factor (dB)	Ant Pos (cm)	Table Pos (deg)	Peak Avg. (P/A)	Pol. (H/V)
802.11ac VHT40		10380	45.23	-23.07	68.3	51.8	39.61	15.89	62.07	300	0	P	H
CH 38 5190MHz		10380	45.96	-22.34	68.3	52.53	39.61	15.89	62.07	100	360	P	V
802.11ac VHT40		10460	46.21	-22.09	68.3	52.66	39.64	15.95	62.04	100	360	P	H
CH 46 5230MHz		10460	46.44	-21.86	68.3	52.89	39.64	15.95	62.04	100	360	P	V
Remark	1. No other spurious found. 2. All results are PASS against Peak and Average limit line.												



Band 1 5150~5250MHz
WIFI 802.11ac VHT80 (Band Edge @ 3m)

Table with 14 columns: WIFI Ant. 1+2, Note, Frequency (MHz), Level (dBµV/m), Over Limit (dB), Limit Line (dBµV/m), Read Level (dBµV), Antenna Factor (dB/m), Path Loss (dB), Preamp Factor (dB), Ant Pos (cm), Table Pos (deg), Peak Avg. (P/A), Pol. (H/V). Rows include data for 802.11ac VHT80 CH 42 5210MHz and a Remark section.



Band 1 5150~5250MHz
WIFI 802.11ac VHT80 (Harmonic @ 3m)

Table with 14 columns: WIFI Ant. 1+2, Note, Frequency (MHz), Level (dBµV/m), Over Limit (dB), Limit Line (dBµV/m), Read Level (dBµV), Antenna Factor (dB/m), Path Loss (dB), Preamp Factor (dB), Ant Pos (cm), Table Pos (deg), Peak Avg. (P/A), Pol. (H/V). Rows include 802.11ac VHT80 and CH 42 5210MHz.

Remark

- 1. No other spurious found.
2. All results are PASS against Peak and Average limit line.



Band 2 - 5250~5350MHz
WIFI 802.11a (Band Edge @ 3m)

Table with 14 columns: WIFI Ant. 1+2, Note, Frequency (MHz), Level (dBµV/m), Over Limit (dB), Limit Line (dBµV/m), Read Level (dBµV), Antenna Factor (dB/m), Path Loss (dB), Preamp Factor (dB), Ant Pos (cm), Table Pos (deg), Peak Avg. (P/A), Pol. (H/V). Rows include data for 802.11a CH 64 5320MHz and a Remark section.



Band 2 5250~5350MHz

WIFI 802.11a (Harmonic @ 3m)

WIFI Ant. 1+2	Note	Frequency (MHz)	Level (dBμV/m)	Over Limit (dB)	Limit Line (dBμV/m)	Read Level (dBμV)	Antenna Factor (dB/m)	Path Loss (dB)	Preamp Factor (dB)	Ant Pos (cm)	Table Pos (deg)	Peak Avg. (P/A)	Pol. (H/V)
802.11a CH 52 5260MHz		10520	46.01	-22.29	68.3	52.33	39.68	16.01	62.01	300	0	P	H
		10520	45.4	-22.9	68.3	51.72	39.68	16.01	62.01	100	360	P	V
802.11a CH 60 5300MHz		10600	48.04	-25.96	74	54.21	39.72	16.08	61.97	300	0	P	H
		10600	47.96	-26.04	74	54.13	39.72	16.08	61.97	100	360	P	V
802.11a CH 64 5320MHz		10640	45.66	-28.34	74	51.76	39.74	16.11	61.95	300	0	P	H
		10640	45.88	-28.12	74	51.98	39.74	16.11	61.95	100	360	P	V
Remark	1. No other spurious found. 2. All results are PASS against Peak and Average limit line.												



Band 2 5250~5350MHz
WIFI 802.11ac VHT20 (Band Edge @ 3m)

Table with 14 columns: WIFI Ant. 1+2, Note, Frequency (MHz), Level (dBµV/m), Over Limit (dB), Limit Line (dBµV/m), Read Level (dBµV), Antenna Factor (dB/m), Path Loss (dB), Preamp Factor (dB), Ant Pos (cm), Table Pos (deg), Peak Avg. (P/A), Pol. (H/V). Rows include test results for 802.11ac VHT20 CH 64 5320MHz and a Remark section.



Band 2 5250~5350MHz
WIFI 802.11ac VHT20 (Harmonic @ 3m)

Table with 14 columns: WIFI Ant. 1+2, Note, Frequency (MHz), Level (dBµV/m), Over Limit (dB), Limit Line (dBµV/m), Read Level (dBµV), Antenna Factor (dB/m), Path Loss (dB), Preamp Factor (dB), Ant Pos (cm), Table Pos (deg), Peak Avg. (P/A), Pol. (H/V). Rows include data for channels 52, 60, and 64 at frequencies 10520, 10600, and 10640 MHz.



Band 2 5250~5350MHz
WIFI 802.11ac VHT40 (Band Edge @ 3m)

WIFI Ant. 1+2	Note	Frequency (MHz)	Level (dBμV/m)	Over Limit (dB)	Limit Line (dBμV/m)	Read Level (dBμV)	Antenna Factor (dB/m)	Path Loss (dB)	Preamp Factor (dB)	Ant Pos (cm)	Table Pos (deg)	Peak Avg. (P/A)	Pol. (H/V)
802.11ac VHT40 CH 62 5310MHz		5134.4	54.54	-19.46	74	41.48	35.31	11.07	33.32	100	176	P	H
		5146.24	44.82	-9.18	54	31.72	35.33	11.09	33.32	100	176	A	H
	*	5314	104.59	-	-	91.17	35.49	11.25	33.32	100	176	P	H
		5314	98.03	-	-	84.61	35.49	11.25	33.32	100	176	A	H
		5350.8	55.42	-18.58	74	41.94	35.52	11.28	33.32	100	176	P	H
		5350.7	46.84	-7.16	54	33.36	35.52	11.28	33.32	100	176	A	H
		5122.24	55.86	-18.14	74	42.84	35.3	11.05	33.33	243	166	P	V
		5146.56	44.92	-9.08	54	31.82	35.33	11.09	33.32	243	166	A	V
	*	5308	107.55	-	-	94.15	35.48	11.24	33.32	243	166	P	V
		5308	99.87	-	-	86.47	35.48	11.24	33.32	243	166	A	V
		5350.5	58.16	-15.84	74	44.68	35.52	11.28	33.32	243	166	P	V
		5350.6	49.43	-4.57	54	35.95	35.52	11.28	33.32	243	166	A	V
Remark	1. No other spurious found. 2. All results are PASS against Peak and Average limit line.												



Band 2 5250~5350MHz
WIFI 802.11ac VHT40 (Harmonic @ 3m)

WIFI Ant. 1+2	Note	Frequency (MHz)	Level (dBμV/m)	Over Limit (dB)	Limit Line (dBμV/m)	Read Level (dBμV)	Antenna Factor (dB/m)	Path Loss (dB)	Preamp Factor (dB)	Ant Pos (cm)	Table Pos (deg)	Peak Avg. (P/A)	Pol. (H/V)
802.11ac VHT40		10540	44.85	-23.45	68.3	51.14	39.69	16.02	62	100	360	P	H
CH 54 5270MHz		10540	45.32	-22.98	68.3	51.61	39.69	16.02	62	100	360	P	V
802.11ac VHT40		10620	45.83	-28.17	74	51.96	39.73	16.1	61.96	100	360	P	H
CH 62 5310MHz		10620	46.06	-27.94	74	52.19	39.73	16.1	61.96	100	360	P	V
Remark	1. No other spurious found. 2. All results are PASS against Peak and Average limit line.												



Band 2 5250~5350MHz
WIFI 802.11ac VHT80 (Band Edge @ 3m)

WIFI Ant. 1+2	Note	Frequency (MHz)	Level (dBμV/m)	Over Limit (dB)	Limit Line (dBμV/m)	Read Level (dBμV)	Antenna Factor (dB/m)	Path Loss (dB)	Preamp Factor (dB)	Ant Pos (cm)	Table Pos (deg)	Peak Avg. (P/A)	Pol. (H/V)
802.11ac VHT80 CH 58 5290MHz		5118.88	54.65	-19.35	74	41.63	35.3	11.05	33.33	140	217	P	H
		5111.68	44.6	-9.4	54	31.58	35.3	11.05	33.33	140	217	A	H
	*	5290	97.34	-	-	83.98	35.46	11.22	33.32	140	217	P	H
		5290	89.51	-	-	76.15	35.46	11.22	33.32	140	217	A	H
		5362.1	55.85	-18.15	74	42.33	35.54	11.3	33.32	140	217	P	H
		5350.3	47.21	-6.79	54	33.73	35.52	11.28	33.32	140	217	A	H
		5138.24	54.99	-19.01	74	41.93	35.31	11.07	33.32	300	140	P	V
		5148.96	44.86	-9.14	54	31.76	35.33	11.09	33.32	300	140	A	V
	*	5290	100.93	-	-	87.57	35.46	11.22	33.32	300	140	P	V
		5290	93.32	-	-	79.96	35.46	11.22	33.32	300	140	A	V
		5350.2	58.37	-15.63	74	44.89	35.52	11.28	33.32	300	140	P	V
		5350.1	49.22	-4.78	54	35.74	35.52	11.28	33.32	300	140	A	V
Remark	1. No other spurious found. 2. All results are PASS against Peak and Average limit line.												



Band 2 5250~5350MHz
WIFI 802.11ac VHT80 (Harmonic @ 3m)

Table with 14 columns: WIFI Ant. 1+2, Note, Frequency (MHz), Level (dBµV/m), Over Limit (dB), Limit Line (dBµV/m), Read Level (dBµV), Antenna Factor (dB/m), Path Loss (dB), Preamp Factor (dB), Ant Pos (cm), Table Pos (deg), Peak Avg. (P/A), Pol. (H/V). Rows include 802.11ac VHT80 and CH 58 5290MHz.

Remark

- 1. No other spurious found.
2. All results are PASS against Peak and Average limit line.



Band 3 - 5470~5725MHz
WIFI 802.11a (Band Edge @ 3m)

WIFI Ant. 1+2	Note	Frequency (MHz)	Level (dBμV/m)	Over Limit (dB)	Limit Line (dBμV/m)	Read Level (dBμV)	Antenna Factor (dB/m)	Path Loss (dB)	Preamp Factor (dB)	Ant Pos (cm)	Table Pos (deg)	Peak Avg. (P/A)	Pol. (H/V)
802.11a CH 100 5500MHz		5442.48	55.41	-18.59	74	41.74	35.61	11.37	33.31	116	200	P	H
		5464.56	58.3	-10	68.3	44.56	35.64	11.41	33.31	116	200	P	H
		5422.32	46.29	-7.71	54	32.66	35.59	11.35	33.31	116	200	A	H
	*	5500	111.18	-	-	97.37	35.67	11.45	33.31	116	200	P	H
		5500	103.15	-	-	89.34	35.67	11.45	33.31	116	200	A	H
		5458.8	59.6	-14.4	74	45.9	35.62	11.39	33.31	299	161	P	V
		5468.24	65	-3.3	68.3	51.26	35.64	11.41	33.31	299	161	P	V
		5460	49.37	-4.63	54	35.67	35.62	11.39	33.31	299	161	A	V
	*	5500	114.52	-	-	100.71	35.67	11.45	33.31	299	161	P	V
		5500	107.42	-	-	93.61	35.67	11.45	33.31	299	161	A	V
802.11a CH 140 5700MHz		5728.04	60.7	-7.6	68.3	46.56	35.84	11.68	33.38	102	191	P	H
	*	5698	106.86	-	-	92.76	35.82	11.65	33.37	102	191	P	H
		5698	98.63	-	-	84.53	35.82	11.65	33.37	102	191	A	H
		5725.08	64.23	-4.07	68.3	50.09	35.84	11.68	33.38	210	179	P	V
	*	5698	111.83	-	-	97.73	35.82	11.65	33.37	210	179	P	V
	5698	104.72	-	-	90.62	35.82	11.65	33.37	210	179	A	V	
Remark	1. No other spurious found. 2. All results are PASS against Peak and Average limit line.												



Band 3 - 5470~5725MHz
WIFI 802.11a (Harmonic @ 3m)

WIFI Ant. 1+2	Note	Frequency (MHz)	Level (dBμV/m)	Over Limit (dB)	Limit Line (dBμV/m)	Read Level (dBμV)	Antenna Factor (dB/m)	Path Loss (dB)	Preamp Factor (dB)	Ant Pos (cm)	Table Pos (deg)	Peak Avg. (P/A)	Pol. (H/V)
802.11a CH 100 5500MHz		11000	54.67	-19.33	74	60.11	39.93	16.42	61.79	308	227	P	H
		11000	44.47	-9.53	54	49.91	39.93	16.42	61.79	308	227	A	H
		11000	52.36	-21.64	74	57.8	39.93	16.42	61.79	300	206	P	V
		11000	43.26	-10.74	54	48.7	39.93	16.42	61.79	300	206	A	V
802.11a CH 116 5580MHz		11160	54.31	-19.69	74	59.56	40.02	16.57	61.84	389	266	P	H
		11160	44.92	-9.08	54	50.17	40.02	16.57	61.84	389	266	A	H
		11160	54.15	-19.85	74	59.4	40.02	16.57	61.84	319	213	P	V
		11160	44.37	-9.63	54	49.62	40.02	16.57	61.84	319	213	A	V
802.11a CH 140 5700MHz		11400	45.8	-28.2	74	50.77	40.15	16.79	61.91	300	0	P	H
		11400	46.92	-27.08	74	51.89	40.15	16.79	61.91	100	360	P	V
Remark	1. No other spurious found. 2. All results are PASS against Peak and Average limit line.												



Band 3 - 5470~5725MHz
WIFI 802.11ac VHT20 (Band Edge @ 3m)

WIFI Ant. 1+2	Note	Frequency (MHz)	Level (dBμV/m)	Over Limit (dB)	Limit Line (dBμV/m)	Read Level (dBμV)	Antenna Factor (dB/m)	Path Loss (dB)	Preamp Factor (dB)	Ant Pos (cm)	Table Pos (deg)	Peak Avg. (P/A)	Pol. (H/V)
802.11ac VHT20 CH 100 5500MHz		5459.28	54.94	-19.06	74	41.24	35.62	11.39	33.31	129	200	P	H
		5467.6	59.08	-9.22	68.3	45.34	35.64	11.41	33.31	129	200	P	H
		5421.52	45.87	-8.13	54	32.24	35.59	11.35	33.31	129	200	A	H
	*	5500	109.63	-	-	95.82	35.67	11.45	33.31	129	200	P	H
		5500	102.84	-	-	89.03	35.67	11.45	33.31	129	200	A	H
		5448.4	59.71	-14.29	74	46.01	35.62	11.39	33.31	295	167	P	V
		5468.08	63.77	-4.53	68.3	50.03	35.64	11.41	33.31	295	167	P	V
		5459.76	47.96	-6.04	54	34.26	35.62	11.39	33.31	295	167	A	V
	*	5500	112.89	-	-	99.08	35.67	11.45	33.31	295	167	P	V
	5500	105.86	-	-	92.05	35.67	11.45	33.31	295	167	A	V	
802.11ac VHT20 CH 140 5700MHz		5726.04	61.05	-7.25	68.3	46.91	35.84	11.68	33.38	101	197	P	H
	*	5698	105.75	-	-	91.65	35.82	11.65	33.37	101	197	P	H
		5698	99.28	-	-	85.18	35.82	11.65	33.37	101	197	A	H
		5728.68	62.95	-5.35	68.3	48.81	35.84	11.68	33.38	211	166	P	V
	*	5698	110.46	-	-	96.36	35.82	11.65	33.37	211	166	P	V
	5698	102.39	-	-	88.29	35.82	11.65	33.37	211	166	A	V	
Remark	1. No other spurious found. 2. All results are PASS against Peak and Average limit line.												



Band 3 - 5470~5725MHz
WIFI 802.11ac VHT20 (Harmonic @ 3m)

WIFI Ant. 1+2	Note	Frequency (MHz)	Level (dBμV/m)	Over Limit (dB)	Limit Line (dBμV/m)	Read Level (dBμV)	Antenna Factor (dB/m)	Path Loss (dB)	Preamp Factor (dB)	Ant Pos (cm)	Table Pos (deg)	Peak Avg. (P/A)	Pol. (H/V)
802.11ac VHT20 CH 100 5500MHz		11000	53.43	-20.57	74	58.87	39.93	16.42	61.79	306	243	P	H
		11000	43.13	-10.87	54	48.57	39.93	16.42	61.79	306	243	A	H
		11000	49.95	-24.05	74	55.39	39.93	16.42	61.79	100	360	P	V
802.11ac VHT20 CH 116 5580MHz		11160	53.28	-20.72	74	58.53	40.02	16.57	61.84	315	266	P	H
		11160	43.62	-10.38	54	48.87	40.02	16.57	61.84	315	226	A	H
		11160	53.57	-20.43	74	58.82	40.02	16.57	61.84	307	221	P	V
		11160	43.66	-10.34	54	48.91	40.02	16.57	61.84	307	221	A	V
802.11ac VHT20 CH 140 5700MHz		11400	46.77	-27.23	74	51.74	40.15	16.79	61.91	300	0	P	H
		11400	47.05	-26.95	74	52.02	40.15	16.79	61.91	100	360	P	V
Remark	1. No other spurious found. 2. All results are PASS against Peak and Average limit line.												



Band 3 - 5470~5725MHz
WIFI 802.11ac VHT40 (Band Edge @ 3m)

WIFI Ant. 1+2	Note	Frequency (MHz)	Level (dBμV/m)	Over Limit (dB)	Limit Line (dBμV/m)	Read Level (dBμV)	Antenna Factor (dB/m)	Path Loss (dB)	Preamp Factor (dB)	Ant Pos (cm)	Table Pos (deg)	Peak Avg. (P/A)	Pol. (H/V)
802.11ac VHT40 CH 102 5510MHz		5450.64	56.02	-17.98	74	42.32	35.62	11.39	33.31	141	208	P	H
		5467.12	57.99	-10.31	68.3	44.25	35.64	11.41	33.31	141	208	P	H
		5456.4	46.57	-7.43	54	32.87	35.62	11.39	33.31	141	208	A	H
	*	5512	107.15	-	-	93.34	35.67	11.45	33.31	141	208	P	H
		5512	101.56	-	-	87.75	35.67	11.45	33.31	141	208	A	H
		5759.64	54.8	-13.5	68.3	40.64	35.85	11.71	33.4	141	208	P	H
		5452.72	60.15	-13.85	74	46.45	35.62	11.39	33.31	205	167	P	V
		5467.76	61.61	-6.69	68.3	47.87	35.64	11.41	33.31	205	167	P	V
		5459.12	49.45	-4.55	54	35.75	35.62	11.39	33.31	205	167	A	V
	*	5506	110.18	-	-	96.37	35.67	11.45	33.31	205	167	P	V
		5506	103.05	-	-	89.24	35.67	11.45	33.31	205	167	A	V
		5744.6	55.37	-12.93	68.3	41.22	35.85	11.69	33.39	205	167	P	V
802.11ac VHT40 CH 134 5670MHz		5355.6	55.06	-18.94	74	41.58	35.52	11.28	33.32	101	206	P	H
		5469.68	55.29	-13.01	68.3	41.55	35.64	11.41	33.31	101	206	P	H
		5455.76	44.65	-9.35	54	30.95	35.62	11.39	33.31	101	206	A	H
	*	5668	107.66	-	-	93.57	35.82	11.63	33.36	101	206	P	H
		5668	100.07	-	-	85.98	35.82	11.63	33.36	101	206	A	H
		5725.08	64.12	-4.18	68.3	49.98	35.84	11.68	33.38	101	206	P	H
		5429.2	54.45	-19.55	74	40.78	35.61	11.37	33.31	239	167	P	V
		5468.08	54.46	-13.84	68.3	40.72	35.64	11.41	33.31	239	167	P	V
		5460	44.99	-9.01	54	31.29	35.62	11.39	33.31	239	167	A	V
	*	5674	111.32	-	-	97.24	35.82	11.63	33.37	239	167	P	V
	5674	104.36	-	-	90.28	35.82	11.63	33.37	239	167	A	V	
	5726.6	64.03	-4.27	68.3	49.89	35.84	11.68	33.38	239	167	P	V	
Remark	1. No other spurious found. 2. All results are PASS against Peak and Average limit line.												



Band 3 - 5470~5725MHz
WIFI 802.11ac VHT40 (Harmonic @ 3m)

WIFI Ant. 1+2	Note	Frequency (MHz)	Level (dBμV/m)	Over Limit (dB)	Limit Line (dBμV/m)	Read Level (dBμV)	Antenna Factor (dB/m)	Path Loss (dB)	Preamp Factor (dB)	Ant Pos (cm)	Table Pos (deg)	Peak Avg. (P/A)	Pol. (H/V)
802.11ac VHT40 CH 102 5510MHz		11020	46.97	-27.03	74	52.39	39.94	16.44	61.8	100	360	P	H
802.11ac VHT40 CH 110 5550MHz		11100	46.92	-27.08	74	52.25	39.98	16.51	61.82	100	360	P	H
802.11ac VHT40 CH 134 5670MHz		11340	47.43	-26.57	74	52.48	40.11	16.73	61.89	100	360	P	H
802.11ac VHT40 CH 102 5510MHz		11020	45.84	-28.16	74	51.26	39.94	16.44	61.8	100	360	P	V
802.11ac VHT40 CH 110 5550MHz		11100	46.44	-27.56	74	51.77	39.98	16.51	61.82	100	360	P	V
802.11ac VHT40 CH 134 5670MHz		11340	46.84	-27.16	74	51.89	40.11	16.73	61.89	100	360	P	V
Remark	1. No other spurious found. 2. All results are PASS against Peak and Average limit line.												



Band 3 - 5470~5725MHz
WIFI 802.11ac VHT80 (Band Edge @ 3m)

WIFI Ant. 1+2	Note	Frequency (MHz)	Level (dBμV/m)	Over Limit (dB)	Limit Line (dBμV/m)	Read Level (dBμV)	Antenna Factor (dB/m)	Path Loss (dB)	Preamp Factor (dB)	Ant Pos (cm)	Table Pos (deg)	Peak Avg. (P/A)	Pol. (H/V)
802.11ac VHT80 CH 106 5530MHz		5455.12	55.78	-18.22	74	42.08	35.62	11.39	33.31	123	195	P	H
		5468.24	56.65	-11.65	68.3	42.91	35.64	11.41	33.31	123	195	P	H
		5458	46.95	-7.05	54	33.25	35.62	11.39	33.31	123	195	A	H
	*	5536	97.93	-	-	84.06	35.7	11.49	33.32	123	195	P	H
		5536	92.52	-	-	78.65	35.7	11.49	33.32	123	195	A	H
		5741.24	54.67	-13.63	68.3	40.51	35.85	11.69	33.38	123	195	P	H
		5457.68	57.21	-16.79	74	43.51	35.62	11.39	33.31	298	169	P	V
		5469.2	59.21	-9.09	68.3	45.47	35.64	11.41	33.31	298	169	P	V
		5458	49.84	-4.16	54	36.14	35.62	11.39	33.31	298	169	A	V
	*	5536	102.65	-	-	88.78	35.7	11.49	33.32	298	169	P	V
		5536	95.49	-	-	81.62	35.7	11.49	33.32	298	169	A	V
		5732.44	54.7	-13.6	68.3	40.56	35.84	11.68	33.38	298	169	P	V
802.11ac VHT80 CH 122 5610MHz		5459.12	55.84	-18.16	74	42.14	35.62	11.39	33.31	100	196	P	H
		5461.52	56.1	-12.2	68.3	42.4	35.62	11.39	33.31	100	196	P	H
		5460	46.29	-7.71	54	32.59	35.62	11.39	33.31	100	196	A	H
	*	5602	104.36	-	-	90.36	35.77	11.57	33.34	100	196	P	H
		5602	96.51	-	-	82.51	35.77	11.57	33.34	100	196	A	H
		5725.08	60.68	-7.62	68.3	46.54	35.84	11.68	33.38	100	196	P	H
		5458.64	56.66	-17.34	74	42.96	35.62	11.39	33.31	207	170	P	V
		5468.08	59.13	-9.17	68.3	45.39	35.64	11.41	33.31	207	170	P	V
		5459.92	47.98	-6.02	54	34.28	35.62	11.39	33.31	207	170	A	V
	*	5608	109.17	-	-	95.17	35.77	11.57	33.34	207	170	P	V
	5608	101.97	-	-	87.97	35.77	11.57	33.34	207	170	A	V	
	5725	64.89	-3.41	68.3	50.75	35.84	11.68	33.38	207	170	P	V	
Remark	1. No other spurious found. 2. All results are PASS against Peak and Average limit line.												



Band 3 5470~5725MHz
WIFI 802.11ac VHT80 (Harmonic @ 3m)

WIFI Ant. 1+2	Note	Frequency (MHz)	Level (dBμV/m)	Over Limit (dB)	Limit Line (dBμV/m)	Read Level (dBμV)	Antenna Factor (dB/m)	Path Loss (dB)	Preamp Factor (dB)	Ant Pos (cm)	Table Pos (deg)	Peak Avg. (P/A)	Pol. (H/V)
802.11ac VHT80		11060	47.4	-26.6	74	52.76	39.97	16.48	61.81	300	0	P	H
CH 106 5530MHz		11060	46.18	-27.82	74	51.54	39.97	16.48	61.81	100	360	P	V
802.11ac VHT80		11220	46.63	-27.37	74	51.82	40.05	16.62	61.86	300	0	P	H
CH 122 5610MHz		11220	46.78	-27.22	74	51.97	40.05	16.62	61.86	100	360	P	V
Remark	1. No other spurious found. 2. All results are PASS against Peak and Average limit line.												



Band 3 - Straddle Channel
WIFI 802.11a (Band Edge @ 3m)

Table with 14 columns: WIFI, Note, Frequency, Level, Over, Limit, Read, Antenna, Path, Preamp, Ant, Table, Peak, Pol. It contains test results for 802.11a CH 144 at 5720MHz and a Remark section.



Band 3 - Straddle Channel
WIFI 802.11a (Harmonic @ 3m)

WIFI Ant. 1+2	Note	Frequency (MHz)	Level (dBμV/m)	Over Limit (dB)	Limit Line (dBμV/m)	Read Level (dBμV)	Antenna Factor (dB/m)	Path Loss (dB)	Preamp Factor (dB)	Ant Pos (cm)	Table Pos (deg)	Peak Avg. (P/A)	Pol. (H/V)
802.11a CH 144 5720MHz		11440	47.36	-26.64	74	52.3	40.16	16.82	61.92	300	0	P	H
		11440	48.99	-25.01	74	53.93	40.16	16.82	61.92	100	360	P	V
Remark	1. No other spurious found. 2. All results are PASS against Peak and Average limit line.												



Band 3 - Straddle Channel
WIFI 802.11ac VHT20 (Band Edge @ 3m)

Table with 14 columns: WIFI Ant. 1+2, Note, Frequency (MHz), Level (dBµV/m), Over Limit (dB), Limit Line (dBµV/m), Read Level (dBµV), Antenna Factor (dB/m), Path Loss (dB), Preamp Factor (dB), Ant Pos (cm), Table Pos (deg), Peak Avg. (P/A), Pol. (H/V). Rows include 802.11ac VHT20, CH 144, and 5720MHz. A Remark section follows with two points: 'No other spurious found.' and 'All results are PASS against Peak and Average limit line.'



Band 3 - Straddle Channel
WIFI 802.11ac VHT20 (Harmonic @ 3m)

Table with 14 columns: WIFI Ant. 1+2, Note, Frequency (MHz), Level (dBµV/m), Over Limit (dB), Limit Line (dBµV/m), Read Level (dBµV), Antenna Factor (dB/m), Path Loss (dB), Preamp Factor (dB), Ant Pos (cm), Table Pos (deg), Peak Avg. (P/A), Pol. (H/V). Rows include 802.11ac VHT20 CH 144 5720MHz.

Remark

- 1. No other spurious found.
2. All results are PASS against Peak and Average limit line.



Band 3 - Straddle Channel
WIFI 802.11ac VHT40 (Band Edge @ 3m)

Table with 14 columns: WIFI Ant. 1+2, Note, Frequency (MHz), Level (dBµV/m), Over Limit (dB), Limit Line (dBµV/m), Read Level (dBµV), Antenna Factor (dB/m), Path Loss (dB), Preamp Factor (dB), Ant Pos (cm), Table Pos (deg), Peak Avg. (P/A), Pol. (H/V). Rows include 802.11ac VHT40 and CH 142 5710MHz.

Remark
1. No other spurious found.
2. All results are PASS against Peak and Average limit line.



Band 3 - Straddle Channel
WIFI 802.11ac VHT40 (Harmonic @ 3m)

WIFI Ant. 1+2	Note	Frequency (MHz)	Level (dBμV/m)	Over Limit (dB)	Limit Line (dBμV/m)	Read Level (dBμV)	Antenna Factor (dB/m)	Path Loss (dB)	Preamp Factor (dB)	Ant Pos (cm)	Table Pos (deg)	Peak Avg. (P/A)	Pol. (H/V)
802.11ac VHT40		11420	46.08	-27.92	74	51.03	40.16	16.81	61.92	100	360	P	H
CH 142 5710MHz		11420	46.5	-27.5	74	51.45	40.16	16.81	61.92	100	360	P	V
Remark	1. No other spurious found. 2. All results are PASS against Peak and Average limit line.												



Band 3 - Straddle Channel
WIFI 802.11ac VHT80 (Band Edge @ 3m)

Table with 14 columns: WIFI Ant. 1+2, Note, Frequency (MHz), Level (dBµV/m), Over Limit (dB), Limit Line (dBµV/m), Read Level (dBµV), Antenna Factor (dB/m), Path Loss (dB), Preamp Factor (dB), Ant Pos (cm), Table Pos (deg), Peak Avg. (P/A), Pol. (H/V). Rows include 802.11ac VHT80 and CH 138 5690MHz.

Remark
1. No other spurious found.
2. All results are PASS against Peak and Average limit line.



Band 3 - Straddle Channel
WIFI 802.11ac VHT80 (Harmonic @ 3m)

Table with 14 columns: WIFI Ant. 1+2, Note, Frequency (MHz), Level (dBµV/m), Over Limit (dB), Limit Line (dBµV/m), Read Level (dBµV), Antenna Factor (dB/m), Path Loss (dB), Preamp Factor (dB), Ant Pos (cm), Table Pos (deg), Peak Avg. (P/A), Pol. (H/V). Rows include 802.11ac VHT80 CH 138 5690MHz and a Remark section.



Emission below 1GHz
WIFI 802.11a (LF @ 3m)

WIFI	Note	Frequency	Level	Over	Limit	Read	Antenna	Path	Preamp	Ant	Table	Peak	Pol.
Ant.				Limit	Line	Level	Factor	Loss	Factor	Pos	Pos	Avg.	
1+2		(MHz)	(dBμV/m)	(dB)	(dBμV/m)	(dBμV)	(dB/m)	(dB)	(dB)	(cm)	(deg)	(P/A)	(H/V)
802.11a LF		60.07	17.46	-22.54	40	41.64	13.4	0.92	38.5	-	-	P	H
		191.99	18.59	-24.91	43.5	38.31	16.49	2.07	38.28	-	-	P	H
		397.63	29.45	-16.55	46	40.24	22.65	3.01	36.45	-	-	P	H
		450.98	41.89	-4.11	46	52.34	23.62	3.2	37.27	100	0	P	H
		649.83	27.86	-18.14	46	33.01	25.9	3.85	34.9	-	-	P	H
		882.63	39.76	-6.24	46	40.85	27.33	4.49	32.91	-	-	P	H
		81.41	27.7	-12.3	40	51.17	14.2	1.23	38.9	-	-	P	V
		136.7	27.01	-16.49	43.5	46.36	17.66	1.72	38.73	-	-	P	V
		254.07	24.1	-21.9	46	40.75	19.46	2.39	38.5	-	-	P	V
		347.19	30.98	-15.02	46	44.53	21.33	2.8	37.68	-	-	P	V
		649.83	37.03	-8.97	46	42.18	25.9	3.85	34.9	-	-	P	V
	946.65	41.43	-4.57	46	40.85	27.87	4.65	31.94	100	360	P	V	
Remark	1. No other spurious found. 2. All results are PASS against limit line.												



Note symbol

*	Fundamental Frequency which can be ignored. However, the level of any unwanted emissions shall not exceed the level of the fundamental frequency.
!	Test result is over limit line.
P/A	Peak or Average
H/V	Horizontal or Vertical



A calculation example for radiated spurious emission is shown as below:

WIFI	Note	Frequency	Level	Over	Limit	Read	Antenna	Path	Preamp	Ant	Table	Peak	Pol.
Ant.				Limit	Line	Level	Factor	Loss	Factor	Pos	Pos	Avg.	
1		(MHz)	(dBμV/m)	(dB)	(dBμV/m)	(dBμV)	(dB/m)	(dB)	(dB)	(cm)	(deg)	(P/A)	(H/V)
802.11b		2390	55.45	-18.55	74	54.51	32.22	4.58	35.86	103	308	P	H
CH 01													
2412MHz		2390	43.54	-10.46	54	42.6	32.22	4.58	35.86	103	308	A	H

1. Path Loss(dB) = Cable loss(dB) + Filter loss(dB) + Attenuator loss(dB)
2. Level(dBμV/m) = Antenna Factor(dB/m) + Path Loss(dB) + Read Level(dBμV) - Preamp Factor(dB)
3. Over Limit(dB) = Level(dBμV/m) – Limit Line(dBμV/m)

For Peak Limit @ 2390MHz:

1. Level(dBμV/m)
= Antenna Factor(dB/m) + Path Loss(dB) + Read Level(dBμV) - Preamp Factor(dB)
= 32.22(dB/m) + 4.58(dB) + 54.51(dBμV) – 35.86 (dB)
= 55.45 (dBμV/m)
2. Over Limit(dB)
= Level(dBμV/m) – Limit Line(dBμV/m)
= 55.45(dBμV/m) – 74(dBμV/m)
= -18.55(dB)

For Average Limit @ 2390MHz:

1. Level(dBμV/m)
= Antenna Factor(dB/m) + Path Loss(dB) + Read Level(dBμV) - Preamp Factor(dB)
= 32.22(dB/m) + 4.58(dB) + 42.6(dBμV) – 35.86 (dB)
= 43.54 (dBμV/m)
2. Over Limit(dB) = Level(dBμV/m) – Limit Line(dBμV/m)
= 43.54(dBμV/m) – 54(dBμV/m)
= -10.46(dB)

Both peak and average measured complies with the limit line, so test result is “PASS”.



Appendix D. Duty Cycle Plots

Band	Duty Cycle(%)	T(ms)	1/T(kHz)	VBW Setting
802.11a	100	-	-	10Hz
802.11ac VHT20	100	-	-	10Hz
802.11ac VHT40	100	-	-	10Hz
802.11ac VHT80	100	-	-	10Hz



802.11a

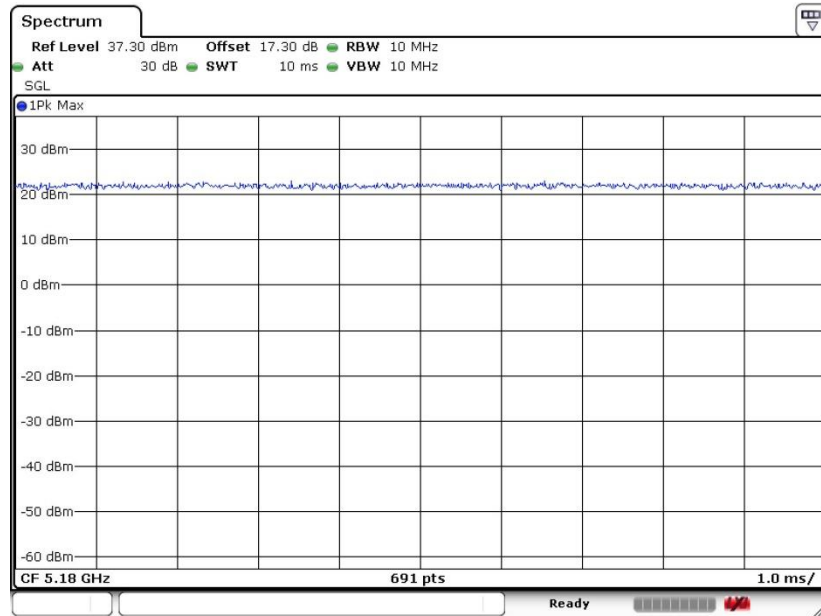

802.11ac VHT20

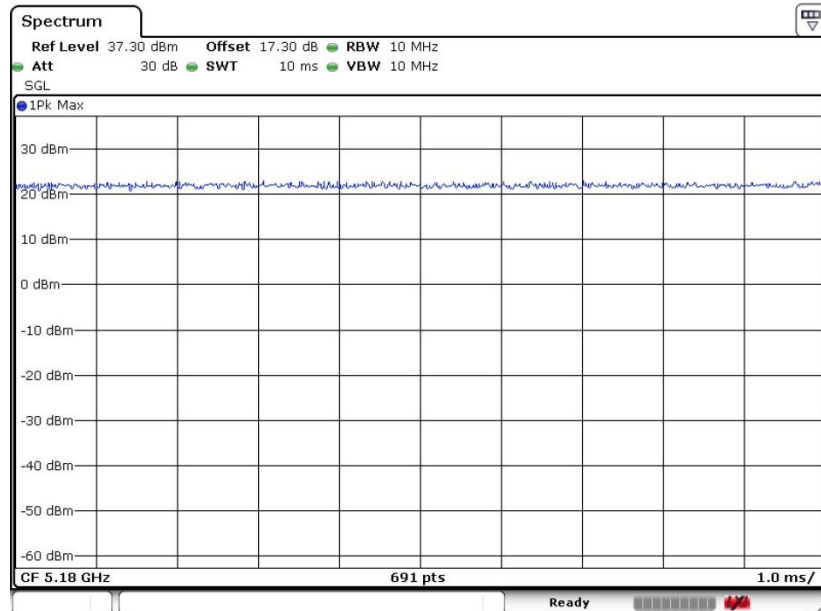



802.11ac VHT40

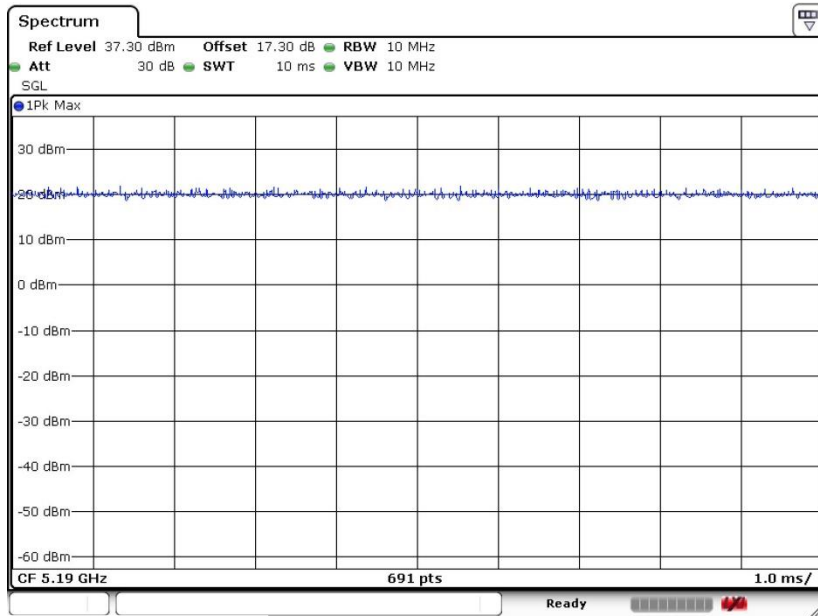

802.11ac VHT80

