



# FCC RF Test Report

**APPLICANT** : Butte L.L.C.  
**EQUIPMENT** : Wireless Device  
**MODEL NAME** : JK29LP  
**FCC ID** : 2AETK-1013  
**STANDARD** : FCC Part 15 Subpart C §15.247  
**CLASSIFICATION** : (DTS) Digital Transmission System

This is a variant report which is only valid together with the original test report. The testing was completed on Jul. 20, 2016. We, SPORTON INTERNATIONAL INC., would like to declare that the tested sample has been evaluated in accordance with the test procedures and has been in compliance with the applicable technical standards.

The test results in this report apply exclusively to the tested model / sample. Without written approval of SPORTON INTERNATIONAL INC., the test report shall not be reproduced except in full.

Reviewed by: Joseph Lin / Supervisor

Approved by: Jones Tsai / Manager



## **SPORTON INTERNATIONAL INC.**

No. 52, Hwa Ya 1<sup>st</sup> Rd., Hwa Ya Technology Park, Kwei-Shan District, Tao Yuan City, Taiwan, R.O.C.



# TABLE OF CONTENTS

**REVISION HISTORY..... 3**

**SUMMARY OF TEST RESULT ..... 4**

**1 GENERAL DESCRIPTION ..... 5**

    1.1 Applicant ..... 5

    1.2 Product Feature of Equipment Under Test..... 5

    1.3 Product Specification of Equipment Under Test..... 5

    1.4 Modification of EUT ..... 5

    1.5 Testing Location ..... 6

    1.6 Applicable Standards..... 6

**2 TEST CONFIGURATION OF EQUIPMENT UNDER TEST ..... 7**

    2.1 Carrier Frequency Channel ..... 7

    2.2 Test Mode..... 7

    2.3 Connection Diagram of Test System..... 8

    2.4 Support Unit used in test configuration and system ..... 8

    2.5 EUT Operation Test Setup ..... 8

    2.6 Measurement Results Explanation Example..... 9

**3 TEST RESULT ..... 10**

    3.1 6dB and 99% Bandwidth Measurement ..... 10

    3.2 Output Power Measurement..... 12

    3.3 Power Spectral Density Measurement ..... 13

    3.4 Conducted Band Edges and Spurious Emission Measurement ..... 15

    3.5 Radiated Band Edges and Spurious Emission Measurement ..... 22

    3.6 Antenna Requirements ..... 26

**4 LIST OF MEASURING EQUIPMENT ..... 27**

**5 UNCERTAINTY OF EVALUATION ..... 28**

**APPENDIX A. CONDUCTED TEST RESULTS**

**APPENDIX B. RADIATED SPURIOUS EMISSION**

**APPENDIX C. RADIATED SPURIOUS EMISSION PLOTS**

**APPENDIX D. DUTY CYCLE PLOTS**





### SUMMARY OF TEST RESULT

Report Section	FCC Rule	Description	Limit	Result	Remark
3.1	15.247(a)(2)	6dB Bandwidth	$\geq 0.5\text{MHz}$	Pass	-
3.1	-	99% Bandwidth	-	Pass	-
3.2	15.247(b)	Power Output Measurement	$\leq 30\text{dBm}$	Pass	-
3.3	15.247(e)	Power Spectral Density	$\leq 8\text{dBm}/3\text{kHz}$	Pass	-
3.4	15.247(d)	Conducted Band Edges	$\leq 20\text{dBc}$	Pass	-
		Conducted Spurious Emission		Pass	-
3.5	15.247(d)	Radiated Band Edges and Radiated Spurious Emission	15.209(a) & 15.247(d)	Pass	Under limit 0.73 dB at 2483.84 MHz
-	15.207	AC Conducted Emission	15.207(a)	N/A	EUT doesn't have related port
3.6	15.203 & 15.247(b)	Antenna Requirement	N/A	Pass	-



# 1 General Description

## 1.1 Applicant

**Butte L.L.C.**  
100 M Street, S.E., Suite 600  
Washington, District Of Columbia, 20003

## 1.2 Product Feature of Equipment Under Test

Product Feature	
Equipment	Wireless Device
Model Name	JK29LP
FCC ID	2AETK-1013
EUT supports Radios application	WLAN 11b/g/n HT20 Bluetooth v4.1 LE

## 1.3 Product Specification of Equipment Under Test

Standards-related Product Specification	
Tx/Rx Channel Frequency Range	802.11b/g/n : 2412 MHz ~ 2472 MHz
Maximum (Peak) Output Power to Antenna	802.11b : 17.61 dBm (0.0577 W) 802.11g : 21.45 dBm (0.1396 W) 802.11n HT20 : 21.92 dBm (0.1556 W)
99% Occupied Bandwidth	802.11b : 14.20MHz 802.11g : 17.90MHz 802.11n HT20 : 18.60MHz
Antenna Type	Fixed Internal Antenna with gain 1.17 dBi
Type of Modulation	802.11b : DSSS (DBPSK / DQPSK / CCK) 802.11g/n : OFDM (BPSK / QPSK / 16QAM / 64QAM)

## 1.4 Modification of EUT

No modifications are made to the EUT during all test items.



### 1.5 Testing Location

Sporton Lab is accredited to ISO 17025 by Taiwan Accreditation Foundation (TAF code : 1190) and the FCC designation No. TW1022 under the FCC 2.948(e) by Mutual Recognition Agreement (MRA) in FCC Test.

<b>Test Site</b>	SPORTON INTERNATIONAL INC.	
<b>Test Site Location</b>	No. 52, Hwa Ya 1 <sup>st</sup> Rd., Hwa Ya Technology Park, Kwei-Shan District, Tao Yuan City, Taiwan, R.O.C. TEL: +886-3-327-3456 FAX: +886-3-328-4978	
<b>Test Site No.</b>	<b>Sporton Site No.</b>	
	TH02-HY	03CH07-HY

**Note:** The test site complies with ANSI C63.4 2014 requirement.

### 1.6 Applicable Standards

According to the specifications of the manufacturer, the EUT must comply with the requirements of the following standards:

- ♦ FCC Part 15 Subpart C §15.247
- ♦ FCC KDB Publication No. 558074 D01 DTS Meas. Guidance v03r05
- ♦ ANSI C63.10-2013

**Remark:** All test items were verified and recorded according to the standards and without any deviation during the test.



## 2 Test Configuration of Equipment Under Test

The EUT has been associated with peripherals and configuration operated in a manner tended to maximize its emission characteristics in a typical application. Frequency range investigated: radiated emission (9 kHz to the 10th harmonic of the highest fundamental frequency or to 40 GHz, whichever is lower). For radiated measurement, pre-scanned in three orthogonal panels, X, Y, Z. The worst cases (Y plane) were recorded in this report.

### 2.1 Carrier Frequency Channel

Frequency Band	Channel	Freq. (MHz)	Channel	Freq. (MHz)
2400-2483.5 MHz	1	2412	8	2447
	2	2417	9	2452
	3	2422	10	2457
	4	2427	11	2462
	5	2432	12	2467
	6	2437	13	2472
	7	2442	-	-

### 2.2 Test Mode

Final test mode of conducted test items and radiated spurious emissions are considering the modulation and worse data rates as below table.

<2.4GHz>

Modulation	Data Rate
802.11b	1 Mbps
802.11g	6 Mbps
802.11n HT20	MCS0

## 2.3 Connection Diagram of Test System

<WLAN Tx Mode>

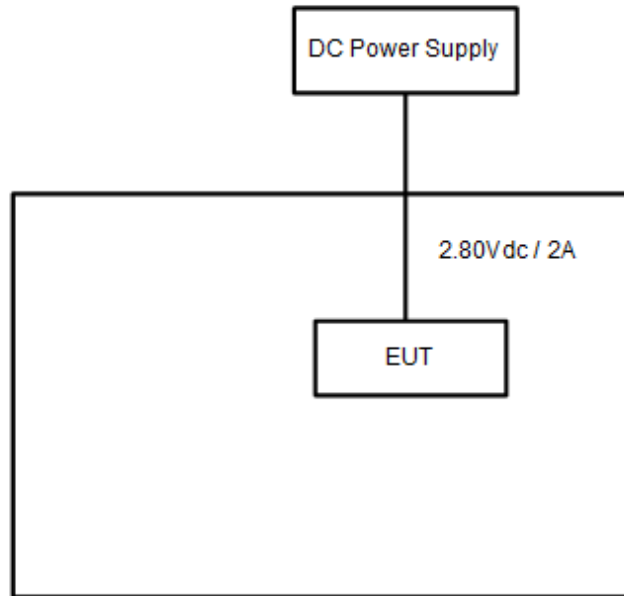

## 2.4 Support Unit used in test configuration and system

Item	Equipment	Trade Name	Model Name	FCC ID	Data Cable	Power Cord
1.	DC Power Supply	Topward	3303DR	N/A	N/A	Unshielded, 1.8 m

## 2.5 EUT Operation Test Setup

For WLAN RF test items, an engineering test program was provided and enabled to make EUT continuous transmit/receive.





## 2.6 Measurement Results Explanation Example

For all conducted test items:

The offset level is set in the spectrum analyzer to compensate the RF cable loss and attenuator factor between EUT conducted output port and spectrum analyzer. With the offset compensation, the spectrum analyzer reading level is exactly the EUT RF output level.

Example :

The spectrum analyzer offset is derived from RF cable loss and attenuator factor.

*Offset = RF cable loss + attenuator factor.*

Following shows an offset computation example with cable loss 4.2 dB and 10dB attenuator.

$$\begin{aligned} \text{Offset(dB)} &= \text{RF cable loss(dB)} + \text{attenuator factor(dB)}. \\ &= 4.2 + 10 = 14.2 \text{ (dB)} \end{aligned}$$

### 3 Test Result

#### 3.1 6dB and 99% Bandwidth Measurement

##### 3.1.1 Limit of 6dB and 99% Bandwidth

The minimum 6 dB bandwidth shall be at least 500 kHz.

##### 3.1.2 Measuring Instruments

The measuring equipment is listed in the section 4 of this test report.

##### 3.1.3 Test Procedures

1. The testing follows FCC KDB Publication No. 558074 DTS D01 Meas. Guidance v03r05.
2. The RF output of EUT was connected to the spectrum analyzer by RF cable and attenuator. The path loss was compensated to the results for each measurement.
3. Set to the maximum power setting and enable the EUT transmit continuously.
4. Make the measurement with the spectrum analyzer's resolution bandwidth (RBW) = 100 kHz. Set the Video bandwidth (VBW) = 300 kHz. In order to make an accurate measurement. The 6 dB bandwidth must be greater than 500 kHz.
5. For 99% Bandwidth Measurement, the spectrum analyzer's resolution bandwidth (RBW) = 1MHz and set the Video bandwidth (VBW) = 3MHz.
6. Measure and record the results in the test report.

##### 3.1.4 Test Setup





### 3.1.5 Test Result of 6dB and 99% Occupied Bandwidth

Please refer to Appendix A of this test report.

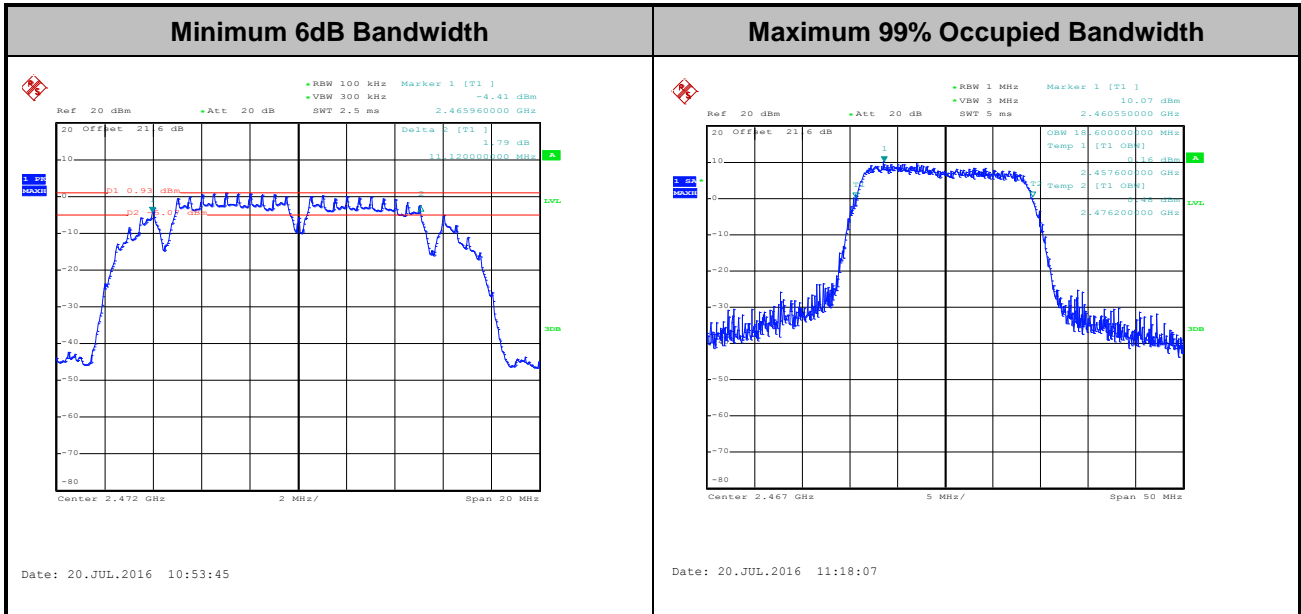

Note : The occupied channel bandwidth is maintained within the band of operation for all of the modulations.

## 3.2 Output Power Measurement

### 3.2.1 Limit of Output Power

For systems using digital modulation in the 2400-2483.5MHz, the limit for peak output power is 30dBm. If transmitting Antenna of directional gain greater than 6dBi are used the peak output power from the intentional radiator shall be reduced below the above stated value by the amount in dB that the directional gain of the Antenna exceeds 6 dBi. In case of point-to-point operation, the limit has to be reduced by 1dB for every 3dB that the directional gain of the Antenna exceeds 6dBi.

### 3.2.2 Measuring Instruments

The measuring equipment is listed in the section 4 of this test report.

### 3.2.3 Test Procedures

1. The testing follows the Measurement Procedure of FCC KDB No. 558074 DTS D01 Meas. Guidance v03r05 section 9.1.2 PKPM1 Peak power meter method.
2. The RF output of EUT was connected to the power meter by RF cable and attenuator. The path loss was compensated to the results for each measurement.
3. Set to the maximum power setting and enable the EUT transmit continuously.
4. Measure the conducted output power and record the results in the test report.

### 3.2.4 Test Setup

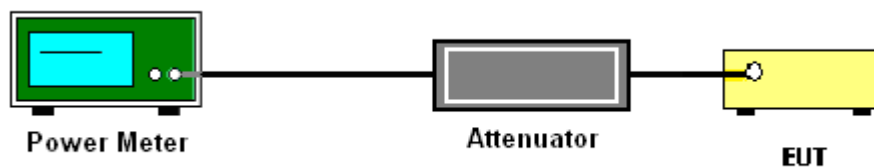

### 3.2.5 Test Result of Peak Output Power

Please refer to Appendix A of this test report.

### 3.2.6 Test Result of Average output Power (Reporting Only)

Please refer to Appendix A of this test report.

### 3.3 Power Spectral Density Measurement

#### 3.3.1 Limit of Power Spectral Density

The peak power spectral density shall not be greater than 8dBm in any 3kHz band at any time interval of continuous transmission.

#### 3.3.2 Measuring Instruments

The measuring equipment is listed in the section 4 of this test report.

#### 3.3.3 Test Procedures

1. The testing follows Measurement Procedure 10.2 Method PKPSD of FCC KDB Publication No. 558074 D01 DTS Meas. Guidance v03r05
2. The RF output of EUT was connected to the spectrum analyzer by RF cable and attenuator. The path loss was compensated to the results for each measurement.
3. Set to the maximum power setting and enable the EUT transmit continuously.
4. Make the measurement with the spectrum analyzer's resolution bandwidth (RBW) = 3 kHz. Video bandwidth VBW = 10 kHz In order to make an accurate measurement, set the span to 1.5 times DTS Channel Bandwidth. (6dB BW)
5. Detector = peak, Sweep time = auto couple, Trace mode = max hold, Allow trace to fully stabilize. Use the peak marker function to determine the maximum power level.
6. Measure and record the results in the test report.

#### 3.3.4 Test Setup

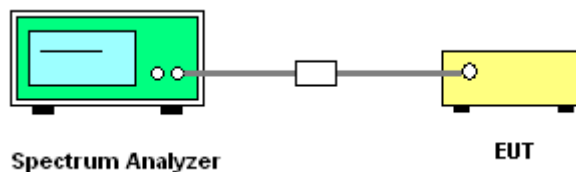



### 3.3.5 Test Result of Power Spectral Density

Please refer to Appendix A of this test report.

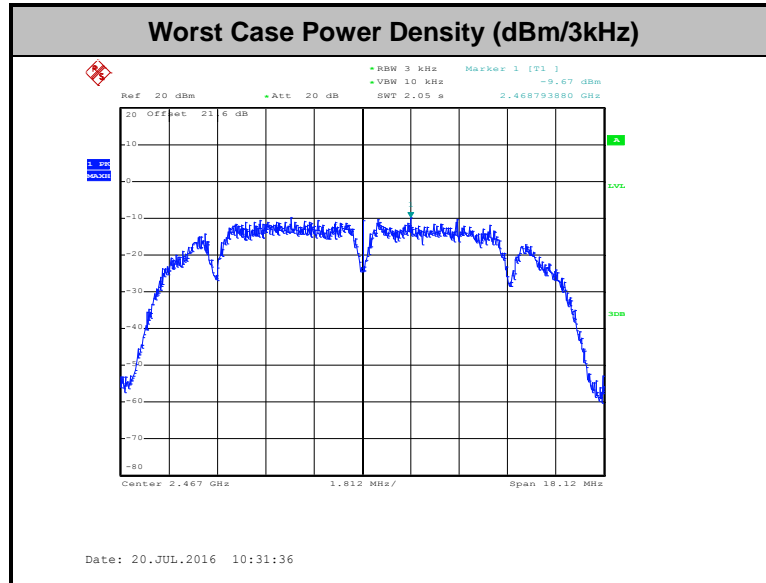

## 3.4 Conducted Band Edges and Spurious Emission Measurement

### 3.4.1 Limit of Conducted Band Edges and Spurious Emission Measurement

In any 100 kHz bandwidth outside of the authorized frequency band, the emissions which fall in the non-restricted bands shall be attenuated at least 20 dB / 30dB relative to the maximum PSD level in 100 kHz by RF conducted measurement and radiated emissions which fall in the restricted bands, as defined in Section 15.205(a), must also comply with the radiated emission limits specified in Section 15.209(a).

### 3.4.2 Measuring Instruments

The measuring equipment is listed in the section 4 of this test report.

### 3.4.3 Test Procedures

1. The testing follows FCC KDB Publication No. 558074 D01 DTS Meas. Guidance v03r05.
2. The RF output of EUT was connected to the spectrum analyzer by RF cable and attenuator. The path loss was compensated to the results for each measurement.
3. Set to the maximum power setting and enable the EUT transmit continuously.
4. Set RBW = 100 kHz, VBW=300 kHz, Peak Detector. Unwanted Emissions measured in any 100 kHz bandwidth outside of the authorized frequency band shall be attenuated by at least 20 dB relative to the maximum in-band peak PSD level in 100 kHz when maximum peak conducted output power procedure is used. If the transmitter complies with the conducted power limits based on the use of RMS averaging over a time interval, the attenuation required under this paragraph shall be 30 dB instead of 20 dB per 15.247(d).
5. Measure and record the results in the test report.
6. The RF fundamental frequency should be excluded against the limit line in the operating frequency band.

### 3.4.4 Test Setup

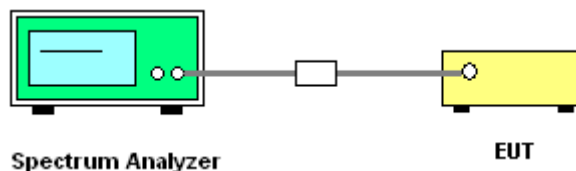



### 3.4.5 Test Result of Conducted Band Edges and Spurious Emission

Test Mode :	802.11b	Temperature :	21~25°C
Test Band :	2.4GHz High	Relative Humidity :	51~54%
Test Channel :	12	Test Engineer :	PH Yang

#### WLAN 802.11b Channel 12

##### 100kHz PSD reference Level

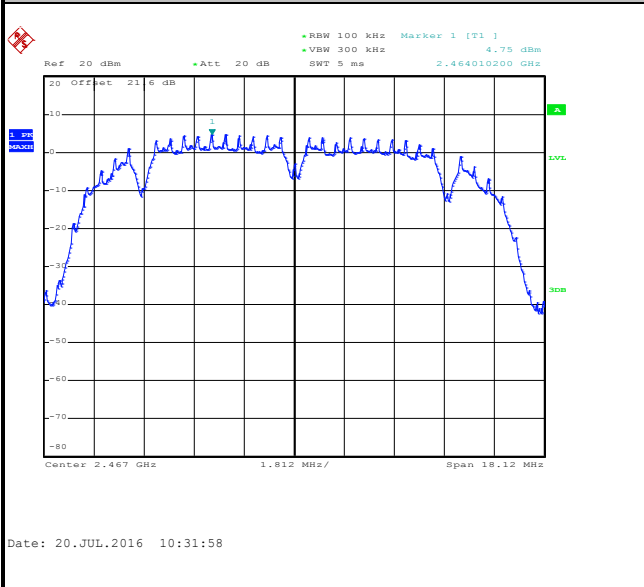

##### High Channel Plot

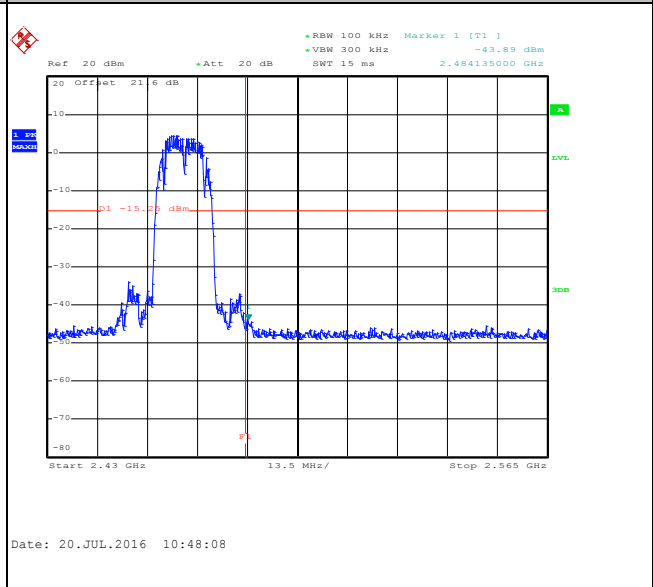

##### Spurious Emission 30MHz~3GHz

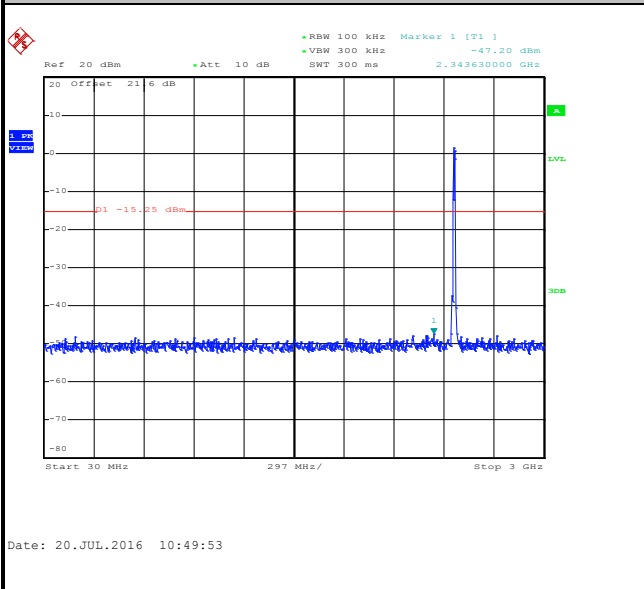

##### Spurious Emission 2GHz~25GHz

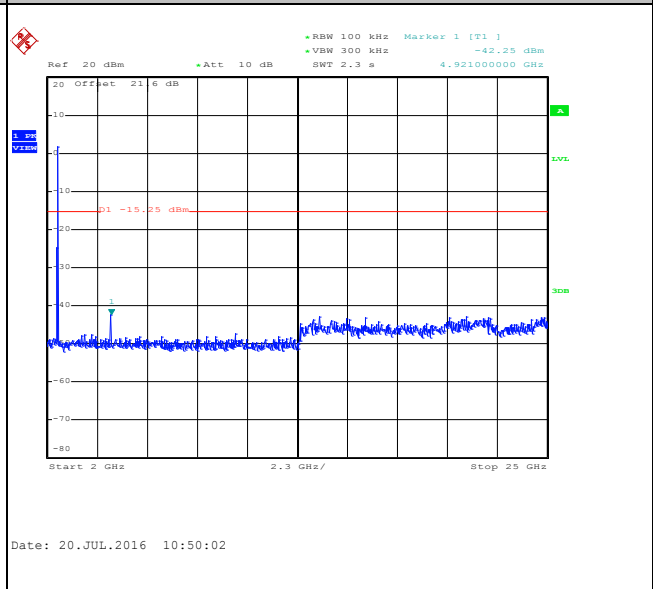





Test Mode :	802.11b	Temperature :	21~25°C
Test Band :	2.4GHz High	Relative Humidity :	51~54%
Test Channel :	13	Test Engineer :	PH Yang

WLAN 802.11b Channel 13

100kHz PSD reference Level

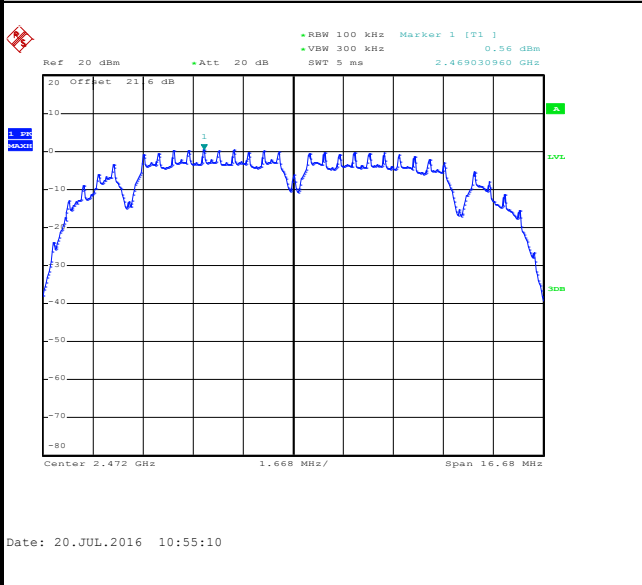

High Channel Plot

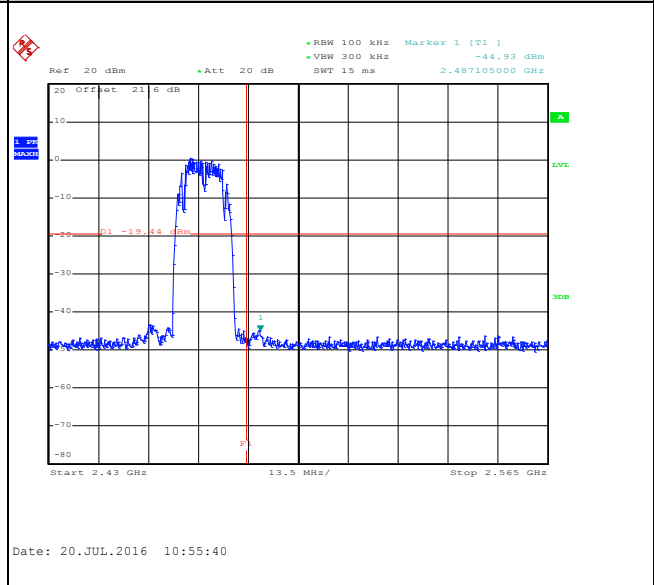

Spurious Emission 30MHz~3GHz

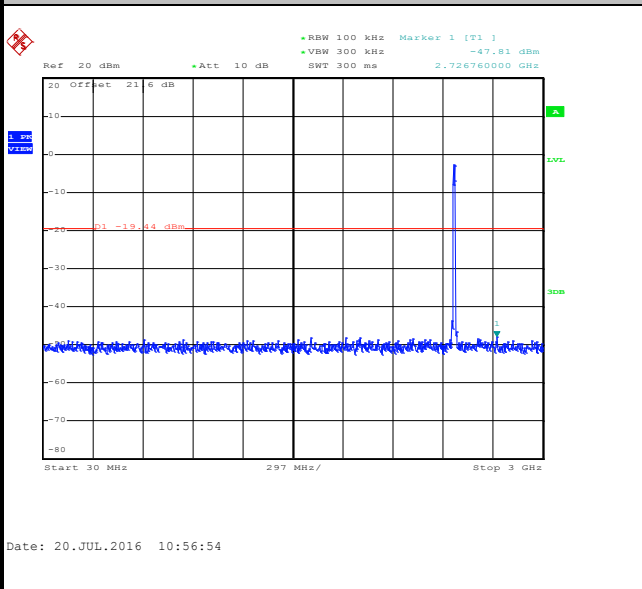

Spurious Emission 2GHz~25GHz

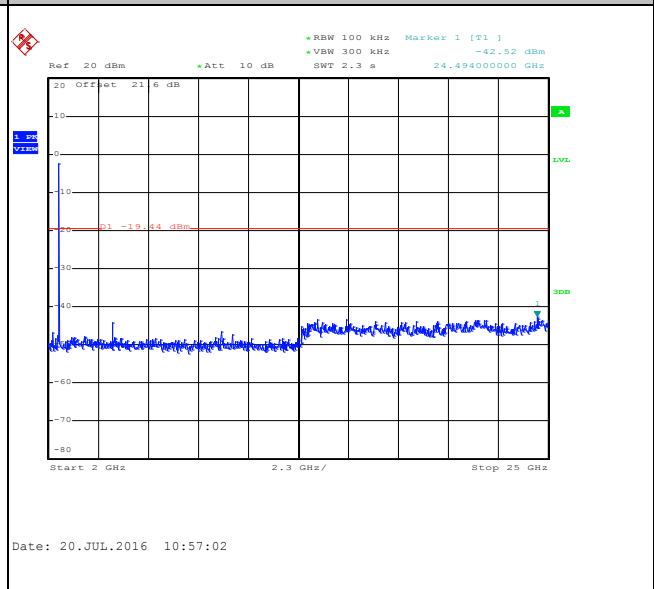



Test Mode :	802.11g	Temperature :	21~25°C
Test Band :	2.4GHz High	Relative Humidity :	51~54%
Test Channel :	12	Test Engineer :	PH Yang

WLAN 802.11g Channel 12

100kHz PSD reference Level

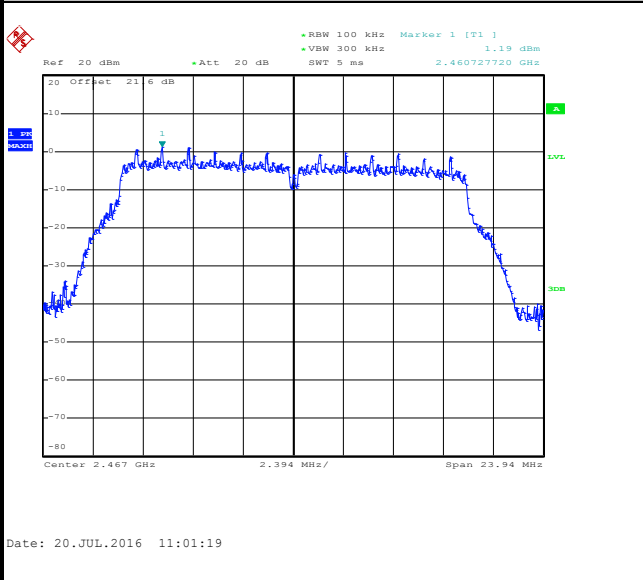

High Channel Plot

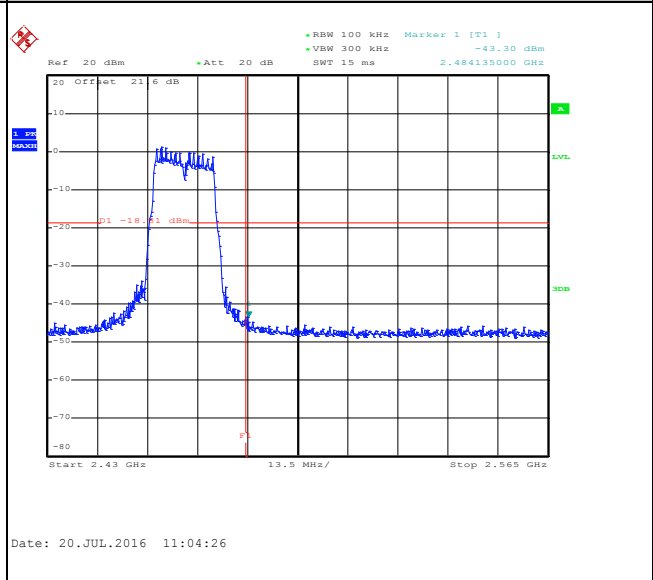

Spurious Emission 30MHz~3GHz

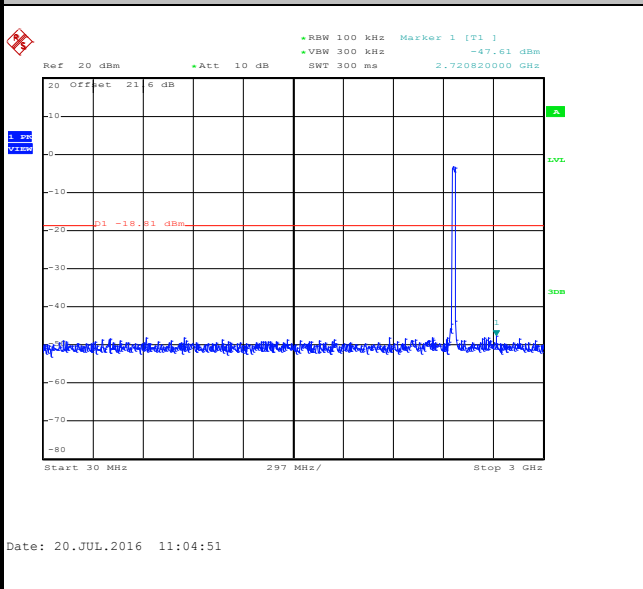

Spurious Emission 2GHz~25GHz

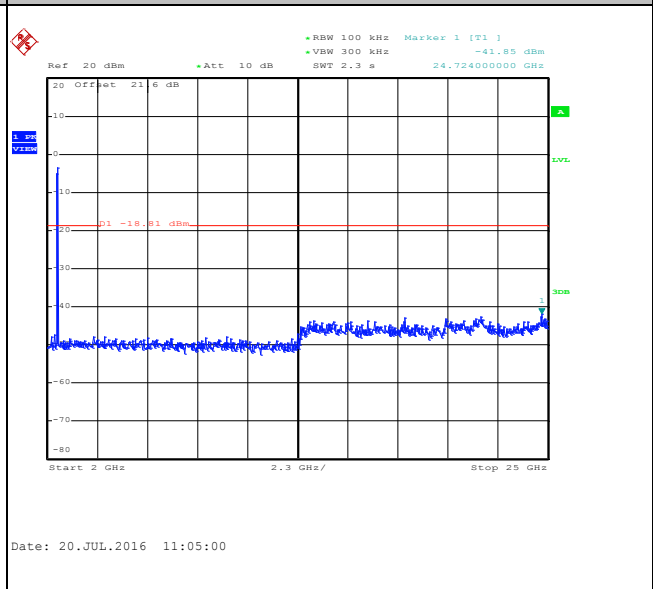



Test Mode :	802.11g	Temperature :	21~25°C
Test Band :	2.4GHz High	Relative Humidity :	51~54%
Test Channel :	13	Test Engineer :	PH Yang

WLAN 802.11g Channel 13

100kHz PSD reference Level

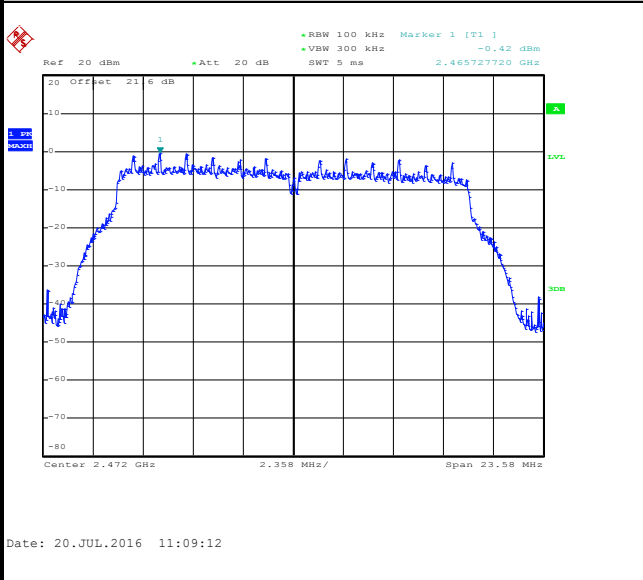

High Channel Plot

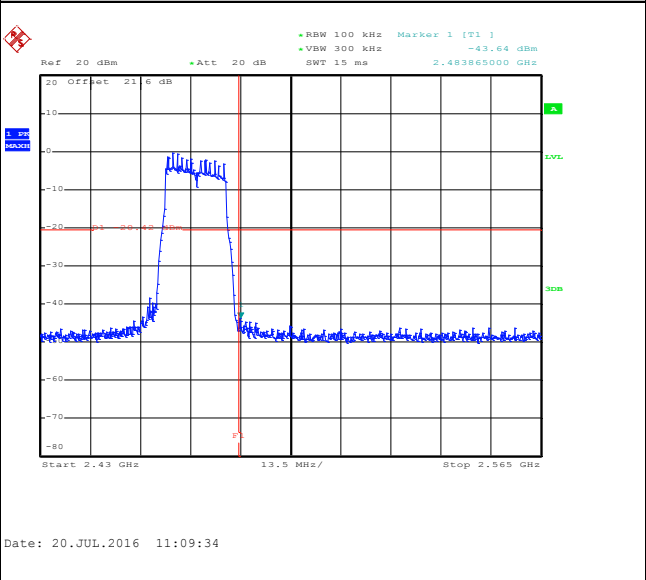

Spurious Emission 30MHz~3GHz

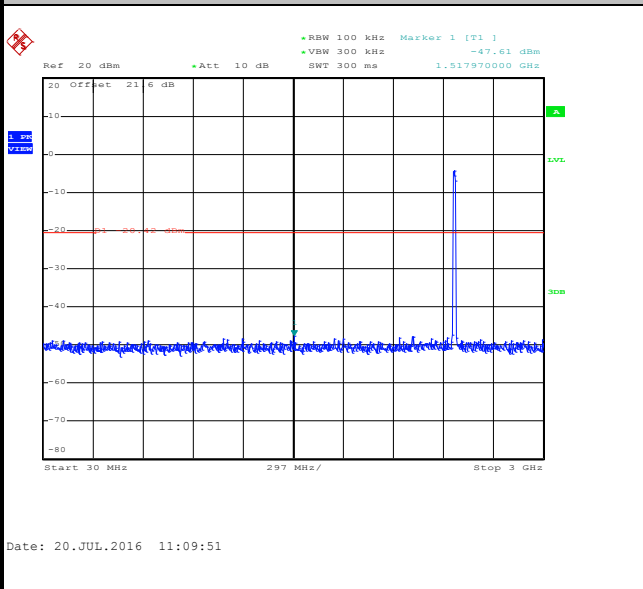

Spurious Emission 2GHz~25GHz

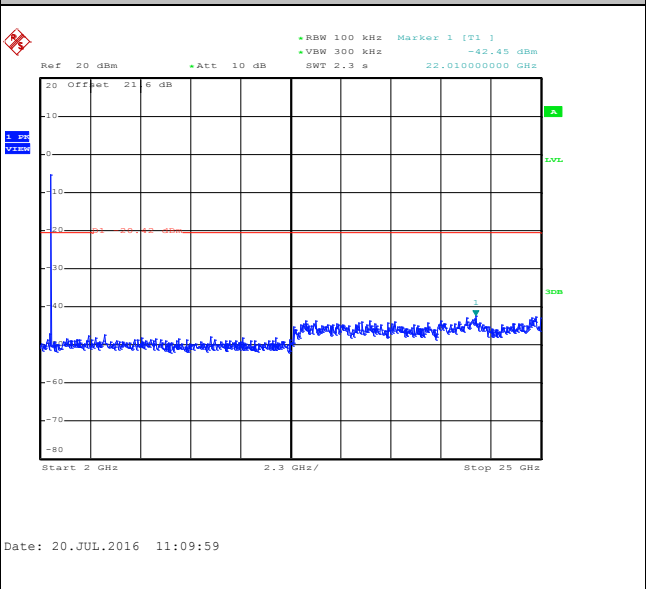



Test Mode :	802.11n HT20	Temperature :	21~25°C
Test Band :	2.4GHz High	Relative Humidity :	51~54%
Test Channel :	12	Test Engineer :	PH Yang

WLAN 802.11n HT20 Channel 12

100kHz PSD reference Level

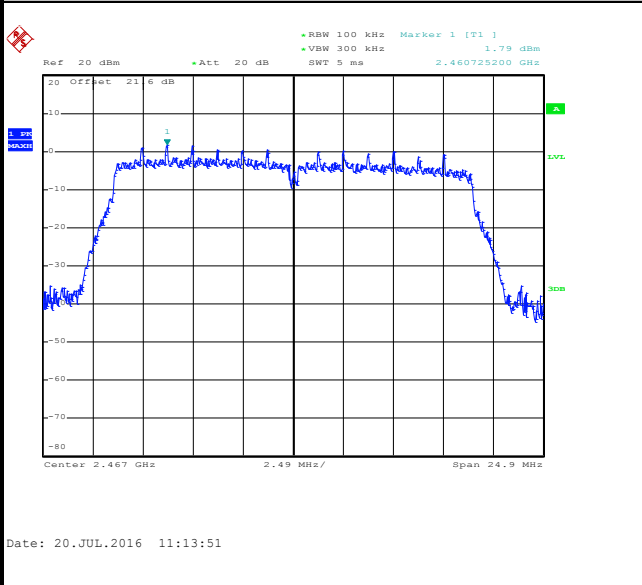

High Channel Plot

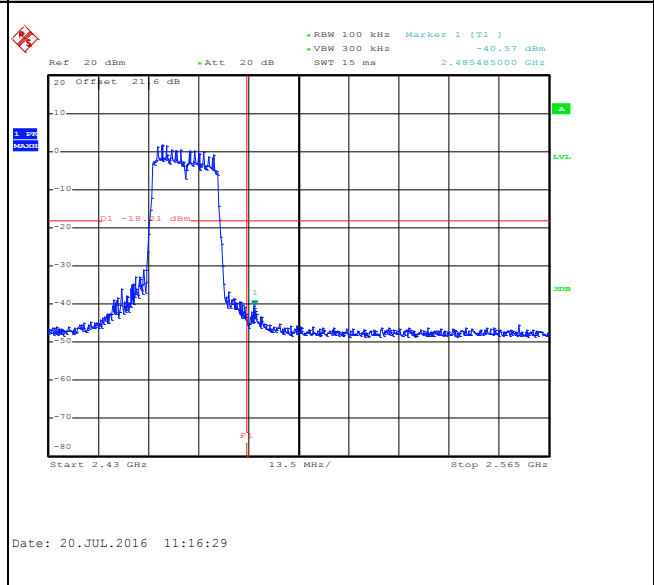

Spurious Emission 30MHz~3GHz

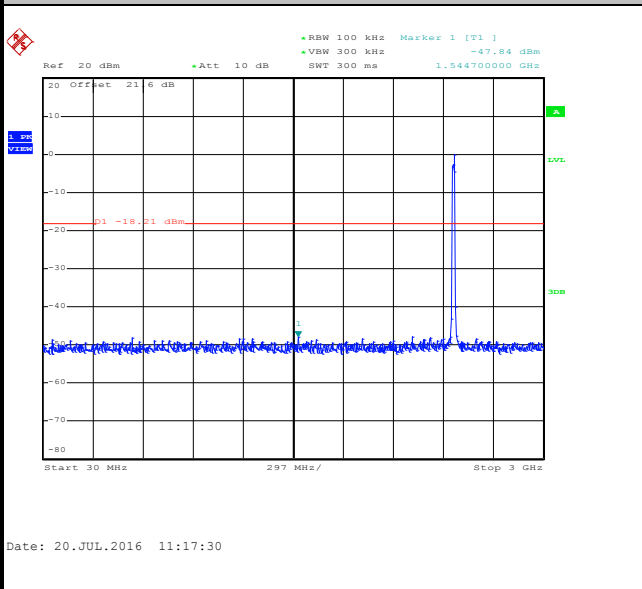

Spurious Emission 2GHz~25GHz

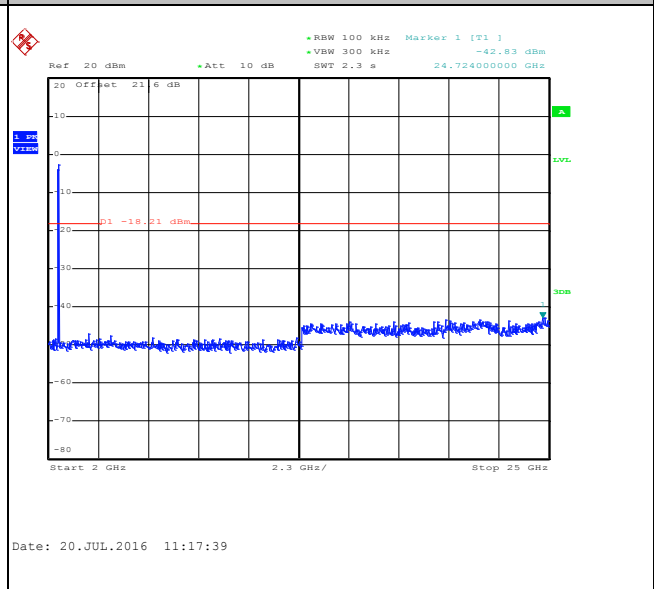



Test Mode :	802.11n HT20	Temperature :	21~25°C
Test Band :	2.4GHz High	Relative Humidity :	51~54%
Test Channel :	13	Test Engineer :	PH Yang

WLAN 802.11n HT20 Channel 13

100kHz PSD reference Level

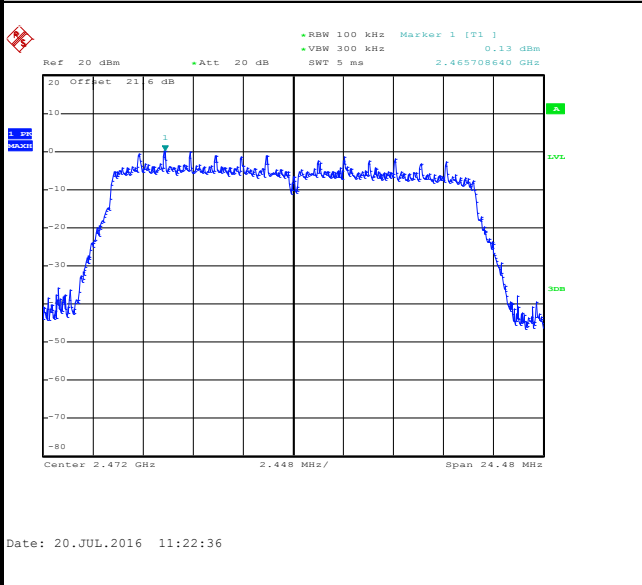

High Channel Plot

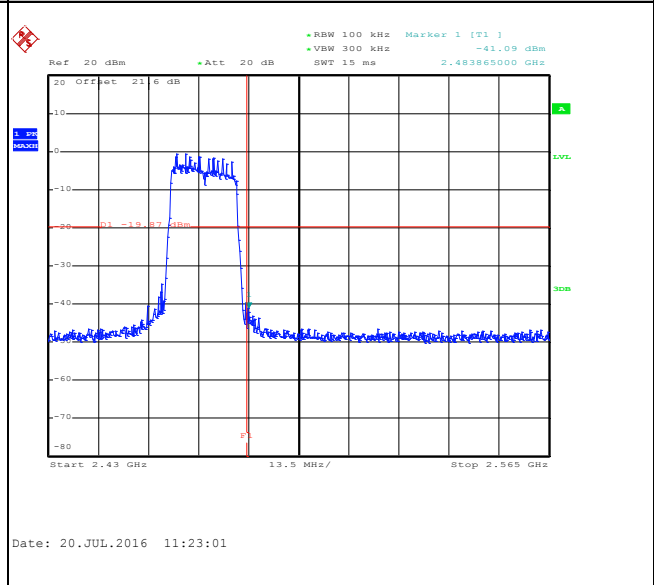

Spurious Emission 30MHz~3GHz

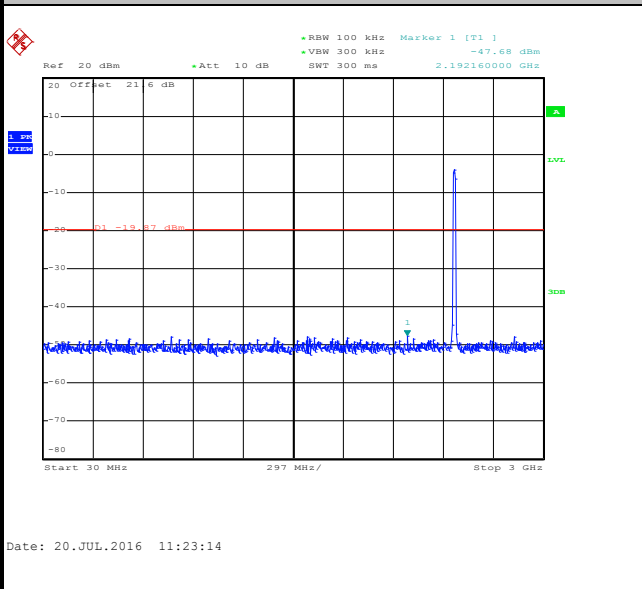

Spurious Emission 2GHz~25GHz

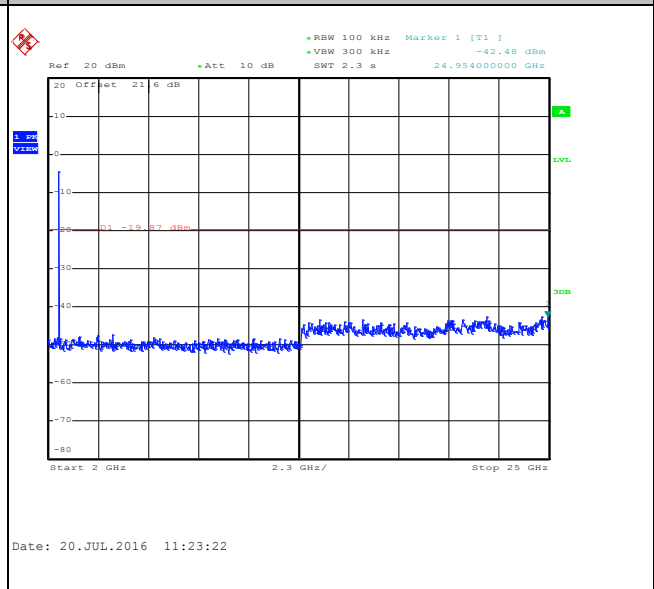



### 3.5 Radiated Band Edges and Spurious Emission Measurement

#### 3.5.1 Limit of Radiated band edge and Spurious Emission Measurement

In any 100 kHz bandwidth outside the intentional radiator frequency band, all harmonics/spurious must be at least 20 dB below the highest emission level within the authorized band. If the output power of this device was measured by spectrum analyzer, the attenuation under this paragraph shall be 30 dB instead of 20 dB. In addition, radiated emissions which fall in the restricted bands must also comply with the FCC section 15.209 limits as below.

Frequency (MHz)	Field Strength (microvolts/meter)	Measurement Distance (meters)
0.009 – 0.490	2400/F(kHz)	300
0.490 – 1.705	24000/F(kHz)	30
1.705 – 30.0	30	30
30 – 88	100	3
88 – 216	150	3
216 - 960	200	3
Above 960	500	3

#### 3.5.2 Measuring Instruments

The measuring equipment is listed in the section 4 of this test report.



### 3.5.3 Test Procedures

1. The testing follows FCC KDB Publication No. 558074 D01 DTS Meas. Guidance v03r05.
2. The EUT was arranged to its worst case and then tune the antenna tower (from 1 m to 4 m) and turntable (from 0 degree to 360 degrees) to find the maximum reading. A pre-amp and a high pass filter are used for the test in order to get better signal level.
3. The EUT was placed on a turntable with 0.8 meter for frequency below 1GHz and 1.5 meter for frequency above 1GHz respectively above ground.
4. The EUT was set 3 meters from the interference receiving antenna, which was mounted on the top of a variable height antenna tower.
5. Corrected Reading: Antenna Factor + Cable Loss + Read Level - Preamp Factor = Level
6. For measurement below 1GHz, If the emission level of the EUT measured by the peak detector is 3 dB lower than the applicable limit, the peak emission level will be reported. Otherwise, the emission measurement will be repeated using the quasi-peak detector and reported.
7. Use the following spectrum analyzer settings:
  - (1) Span shall wide enough to fully capture the emission being measured;
  - (2) Set RBW=100 kHz for  $f < 1$  GHz; VBW  $\geq$  RBW; Sweep = auto; Detector function = peak; Trace = max hold;
  - (3) Set RBW = 1 MHz, VBW= 3MHz for  $f \geq 1$  GHz for peak measurement.  
For average measurement:
    - VBW = 10 Hz, when duty cycle is no less than 98 percent.
    - VBW  $\geq 1/T$ , when duty cycle is less than 98 percent where T is the minimum transmission duration over which the transmitter is on and is transmitting at its maximum power control level for the tested mode of operation.

### 3.5.4 Test Setup

For radiated emissions below 30MHz

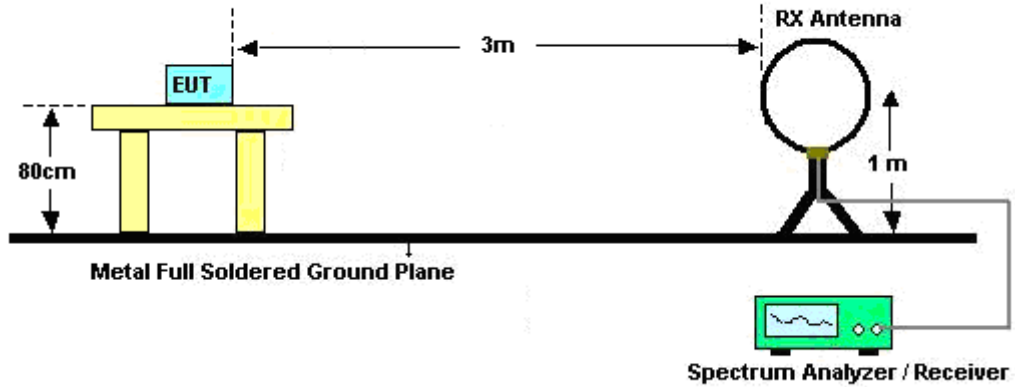

For radiated emissions from 30MHz to 1GHz

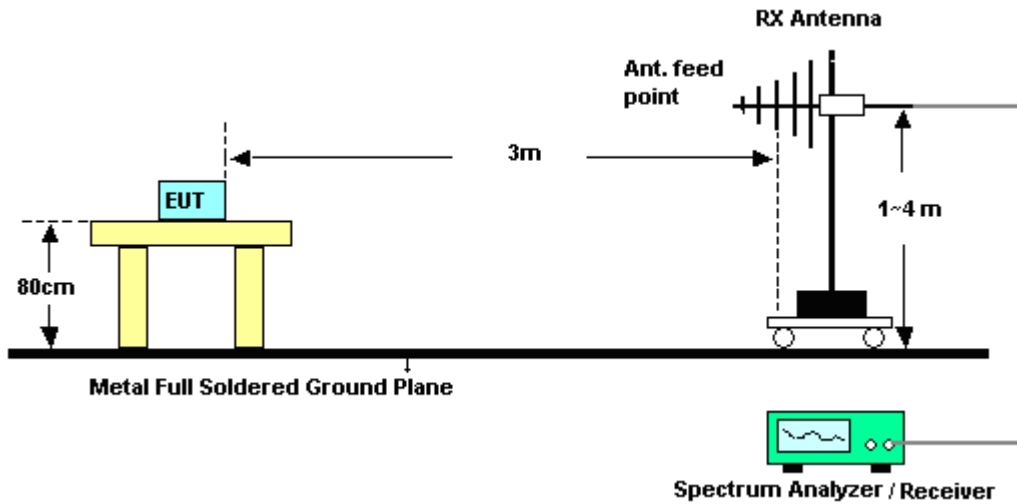



For radiated emissions above 1GHz

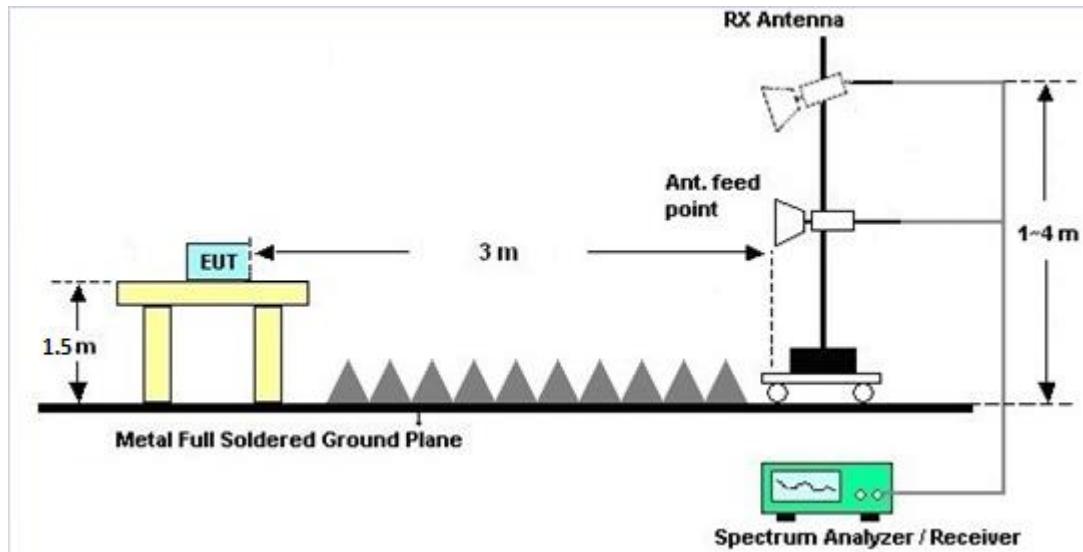

### 3.5.5 Test Results of Radiated Spurious Emissions (9kHz ~ 30MHz)

The low frequency, which started from 9 kHz to 30MHz, was pre-scanned and the result which was 20dB lower than the limit line per 15.31(o) was not reported.

### 3.5.6 Test Result of Radiated Spurious at Band Edges

Please refer to Appendix B and C.

### 3.5.7 Duty Cycle

Please refer to Appendix D.

### 3.5.8 Test Result of Radiated Spurious Emission (30MHz ~ 10<sup>th</sup> Harmonic)

Please refer to Appendix B and C.



## **3.6 Antenna Requirements**

### **3.6.1 Standard Applicable**

If directional gain of transmitting antennas is greater than 6dBi, the power shall be reduced by the same level in dB comparing to gain minus 6dBi. For the fixed point-to-point operation, the power shall be reduced by one dB for every 3 dB that the directional gain of the antenna exceeds 6 dBi. The use of a permanently attached antenna or of an antenna that uses a unique coupling to the intentional radiator shall be considered sufficient to comply with the FCC rule.

### **3.6.2 Antenna Anti-Replacement Construction**

An embedded-in antenna design is used.

### **3.6.3 Antenna Gain**

The antenna peak gain of EUT is less than 6 dBi. Therefore, it is not necessary to reduce maximum peak output power limit.



## 4 List of Measuring Equipment

Instrument	Manufacturer	Model No.	Serial No.	Characteristics	Calibration Date	Test Date	Due Date	Remark
DC Power Supply	TOPWARD	3303D	740889	N/A	May 20, 2016	Jul. 20, 2016	May 19, 2017	Conducted (TH02-HY)
Power Meter	Anritsu	ML2495A	1036004	300MHz~40G Hz	Jul. 29, 2015	Jul. 20, 2016	Jul. 28, 2016	Conducted (TH02-HY)
Power Sensor	Anritsu	MA2411B	1027253	300MHz~40G Hz	Jul. 29, 2015	Jul. 20, 2016	Jul. 28, 2016	Conducted (TH02-HY)
Spectrum Analyzer	Rohde & Schwarz	FSP40	100055	9kHz~40GHz	Jun. 17, 2016	Jul. 20, 2016	Jun. 16, 2017	Conducted (TH02-HY)
Bilog Antenna	TESEQ	CBL 6111D	35419	30MHz to 1GHz	Jan. 13, 2016	Jul.19, 2016~Jul. 20, 2016	Jan. 12, 2017	Radiation (03CH07-HY)
Double Ridge Horn Antenna	ESCO	3117	00075962	1GHz ~ 18GHz	Aug. 21, 2015	Jul.19, 2016~Jul. 20, 2016	Aug. 20, 2016	Radiation (03CH07-HY)
EMI Test Receiver	Keysight	N9038A(MXE)	MY54130085	20Hz ~ 8.4GHz	Nov. 04, 2015	Jul.19, 2016~Jul. 20, 2016	Nov. 03, 2016	Radiation (03CH07-HY)
Loop Antenna	Rohde & Schwarz	HFH2-Z2	100315	9 kHz~30 MHz	Sep. 02, 2015	Jul.19, 2016~Jul. 20, 2016	Sep. 01, 2016	Radiation (03CH07-HY)
Preamplifier	MITEQ	AMF-7D-00101800-30-10P	1590075	1GHz ~ 18GHz	Apr. 15, 2016	Jul.19, 2016~Jul. 20, 2016	Apr. 14, 2017	Radiation (03CH07-HY)
Preamplifier	COM-POWER	PA-103A	161241	10MHz-1GHz	Mar. 18, 2016	Jul.19, 2016~Jul. 20, 2016	Mar. 17, 2017	Radiation (03CH07-HY)
Preamplifier	Agilent	8449B	3008A02362	1GHz~26.5GHz	Oct. 19, 2015	Jul.19, 2016~Jul. 20, 2016	Oct. 18, 2016	Radiation (03CH07-HY)
Spectrum Analyzer	Agilent	N9010A	MY53470118	10Hz~44GHz	Feb. 27, 2016	Jul.19, 2016~Jul. 20, 2016	Feb. 26, 2017	Radiation (03CH07-HY)
Antenna Mast	Max-Full	MFA520BS	N/A	1m~4m	N/A	Jul.19, 2016~Jul. 20, 2016	N/A	Radiation (03CH07-HY)
Turn Table	ChainTek	Chaintek 3000	N/A	0~360 Degree	N/A	Jul.19, 2016~Jul. 20, 2016	N/A	Radiation (03CH07-HY)
Preamplifier	MITEQ	TTA0204	1872107	2GHz~40GHz	Feb. 15, 2015	Jul.19, 2016~Jul. 20, 2016	Feb. 14, 2017	Radiation (03CH07-HY)
SHF-EHF Horn Antenna	SCHWARZBECK	BBHA 9170	BBHA9170584	18GHz-40GHz	Nov. 02, 2015	Jul.19, 2016~Jul. 20, 2016	Nov. 01, 2016	Radiation (03CH07-HY)



## 5 Uncertainty of Evaluation

### Uncertainty of Radiated Emission Measurement (30 MHz ~ 1000 MHz)

Measuring Uncertainty for a Level of Confidence of 95% ( $U = 2Uc(y)$ )	4.50
---	------



## **Appendix A. Conducted Test Results**

**A1 - DTS Part**

Test Engineer:	PHYang	Temperature:	21~25	°C
Test Date:	2016/7/20	Relative Humidity:	51~54	%

**TEST RESULTS DATA**  
**6dB and 99% Occupied Bandwidth**

2.4GHz Band								
Mod.	Data Rate	N <sub>TX</sub>	CH.	Freq. (MHz)	99% Occupied BW (MHz)	6dB BW (MHz)	6dB BW Limit (MHz)	Pass/Fail
11b	1Mbps	1	12	2467	14.20	12.08	0.50	Pass
11b	1Mbps	1	13	2472	14.15	11.12	0.50	Pass
11g	6Mbps	1	12	2467	17.90	15.96	0.50	Pass
11g	6Mbps	1	13	2472	17.85	15.72	0.50	Pass
HT20	MCS0	1	12	2467	18.60	16.60	0.50	Pass
HT20	MCS0	1	13	2472	18.55	16.32	0.50	Pass

**TEST RESULTS DATA**  
**Peak Power Table**

2.4GHz Band										
Mod.	Data Rate	N <sub>TX</sub>	CH.	Freq. (MHz)	Peak Conducted Power (dBm)	Conducted Power Limit (dBm)	DG (dBi)	EIRP Power (dBm)	EIRP Power Limit (dBm)	Pass /Fail
11b	1Mbps	1	12	2467	17.61	30.00	1.17	18.78	36.00	Pass
11b	1Mbps	1	13	2472	13.32	30.00	1.17	14.49	36.00	Pass
11g	6Mbps	1	12	2467	21.45	30.00	1.17	22.62	36.00	Pass
11g	6Mbps	1	13	2472	20.28	30.00	1.17	21.45	36.00	Pass
HT20	MCS0	1	12	2467	21.92	30.00	1.17	23.09	36.00	Pass
HT20	MCS0	1	13	2472	20.81	30.00	1.17	21.98	36.00	Pass



**TEST RESULTS DATA**  
**Average Power Table**  
***(Reporting Only)***

2.4GHz Band						
Mod.	Data Rate	N <sub>TX</sub>	CH.	Freq. (MHz)	Duty Factor (dB)	Average Conducted Power (dBm)
11b	1Mbps	1	12	2467	0.00	14.25
11b	1Mbps	1	13	2472	0.00	10.21
11g	6Mbps	1	12	2467	0.12	11.96
11g	6Mbps	1	13	2472	0.12	10.09
HT20	MCS0	1	12	2467	0.13	12.39
HT20	MCS0	1	13	2472	0.13	10.77

**TEST RESULTS DATA**  
**Peak Power Density**

2.4GHz Band								
Mod.	Data Rate	N <sub>TX</sub>	CH.	Freq. (MHz)	Peak PSD (dBm /3kHz)	DG (dBi)	Peak PSD Limit (dBm /3kHz)	Pass/Fail
11b	1Mbps	1	12	2467	-9.67	1.17	8.00	Pass
11b	1Mbps	1	13	2472	-12.22	1.17	8.00	Pass
11g	6Mbps	1	12	2467	-11.99	1.17	8.00	Pass
11g	6Mbps	1	13	2472	-11.94	1.17	8.00	Pass
HT20	MCS0	1	12	2467	-10.98	1.17	8.00	Pass
HT20	MCS0	1	13	2472	-12.21	1.17	8.00	Pass



## Appendix B. Radiated Spurious Emission

<b>Test Engineer :</b>	Derreck Chen and James Chiu	<b>Temperature :</b>	21~23°C
		<b>Relative Humidity :</b>	60~63%



**2.4GHz 2400~2483.5MHz  
WIFI 802.11b (Band Edge @ 3m)**

WIFI	Note	Frequency	Level	Over	Limit	Read	Antenna	Cable	Preamp	Ant	Table	Peak	Pol.
Ant.				Limit	Line	Level	Factor	Loss	Factor	Pos	Pos	Avg.	
1		( MHz )	( dBμV/m )	( dB )	( dBμV/m )	( dBμV )	( dB/m )	( dB )	( dB )	( cm )	( deg )	( P/A )	( H/V )
802.11b CH 12 2467MHz	*	2467	106.73	-	-	101.42	32.11	7.4	34.2	376	158	P	H
	*	2467	103.33	-	-	98.02	32.11	7.4	34.2	376	158	A	H
		2483.88	60.01	-13.99	74	54.63	32.16	7.4	34.18	376	158	P	H
		2484.12	52.55	-1.45	54	47.17	32.16	7.4	34.18	376	158	A	H
													H
													H
	*	2467	103.98	-	-	98.67	32.11	7.4	34.2	380	146	P	V
	*	2467	100.55	-	-	95.24	32.11	7.4	34.2	380	146	A	V
		2483.8	58.97	-15.03	74	53.59	32.16	7.4	34.18	380	146	P	V
		2484.12	50.67	-3.33	54	45.29	32.16	7.4	34.18	380	146	A	V
												V	
												V	
802.11b CH 13 2472MHz	*	2472	102.47	-	-	97.11	32.16	7.4	34.2	372	158	P	H
	*	2472	99.05	-	-	93.69	32.16	7.4	34.2	372	158	A	H
		2486.2	61.3	-12.7	74	55.91	32.16	7.4	34.17	372	158	P	H
		2486.92	52.71	-1.29	54	47.32	32.16	7.4	34.17	372	158	A	H
													H
													H
	*	2472	101.24	-	-	95.88	32.16	7.4	34.2	332	135	P	V
	*	2472	97.66	-	-	92.3	32.16	7.4	34.2	332	135	A	V
		2486.92	59.04	-14.96	74	53.65	32.16	7.4	34.17	332	135	P	V
		2486.88	50.88	-3.12	54	45.49	32.16	7.4	34.17	332	135	A	V
												V	
												V	
Remark	1. No other spurious found.												
	2. All results are PASS against Peak and Average limit line.												



**2.4GHz 2400~2483.5MHz  
WIFI 802.11b (Harmonic @ 3m)**

WIFI	Note	Frequency	Level	Over	Limit	Read	Antenna	Cable	Preamp	Ant	Table	Peak	Pol.
Ant.				Limit	Line	Level	Factor	Loss	Factor	Pos	Pos	Avg.	
1		( MHz )	( dBμV/m )	( dB )	( dBμV/m )	( dBμV )	( dB/m )	( dB )	( dB )	( cm )	( deg )	( P/A )	( H/V )
802.11b CH 12 2467MHz		4934	50.09	-23.91	74	63.3	34.26	11.37	58.84	100	0	P	H
		7401	51.36	-22.64	74	59.89	35.6	13.95	58.08	100	0	P	H
													H
													H
		4934	49.67	-24.33	74	62.88	34.26	11.37	58.84	100	0	P	V
		7401	50.36	-23.64	74	58.89	35.6	13.95	58.08	100	0	P	V
													V
													V
802.11b CH 13 2472MHz		4944	46.37	-27.63	74	59.68	34.27	11.22	58.8	100	0	P	H
		7416	50.3	-23.7	74	58.83	35.6	13.95	58.08	100	0	P	H
													H
													H
		4944	46.49	-27.51	74	59.8	34.27	11.22	58.8	100	0	P	V
		7416	52.51	-21.49	74	61.04	35.6	13.95	58.08	100	0	P	V
													V
													V
<b>Remark</b>	1. No other spurious found. 2. All results are PASS against Peak and Average limit line.												



**2.4GHz 2400~2483.5MHz  
WIFI 802.11g (Band Edge @ 3m)**

WIFI	Note	Frequency	Level	Over	Limit	Read	Antenna	Cable	Preamp	Ant	Table	Peak	Pol.
Ant.				Limit	Line	Level	Factor	Loss	Factor	Pos	Pos	Avg.	
1		( MHz )	( dBμV/m )	( dB )	( dBμV/m )	( dBμV )	( dB/m )	( dB )	( dB )	( cm )	( deg )	( P/A )	( H/V )
802.11g CH 12 2467MHz	*	2467	107.09	-	-	101.78	32.11	7.4	34.2	377	159	P	H
	*	2467	99.44	-	-	94.13	32.11	7.4	34.2	377	159	A	H
		2484.44	66.51	-7.49	74	61.13	32.16	7.4	34.18	377	159	P	H
		2484.6	51.26	-2.74	54	45.88	32.16	7.4	34.18	377	159	A	H
													H
													H
	*	2467	104.02	-	-	98.71	32.11	7.4	34.2	380	147	P	V
	*	2467	96.2	-	-	90.89	32.11	7.4	34.2	380	147	A	V
		2485.84	64.71	-9.29	74	59.32	32.16	7.4	34.17	380	147	P	V
		2484.44	49.68	-4.32	54	44.3	32.16	7.4	34.18	380	147	A	V
													V
													V
802.11g CH 13 2472MHz	*	2472	105.34	-	-	99.98	32.16	7.4	34.2	376	158	P	H
	*	2472	97.3	-	-	91.94	32.16	7.4	34.2	376	158	A	H
		2485.6	67.02	-6.98	74	61.63	32.16	7.4	34.17	376	158	P	H
		2484.88	51.66	-2.34	54	46.28	32.16	7.4	34.18	376	158	A	H
													H
													H
	*	2472	102.9	-	-	97.54	32.16	7.4	34.2	380	146	P	V
	*	2472	95.1	-	-	89.74	32.16	7.4	34.2	380	146	A	V
		2483.72	69.48	-4.52	74	64.1	32.16	7.4	34.18	380	146	P	V
		2483.64	50.28	-3.72	54	44.9	32.16	7.4	34.18	380	146	A	V
													V
													V
<b>Remark</b>	1. No other spurious found. 2. All results are PASS against Peak and Average limit line.												



**2.4GHz 2400~2483.5MHz  
WIFI 802.11g (Harmonic @ 3m)**

WIFI	Note	Frequency	Level	Over	Limit	Read	Antenna	Cable	Preamp	Ant	Table	Peak	Pol.
Ant.				Limit	Line	Level	Factor	Loss	Factor	Pos	Pos	Avg.	
1		( MHz )	( dBμV/m )	( dB )	( dBμV/m )	( dBμV )	( dB/m )	( dB )	( dB )	( cm )	( deg )	( P/A )	( H/V )
802.11g CH 12 2467MHz		4934	50.68	-23.32	74	63.89	34.26	11.37	58.84	100	0	P	H
		7401	49.67	-24.33	74	58.2	35.6	13.95	58.08	100	0	P	H
													H
													H
		4934	45.36	-28.64	74	58.57	34.26	11.37	58.84	100	0	P	V
		7401	50.63	-23.37	74	59.16	35.6	13.95	58.08	100	0	P	V
													V
													V
802.11g CH 13 2472MHz		4944	45.64	-28.36	74	58.95	34.27	11.22	58.8	100	0	P	H
		7416	48.47	-25.53	74	57	35.6	13.95	58.08	100	0	P	H
													H
													H
		4944	44.83	-29.17	74	58.14	34.27	11.22	58.8	100	0	P	V
		7416	50.7	-23.3	74	59.23	35.6	13.95	58.08	100	0	P	V
													V
													V
<b>Remark</b>	1. No other spurious found. 2. All results are PASS against Peak and Average limit line.												



**2.4GHz 2400~2483.5MHz  
WIFI 802.11n HT20 (Band Edge @ 3m)**

WIFI	Note	Frequency	Level	Over	Limit	Read	Antenna	Cable	Preamp	Ant	Table	Peak	Pol.	
Ant.				Limit	Line	Level	Factor	Loss	Factor	Pos	Pos	Avg.		
1		( MHz )	( dBμV/m )	( dB )	( dBμV/m )	( dBμV )	( dB/m )	( dB )	( dB )	( cm )	( deg )	( P/A )	( H/V )	
802.11n HT20 CH 12 2467MHz	*	2467	107.44	-	-	102.13	32.11	7.4	34.2	378	158	P	H	
	*	2467	99.54	-	-	94.23	32.11	7.4	34.2	378	158	A	H	
		2485.56	71.47	-2.53	74	66.08	32.16	7.4	34.17	378	158	P	H	
		2483.52	52.44	-1.56	54	47.06	32.16	7.4	34.18	378	158	A	H	
													H	
														H
	*	2467	103.97	-	-	98.66	32.11	7.4	34.2	380	145	P	V	
	*	2467	96.54	-	-	91.23	32.11	7.4	34.2	380	145	A	V	
		2484.76	68.12	-5.88	74	62.74	32.16	7.4	34.18	380	145	P	V	
		2483.96	51.65	-2.35	54	46.27	32.16	7.4	34.18	380	145	A	V	
													V	
													V	
802.11n HT20 CH 13 2472MHz	*	2472	105.16	-	-	99.8	32.16	7.4	34.2	376	158	P	H	
	*	2472	97.62	-	-	92.26	32.16	7.4	34.2	376	158	A	H	
		2484.52	69.06	-4.94	74	63.68	32.16	7.4	34.18	376	158	P	H	
		2483.84	53.27	-0.73	54	47.89	32.16	7.4	34.18	376	158	A	H	
													H	
														H
	*	2472	104.07	-	-	98.71	32.16	7.4	34.2	380	146	P	V	
	*	2472	95.38	-	-	90.02	32.16	7.4	34.2	380	146	A	V	
		2485.92	68.64	-5.36	74	63.25	32.16	7.4	34.17	380	146	P	V	
		2483.72	51.37	-2.63	54	45.99	32.16	7.4	34.18	380	146	A	V	
													V	
													V	
<b>Remark</b>	1. No other spurious found. 2. All results are PASS against Peak and Average limit line.													





**2.4GHz 2400~2483.5MHz  
WIFI 802.11n HT20 (Harmonic @ 3m)**

WIFI	Note	Frequency	Level	Over	Limit	Read	Antenna	Cable	Preamp	Ant	Table	Peak	Pol.
Ant.				Limit	Line	Level	Factor	Loss	Factor	Pos	Pos	Avg.	
1		( MHz )	( dBμV/m )	( dB )	( dBμV/m )	( dBμV )	( dB/m )	( dB )	( dB )	( cm )	( deg )	( P/A )	( H/V )
802.11n HT20 CH 12 2467MHz		4920	49.17	-24.83	74	62.38	34.26	11.37	58.84	100	0	P	H
		7404	49.24	-24.76	74	57.77	35.6	13.95	58.08	100	0	P	H
													H
													H
		4932	45.78	-28.22	74	58.99	34.26	11.37	58.84	100	0	P	V
		7404	49.95	-24.05	74	58.48	35.6	13.95	58.08	100	0	P	V
													V
802.11n HT20 CH 13 2472MHz		4944	47.1	-26.9	74	60.41	34.27	11.22	58.8	100	0	P	H
		7422	48.56	-25.44	74	57.01	35.6	14.05	58.1	100	0	P	H
													H
													H
		4944	44.82	-29.18	74	58.13	34.27	11.22	58.8	100	0	P	V
		7416	49.96	-24.04	74	58.49	35.6	13.95	58.08	100	0	P	V
													V
Remark	1. No other spurious found.												
	2. All results are PASS against Peak and Average limit line.												



**Note symbol**

*	<b>Fundamental Frequency</b> which can be ignored. However, the level of any unwanted emissions shall not exceed the level of the fundamental frequency.
!	Test result is <b>over limit</b> line.
P/A	<b>Peak</b> or <b>Average</b>
H/V	<b>Horizontal</b> or <b>Vertical</b>



A calculation example for radiated spurious emission is shown as below:

WIFI Ant. 1	Note	Frequency ( MHz )	Level ( dBμV/m )	Over Limit ( dB )	Limit Line ( dBμV/m )	Read Level ( dBμV )	Antenna Factor ( dB/m )	Cable Loss ( dB )	Preamp Factor ( dB )	Ant Pos ( cm )	Table Pos ( deg )	Peak Avg. ( P/A )	Pol. ( H/V )
802.11b		2390	55.45	-18.55	74	54.51	32.22	4.58	35.86	103	308	P	H
CH 01		2390	43.54	-10.46	54	42.6	32.22	4.58	35.86	103	308	A	H
2412MHz													

- Level(dBμV/m) =  
Antenna Factor(dB/m) + Cable Loss(dB) + Read Level(dBμV) - Preamp Factor(dB)
- Over Limit(dB) = Level(dBμV/m) – Limit Line(dBμV/m)

**For Peak Limit @ 2390MHz:**

- Level(dBμV/m)  
= Antenna Factor(dB/m) + Cable Loss(dB) + Read Level(dBμV) - Preamp Factor(dB)  
= 32.22(dB/m) + 4.58(dB) + 54.51(dBμV) – 35.86 (dB)  
= 55.45 (dBμV/m)
- Over Limit(dB)  
= Level(dBμV/m) – Limit Line(dBμV/m)  
= 55.45(dBμV/m) – 74(dBμV/m)  
= -18.55(dB)

**For Average Limit @ 2390MHz:**

- Level(dBμV/m)  
= Antenna Factor(dB/m) + Cable Loss(dB) + Read Level(dBμV) - Preamp Factor(dB)  
= 32.22(dB/m) + 4.58(dB) + 42.6(dBμV) – 35.86 (dB)  
= 43.54 (dBμV/m)
- Over Limit(dB)  
= Level(dBμV/m) – Limit Line(dBμV/m)  
= 43.54(dBμV/m) – 54(dBμV/m)  
= -10.46(dB)

Both peak and average measured complies with the limit line, so test result is “PASS”.



## Appendix C. Radiated Spurious Emission Plots

<b>Test Engineer :</b>	Derreck Chen and James Chiu	<b>Temperature :</b>	21~23°C
		<b>Relative Humidity :</b>	60~63%

### Note symbol

-L	Low channel location
-R	High channel location



**2.4GHz 2400~2483.5MHz**  
**WIFI 802.11b (Band Edge @ 3m)**

WIFI	2.4GHz 2400~2483.5MHz Band Edge @ 3m	
ANT	802.11b CH12 2467MHz	
1	Horizontal	Fundamental
Peak	<p>Site : 03CH07-HY Condition : 15.209(PEAK) 3m HF-ANT_130829 HORIZONTAL RBW: 1000.000kHz VBW:3000.000kHz SVT:Auto Detector : Peak Project : 500723-03 Mode : 1 Setting : 6/18/-10</p>	<p>Site : 03CH07-HY Condition : 15.209(PEAK) 3m HF-ANT_130829 HORIZONTAL RBW: 1000.000kHz VBW:3000.000kHz SVT:Auto Detector : Peak Project : 500723-03 Mode : 1 Setting : 6/18/-10</p>
Avg.	<p>Site : 03CH07-HY Condition : 15.209(AVG) 3m HF-ANT_130829 HORIZONTAL RBW: 1000.000kHz VBW:0.010kHz SVT:Auto Detector : Peak Project : 500723-03 Mode : 1 Setting : 6/18/-10</p>	<p>Site : 03CH07-HY Condition : 15.209(AVG) 3m HF-ANT_130829 HORIZONTAL RBW: 1000.000kHz VBW:0.010kHz SVT:Auto Detector : Peak Project : 500723-03 Mode : 1 Setting : 6/18/-10</p>



WIFI	2.4GHz 2400~2483.5MHz Band Edge @ 3m	
ANT	802.11b CH12 2467MHz	
1	Vertical	Fundamental
Peak	<p>Site : 03CH07.HY  Condition : 15.209(PEAK) 3m HF-ANT_130829 VERTICAL  Detector : Peak  Project : 500723-03  Mode : 1  Setting : 6/18/-10</p>	<p>Site : 03CH07.HY  Condition : 15.209(PEAK) 3m HF-ANT_130829 VERTICAL  Detector : Peak  Project : 500723-03  Mode : 1  Setting : 6/18/-10</p>
Avg.	<p>Site : 03CH07.HY  Condition : 15.209(AVG) 3m HF-ANT_130829 VERTICAL  Detector : Peak  Project : 500723-03  Mode : 1  Setting : 6/18/-10</p>	<p>Site : 03CH07.HY  Condition : 15.209(AVG) 3m HF-ANT_130829 VERTICAL  Detector : Peak  Project : 500723-03  Mode : 1  Setting : 6/18/-10</p>

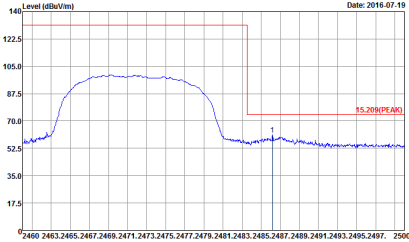
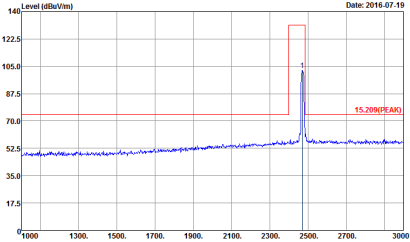
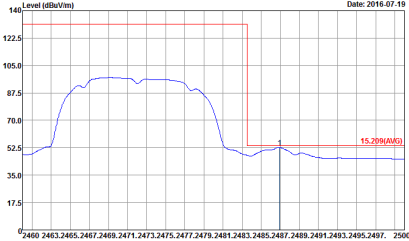
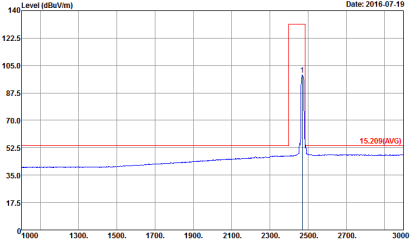

WIFI	2.4GHz 2400~2483.5MHz Band Edge @ 3m	
ANT	802.11b CH13 2472MHz	
1	Horizontal	Fundamental
Peak	 <p>Date: 2016-07-19</p> <p>Level (dBuV/m)</p> <p>Frequency (MHz)</p> <p>15.209(PEAK)</p> <p>Site : 03CH07-HY Condition : 15.209(PEAK) 3m HF-ANT_130829 HORIZONTAL REW: 1000.000kHz VBW: 3000.000kHz SWT: Auto Detector : Peak Project : 500723-03 Mode : 2 Setting : 6/18/-14</p>	 <p>Date: 2016-07-19</p> <p>Level (dBuV/m)</p> <p>Frequency (MHz)</p> <p>15.209(PEAK)</p> <p>Site : 03CH07-HY Condition : 15.209(PEAK) 3m HF-ANT_130829 HORIZONTAL REW: 1000.000kHz VBW: 3000.000kHz SWT: Auto Detector : Peak Project : 500723-03 Mode : 2 Setting : 6/18/-14</p>
Avg.	 <p>Date: 2016-07-19</p> <p>Level (dBuV/m)</p> <p>Frequency (MHz)</p> <p>15.209(AVG)</p> <p>Site : 03CH07-HY Condition : 15.209(AVG) 3m HF-ANT_130829 HORIZONTAL REW: 1000.000kHz VBW: 0.010kHz SWT: Auto Detector : Peak Project : 500723-03 Mode : 2 Setting : 6/18/-14</p>	 <p>Date: 2016-07-19</p> <p>Level (dBuV/m)</p> <p>Frequency (MHz)</p> <p>15.209(AVG)</p> <p>Site : 03CH07-HY Condition : 15.209(AVG) 3m HF-ANT_130829 HORIZONTAL REW: 1000.000kHz VBW: 0.010kHz SWT: Auto Detector : Peak Project : 500723-03 Mode : 2 Setting : 6/18/-14</p>

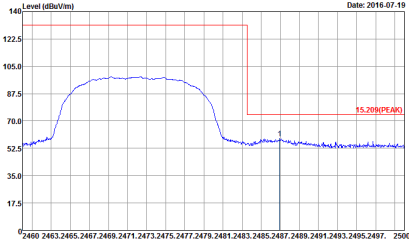
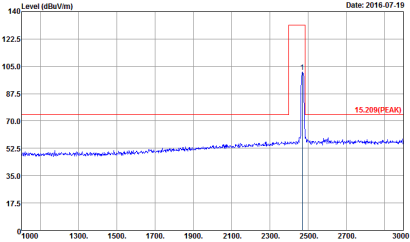
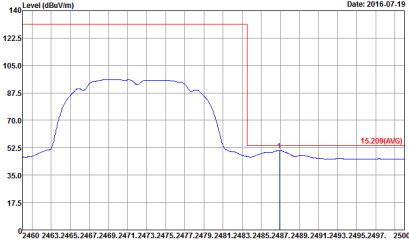
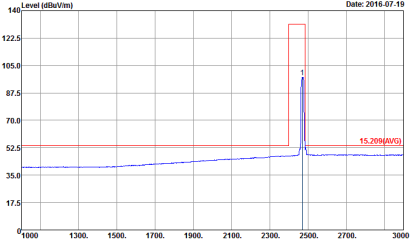

WIFI	2.4GHz 2400~2483.5MHz Band Edge @ 3m	
ANT	802.11b CH13 2472MHz	
1	Vertical	Fundamental
Peak	 <p>Site : 03CH07-HY            Condition : 15.209(PEAK) 3m HF-ANT_130829 VERTICAL            Detector : Peak            Project : 500723-03            Mode : 2            Setting : 6/18/14</p>	 <p>Site : 03CH07-HY            Condition : 15.209(PEAK) 3m HF-ANT_130829 VERTICAL            Detector : Peak            Project : 500723-03            Mode : 2            Setting : 6/18/14</p>
Avg.	 <p>Site : 03CH07-HY            Condition : 15.209(AVG) 3m HF-ANT_130829 VERTICAL            Detector : Peak            Project : 500723-03            Mode : 2            Setting : 6/18/14</p>	 <p>Site : 03CH07-HY            Condition : 15.209(AVG) 3m HF-ANT_130829 VERTICAL            Detector : Peak            Project : 500723-03            Mode : 2            Setting : 6/18/14</p>





2.4GHz 2400~2483.5MHz
WIFI 802.11g (Band Edge @ 3m)

Table with 4 columns: WIFI, ANT, Peak, Avg. and 2 main plot columns: Horizontal, Fundamental. Each plot shows Level (dBuV/m) vs Frequency (MHz) with a peak at 15.209 dBuV/m.

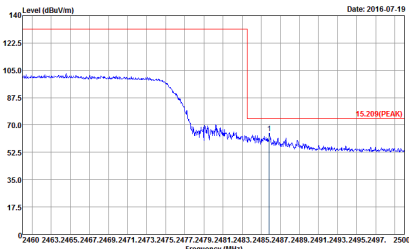
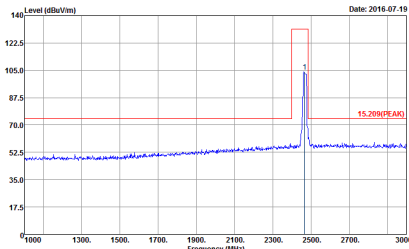
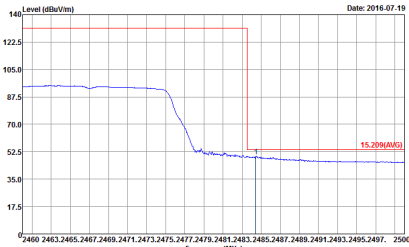
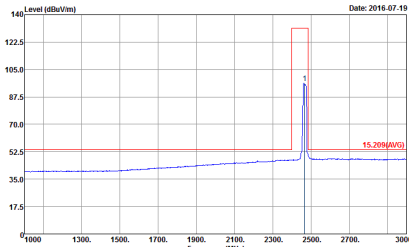

WIFI	2.4GHz 2400~2483.5MHz Band Edge @ 3m	
ANT	802.11g CH12 2467MHz	
1	Vertical	Fundamental
Peak	 <p>Site : 03CH07-HY            Condition : 15.209(PEAK) 3m HF-ANT_130829 VERTICAL            : RBW:1000.000kHz VBW:3000.000kHz SWT:Auto            Detector : Peak            Project : 500723-03            Mode : 3            Setting : 6/18/9.5</p>	 <p>Site : 03CH07-HY            Condition : 15.209(PEAK) 3m HF-ANT_130829 VERTICAL            : RBW:1000.000kHz VBW:3000.000kHz SWT:Auto            Detector : Peak            Project : 500723-03            Mode : 3            Setting : 6/18/9.5</p>
Avg.	 <p>Site : 03CH07-HY            Condition : 15.209(AVG) 3m HF-ANT_130829 VERTICAL            : RBW:1000.000kHz VBW:1.000kHz SWT:Auto            Detector : Peak            Project : 500723-03            Mode : 3            Setting : 6/18/9.5</p>	 <p>Site : 03CH07-HY            Condition : 15.209(AVG) 3m HF-ANT_130829 VERTICAL            : RBW:1000.000kHz VBW:1.000kHz SWT:Auto            Detector : Peak            Project : 500723-03            Mode : 3            Setting : 6/18/9.5</p>

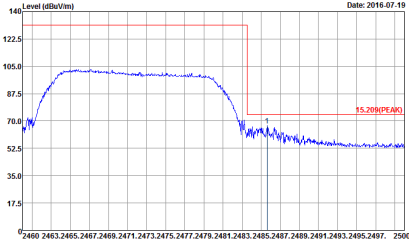
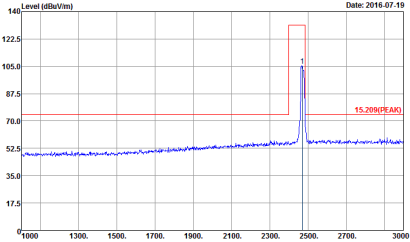
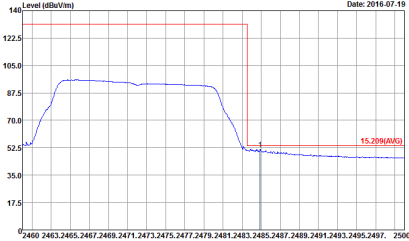
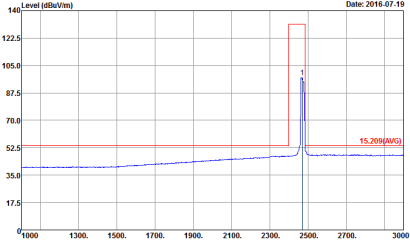

WIFI	2.4GHz 2400~2483.5MHz Band Edge @ 3m	
ANT	802.11g CH13 2472MHz	
1	Horizontal	Fundamental
Peak	 <p>Site : 03CH07-HY            Condition : 15.209(PEAK) 3m HF-ANT_130829 HORIZONTAL            Detector : Peak            Project : 500723-03            Mode : 4            Setting : 6/18/-11</p>	 <p>Site : 03CH07-HY            Condition : 15.209(PEAK) 3m HF-ANT_130829 HORIZONTAL            Detector : Peak            Project : 500723-03            Mode : 4            Setting : 6/18/-11</p>
Avg.	 <p>Site : 03CH07-HY            Condition : 15.209(AVG) 3m HF-ANT_130829 HORIZONTAL            Detector : Peak            Project : 500723-03            Mode : 4            Setting : 6/18/-11</p>	 <p>Site : 03CH07-HY            Condition : 15.209(AVG) 3m HF-ANT_130829 HORIZONTAL            Detector : Peak            Project : 500723-03            Mode : 4            Setting : 6/18/-11</p>

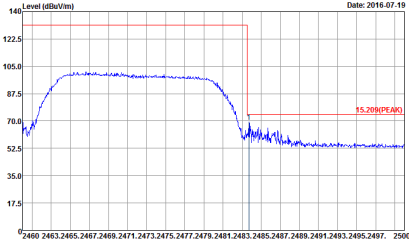
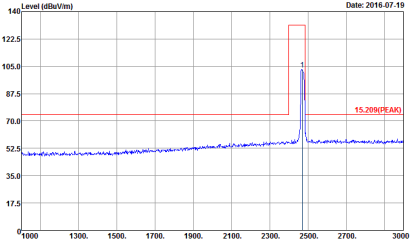
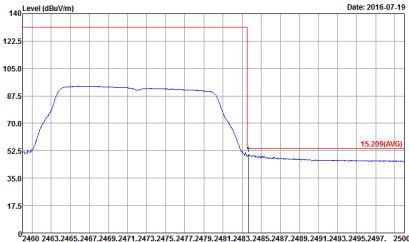
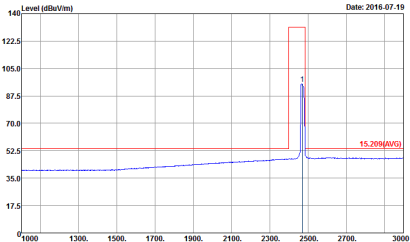

WIFI	2.4GHz 2400~2483.5MHz Band Edge @ 3m	
ANT	802.11g CH13 2472MHz	
1	Vertical	Fundamental
Peak	 <p>Site : 03CH07.HY            Condition : 15.209(PEAK) 3m HF-ANT_130829 VERTICAL            Detector : Peak            Project : 500723-03            Mode : 4            Setting : 6/18/-11</p>	 <p>Site : 03CH07.HY            Condition : 15.209(PEAK) 3m HF-ANT_130829 VERTICAL            Detector : Peak            Project : 500723-03            Mode : 4            Setting : 6/18/-11</p>
Avg.	 <p>Site : 03CH07.HY            Condition : 15.209(AVG) 3m HF-ANT_130829 VERTICAL            Detector : Peak            Project : 500723-03            Mode : 4            Setting : 6/18/-11</p>	 <p>Site : 03CH07.HY            Condition : 15.209(AVG) 3m HF-ANT_130829 VERTICAL            Detector : Peak            Project : 500723-03            Mode : 4            Setting : 6/18/-11</p>



**2.4GHz 2400~2483.5MHz**  
**WIFI 802.11n HT20 (Band Edge @ 3m)**

WIFI	2.4GHz 2400~2483.5MHz Band Edge @ 3m	
ANT	802.11n HT20 CH12 2467MHz	
1	Horizontal	Fundamental
Peak	<p>Site : 03CH07-HY            Condition : 15.209(PEAK) 3m HF-ANT_130829 HORIZONTAL            RBW: 1000.000kHz VBW:3000.000kHz SVT:Auto            Detector : Peak            Project : 500723-03            Mode : 5            Setting : 6/18/-9</p>	<p>Site : 03CH07-HY            Condition : 15.209(PEAK) 3m HF-ANT_130829 HORIZONTAL            RBW: 1000.000kHz VBW:3000.000kHz SVT:Auto            Detector : Peak            Project : 500723-03            Mode : 5            Setting : 6/18/-9</p>
Avg.	<p>Site : 03CH07-HY            Condition : 15.209(AVG) 3m HF-ANT_130829 HORIZONTAL            RBW: 1000.000kHz VBW:1.000kHz SVT:Auto            Detector : Peak            Project : 500723-03            Mode : 5            Setting : 6/18/-9</p>	<p>Site : 03CH07-HY            Condition : 15.209(AVG) 3m HF-ANT_130829 HORIZONTAL            RBW: 1000.000kHz VBW:1.000kHz SVT:Auto            Detector : Peak            Project : 500723-03            Mode : 5            Setting : 6/18/-9</p>

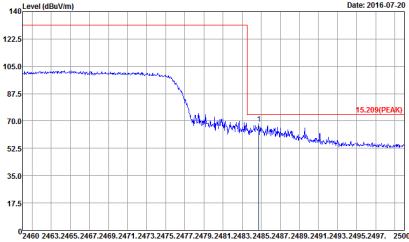
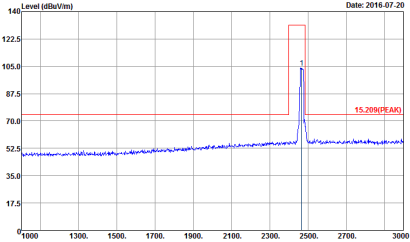
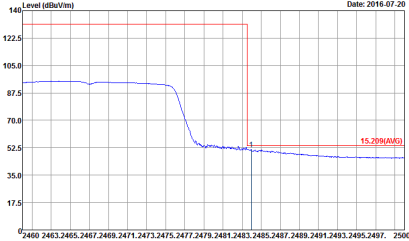
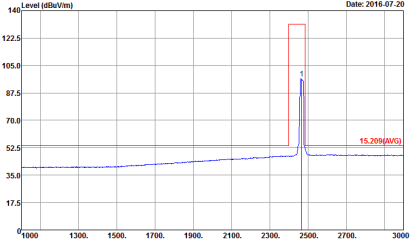

WIFI	2.4GHz 2400~2483.5MHz Fundamental @ 3m	
ANT	802.11n HT20 CH12 2467MHz	
1	Vertical	Fundamental
Peak	 <p>Date: 2016-07-20</p> <p>Level (dBuV/m)</p> <p>Frequency (MHz)</p> <p>15.209(PEAK)</p> <p>Site : 03CH07-HY Condition : 15.209(PEAK) 3m HF-ANT_130829 VERTICAL REW:1000.000kHz VBW:3000.000kHz SWT:Auto Detector : Peak Project : 500723-03 Mode : 5 Setting : 6/18/-9</p>	 <p>Date: 2016-07-20</p> <p>Level (dBuV/m)</p> <p>Frequency (MHz)</p> <p>15.209(PEAK)</p> <p>Site : 03CH07-HY Condition : 15.209(PEAK) 3m HF-ANT_130829 VERTICAL REW:1000.000kHz VBW:3000.000kHz SWT:Auto Detector : Peak Project : 500723-03 Mode : 5 Setting : 6/18/-9</p>
Avg.	 <p>Date: 2016-07-20</p> <p>Level (dBuV/m)</p> <p>Frequency (MHz)</p> <p>15.209(AVG)</p> <p>Site : 03CH07-HY Condition : 15.209(AVG) 3m HF-ANT_130829 VERTICAL REW:1000.000kHz VBW:1.000kHz SWT:Auto Detector : Peak Project : 500723-03 Mode : 5 Setting : 6/18/-9</p>	 <p>Date: 2016-07-20</p> <p>Level (dBuV/m)</p> <p>Frequency (MHz)</p> <p>15.209(AVG)</p> <p>Site : 03CH07-HY Condition : 15.209(AVG) 3m HF-ANT_130829 VERTICAL REW:1000.000kHz VBW:1.000kHz SWT:Auto Detector : Peak Project : 500723-03 Mode : 5 Setting : 6/18/-9</p>

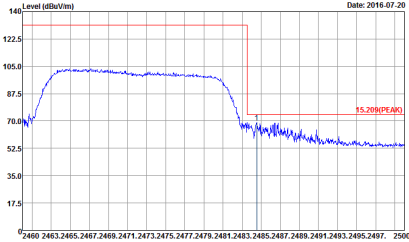
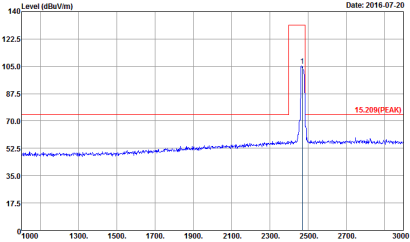
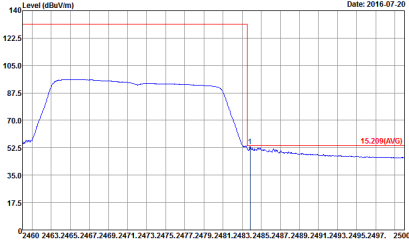
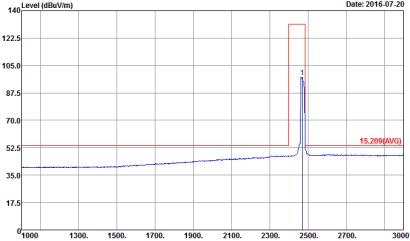

WIFI	2.4GHz 2400~2483.5MHz Band Edge @ 3m	
ANT	802.11n HT20 CH13 2472MHz	
1	Horizontal	Fundamental
Peak	 <p>Site : 03CH07.HY            Condition : 15.209(PEAK) 3m HF-ANT_130829 HORIZONTAL            : RBW:1000.000kHz VBW:3000.000kHz SWT:Auto            Detector : Peak            Project : 500723-03            Mode : S            Setting : 6/18/-10.5</p>	 <p>Site : 03CH07.HY            Condition : 15.209(PEAK) 3m HF-ANT_130829 HORIZONTAL            : RBW:1000.000kHz VBW:3000.000kHz SWT:Auto            Detector : Peak            Project : 500723-03            Mode : S            Setting : 6/18/-10.5</p>
Avg.	 <p>Site : 03CH07.HY            Condition : 15.209(AVG) 3m HF-ANT_130829 HORIZONTAL            : RBW:1000.000kHz VBW:1.000kHz SWT:Auto            Detector : Peak            Project : 500723-03            Mode : S            Setting : 6/18/-10.5</p>	 <p>Site : 03CH07.HY            Condition : 15.209(AVG) 3m HF-ANT_130829 HORIZONTAL            : RBW:1000.000kHz VBW:1.000kHz SWT:Auto            Detector : Peak            Project : 500723-03            Mode : S            Setting : 6/18/-10.5</p>

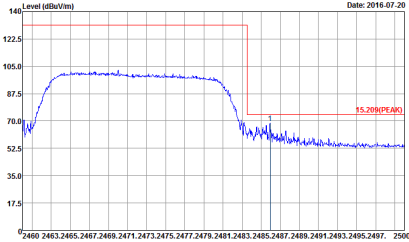
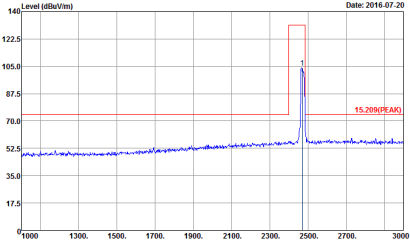
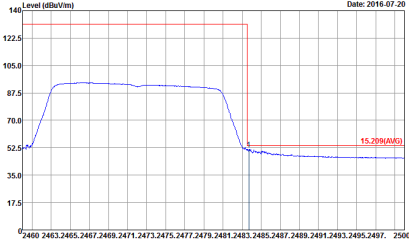
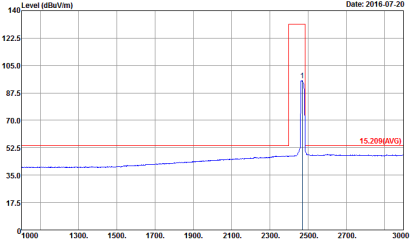

WIFI	2.4GHz 2400~2483.5MHz Fundamental @ 3m	
ANT	802.11n HT20 CH13 2472MHz	
1	Vertical	Fundamental
Peak	 <p>Site : 03CH07.HY            Condition : 15.209(PEAK) 3m HF-ANT_130829 VERTICAL            Detector : Peak            Project : 500723-03            Mode : 6            Setting : 6/18/-10.5</p>	 <p>Site : 03CH07.HY            Condition : 15.209(PEAK) 3m HF-ANT_130829 VERTICAL            Detector : Peak            Project : 500723-03            Mode : 6            Setting : 6/18/-10.5</p>
Avg.	 <p>Site : 03CH07.HY            Condition : 15.209(AVG) 3m HF-ANT_130829 VERTICAL            Detector : Peak            Project : 500723-03            Mode : 6            Setting : 6/18/-10.5</p>	 <p>Site : 03CH07.HY            Condition : 15.209(AVG) 3m HF-ANT_130829 VERTICAL            Detector : Peak            Project : 500723-03            Mode : 6            Setting : 6/18/-10.5</p>





**2.4GHz 2400~2483.5MHz  
WIFI 802.11b (Harmonic @ 3m)**

WIFI	2.4GHz 2400~2483.5MHz Harmonic @ 3m	
ANT	802.11b CH12 2467MHz	
1	Horizontal	Vertical
<p><b>Peak</b> <b>Avg.</b></p>	<p>Site : 03CH07-HY Condition : 15.209(PEAK) 3m SHF-EHF_131029 HORIZONTAL Detector : Peak Project : 500723-03 Mode : 1 Setting : 0/18/-10</p>	<p>Site : 03CH07-HY Condition : 15.209(PEAK) 3m SHF-EHF_131029 VERTICAL Detector : Peak Project : 500723-03 Mode : 1 Setting : 0/18/-10</p>



WIFI	2.4GHz 2400~2483.5MHz Harmonic @ 3m	
ANT	802.11b CH13 2472MHz	
1	Horizontal	Vertical
Peak Avg.	<p>Site : 03CH07.HY Condition : 15.209(PEAK) 3m SHF.EHF_131029 HORIZONTAL Detector : Peak Project : 500723-03 Mode : 2 Setting : 6/18/14</p>	<p>Site : 03CH07.HY Condition : 15.209(PEAK) 3m SHF.EHF_131029 VERTICAL Detector : Peak Project : 500723-03 Mode : 2 Setting : 6/18/14</p>



2.4GHz 2400~2483.5MHz
WIFI 802.11g (Harmonic @ 3m)

Table with 3 columns: WIFI (2.4GHz 2400~2483.5MHz Harmonic @ 3m), ANT (802.11g CH12 2467MHz), and Antenna Type (1). It contains two graphs: Horizontal and Vertical, both showing Peak and Avg. levels in dBuV/m across a frequency range of 0 to 25000 MHz. The graphs show a significant peak at approximately 2467 MHz.

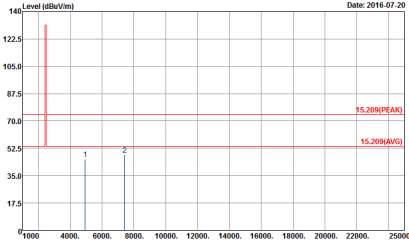
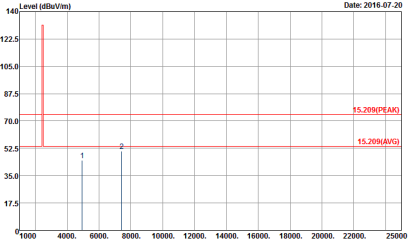

WIFI	2.4GHz 2400~2483.5MHz Harmonic @ 3m	
ANT	802.11g CH13 2472MHz	
1	Horizontal	Vertical
Peak Avg.	 <p>Date: 2016.07.20</p> <p>Site : 03CH07.HY Condition : 15.209(PEAK) 3m SHF.EHF_131029 HORIZONTAL Detector : Peak Project : 500723-03 Mode : 4 Setting : 6/18/11</p>	 <p>Date: 2016.07.20</p> <p>Site : 03CH07.HY Condition : 15.209(PEAK) 3m SHF.EHF_131029 VERTICAL Detector : Peak Project : 500723-03 Mode : 4 Setting : 6/18/11</p>



2.4GHz 2400~2483.5MHz

WIFI 802.11n HT20 (Harmonic @ 3m)

WIFI	2.4GHz 2400~2483.5MHz Harmonic @ 3m	
ANT	802.11n HT20 CH12 2467MHz	
1	Horizontal	Vertical
Peak Avg.	<p>Site : 03CH07-HY Condition : 15.209(PEAK) 3m SHF-EHF_131029 HORIZONTAL Detector : Peak Project : 500723-03 Mode : S Setting : 018/9</p>	<p>Site : 03CH07-HY Condition : 15.209(PEAK) 3m SHF-EHF_131029 VERTICAL Detector : Peak Project : 500723-03 Mode : S Setting : 018/9</p>



WIFI	2.4GHz 2400~2483.5MHz Harmonic @ 3m	
ANT	802.11n HT20 CH13 2472MHz	
1	Horizontal	Vertical
Peak Avg.	<p>Site : 03CH07-HY Condition : 15.209(PEAK) 3m SHF-EHF_131029 HORIZONTAL Detector : Peak Project : 500723-03 Mode : F Setting : 6/18/10.5</p>	<p>Site : 03CH07-HY Condition : 15.209(PEAK) 3m SHF-EHF_131029 VERTICAL Detector : Peak Project : 500723-03 Mode : F Setting : 6/18/10.5</p>



## Appendix D. Duty Cycle Plots

Antenna	Band	Duty Cycle(%)	T(us)	1/T(kHz)	VBW Setting
1	802.11b	100.00	-	-	10Hz
1	802.11g	97.22	1400	0.71	1kHz
1	2.4GHz 802.11n HT20	97.02	0.77	1kHz	

### 802.11b

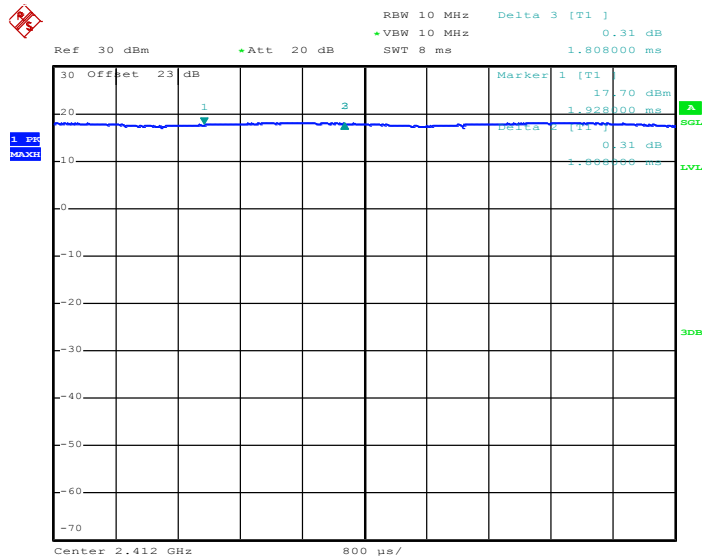

Date: 11.DEC.2015 14:34:04



802.11g

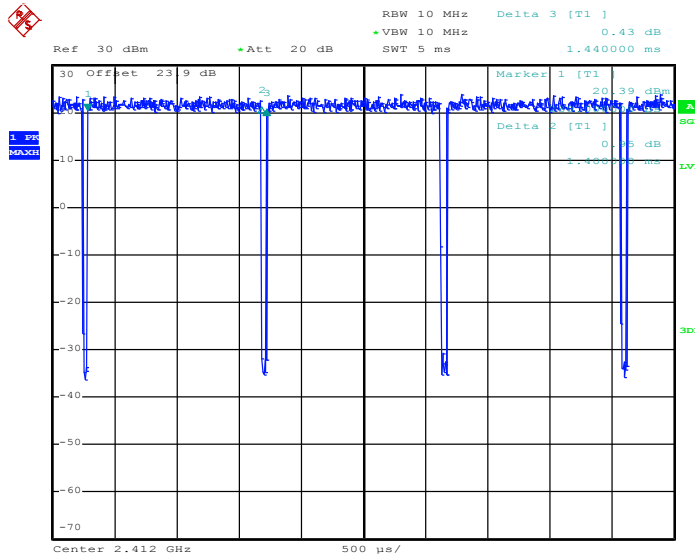

Date: 11.DEC.2015 11:09:46

802.11n HT20

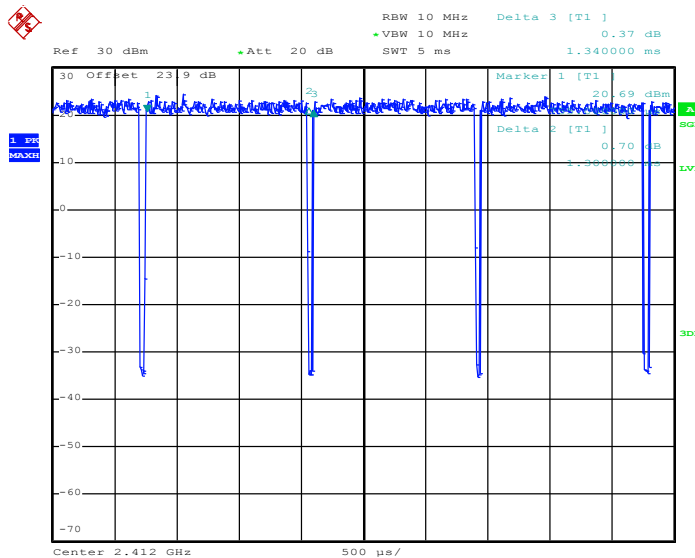

Date: 11.DEC.2015 11:19:10