

4

3

2

1

REV	ECO/PNR #	CHANGE DESCRIPTION	MARKERS	PG/LOCATION	LEAD	DATE

ITEM	PART NUMBER	TITLE	MANUFACTURER	MFG PN	QTY	ALT QTY
1	150500-000005	STRATUS ESG TRANSPONDER	APPAREO SYSTEMS	150500-000005	1	
2	353090-000028	Label, Serial Number, Stratus ESG	APPAREO SYSTEMS	353090-000028	1	
3	353090-000029	Label, Certification, Stratus ESG	APPAREO SYSTEMS	353090-000029	1	

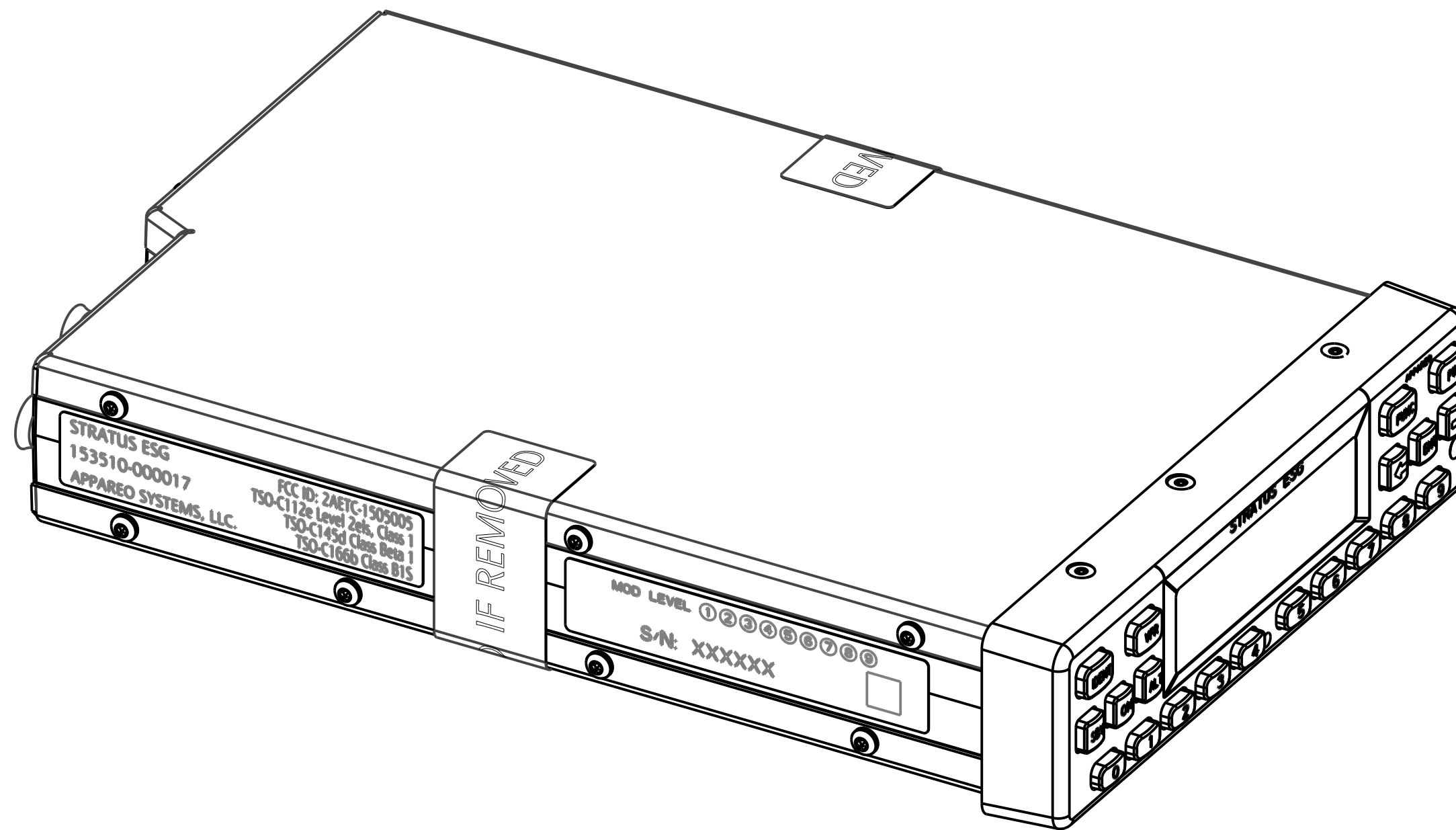

<b>APPAREO SYSTEMS PROPRIETARY</b>		THIS DOCUMENT AND THE INFORMATION CONTAINED HEREIN ARE THE PROPERTY OF APPAREO SYSTEMS, LLC AND ARE CONFIDENTIAL. THEY MAY NOT BE DISSEMINATED OR REDISTRIBUTED WITHOUT THE WRITTEN PERMISSION OF APPAREO SYSTEMS, LLC.	
TITLE: <b>Transponder, Stratus ESG</b>			
PART #: 153510-000017		PART REV: X02	
DWG UNITS: mm	SCALE: 1.000	DWG SIZE: C	SHEET #: 1 OF 1

\*Note: THE MANUFACTURERS AND THEIR PART NUMBERS CONTAINED IN THIS DOCUMENT MAY BE A PARTIAL LIST. A COMPLETE LIST OF ALL ENGINEERING REVIEWED AND APPROVED PARTS CAN BE FOUND IN EPICOR.

4

3

2

1