

Test Mode:	Bluetooth Mode
-------------------	-----------------------

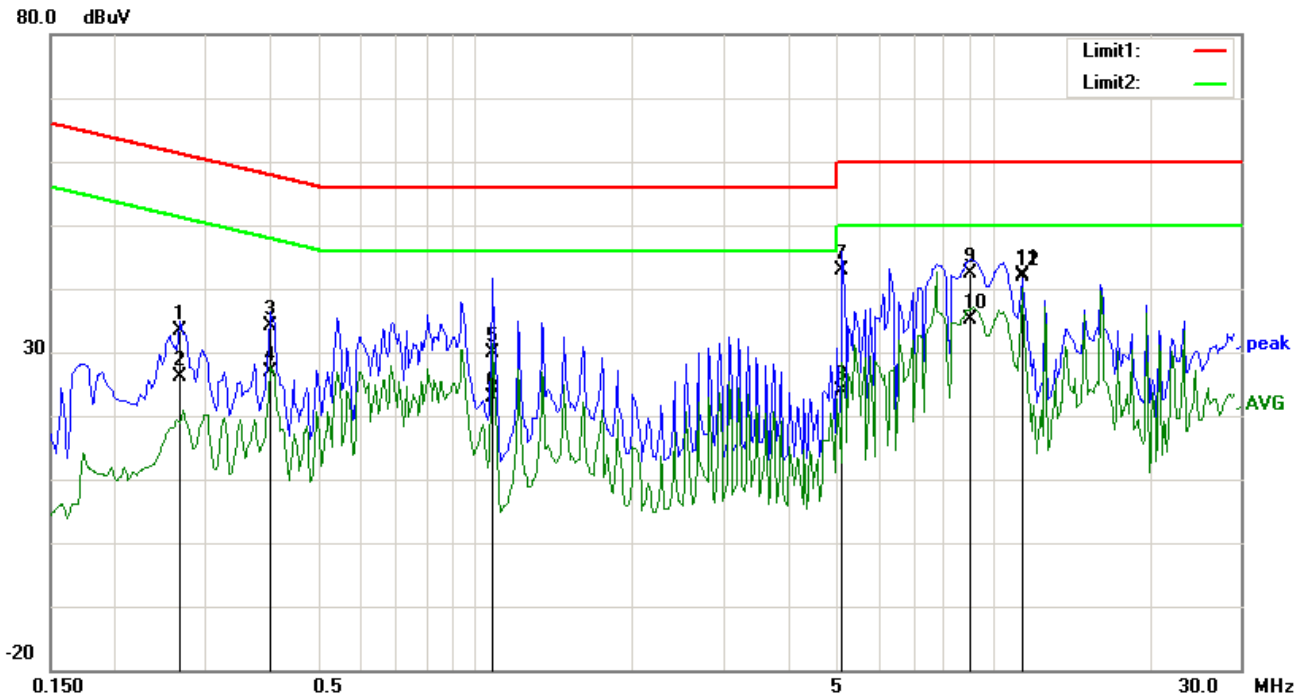

Test Data

Phase Line Plot at 240Vac, 60Hz

No.	P/L	Frequency	Reading	Detector	Corrected	Result	Limit	Margin
		(MHz)	(dBuV)		(dB)	(dBuV)	(dBuV)	(dB)
1	L1	0.2670	23.38	QP	10.03	33.41	61.21	-27.80
2	L1	0.2670	16.11	AVG	10.03	26.14	51.21	-25.07
3	L1	0.3996	23.99	QP	10.03	34.02	57.86	-23.84
4	L1	0.3996	16.95	AVG	10.03	26.98	47.86	-20.88
5	L1	1.0743	19.89	QP	10.03	29.92	56.00	-26.08
6	L1	1.0743	12.86	AVG	10.03	22.89	46.00	-23.11
7	L1	5.0982	32.83	QP	10.08	42.91	60.00	-17.09
8	L1	5.0982	13.80	AVG	10.08	23.88	50.00	-26.12
9	L1	8.9904	32.27	QP	10.14	42.41	60.00	-17.59
10	L1	8.9904	25.11	AVG	10.14	35.25	50.00	-14.75
11	L1	11.3460	31.84	QP	10.17	42.01	60.00	-17.99
12	L1	11.3460	31.68	AVG	10.17	41.85	50.00	-8.15

Test Mode:	Bluetooth Mode
-------------------	-----------------------

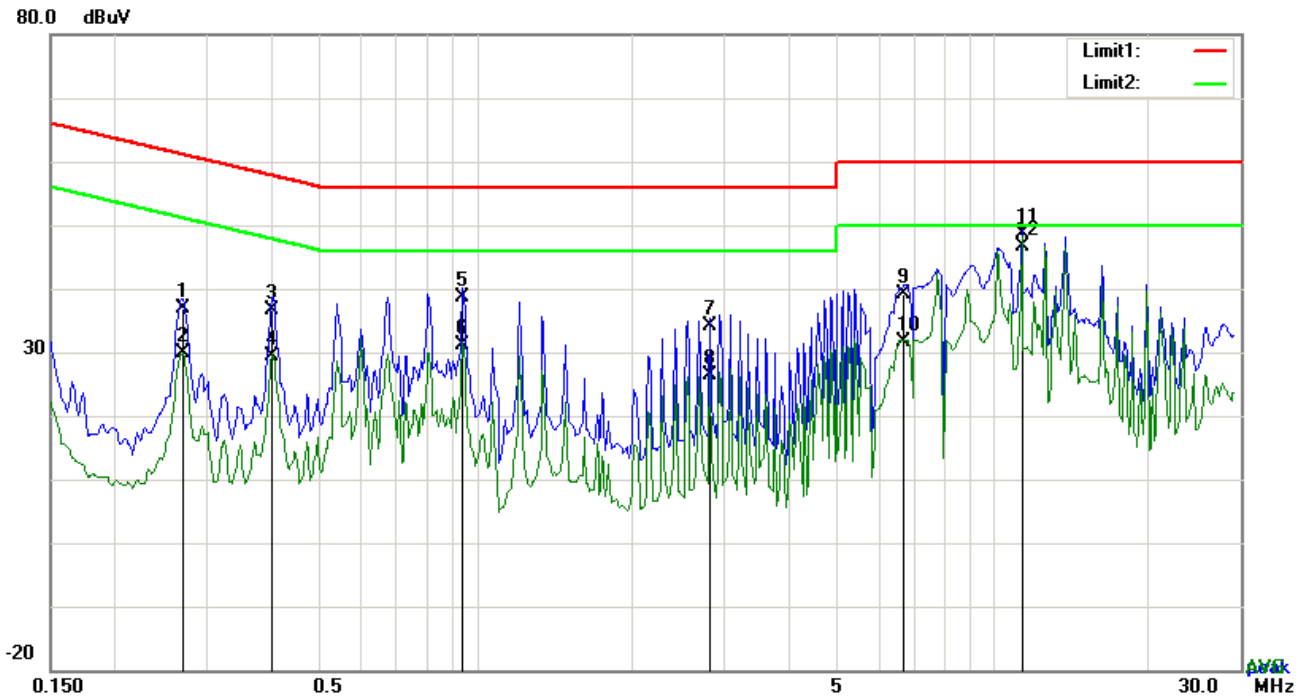

Test Data

Phase Neutral Plot at 240Vac, 60Hz

No.	P/L	Frequency	Reading	Detector	Corrected	Result	Limit	Margin
		(MHz)	(dBuV)		(dB)	(dBuV)	(dBuV)	(dB)
1	N	0.2709	26.89	QP	10.02	36.91	61.09	-24.18
2	N	0.2709	19.74	AVG	10.02	29.76	51.09	-21.33
3	N	0.4035	26.70	QP	10.02	36.72	57.78	-21.06
4	N	0.4035	19.39	AVG	10.02	29.41	47.78	-18.37
5	N	0.9417	28.52	QP	10.03	38.55	56.00	-17.45
6	N	0.9417	21.14	AVG	10.03	31.17	46.00	-14.83
7	N	2.8254	24.01	QP	10.05	34.06	56.00	-21.94
8	N	2.8254	16.40	AVG	10.05	26.45	46.00	-19.55
9	N	6.7284	29.07	QP	10.09	39.16	60.00	-20.84
10	N	6.7284	21.54	AVG	10.09	31.63	50.00	-18.37
11	N	11.3616	38.51	QP	10.16	48.67	60.00	-11.33
12	N	11.3616	36.55	AVG	10.16	46.71	50.00	-3.29

6.9 Radiated Emissions & Restricted Band

Temperature	24°C
Relative Humidity	55%
Atmospheric Pressure	1015mbar
Test date :	May 05, 2018
Tested By :	Aaron Liang

Requirement(s):

Spec	Item	Requirement	Applicable																
47CFR§15.205, §15.209, §15.247(d)	a)	Except higher limit as specified elsewhere in other section, the emissions from the low-power radio-frequency devices shall not exceed the field strength levels specified in the following table and the level of any unwanted emissions shall not exceed the level of the fundamental emission. The tighter limit applies at the band edges	<input checked="" type="checkbox"/>																
		<table border="1" style="width: 100%;"> <thead> <tr> <th>Frequency range (MHz)</th> <th>Field Strength ($\mu\text{V}/\text{m}$)</th> </tr> </thead> <tbody> <tr> <td>0.009~0.490</td> <td>2400/F(KHz)</td> </tr> <tr> <td>0.490~1.705</td> <td>24000/F(KHz)</td> </tr> <tr> <td>1.705~30.0</td> <td>30</td> </tr> <tr> <td>30 – 88</td> <td>100</td> </tr> <tr> <td>88 – 216</td> <td>150</td> </tr> <tr> <td>216 960</td> <td>200</td> </tr> <tr> <td>Above 960</td> <td>500</td> </tr> </tbody> </table>		Frequency range (MHz)	Field Strength ($\mu\text{V}/\text{m}$)	0.009~0.490	2400/F(KHz)	0.490~1.705	24000/F(KHz)	1.705~30.0	30	30 – 88	100	88 – 216	150	216 960	200	Above 960	500
		Frequency range (MHz)		Field Strength ($\mu\text{V}/\text{m}$)															
		0.009~0.490		2400/F(KHz)															
		0.490~1.705		24000/F(KHz)															
		1.705~30.0		30															
		30 – 88		100															
		88 – 216		150															
216 960	200																		
Above 960	500																		

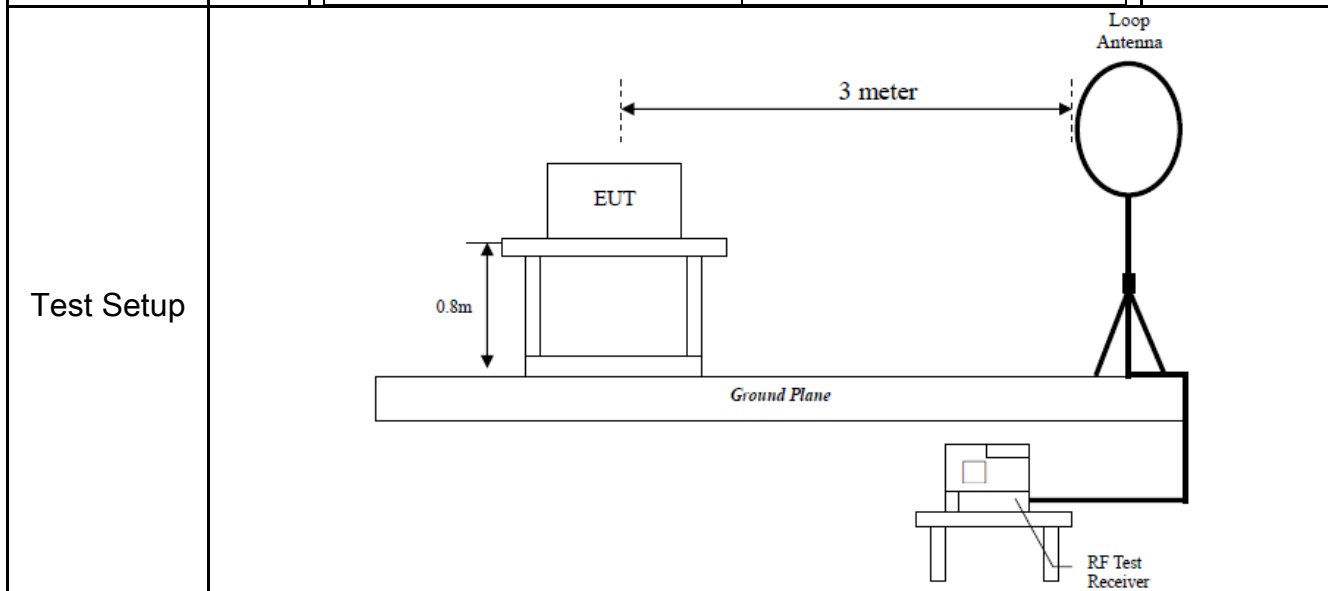

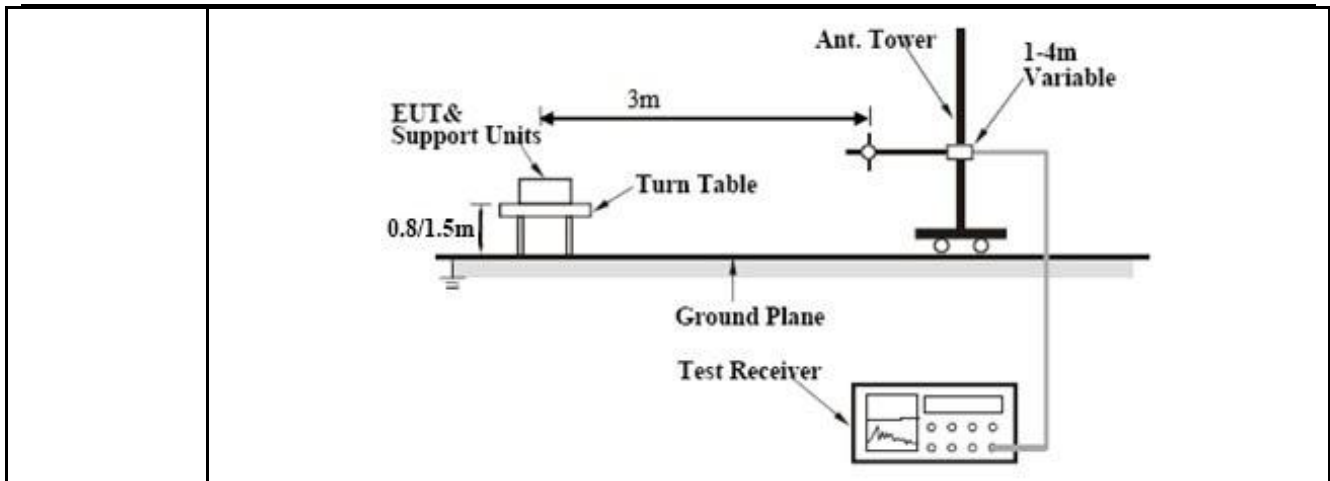

Procedure

- The EUT was switched on and allowed to warm up to its normal operating condition.
- The test was carried out at the selected frequency points obtained from the EUT characterization. Maximization of the emissions, was carried out by rotating the EUT, changing the antenna polarization, and adjusting the antenna height in the following manner:
 - Vertical or horizontal polarization (whichever gave the higher emission level over a full rotation of the EUT) was chosen.
 - The EUT was then rotated to the direction that gave the maximum emission.
 - Finally, the antenna height was adjusted to the height that gave the maximum emission.
- The resolution bandwidth and video bandwidth of test receiver/spectrum analyzer is 120 kHz for Quasi Peak detection at frequency below 1GHz.
- The resolution bandwidth of test receiver/spectrum analyzer is 1MHz and video bandwidth is 3MHz with Peak detection for Peak measurement at frequency above 1GHz.
The resolution bandwidth of test receiver/spectrum analyzer is 1MHz and the video bandwidth is 10Hz with Peak detection for Average Measurement as below at frequency above 1GHz.
- Steps 2 and 3 were repeated for the next frequency point, until all selected frequency points were measured.

Remark

Result Pass Fail

Test Data Yes N/A

Test Plot Yes (See below) N/A

Test Result:

Test Mode:	Transmitting Mode
-------------------	-------------------

Frequency range: 9KHz - 30MHz

Freq. (MHz)	Detection value	Factor (dB/m)	Reading (dBuV/m)	Result (dBuV/m)	Limit@3m (dBuV/m)	Margin (dB)
--	--	--	--	--	--	>20
--	--	--	--	--	--	>20

Note:

The amplitude of spurious emissions which are attenuated by more than 20dB below the permissible value has no need to be reported.

Distance extrapolation factor = $40 \log (\text{specific distance}/\text{test distance})$ (dB);

Limit line = specific limits(dBuv) + distance extrapolation factor.

Test Mode: Bluetooth Mode

30MHz -1GHz

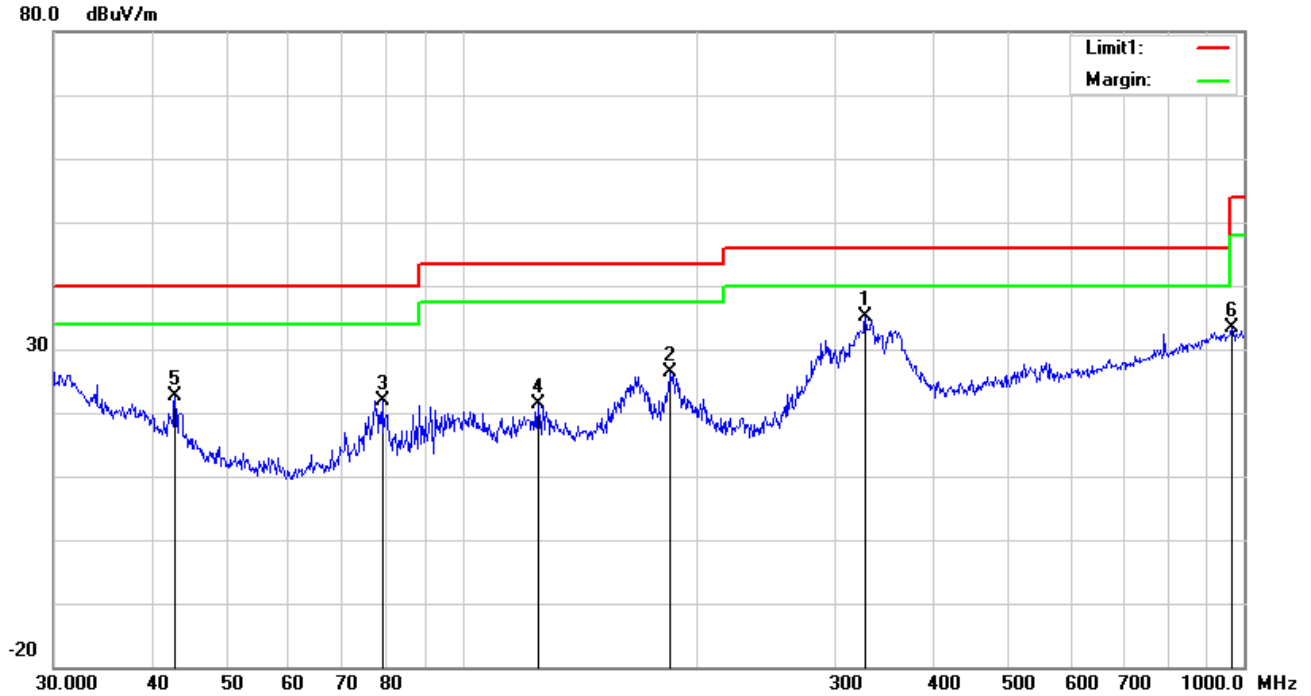

Test Data

Horizontal Polarity Plot @3m

No.	P/L	Frequency (MHz)	Reading (dBuV/m)	Detector	Ant_F (dB/m)	PA_G (dB)	Cab_L (dB)	Result (dBuV/m)	Limit (dBuV/m)	Margin (dB)	Height (cm)	Degree (°)
1	H	327.8873	41.28	peak	14.19	22.21	1.93	35.19	46.00	-10.81	100	186
2	H	184.4898	36.01	peak	11.25	22.28	1.44	26.42	43.50	-17.08	100	120
3	H	78.9652	35.62	peak	7.62	22.42	1.03	21.85	40.00	-18.15	100	222
4	H	125.0066	28.88	peak	13.57	22.37	1.18	21.26	43.50	-22.24	100	74
5	H	42.8998	32.11	peak	11.99	22.29	0.77	22.58	40.00	-17.42	100	315
6	H	965.5421	28.00	peak	22.83	20.76	3.26	33.33	54.00	-20.67	200	222

30MHz -1GHz

80.0 dBuV/m

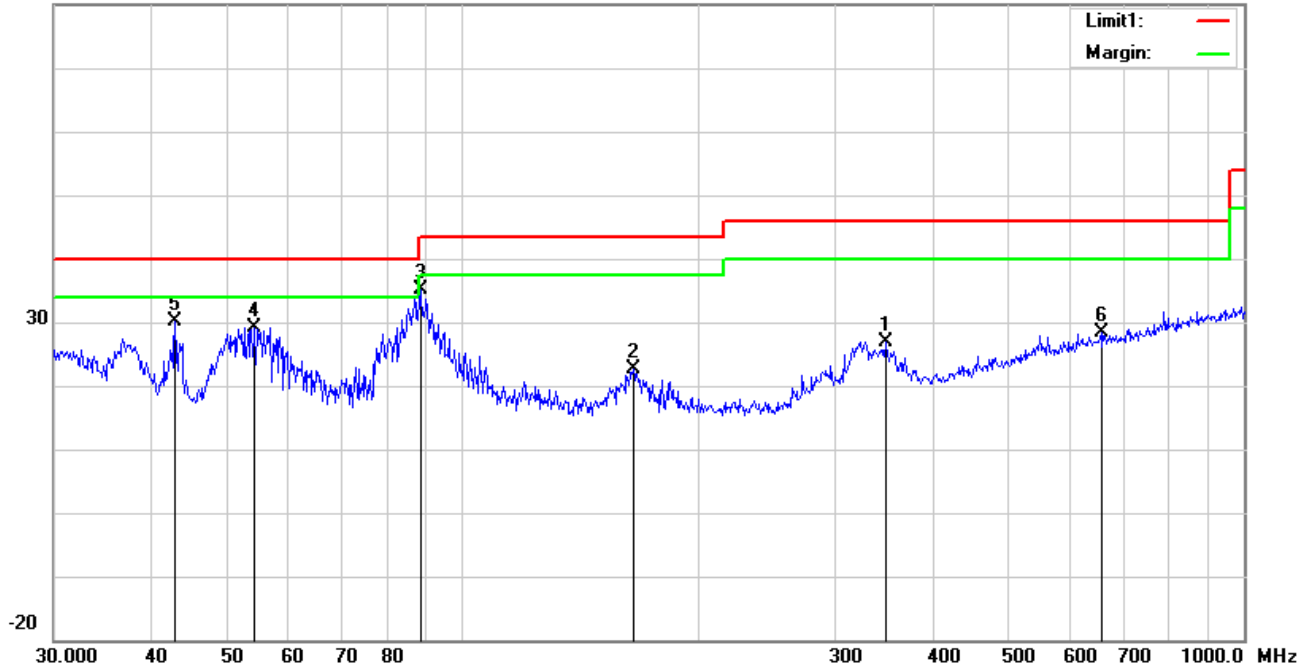

Test Data

Vertical Polarity Plot @3m

No.	P/L	Frequency (MHz)	Reading (dBuV/m)	Detector	Ant_F (dB/m)	PA_G (dB)	Cab_L (dB)	Result (dBuV/m)	Limit (dBuV/m)	Margin (dB)	Height (cm)	Degree (°)
1	V	348.0274	32.48	peak	14.61	22.16	2.03	26.96	46.00	-19.04	100	266
2	V	165.4867	31.31	peak	12.16	22.26	1.37	22.58	43.50	-20.92	100	251
3	V	88.3421	48.52	peak	7.93	22.34	0.99	35.10	43.50	-8.40	200	78
4	V	54.2610	42.81	peak	7.93	22.39	0.78	29.13	40.00	-10.87	100	78
5	V	42.8998	39.64	peak	11.99	22.29	0.77	30.11	40.00	-9.89	100	70
6	V	656.5300	27.60	peak	19.72	21.46	2.62	28.48	46.00	-17.52	100	254

Above 1GHz

Test Mode:	Transmitting Mode
-------------------	--------------------------

Frequency	Meter Reading	Antenna Factor	Cable loss	Preamp factor	Emission Level	Limits	Margin	Detector	Polarity
(MHz)	(dBμV)	(dB)	(dB)	(dB)	(dBμV/m)	(dBμV/m)	(dB)	(PK/AV)	(H/V)
Low Channel:8DPSK Mode(Worst Case)-2402MHz									
2390	36.85	28.72	3.36	26.32	42.61	74	-31.39	peak	Vertical
4804	29.14	32.94	3.98	27.49	38.57	54	-15.43	Average	Vertical
4804	37.38	32.94	3.98	27.49	46.81	74	-27.19	peak	Vertical
7203	30.25	25.28	5.51	27.94	33.10	54	-20.90	Average	Vertical
7203	39.41	25.28	5.51	27.94	42.26	74	-31.74	peak	Vertical
2390	37.98	28.72	3.36	26.32	43.74	74	-30.26	peak	Horizontal
4804	30.25	32.94	3.98	27.49	39.68	54	-14.32	Average	Horizontal
4804	40.47	32.94	3.98	27.49	49.90	74	-24.10	peak	Horizontal
7203	31.58	25.28	5.51	27.94	34.43	54	-19.57	Average	Horizontal
7203	40.35	25.28	5.51	27.94	43.20	74	-30.80	peak	Horizontal
Middle Channel:8DPSK Mode(Worst Case)-2441MHz									
4880	30.25	32.11	4.04	27.53	38.87	54	-15.13	Average	Vertical
4880	36.14	32.11	4.04	27.53	44.76	74	-29.24	peak	Vertical
7324	30.78	24.33	5.58	27.96	32.73	54	-21.27	Average	Vertical
7324	38.25	24.33	5.58	27.96	40.20	74	-33.80	peak	Vertical
4880	29.10	32.11	4.04	27.53	37.72	54	-16.28	Average	Horizontal
4880	40.14	32.11	4.04	27.53	48.76	74	-25.24	peak	Horizontal
7324	33.33	24.33	5.58	27.96	35.28	54	-18.72	Average	Horizontal
7324	39.12	24.33	5.58	27.96	41.07	74	-32.93	peak	Horizontal
High Channel:8DPSK Mode(Worst Case)-2480MHz									
2483.2	37.25	28.79	3.48	26.34	43.18	74	-30.82	peak	Vertical
4959.2	30.15	31.32	4.12	27.58	38.01	54	-15.99	Average	Vertical
4959.2	38.78	31.32	4.12	27.58	46.64	74	-27.36	peak	Vertical
74340	29.32	24.38	5.68	27.99	31.39	54	-22.61	Average	Vertical
74340	41.52	24.38	5.68	27.99	43.59	74	-30.41	peak	Vertical
2483.2	39.98	28.79	3.48	26.34	45.91	74	-28.09	peak	Horizontal
4959.2	28.36	31.32	4.12	27.58	36.22	54	-17.78	Average	Horizontal
4959.2	39.89	31.32	4.12	27.58	47.75	74	-26.25	peak	Horizontal
74340	32.55	24.38	5.68	27.99	34.62	54	-19.38	Average	Horizontal
74340	40.38	24.38	5.68	27.99	42.45	74	-31.55	peak	Horizontal

Note:

- 1, The testing has been conformed to 10*2480MHz=24,800MHz
- 2, All other emissions more than 30 dB below the limit
- 3, X-Axis, Y-Axis and Z-Axis were investigated. The results above show only the worst case.
- 4, The radiated spurious test above 18GHz is subcontracted to SIEMIC (Nanjing-China) Laboratories. and found 30dB below the limit at least.

Annex A. TEST INSTRUMENT

Instrument	Model	Serial #	Cal Date	Cal Due	In use
AC Line Conducted					
EMI test receiver	ESCS30	8471241027	09/15/2017	09/14/2018	<input checked="" type="checkbox"/>
Line Impedance	LI-125A	191106	09/23/2017	09/22/2018	<input checked="" type="checkbox"/>
Line Impedance	LI-125A	191107	09/23/2017	09/22/2018	<input checked="" type="checkbox"/>
ISN	ISN T800	34373	09/23/2017	09/22/2018	<input type="checkbox"/>
Transient Limiter	LIT-153	531118	08/30/2017	08/29/2018	<input type="checkbox"/>
RF conducted test					
Agilent ESA-E SERIES	E4407B	MY45108319	09/15/2017	09/14/2018	<input checked="" type="checkbox"/>
Power Splitter	1#	1#	08/30/2017	08/29/2018	<input checked="" type="checkbox"/>
DC Power Supply	E3640A	MY40004013	09/15/2017	09/14/2018	<input checked="" type="checkbox"/>
Radiated Emissions					
EMI test receiver	ESL6	100262	09/15/2017	09/14/2018	<input checked="" type="checkbox"/>
Positioning Controller	UC3000	MF780208282	11/17/2017	11/16/2018	<input checked="" type="checkbox"/>
OPT 010 AMPLIFIER (0.1-1300MHz)	8447E	2727A02430	08/30/2017	08/29/2018	<input checked="" type="checkbox"/>
Microwave Preamplifier (1 ~ 26.5GHz)	8449B	3008A02402	03/22/2018	03/21/2019	<input checked="" type="checkbox"/>
Horn Antenna	BBHA9170	3145226D1	09/27/2017	09/26/2018	<input checked="" type="checkbox"/>
Active Antenna (9kHz-30MHz)	AL-130	121031	10/12/2017	10/11/2018	<input checked="" type="checkbox"/>
Bilog Antenna (30MHz~6GHz)	JB6	A110712	09/19/2017	09/18/2018	<input checked="" type="checkbox"/>
Double Ridge Horn Antenna (1 ~18GHz)	AH-118	71283	09/22/2017	09/21/2018	<input checked="" type="checkbox"/>
Universal Radio Communication Tester	CMU200	121393	09/23/2017	09/22/2018	<input checked="" type="checkbox"/>

Annex B. EUT And Test Setup Photographs

Annex B.i. Photograph: EUT External Photo

Whole Package View



EUT - Front View



EUT - Rear View



EUT - Bottom View 1



EUT - Bottom View 2



EUT – Top View



EUT - Right View



Annex B.ii. Photograph: EUT Internal Photo

Mainboard - Front View

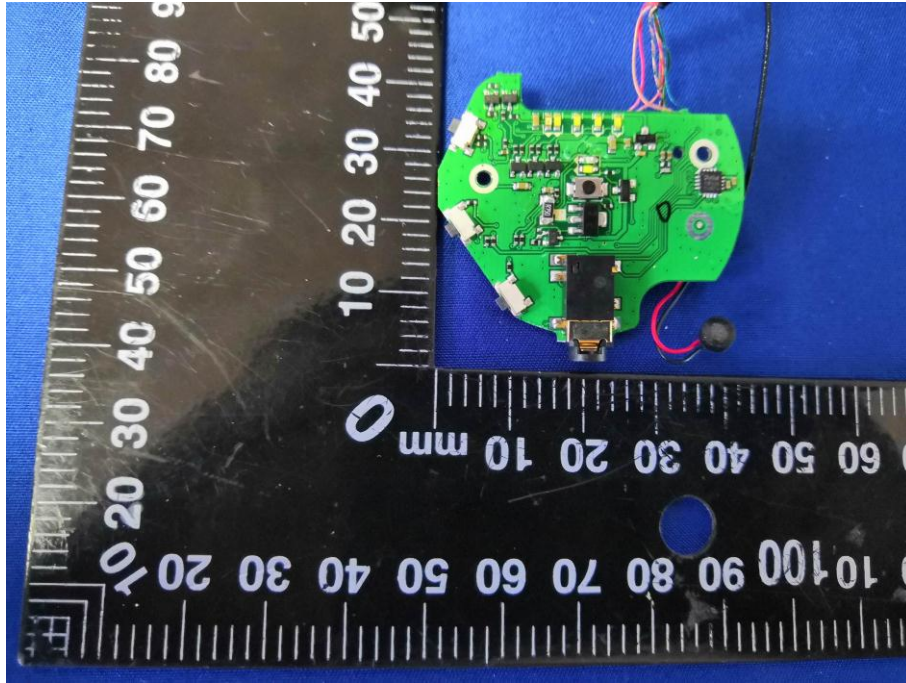

Mainboard - Rear View

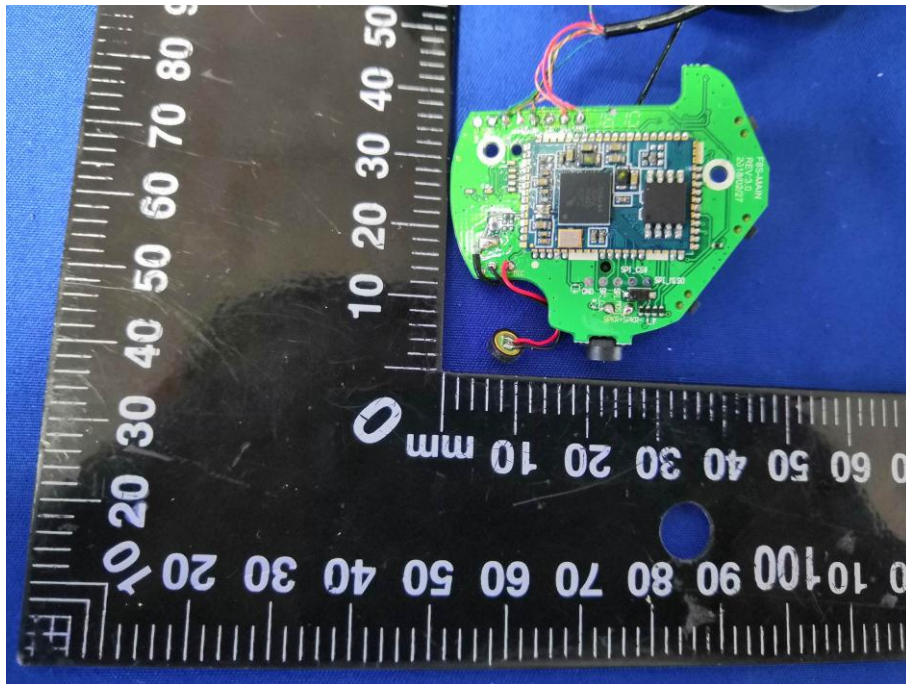

Small board - Front View

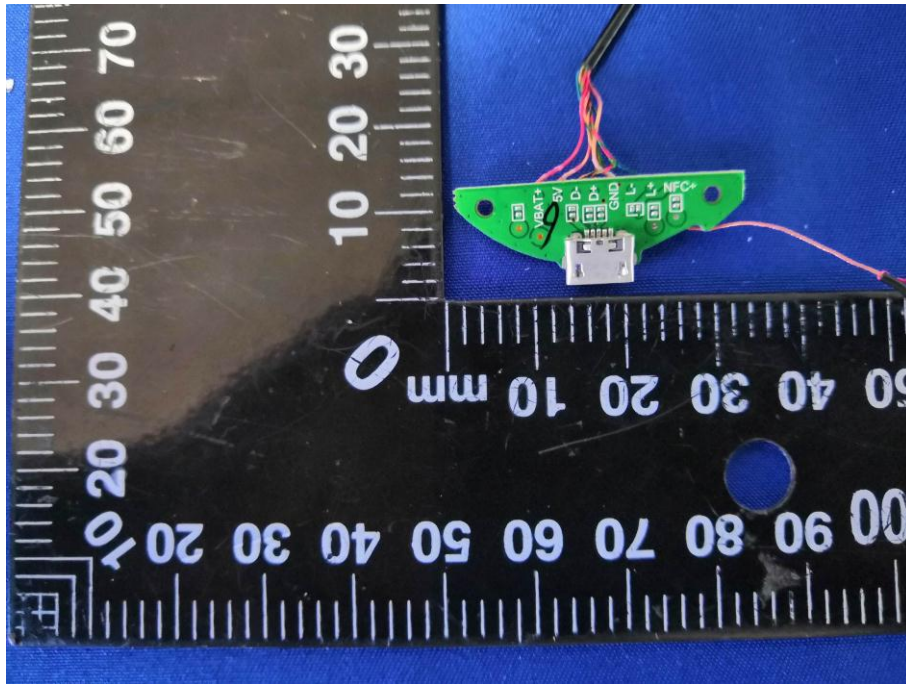

Small board - Rear View

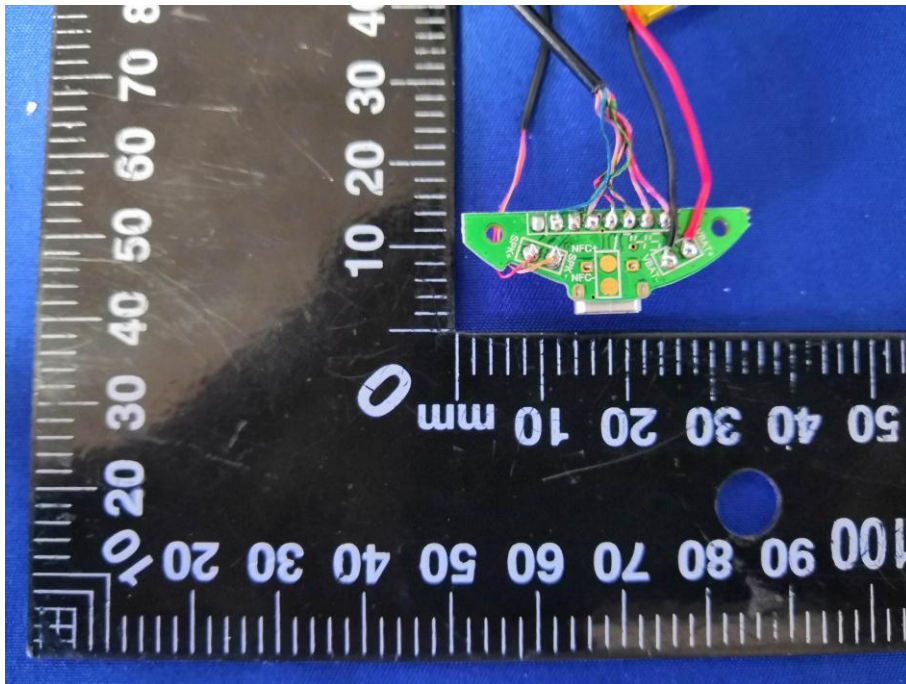

Battery - Front View

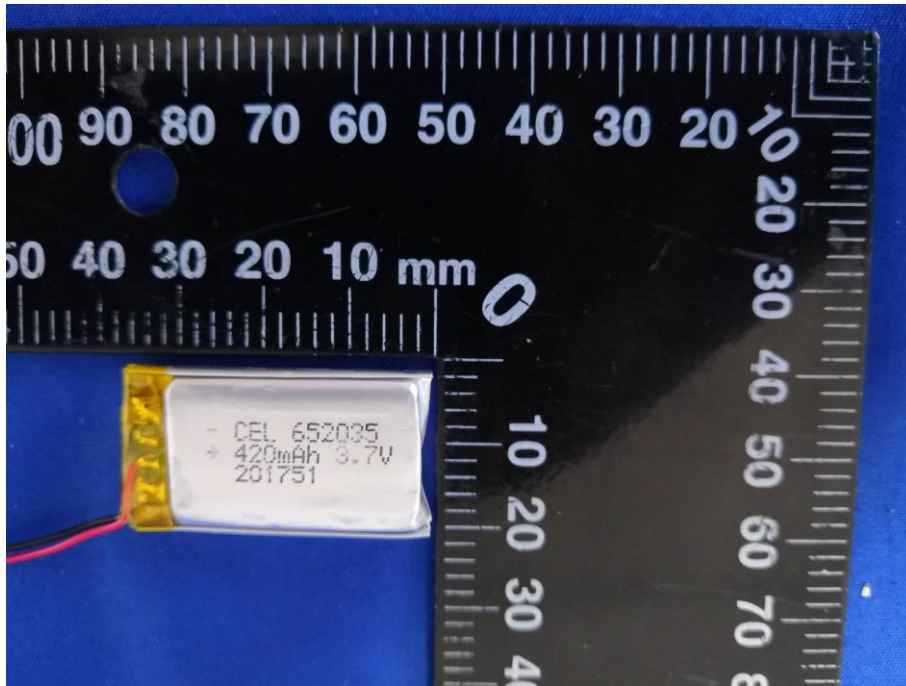

Battery - Rear View

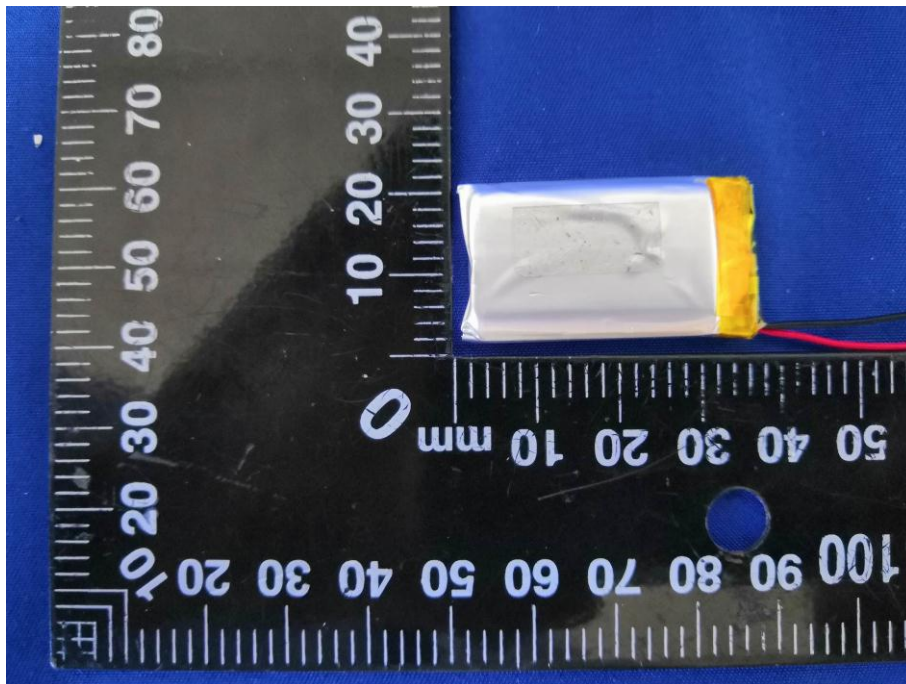

BT - Antenna View

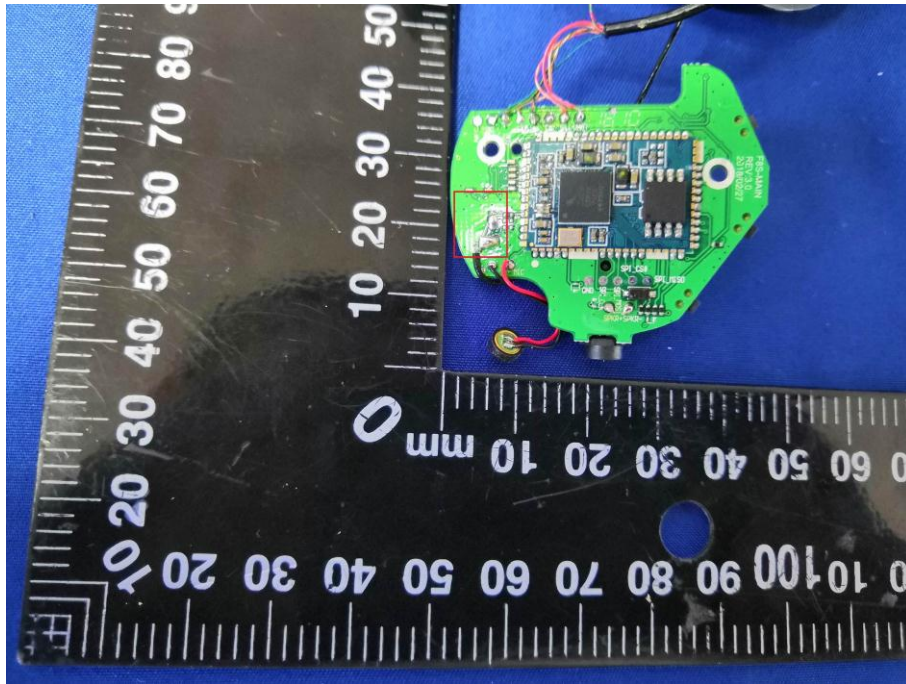

Annex B.iii. Photograph: Test Setup Photo



Conducted Emissions Test Setup Front View



Conducted Emissions Test Setup Side View



Radiated Spurious Emissions Test Setup Below 1GHz

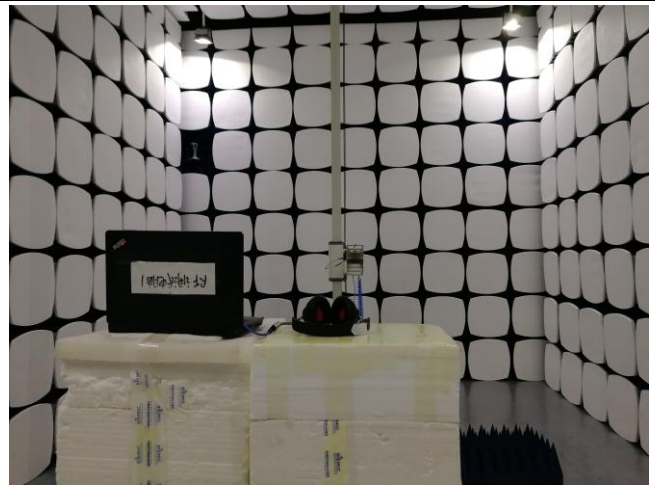

Radiated Spurious Emissions Test Setup Above 1GHz

Annex C. TEST SETUP AND SUPPORTING EQUIPMENT

Annex C.ii. TEST SET UP BLOCK

Block Configuration Diagram for AC Line Conducted Emissions

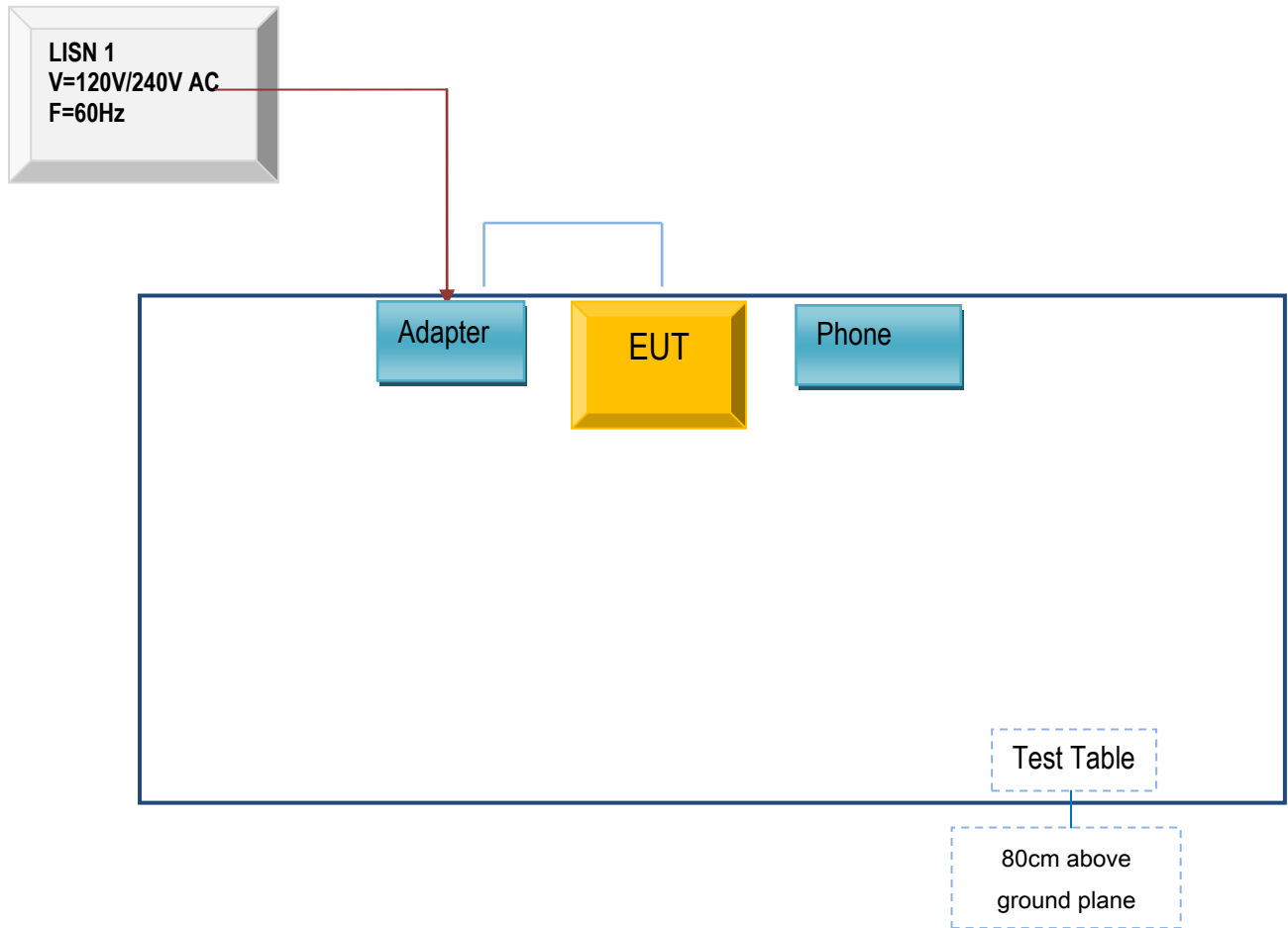

Block Configuration Diagram for Radiated Emissions (Below 1GHz) .

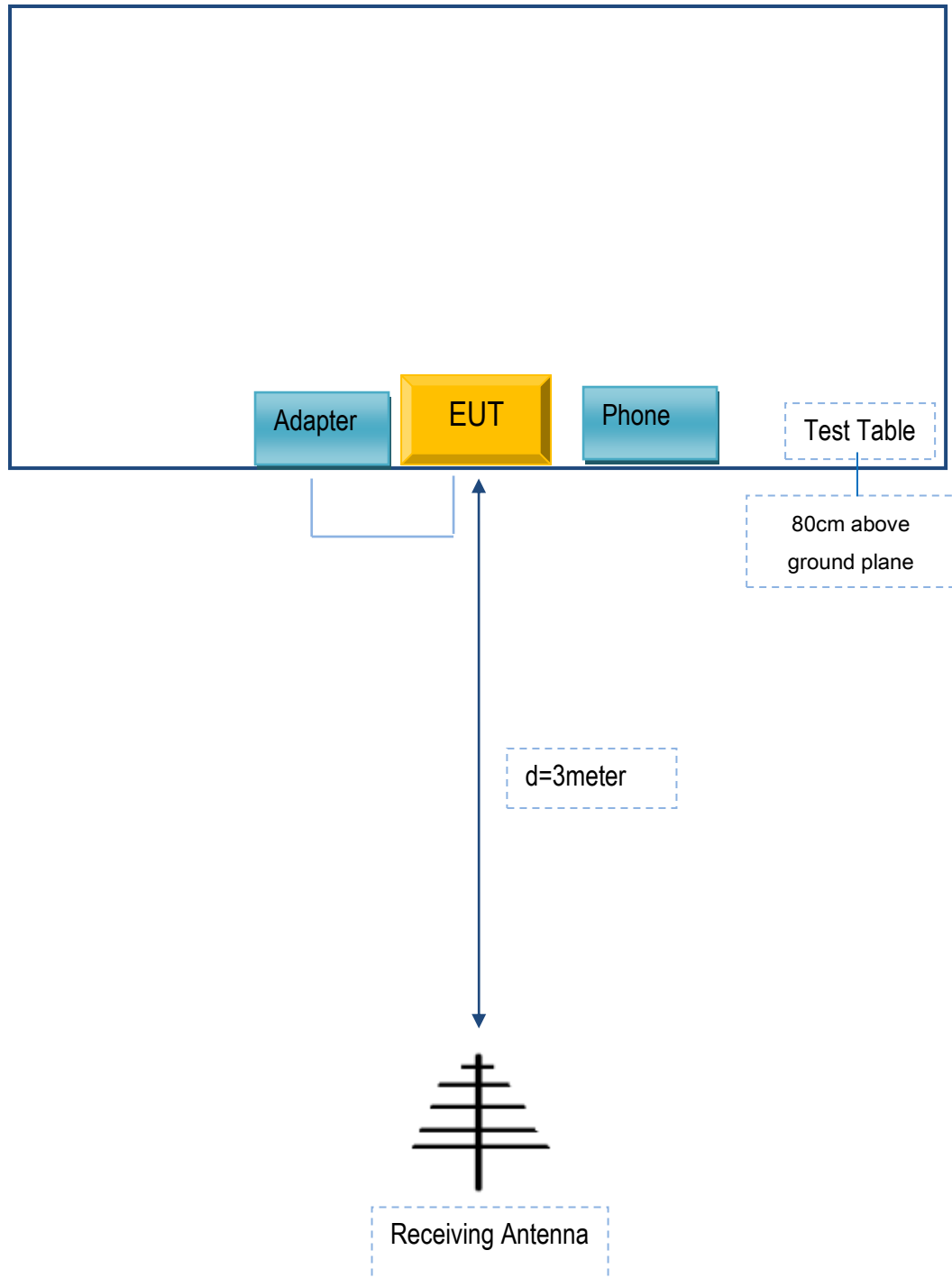

Block Configuration Diagram for Radiated Emissions (Above 1GHz) .

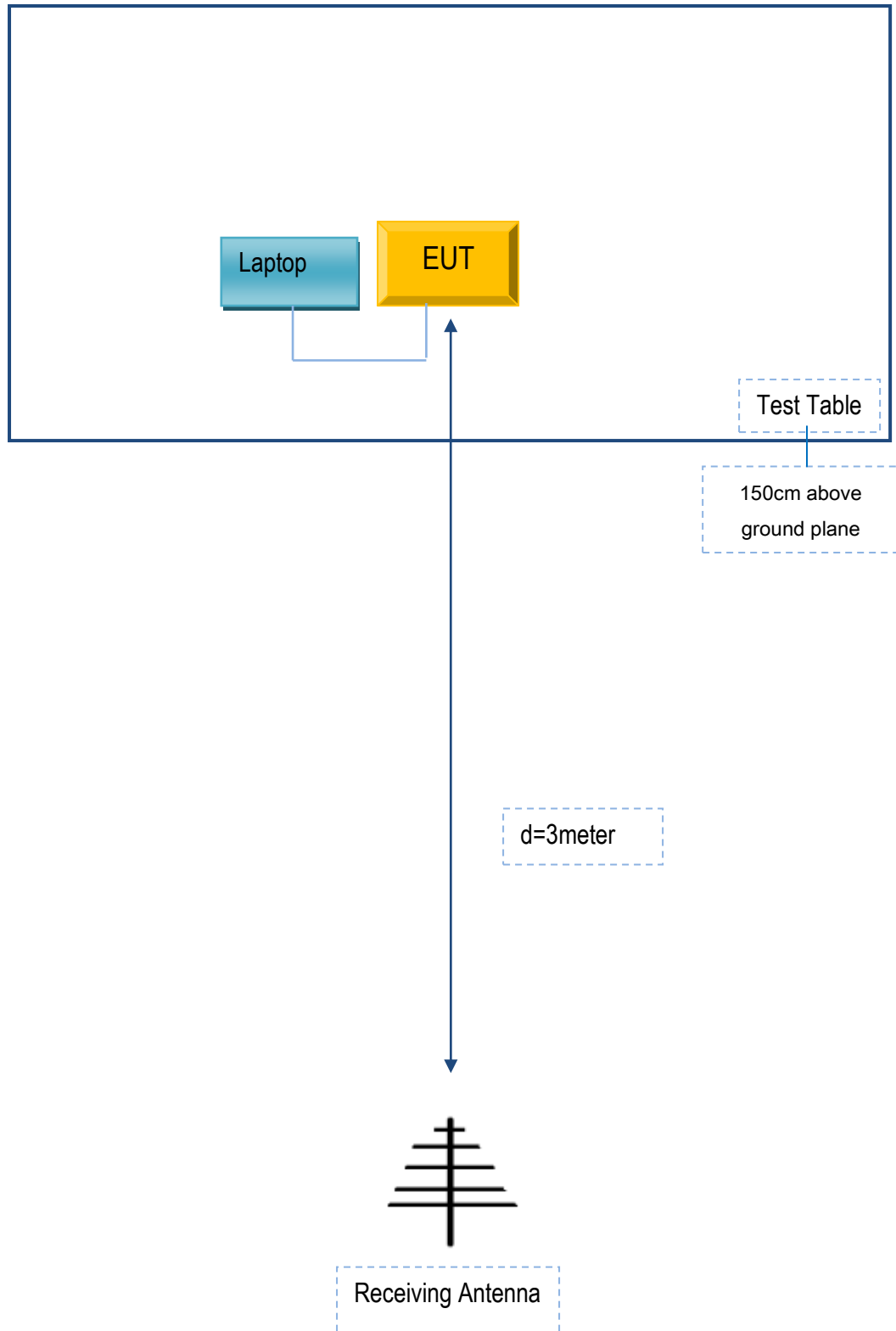

Annex C. ii. SUPPORTING EQUIPMENT DESCRIPTION

The following is a description of supporting equipment and details of cables used with the EUT.

Supporting Equipment:

Manufacturer	Equipment Description	Model	Serial No
Lenovo	Laptop	E40	LR-1EHRX
Huawei	Phone	Honor 9	N/A

Supporting Cable:

Cable type	Shield Type	Ferrite Core	Length	Serial No
Power Line	Un-shielding	No	0.8m	N/A

Test Report	18070475-FCC-R1
Page	58 of 59

Annex D. User Manual / Block Diagram / Schematics / Partlist

Please see the attachment

Test Report	18070475-FCC-R1
Page	59 of 59

Annex E. DECLARATION OF SIMILARITY

N/A