

**ELECTROMAGNETIC EMISSIONS COMPLIANCE REPORT  
INTENTIONAL RADIATOR CERTIFICATION TO  
FCC PART 15 SUBPART C  
REQUIREMENT T**

*OF*

Speaker Box

MODEL No.: M4000

Trademark: N/A

FCC ID: 2AEOS-M4000

REPORT NO: ES150324247E

ISSUE DATE: June 10, 2015

*Prepared for*

BRITELITE ENTERPRISES.

11901 SANTA MONICA BLVD 3413, LOS ANGELES ,CA 90025

*Prepared by*

SHENZHEN EMTEK CO., LTD

Bldg 69, Majialong Industry Zone, Nanshan District,  
Shenzhen, Guangdong, China

TEL:0086-755-26954280

FAX: 0086-755-26954282

## VERIFICATION OF COMPLIANCE

Applicant	:	BRITELITE ENTERPRISES. 11901 SANTA MONICA BLVD 3413,LOS ANGELES ,CA 90025
Manufacturer	:	BRITELITE ENTERPRISES. 11901 SANTA MONICA BLVD 3413,LOS ANGELES ,CA 90025
Product Description	:	Speaker Box
Brand Name	:	N/A
Model Number	:	M4000
File Number	:	ES150324247E
Date of Test:	:	March 25, 2015 to May 07, 2015

**We hereby certify that:**

The above equipment was tested by SHENZHEN EMTEK CO., LTD. The test data, data evaluation, test procedures, and equipment configurations shown in this report were made in accordance with the procedures given in ANSI C63.10-2013 and the energy emitted by the sample EUT tested as described in this report is in compliance with conducted and radiated emission limits of FCC Rules Part 15.247.

The test results of this report relate only to the tested sample identified in this report.

Date of Test : March 25, 2015 to May 07, 2015

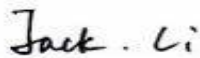
Prepared by :   
Jack Li/Editor

Reviewer :   
Joe Xia/Supervisor

Approve & Authorized Signer :   
Lisa Wang/Manager

## TABLE OF CONTENTS

<b>1. GENERAL INFORMATION .....</b>	<b>5</b>
1.1 Product Description .....	5
1.2 Related Submittal(s) / Grant (s).....	5
1.3 Test Methodology .....	5
1.4 Special Accessories .....	5
1.5 Equipment Modifications .....	5
1.6 Test Facility.....	6
<b>2. SYSTEM TEST CONFIGURATION.....</b>	<b>7</b>
2.1 EUT Configuration .....	7
2.2 EUT Exercise.....	7
2.3 Test Procedure .....	7
2.4 Limitation .....	8
2.5 Configuration of Tested System .....	10
2.6 Equipment Used in Tested System .....	11
2.7 Description of Test Modes.....	11
<b>3. SUMMARY OF TEST RESULTS .....</b>	<b>12</b>
<b>4. CONDUCTED EMISSIONS TEST .....</b>	<b>13</b>
4.1 Measurement Procedure .....	13
4.2 Test SET-UP (Block Diagram of Configuration).....	13
4.3 Measurement Equipment Used .....	13
4.4 Measurement Equipment Used.....	13
<b>5. RADIATED EMISSION TEST .....</b>	<b>20</b>
5.1 Measurement Procedure .....	20
5.2 Test SET-UP (Block Diagram of Configuration).....	20
5.3 Measurement Equipment Used .....	21
5.4 Measurement Result .....	21
<b>6. CHANNEL SEPARATION TEST.....</b>	<b>36</b>
6.1 Measurement Procedure .....	36
6.2 Test SET-UP (Block Diagram of Configuration).....	36
6.3 Measurement Equipment Used .....	36
6.4 Measurement Results.....	36
<b>7. BANDWIDTH TEST .....</b>	<b>42</b>
7.1 Measurement Procedure .....	42
7.2 Test SET-UP (Block Diagram of Configuration).....	42
7.3 Measurement Equipment Used .....	42
7.4 Measurement Results.....	42

<b>8. QUANTITY OF HOPPING CHANNEL TEST .....</b>	<b>49</b>
8.1 Measurement Procedure .....	49
8.2 Test SET-UP (Block Diagram of Configuration) .....	49
8.3 Measurement Equipment Used .....	49
8.4 Measurement Results .....	49
<b>9. TIME OF OCCUPANCY (DWELL TIME) TEST .....</b>	<b>52</b>
9.1 Measurement Procedure .....	52
9.2 Test SET-UP (Block Diagram of Configuration) .....	52
9.3 Measurement Equipment Used .....	52
9.4 Measurement Results .....	52
<b>10. MAXIMUM PEAK OUTPUT POWER TEST .....</b>	<b>68</b>
10.1 Measurement Procedure .....	68
10.2 Test SET-UP (Block Diagram of Configuration) .....	68
10.3 Measurement Equipment Used .....	68
10.4 Measurement Results .....	68
<b>11. BAND EDGE TEST .....</b>	<b>74</b>
11.1 Applicable Standard .....	74
11.2 Measurement Procedure .....	74
11.3 Measurement Equipment Used .....	74
11.4 Measurement Results .....	74
<b>12. ANTENNA PORT EMISSION .....</b>	<b>90</b>
12.1 Test Equipment .....	90
12.2 Measuring Instruments and setting .....	90
12.3 Test Procedures .....	90
12.4 Block Diagram of Test setup .....	90
12.5 Test Result .....	90
<b>13. ANTENNA APPLICATION .....</b>	<b>94</b>
13.1 Antenna requirement .....	94
13.2 Result .....	94

## 1. General Information

### 1.1 Product Description

BRITELITE ENTERPRISES

Model:M4000 (referred to as the EUT in this report) The EUT (Speaker Box) is an short range, lower power Device. It is designed by way of utilizing the GFSK,  $\pi/4$ -DQPSK and 8DPSK modulation achieves the system operating.

A major technical descriptions of EUT is described as following:

- A). Operation Frequency: 2402-2480MHz
- B). Modulation: GFSK,  $\pi/4$ -DQPSK, 8DPSK
- C). Number of Channel: 79
- D). Channel Space: 1MHz
- E). BIT Rate of Transmission: 1Mbps, 2Mbps, 3Mbps
- F). Antenna Type: PCB antenna
- G). Antenna Gain: 0dBi
- H). Power Supply: AC 120V, 50/60Hz

### 1.2 Related Submittal(s) / Grant (s)

This submittal(s) (test report) is intended for 2AEOS-M4000 filing to comply with Section 15.247 of the FCC Part 15 Subpart C Rules.

### 1.3 Test Methodology

Both conducted and radiated testing were performed according to the procedures in ANSI C63.10 -2013. Radiated testing was performed at an antenna to EUT distance 3 meters.

### 1.4 Special Accessories

Not available for this EUT intended for grant.

### 1.5 Equipment Modifications

Not available for this EUT intended for grant.

## 1.6 Test Facility

Site Description  
EMC Lab.

: Accredited by CNAS, 2013.10.29  
The certificate is valid until 2016.10.28  
The Laboratory has been assessed and proved to be in compliance with  
CNAS/CL01:2006(identical to ISO/IEC17025: 2005)  
The Certificate Registration Number is L2291

Accredited by TUV Rheinland Shenzhen 2010.5.25  
The Laboratory has been assessed according to the requirements ISO/IEC  
17025

Accredited by FCC, April 17, 2014  
The Certificate Registration Number is 406365.

Accredited by Industry Canada, March 5, 2010  
The Certificate Registration Number is 4480A-2.

Name of Firm : SHENZHEN EMTEK CO., LTD  
Site Location : Bldg 69, Majialong Industry Zone, Nanshan District, Shenzhen,  
Guangdong, China

## **2. System Test Configuration**

### **2.1 EUT Configuration**

The EUT configuration for testing is installed on RF field strength measurement to meet the Commissions requirement and operating in a manner which intends to maximize its emission characteristics in a continuous normal application.

### **2.2 EUT Exercise**

The Transmitter was operated in the normal operating mode. The Tx frequency was fixed which was for the purpose of the measurements.

### **2.3 Test Procedure**

#### **2.3.1 Conducted Emissions**

The EUT is placed on a turn table which is 0.8 m above ground plane. According to the requirements in Section 6.2 of ANSI C63.10-2013, conducted emissions from the EUT are measured in the frequency range between 0.15 MHz and 30 MHz using CISPR Quasi-Peak and average detector mode.

#### **2.3.2 Radiated Emissions**

The turn table shall rotate 360 degrees to determine the position of maximum emission level. EUT is set 3m away from the receiving antenna which varied from 1m to 4m to find out the highest emission. And also, each emission was to be maximized by changing the polarization of receiving antenna both horizontal and vertical. In order to find out the max. emission, the relative positions of this Speaker Box (EUT) were rotated through three orthogonal axes according to the requirements in section 6.4, section 6.5 and section 6.6 of ANSI C63.10-2013.

## 2.4 Limitation

### (1) Channel Separation Test

FCC Part 15, Subpart C Section 15.247(a)(1) Frequency hopping systems shall have hopping channel carrier frequencies separated by a minimum of 25kHz or the 20dB Bandwidth of the hopping channel, whichever is greater.

Frequency Range (MHz)	Limit(kHz)
902-928	>25kHz
2400-2483.5	>25kHz
5725-5850	>25kHz

### (2) 20dB Bandwidth

Frequency Range(MHz)	Quantity of Hopping Channel	Limit(kHz)			
		50	25	15	75
902-928		<250	>250	NA	NA
2400-2483.5		NA	NA	>1000	<1000

### (3) Quantity of Hopping Channel

FCC Part 15, Subpart C Section 15.247

Frequency Range (MHz)	20dB bandwidth <250kHz	Limit(Quantity of Hopping Channel)		
		20dB bandwidth >250k Hz	20dB bandwidth <1MHz	20dB bandwidth >1MHz
902-928	50	25	NA	NA
2400-2483.5	NA	NA	75	15
5725-5850	NA	NA	75	NA

### (4) Time of Occupancy(Dwell Time)

FCC Part 15, Subpart C Section 15.247

Frequency Range (MHz)	20dB bandwidth <250kHz(50Channel)	LIMIT(rms)	
		20dB bandwidth >250kHz(25 Channel)	20dB bandwidth <1MHz(75Channel)
902-928	400(20S)	400(10S)	NA
2400-2483.5	NA	NA	400(30S)
5725-5850	NA	NA	400(30S)

**Note:** The “( )” is all channel’s average time of occupancy.



**(5) Maximum Peak Output Power**

FCC Part 15, Subpart C Section 15.247

Frequency Range (MHz)	Quantity of Hopping Channel	LIMIT(W)			
		50	25	15	75
902-928		1(30dBm)	0.125(21dBm)	NA	NA
2400-2483.5		NA	NA	0.125(21dBm)	1(30dBm)
5725-5850		NA	NA	NA	1(30dBm)

**(6) Band edge**

FCC Part15, Subpart C Section 15.247, In any 100kHz bandwidth outside the frequency band in with the spread spectrum intentional radiator is operating, the radio frequency power that is produced by the intentional radiator shall be at least 20dB below that in the 100kHz bandwidth within the band that contains the highest level of the desired power, based on either an RF conducted or a radiated measurement, attenuation below the general limits specified in section 15.209(a) is not required. In addition, radiated emissions which fall in the restricted bands, as defined in section 15.205(a), must also comply with the radiated emission limits specified in section 15.209(a).

Operating Frequency Range(MHz)	Spurious emission frequency	Limit Peak power ration to emission(dBc)	Emission level(dBuV/m)
	>928	>20	NA
	960-1240	NA	54
2400-2483.5	<2400	>20	NA
	>2483.5-2500	NA	54
5725-5850	<5350-5460	NA	54
	<5725	>20	NA
	>5850	>20	NA

**(7) Conducted Emission**

Frequency(MHz)	Quasi-peak	Average
0.15-0.5	66-56	56-46
0.5-5.0	56	46
5.0-30.0	60	50

**Note:**

1. The lower limit shall apply at the transition frequencies
2. The limit decreases in line with the logarithm of the frequency in the range of 0.15 to 0.50MHz.

**(8) Radiated Emission**

FCC Part 15, Subpart C Section 15.209 limit of radiated emission for frequency below 1000GHz. The emissions from an intentional radiator shall not exceed the field strength level specified in the following table:

Frequency (MHz)	Field strength $\mu\text{V/m}$	Distance(m)	Field strength at 3m $\text{dB}\mu\text{V/m}$
0.009~0.490	2400/F(KHz)	300	/
0.490~1.705	2400/F(KHz)	30	/
1.705~30.0	30	30	/
30-88	100	3	40
88-216	150	3	43.5
216-960	200	3	46
Above 960	500	3	54

- Remark:
1. Emission level in  $\text{dB}\mu\text{V/m} = 20 \log(\mu\text{V/m})$
  2. Measurement was performed at an antenna to the closed point of EUT distance of meters.
  3. Distance extrapolation factor  $= 40 \log(\text{Specific distance} / \text{test distance})$  (dB);  
Limit line = Specific limits (dB $\mu\text{V}$ ) + distance extrapolation factor.

**2.5 Configuration of Tested System**



## 2.6 Equipment Used in Tested System

Item	Equipment	Mfr/Brand	Model/Type No.	FCC ID	Series No.	Note
1.	Speaker Box	N/A	M4000	2AEOS-M4000	N/A	EUT
\		\	\	\	\	\

**Note:**

- (1) Unless otherwise denoted as EUT in 『Remark』 column, device(s) used in tested system is a support equipment.

## 2.7 Description of Test Modes

The EUT (Speaker Box) has been tested under normal operating condition. This EUT is a FHSS system. Pre-scanned tests, were conducted to determine the final configuration from all possible combinations. We use software control the EUT, Let EUT hopping on and transmit with highest power, all the modes have been tested. 79 Channels are provided by EUT. The 3 channels of lower, medium and higher were chosen for test

Channel	Frequency(MHz)
Low channel	2402
Middle channel	2441
High channel	2480

### 3. Summary of Test Results

<b>FCC Rules</b>	<b>Description Of Test</b>	<b>Result</b>
FCC Part 15.247(a)(1)	Channel Separation Test	Compliant
FCC Part 15.247(a)(1)	20dB Bandwidth	Compliant
FCC Part 15.247(a)(1)	Quantity of Hopping Channel	Compliant
FCC Part 15.247(a)(1)	Time of Occupancy (Dwell Time)	Compliant
FCC Part 15.247(b)	Max Peak Output Power Test	Compliant
FCC Part 15.247(d)	Band Edge Test	Compliant
FCC Part 15.207	Conducted Emission	Compliant
FCC Part 15.247(d)&15.209	Radiated Emission	Compliant
FCC Part 15.247(d)	Antenna Port Emission	Compliant
FCC Part 15.203&15.247(b)	Antenna Requirement	Compliant

## 4. Conducted Emissions Test

### 4.1 Measurement Procedure

1. The EUT was placed on a table which is 0.1m above ground plane.
2. Maximum procedure was performed on the three highest emissions to ensure EUT compliance.
3. Repeat above procedures until all frequency measured were complete.

### 4.2 Test SET-UP (Block Diagram of Configuration)

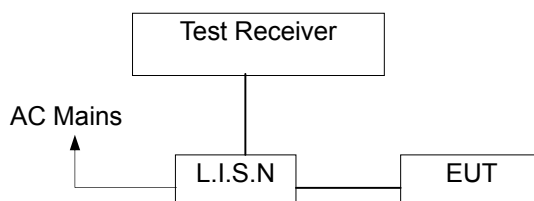

### 4.3 Measurement Equipment Used

Conducted Emission Test Site					
EQUIPMENT TYPE	MFR	MODEL NUMBER	SERIAL NUMBER	LAST CAL.	CAL DUE.
Test Receiver	Rohde & Schwarz	ESCS30	828985/018	05/17/2014	05/16/2015
L.I.S.N.	Rohde & Schwarz	ENV216	101161	05/17/2014	05/16/2015
L.I.S.N.	Schwarzbeck	NNLK8129	8129203	05/17/2014	05/17/2015
50Ω Coaxial Switch	Anritsu	MP59B	M20531	N/A	N/A
Pulse Limiter	Rohde & Schwarz	ESH3-Z2	100006	05/17/2014	05/17/2015

### 4.4 Measurement Equipment Used

Pass.  
Please refer to the following data.

USB Mode:

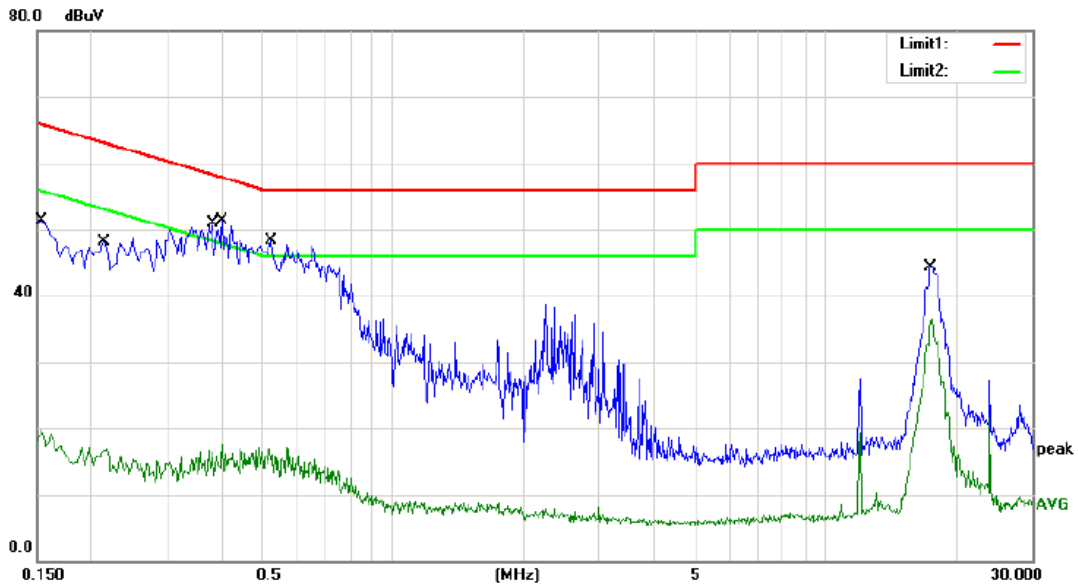

Site site #1 Phase: **L1** Temperature: 20  
 Limit: (CE)FCC PART 15 class B\_QP Power: AC 120V/60Hz Humidity: 51 %  
 Mode: USB Mode  
 Note:

No. Mk.	Freq. MHz	Reading Level dBuV	Correct Factor dB	Measure- ment dBuV	Limit dBuV	Over dB	Detector	Comment
1	0.1540	40.30	11.00	51.30	65.78	-14.48	QP	
2	0.1540	8.70	11.00	19.70	55.78	-36.08	AVG	
3	0.2140	37.10	11.00	48.10	63.05	-14.95	QP	
4	0.2140	5.70	11.00	16.70	53.05	-36.35	AVG	
5	0.3820	39.90	11.00	50.90	58.24	-7.34	QP	
6	0.3820	4.40	11.00	15.40	48.24	-32.84	AVG	
7 *	0.4020	40.20	11.00	51.20	57.81	-6.61	QP	
8	0.4020	6.40	11.00	17.40	47.81	-30.41	AVG	
9	0.5220	37.20	11.00	48.20	56.00	-7.80	QP	
10	0.5220	4.20	11.00	15.20	46.00	-30.80	AVG	
11	17.4920	33.40	11.00	44.40	60.00	-15.60	QP	
12	17.4920	25.10	11.00	36.10	50.00	-13.90	AVG	

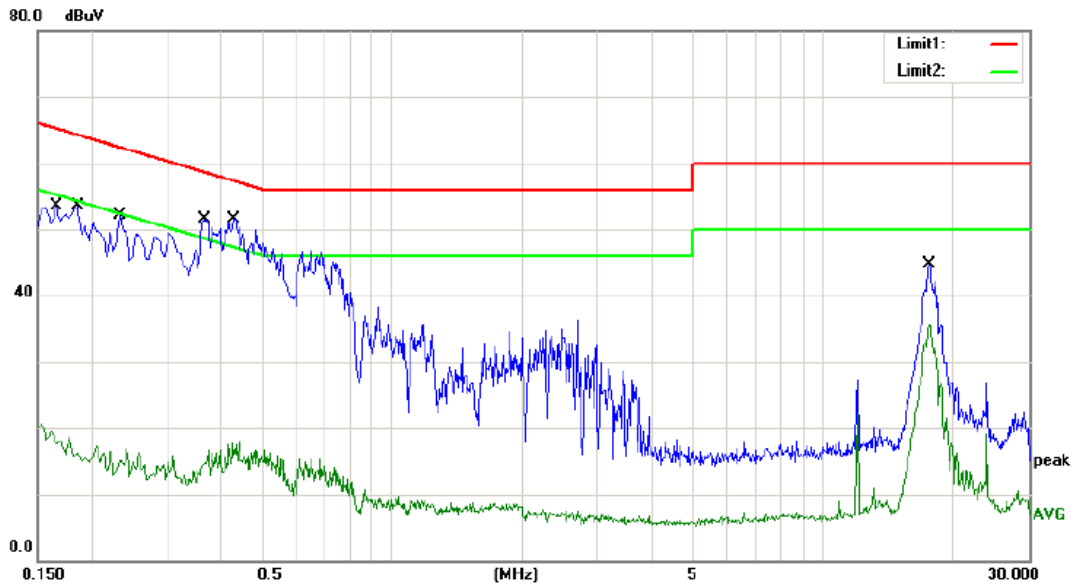

Site site #1 Phase: **N** Temperature: 20  
 Limit: (CE)FCC PART 15 class B\_QP Power: AC 120V/60Hz Humidity: 51 %  
 Mode: USB Mode  
 Note:

No.	Mk.	Freq.	Reading Level	Correct Factor	Measurement	Limit	Over	Detector	Comment
		MHz	dBuV	dB	dBuV	dBuV	dB		
1		0.1660	42.50	11.00	53.50	65.16	-11.66	QP	
2		0.1660	6.70	11.00	17.70	55.16	-37.46	AVG	
3		0.1860	42.50	11.00	53.50	64.21	-10.71	QP	
4		0.1860	5.10	11.00	16.10	54.21	-38.11	AVG	
5		0.2340	41.00	11.00	52.00	62.31	-10.31	QP	
6		0.2340	4.20	11.00	15.20	52.31	-37.11	AVG	
7		0.3660	40.40	11.00	51.40	58.59	-7.19	QP	
8		0.3660	3.60	11.00	14.60	48.59	-33.99	AVG	
9	*	0.4300	40.50	11.00	51.50	57.25	-5.75	QP	
10		0.4300	5.00	11.00	16.00	47.25	-31.25	AVG	
11		17.6560	33.60	11.00	44.60	60.00	-15.40	QP	
12		17.6560	24.70	11.00	35.70	50.00	-14.30	AVG	

BT mode

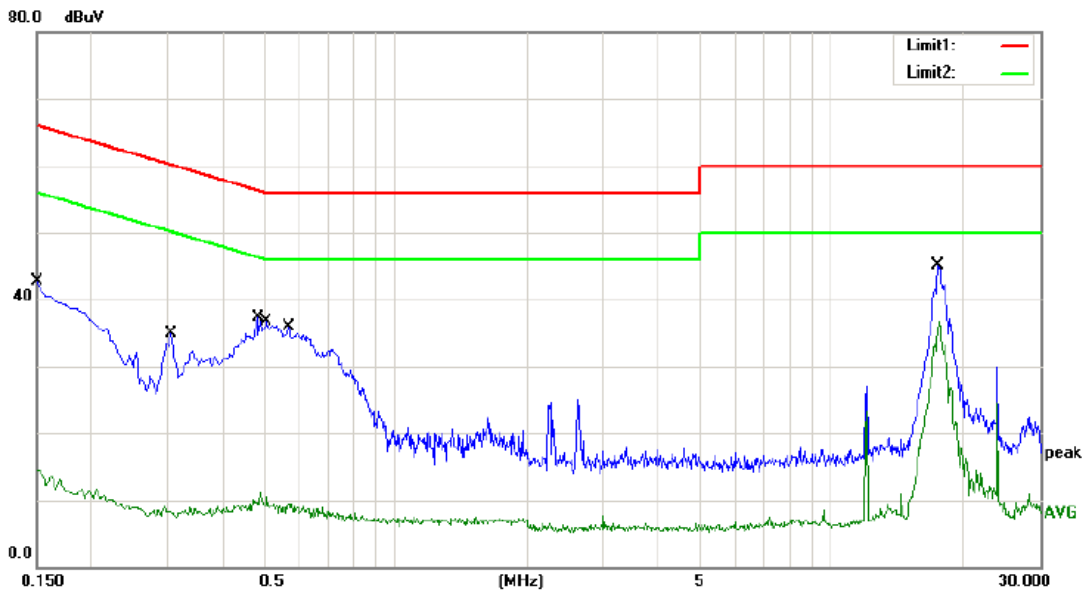

Site site #1 Phase: **L1** Temperature: 20  
 Limit: (CE)FCC PART 15 class B\_QP Power: AC 120V/60Hz Humidity: 51 %  
 Mode: BT Mode  
 Note:

No.	Mk.	Freq. MHz	Reading Level dBuV	Correct Factor dB	Measure- ment dBuV	Limit dBuV	Over dB	Detector	Comment
1		0.1500	31.70	11.00	42.70	66.00	-23.30	QP	
2		0.1500	3.50	11.00	14.50	56.00	-41.50	AVG	
3		0.3060	23.90	11.00	34.90	60.08	-25.18	QP	
4		0.3060	-2.70	11.00	8.30	50.08	-41.78	AVG	
5		0.4820	26.40	11.00	37.40	56.30	-18.90	QP	
6		0.4860	-1.60	11.00	9.40	46.24	-36.84	AVG	
7		0.5060	25.70	11.00	36.70	56.00	-19.30	QP	
8		0.5060	-0.50	11.00	10.50	46.00	-35.50	AVG	
9		0.5700	24.90	11.00	35.90	56.00	-20.10	QP	
10		0.5700	-1.50	11.00	9.50	46.00	-36.50	AVG	
11	*	17.5600	34.10	11.00	45.10	60.00	-14.90	QP	
12		17.5600	24.10	11.00	35.10	50.00	-14.90	AVG	



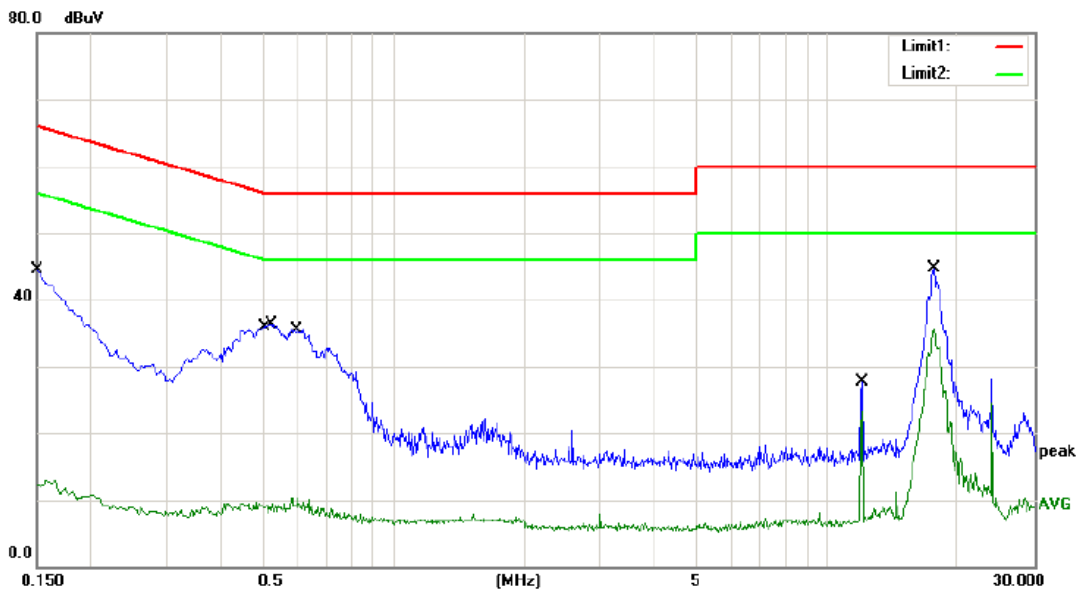

Site site #1 Phase: **N** Temperature: 20  
 Limit: (CE)FCC PART 15 class B\_QP Power: AC 120V/60Hz Humidity: 51 %  
 Mode: BT Mode  
 Note:

No. Mk.	Freq. MHz	Reading Level dBuV	Correct Factor dB	Measure- ment dBuV	Limit dBuV	Over dB	Detector	Comment
1	0.1500	33.50	11.00	44.50	66.00	-21.50	QP	
2	0.1500	1.30	11.00	12.30	56.00	-43.70	AVG	
3	0.4980	24.70	11.00	35.70	56.03	-20.33	QP	
4	0.4980	-1.80	11.00	9.20	46.03	-36.83	AVG	
5	0.5220	25.30	11.00	36.30	56.00	-19.70	QP	
6	0.5220	-2.40	11.00	8.60	46.00	-37.40	AVG	
7	0.5980	24.40	11.00	35.40	56.00	-20.60	QP	
8	0.5980	-0.70	11.00	10.30	46.00	-35.70	AVG	
9	12.0000	16.60	11.00	27.60	60.00	-32.40	QP	
10	12.0000	12.30	11.00	23.30	50.00	-26.70	AVG	
11	17.5920	33.70	11.00	44.70	60.00	-15.30	QP	
12 *	17.5920	24.70	11.00	35.70	50.00	-14.30	AVG	

AUX IN mode

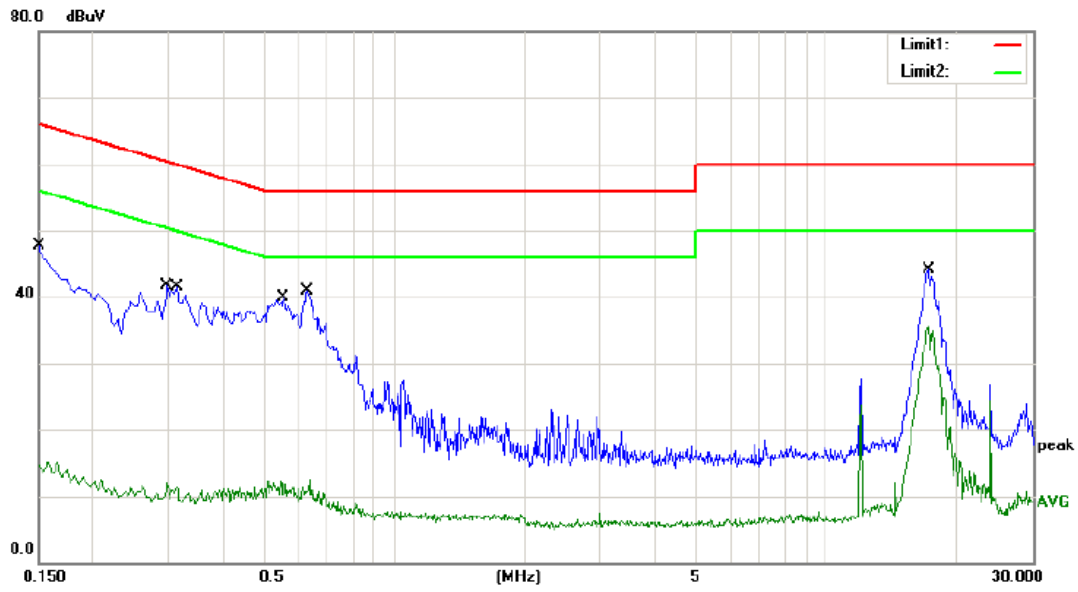

Site site #1 Phase: **N** Temperature: 20  
 Limit: (CE)FCC PART 15 class B\_QP Power: AC 120V/60Hz Humidity: 51 %  
 Mode: AUX IN  
 Note:

No. Mk.	Freq. MHz	Reading Level dBuV	Correct Factor dB	Measure- ment dBuV	Limit dBuV	Over dB	Detector	Comment
1	0.1500	36.60	11.00	47.60	66.00	-18.40	QP	
2	0.1500	3.60	11.00	14.60	56.00	-41.40	AVG	
3	0.2980	30.70	11.00	41.70	60.30	-18.60	QP	
4	0.2980	1.10	11.00	12.10	50.30	-38.20	AVG	
5	0.3140	30.50	11.00	41.50	59.86	-18.36	QP	
6	0.3140	0.50	11.00	11.50	49.86	-38.36	AVG	
7	0.5540	28.90	11.00	39.90	56.00	-16.10	QP	
8	0.5540	0.80	11.00	11.80	46.00	-34.20	AVG	
9	0.6300	29.90	11.00	40.90	56.00	-15.10	QP	
10	0.6300	-0.30	11.00	10.70	46.00	-35.30	AVG	
11	17.2080	33.00	11.00	44.00	60.00	-16.00	QP	
12 *	17.2080	24.40	11.00	35.40	50.00	-14.60	AVG	

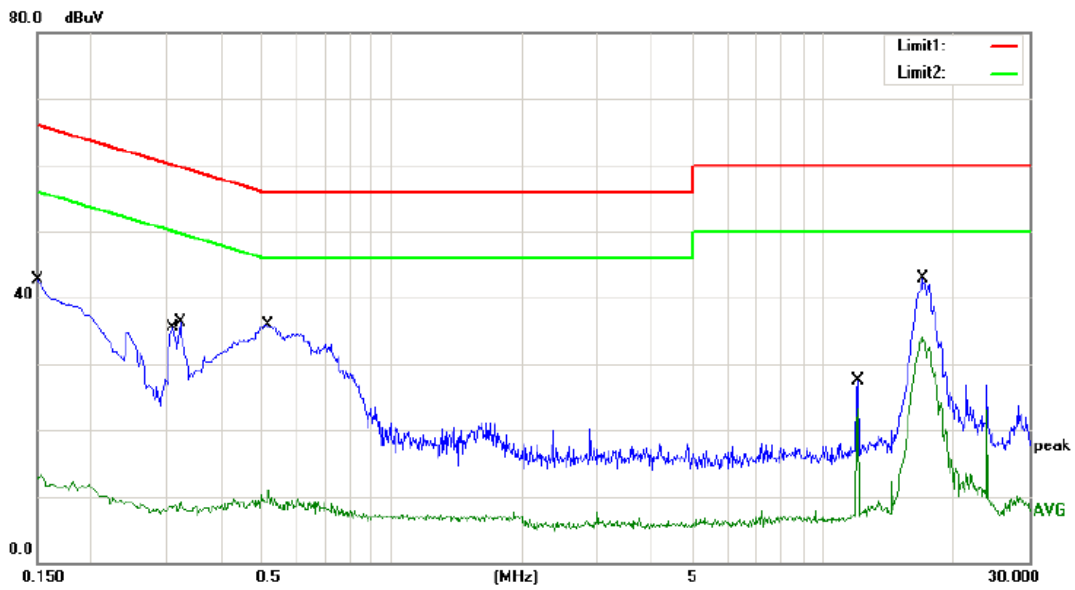

Site site #1 Phase: **L1** Temperature: 20  
 Limit: (CE)FCC PART 15 class B\_QP Power: AC 120V/60Hz Humidity: 51 %  
 Mode: AUX IN  
 Note:

No. Mk.	Freq. MHz	Reading Level dBuV	Correct Factor dB	Measure- ment dBuV	Limit dBuV	Over dB	Detector	Comment
1	0.1500	31.70	11.00	42.70	66.00	-23.30	QP	
2	0.1500	1.70	11.00	12.70	56.00	-43.30	AVG	
3	0.3100	24.50	11.00	35.50	59.97	-24.47	QP	
4	0.3100	-2.60	11.00	8.40	49.97	-41.57	AVG	
5	0.3220	25.30	11.00	36.30	59.66	-23.36	QP	
6	0.3220	-2.10	11.00	8.90	49.66	-40.76	AVG	
7	0.5180	24.90	11.00	35.90	56.00	-20.10	QP	
8	0.5180	-0.10	11.00	10.90	46.00	-35.10	AVG	
9	12.0000	16.40	11.00	27.40	60.00	-32.60	QP	
10	12.0000	12.20	11.00	23.20	50.00	-26.80	AVG	
11	17.0640	31.80	11.00	42.80	60.00	-17.20	QP	
12 *	17.0640	23.10	11.00	34.10	50.00	-15.90	AVG	

## 5. Radiated Emission Test

### 5.1 Measurement Procedure

1. The EUT was placed on a turntable which is 0.1m above ground plane.
2. Maximum procedure was performed on the six highest emissions to ensure EUT compliance.
3. And also, each emission was to be maximized by changing the polarization of receiving antenna both horizontal and vertical.
4. Repeat above procedures until all frequency measured was complete.

The frequency range from 30MHz to 1000MHz was pre-scanned with a peak detector (RBW=100kHz, VBW=300kHz) and all final readings of measurement from Test Receiver are Quasi-Peak values(Quasi Peak detector used with a bandwidth of 120 kHz).

The frequency range above 1GHz the measuring instrument use RBW=1 MHz and VBW=3 MHz with Peak Detector for Peak Values, and use RBW=1 MHz and VBW=10 Hz with Peak Detector for Average Values.

### 5.2 Test SET-UP (Block Diagram of Configuration)

(A) Radiated Emission Test Set-Up, Frequency below 30MHz

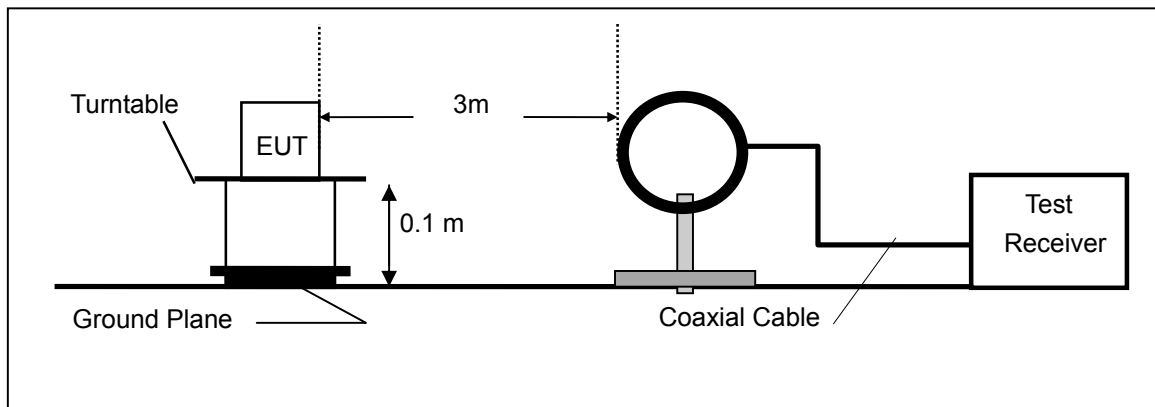

(B) Radiated Emission Test Set-Up, Frequency below 1000MHz

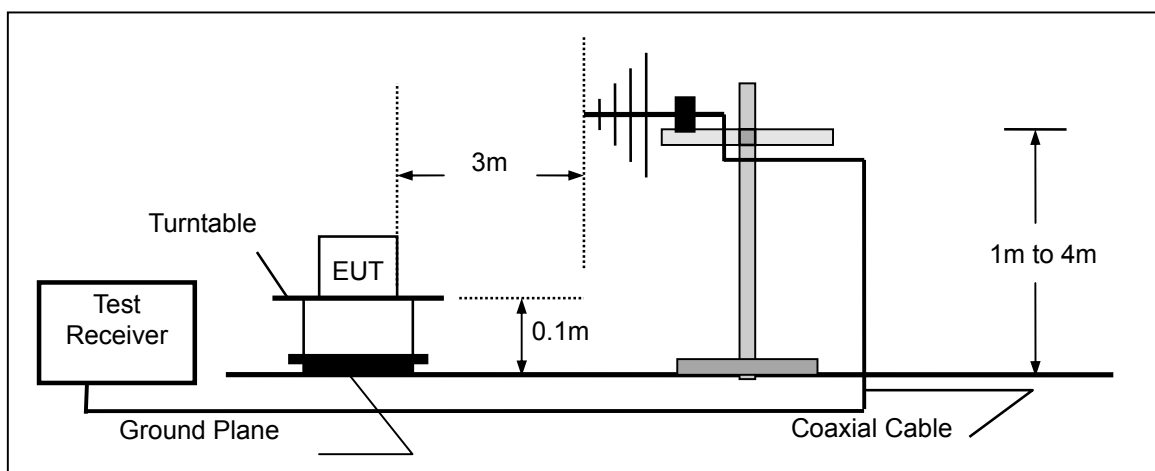

(C) Radiated Emission Test Set-Up, Frequency above 1000MHz

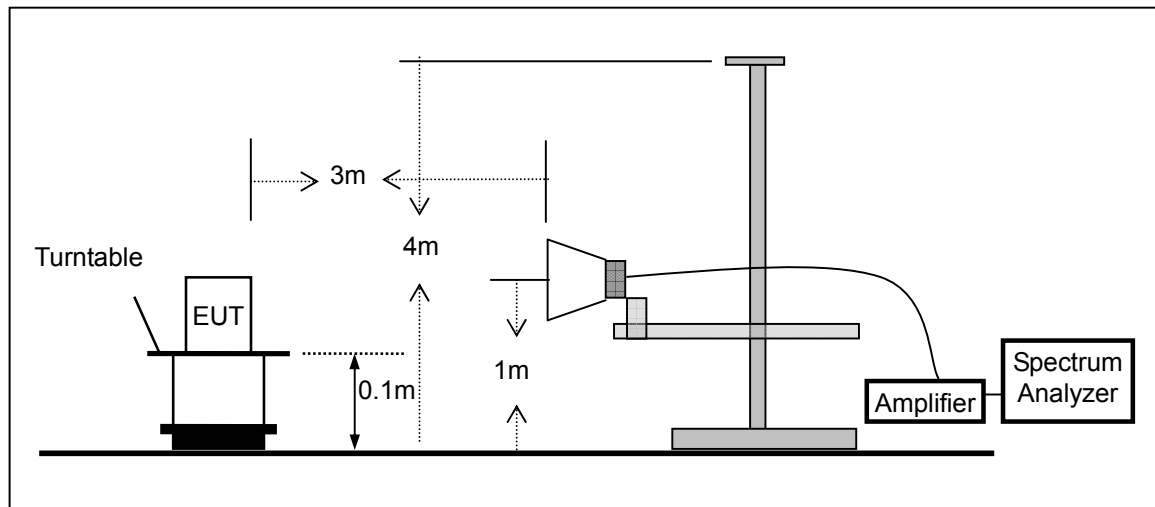

**5.3 Measurement Equipment Used**

Item	Equipment	Manufacturer	Model No.	Serial No.	Last Cal.	Cal. Interval
1.	EMI Test Receiver	Rohde & Schwarz	ESU	1302.6005.26	05/17/2014	1 Year
2.	Pre-Amplifier	HP	8447D	2944A07999	05/17/2014	1 Year
3.	Pre-Amplifier	A.H.	PAM-0126	1415261	05/17/2014	1 Year
4.	Bilog Antenna	Schwarzbeck	VULB9163	142	05/17/2014	1 Year
5.	Loop Antenna	Schwarzbeck	FMZB 1519	1519-012	05/17/2014	1 Year
6.	Horn Antenna	Schwarzbeck	BBHA 9170	BBHA9170399	05/17/2014	1 Year
7.	Horn Antenna	Schwarzbeck	BBHA 9120	D143	05/17/2014	1 Year
8.	Cable	Schwarzbeck	AK9513	ACRX1	05/17/2014	1 Year
9.	Cable	Rosenberger	N/A	FP2RX2	05/17/2014	1 Year
10.	Cable	Schwarzbeck	AK9513	CRPX1	05/17/2014	1 Year
11.	Cable	Schwarzbeck	AK9513	CRRX2	05/17/2014	1 Year

**5.4 Measurement Result**

(For range 9KHz~30MHz, The measured value is really too low to be recorded.)

**Below 1000MHz (30M-1GHz)**

**BT mode:**

(Bluetooth (GFSK, pi/4-DQPSK, 8DPSK) mode have been tested, and the worst result was report as below.)

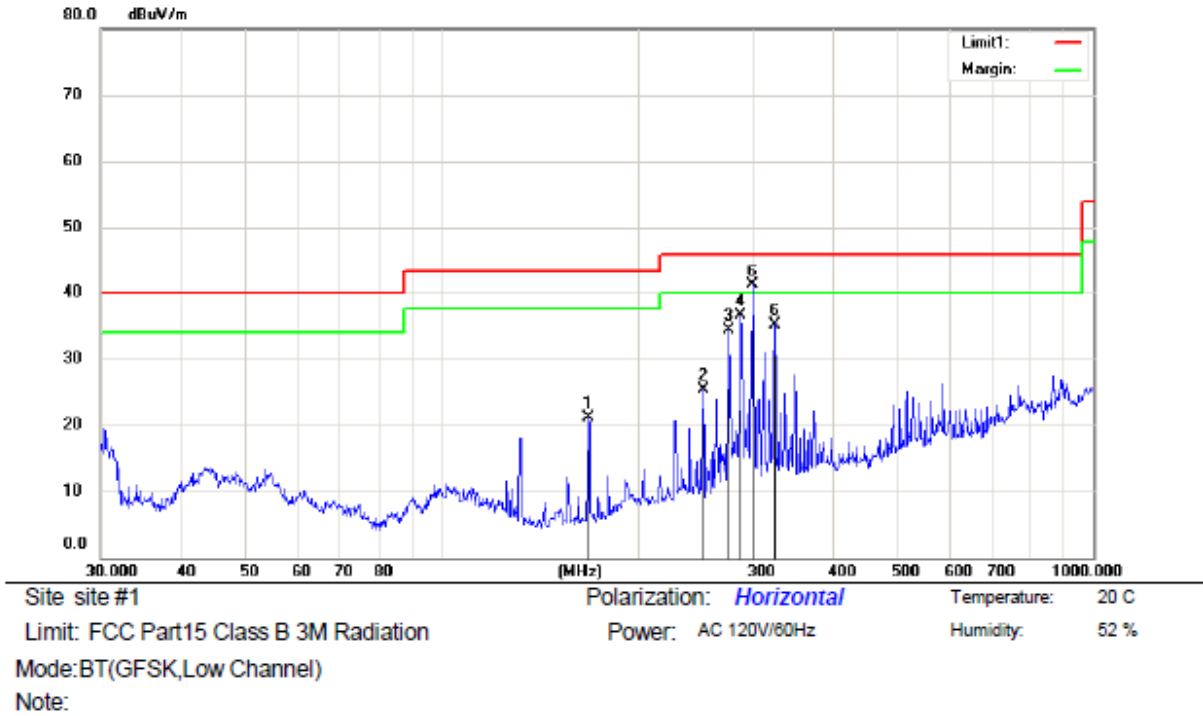

No.	Mk.	Freq.	Reading Level	Correct Factor	Measurement	Limit	Over	Antenna Height	Table Degree	
		MHz	dBuV	dB	dBuV/m	dBuV/m	dB	cm	degree	Comment
1		167.8243	46.47	-25.37	21.10	43.50	-22.40			QP
2		252.0627	46.86	-21.46	25.40	46.00	-20.60			QP
3		276.1235	53.65	-19.35	34.30	46.00	-11.70			QP
4		287.9904	55.81	-19.31	36.50	46.00	-9.50			QP
5	*	300.3672	60.15	-18.95	41.20	46.00	-4.80			QP
6		324.4561	53.27	-18.07	35.20	46.00	-10.80			QP

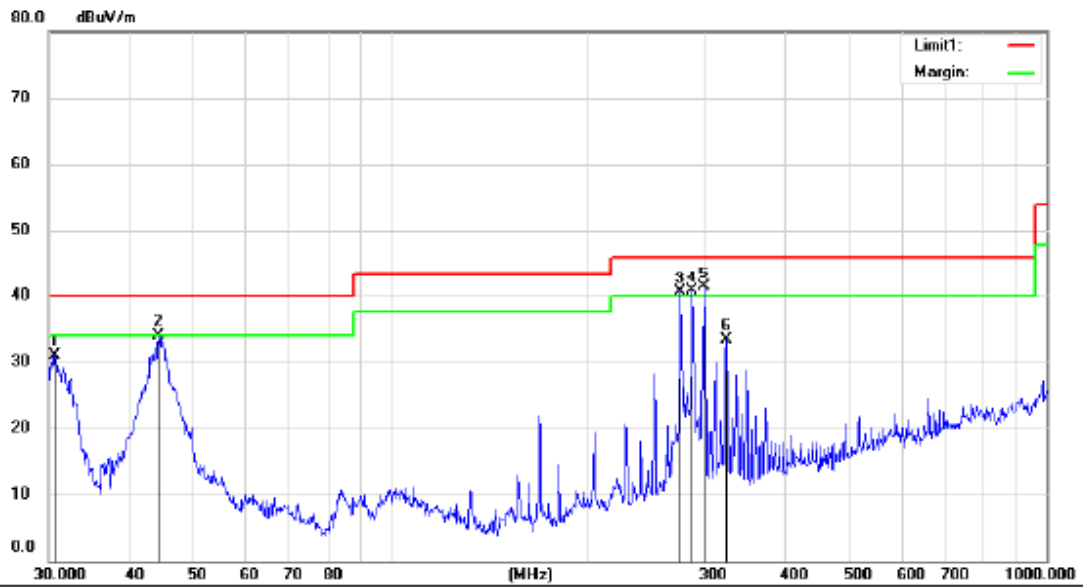

Site site #1  
 Limit: FCC Part15 Class B 3M Radiation  
 Mode:BT(GFSK,Low Channel)  
 Note:

Polarization: *Vertical*  
 Power: AC 120V/60Hz  
 Temperature: 20 C  
 Humidity: 52 %

No.	Mk.	Freq.	Reading Level	Correct Factor	Measurement	Limit	Over	Antenna Height	Table Degree
		MHz	dBuV	dB	dBuV/m	dBuV/m	dB	cm	degree
1		30.6380	55.02	-24.02	31.00	40.00	-9.00		
2		44.1202	53.90	-20.00	33.90	40.00	-6.10		
3	!	276.1235	59.95	-19.35	40.60	46.00	-5.40		
4	!	287.9904	60.01	-19.31	40.70	46.00	-5.30		
5	*	300.3672	60.25	-18.95	41.30	46.00	-4.70		
6		324.4561	51.37	-18.07	33.30	46.00	-12.70		

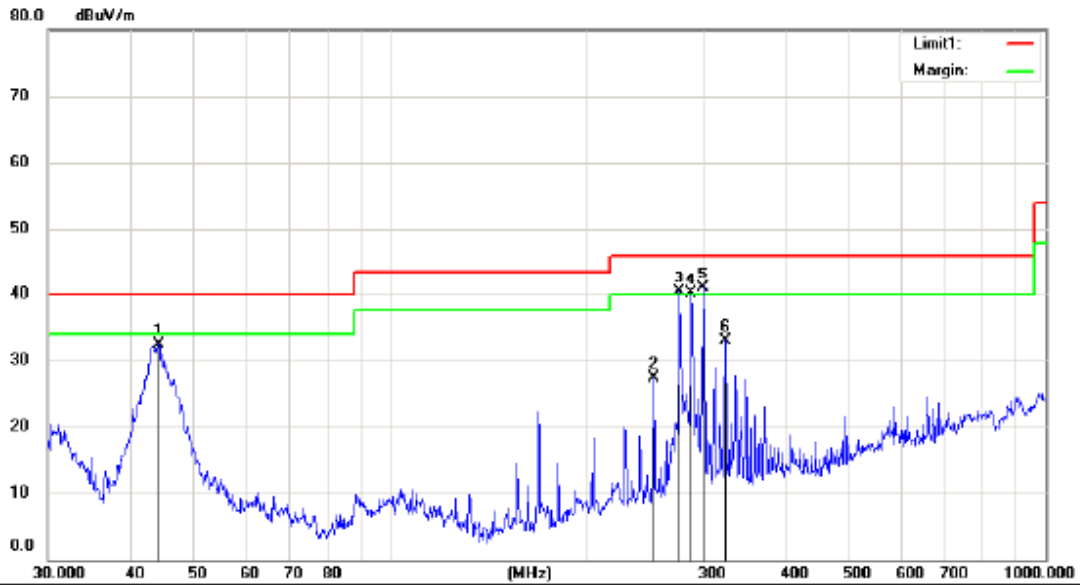

Site: site #1      Polarization: *Vertical*      Temperature: 20 C  
 Limit: FCC Part15 Class B 3M Radiation      Power: AC 120V/60Hz      Humidity: 52 %  
 Mode:BT(GFSK,Middle Channel)  
 Note:

No.	Mk.	Freq.	Reading Level	Correct Factor	Measurement	Limit	Over	Antenna Height	Table Degree
		MHz	dBuV	dB	dBuV/m	dBuV/m	dB	cm	degree
1		44.2752	52.35	-19.95	32.40	40.00	-7.60		
2		252.0627	48.76	-21.46	27.30	46.00	-18.70		
3	!	276.1235	59.75	-19.35	40.40	46.00	-5.60		
4	!	287.9904	59.41	-19.31	40.10	46.00	-5.90		
5	*	300.3672	59.95	-18.95	41.00	46.00	-5.00		
6		324.4561	51.07	-18.07	33.00	46.00	-13.00		



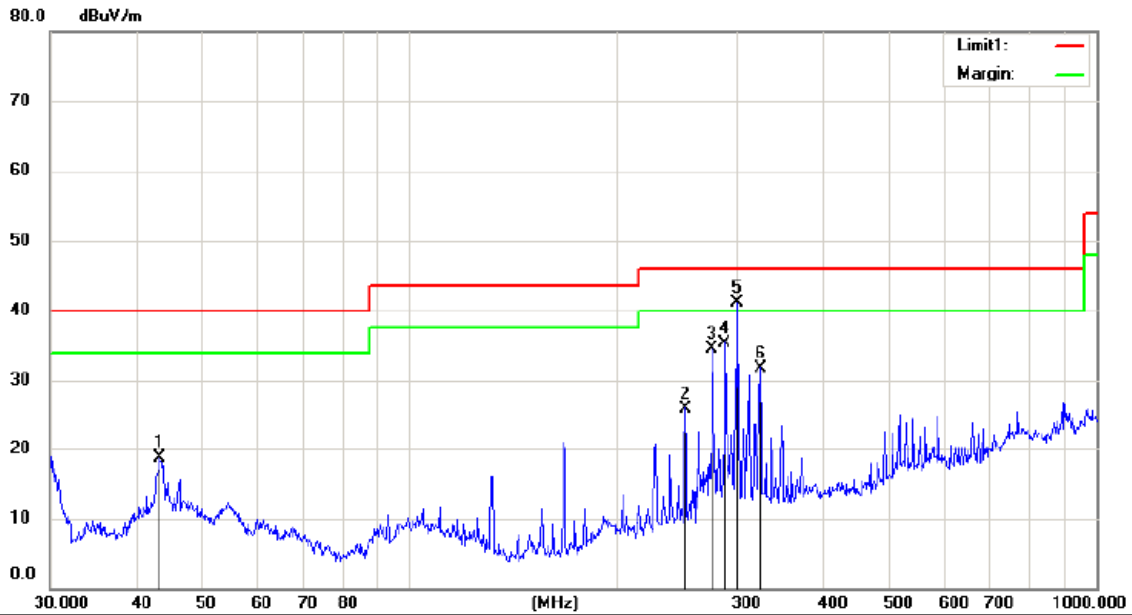

Site site #1 Polarization: **Horizontal** Temperature: 20 C  
 Limit: FCC Part15 Class B 3M Radiation Power: AC 120V/60Hz Humidity: 52 %  
 Mode:BT(GFSK,Middle Channel)  
 Note:

No.	Mk.	Freq.	Reading Level	Correct Factor	Measurement	Limit	Over	Antenna Height	Table Degree	
		MHz	dBuV	dB	dBuV/m	dBuV/m	dB	cm	degree	Comment
1		43.3534	38.80	-20.10	18.70	40.00	-21.30			QP
2		252.0627	47.46	-21.46	26.00	46.00	-20.00			QP
3		276.1235	53.85	-19.35	34.50	46.00	-11.50			QP
4		287.9904	54.71	-19.31	35.40	46.00	-10.60			QP
5	*	300.3672	60.05	-18.95	41.10	46.00	-4.90			QP
6		324.4560	49.87	-18.07	31.80	46.00	-14.20			QP

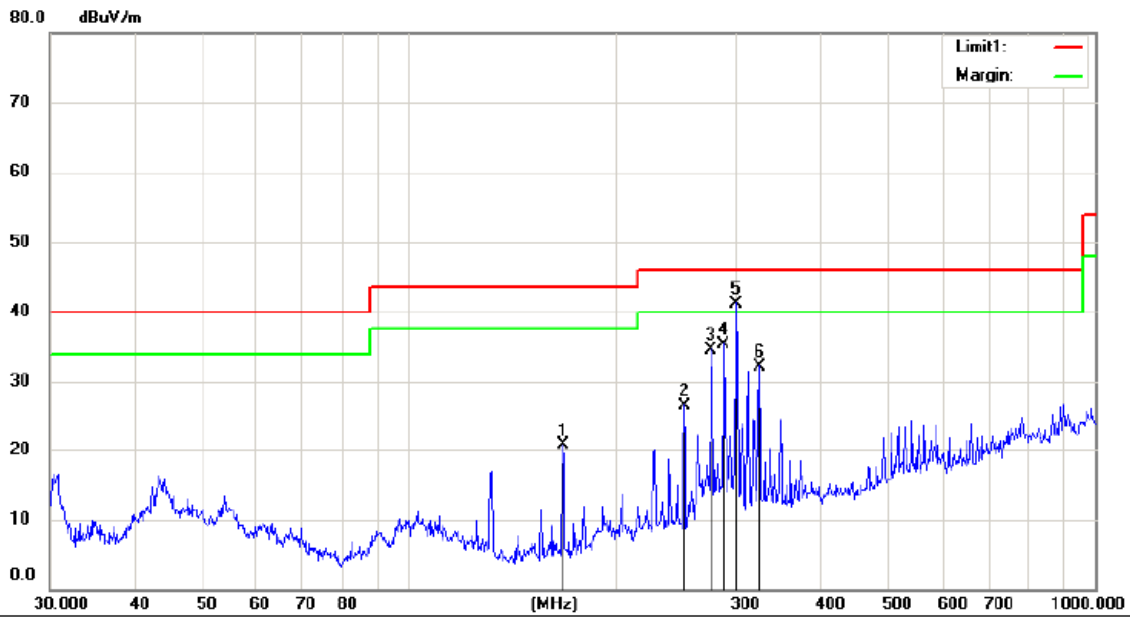

Site site #1 Polarization: **Horizontal** Temperature: 20 C  
 Limit: FCC Part15 Class B 3M Radiation Power: AC 120V/60Hz Humidity: 52 %  
 Mode:BT(GFSK,High Channel)  
 Note:

No.	Mk.	Freq.	Reading Level	Correct Factor	Measurement	Limit	Over	Antenna Height	Table Degree	Comment
		MHz	dBuV	dB	dBuV/m	dBuV/m	dB	cm	degree	
1		167.8243	46.07	-25.37	20.70	43.50	-22.80	QP		
2		252.0627	48.06	-21.46	26.60	46.00	-19.40	QP		
3		276.1235	53.95	-19.35	34.60	46.00	-11.40	QP		
4		287.9904	54.71	-19.31	35.40	46.00	-10.60	QP		
5	*	300.3672	60.15	-18.95	41.20	46.00	-4.80	QP		
6		324.4561	50.27	-18.07	32.20	46.00	-13.80	QP		

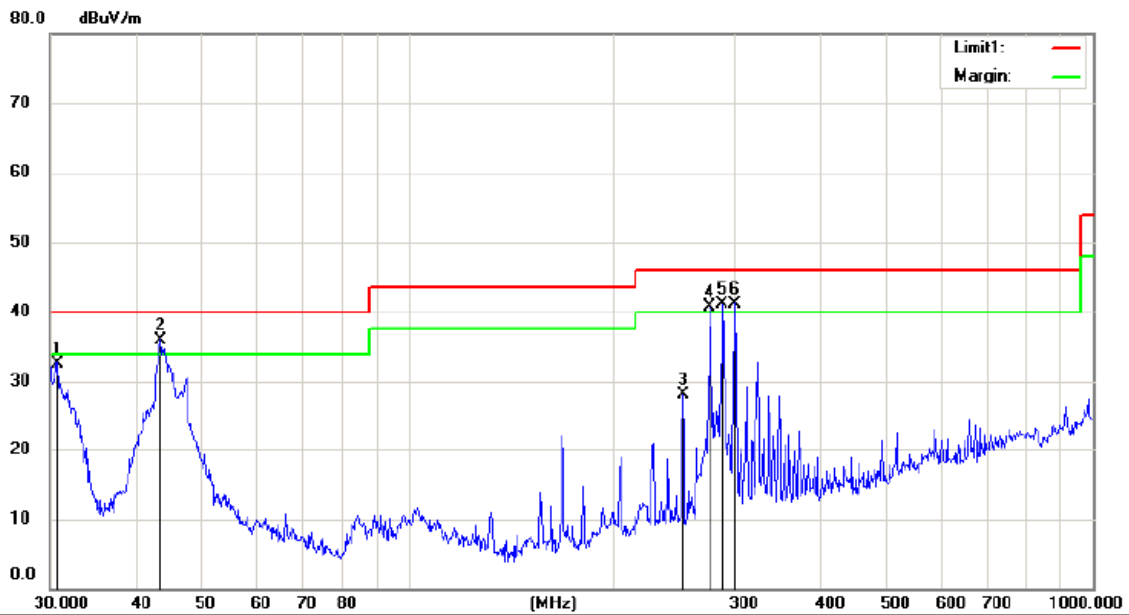

Site site #1 Polarization: **Vertical** Temperature: 20 C  
 Limit: FCC Part15 Class B 3M Radiation Power: AC 120V/60Hz Humidity: 52 %  
 Mode:BT(GFSK,High Channel)  
 Note:

No.	Mk.	Freq.	Reading Level	Correct Factor	Measurement	Limit	Over	Antenna Height	Table Degree	Comment
		MHz	dBuV	dB	dBuV/m	dBuV/m	dB	cm	degree	
1		30.7455	56.56	-23.96	32.60	40.00	-7.40			QP
2	*	43.5057	56.09	-20.09	36.00	40.00	-4.00			QP
3		252.0627	49.56	-21.46	28.10	46.00	-17.90			QP
4	!	276.1235	60.05	-19.35	40.70	46.00	-5.30			QP
5	!	287.9904	60.41	-19.31	41.10	46.00	-4.90			QP
6	!	300.3672	60.15	-18.95	41.20	46.00	-4.80			QP

**USB Mode:**

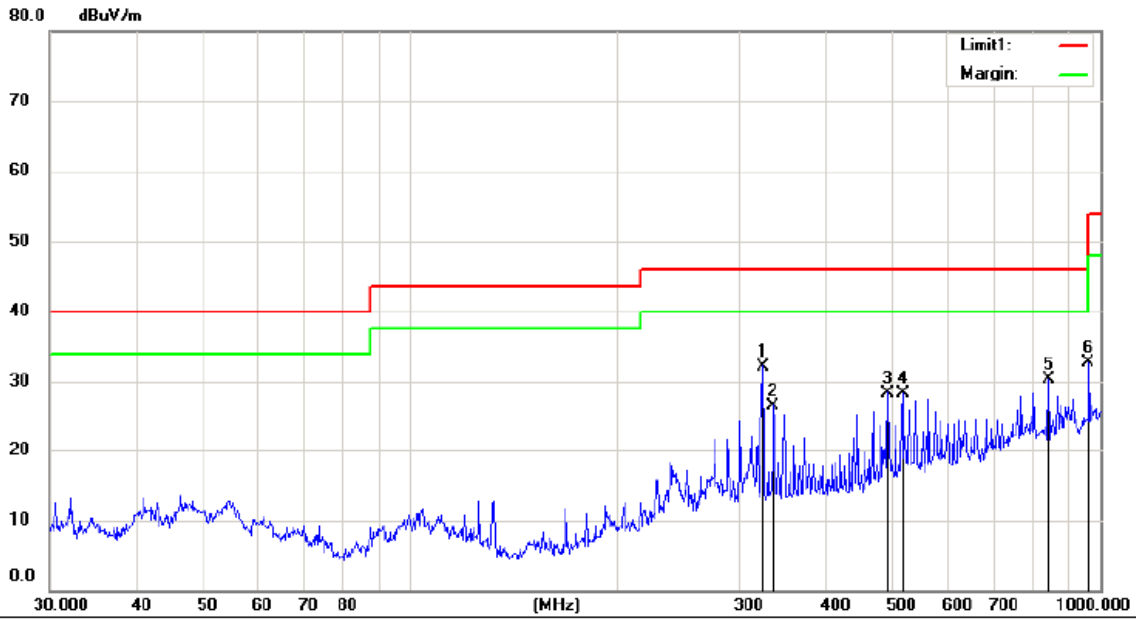

Site site #1 Polarization: **Horizontal** Temperature: 18 C  
 Limit: FCC Part15 Class B 3M Radiation Power: AC 120V/60Hz Humidity: 42 %  
 Mode:USB Mode  
 Note:

No.	Mk.	Freq. MHz	Reading Level dBuV	Correct Factor dB	Measure- ment dBuV/m	Limit dBuV/m	Over dB	Antenna Height cm	Table Degree	Detector	Comment
1	*	324.4561	50.27	-18.07	32.20	46.00	-13.80			QP	
2		336.0352	44.37	-17.77	26.60	46.00	-19.40			QP	
3		492.4685	43.35	-14.95	28.40	46.00	-17.60			QP	
4		517.2480	41.87	-13.57	28.30	46.00	-17.70			QP	
5		842.1296	39.35	-9.05	30.30	46.00	-15.70			QP	
6		962.1623	38.97	-6.27	32.70	54.00	-21.30			QP	

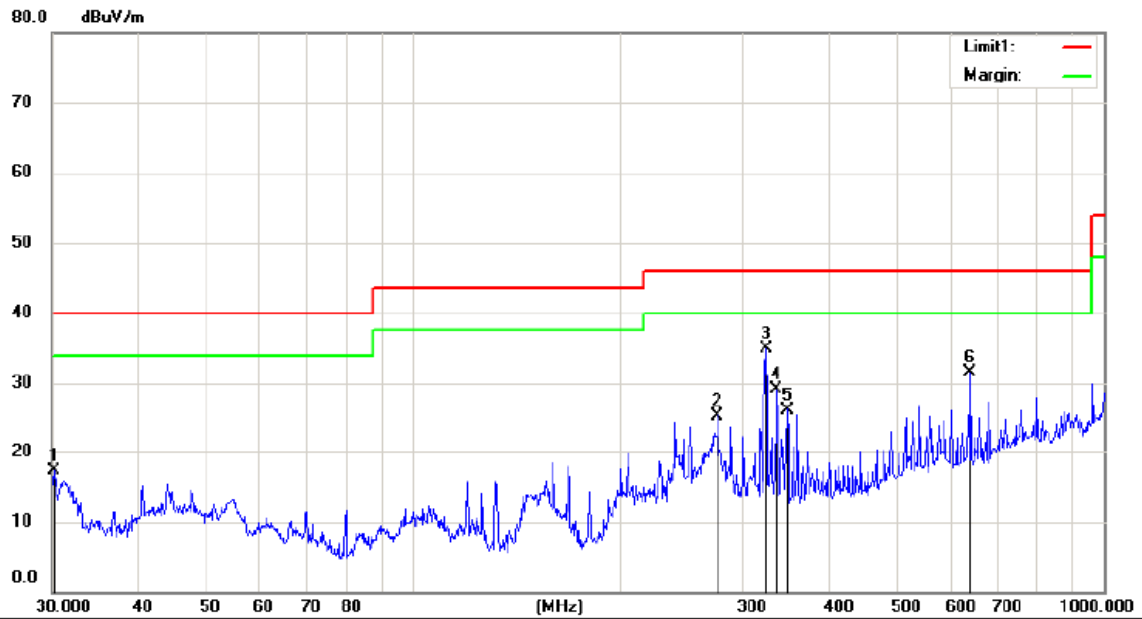

Site site #1 Polarization: *Vertical* Temperature: 18 C  
 Limit: FCC Part15 Class B 3M Radiation Power: AC 120V/60Hz Humidity: 42 %  
 Mode:USB Mode  
 Note:

No.	Mk.	Freq.	Reading Level	Correct Factor	Measurement	Limit	Over	Antenna Height	Table Degree	
		MHz	dBuV	dB	dBuV/m	dBuV/m	dB	cm	degree	Comment
1		30.2111	41.56	-24.26	17.30	40.00	-22.70			
2		276.1235	44.75	-19.35	25.40	46.00	-20.60			
3	*	324.4561	52.97	-18.07	34.90	46.00	-11.10			
4		336.0352	46.87	-17.77	29.10	46.00	-16.90			
5		348.0274	44.34	-18.14	26.20	46.00	-19.80			
6		640.6110	43.86	-12.36	31.50	46.00	-14.50			

AUX IN Mode

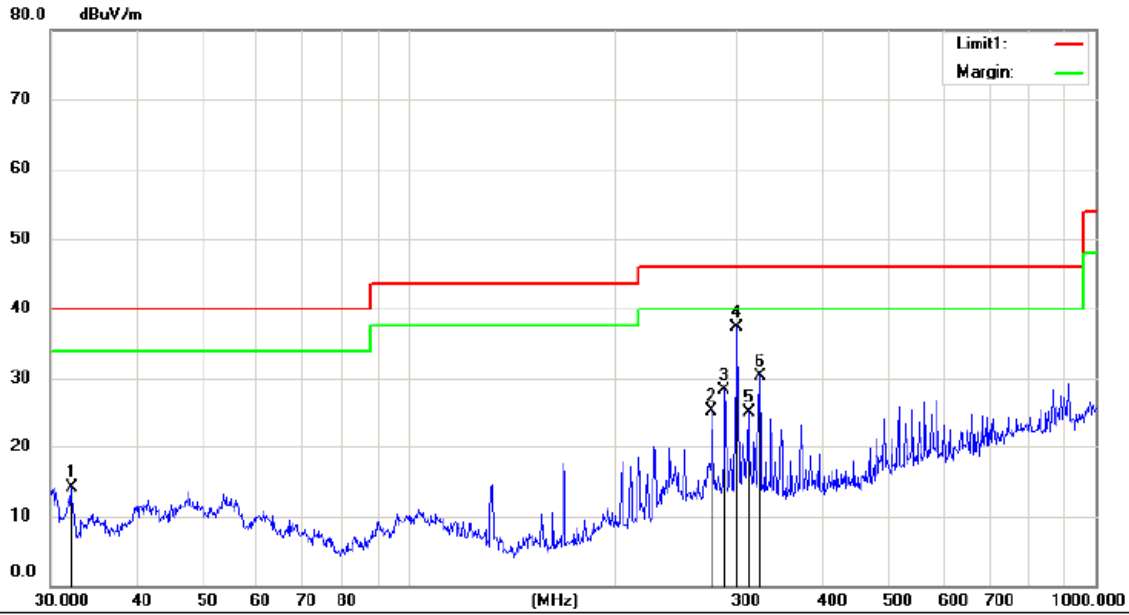

Site site #1 Polarization: *Horizontal* Temperature: 18 C  
 Limit: FCC Part15 Class B 3M Radiation Power: AC 120V/60Hz Humidity: 42 %  
 Mode:AUX IN  
 Note:

No.	Mk.	Freq.	Reading Level	Correct Factor	Measurement	Limit	Over	Antenna Height	Table Degree	
		MHz	dBuV	dB	dBuV/m	dBuV/m	dB	cm	degree	Comment
1		32.1795	37.38	-23.18	14.20	40.00	-25.80			
2		276.1235	44.75	-19.35	25.40	46.00	-20.60			
3		287.9904	47.61	-19.31	28.30	46.00	-17.70			
4	*	300.3672	56.35	-18.95	37.40	46.00	-8.60			
5		312.1794	43.84	-18.64	25.20	46.00	-20.80			
6		324.4561	48.47	-18.07	30.40	46.00	-15.60			

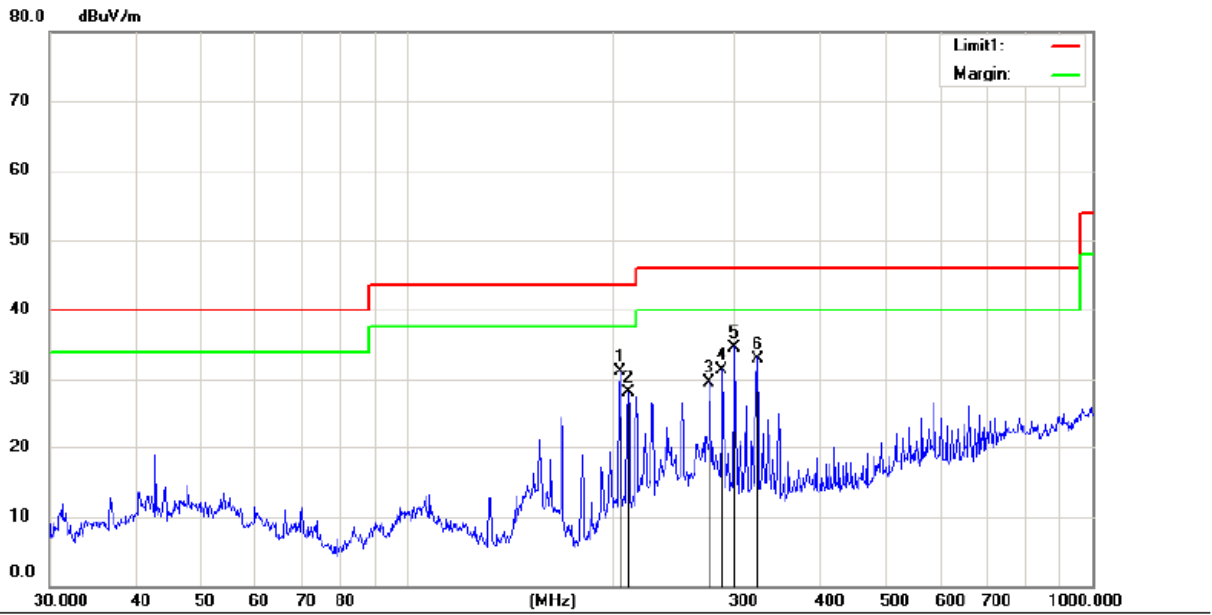

Site site #1 Polarization: **Vertical** Temperature: 18 C  
 Limit: FCC Part15 Class B 3M Radiation Power: AC 120V/60Hz Humidity: 42 %  
 Mode:AUX IN  
 Note:

No.	Mk.	Freq.	Reading Level	Correct Factor	Measurement	Limit	Over	Antenna Height	Table Degree	
		MHz	dBuV	dB	dBuV/m	dBuV/m	dB	cm	degree	Comment
1		204.2377	53.32	-22.22	31.10	43.50	-12.40			QP
2		210.0482	50.74	-22.64	28.10	43.50	-15.40			QP
3		276.1235	48.95	-19.35	29.60	46.00	-16.40			QP
4		287.9904	50.71	-19.31	31.40	46.00	-14.60			QP
5	*	300.3672	53.55	-18.95	34.60	46.00	-11.40			QP
6		324.4561	51.07	-18.07	33.00	46.00	-13.00			QP

**Above 1000MHz:**

Test Date : 04/23/2015 Temperature : 24 °C  
 Test Result: PASS Humidity : 53 %  
 Test By: KK

GFSK Mode: Low channel							
Freq. (MHz)	Ant.Pol. (H/V)	Emission Level(dBuV/m)		Limit 3m(dBuV/m)		Margin(dB)	
		PK	AV	PK	AV	PK	AV
4841.346	V	50.27	40.40	74.00	54.00	-23.73	-13.60
7184.295	V	55.07	43.60	74.00	54.00	-18.93	-10.40
7729.167	V	55.22	43.50	74.00	54.00	-18.78	-10.50
9854.167	V	60.32	46.90	74.00	54.00	-13.68	-7.10
10862.179	V	61.75	50.70	74.00	54.00	-12.25	-3.30
14376.603	V	66.78	50.50	74.00	54.00	-7.22	-3.50
4623.397	H	49.87	39.80	74.00	54.00	-24.13	-14.20
8028.846	H	57.38	45.60	74.00	54.00	-16.62	-8.40
10426.282	H	61.74	50.40	74.00	54.00	-12.26	-3.60
13940.705	H	63.50	43.80	74.00	54.00	-10.50	-10.20
14594.551	H	66.07	47.50	74.00	54.00	-7.93	-6.50
16419.872	H	65.07	44.80	74.00	54.00	-8.93	-9.20

GFSK Mode: Middle channel							
Freq. (MHz)	Ant.Pol. (H/V)	Emission Level(dBuV/m)		Limit 3m(dBuV/m)		Margin(dB)	
		PK	AV	PK	AV	PK	AV
7184.295	V	54.57	43.60	74.00	54.00	-19.43	-10.32
7729.167	V	54.72	44.20	74.00	54.00	-19.28	-9.74
10780.449	V	61.63	48.80	74.00	54.00	-12.37	-2.98
14158.654	V	64.25	48.20	74.00	54.00	-9.75	-2.76
14376.603	V	66.28	50.50	74.00	54.00	-7.72	-3.43
15820.513	V	64.72	48.00	74.00	54.00	-9.28	-5.99
4623.397	H	48.87	40.70	74.00	54.00	-25.13	-13.30
7238.782	H	55.17	45.50	74.00	54.00	-18.83	-8.50
9363.782	H	58.42	47.00	74.00	54.00	-15.58	-7.00
10426.282	H	61.24	50.30	74.00	54.00	-12.76	-3.70
14322.115	H	63.83	50.80	74.00	54.00	-10.17	-3.20
14594.551	H	65.07	50.20	74.00	54.00	-8.93	-3.80

GFSK Mode: High channel							
Freq. (MHz)	Ant.Pol. (H/V)	Emission Level(dBuV/m)		Limit 3m(dBuV/m)		Margin(dB)	
		PK	AV	PK	AV	PK	AV
3560.897	V	46.71	36.80	74.00	54.00	-27.29	-17.20
4841.346	V	49.77	37.50	74.00	54.00	-24.23	-16.50
7184.295	V	55.07	43.60	74.00	54.00	-18.93	-10.40
10862.179	V	61.25	49.60	74.00	54.00	-12.75	-4.40
14376.603	V	66.78	50.40	74.00	54.00	-7.22	-3.60
16556.090	V	64.88	48.30	74.00	54.00	-9.12	-5.70
5032.051	H	50.18	40.60	74.00	54.00	-23.82	-13.40
7238.782	H	55.67	44.50	74.00	54.00	-18.33	-9.50
8028.846	H	57.38	45.20	74.00	54.00	-16.62	-8.80
9363.782	H	58.92	47.90	74.00	54.00	-15.08	-6.10
10426.282	H	61.74	50.30	74.00	54.00	-12.26	-3.70
14594.551	H	66.07	50.20	74.00	54.00	-7.93	-3.80



Test Date : 04/23/2015  
Test Result: PASS  
Test By: KK

Temperature : 24 °C  
Humidity : 53 %

π/4-DQPSK: Low channel							
Freq. (MHz)	Ant.Pol. (H/V)	Emission Level(dBuV/m)		Limit 3m(dBuV/m)		Margin(dB)	
		PK	AV	PK	AV	PK	AV
3560.897	V	46.21	35.80	74.00	54.00	-27.79	-18.20
4841.346	V	49.77	38.20	74.00	54.00	-24.23	-15.80
7729.167	V	55.22	43.30	74.00	54.00	-18.78	-10.70
9282.051	V	59.02	49.00	74.00	54.00	-14.98	-5.00
10862.179	V	61.25	49.70	74.00	54.00	-12.75	-4.30
14376.603	V	66.28	49.70	74.00	54.00	-7.72	-4.30
4623.397	H	49.37	38.40	74.00	54.00	-24.63	-15.60
7238.782	H	55.17	44.70	74.00	54.00	-18.83	-9.30
8028.846	H	56.88	45.30	74.00	54.00	-17.12	-8.70
10426.282	H	61.74	50.10	74.00	54.00	-12.26	-3.90
10753.205	H	60.83	48.60	74.00	54.00	-13.17	-5.40
14431.090	H	64.61	50.50	74.00	54.00	-9.39	-3.50

π/4-DQPSK: Middle channel							
Freq. (MHz)	Ant.Pol. (H/V)	Emission Level(dBuV/m)		Limit 3m(dBuV/m)		Margin(dB)	
		PK	AV	PK	AV	PK	AV
3560.897	V	45.21	36.80	74.00	54.00	-28.79	-17.20
4841.346	V	49.27	37.20	74.00	54.00	-24.73	-16.80
7184.295	V	54.07	41.00	74.00	54.00	-19.93	-13.00
9690.705	V	59.42	48.40	74.00	54.00	-14.58	-5.60
11080.128	V	60.34	49.70	74.00	54.00	-13.66	-4.30
14376.603	V	66.28	50.50	74.00	54.00	-7.72	-3.50
5032.051	H	49.18	40.60	74.00	54.00	-24.82	-13.40
8028.846	H	56.88	44.40	74.00	54.00	-17.12	-9.60
10426.282	H	61.24	50.60	74.00	54.00	-12.76	-3.40
11325.32	H	60.36	48.30	74.00	54.00	-13.64	-5.70
14594.551	H	65.07	49.10	74.00	54.00	-8.93	-4.90
15956.731	H	64.26	45.90	74.00	54.00	-9.74	-8.10

π/4-DQPSK: High channel							
Freq. (MHz)	Ant.Pol. (H/V)	Emission Level(dBuV/m)		Limit 3m(dBuV/m)		Margin(dB)	
		PK	AV	PK	AV	PK	AV
4841.346	V	49.27	37.20	74.00	54.00	-24.73	-16.80
7184.295	V	54.07	41.80	74.00	54.00	-19.93	-12.20
7729.167	V	54.72	44.10	74.00	54.00	-19.28	-9.90
9690.705	V	59.42	48.40	74.00	54.00	-14.58	-5.60
11080.128	V	60.34	49.70	74.00	54.00	-13.66	-4.30
14376.603	V	65.78	50.80	74.00	54.00	-8.22	-3.20
5032.051	H	49.18	40.60	74.00	54.00	-24.82	-13.40
7157.051	H	55.05	44.50	74.00	54.00	-18.95	-9.50
8600.961	H	55.78	46.50	74.00	54.00	-18.22	-7.50
10426.282	H	61.24	50.60	74.00	54.00	-12.76	-3.40
11325.32	H	60.36	48.30	74.00	54.00	-13.64	-5.70
14594.551	H	65.07	49.10	74.00	54.00	-8.93	-4.90

Test Date : 04/23/2015  
Test Result: PASS  
Test By: ZHL

Temperature : 24 °C  
Humidity : 53 %

8DPSK: Low channel							
Freq. (MHz)	Ant.Pol. (H/V)	Emission Level(dBuV/m)		Limit 3m(dBuV/m)		Margin(dB)	
		PK	AV	PK	AV	PK	AV
4434.000	V	42.72	35.20	74.00	54.00	-31.28	-18.80
6729.000	V	45.10	36.50	74.00	54.00	-28.9	-17.50
8480.000	V	47.87	36.80	74.00	54.00	-26.13	-17.20
9602.000	V	48.03	37.60	74.00	54.00	-25.97	-16.40
12152.000	V	47.93	37.20	74.00	54.00	-26.07	-16.80
14549.000	V	50.14	38.50	74.00	54.00	-23.86	-15.50
4587.000	H	42.81	34.20	74.00	54.00	-31.19	-19.80
6321.000	H	45.17	36.20	74.00	54.00	-28.83	-17.80
8378.000	H	47.30	37.40	74.00	54.00	-26.7	-16.60
9636.000	H	47.81	37.50	74.00	54.00	-26.19	-16.50
11659.000	H	47.67	37.60	74.00	54.00	-26.33	-16.40
14447.000	H	50.61	38.50	74.00	54.00	-23.39	-15.50

8DPSK: Middle channel							
Freq. (MHz)	Ant.Pol. (H/V)	Emission Level(dBuV/m)		Limit 3m(dBuV/m)		Margin(dB)	
		PK	AV	PK	AV	PK	AV
1289.000	V	37.64	29.50	74.00	54.00	-36.36	-24.50
5046.000	V	43.95	36.90	74.00	54.00	-30.05	-17.10
8514.000	V	48.18	37.30	74.00	54.00	-25.82	-16.70
9670.000	V	47.91	36.90	74.00	54.00	-26.09	-17.10
14379.000	V	51.32	37.60	74.00	54.00	-22.68	-16.40
15807.000	V	51.10	38.50	74.00	54.00	-22.9	-15.50
5029.000	H	44.35	36.00	74.00	54.00	-29.65	-18.00
6542.000	H	46.08	37.20	74.00	54.00	-27.92	-16.80
8446.000	H	46.98	36.90	74.00	54.00	-27.02	-17.10
9585.000	H	48.00	37.60	74.00	54.00	-26	-16.40
11676.000	H	48.63	37.50	74.00	54.00	-25.37	-16.50
15229.000	H	50.66	38.50	74.00	54.00	-23.34	-15.50

8DPSK: High channel							
Freq. (MHz)	Ant.Pol. (H/V)	Emission Level(dBuV/m)		Limit 3m(dBuV/m)		Margin(dB)	
		PK	AV	PK	AV	PK	AV
2428.000	V	38.32	30.20	74.00	54.00	-35.68	-23.80
4485.000	V	43.51	36.50	74.00	54.00	-30.49	-17.50
8463.000	V	47.09	37.20	74.00	54.00	-26.91	-16.80
9551.000	V	49.24	37.60	74.00	54.00	-24.76	-16.40
11523.000	V	47.76	38.00	74.00	54.00	-26.24	-16.00
13767.000	V	49.36	38.20	74.00	54.00	-24.64	-15.80
4434.000	H	44.26	35.20	74.00	54.00	-29.74	-18.80
6882.000	H	46.11	36.90	74.00	54.00	-27.89	-17.10
8259.000	H	46.98	36.80	74.00	54.00	-27.02	-17.20
9517.000	H	48.47	37.50	74.00	54.00	-25.53	-16.50
12169.000	H	47.63	37.60	74.00	54.00	-26.37	-16.40
14532.000	H	50.49	38.20	74.00	54.00	-23.51	-15.80

Test Date : 04/23/2015  
 Test Result: PASS  
 Test By: KK

Temperature : 23 °C  
 Humidity : 56%

USB Playing mode							
Freq. (MHz)	Ant.Pol. (H/V)	Emission Level(dBuV/m)		Limit 3m(dBuV/m)		Margin(dB)	
		PK	AV	PK	AV	PK	AV
1718	V	52.63	35.90	74.00	54.00	-21.37	-18.10
2437	V	48.83	30.50	74.00	54.00	-25.17	-23.50
3306	V	44.26	32.10	74.00	54.00	-29.74	-21.90
4616	V	52.56	36.10	74.00	54.00	-21.44	-17.90
5293	V	52.34	36.40	74.00	54.00	-21.66	-17.60
5753	V	51.92	38.30	74.00	54.00	-22.08	-15.70
1717	H	54.27	37.90	74.00	54.00	-19.73	-16.10
2436	H	52.79	36.20	74.00	54.00	-21.21	-17.80
3673	H	44.54	31.50	74.00	54.00	-29.46	-22.50
4586	H	51.32	35.80	74.00	54.00	-22.68	-18.20
4854	H	51.63	37.40	74.00	54.00	-22.37	-16.60
5695	H	54.37	39.90	74.00	54.00	-19.63	-14.10

Audio input mode:							
Freq. (MHz)	Ant.Pol. (H/V)	Emission Level(dBuV/m)		Limit 3m(dBuV/m)		Margin(dB)	
		PK	AV	PK	AV	PK	AV
1436	V	45.73	35.40	74.00	54.00	-28.27	-18.60
1565	V	46.09	34.20	74.00	54.00	-27.91	-19.80
2468	V	43.84	35.90	74.00	54.00	-30.16	-18.10
4574	V	50.75	41.50	74.00	54.00	-23.25	-12.50
4925	V	50.87	41.50	74.00	54.00	-23.13	-12.50
5783	V	52.34	43.70	74.00	54.00	-21.66	-10.30
1437	H	42.67	33.80	74.00	54.00	-31.33	-20.20
1942	H	43.55	34.80	74.00	54.00	-30.45	-19.20
2418	H	43.34	35.50	74.00	54.00	-30.66	-18.50
3934	H	47.05	37.50	74.00	54.00	-26.95	-16.50
5086	H	51.28	41.40	74.00	54.00	-22.72	-12.60
5764	H	53.96	42.80	74.00	54.00	-20.04	-11.20

## 6. Channel Separation Test

### 6.1 Measurement Procedure

The EUT was operating in hopping mode or could be controlled its channel. Print out the test result from the spectrum by hard copy function.

### 6.2 Test SET-UP (Block Diagram of Configuration)

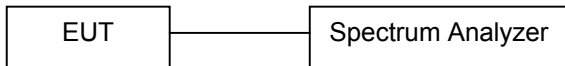

### 6.3 Measurement Equipment Used

Name of Equipment	Manufacturer	Model	Serial Number	Last Cal.	CAL DUE.
Spectrum Analyzer	Rohde & Schwarz	ESCI	10017	08/01/2014	08/01/2015

### 6.4 Measurement Results

The following table is the setting of spectrum analyzer.

Attenuation	Auto
RB	100KHz
VB	300KHz
Detector	Peak
Trace	Max hold

Refer to attached data chart.

Spectrum Detector:	PK	Test Date :	04/15/2015
Test By:	Kuki	Temperature :	21 °C
Test Result:	PASS	Humidity :	55 %

#### GFSK Mode:

Test Channel	Channel frequency (MHz)	Separation Read Value (kHz)	Separation Limit 20dB Down BW(kHz)
Low Channel	2402	1000.00	834
Adjacency Channel	2403		
Middle channel	2441	1000.00	828
Adjacency Channel	2440		
High Channel	2480	1000.00	834
Adjacency Channel	2479		

**$\pi/4$ -DQPSK Mode**

Test Channel	Channel frequency (MHz)	Separation Read Value (kHz)	Separation Limit 2/3 20dB Down BW(kHz)
Low Channel	2402	1000.00	740
Adjacency Chanel	2403		
Middle channel	2441	1000.00	744
Adjacency Chanel	2440		
High Channel	2480	1000.00	744
Adjacency Chanel	2479		

**8DPSK Mode:**

Test Channel	Channel frequency (MHz)	Separation Read Value (kHz)	Separation Limit 2/3 20dB Down BW(kHz)
Low Channel	2402	1000.00	780
Adjacency Chanel	2403		
Middle channel	2441	1000.00	776
Adjacency Chanel	2440		
High Channel	2480	1000.00	780
Adjacency Chanel	2479		

**GFSK Mode: Low channel**

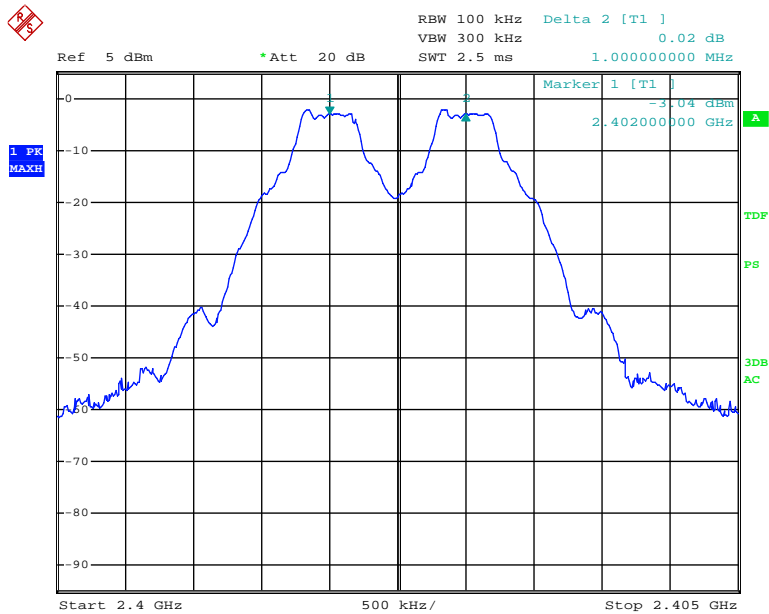

Date: 15.APR.2015 07:08:04

GFSK Mode: Middle channel

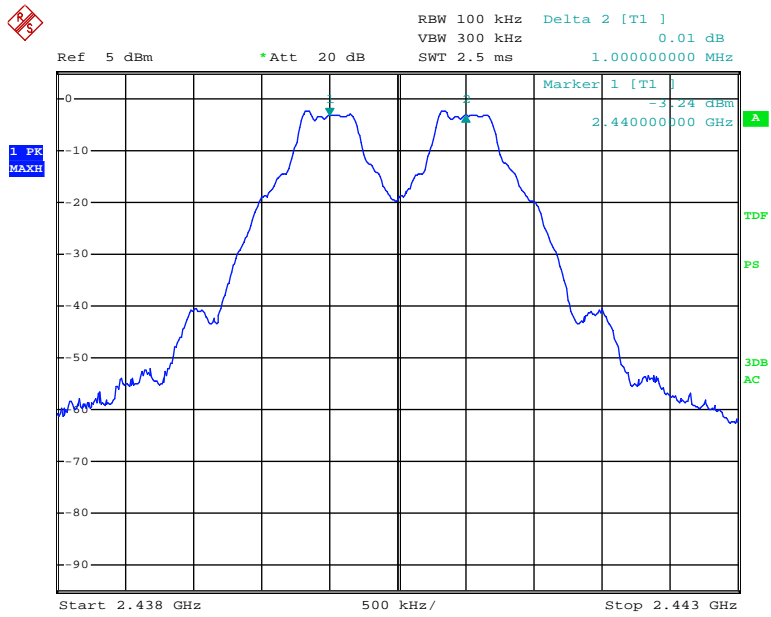

Date: 15.APR.2015 07:09:46

GFSK Mode: High channel

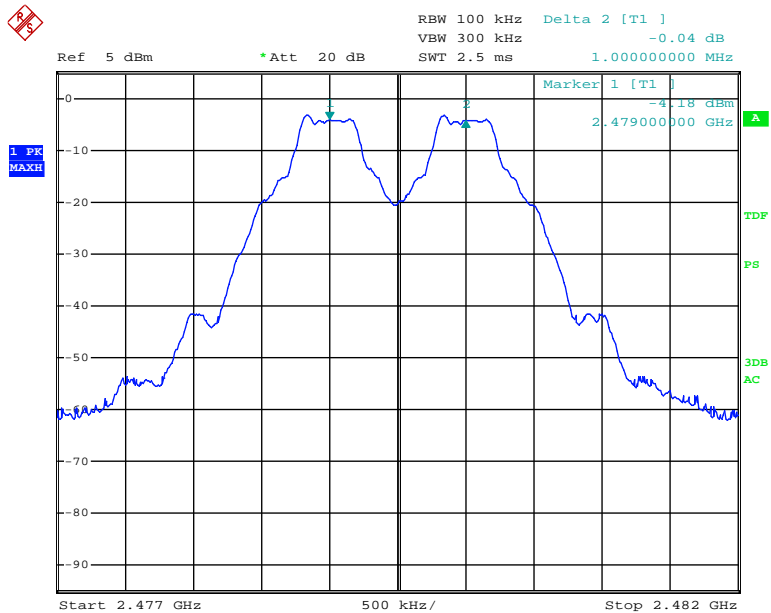

Date: 15.APR.2015 07:12:14

$\pi/4$ -DQPSK Mode: Low channel

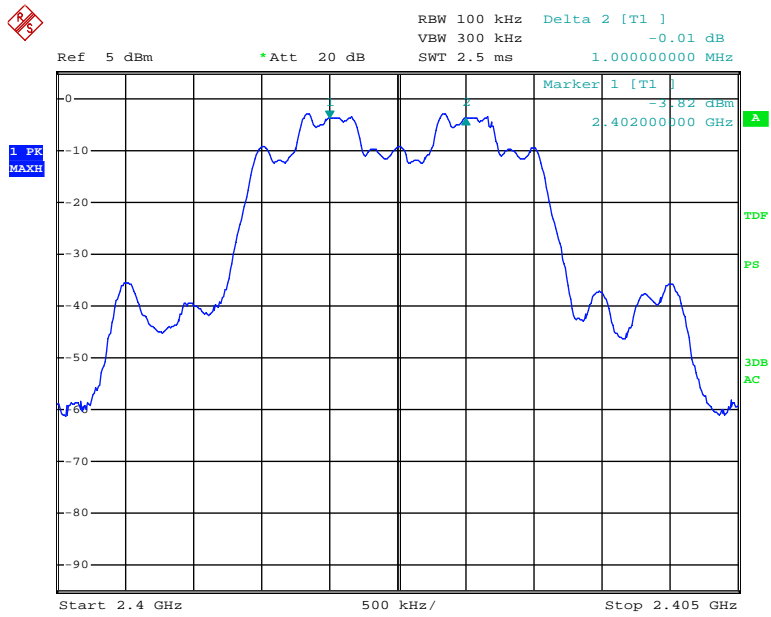

Date: 15.APR.2015 07:14:27

$\pi/4$ -DQPSK Mode: Middle channel

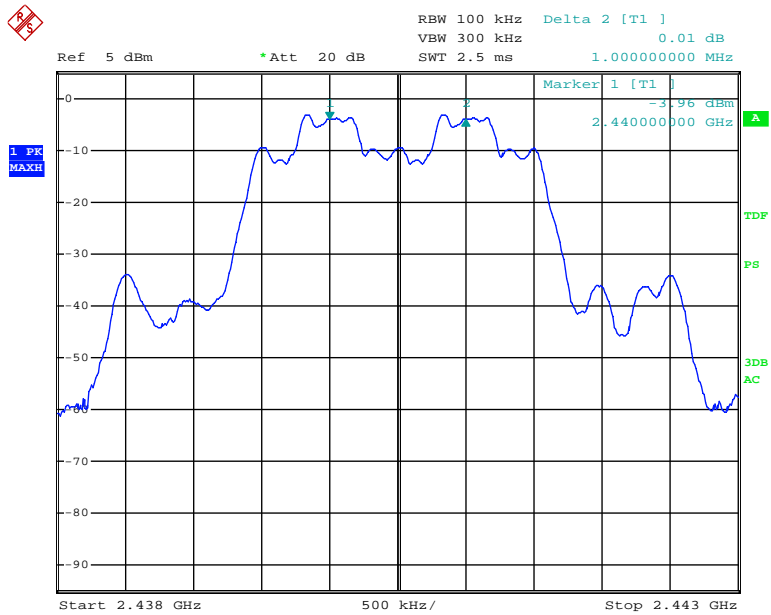

Date: 15.APR.2015 07:16:29

$\pi/4$ -DQPSK Mode: High channel

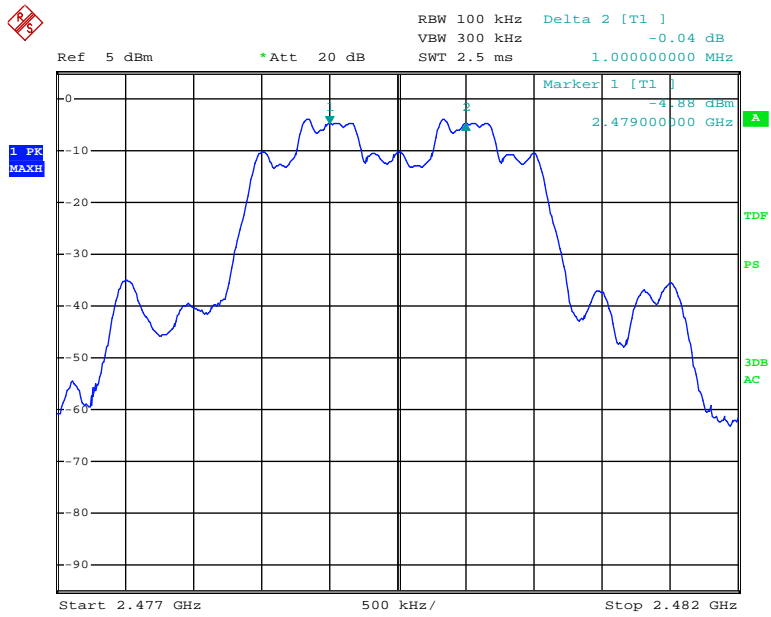

Date: 15.APR.2015 07:18:00

8DPSK Mode: Low channel

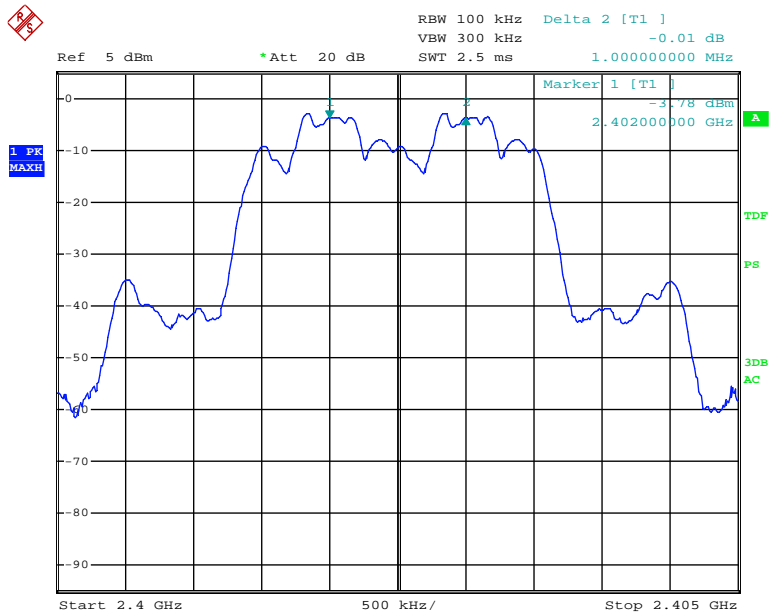

Date: 15.APR.2015 07:19:55



8DPSK Mode: Middle channel

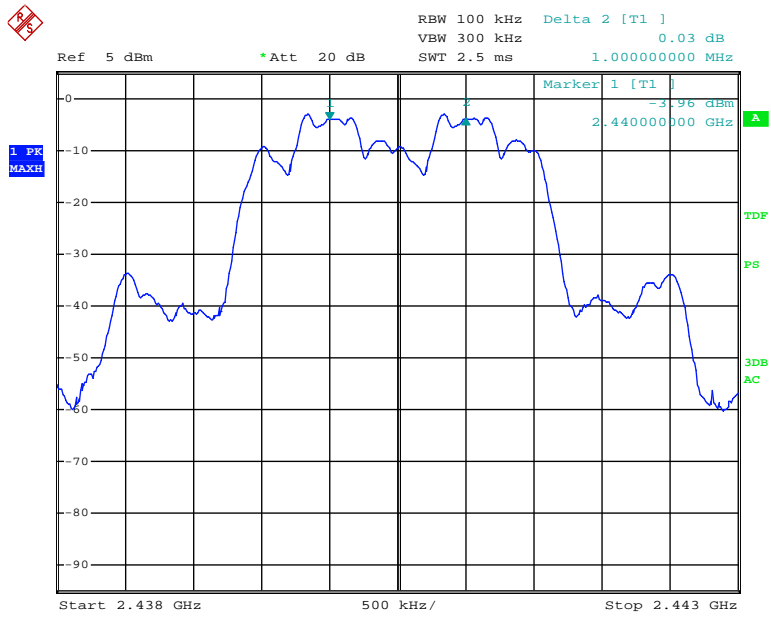

Date: 15.APR.2015 07:22:03

8DPSK Mode: High channel

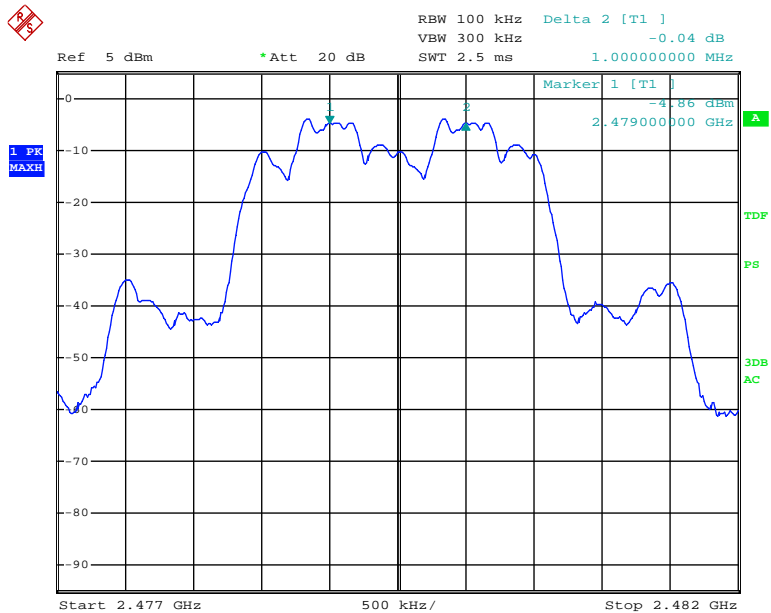

Date: 15.APR.2015 07:23:55

## 7. Bandwidth Test

### 7.1 Measurement Procedure

The EUT was operating in hopping mode or could be controlled its channel. Print out the test result from the spectrum by hard copy function.

### 7.2 Test SET-UP (Block Diagram of Configuration)

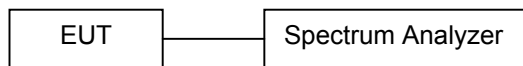

### 7.3 Measurement Equipment Used

Name of Equipment	Manufacturer	Model	Serial Number	Last Cal.	CAL DUE.
Spectrum Analyzer	Rohde & Schwarz	ESCI	10017	08/01/2014	08/01/2015

### 7.4 Measurement Results

The following table is the setting of spectrum analyzer.

Attenuation	Auto
SPAN	3MHz
RB	30KHz
VB	100KHz
Detector	Peak
Trace	Max hold

20dB Bandwidth test data Chart:

Refer to attached data chart.

Spectrum Detector:	PK	Test Date:	03/23/2015
Test By:	Kuki	Temperature:	21 °C
Test Result:	N/A	Humidity:	55 %

GFSK Mode:

Channel number	Channel frequency (MHz)	20dB Down BW(kHz)
Low channel	2402	834
Middle channel	2441	828
High channel	2480	834

$\pi/4$ -DQPSK Mode:

Channel number	Channel frequency (MHz)	20dB Down BW(kHz)
Low channel	2402	1110
Middle channel	2441	1116
High channel	2480	1116

8DPSK Mode:

Channel number	Channel frequency (MHz)	20dB Down BW(kHz)
Low channel	2402	1170
Middle channel	2441	1164
High channel	2480	1170

GFSK Mode: Low channel

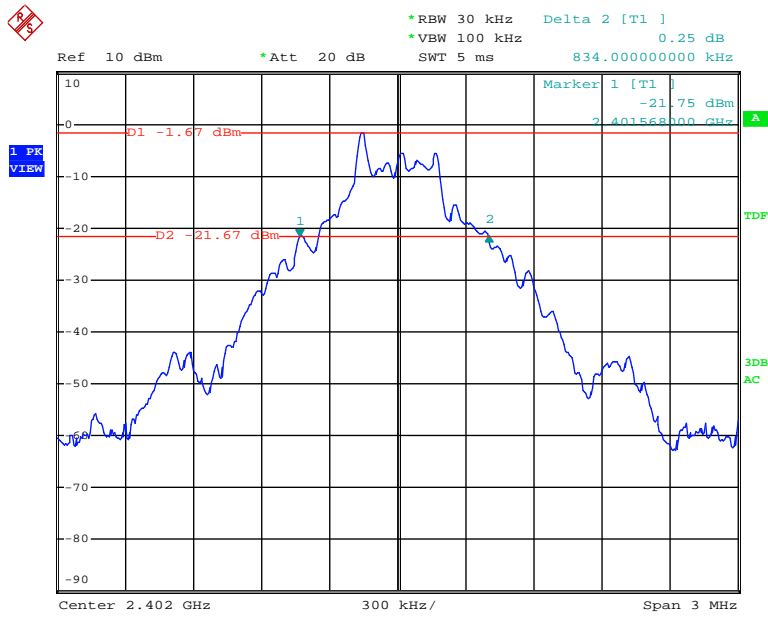

Date: 23.MAR.2015 05:25:55

GFSK Mode: Middle channel

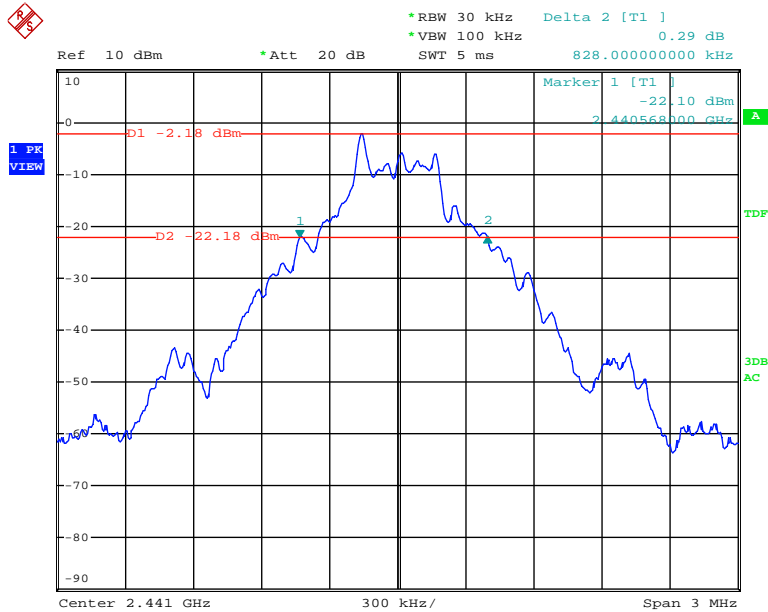

Date: 23.MAR.2015 05:26:59

GFSK Mode: High channel

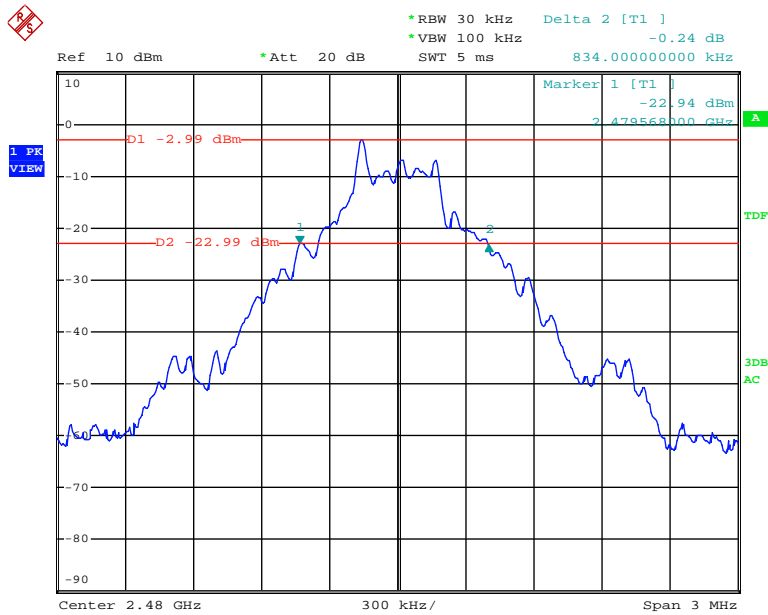

Date: 23.MAR.2015 05:28:11

$\pi/4$ -DQPSK Mode: Low channel

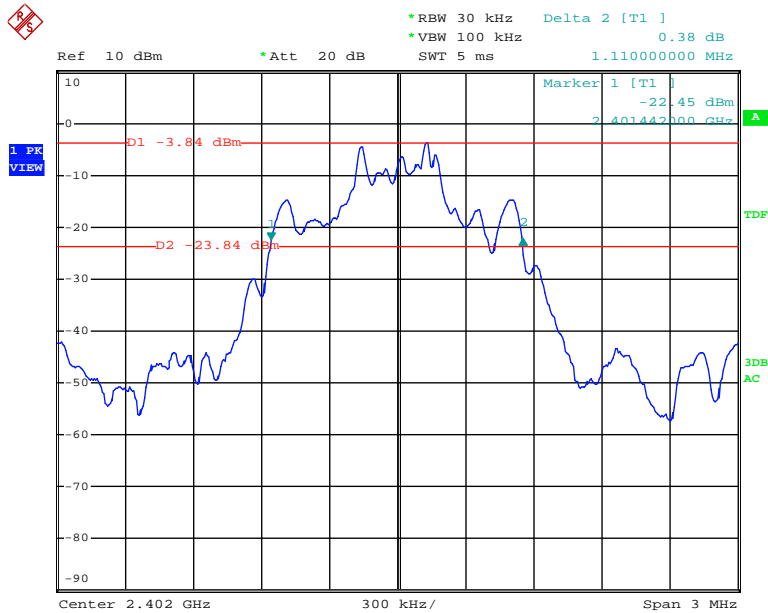

Date: 23.MAR.2015 05:30:40

$\pi/4$ -DQPSK Mode: Middle channel

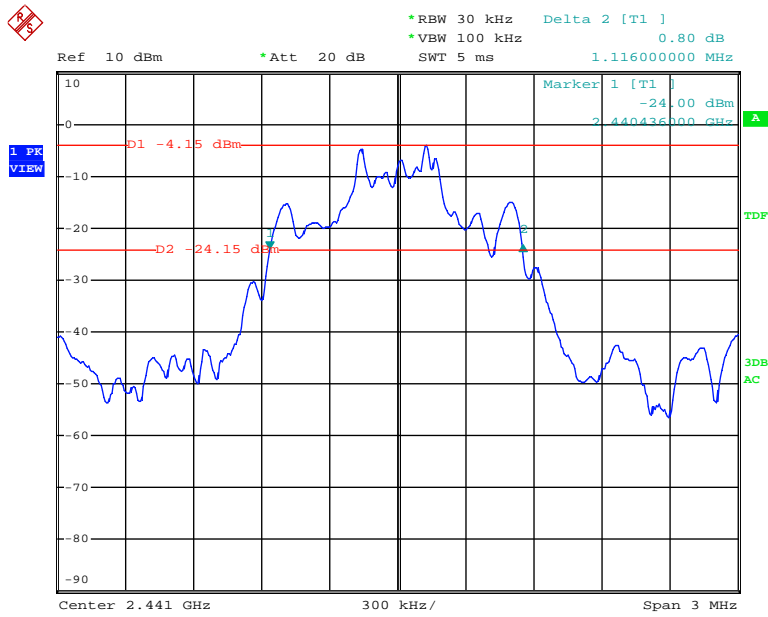

Date: 23.MAR.2015 05:31:51

$\pi/4$ -DQPSK Mode: High channel

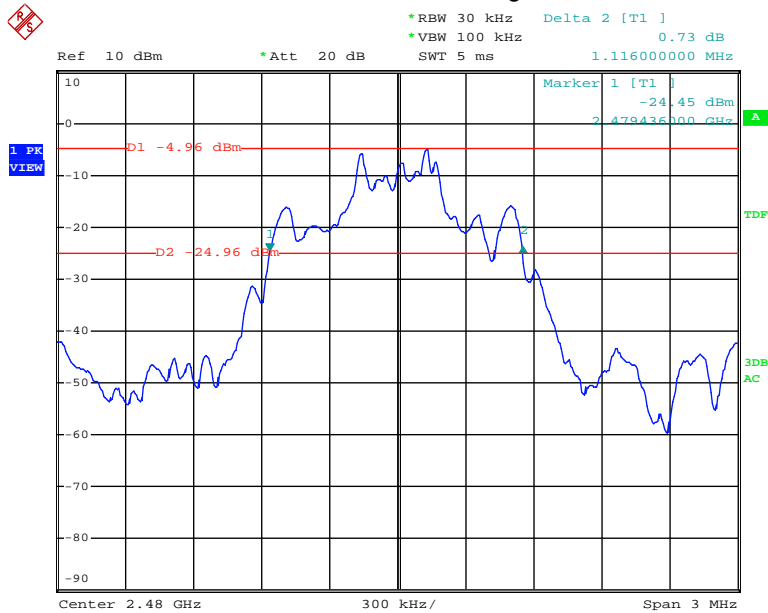

Date: 23.MAR.2015 05:33:58

### 8DPSK Mode: Low channel

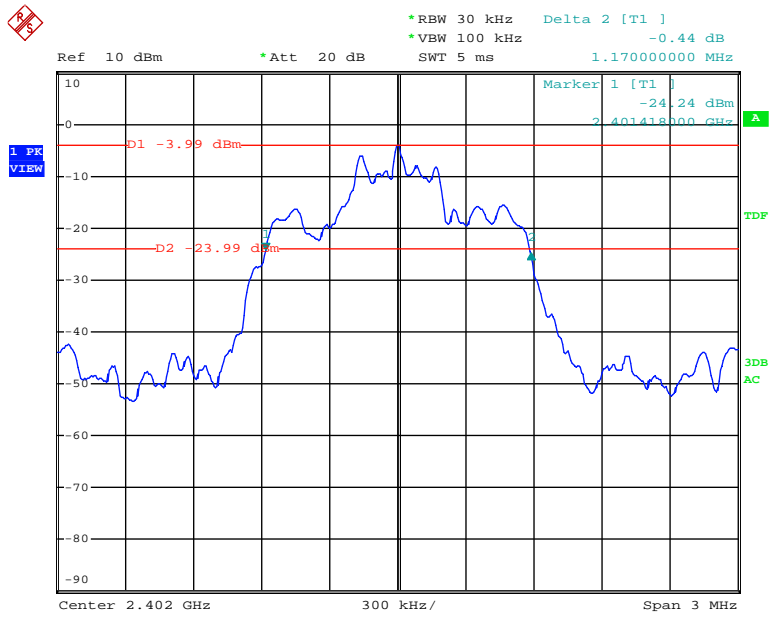

Date: 23.MAR.2015 05:36:52

### 8DPSK Mode: Middle channel

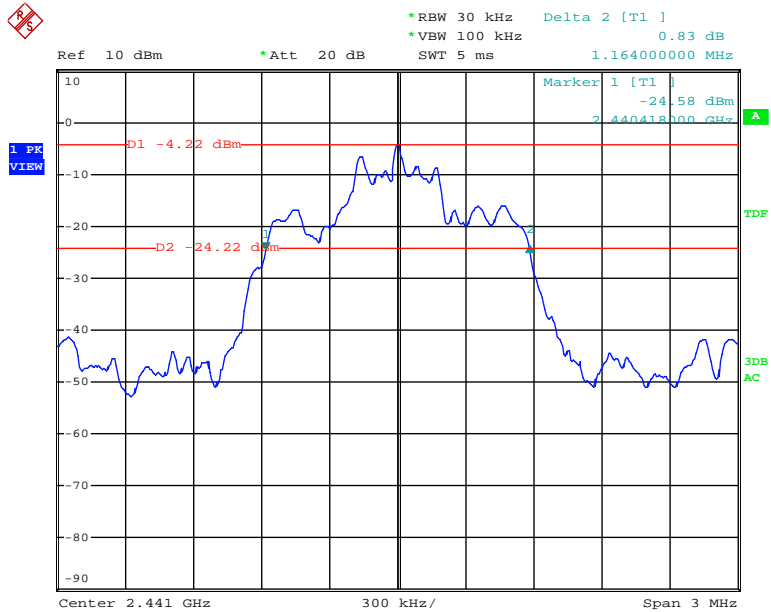

Date: 23.MAR.2015 05:38:38

8DPSK Mode: High channel

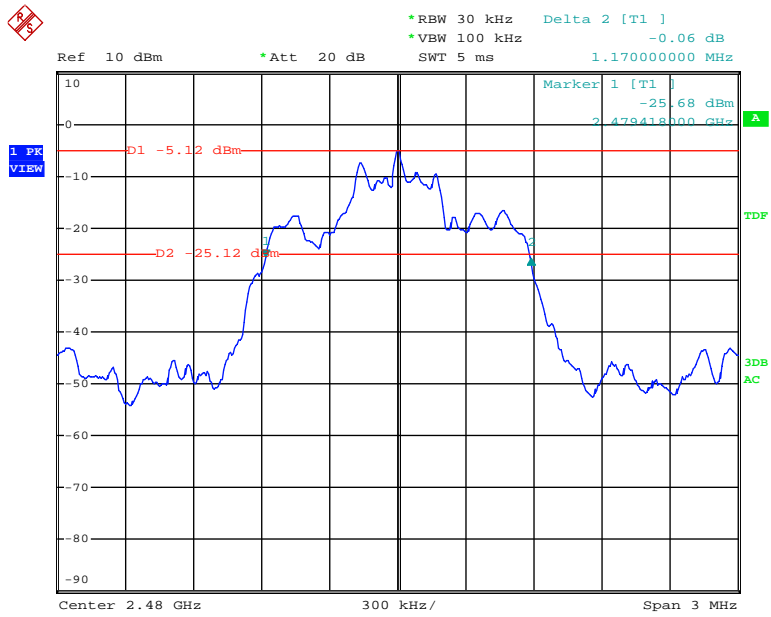

Date: 23.MAR.2015 05:39:35



## 8. Quantity of Hopping Channel Test

### 8.1 Measurement Procedure

The EUT was operating in hopping mode or could be controlled its channel. Print out the test result from the spectrum by hard copy function.

### 8.2 Test SET-UP (Block Diagram of Configuration)

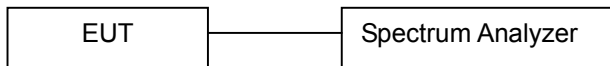

### 8.3 Measurement Equipment Used

Name of Equipment	Manufacturer	Model	Serial Number	Last Cal.	CAL DUE.
Spectrum Analyzer	Rohde & Schwarz	ESCI	10017	08/01/2014	08/01/2015

### 8.4 Measurement Results

Refer to attached data chart.

Spectrum Detector:	PK	Test Date :	03/24/2015
Test By:	Jary	Temperature :	21 °C
Test Result:	Pass	Humidity :	55 %

GFSK Mode,  $\pi/4$ -DQPSK Mode, 8DPSK Mode:

Hopping Channel Frequency Range	Quantity of Hopping Channel	Quantity of Hopping Channel limit
2402-2480	79	>15

**GFSK Mode**

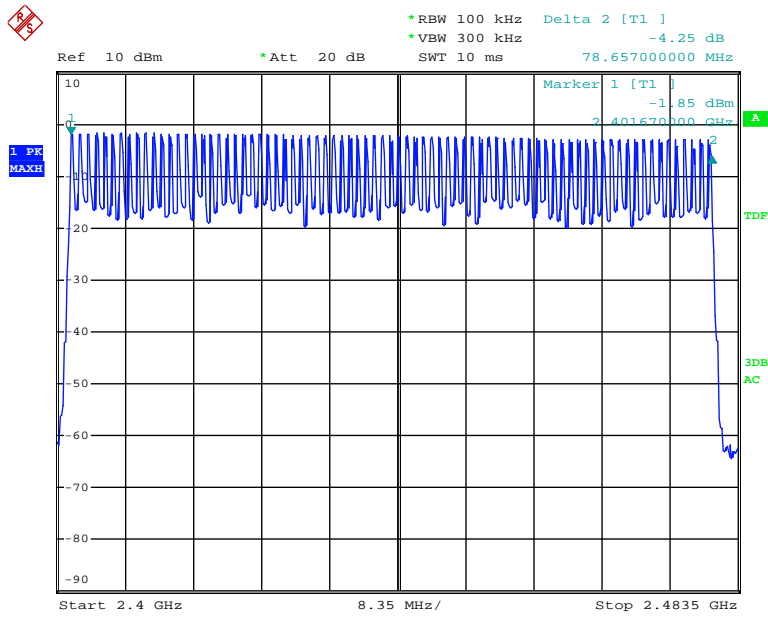

Date: 24.MAR.2015 05:34:12

**$\pi/4$ -DQPSK Mode**

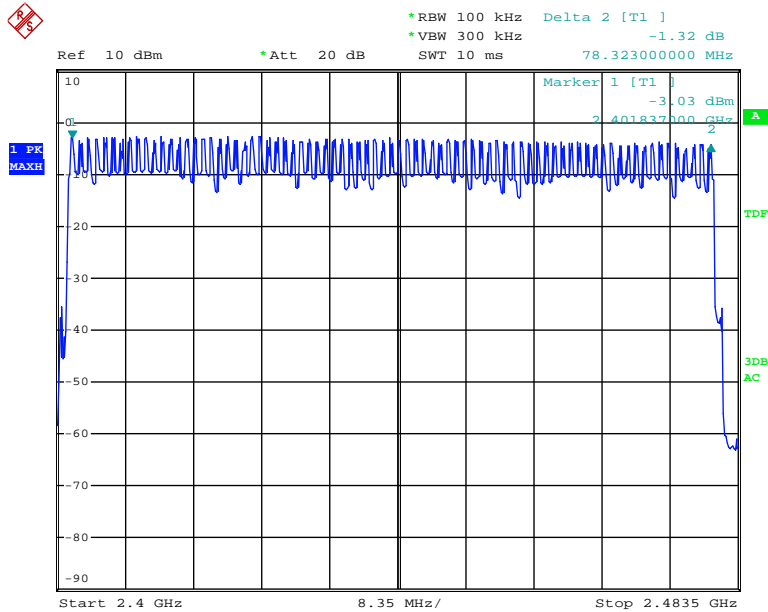

Date: 24.MAR.2015 05:40:08

### 8DPSK Mode

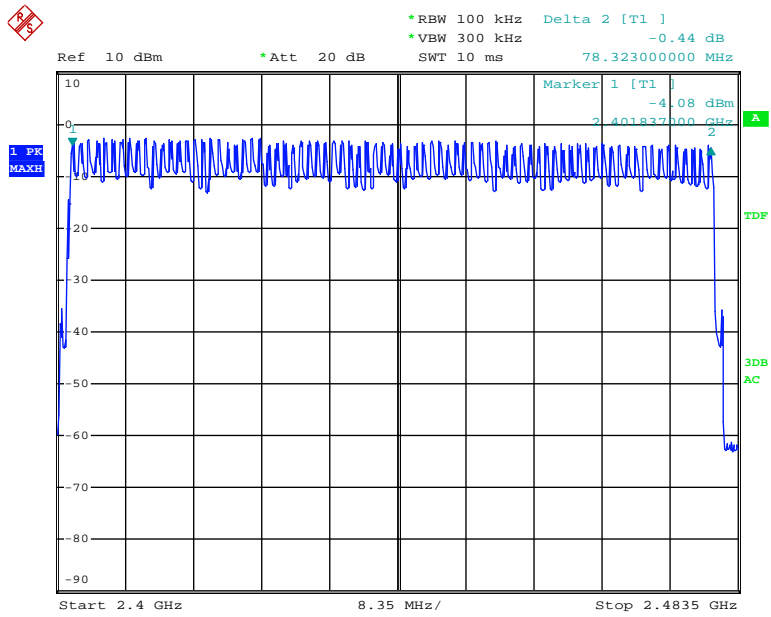

Date: 24.MAR.2015 05:46:21

## 9. Time of Occupancy (Dwell Time) Test

### 9.1 Measurement Procedure

- a. Check the calibration of the measuring instrument(SA) using either an internal calibrator or a known signal from an external generator.
- b. Turn on the EUT and connect its antenna terminal to measurement via a low loss cable. Then set it to any one measured frequency within its operating range and make sure the instrument is operated in its linear range.
- c. Adjust the center frequency of SA on any frequency be measured and set SA to zero span mode. And then, set RBW and VBW of spectrum analyzer to proper value.
- d. Measure the time duration of one transmission on the measured frequency. And then plot the result with time difference of this time duration.
- e. Repeat above procedures until all different time-slot modes have been completed.

### 9.2 Test SET-UP (Block Diagram of Configuration)

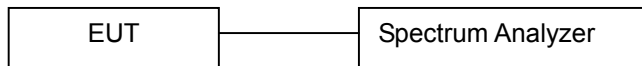

### 9.3 Measurement Equipment Used

Name of Equipment	Manufacturer	Model	Serial Number	Last Cal.	CAL DUE.
Spectrum Analyzer	Rohde & Schwarz	ESCI	10017	08/01/2014	08/01/2015

### 9.4 Measurement Results

Refer to attached data chart.

Spectrum Detector: PK  
 Test By: Kuki  
 Test Result: PASS

Test Date : 04/15/2015  
 Temperature : 21 °C  
 Humidity : 55 %

Mode	Channel	Pulse Width (ms)	Dwell Time (ms)	Limit (ms)	Result
GFSK Mode					
DH1	Low channel	0.370	118.4	400	Pass
	Middle channel	0.370	118.4	400	Pass
	High channel	0.375	120.0	400	Pass
	Note: Dwell time=Pulse Time (ms) × (1600 ÷ 2 ÷ 79) ×31.6 Second				
DH3	Low channel	1.630	260.8	400	Pass
	Middle channel	1.630	260.8	400	Pass
	High channel	1.630	260.8	400	Pass
	Note: Dwell time=Pulse Time (ms) × (1600 ÷ 4 ÷ 79) ×31.6 Second				
DH5	Low channel	2.880	307.2	400	Pass
	Middle channel	2.896	308.9	400	Pass
	High channel	2.880	307.2	400	Pass
	Note: Dwell time=Pulse Time (ms) × (1600 ÷ 6 ÷ 79) ×31.6 Second				
π/4-DPSK Mode					
2DH1	Low channel	0.380	121.6	400	Pass
	Middle channel	0.380	121.6	400	Pass
	High channel	0.380	121.6	400	Pass
	Note: Dwell time=Pulse Time (ms) × (1600 ÷ 2 ÷ 79) ×31.6 Second				
2DH3	Low channel	1.640	262.4	400	Pass
	Middle channel	1.630	260.8	400	Pass
	High channel	1.630	260.8	400	Pass
	Note: Dwell time=Pulse Time (ms) × (1600 ÷ 4 ÷ 79) ×31.6 Second				
2DH5	Low channel	2.880	307.2	400	Pass
	Middle channel	2.880	307.2	400	Pass
	High channel	2.880	307.2	400	Pass
	Note: Dwell time=Pulse Time (ms) × (1600 ÷ 6 ÷ 79) ×31.6 Second				
8DPSK Mode					
3DH1	Low channel	0.380	121.6	400	Pass
	Middle channel	0.380	121.6	400	Pass
	High channel	0.380	121.6	400	Pass
	Note: Dwell time=Pulse Time (ms) × (1600 ÷ 2 ÷ 79) ×31.6 Second				
3DH3	Low channel	1.630	260.8	400	Pass
	Middle channel	1.630	260.8	400	Pass
	High channel	1.630	260.8	400	Pass
	Note: Dwell time=Pulse Time (ms) × (1600 ÷ 4 ÷ 79) ×31.6 Second				
3DH5	Low channel	2.896	308.9	400	Pass
	Middle channel	2.880	307.2	400	Pass
	High channel	2.896	308.9	400	Pass
	Note: Dwell time=Pulse Time (ms) × (1600 ÷ 6 ÷ 79) ×31.6 Second				

DH1: Low channel

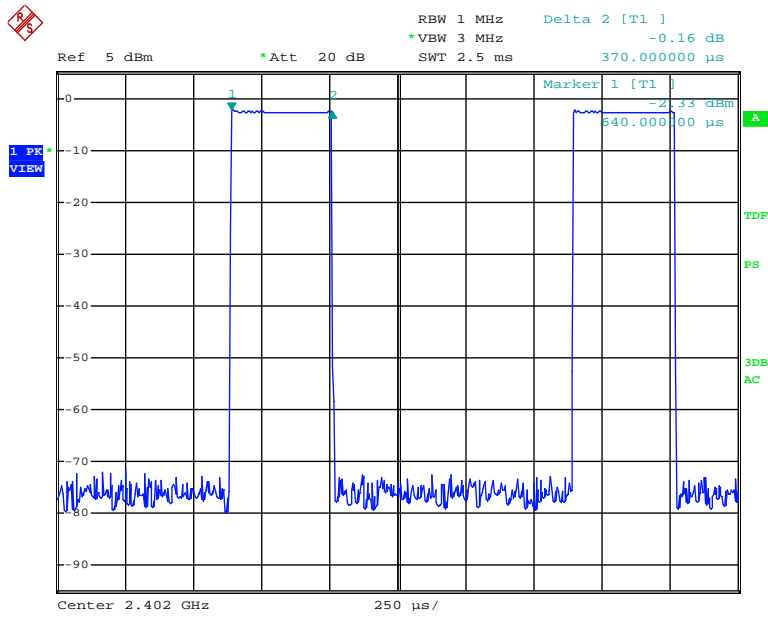

Date: 15.APR.2015 06:37:21

DH1: Middle channel

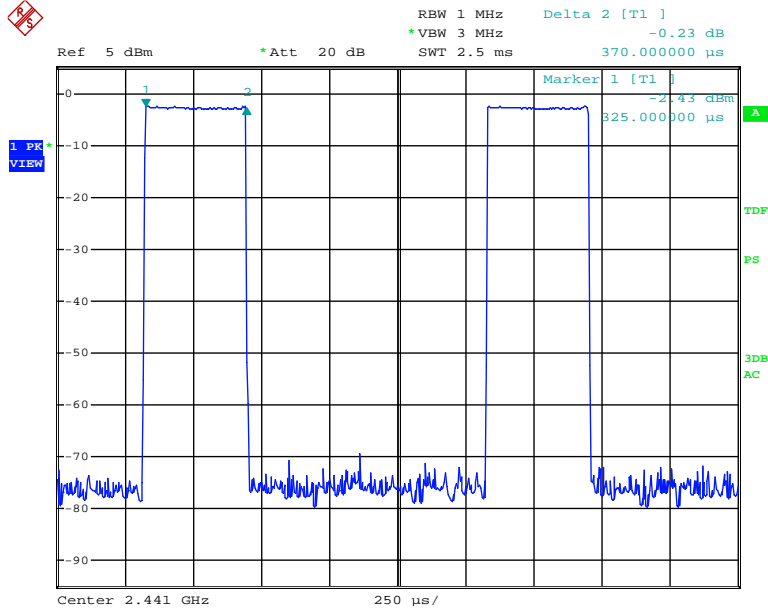

Date: 15.APR.2015 06:39:07

### DH1: High channel

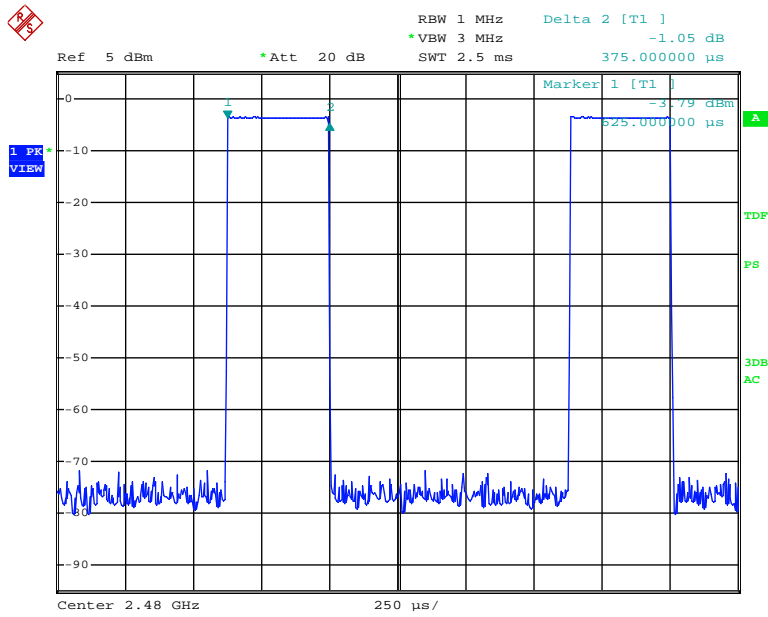

Date: 15.APR.2015 06:40:13

### DH3: Low channel

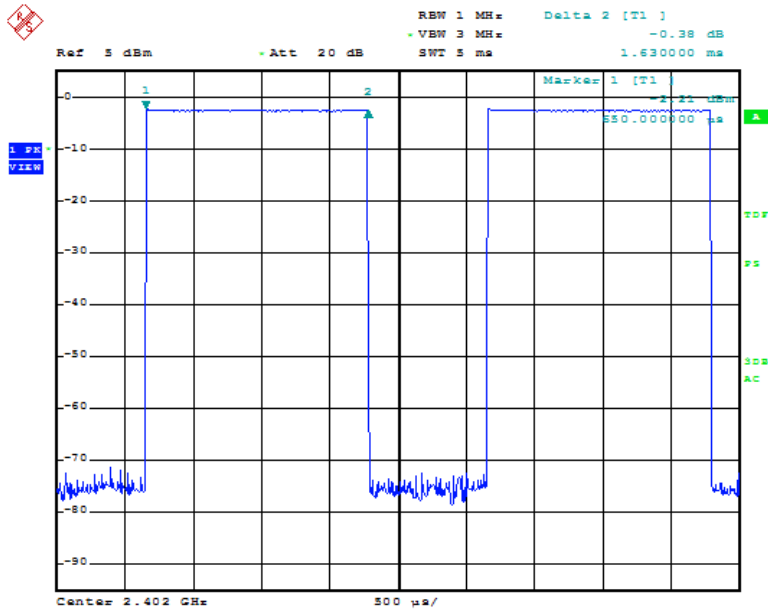

Date: 15.APR.2015 06:44:06

DH3: Middle channel

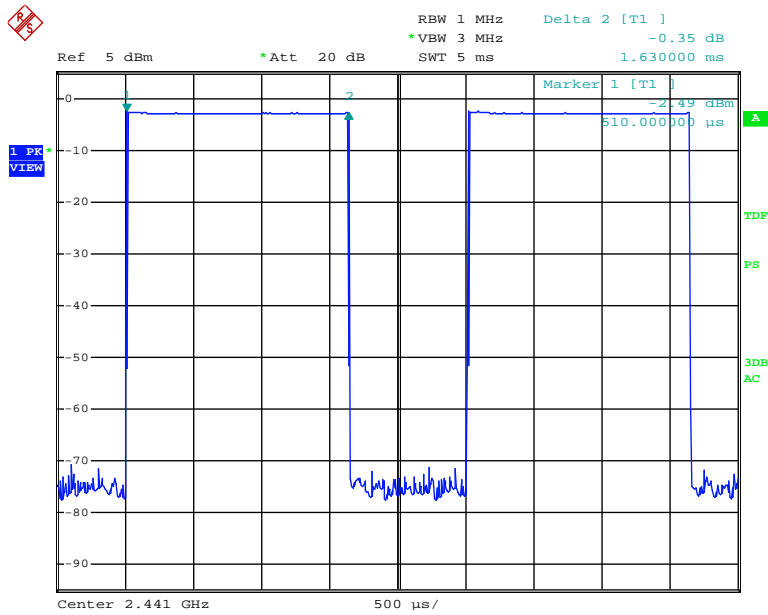

Date: 15.APR.2015 06:44:40

DH3: High channel

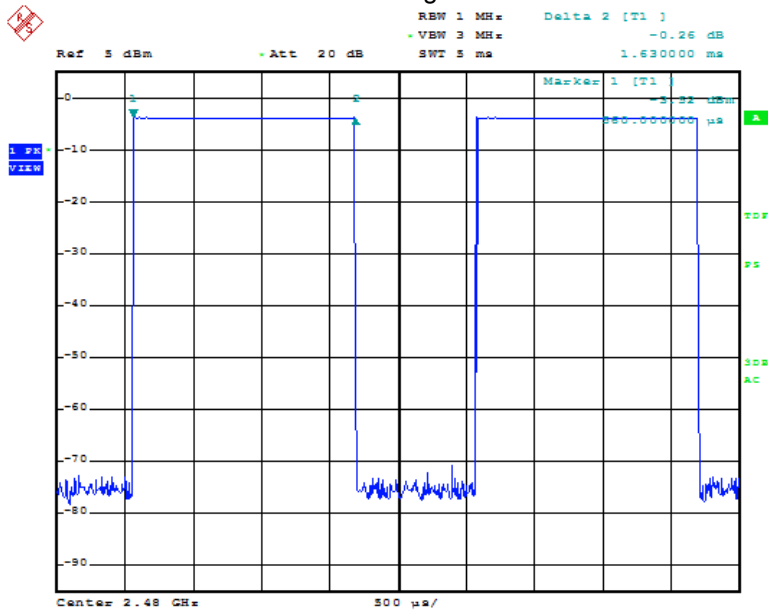

Date: 15.APR.2015 06:45:18



DH5: Low channel

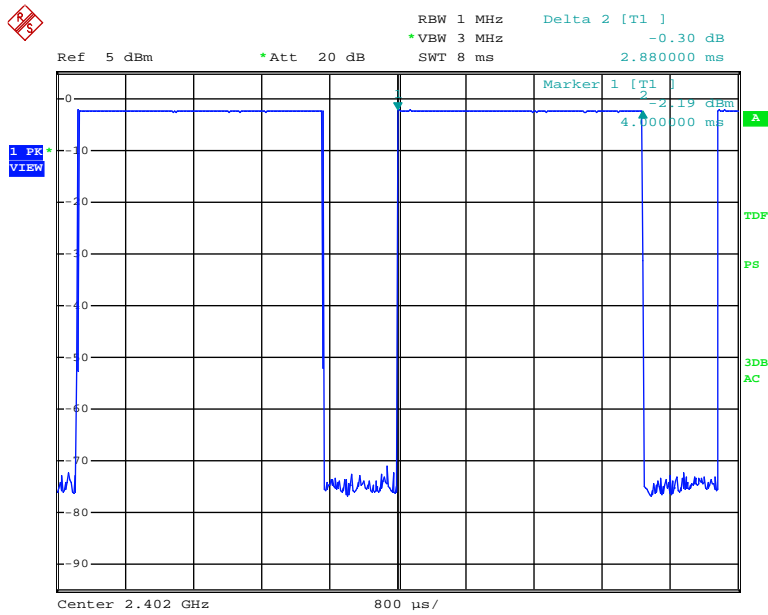

Date: 15.APR.2015 06:46:21

DH5: Middle channel

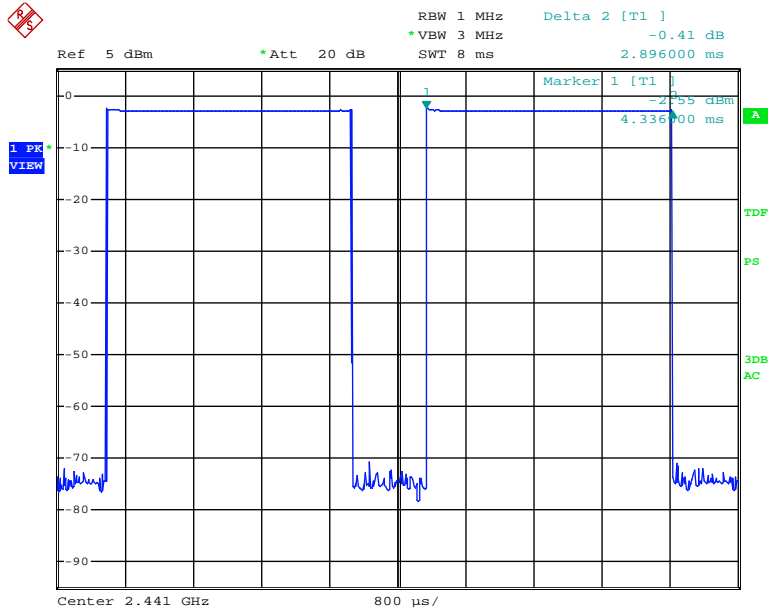

Date: 15.APR.2015 06:46:58

### DH5: High channel

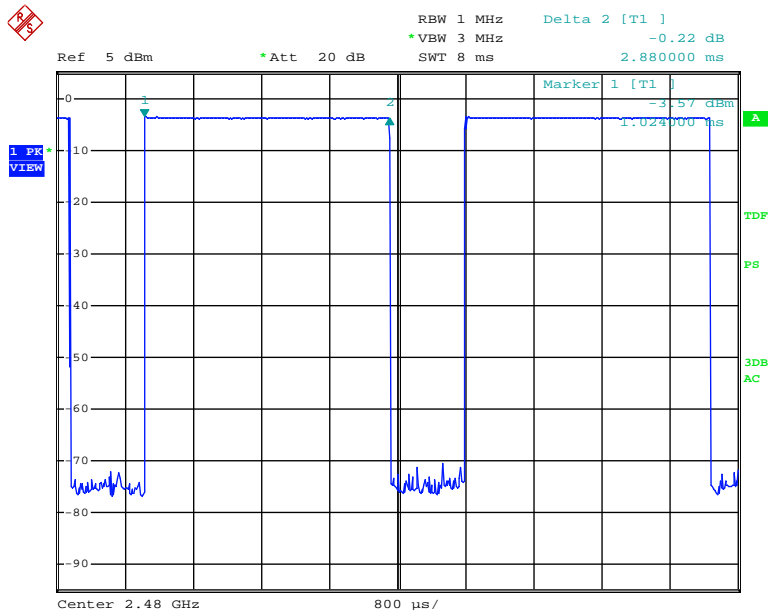

Date: 15.APR.2015 06:47:29

### 2DH1: Low channel

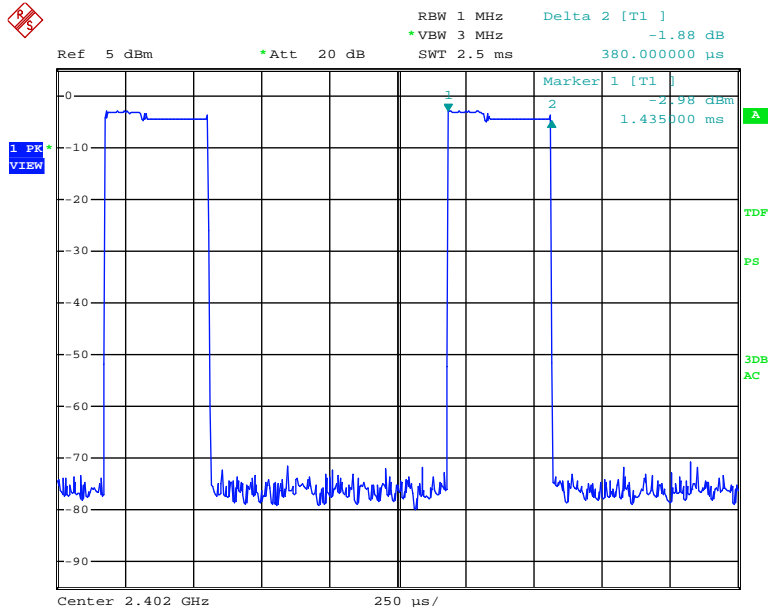

Date: 15.APR.2015 06:48:21

### 2DH1: Middle channel

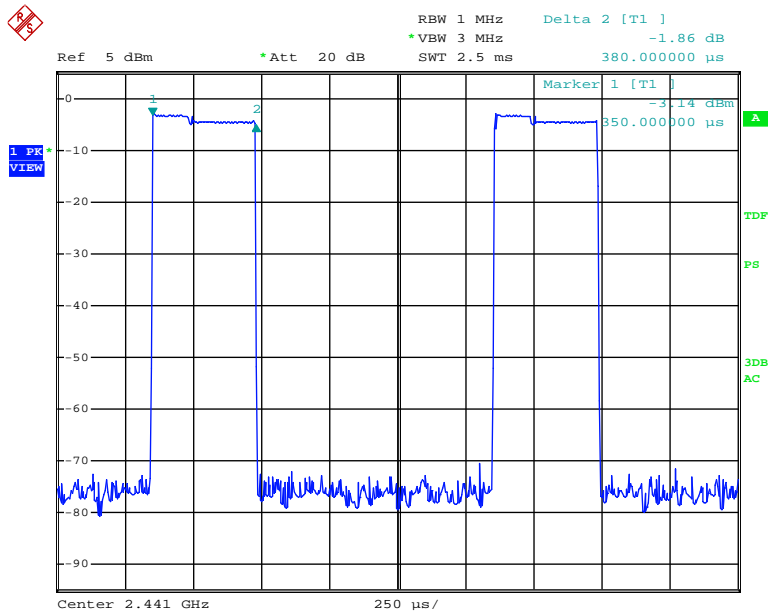

Date: 15.APR.2015 06:48:58

### 2DH1: High channel

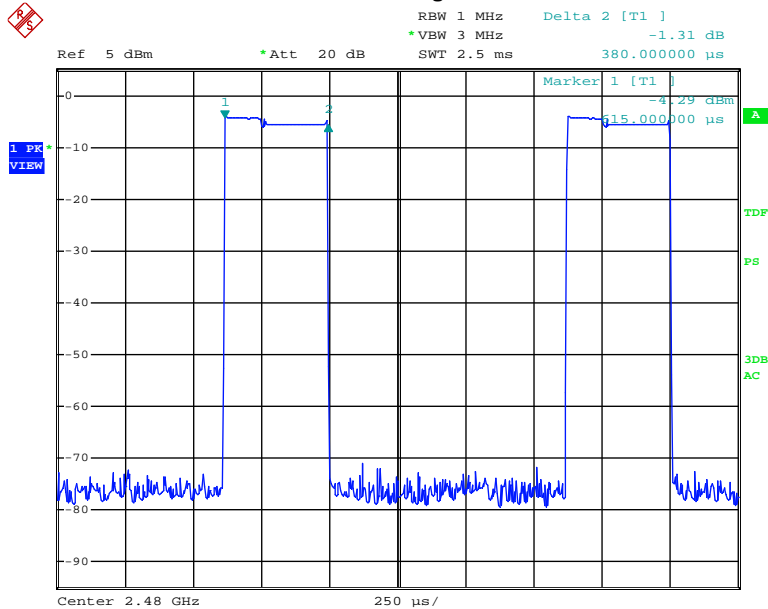

Date: 15.APR.2015 06:49:32

2DH3: Low channel

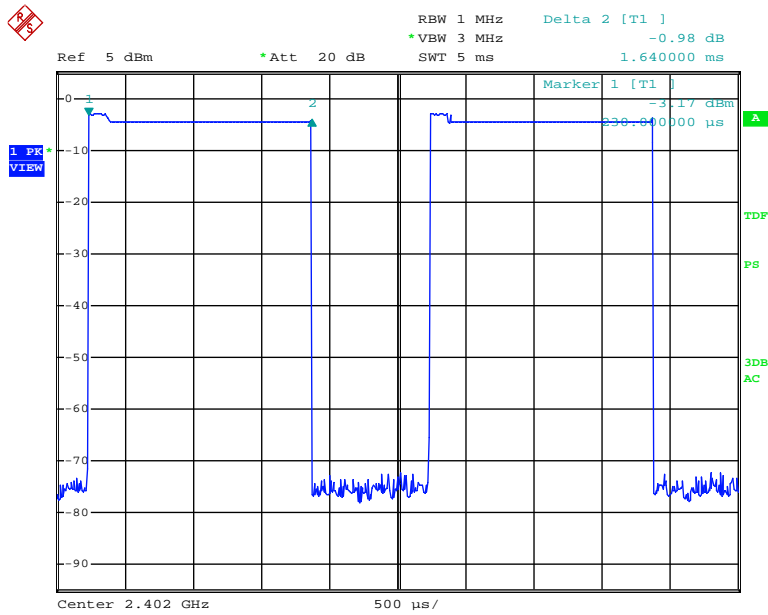

Date: 15.APR.2015 06:50:22

2DH3: Middle channel

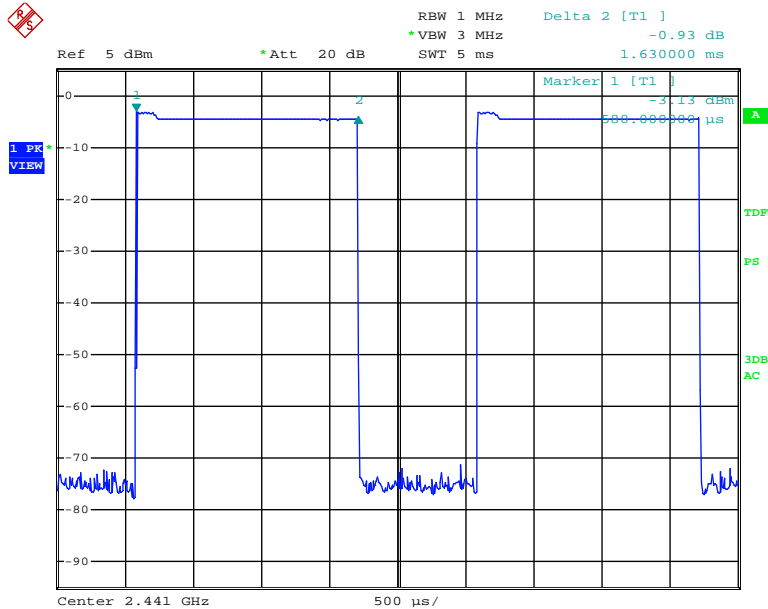

Date: 15.APR.2015 06:51:01

### 2DH3: High channel

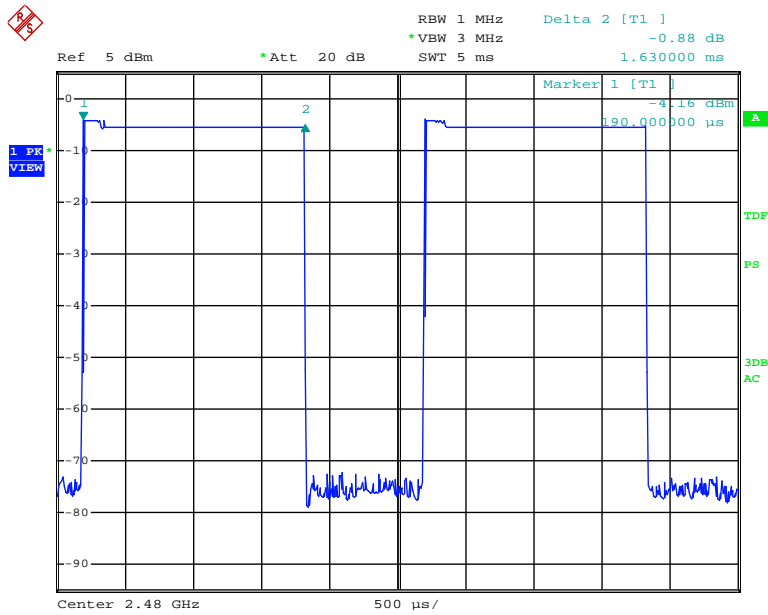

Date: 15.APR.2015 06:52:04

### 2DH5: Low channel

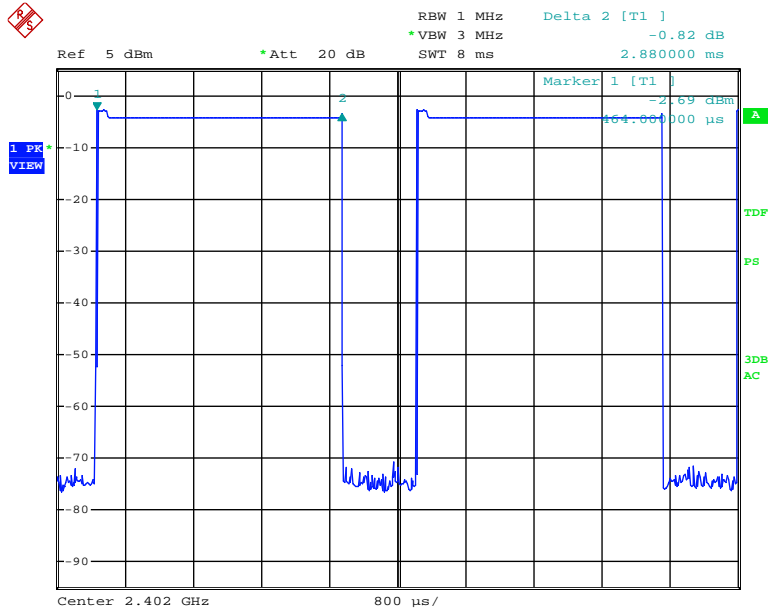

Date: 15.APR.2015 06:53:20

2DH5: Middle channel

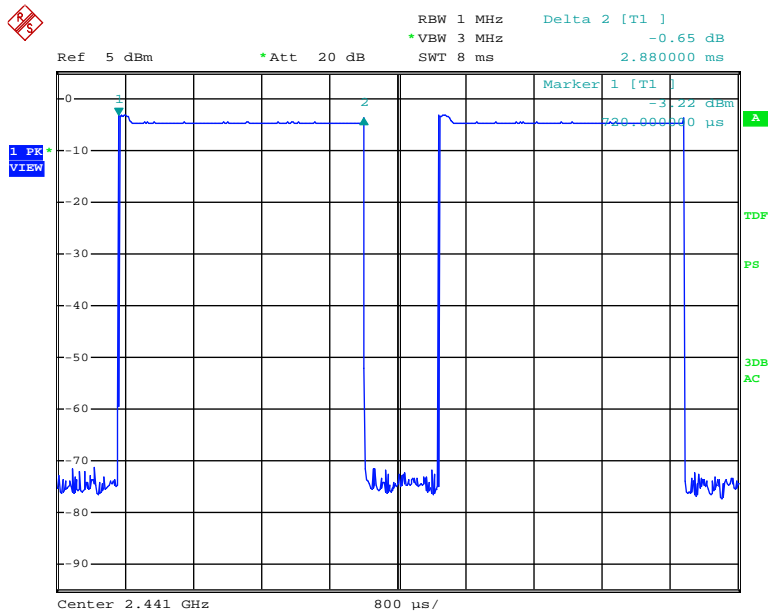

Date: 15.APR.2015 06:53:58

2DH5: High channel

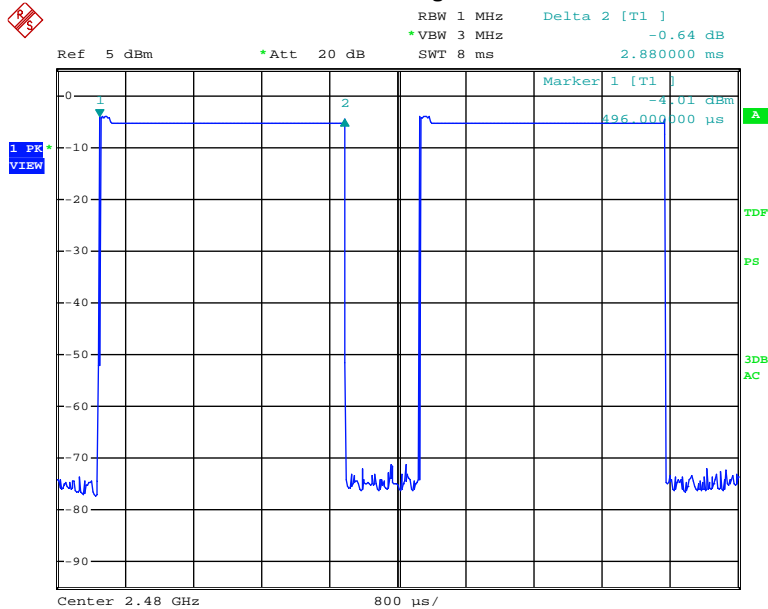

Date: 15.APR.2015 06:54:42

### 3DH1: Low channel

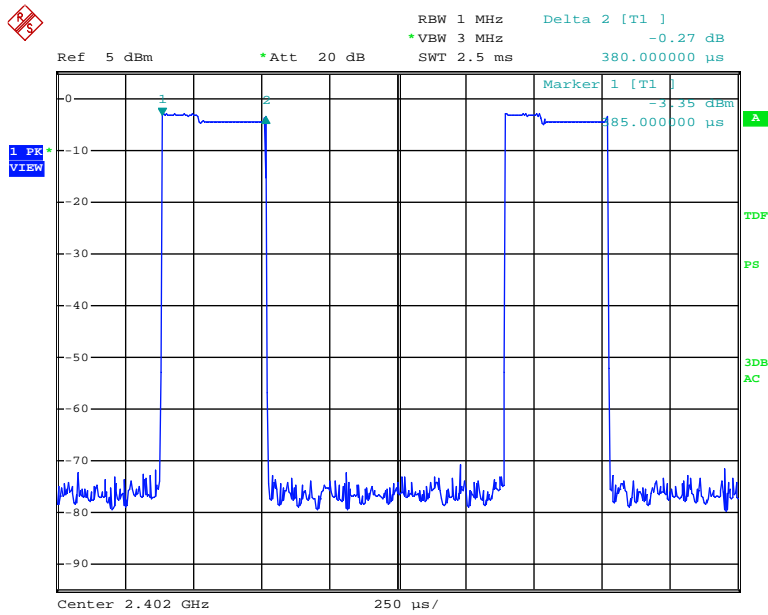

Date: 15.APR.2015 06:58:22

### 3DH1: Middle channel

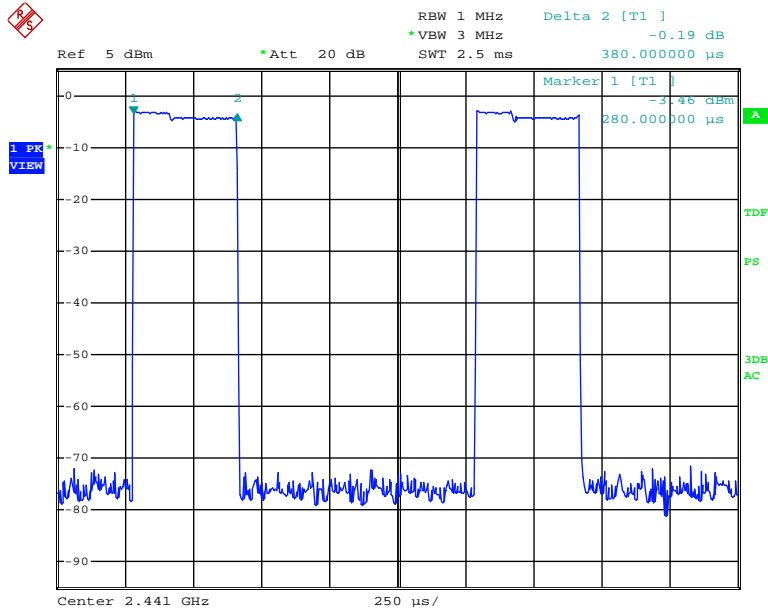

Date: 15.APR.2015 06:59:09

### 3DH1: High channel

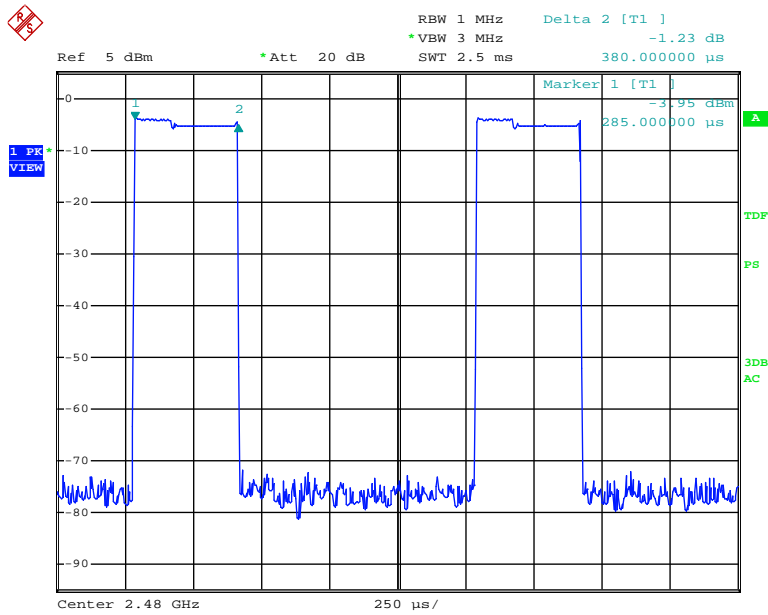

Date: 15.APR.2015 06:59:44

### 3DH3: Low channel

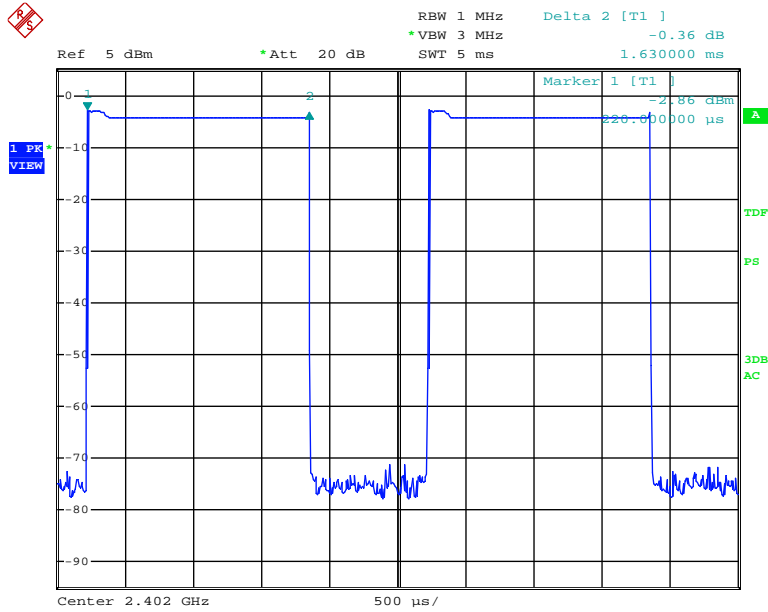

Date: 15.APR.2015 07:00:48



### 3DH3: Middle channel

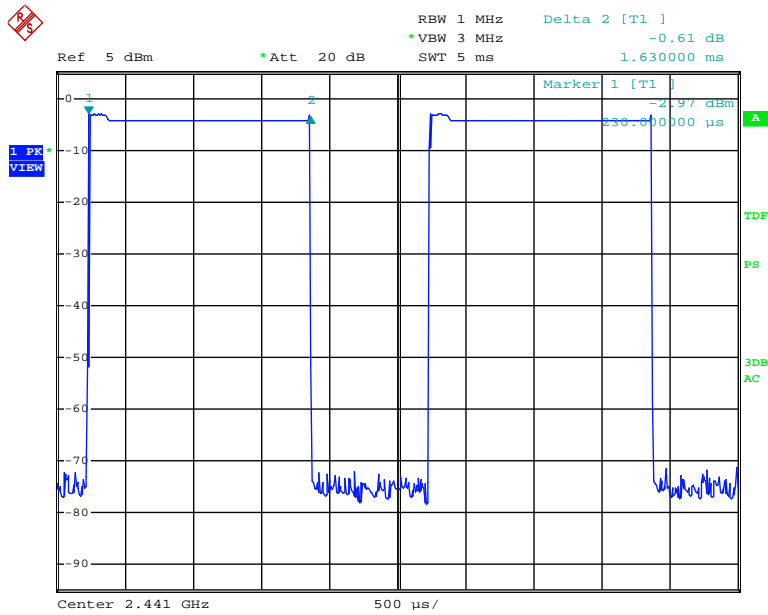

Date: 15.APR.2015 07:01:23

### 3DH3: High channel

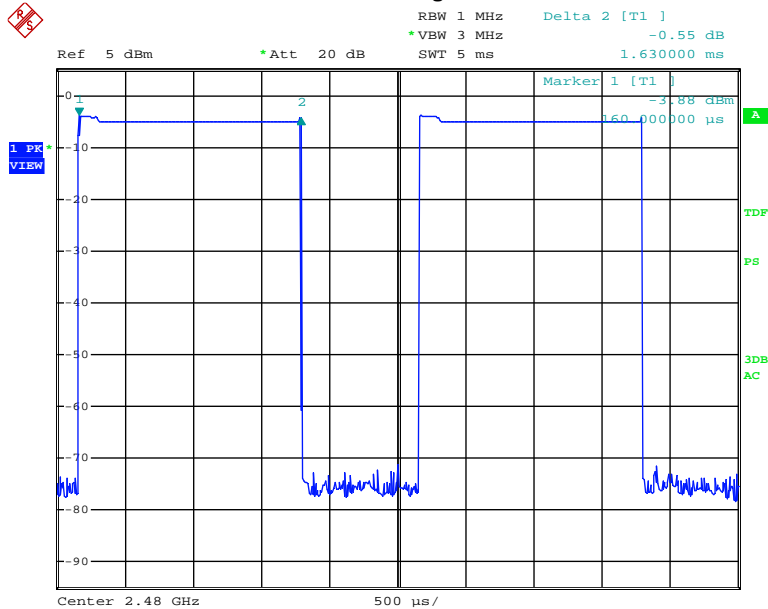

Date: 15.APR.2015 07:02:04

### 3DH5: Low channel

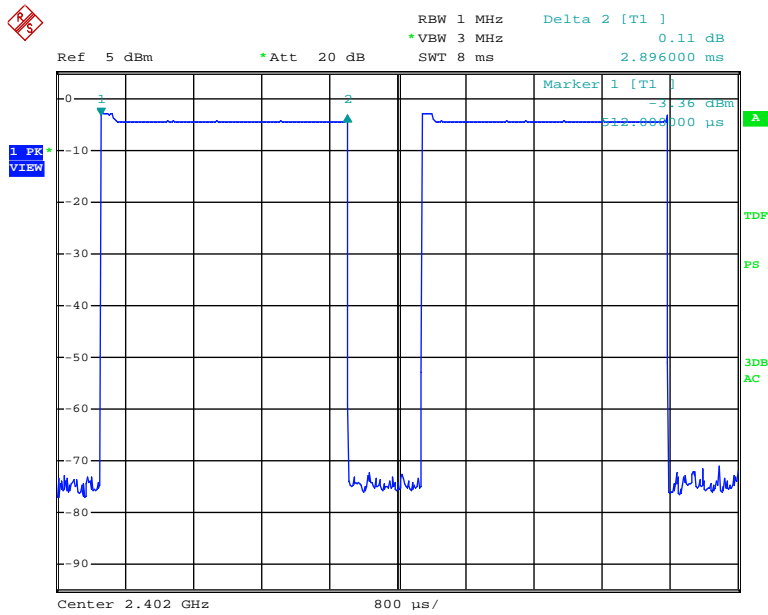

Date: 15.APR.2015 07:02:53

### 3DH5: Middle channel

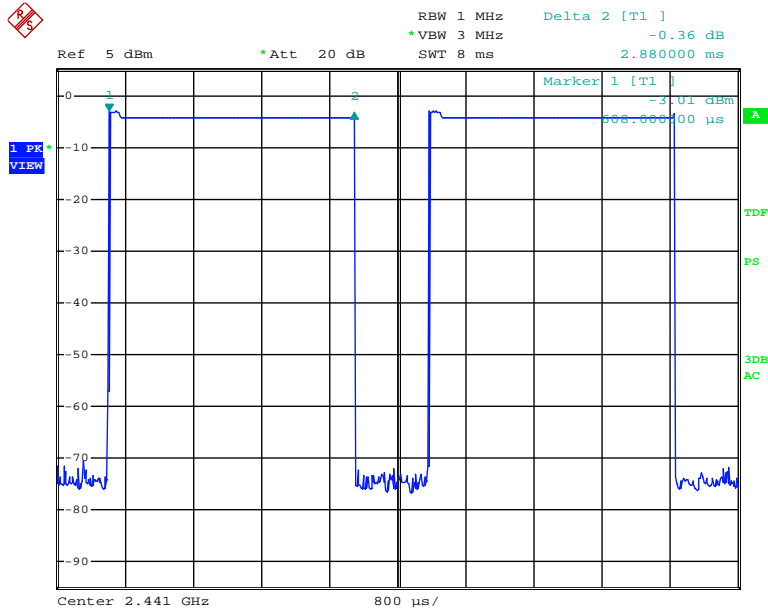

Date: 15.APR.2015 07:03:41

**3DH5: High channel**

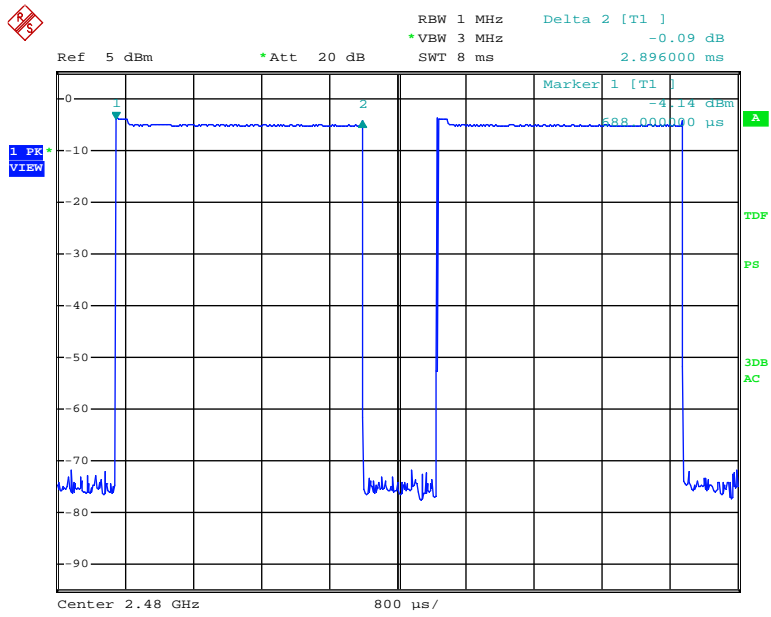

Date: 15.APR.2015 07:04:15

## 10. Maximum Peak Output Power Test

### 10.1 Measurement Procedure

- a. Check the calibration of the measuring instrument(SA) using either an internal calibrator or a known signal from an external generator.
- b. Turn on the EUT and connect it to measurement instrument. Then set it to any one convenient frequency within its operating range. Set a reference level on the measuring instrument equal to the highest peak value.
- c. The center frequency of the spectrum analyzer is set to the fundamental frequency and using proper RBW and VBW setting.
- d. Measure the captured power within the band and recording the plot.
- e. Repeat above procedures until all frequencies required were complete.

### 10.2 Test SET-UP (Block Diagram of Configuration)

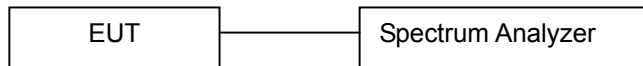

### 10.3 Measurement Equipment Used

Name of Equipment	Manufacturer	Model	Serial Number	Last Cal.	CAL DUE.
Spectrum Analyzer	Rohde & Schwarz	ESCI	10017	08/01/2014	08/01/2015

### 10.4 Measurement Results

Refer to attached data chart.

Spectrum Detector: PK                      Test Date : 03/24/2015  
 Test By: Kuki                                Temperature : 21 °C  
 Test Result: PASS                          Humidity : 55 %

GFSK Mode					
Channel	Channel Frequency (MHz)	Peak Power output(dBm)	Peak Power output(mW)	Peak Power Limit(W)	Pass/Fail
Low channel	2402.00	-0.54	0.883	1	PASS
Middle channel	2441.00	-1.28	0.744	1	PASS
High channel	2480.00	-2.16	0.608	1	PASS
π/4-DQPSK Mode					
Channel	Channel Frequency (MHz)	Peak Power output(dBm)	Peak Power output(mW)	Peak Power Limit(mW)	Pass/Fail
Low channel	2402.00	-1.46	0.714	125	PASS
Middle channel	2441.00	-1.89	0.647	125	PASS
High channel	2480.00	-2.74	0.532	125	PASS
8DPSK Mode					
Channel	Channel Frequency (MHz)	Peak Power output(dBm)	Peak Power output(mW)	Peak Power Limit(mW)	Pass/Fail
Low channel	2402.00	-1.55	0.699	125	PASS
Middle channel	2441.00	-1.92	0.642	125	PASS
High channel	2480.00	-2.74	0.532	125	PASS

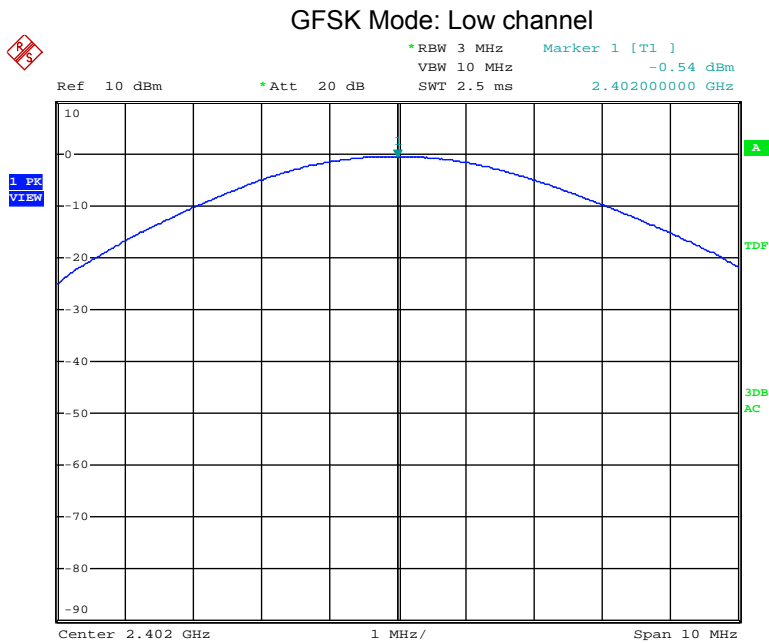

Date: 19.MAY.2015 17:45:30

GFSK Mode: Middle channel

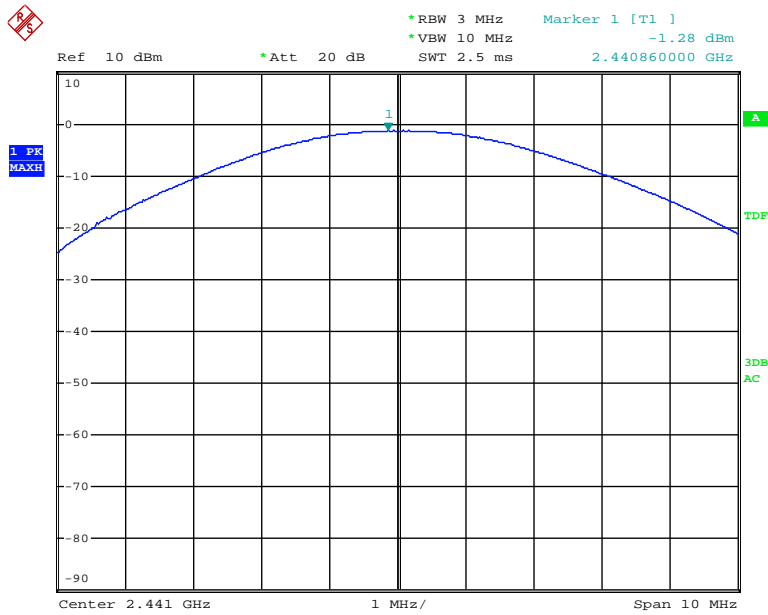

Date: 24.MAR.2015 05:25:35

GFSK Mode: High channel

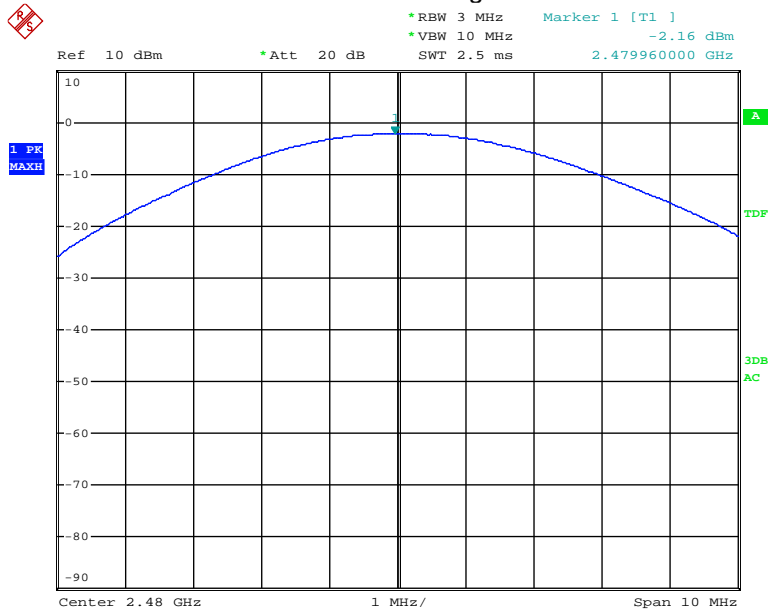

Date: 24.MAR.2015 05:26:00

$\pi/4$ -DQPSK Mode: Low channel

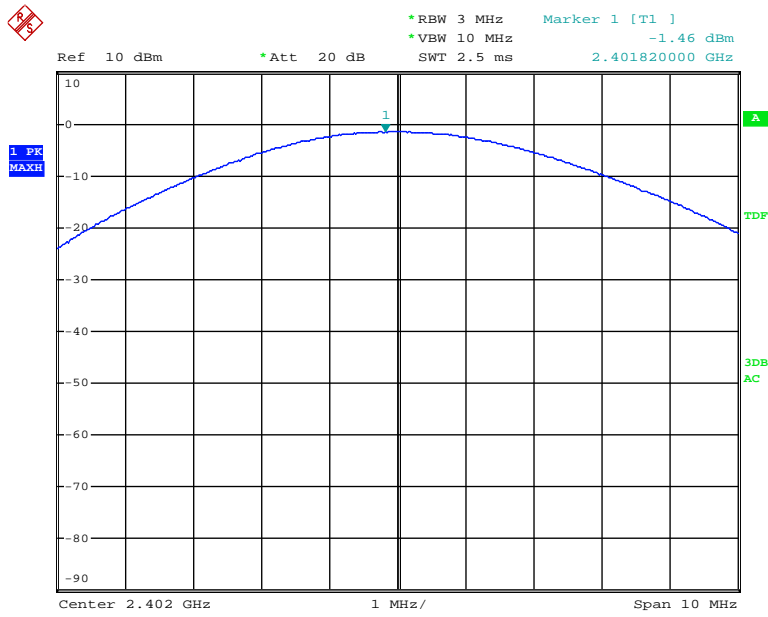

Date: 24.MAR.2015 05:26:52

$\pi/4$ -DQPSK Mode: Middle channel

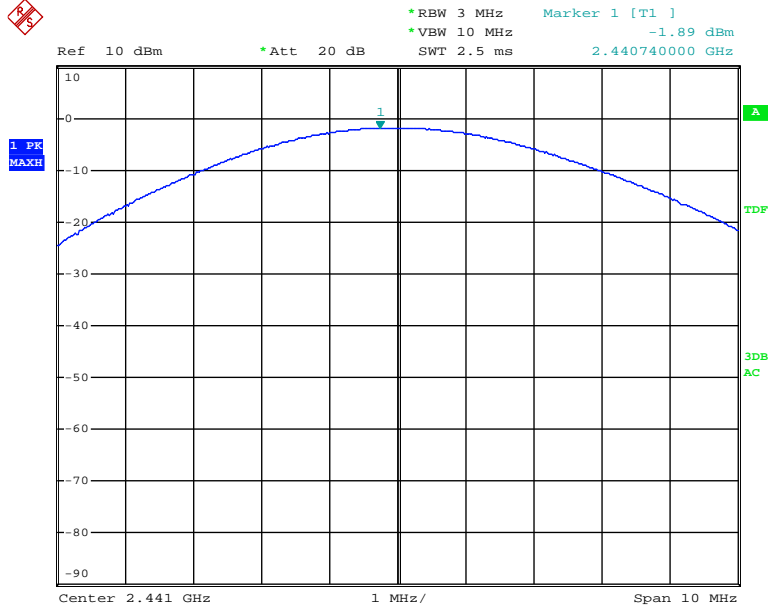

Date: 24.MAR.2015 05:27:29

$\pi/4$ -DQPSK Mode: High channel

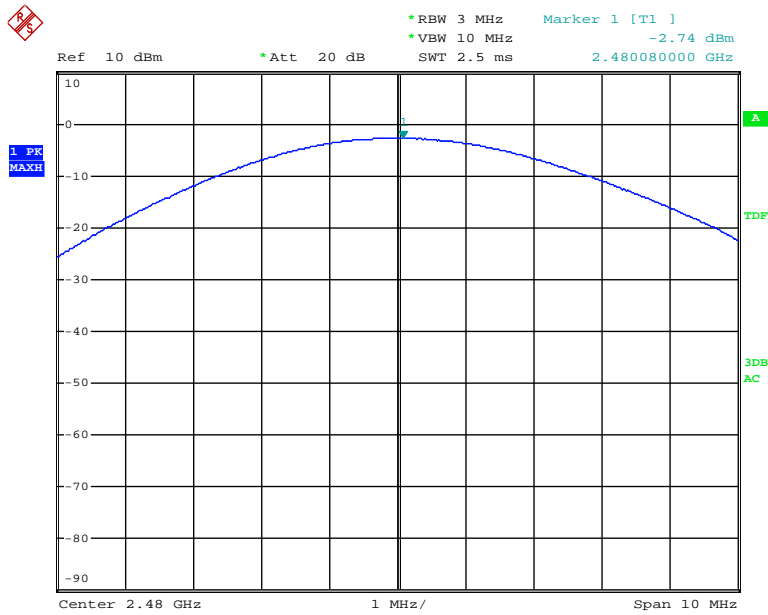

Date: 24.MAR.2015 05:28:03

8DPSK Mode: Low channel

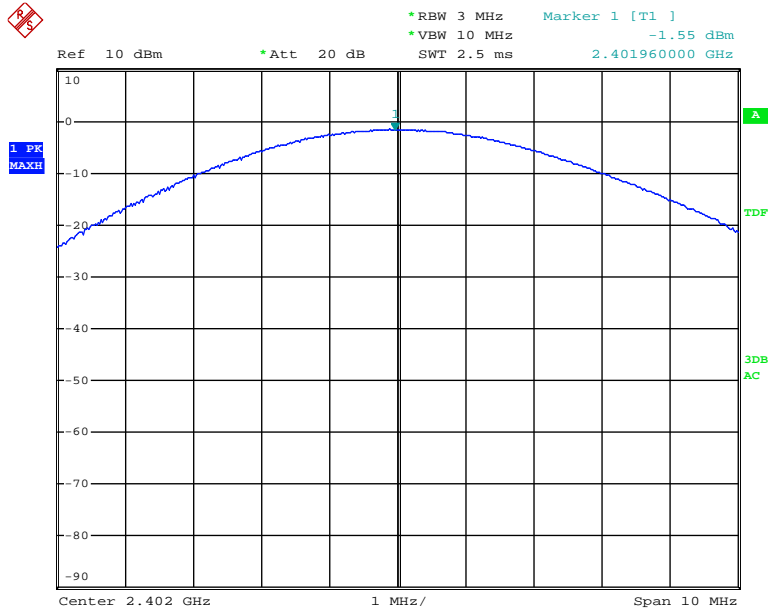

Date: 24.MAR.2015 05:28:48



8DPSK Mode: Middle channel

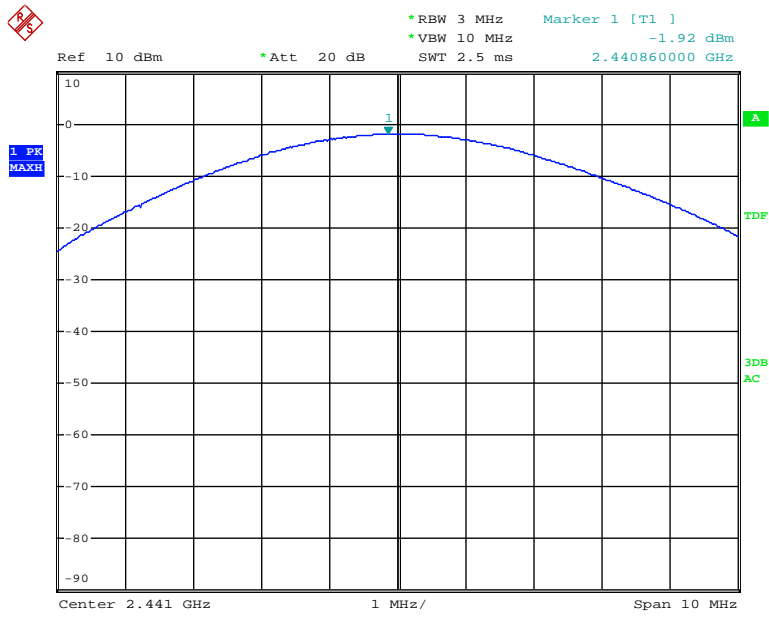

Date: 24.MAR.2015 05:29:23

8DPSK Mode: High channel

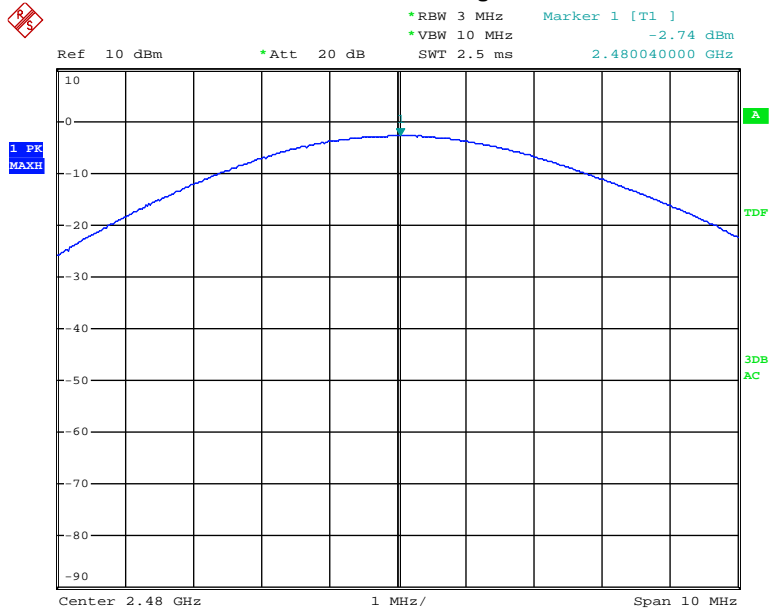

Date: 24.MAR.2015 05:29:58

## 11. Band Edge Test

### 11.1 Applicable Standard

In any 100 kHz bandwidth outside the frequency band in which the spread spectrum or digitally modulated intentional radiator is operating, the radio frequency power that is produced by the intentional radiator shall be at least 20 dB below that in the 100 kHz bandwidth within the band that contains the highest level of the desired power, based on either an RF conducted or a radiated measurement, provided the transmitter demonstrates compliance with the peak conducted power limits. If the transmitter complies with the conducted power limits based on the use of RMS averaging over a time interval, as permitted under paragraph (b)(3) of this section, the attenuation required under this paragraph shall be 30 dB instead of 20 dB. Attenuation below the general limits specified in §15.209(a) is not required. In addition, radiated emissions which fall in the restricted bands, as defined in §15.205(a), must also comply with the radiated emission limits specified in §15.209(a) (see §15.205(c)).

### 11.2 Measurement Procedure

(A) Conducted method:

Measurements were performed using a spectrum analyzer with a suitable span to encompass the peak of the fundamental and using the following settings: RBW = 100kHz, VBW = 300kHz.

(B) Radiated method:

1. The EUT was Operating in hopping mode or could be controlled its channel. Printed out test result from the spectrum by hard copy function.
2. The EUT was placed on a turn table which is 0.8m above ground plane.
3. Maximum procedure was performed on the six highest emissions to ensure EUT compliance.
4. And also, each emission was to be maximized by changing the polarization of receiving antenna both horizontal and vertical.
5. Repeat above procedures until all frequency measured were complete.  
(Peak measurement: Peak detector, RBW=1MHz, VBW=3MHz, Sweep=Auto  
Average measurement: Peak detector, RBW=1MHz, VBW=10Hz, Sweep=Auto)

### 11.3 Measurement Equipment Used

Conducted method: Same as 6.3 Channel Separation Measurement.

Radiated method: Same as 5.3 Radiated Emission Measurement.

### 11.4 Measurement Results

Pass

Refer to attached data chart.

(A) Conducted Measurement

For Hopping Mode:

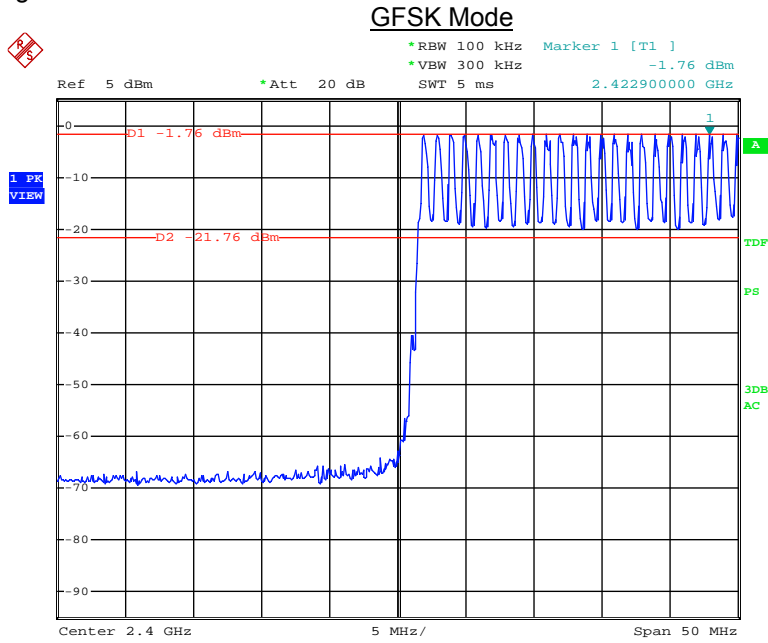

Date: 15.APR.2015 07:34:02

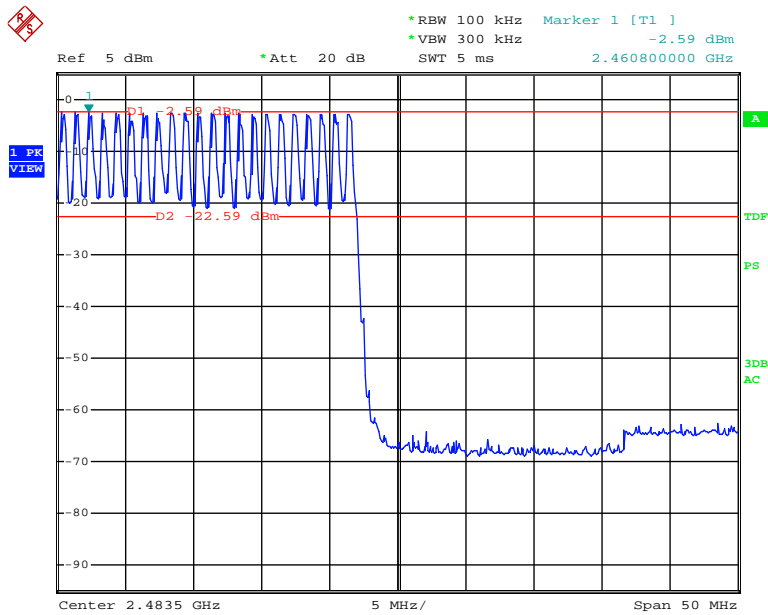

Date: 15.APR.2015 07:42:06

**$\pi/4$ -DQPSK Mode**

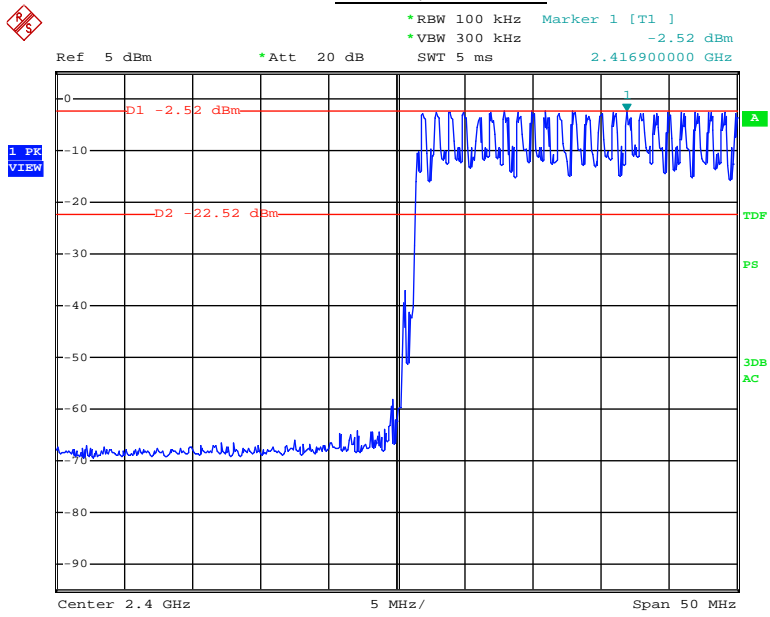

Date: 15.APR.2015 07:45:42

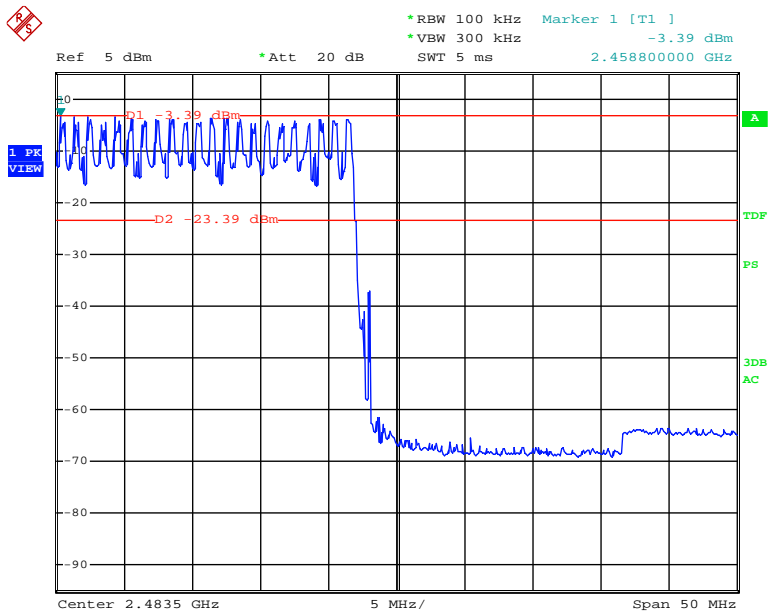

Date: 15.APR.2015 07:52:26

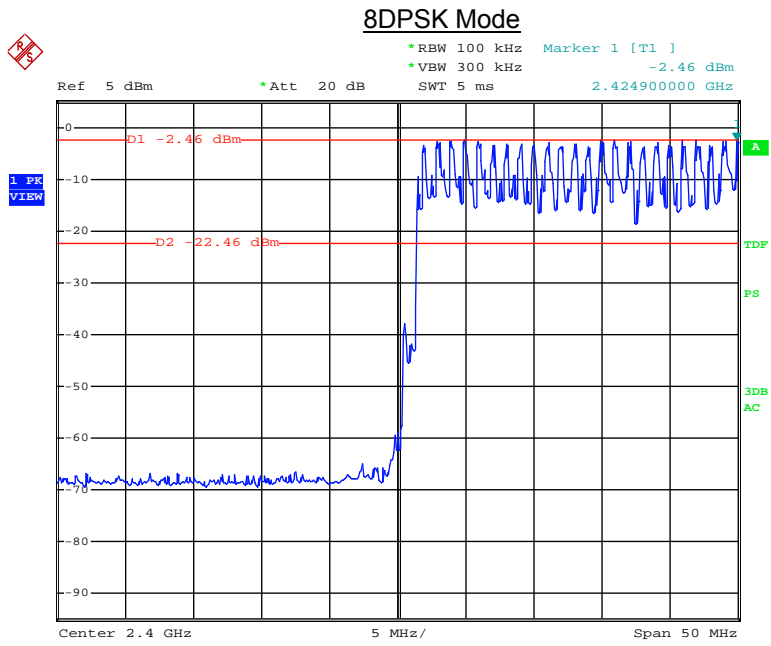

Date: 15.APR.2015 07:55:22

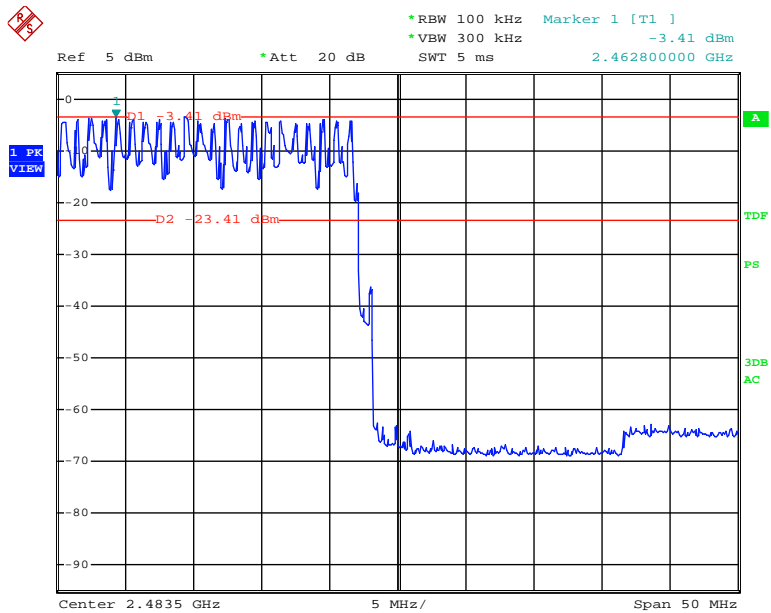

Date: 15.APR.2015 07:58:49

For Non-Hopping Mode

GFSK Mode

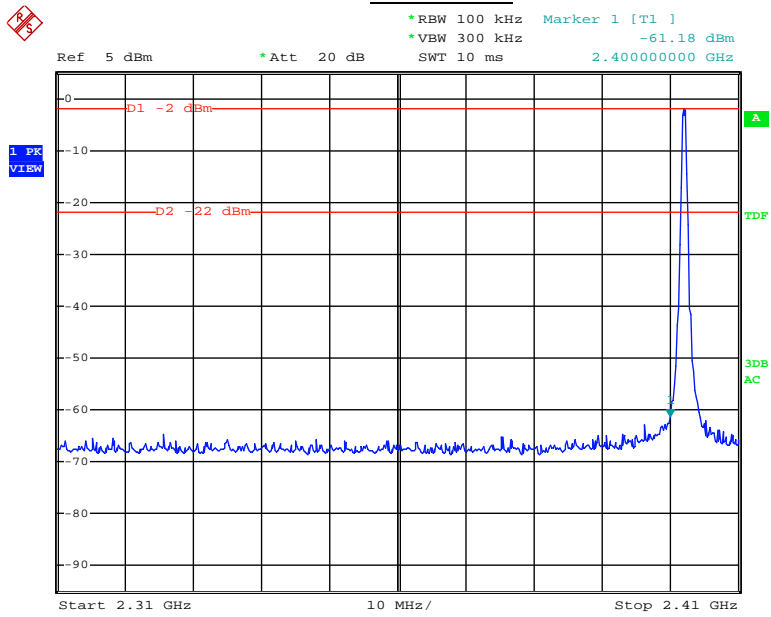

Date: 21.MAY.2015 08:58:36

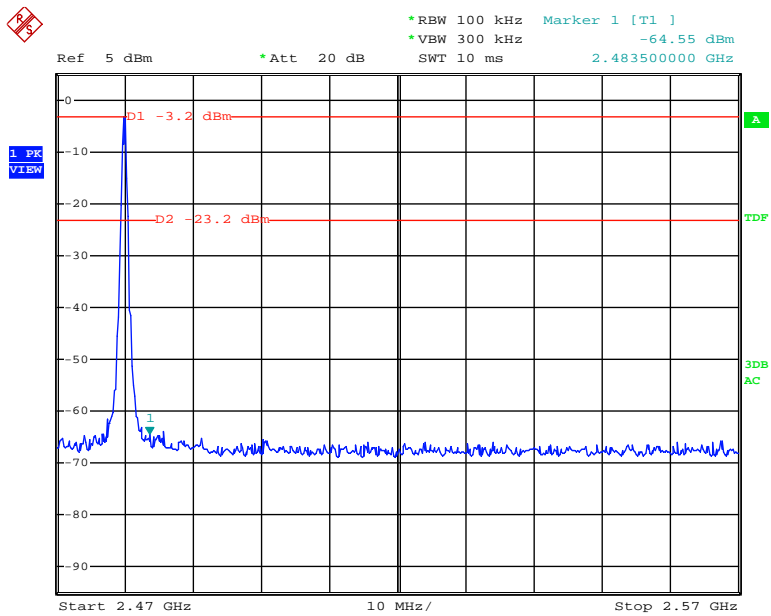

Date: 21.MAY.2015 08:59:59

$\pi/4$ -DQPSK Mode

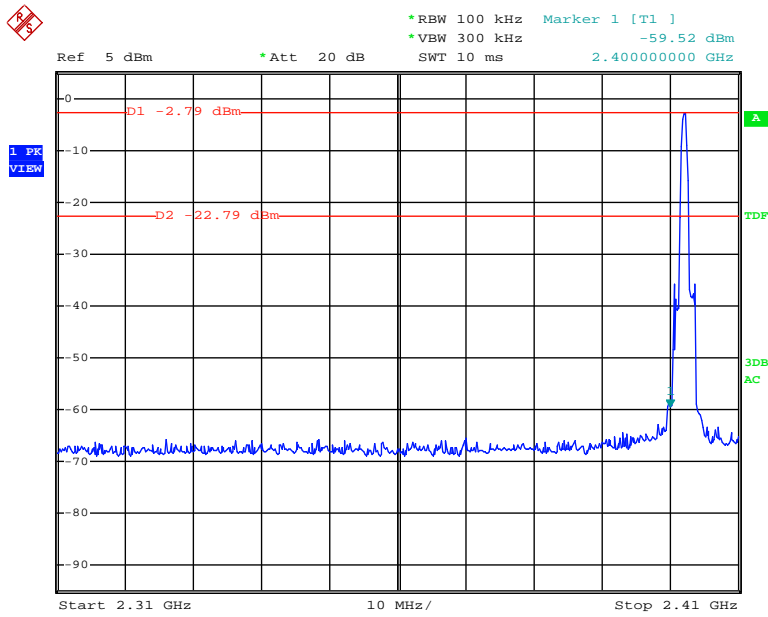

Date: 21.MAY.2015 09:07:08

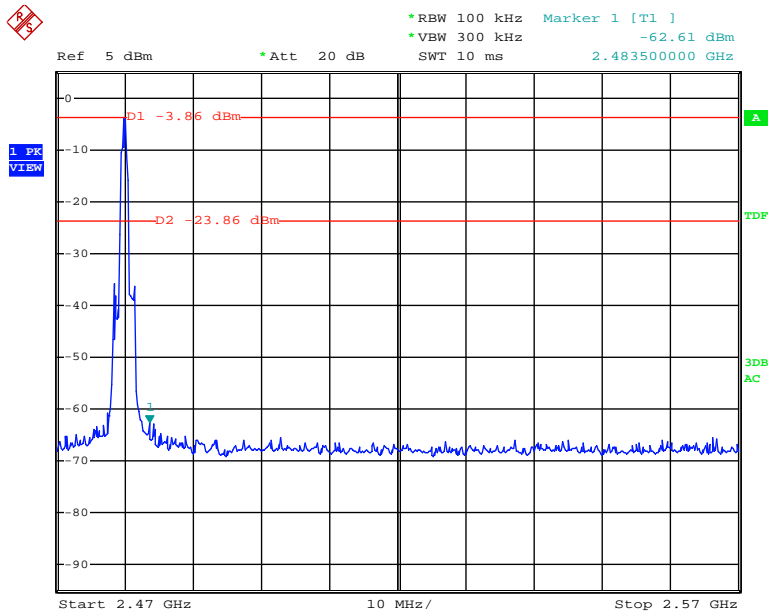

Date: 21.MAY.2015 09:08:52

**8DPSK Mode**

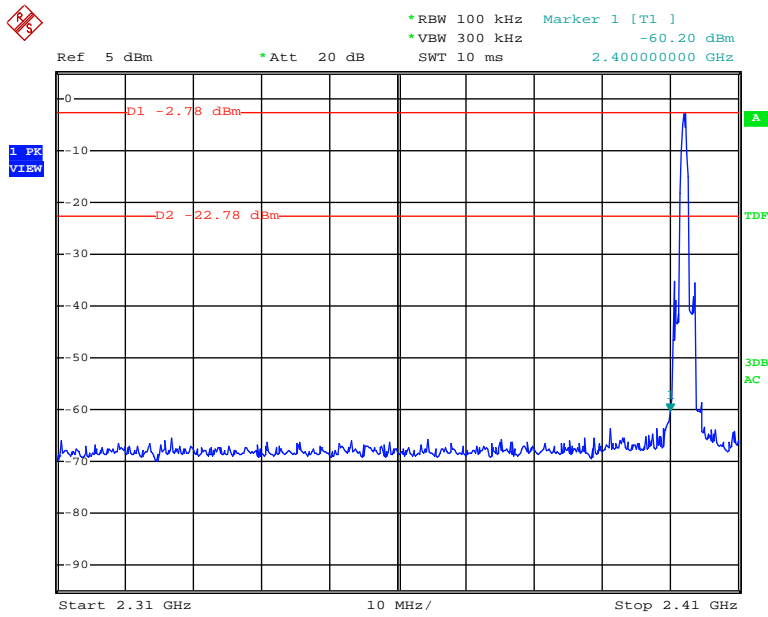

Date: 21.MAY.2015 09:10:00

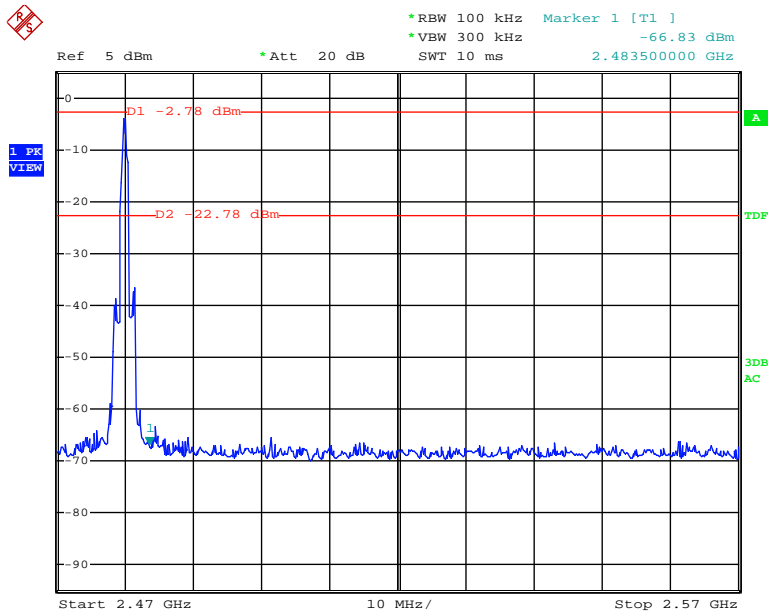

Date: 21.MAY.2015 09:11:23



(B) Radiated Measurement

For Hopping Mode:

8DPSK Mode

Vertical:

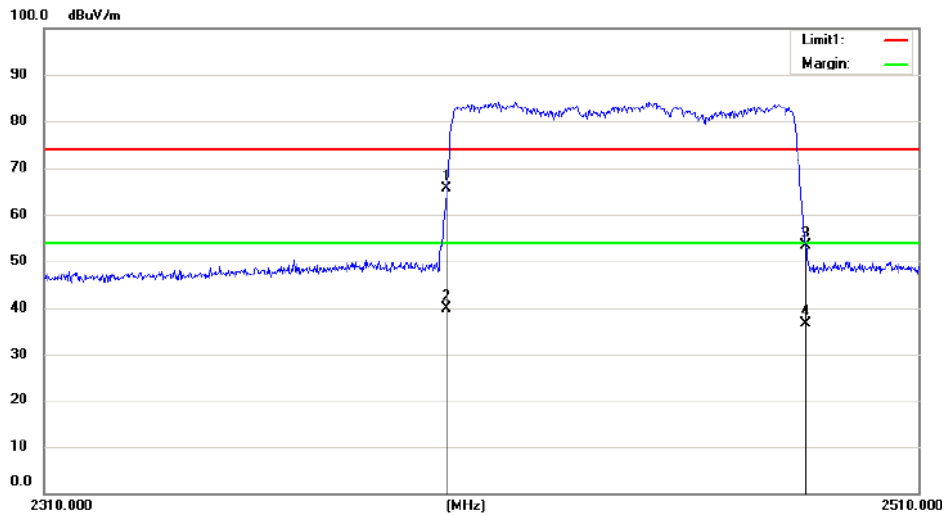

No.	Mk.	Freq.	Reading Level	Correct Factor	Measurement	Limit	Over	Detector
		MHz	dBuV	dB	dBuV/m	dBuV/m	dB	
1	*	2400.000	54.70	10.93	65.63	73.90	-8.27	peak
2		2400.000	28.87	10.93	39.80	53.90	-14.10	AVG
3		2483.500	42.41	11.00	53.41	73.90	-20.49	peak
4		2483.500	25.60	11.00	36.60	53.90	-17.30	AVG

Horizontal:

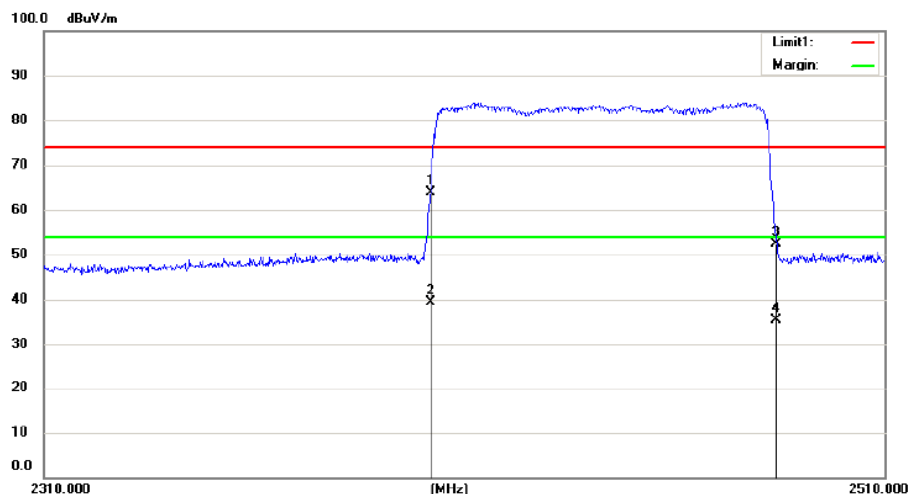

No.	Mk.	Freq.	Reading Level	Correct Factor	Measurement	Limit	Over	Detector
		MHz	dBuV	dB	dBuV/m	dBuV/m	dB	
1	*	2400.000	52.97	10.93	63.90	73.90	-10.00	peak
2		2400.000	28.57	10.93	39.50	53.90	-14.40	AVG
3		2483.500	41.41	11.00	52.41	73.90	-21.49	peak
4		2483.500	24.30	11.00	35.30	53.90	-18.60	AVG

$\pi/4$ -DQPSK Mode

Vertical:

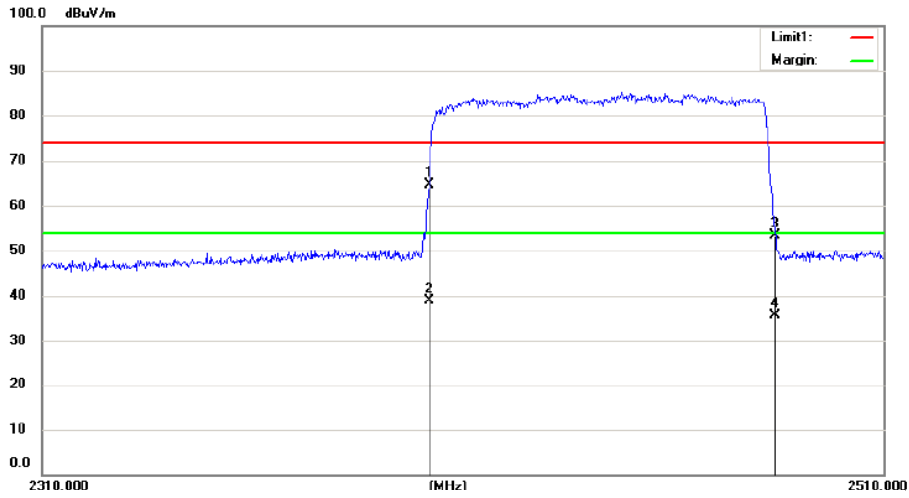

No.	Mk.	Freq.	Reading Level	Correct Factor	Measurement	Limit	Over	
		MHz	dBuV	dB	dBuV/m	dBuV/m	dB	Detector
1	*	2400.000	52.97	10.93	63.90	73.90	-10.00	peak
2		2400.000	28.57	10.93	39.50	53.90	-14.40	AVG
3		2483.500	41.41	11.00	52.41	73.90	-21.49	peak
4		2483.500	24.30	11.00	35.30	53.90	-18.60	AVG

Horizontal:

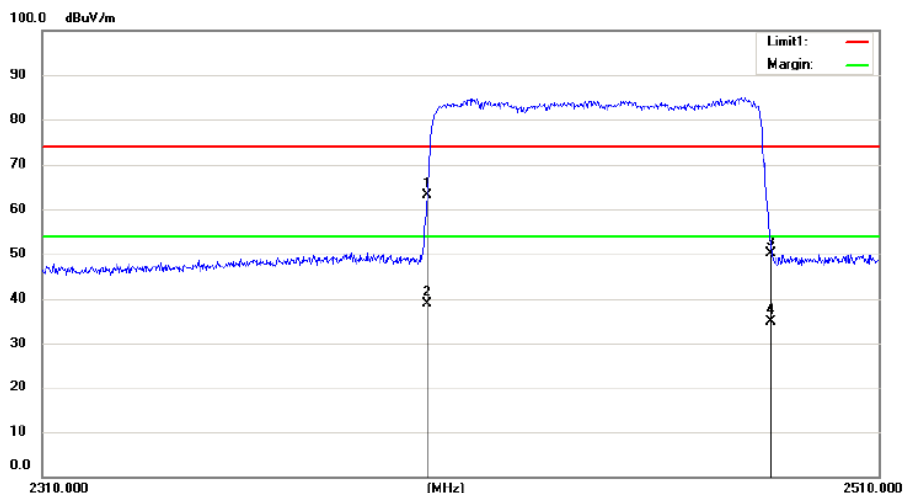

No.	Mk.	Freq.	Reading Level	Correct Factor	Measurement	Limit	Over	
		MHz	dBuV	dB	dBuV/m	dBuV/m	dB	Detector
1	*	2400.000	52.28	10.93	63.21	73.90	-10.69	peak
2		2400.000	27.87	10.93	38.80	53.90	-15.10	AVG
3		2483.500	39.18	11.00	50.18	73.90	-23.72	peak
4		2483.500	24.00	11.00	35.00	53.90	-18.90	AVG

GFSK Mode

Vertical:

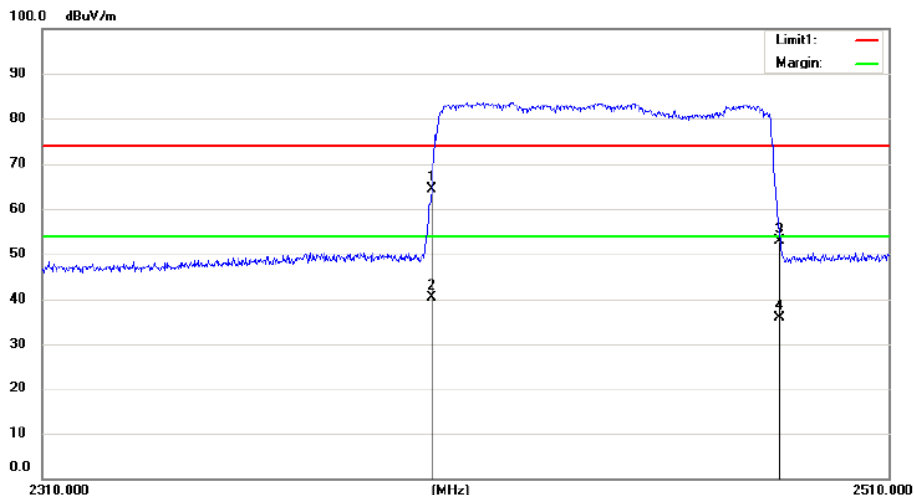

No.	Mk.	Freq.	Reading Level	Correct Factor	Measurement	Limit	Over	Detector
		MHz	dBuV	dB	dBuV/m	dBuV/m	dB	
1	*	2400.000	52.28	10.93	63.21	73.90	-10.69	peak
2		2400.000	27.87	10.93	38.80	53.90	-15.10	AVG
3		2483.500	39.18	11.00	50.18	73.90	-23.72	peak
4		2483.500	24.00	11.00	35.00	53.90	-18.90	AVG

Horizontal:

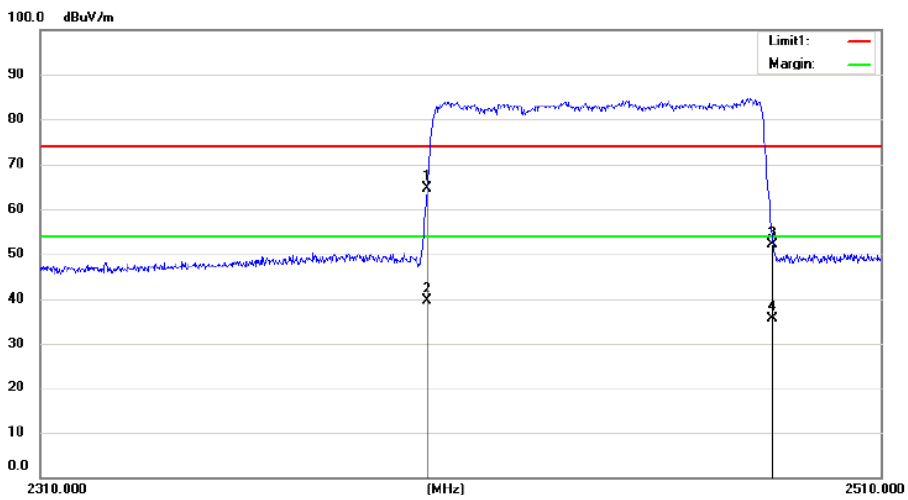

No.	Mk.	Freq.	Reading Level	Correct Factor	Measurement	Limit	Over	Detector
		MHz	dBuV	dB	dBuV/m	dBuV/m	dB	
1	*	2400.000	53.47	10.93	64.40	73.90	-9.50	peak
2		2400.000	29.57	10.93	40.50	53.90	-13.40	AVG
3		2483.500	41.84	11.00	52.84	73.90	-21.06	peak
4		2483.500	24.80	11.00	35.80	53.90	-18.10	AVG

For Non-Hopping Mode:

GFSK Mode

Low Channel (Vertical):

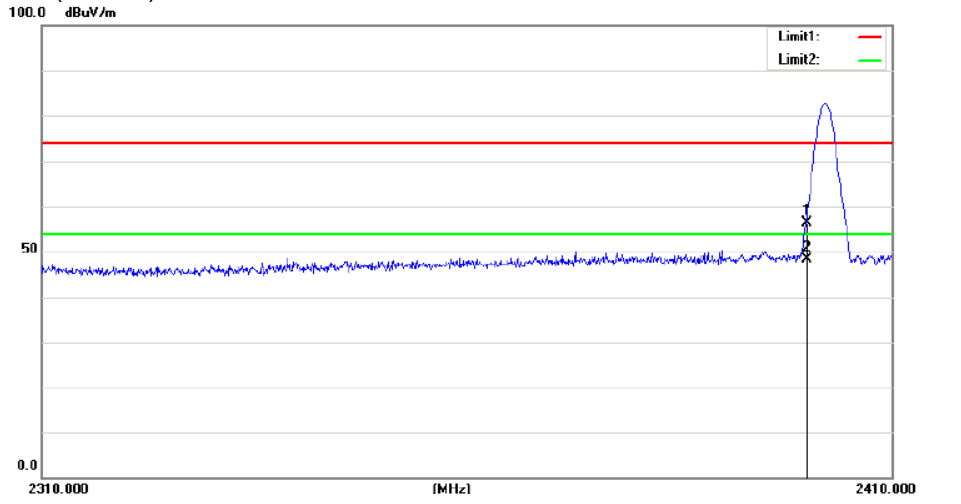

No.	Mk.	Freq.	Reading Level	Correct Factor	Measurement	Limit	Over	Detector
		MHz	dBuV	dB	dBuV/m	dBuV/m	dB	
1		2400.000	45.55	10.93	56.48	73.90	-17.42	peak
2	*	2400.000	37.57	10.93	48.50	53.90	-5.40	AVG

Low Channel (Horizontal):

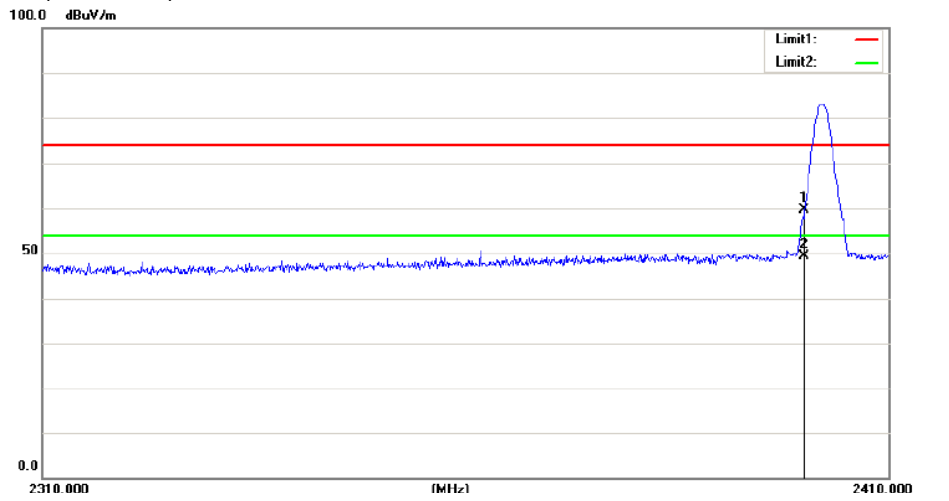

No.	Mk.	Freq.	Reading Level	Correct Factor	Measurement	Limit	Over	Detector
		MHz	dBuV	dB	dBuV/m	dBuV/m	dB	
1		2400.000	48.66	10.93	59.59	73.90	-14.31	peak
2	*	2400.000	38.57	10.93	49.50	53.90	-4.40	AVG

High Channel (Vertical):

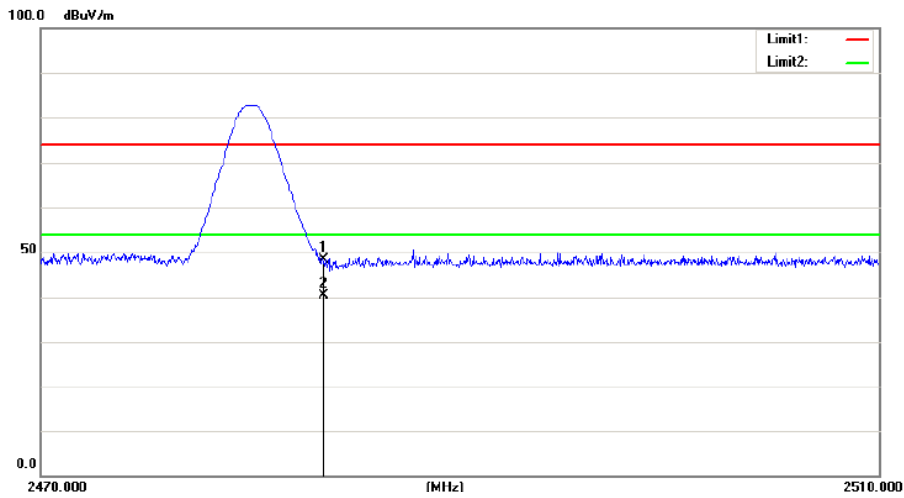

No.	Mk.	Freq.	Reading Level	Correct Factor	Measurement	Limit	Over	Detector
		MHz	dBuV	dB	dBuV/m	dBuV/m	dB	
1		2483.500	37.45	11.00	48.45	73.90	-25.45	peak
2	*	2483.500	29.50	11.00	40.50	53.90	-13.40	AVG

High Channel (Horizontal):

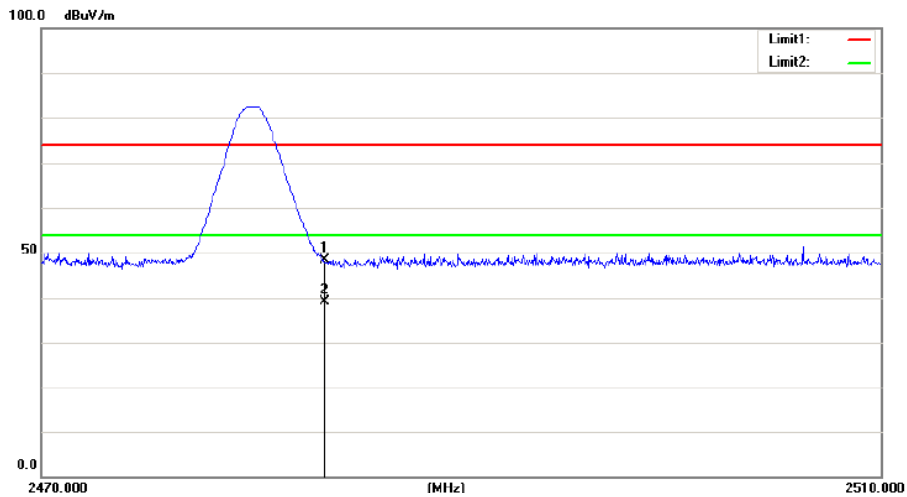

No.	Mk.	Freq.	Reading Level	Correct Factor	Measurement	Limit	Over	Detector
		MHz	dBuV	dB	dBuV/m	dBuV/m	dB	
1		2483.500	37.38	11.00	48.38	73.90	-25.52	peak
2	*	2483.500	28.20	11.00	39.20	53.90	-14.70	AVG

$\pi/4$ -DQPSK Mode

Low Channel (Vertical):

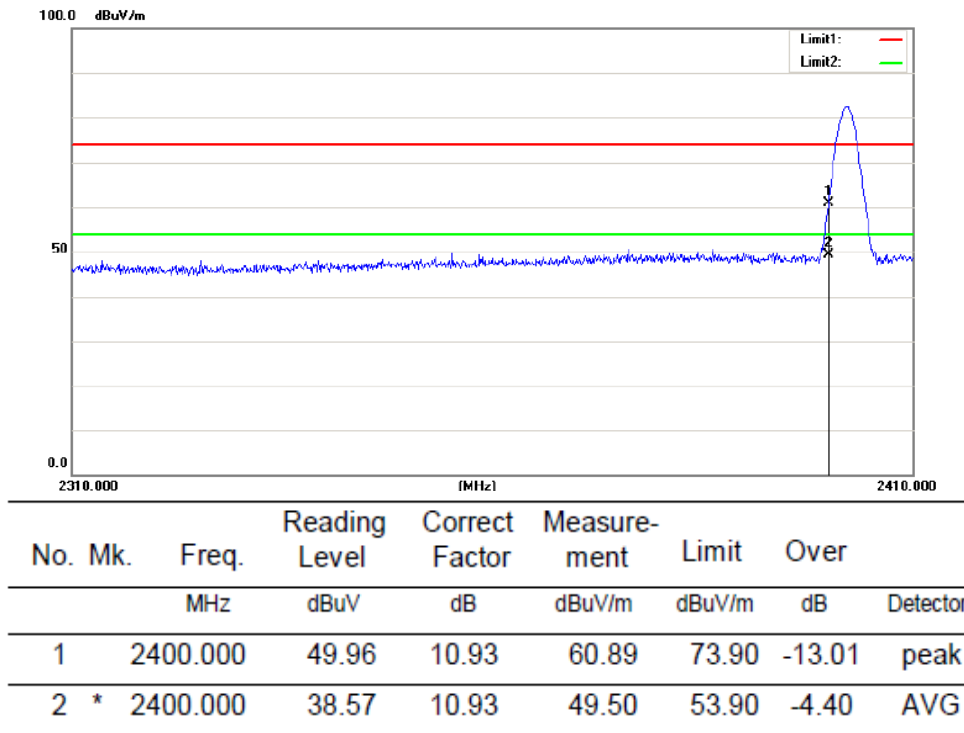

Low Channel (Horizontal):

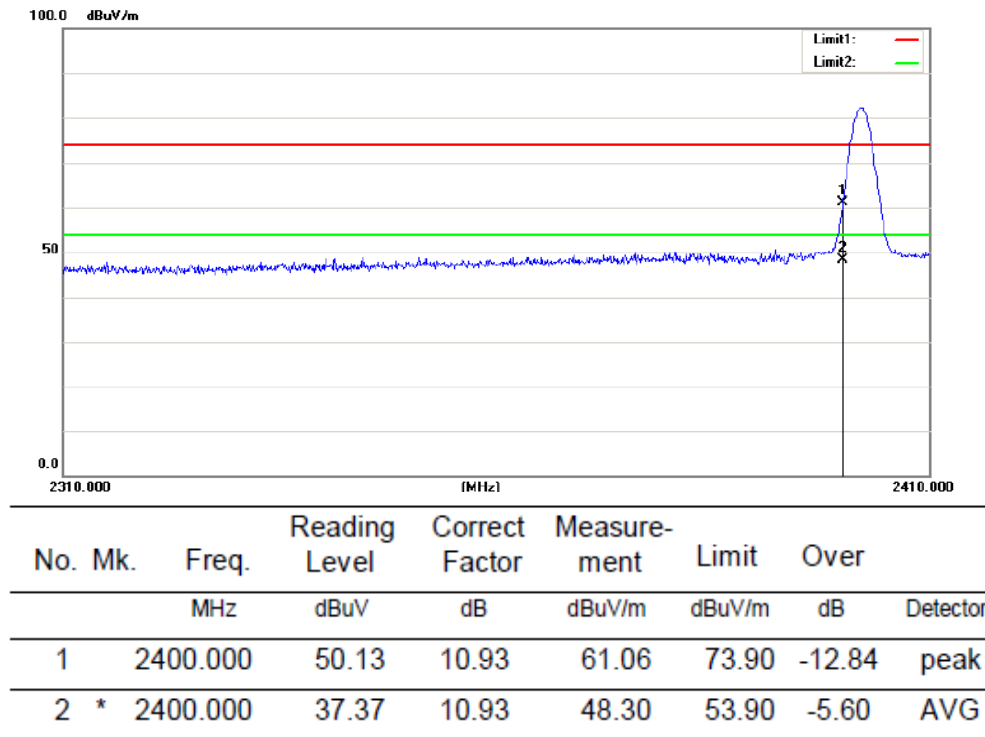

High Channel (Vertical):

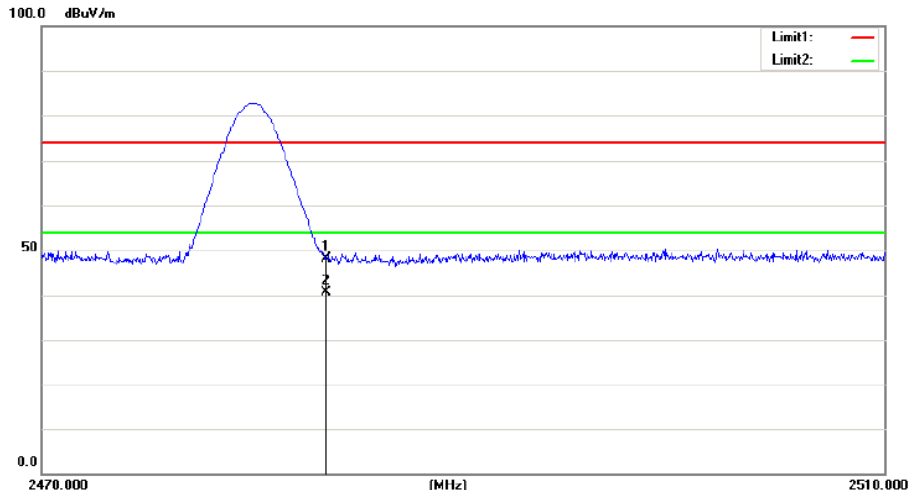

No.	Mk.	Freq.	Reading Level	Correct Factor	Measurement	Limit	Over	Detector
		MHz	dBuV	dB	dBuV/m	dBuV/m	dB	
1		2483.500	37.08	11.00	48.08	73.90	-25.82	peak
2	*	2483.500	29.60	11.00	40.60	53.90	-13.30	AVG

High Channel (Horizontal):

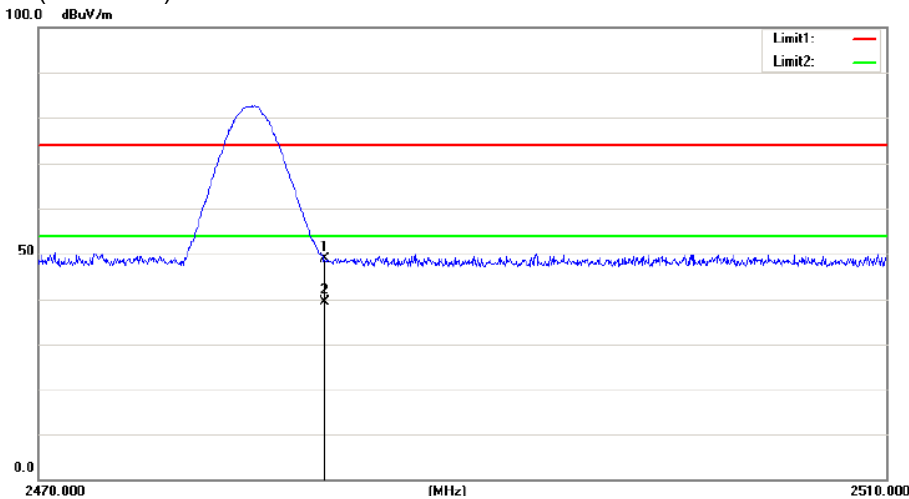

No.	Mk.	Freq.	Reading Level	Correct Factor	Measurement	Limit	Over	Detector
		MHz	dBuV	dB	dBuV/m	dBuV/m	dB	
1		2483.500	37.98	11.00	48.98	73.90	-24.92	peak
2	*	2483.500	28.40	11.00	39.40	53.90	-14.50	AVG

8DPSK Mode

Low Channel (Vertical):

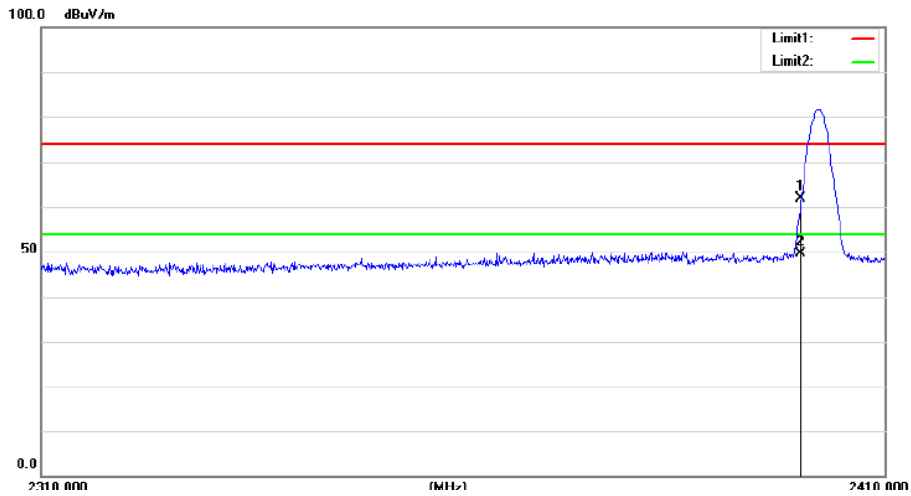

No.	Mk.	Freq.	Reading Level	Correct Factor	Measurement	Limit	Over	Detector
		MHz	dBuV	dB	dBuV/m	dBuV/m	dB	
1		2400.000	50.87	10.93	61.80	73.90	-12.10	peak
2	*	2400.000	38.67	10.93	49.60	53.90	-4.30	AVG

Low Channel (Horizontal):

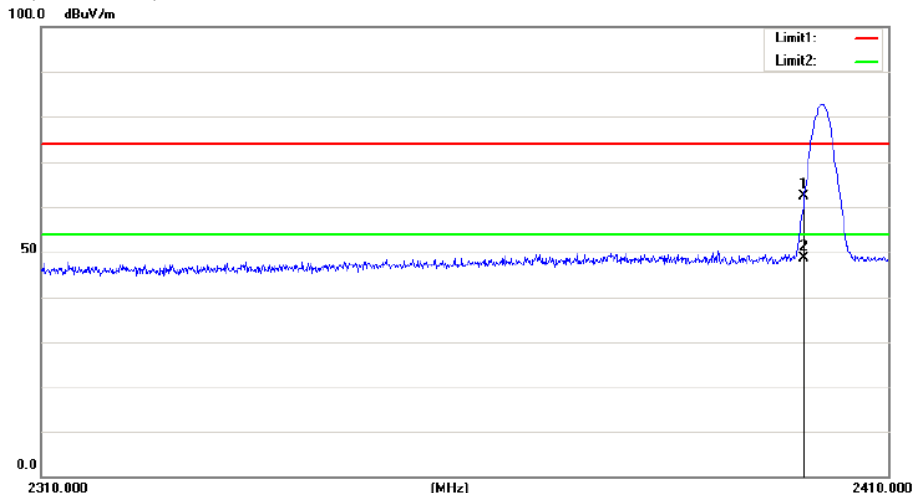

No.	Mk.	Freq.	Reading Level	Correct Factor	Measurement	Limit	Over	Detector
		MHz	dBuV	dB	dBuV/m	dBuV/m	dB	
1		2400.000	51.41	10.93	62.34	73.90	-11.56	peak
2	*	2400.000	37.77	10.93	48.70	53.90	-5.20	AVG



High Channel (Vertical):

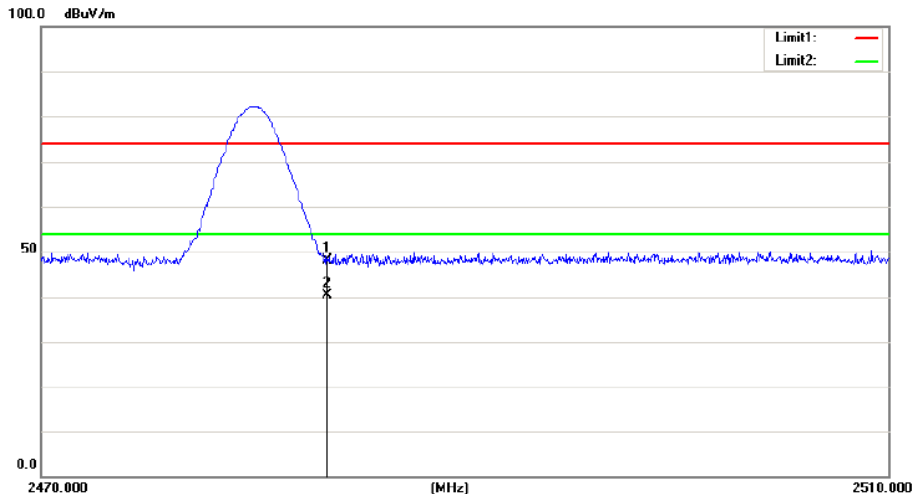

No.	Mk.	Freq.	Reading Level	Correct Factor	Measurement	Limit	Over	Detector
		MHz	dBuV	dB	dBuV/m	dBuV/m	dB	
1		2483.500	37.15	11.00	48.15	73.90	-25.75	peak
2	*	2483.500	29.40	11.00	40.40	53.90	-13.50	AVG

High Channel (Horizontal):

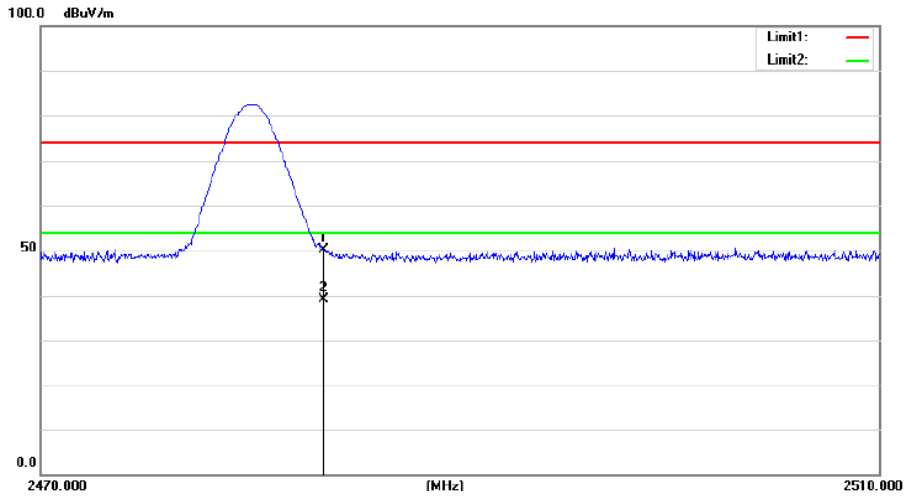

No.	Mk.	Freq.	Reading Level	Correct Factor	Measurement	Limit	Over	Detector
		MHz	dBuV	dB	dBuV/m	dBuV/m	dB	
1		2483.500	39.10	11.00	50.10	73.90	-23.80	peak
2	*	2483.500	28.10	11.00	39.10	53.90	-14.80	AVG

## 12. Antenna Port Emission

### 12.1 Test Equipment

Name of Equipment	Manufacturer	Model	Serial Number	Last Cal.	CAL DUE.
Spectrum Analyzer	Agilent	E4407B	MY45107013	05/17/2014	05/16/2015

### 12.2 Measuring Instruments and setting

The following table is the setting of spectrum analyzer.

Attenuation	Auto
RB	100kHz
VB	300kHz
Detector	Peak
Trace	Max hold

### 12.3 Test Procedures

The conducted spurious emissions were measured conducted using a spectrum analyzer at low, mid, and hi channels, the limit was determined by attenuation 20dB of the RF peak power output.

### 12.4 Block Diagram of Test setup

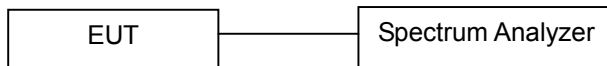

### 12.5 Test Result

PASS.

(Bluetooth (GFSK, pi/4-DQPSK, 8DPSK) mode have been tested, and the worst result(GFSK) was report as below.)

GFSK Mode: Low channel

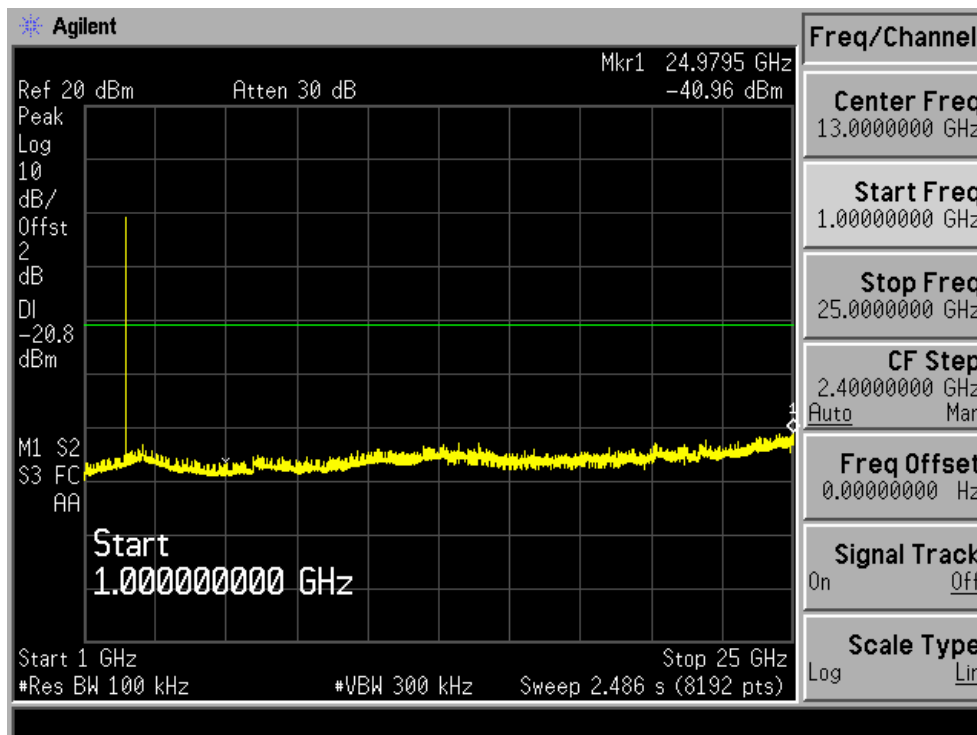
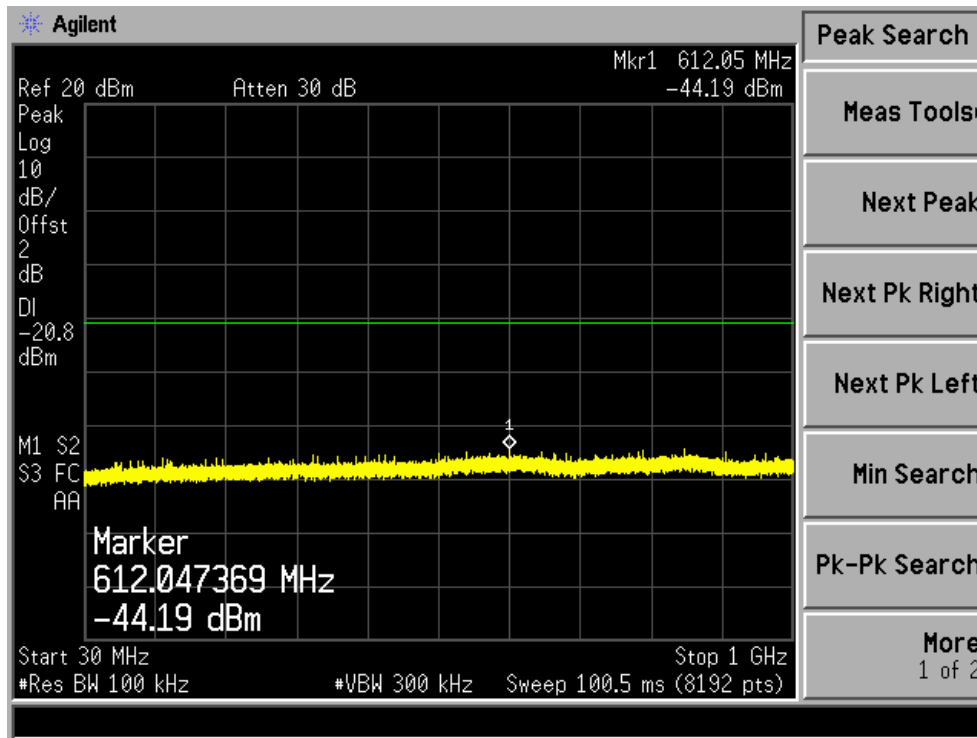

GFSK Mode: Middle channel

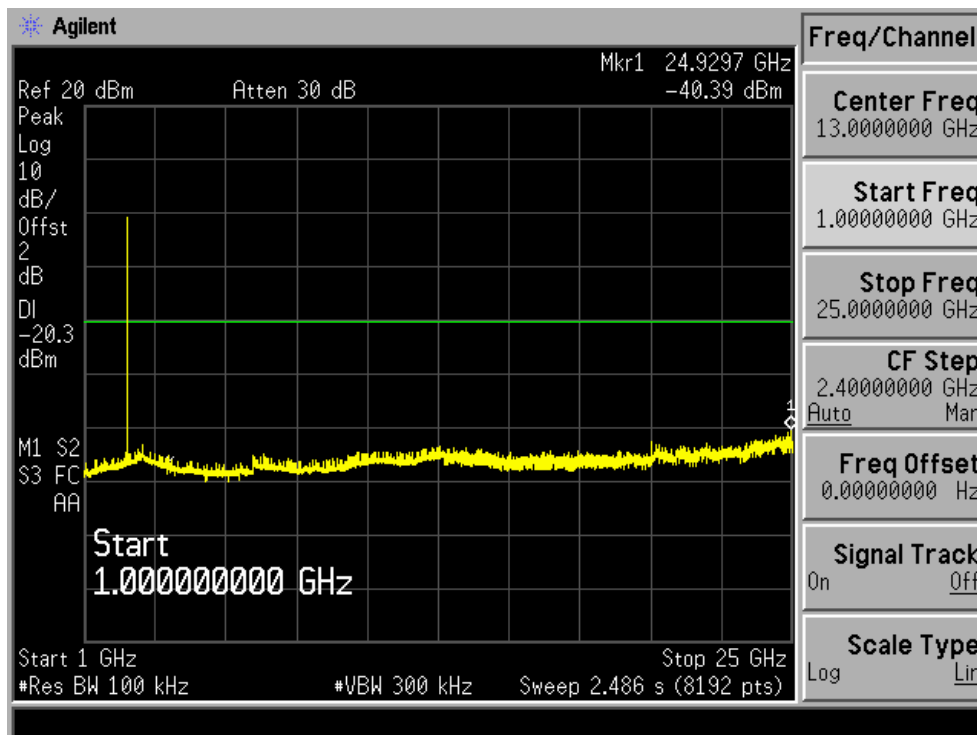
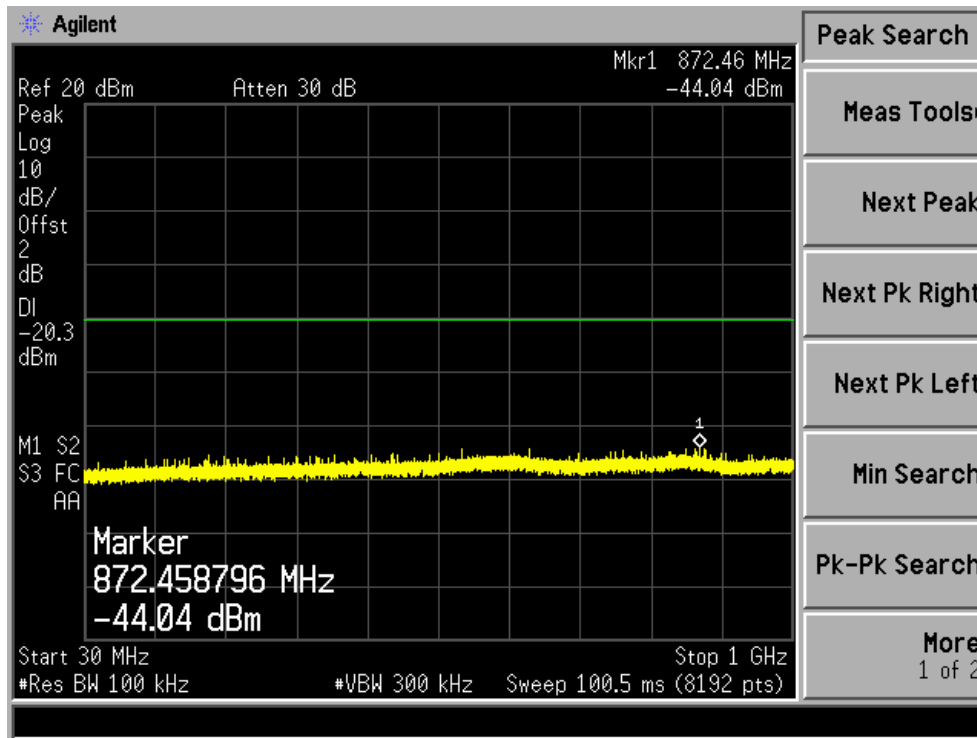

GFSK Mode: High channel

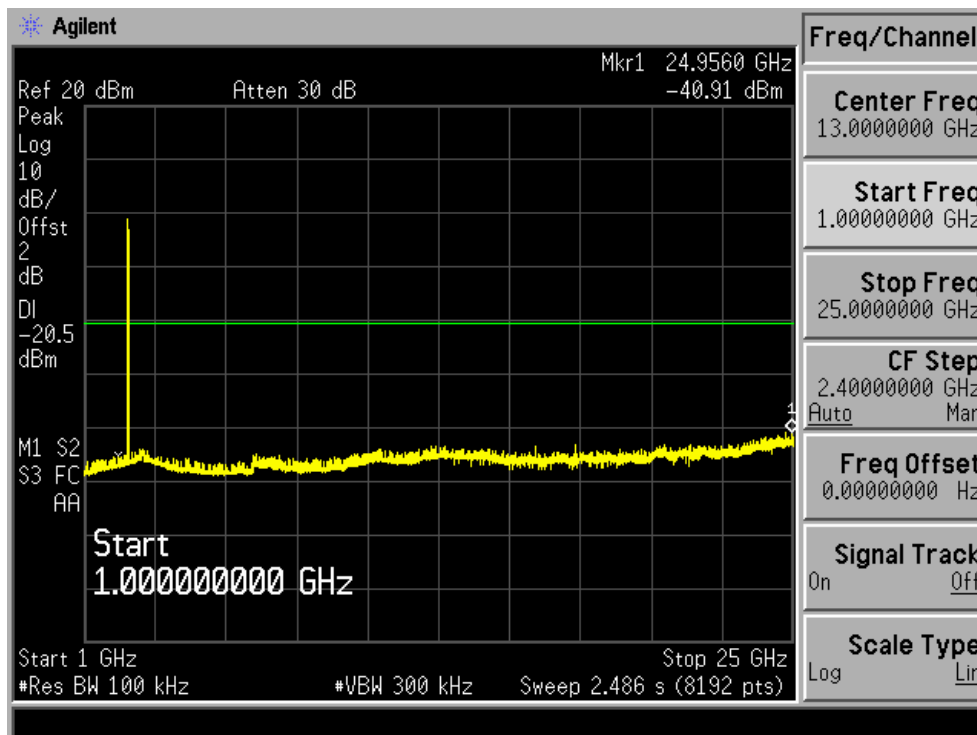
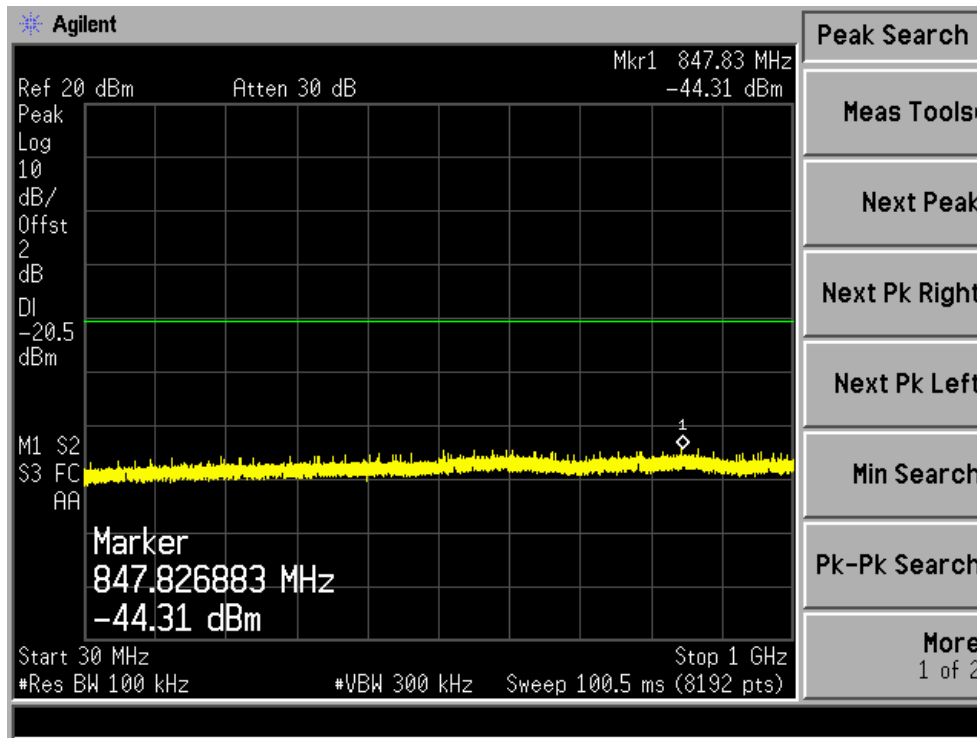

## 13. Antenna Application

### 13.1 Antenna requirement

The EUT'S antenna is met the requirement of FCC part 15C section 15.203 and 15.240.

FCC part 15C section 15.247 requirements:

Systems operating in the 2402-2480MHz band that are used exclusively for fixed, point-to-point operations may employ transmitting antennas with directional gain greater than 6dBi provided the maximum peak output power of the intentional radiator is reduced by 1dB for every 3dB that the directional gain of the antenna exceeds 6dBi.

### 13.2 Result

The EUT's antenna integrated on PCB, The antenna's gain is 0 dBi and meets the requirement

---The End---