



Party System EP-80



Quick Start Guide

CAUTION



WARNING: SHOCK HAZARD - DO NOT OPEN

AVIS: RISQUE DE CHOC ÉLECTRIQUE - NE PAS OUVRIR



The lightning flash with arrowhead symbol, within an equilateral triangle, is intended to alert the user to the presence of uninsulated "dangerous voltage" within the product's enclosure that may be of sufficient magnitude to constitute a risk of electric shock to persons.



The exclamation point within an equilateral triangle is intended to alert the user to the presence of important operating and maintenance (servicing) instructions in the literature accompanying the appliance.

Important Safety Instructions

- 1) Read these instructions.
 - 2) Keep these instructions.
 - 3) Heed all warnings.
 - 4) Follow all instructions.
 - 5) Do not use this apparatus near water.
 - 6) Clean only with dry cloth.
 - 7) Do not block any ventilation openings. Install in accordance with the manufacturer's instructions.
 - 8) Do not install near any heat sources such as radiators, heat registers, stoves, or other apparatus (including amplifiers) that produce heat.
 - 9) Do not defeat the safety purpose of the polarized or grounding-type plug. A polarized plug has two blades with one wider than the other. A grounding type plug has two blades and a third grounding prong. The wide blade or the third prong are provided for your safety. If the provided plug does not fit into your outlet, consult an electrician for replacement of the obsolete outlet.
 - 10) Protect the power cord from being walked on or pinched particularly at plugs, convenience receptacles, and the point where they exit from the apparatus.
 - 11) Only use attachments/accessories specified by the manufacturer.
 - 12) Use only with the cart, stand, tripod, bracket, or table specified by the manufacturer, or sold with the apparatus. When a cart is used, use caution when moving the cart/apparatus combination to avoid injury from tip-over.
- 
- 13) Unplug this apparatus during lightning storms or when unused for long periods of time.
 - 14) Refer all servicing to qualified service personnel. Servicing is required when the apparatus has been damaged in any way, such as power-supply cord or plug is damaged, liquid has been spilled or objects have fallen into the apparatus, the apparatus has been exposed to rain or moisture, does not operate normally, or has been dropped.

CAUTION

To prevent electric shock hazard, do not connect to mains power supply while grille is removed. minimum distances 10cm around the apparatus for sufficient ventilation; the ventilation should not be impeded by covering the ventilation openings with items, such as newspapers, table-cloths, curtains, etc.; no naked flame sources, such as lighted candles, should be placed on the apparatus; attention should be drawn to the environmental aspects of battery disposal; the use of apparatus in moderate climates. the apparatus shall not be exposed to dripping or splashing and that no objects filled with liquids, such as vases, shall be placed on the apparatus. Where the MAINS plug or an appliance coupler is used as the disconnect device, the disconnect device shall remain readily operable. Batteries (battery pack or batteries installed) shall not be exposed to excessive heat such as sunshine, fire or the like. "To reduce the risk of fire or electric shock, do not expose this apparatus to rain or moisture" Caution Marking and rating plate was located at rear enclosure of the apparatus.

CAUTION

Danger of explosion if battery is incorrectly replaced. Replace only with the same or equivalent type.

FCC warning:

This equipment has been tested and found to comply with the limits for a Class B digital device, pursuant to part 15 of the FCC Rules. These limits are designed to provide reasonable protection against harmful interference in a residential installation. This equipment generates, uses and can radiate radio frequency energy and, if not installed and used in accordance with the instructions, may cause harmful interference to radio communications. However, there is no guarantee that interference will not occur in a particular installation. If this equipment does cause harmful interference to radio or television reception, which can be determined by turning the equipment off and on, the user is encouraged to try to correct the interference by one or more of the following measures:

- Reorient or relocate the receiving antenna.
- Increase the separation between the equipment and receiver.
- Connect the equipment into an outlet on a circuit different from that to which the receiver is connected.
- Consult the dealer or an experienced radio/TV technician for help.

Caution: Any changes or modifications to this device not explicitly approved by manufacturer could void your authority to operate this equipment. This device complies with part 15 of the FCC Rules. Operation is subject to the following two conditions: (1) This device may not cause harmful interference, and (2) this device must accept any interference received, including interference that may cause undesired operation.

RF Exposure Information

This equipment complies with FCC radiation exposure limits set forth for an uncontrolled environment. This equipment should be installed and operated with minimum distance 20cm between the radiator and your body.

PANEL

1. FM Antenna
2. DC INPUT
3. MIC: Wired Mic input socket
4. GUITAR: Guitar input socket
5. LINE-IN: Line-in input socket

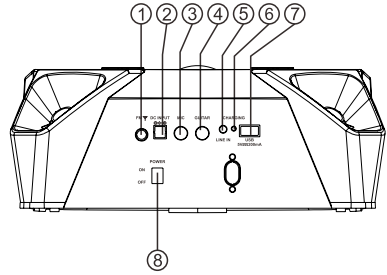

6. Charging Light
7. USB: USB input socket
Important: The USB port is intended only for data transfer only, other devices cannot be used with this USB connection. The use of USB extension cords is not recommended.
8. POWER SWITCH: Press this switch to turn the unit ON or OFF

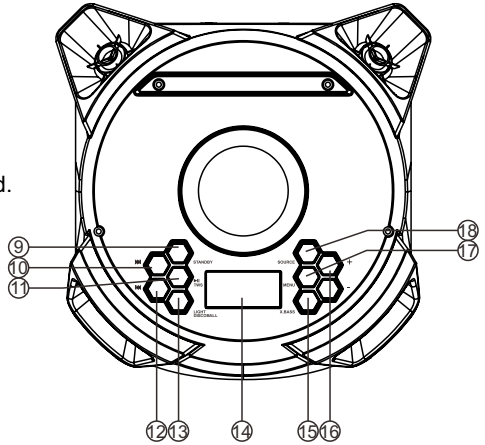

9. STANDBY: Press to Standby ON or OFF.
10. ►►: To play the next song at USB/BT input mode.
11. FM auto -scan/►►/TWS: In FM mode, press for the fully automatic search. Press to PLAY/PAUSE a track at USB/BT input mode. Press and hold on to change the TWS (true wireless stereo) mode on or off.
12. ◀◀: To play the previous song at USB/BT input mode.
13. LIGHT/DISCOBALL : Press to change the front speaker light mode between ON or OFF. Hold this key to DISOBALL on or off.
14. LED DISPLAY: To display speaker status.
15. X.BASS: Press the key to turn the extra bass effect ON/OFF.
16. VOLUME +/-: To adjust the levels.
17. MENU: Press this key to change the menu between MIC, GUITAR, VOLUME, ECHO VOLUME, BASS, TREBLE.
18. SOURCE: Press this key to change the sources between USB, BT, FM, LINE.

REMOTE CONTROL

1. **STANDBY** : Stand by ON/OFF key.
2. **0~9 NUMERIC KEYS**: These keys are used to play a track directly in USB source mode.
Eg: To play 12th track in the USB playlist press the numeric key "1" followed by "2".
3. **VOL-** : To decrease the volume.
4. **⏮/CH-**: Play the previous song by pressing "⏮/CH-" at USB/BT input mode. Choose previous channel by pressing "⏮ /CH-" at FM input mode.
5. **⏸**: Play / pause in USB/BT mode. In FM mode press for the full automatic search.
6. **⏮/TU-** : Fast rewind a song by pressing "⏮/TU-" at USB input mode. Choose tuning channel by pressing "⏮/TU-" at FM input mode.
7. **⏭/TU+** : -fast forward song by pressing "⏭/TU+" at USB input mode. Choose tuning channel by pressing "⏭/TU+" at FM input mode.
8. **⏭/CH+** : Play the next song by pressing "⏭/CH+" at USB/BT input mode. Choose next channel by pressing "⏭/CH+" at FM input mode.
9. **VOL+** : To increase the volume.
10. **MUTE** : Press to toggle the volume Mute ON/OFF.
11. **REPEAT** : Choose repeat mode by pressing "REPEAT" at USB input mode.
12. **SOURCE** : press this key to change the source between USB, BT, FM, AUX.

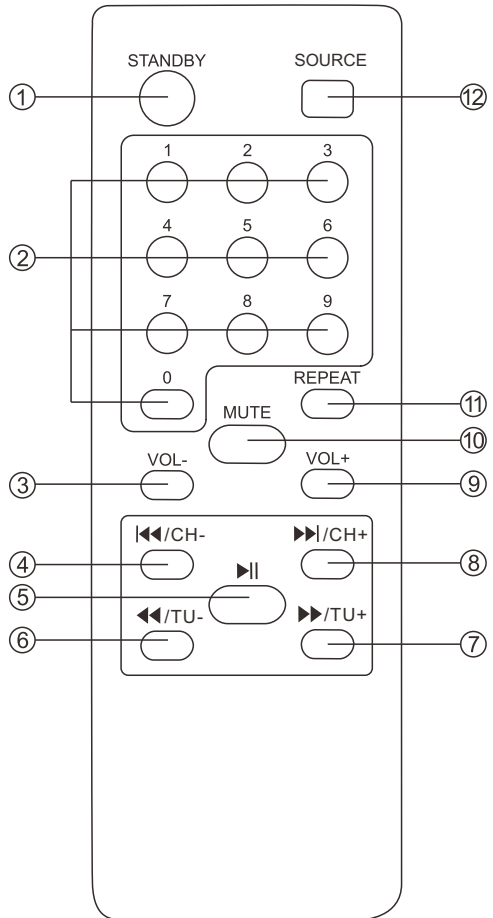

NOTE: The remote receiver is at the top side of front speaker panel.

Bluetooth pair and connect

- Turn off any Bluetooth devices previously paired (linked) with this unit.
- Turn on the Bluetooth feature on your phone or music player.
- Turn on and set this unit to Bluetooth mode. The flashing "bt" on LED display indicates it is in pairing mode.
- Set your phone or music player to search for Bluetooth devices.
- Select "Party System EP-80" from search results on your phone or music player.
- Select OK or YES to pair this unit with your phone or music player.
- If protected, enter 0000 for passkey steady blue light indicates successful connection.
- Hold pair key to disconnect current connection and enter pairing mode.

TWS (True Wireless Stereo) mode

1. Turn on 2 speaker equipments and select both unit INPUT mode as Bluetooth
2. Press "TWS" key on speaker set for 2 seconds, it will show "bt" on display, TWS is connecting to another speaker equipment and will connect successfully after a sound indication or display shows "bt"
3. Turn on your Bluetooth feature on your mobile phone to search Bluetooth devices and select "Party System EP-80" from the search result, select OK or YES to pair this unit with your mobile phones and a steady blue light will indicate the connection is successful and can play any music from your mobile phones.
4. Press "TWS" key on speaker unit for 2 seconds and it will turn off TWS features after shows "bt" on display.
(The "LEFT" channel will be the speaker A, the other speaker will be the "RIGHT" channel.)

FM Radio Operation

1. Before using the radio functions, you must attach the supplied antenna. Adjust the antenna to obtain optimum reception.
Press [SOURCE] repeatedly to select FM mode.
2. Press the CH+/CH- key on the remote control or Hold the key "◀▶" on the top panel to skip to the preset station.
3. Press the TU+/TU- key on the remote control or press the key "◀▶" on the top panel to adjust the radio frequency manually.
The number key on the remote control can directly select the frequency. Such as enter "8,8,1" keys for 88.1MHz, "1,0,4,0" keys for 104.0MHz.
4. Press the PLAY key on the remote control or Press the key "▶" on the top panel, the machine will scan radio channels from low-frequency to high-frequency by itself and memorize the channels one by one.

BATTERY

In AC (power) mode the battery will automatically charge. A slow red flashing light indicates that the battery is charging. When fully charged a green light will be displayed.

In DC (battery) mode a green light indicates that the battery level is full. If the battery level is low a red light will be displayed. This indicates that the battery must immediately be charged or the speaker will turn off.

In use please pay attention to the following items:

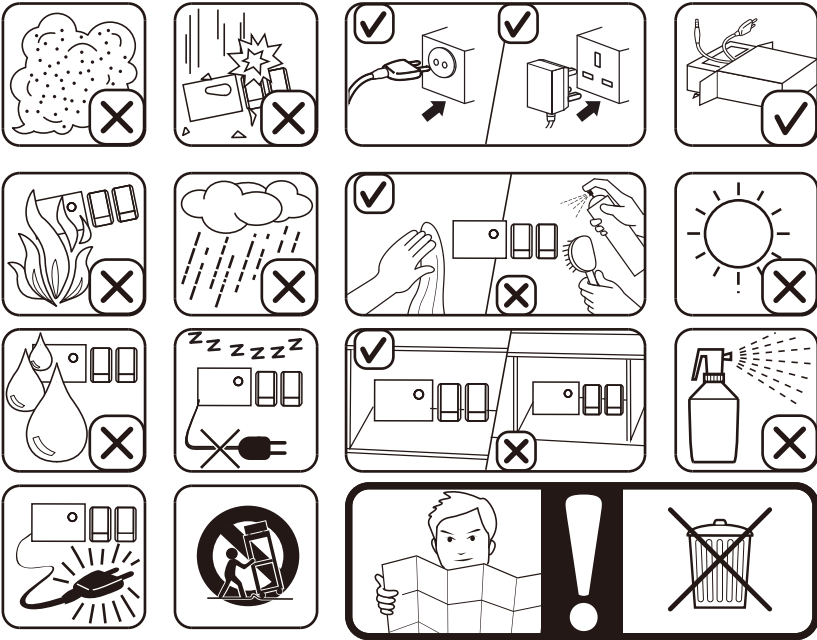

Accessories

- Instruction Manual -----1 pc
- Remote control-----1 pc
- FM Antenna-----1 pc
- Power cable-----1 pc

Specifications

- Frequency Response ----- 30Hz -20kHz
- FM Frequency -----87.5-108MHz
- Power Source -----AC 100-240V~,60/50Hz
- Power Consumption -----80W

Due to continuous product development specifications and functions may be changed without prior notice.



CAUTION

- The apparatus shall not be exposed to dripping or splashing and that no objects filled with liquids, such as vases, shall be placed on the apparatus.
- Minimum distances 10 cm around the apparatus for sufficient ventilation.
- The ventilation should not be impeded by covering the ventilation openings with items, such as newspapers, table-cloths, curtains, etc.
- No naked flame sources, such as lighted candles, should be placed on the apparatus.
- When the mains plug or an appliance coupler is used as the disconnect device, the disconnect device shall remain readily operable. To be completely disconnected the power input, the mains plug of apparatus shall be disconnected from the mains completely.
- The main plug of apparatus should not be obstructed or should be easily accessed during intended use.
- The use of apparatus in tropical climates.
- Attention should be drawn to the environmental aspects of battery disposal.
- Batteries shall not be exposed to excessive heat such as sunshine, fire or the like.
- Excessive sound pressure from earphones and headphones can cause hearing loss.



CAUTION
RISK OF ELECTRIC SHOCK
DO NOT OPEN



This unit contains no user serviceable parts inside.
Do not attempt to repair the unit yourself.
Please refer servicing to a qualified service personnel.



Limited Warranty

This Limited Product Warranty is provided by BriteLite Enterprises. BriteLite warrants to Customer that the product is free from defects in materials and workmanship under normal use during the Warranty Period of 90 days for parts and 1-year labor. If the product fails to conform to the warranty then BriteLite or its authorized service will either repair or replace any nonconforming product, provided that Customer gives notice of noncompliance within the Warranty Period to BriteLite by emailing service@britelite.net or calling 310-363-7110 (Mexico customers can call 01554624 0251). Please retain the original dated receipt as evidence of proof of purchase.

