



849 NW STATE ROAD 45
 NEWBERRY, FL 32669 USA
 PH: 888.472.2424 OR
 352.472.5500
 FAX: 352.472.2030
 EMAIL: INFO@TIMCOENGR.COM
[HTTP:// WWW.TIMCOENGR.COM](http://WWW.TIMCOENGR.COM)

**FCC PART 95 SUBPART D
 & IC RSS-236 (issue 1)
 CB TRANSCEIVER
 TEST REPORT**

APPLICANT	PRESIDENT ELECTRONICS USA
	1004 COLLIER CENTER WAY SUITE 206 NAPLES, FL 34110 USA
FCC ID	2AEOCUT411
IC	20240-UT411
MODEL NUMBER	JOHNNY III USA
PRODUCT DESCRIPTION	CB TRANSCEIVER
DATE SAMPLE RECEIVED	10/26/2015
FINAL TEST DATE	12/30/2015
TESTED BY	Tim Royer
APPROVED BY	Cory Leverett
TEST RESULTS	<input checked="" type="checkbox"/> PASS <input type="checkbox"/> FAIL

Report Number	Version Number	Description	Issue Date
2245ZAUT15TestReport	Rev1	Initial Issue	12/30/2015

**THE ATTACHED REPORT SHALL NOT BE REPRODUCED EXCEPT IN FULL
 WITHOUT THE WRITTEN APPROVAL OF TIMCO ENGINEERING, INC.**



TABLE OF CONTENTS

GENERAL REMARKS	3
GENERAL INFORMATION	4
TEST SETUP SUMMARY.....	5
TEST RESULTS SUMMARY.....	5
RF POWER OUTPUT.....	6
MODULATION CHARACTERISTICS.....	7
OCCUPIED BANDWIDTH	10
SPURIOUS EMISSIONS AT ANTENNA TERMINALS (CONDUCTED)	14
FIELD STRENGTH OF SPURIOUS EMISSIONS	17
FREQUENCY STABILITY	20
EQUIPMENT LIST.....	21

APPLICANT: PRESIDENT ELECTRONICS USA
FCC ID: 2AEOCUT411
IC: 20240-UT411
REPORT #: 2245ZAUT15TestReport_Rev1

GENERAL REMARKS

The attached report shall not be reproduced except in full without the written permission of Timco Engineering Inc.

The test results relate only to the items tested.

Summary

The device under test does:

- Fulfill the general approval requirements as identified in this test report
- Not fulfill the general approval requirements as identified in this test report

Attestations

This equipment has been tested in accordance with the standards identified in this test report. To the best of my knowledge and belief, these tests were performed using the measurement procedures described in this report.

All instrumentation and accessories used to test products for compliance to the indicated standards are calibrated regularly in accordance with ISO 17025 requirements.

I attest that the necessary measurements were made, under my supervision, at:

**Timco Engineering Inc.
849 NW State Road 45
Newberry, FL 32669**

Authorized Signatory Name:



Tim Royer
Engineering Project Manager

Date: 12/30/2015

[Table Of Contents](#)

APPLICANT: PRESIDENT ELECTRONICS USA
FCC ID: 2AEOCUT411
IC: 20240-UT411
REPORT #: 2245ZAUT15TestReport_Rev1



GENERAL INFORMATION

EUT Specification

EUT Description	CB TRANSCEIVER
FCC ID	2AEOCUT411
IC	20240-UT411
Model Number	JOHNNY III USA
Serial Number	N/A
Operating Frequency	26.965-27.405 MHz – 40 Channel
No. of Channels	40
Type of Emission	6KOA3E Bn = 2M M = 3000 Bn = 6000
Modulation	A3E
EUT Power Source	<input type="checkbox"/> 110–120Vac/50– 60Hz
	<input checked="" type="checkbox"/> DC Power
	<input type="checkbox"/> Battery Operated Exclusively
Test Item	<input type="checkbox"/> Prototype
	<input checked="" type="checkbox"/> Pre-Production
	<input type="checkbox"/> Production
Type of Equipment	<input type="checkbox"/> Fixed
	<input checked="" type="checkbox"/> Mobile
	<input type="checkbox"/> Portable
Applicable Standards	FCC CFR 47 PART 2,95, RSS-GEN ISSUE 4, RSS-236 ISSUE 1
Test Facility	Timco Engineering, Inc. 849 NW State Road 45 Newberry, FL 32669 USA.
Test Condition in the laboratory	Temperature: 24-26°C Relative humidity: 50 - 65%

APPLICANT: PRESIDENT ELECTRONICS USA
 FCC ID: 2AEOCUT411
 IC: 20240-UT411
 REPORT # : 2245ZAUT15TestReport_Rev1

TEST SETUP SUMMARY

Deviation from the standard/ procedure	No deviation
Modification of EUT	No modification
Measurement Standards	EIA/TIA-603-D, ANSI C63.4-2009 (RADIATED SITE VALIDATION) ANSI C63.10-2013 FCC CFR 47 PART 2,95, RSS-GEN ISSUE 4, RSS-236 ISSUE 1

TEST RESULTS SUMMARY

Requirement	FCC Rule Part	IC RSS	RESULTS
Power Output	2.1046(b)(6) 95.639(c)(1)	236 § 5.2 GEN § 6.12	Pass
Modulation Characteristics	2.1047(a)(b) 90.637(c)	236 § 5.3.2	Pass
Occupied Bandwidth	2.1049(c)(1) 95.633(a) 95.635(b)(1)(3)	236 § 5.3.2 236 § 5.4.1 GEN § 6.6	Pass
Spurious Emissions at Antenna Terminals	2.1051(a) 95.635(b)(8)(9)	236 § 5.4.4 236 § 5.4.1 GEN § 6.13	Pass
Field Strength of Spurious Emissions	2.1053(a)(b) 95.635(b)(8)(9)	236 § 5.4.4 236 § 5.4.1 GEN s 6.13	Pass
Frequency Stability	2.1055 95.625(b)	GEN § 6.11	Pass

[Table Of Contents](#)

APPLICANT: PRESIDENT ELECTRONICS USA
 FCC ID: 2AEOCUT411
 IC: 20240-UT411
 REPORT # : 2245ZAUT15TestReport_Rev1

RF POWER OUTPUT

FCC Rule Part No: 2.1046(b)(6), 95.639(c)(1)

IC RSS: 236 § 5.2, GEN § 6.12

Limit: 4 W Carrier power when transmitting emission type A1D or A3E

Procedure: TIA 382-A § 19.2 Transmitter Carrier Power Output
IC RSS 236 § 5.1 Meas for Single-Sideband Transmitters

Setup:

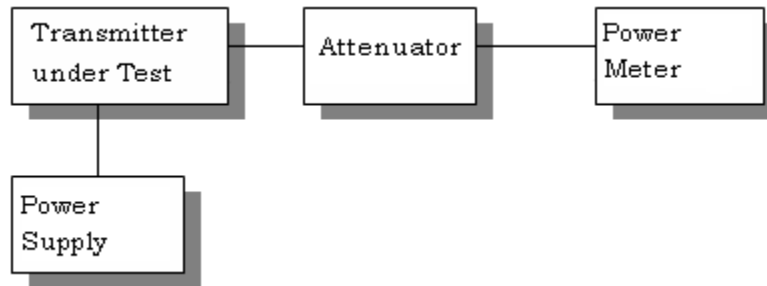

Test Data:

Power Output Measurement Table

	Output Power	Margin
Channel	W	W
Ch1	3.16	0.84
Ch 20	3.16	0.84
Ch 40	3.06	0.94

Part 2.1033 (C) (8) DC Input into the final amplifier

INPUT POWER: (13.8V) (1.17A) = 16.146 Watts

Results Meet Requirements

[Table Of Contents](#)

MODULATION CHARACTERISTICS

FCC Rule Part No: 2.1047(a)(b), 95.637 (c)

IC RSS: 236 § 5.3.2

Limit: When emission type A3E is transmitted by a CB transmitter having a total power of greater than 2.5 W, the CB transmitter must automatically prevent the modulation from exceeding 100%.

A curve or equivalent data showing the frequency response of the audio modulating circuit over a range of 100 – 10000 Hz shall be submitted.

Procedure: TIA 603-D § 2.2.3 Transmitter Modulation Limiting
TIA 603-D § 2.1.10 Transmitter Audio Frequency Response

Setup

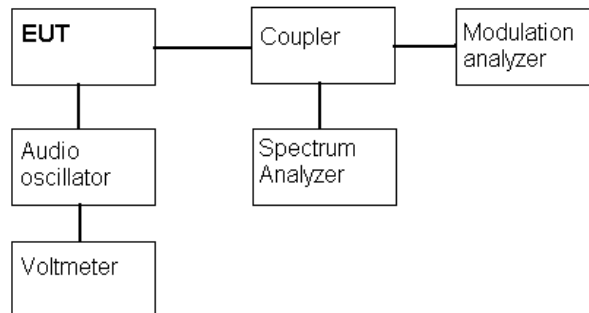

[Table Of Contents](#)

MODULATION CHARACTERISTICS

Test Data: Modulation Limiting Plot

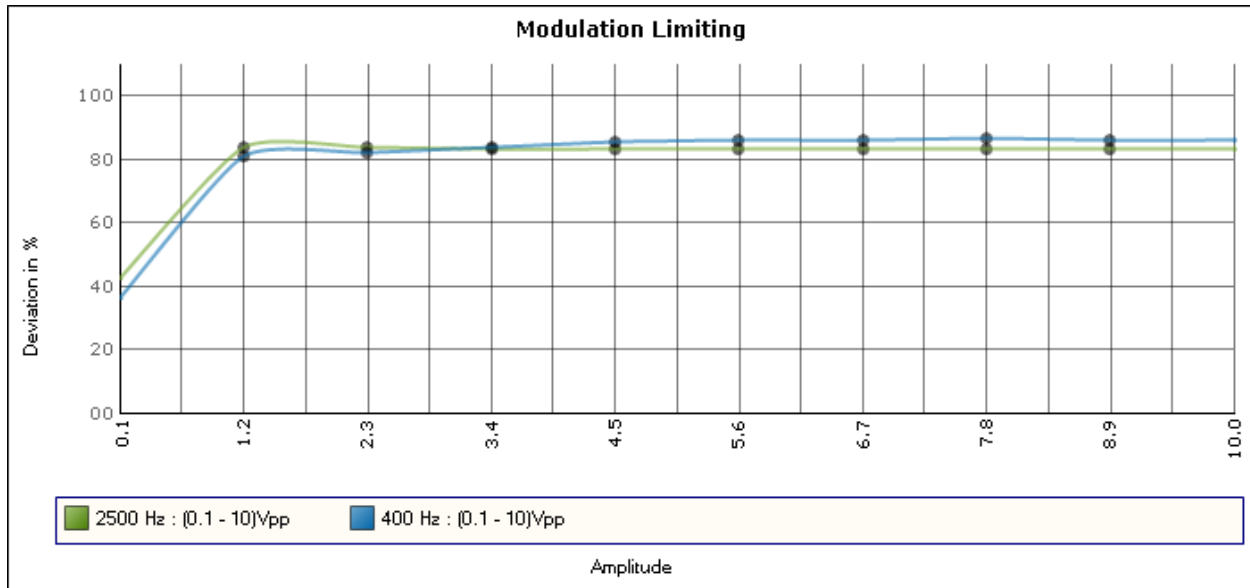

Results Meet Requirements

MODULATION CHARACTERISTICS

Test Data: 100 Hz ~ 10KHz Audio Response Curve Plot

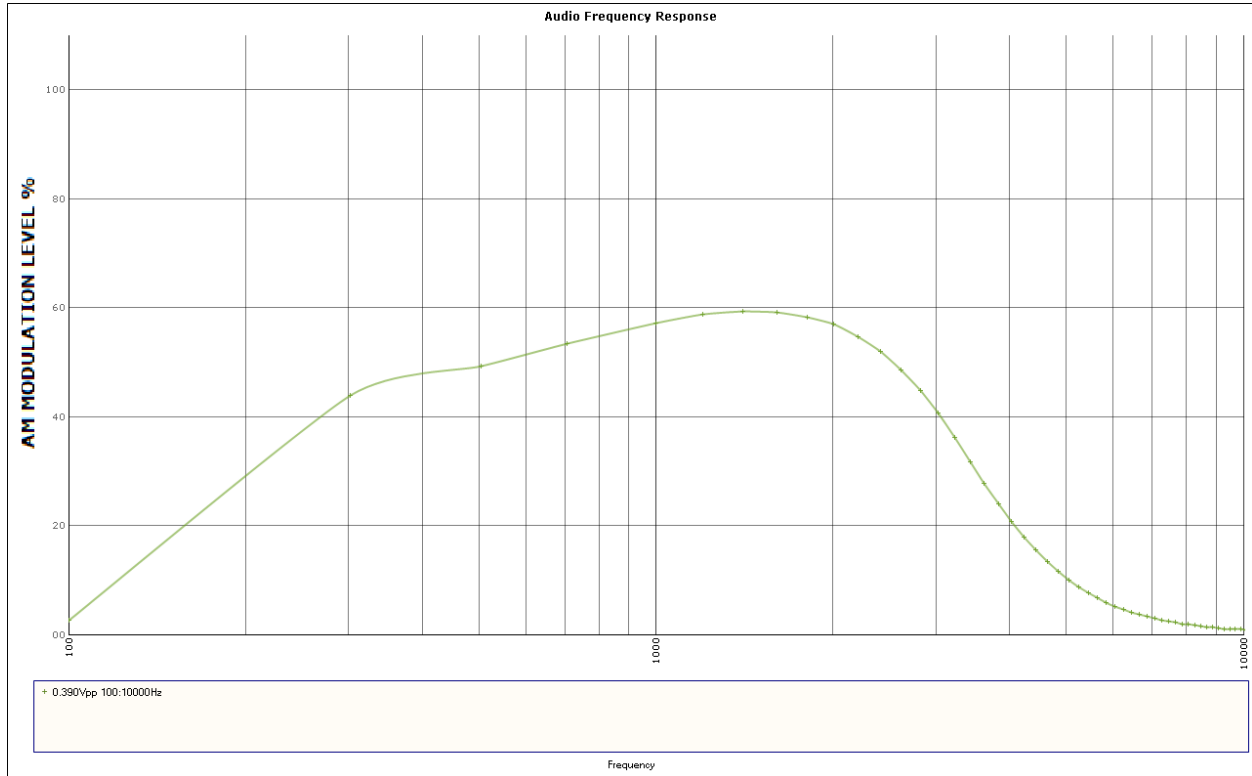

Results are for reporting Only

[Table Of Contents](#)

APPLICANT: PRESIDENT ELECTRONICS USA
FCC ID: 2AEOCUT411
IC: 20240-UT411
REPORT # : 2245ZAUT15TestReport_Rev1

OCCUPIED BANDWIDTH

FCC Rules Part No.: 95.633 (a), 95.635 (b)(1)(3)

IC RSS: 236 § 5.3.2, GEN 6.6

Limit: The authorized bandwidth (maximum permissible bandwidth of a transmission) for emission type A3E is 8 kHz

The power of each unwanted emission shall be less than Transmitter Power by At least 25 dB (decibels) on any frequency removed from the center of the authorized bandwidth by more than 50% up to and including 100% of the authorized bandwidth.

The power of each unwanted emission shall be less than Transmitter Power by at least 35 dB on any frequency removed from the center of the authorized bandwidth by more than 100% up to and including 250% of the authorized bandwidth.

Procedure: TIA 603-D § 2.2.11 Transmitter Side Band Spectrum
ANSI C63.10 § 6.9.3 99% Bandwidth procedure
IC RSS 236 § 5.4.1 Single-Sideband Transmitters
IC RSS 236 § 5.4.3 Minimum Standards

Setup:

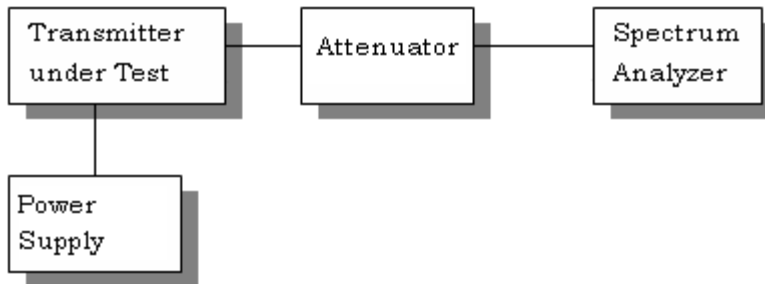

Test Data: 99% Emission Bandwidth Measurement

Tuned Frequency (MHz)	99% (KHz)	Limit (KHz)	Margin (KHz)
CH 1	5.53	8.0	2.47
CH 20	5.47	8.0	2.53
CH 40	5.47	8.0	2.53

Results Meet Requirements

[Table Of Contents](#)

APPLICANT: PRESIDENT ELECTRONICS USA
 FCC ID: 2AEOCUT411
 IC: 20240-UT411
 REPORT # : 2245ZAUT15TestReport_Rev1

Test Data:

Test Data: Emission Mask Low end of Band

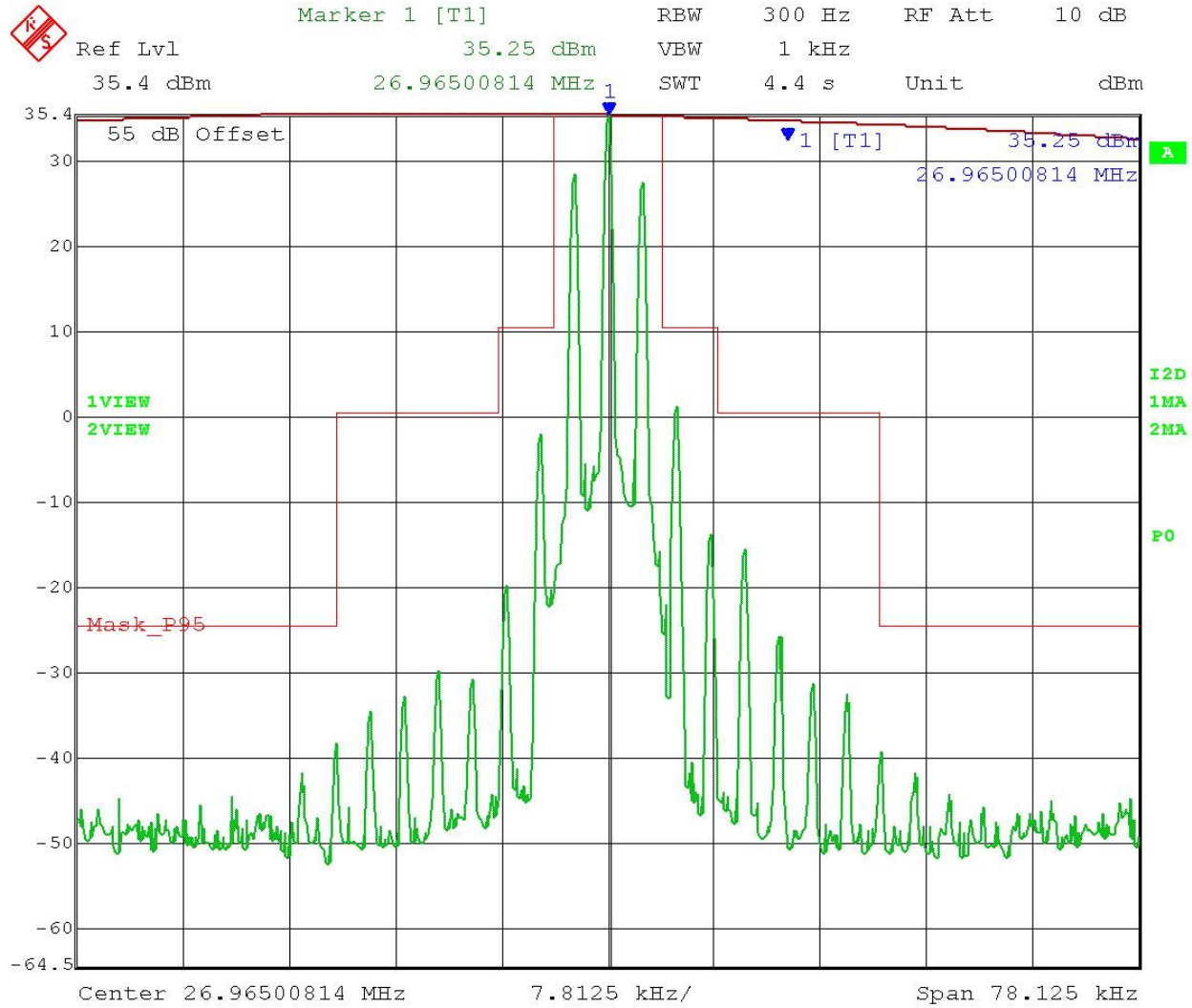

Date: 12.NOV.2015 16:07:02

Results Meet Requirements

[Table Of Contents](#)

APPLICANT: PRESIDENT ELECTRONICS USA
 FCC ID: 2AEOCUT411
 IC: 20240-UT411
 REPORT #: 2245ZAUT15TestReport_Rev1

Test Data: Emission Mask Middle of Band

	Marker 1 [T1]	RBW	300 Hz	RF Att	10 dB
	Ref Lvl	30.65 dBm	VBW	1 kHz	
	35.2 dBm	27.20525426 MHz	SWT	4.4 s	Unit dBm

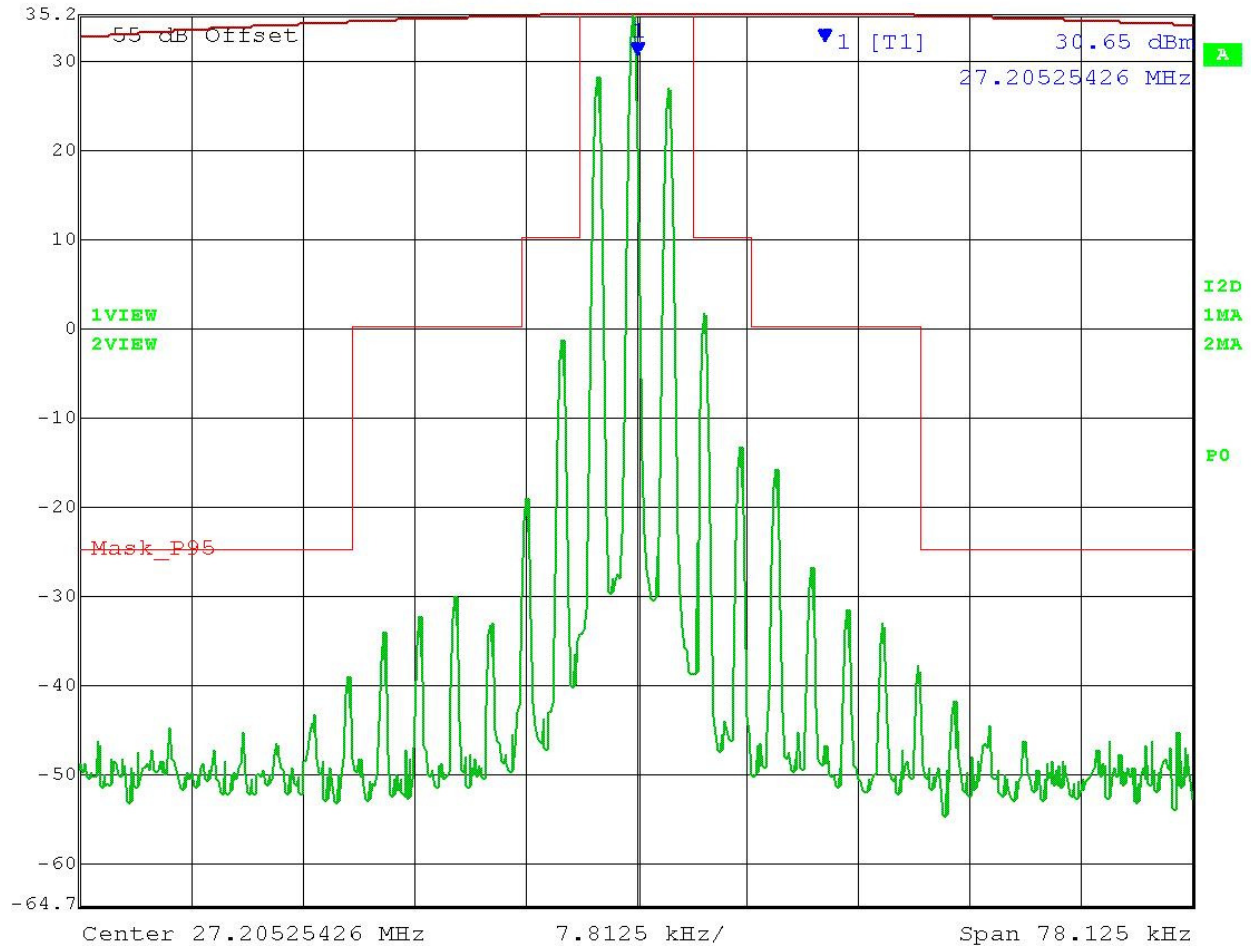

Date: 12.NOV.2015 16:03:47

Results Meet Requirements

[Table Of Contents](#)

APPLICANT: PRESIDENT ELECTRONICS USA
 FCC ID: 2AEOCUT411
 IC: 20240-UT411
 REPORT #: 2245ZAUT15TestReport_Rev1

Test Data: Emission Mask High end of Band



Ref Lvl
35 dBm

RBW 300 Hz RF Att 10 dB
 VBW 1 kHz
 SWT 4.4 s Unit dBm

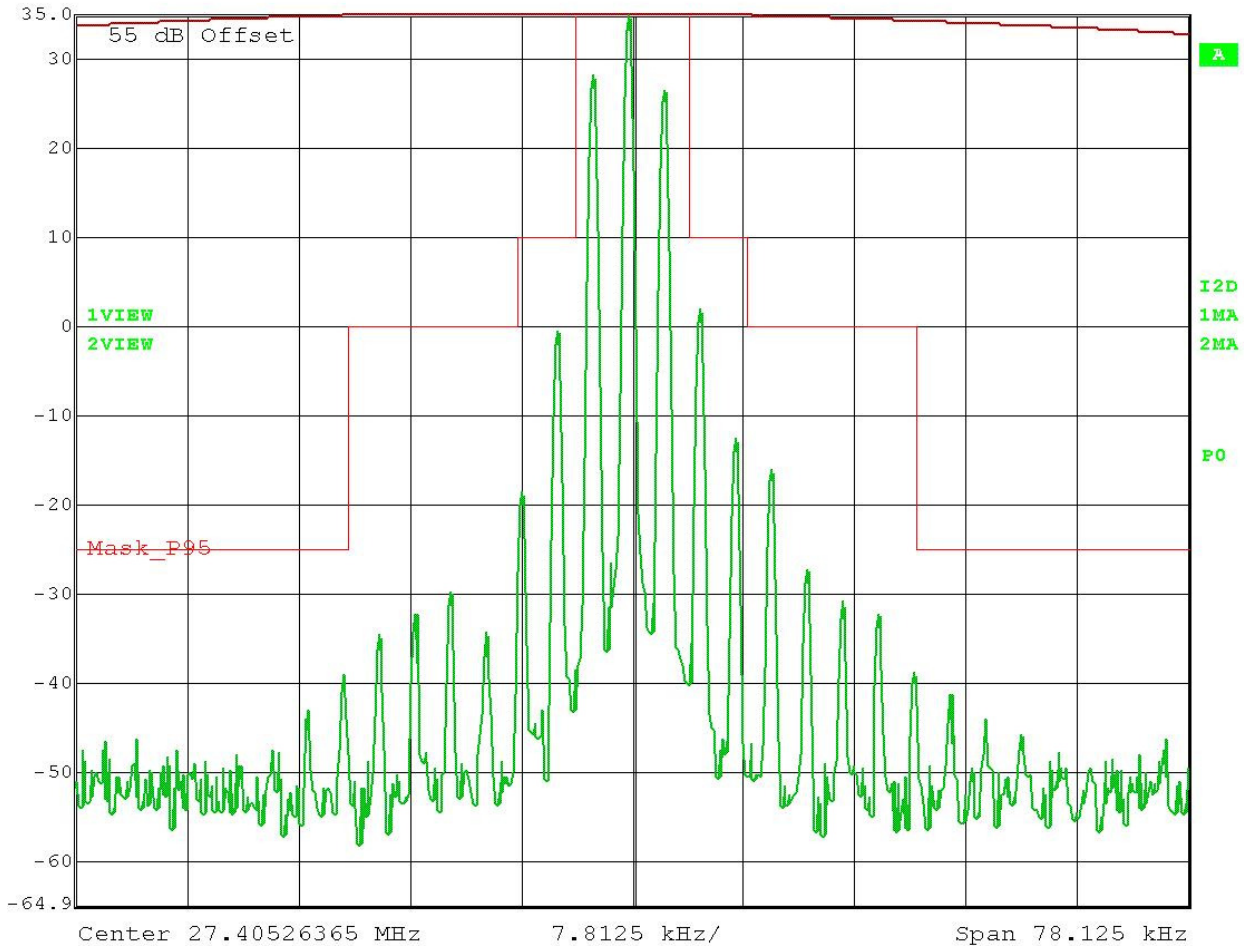

Date: 12.NOV.2015 15:59:21

Results Meet Requirements

[Table Of Contents](#)

APPLICANT: PRESIDENT ELECTRONICS USA
 FCC ID: 2AEOCUT411
 IC: 20240-UT411
 REPORT #: 2245ZAUT15TestReport_Rev1

SPURIOUS EMISSIONS AT ANTENNA TERMINALS (CONDUCTED)

FCC Rule Part No: 2.1051(a), 95.635 (b)(8)(9)

IC RSS: 236 § 5.4.4, GEN § 6.13

Limit: The power of each unwanted emission shall be less than Transmitter Power at least $53 + 10 \log_{10} (T)$ dB on any frequency removed from the center of the authorized bandwidth by more than 250%.

In addition the power of each unwanted emission shall be less than Transmitter Power at least 60 dB on any frequency twice or greater than twice the fundamental frequency.

Procedure: TIA 603-D § 2.2.13 Transmitter Conducted Spurious Emissions
 IC RSS 236 § 5.4.1 Single-Sideband Transmitters
 IC RSS 236 § 5.4.3 Minimum Standards

Setup:

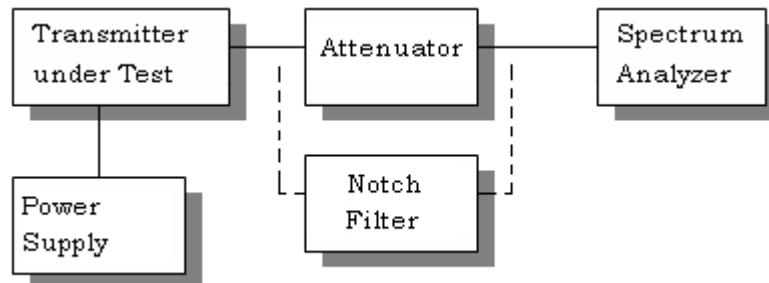

[Table Of Contents](#)



SPURIOUS EMISSIONS AT ANTENNA TERMINALS (CONDUCTED)

Test Data: Low end of Band Ch 1 – 26.965 MHz

Modulated	dBm	Watts	Limit
Power Output	34.997	3.16	60
	Frequency	dBc	Margin
	53.930	72.3	14.3
	80.895	65.4	5.4
	107.860	62.3	2.3
	134.825	62.5	2.5
	161.790	64.0	4.0
	188.755	65.0	5.0
	215.720	67.9	7.9
	242.685	68.2	8.2
	269.650	69.1	9.1

Test Data: Middle Of Band Ch 20 – 27.205 MHz

Modulated	dBm	Watts	Limit
Power Output	34.997	3.16	60
	Frequency	dBc	Margin
	27.20	0	0.0
	54.40	69.0	9.0
	81.60	64.4	4.4
	108.80	62.4	2.4
	136.00	61.6	1.6
	163.20	63.6	3.6
	190.40	64.7	4.7
	217.60	67.3	7.3
	244.80	68.5	8.5
	272.00	69.1	9.1

[Table Of Contents](#)

APPLICANT: PRESIDENT ELECTRONICS USA
 FCC ID: 2AEOCUT411
 IC: 20240-UT411
 REPORT # : 2245ZAUT15TestReport_Rev1



SPURIOUS EMISSIONS AT ANTENNA TERMINALS (CONDUCTED)

Test Data: High End of Band Ch 40 – 27.405 MHz

Modulated	dBm	Watts	Limit
Power Output	34.857	3.06	60
	Frequency	dBc	Margin
	27.40	0	0.0
	54.80	69.2	9.2
	82.20	64.7	4.7
	109.60	62.0	2.0
	137.00	61.4	1.4
	164.40	65.3	5.3
	191.80	65.9	5.9
	219.20	67.2	7.2
	246.60	71.3	11.3
	274.00	73.6	13.6

Results meet requirements

[Table Of Contents](#)

APPLICANT: PRESIDENT ELECTRONICS USA
FCC ID: 2AEOCUT411
IC: 20240-UT411
REPORT # : 2245ZAUT15TestReport_Rev1

FIELD STRENGTH OF SPURIOUS EMISSIONS

FCC Rule Part No: 2.1053(a)(b), 95.635(b)(8)(9)

IC RSS: 236 § 5.4.4, GEN § 6.13

Limit: The power of each unwanted emission shall be less than Transmitter Power at least $53 + 10 \log_{10}(T)$ dB on any frequency removed from the center of the authorized bandwidth by more than 250%.

In addition the power of each unwanted emission shall be less than Transmitter Power at least 60 dB on any frequency twice or greater than twice the fundamental frequency.

Procedure: TIA 603-D § 2.2.12 Transmitter Radiated Spurious
 ANSI C63.4-2009 § 8.1 General Measurement Requirements
 ANSI C63.4-2009 § 8.2 Antenna selection, placement, and distance
 ANSI C63.4-2009 § 8.3 Radiated emission procedures
 IC RSS 236 § 5.4.1 Single-Sideband Transmitters
 IC RSS 236 § 5.4.3 Minimum Standards

Setup:

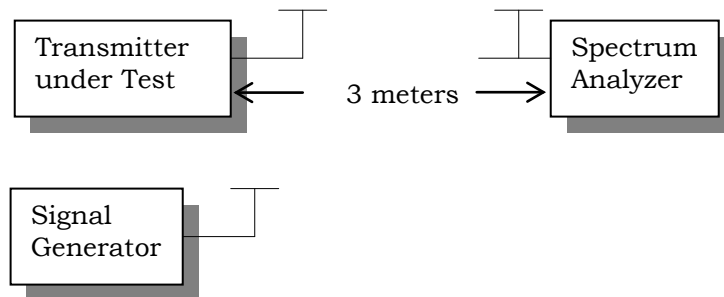

[Table Of Contents](#)



FIELD STRENGTH OF SPURIOUS EMISSIONS

Notes: The following tabulated data shows the results of the radiated field strength emissions test. The spectrum was scanned from 30 MHz to at least the tenth harmonic of the fundamental.

Test Data: Low End of Band

Emission Frequency (MHz)	Power Mode	ERP Power Output (dBm)	ERP Power Output (Watts)	FCC Requirement dB	Bandwidth - BW - kHz
27.02	Hi	34.99	3.16	60	8.0
Emission Frequency (MHz)	Ant. Polarity	Below Carrier (dBc)	Margin		
52.49	V	106.26	46.26		
54.05	V	92.84	32.84		
59.90	H	102.47	42.47		
67.50	V	104.35	44.35		
73.74	V	96.37	36.37		
81.24	V	100.47	40.47		
107.84	H	106.49	46.49		
109.99	V	99.76	39.76		
130.00	H	104.01	44.01		
135.13	V	105.30	45.3		
188.75	H	99.67	39.67		
188.76	V	95.75	35.75		
215.46	H	100.07	40.07		
216.20	V	100.36	40.36		
243.23	V	101.28	41.28		
270.25	V	103.67	45.3		

RESULTS MEET REQUIREMENTS

[Table Of Contents](#)

APPLICANT: PRESIDENT ELECTRONICS USA
 FCC ID: 2AEOCUT411
 IC: 20240-UT411
 REPORT #: 2245ZAUT15TestReport_Rev1



FIELD STRENGTH OF SPURIOUS EMISSIONS

Test Data: Middle of Band

Emission Frequency (MHz)	Power Mode	ERP Power Output (dBm)	ERP Power Output (Watts)	FCC Requirement dB	Bandwidth - BW - kHz
27.20	Hi	34.99	3.16	60	8.0
Emission Frequency (MHz)	Ant. Polarity	Below Carrier (dBc)		Margin	
54.40	V	93.50		33.5	
59.99	H	103.17		43.17	
81.60	V	112.61		52.61	
108.80	V	99.12		39.12	
136.00	V	106.64		46.64	
163.20	V	106.81		46.81	
217.60	H	100.48		40.48	
239.66	H	105.09		45.09	
244.80	H	101.84		41.84	
272.00	H	100.45		40.45	

Test Data: High End of Band

Emission Frequency (MHz)	Power Mode	ERP Power Output (dBm)	ERP Power Output (Watts)	FCC Requirement dB	Bandwidth - BW - kHz
27.40	Hi	34.85	3.05	60	8.0
Emission Frequency (MHz)	Ant. Polarity	Below Carrier (dBc)		Margin	
54.80	H	100.79		40.79	
54.80	V	92.85		32.85	
68.72	V	102.97		42.97	
73.76	V	96.64		36.64	
82.20	H	116.43		56.43	
103.76	H	90.03		30.03	
109.60	V	99.62		39.62	
109.61	V	99.13		39.13	
137.00	V	108.09		48.09	
191.80	H	99.01		39.01	
219.20	H	101.21		41.21	
239.82	H	100.38		40.38	
246.60	H	102.16		42.16	
274.00	H	103.81		43.81	

RESULTS MEET REQUIREMENTS

[Table Of Contents](#)

APPLICANT: PRESIDENT ELECTRONICS USA
 FCC ID: 2AEOCUT411
 IC: 20240-UT411
 REPORT #: 2245ZAUT15TestReport_Rev1

FREQUENCY STABILITY

FCC Rule Part No: 2.1055, 95.625 (b)

IC RSS: GEN § 6.11

Limit: Each CB transmitter must be maintained within a frequency tolerance of 0.005%

Procedure: TIA 603-D § 2.2.19 Transmitter Carrier Frequency Tolerance
ANSI C63.10-2013 § 6.8 Frequency stability tests
IC RSS GEN § 6.11 Transmitter Frequency Stability

Setup:

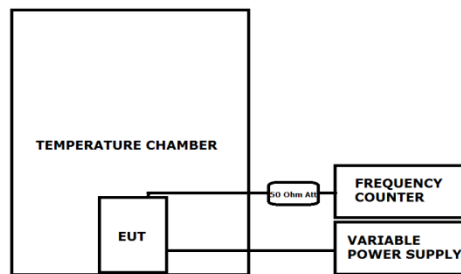

Test Data: 13.8 VDC Nominal Voltage Measurement Table

Assigned Frequency (Ref. Frequency) (MHz)		26.964993
Temperature (°C)	Frequency (MHz)	Frequency Stability (PPM)
-30	26.965158	-0.000165
-20	26.965095	-0.000102
-10	26.965079	-0.000086
0	26.965132	-0.000139
+10	26.965069	-0.000076
+20	26.965021	-0.000028
+30	26.964992	0.000001
+40	26.964984	0.000009
+50	26.965006	-0.000013
Assigned Frequency (Ref. Frequency) (MHz)		26.964993
Battery %	Frequency (MHz)	Frequency Stability (PPM)
-15%	26.9649927	-0.01
0	26.9649917	-0.05
+15%	26.9649907	-0.09

Results Meet Requirements

[Table Of Contents](#)

APPLICANT: PRESIDENT ELECTRONICS USA
 FCC ID: 2AEOCUT411
 IC: 20240-UT411
 REPORT #: 2245ZAUT15TestReport_Rev1



EQUIPMENT LIST

Device	Manufacturer	Model	Serial Number	Cal/ Char Date	Due Date
12 Volt Power Supply	Astron 50Amp.	VS-50M	9001191	N/A	N/A
Antenna: Biconnical Chamber	Eaton Chamber	94455-1	1096	07/14/15	07/14/17
Antenna: Log-Periodic Chamber	Eaton	LPA-25	1122	07/14/15	07/14/17
Temperature Chamber LARGE	Tenney Engineering	TTRC	11717-7	08/19/14	08/19/16
Digital Multimeter	Fluke	77	35053830	10/21/15	10/21/17
Modulation Analyzer	HP	8901A	3050A05856	4/16/2015	4/16/2017
DC Power Supply	HP	6286A	2411A09414	12/12/99	12/12/99
Frequency Counter Large Chamber	HP	5352B	2632A00165	07/01/15	07/01/17
3-Meter Semi-Anechoic Chamber	Panashield	N/A	N/A	12/31/13	12/31/15
Antenna: Double-Ridged Horn/ETS Horn 1	ETS-Lindgren	3117	00035923	06/13/14	06/13/16
EMI Test Receiver R & S ESU 40 Chamber	Rohde & Schwarz	ESU 40	100320	03/11/14	03/11/16
EMI Test Receiver R & S ESIB 40 Screen Room	Rohde & Schwarz	ESIB 40	100274	08/12/14	08/12/16
Software: Field Strength Program	Timco	N/A	Version 4.0	N/A	N/A
Hygro-Thermometer	Extech	445703	0602	06/30/15	06/30/17
Signal Generator R & S SMIQ 02	Rohde & Schwarz	SMIQ02	DE24678	06/11/14	06/11/16
LISN (Secondary/Auxiliary)	Electro-Metrics	EM-7821	101	10/29/15	10/29/17
Attenuator BNC 10dB	Elcom Systems	AT-51-10	# 39	6/24/2015	06/24/17
Notch Filter	Eagle	TNF-200	---	N/A	N/A
Attenuator N 30dB 10W DC-18G	Pasternack	PE7015-30	# 24	6/22/2015	06/22/17
Signal Generator	HP	8640B	2717A29175	7/13/2015	7/13/2017

* EMI RECEIVER SOFTWARE VERSION

The receiver firmware used was version 4.43 Service Pack 3

[Table Of Contents](#)

APPLICANT: PRESIDENT ELECTRONICS USA
 FCC ID: 2AEOCUT411
 IC: 20240-UT411
 REPORT #: 2245ZAUT15TestReport_Rev1