

## SAR EVALUATION REPORT

For

### MAXWEST INTERNATIONAL LIMITED

No.1, Longgang Road, Buji, Longgang, ShenzhenCity, Guangdong Province, P.R. China

**FCC ID: 2AEN3GRAVITY55LTE**

<b>Report Type:</b> Original Report	<b>Product Type:</b> Mobile Phone
<b>Test Engineer:</b> Rocky Xiao	<i>Rocky Xiao</i>
<b>Report Number:</b> RDG150901001-20B	
<b>Report Date:</b> 2015-09-24	
<b>Reviewed By:</b> RF Leader	Sula Huang <i>Sula Huang</i>
<b>Test Laboratory:</b>	Bay Area Compliance Laboratories Corp. (Dongguan) No.69 Pulongcun, Puxinhu Industrial Zone, Tangxia, Dongguan, Guangdong, China Tel: +86-769-86858888 Fax: +86-769-86858891 <a href="http://www.baclcorp.com.cn">www.baclcorp.com.cn</a>

Attestation of Test Results		
<b>EUT Information</b>	<b>Company Name</b>	MAXWEST INTERNATIONAL LIMITED
	<b>EUT Description</b>	Mobile Phone
	<b>Product Name</b>	Gravity 5.5LTE
	<b>FCC ID</b>	2AEN3GRAVITY55LTE
	<b>Model Number</b>	Gravity 5.5LTE
	<b>Serial Number</b>	150901001
	<b>Test Date</b>	2015-09-07,2015-09-08,2015-09-09
<b>MODE</b>		<b>Max. SAR Level(s) Reported(W/Kg)</b>
<b>GSM 850</b>	1g Head SAR	0.061
	1g Body SAR	0.479
<b>PCS 1900</b>	1g Head SAR	0.147
	1g Body SAR	1.25
<b>WCDMA Band 5</b>	1g Head SAR	0.049
	1g Body SAR	0.301
<b>WCDMA Band 4</b>	1g Head SAR	0.372
	1g Body SAR	1.305
<b>WCDMA Band 2</b>	1g Head SAR	0.249
	1g Body SAR	1.263
<b>LTE Band 2</b>	1g Head SAR	0.122
	1g Body SAR	1.205
<b>LTE Band 4</b>	1g Head SAR	0.101
	1g Body SAR	0.955
<b>LTE Band 7</b>	1g Head SAR	0.174
	1g Body SAR	1.043
<b>LTE Band 17</b>	1g Head SAR	0.057
	1g Body SAR	0.374
<b>Simultaneous</b>	1g Head SAR	0.736
	1g Body SAR	1.431
<b>Hotspot</b>	1g Body SAR	1.431
<b>Applicable Standards</b>	<b>ANSI / IEEE C95.1 : 2005</b> IEEE Standard for Safety Levels with Respect to Human Exposure to Radio Frequency Electromagnetic Fields,3 kHz to 300 GHz.	
	<b>ANSI / IEEE C95.3 : 2002</b> IEEE Recommended Practice for Measurements and Computations of Radio Frequency Electromagnetic Fields With Respect to Human Exposure to Such Fields,100 kHz—300 GHz.	
	<b>FCC 47 CFR part 2.1093</b> Radiofrequency radiation exposure evaluation: portable devices	
	<b>IEEE1528:2013</b> IEEE Recommended Practice for Determining the Peak Spatial-Average Specific Absorption Rate (SAR) in the Human Head from Wireless Communications Devices: Measurement Techniques	
	<b>IEC 62209-2:2010</b> Human exposure to radio frequency fields from hand-held and body-mounted wireless communication devices-Human models, instrumentation, and procedures-Part 2: Procedure to determine the specific absorption rate (SAR) for wireless communication devices used in close proximity to the human body (frequency range of 30 MHz to 6 GHz)	
	<b>KDB procedures</b> KDB 447498 D01 General RF Exposure Guidance v05r02. KDB 648474 D04 Handset SAR v01r02. KDB 865664 D01 SAR measurement 100 MHz to 6 GHz v01r03 KDB 865664 D02 RF Exposure Reporting v01r01 KDB 941225 D01 3G SAR Procedures v03 KDB 941225 D05 SAR for LTE Devices v02r03 KDB 941225 D06 Hotspot Mode v02	

1.6

**Note:** This wireless device has been shown to be capable of compliance for localized specific absorption rate (SAR) for General Population/Uncontrolled Exposure limits specified in ANSI/IEEE Standards and has been tested in accordance with the measurement procedures specified in IEEE 1528-2013 and RF exposure KDB procedures.  
**The results and statements contained in this report pertain only to the device(s) evaluated.**

Note: For LTE band 17 SAR, please refer to the SAR report: RDG150901001-20A, which was issued by Bay Area Compliance Laboratories Corp. (Shenzhen)

F I N A L

## TABLE OF CONTENTS

<b>DOCUMENT REVISION HISTORY .....</b>	<b>6</b>
<b>EUT DESCRIPTION .....</b>	<b>7</b>
TECHNICAL SPECIFICATION .....	7
<b>REFERENCE, STANDARDS, AND GUIDELINES .....</b>	<b>8</b>
SAR LIMITS .....	9
<b>FACILITIES .....</b>	<b>10</b>
<b>DESCRIPTION OF TEST SYSTEM .....</b>	<b>11</b>
<b>EQUIPMENT LIST AND CALIBRATION .....</b>	<b>17</b>
EQUIPMENTS LIST & CALIBRATION INFORMATION .....	17
<b>SAR MEASUREMENT SYSTEM VERIFICATION .....</b>	<b>18</b>
LIQUID VERIFICATION .....	18
SYSTEM ACCURACY VERIFICATION .....	28
SAR SYSTEM VALIDATION DATA .....	29
<b>EUT TEST STRATEGY AND METHODOLOGY .....</b>	<b>37</b>
TEST POSITIONS FOR DEVICE OPERATING NEXT TO A PERSON’S EAR.....	37
CHEEK/TOUCH POSITION .....	38
EAR/TILT POSITION .....	38
TEST POSITIONS FOR BODY-WORN AND OTHER CONFIGURATIONS .....	39
SAR EVALUATION PROCEDURE.....	40
TEST METHODOLOGY .....	40
<b>CONDUCTED OUTPUT POWER MEASUREMENT .....</b>	<b>41</b>
PROVISION APPLICABLE .....	41
TEST PROCEDURE .....	41
RADIO CONFIGURATION .....	41
MAXIMUM TARGET OUTPUT POWER .....	47
TEST RESULTS: .....	48
<b>SAR MEASUREMENT RESULTS .....</b>	<b>59</b>
SAR TEST DATA.....	59
<b>SAR SIMULTANEOUS TRANSMISSION DESCRIPTION .....</b>	<b>69</b>
<b>SAR SIMULTANEOUS TRANSMISSION DESCRIPTION .....</b>	<b>69</b>
<b>SAR PLOTS (SUMMARY OF THE HIGHEST SAR VALUES).....</b>	<b>75</b>
<b>APPENDIX A MEASUREMENT UNCERTAINTY .....</b>	<b>91</b>
<b>APPENDIX B – PROBE CALIBRATION CERTIFICATES.....</b>	<b>93</b>
<b>APPENDIX C DIPOLE CALIBRATION CERTIFICATES .....</b>	<b>104</b>
<b>APPENDIX D EUT TEST POSITION PHOTOS .....</b>	<b>128</b>
LIQUID DEPTH ≥ 15CM.....	128
LEFT HEAD CHEEK .....	128
LEFT HEAD TILT .....	129
RIGHT HEAD CHEEK .....	129
RIGHT HEAD TILT .....	130
BODY -WORN-BACK (10MM).....	130
BODY -HEADSET-BACK (10MM) .....	131
BODY -WORN-LEFT (10MM).....	131
BODY -WORN-RIGHT (10MM).....	132
BODY -WORN-BOTTOM(10MM).....	132

---

<b>APPENDIX E EUT PHOTOS .....</b>	<b>133</b>
EUT – FRONT VIEW .....	133
EUT – BACK VIEW .....	133
EUT – SIDE VIEW-1 .....	134
EUT – SIDE VIEW-2 .....	134
EUT – UNCOVER VIEW .....	135

F I N A L

**DOCUMENT REVISION HISTORY**

Revision Number	Report Number	Description of Revision	Date of Revision
0	RDG150901001-20B	Original Report	2015-09-24

Note: For LTE band 17 SAR, please refer to the SAR report: RDG150901001-20A, which was issued by Bay Area Compliance Laboratories Corp. (Shenzhen)

FINAL

### EUT DESCRIPTION

This report has been prepared on behalf of MAXWEST INTERNATIONAL LIMITED and their product *Mobile Phone(named Gravity 5.5LTE by applicant )*, Model: Gravity 5.5LTE, FCC ID: 2AEN3GRAVITY55LTE or the EUT (Equipment under Test) as referred to in the rest of this report.

### Technical Specification

<b>Exposure Category:</b>	Population / Uncontrolled
<b>Antenna Type(s):</b>	Internal Antenna
<b>Body-Worn Accessories:</b>	Portable
<b>Face-Head Accessories:</b>	Headset
<b>Operation Mode :</b>	GSM Voice, GPRS/EGPRS class 12, WCDMA R99 (Voice+Data),HSUPA Rel 6,HSDPA Rel 7, DC-HSDPA Rel 8, HSPA+ Rel 6 FDD-LTE WLAN Bluetooth
<b>Frequency Band:</b>	GSM 850 : 824-849 MHz(TX) ; 869-894 MHz(RX) PCS 1900: 1850-1910 MHz(TX) ; 1930-1990 MHz(RX) WCDMA Band 5: 824-849 MHz(TX) ; 869-894 MHz(RX) WCDMA Band 4: 1710-1755 MHz(TX) ; 2110-2155 MHz(RX) WCDMA Band 2: 1850-1910 MHz(TX) ; 1930-1990 MHz(RX) LTE Band 2: 1850-1910 MHz(TX) ; 1930-1990 MHz(RX) LTE Band 4: 1710-1755 MHz(TX) ; 2110-2155 MHz(RX) LTE Band 7: 2500-2570 MHz(TX) ; 2620-2690 MHz(RX) LTE Band 17: 704-716 MHz(TX) ; 734-746 MHz(RX) WLAN: 2412MHz-2462 MHz Bluetooth : 2402MHz-2480 MHz
<b>Conducted RF Power:</b>	GSM 850 : 32.97 dBm PCS 1900: 29.55 dBm WCDMA Band 5: 22.32 dBm WCDMA Band 4: 22.84 dBm WCDMA Band 2: 22.39 dBm LTE Band 2:23.15 dBm LTE Band 4:22.81 dBm LTE Band 7:22.98 dBm LTE Band 17:22.86 dBm WLAN: 9.37 dBm Bluetooth: 3.02 dBm BLE:-3.28 dBm
<b>Dimensions (L*W*H):</b>	156 mm (L) × 78.3 mm (W) × 7.8 mm (H)
<b>Power Source:</b>	3.7 VDC Rechargeable Battery
<b>Normal Operation:</b>	Head and Body-worn

## REFERENCE, STANDARDS, AND GUIDELINES

---

### **FCC:**

The Report and Order requires routine SAR evaluation prior to equipment authorization of portable transmitter devices, including portable telephones. For consumer products, the applicable limit is 1.6 mW/g as recommended by the ANSI/IEEE standard C95.1-1992 [6] for an uncontrolled environment (Paragraph 65). According to the Supplement C of OET Bulletin 65 "Evaluating Compliance with FCC Guide-lines for Human Exposure to Radio frequency Electromagnetic Fields", released on Jun 29, 2001 by the FCC, the device should be evaluated at maximum output power (radiated from the antenna) under "worst-case" conditions for normal or intended use, incorporating normal antenna operating positions, device peak performance frequencies and positions for maximum RF energy coupling.

This report describes the methodology and results of experiments performed on wireless data terminal. The objective was to determine if there is RF radiation and if radiation is found, what is the extent of radiation with respect to safety limits. SAR (Specific Absorption Rate) is the measure of RF exposure determined by the amount of RF energy absorbed by human body (or its parts) – to determine how the RF energy couples to the body or head which is a primary health concern for body worn devices. The limit below which the exposure to RF is considered safe by regulatory bodies in North America is 1.6 mW/g average over 1 gram of tissue mass.

### **CE:**

The order requires routine SAR evaluation prior to equipment authorization of portable transmitter devices, including portable telephones. For consumer products, the applicable limit is 2 mW/g as recommended by EN62209-1 for an uncontrolled environment. According to the Standard, the device should be evaluated at maximum output power (radiated from the antenna) under "worst-case" conditions for normal or intended use, incorporating normal antenna operating positions, device peak performance frequencies and positions for maximum RF energy coupling.

This report describes the methodology and results of experiments performed on wireless data terminal. The objective was to determine if there is RF radiation and if radiation is found, what is the extent of radiation with respect to safety limits. SAR (Specific Absorption Rate) is the measure of RF exposure determined by the amount of RF energy absorbed by human body (or its parts) – to determine how the RF energy couples to the body or head which is a primary health concern for body worn devices. The limit below which the exposure to RF is considered safe by regulatory bodies in Europe is 2 mW/g average over 10 gram of tissue mass.

The test configurations were laid out on a specially designed test fixture to ensure the reproducibility of measurements. Each configuration was scanned for SAR. Analysis of each scan was carried out to characterize the above effects in the device.



**SAR Limits**

**FCC Limit (1g Tissue)**

EXPOSURE LIMITS	SAR (W/kg)	
	(General Population / Uncontrolled Exposure Environment)	(Occupational / Controlled Exposure Environment)
Spatial Average (averaged over the whole body)	0.08	0.4
Spatial Peak (averaged over any 1 g of tissue)	1.60	8.0
Spatial Peak (hands/wrists/feet/ankles averaged over 10 g)	4.0	20.0

**CE Limit (10g Tissue)**

EXPOSURE LIMITS	SAR (W/kg)	
	(General Population / Uncontrolled Exposure Environment)	(Occupational / Controlled Exposure Environment)
Spatial Average (averaged over the whole body)	0.08	0.4
Spatial Peak (averaged over any 10 g of tissue)	2.0	10
Spatial Peak (hands/wrists/feet/ankles averaged over 10 g)	4.0	20.0

Population/Uncontrolled Environments are defined as locations where there is the exposure of individual who have no knowledge or control of their exposure.

Occupational/Controlled Environments are defined as locations where there is exposure that may be incurred by people who are aware of the potential for exposure (i.e. as a result of employment or occupation).

General Population/Uncontrolled environments Spatial Peak limit 1.6W/kg (FCC) & 2 W/kg (CE) applied to the EUT.

---

## **FACILITIES**

---

The Test site used by Bay Area Compliance Laboratories Corp. (Dongguan) to collect test data is located on the No.69 Pulongcun, Puxinhu Industrial Zone, Tangxia, Dongguan, Guangdong, China

F I N A L

## DESCRIPTION OF TEST SYSTEM

These measurements were performed with the automated near-field scanning system DASY5 from Schmid & Partner Engineering AG (SPEAG) which is the Fifth generation of the system shown in the figure hereinafter:



### DASY5 System Description

The DASY5 system for performing compliance tests consists of the following items:

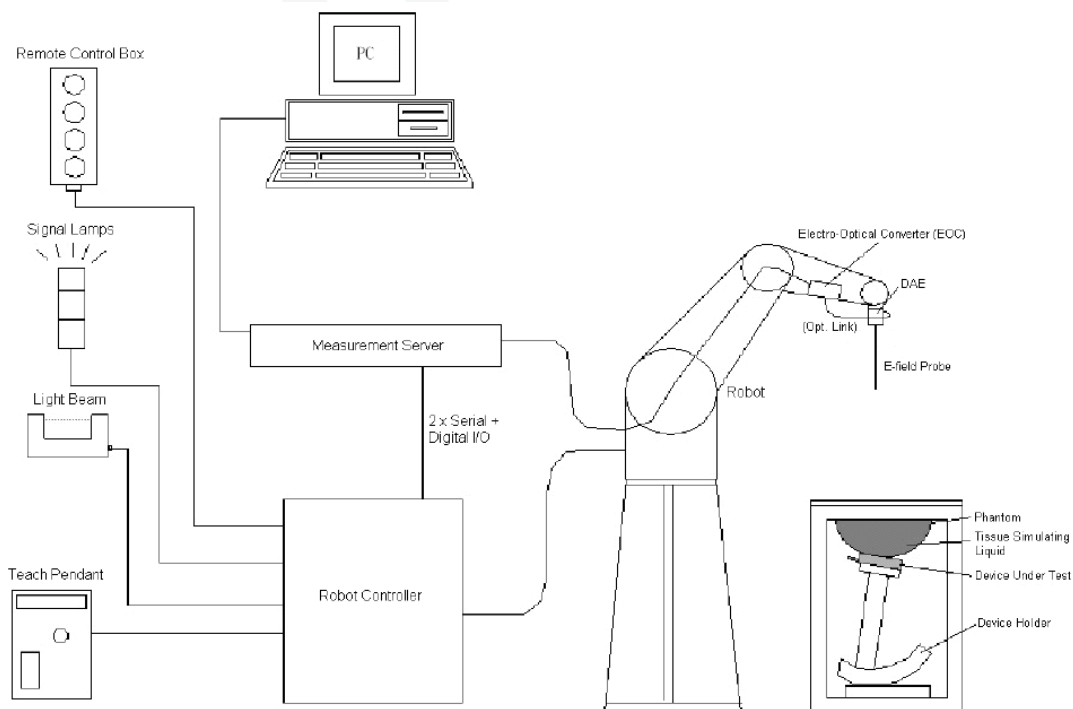

- A standard high precision 6-axis robot (Staubli TX=RX family) with controller, teach pendant and software. An arm extension for accommodating the data acquisition electronics (DAE).
- An isotropic field probe optimized and calibrated for the targeted measurement.
- A data acquisition electronics (DAE) which performs the signal application, signal multiplexing, AD-conversion, offset measurements, mechanical surface detection, collision detection, etc. The unit is battery powered with standard or rechargeable batteries. The signal is optically transmitted to the EOC.
- The Electro-optical converter (EOC) performs the conversion from optical to electrical signals for the digital communication to the DAE. To use optical surface detection, a special version of the EOC is required. The EOC signal is transmitted to the measurement server.
- The function of the measurement server is to perform the time critical tasks such as signal filtering, control of the robot operation and fast movement interrupts.
- The Light Beam used is for probe alignment. This improves the (absolute) accuracy of the probe positioning.
- A computer running Win7 professional operating system and the DASY52 software.
- Remote control and teach pendant as well as additional circuitry for robot safety such as warning lamps, etc.
- The phantom, the device holder and other accessories according to the targeted measurement.

#### **DASY5 Measurement Server**

The DASY5 measurement server is based on a PC/104 CPU board with a 400MHz intel ULV Celeron, 128MB chip-disk and 128MB RAM. The necessary circuits for communication with the DAE4 (or DAE3) electronics box, as well as the 16 bit AD converter system for optical detection and digital I/O interface are contained on the DASY5 I/O board, which is directly connected to the PC/104 bus of the CPU board.



The measurement server performs all real-time data evaluation of field measurements and surface detection, controls robot movements and handles safety operation. The PC operating system cannot interfere with these time critical processes. All connections are supervised by a watchdog, and disconnection of any of the cables to the measurement server will automatically disarm the robot and disable all program-controlled robot movements. Furthermore, the measurement server is equipped with an expansion port which is reserved for future applications. Please note that this expansion port does not have a standardized point out, and therefore only devices provided by SPEAG can be connected. Devices from any other supplier could seriously damage the measurement server.

#### **Data Acquisition Electronics**

The data acquisition electronics (DAE4) consist of a highly sensitive electrometer-grade preamplifier with auto-zeroing, a channel and gain-switching multiplexer, a fast 16 bit AD-converter and a command decoder with a control logic unit. Transmission to the measurement server is accomplished through an optical downlink for data and status information, as well as an optical uplink for commands and the clock.

The mechanical probe mounting device includes two different sensor systems for frontal and sideways probe contacts. They are used for mechanical surface detection and probe collision detection.

The input impedance of both the DAE4 as well as of the DAE3 box is 200MOhm; the inputs are symmetrical and floating. Common mode rejection is above 80 dB.

**EX3DV4 E-Field Probes**

<b>Frequency</b>	10 MHz to > 6 GHz Linearity: ± 0.2 dB (30 MHz to 6 GHz)
<b>Directivity</b>	± 0.3 dB in TSL (rotation around probe axis) ± 0.5 dB in TSL (rotation normal to probe axis)
<b>Dynamic Range</b>	10 µW/g to > 100 mW/g Linearity: ± 0.2 dB (noise: typically < 1 µW/g)
<b>Dimensions</b>	Overall length: 337 mm (Tip: 20 mm) Tip diameter: 2.5 mm (Body: 12 mm) Typical distance from probe tip to dipole centers: 1 mm
<b>Application</b>	High precision dosimetric measurements in any exposure scenario (e.g., very strong gradient fields); the only probe that enables compliance testing for frequencies up to 6 GHz with precision of better 30%.
<b>Compatibility</b>	DASY3, DASY4, DASY52 SAR and higher, EASY4/MRI

**SAM Twin Phantom**

The SAM twin phantom is a fiberglass shell phantom with 2mm shell thickness (except the ear region, where shell thickness increases to 6 mm). The phantom has three measurement areas:

- \_ Left hand
- \_ Right hand
- \_ Flat phantom

The phantom table for the DASY systems based on the TX90XL and RX160L robots have the size of 100 x 50 x 85 cm (L x Wx H). The phantom table for the compact DASY systems based on the RX60L robot have the size of 100 x 75 x 91 cm (L x Wx H); these tables are reinforced for mounting of the robot onto the table.

For easy dislocation these tables have fork lift cut outs at the bottom.

The bottom plate contains three pairs of bolts for locking the device holder. The device holder positions are adjusted to the standard measurement positions in the three sections. Only one device holder is necessary if two phantoms are used (e.g., for different liquids)



A white cover is provided to cover the phantom during off-periods to prevent water evaporation and changes in the liquid parameters. Free space scans of devices on top of this phantom cover are possible. Three reference marks are provided on the phantom counter. These reference marks are used to teach the absolute phantom position relative to the robot.

### **Device Holder for SAM Twin Phantom**

The SAR in the phantom is approximately inversely proportional to the square of the distance between the source and the liquid surface. For a source in 5mm distance, a positioning uncertainty of  $\pm 0.5$  mm would produce a SAR uncertainty of  $\pm 20\%$ . An accurate device positioning is therefore crucial for accurate and repeatable measurements. The positions, in which the devices must be measured, are defined by the standards.

The DASY device holder is designed to cope with different positions given in the standard. It has two scales for the device rotation (with respect to the body axis) and the device inclination (with respect to the line between the ear reference points). The rotation centers for both scales are the ear reference point ERP). Thus the device needs no repositioning when changing the angles.



The DASY device holder has been made out of low-loss POM material having the following dielectric parameters: relative permittivity  $\epsilon_r=3$  and loss tangent  $\tan \delta=0.02$ . The amount of dielectric material has been reduced in the closest vicinity of the device, since measurements have suggested that the influence of the clamp on the test results could thus be lowered.

### **Robots**

The DASY5 system uses the high precision industrial robots TX90XL from Staubli SA (France). The TX robot family is the successor of the well known RX robot family and offers the same features important for our application:

- High precision (repeatability 0.02mm)
- High reliability (industrial design)
- Low maintenance costs (virtually maintenance free due to direct drive gears; no belt drives)
- Jerk-free straight movements (brushless synchrony motors; no stepper motors)
- Low ELF interference (motor control fields shielded via the closed metallic construction shields)

The above mentioned robots are controlled by the Staubli CS8c robot controllers. All information regarding the use and maintenance of the robot arm and the robot controller is contained on the CDs delivered along with the robot. Paper manuals are available upon request direct from Staubli.

### **Area Scans**

Area scans are defined prior to the measurement process being executed with a user defined variable spacing between each measurement point (integral) allowing low uncertainty measurements to be conducted. Scans defined for FCC applications utilize a 10mm<sup>2</sup> step integral, with 1mm interpolation used to locate the peak SAR area used for zoom scan assessments.

Where the system identifies multiple SAR peaks (which are within 25% of peak value) the system will provide the user with the option of assessing each peak location individually for zoom scan averaging.

### **Zoom Scan (Cube Scan Averaging)**

The averaging zoom scan volume utilized in the DASY5 software is in the shape of a cube and the side dimension of a 1 g or 10 g mass is dependent on the density of the liquid representing the simulated tissue. A density of 1000 kg/m<sup>3</sup> is used to represent the head and body tissue density and not the phantom liquid density, in order to be consistent with the definition of the liquid dielectric properties, i.e. the side length of the 1 g cube is 10mm, with the side length of the 10 g cube 21,5mm.

When the cube intersects with the surface of the phantom, it is oriented so that 3 vertices touch the surface of the shell or the center of a face is tangent to the surface. The face of the cube closest to the surface is modified in order to conform to the tangent surface.

The zoom scan integer steps can be user defined so as to reduce uncertainty, but normal practice for typical test applications (including FCC) utilize a physical step of 5x5x8 (8mmx8mmx5mm) providing a volume of 32mm in the X & Y axis, and 35mm in the Z axis.

**Recommended Tissue Dielectric Parameters for Head and Body**

Frequency (MHz)	Head Tissue		Body Tissue	
	$\epsilon_r$	$\sigma$ (S/m)	$\epsilon_r$	$\sigma$ (S/m)
150	52.3	0.76	61.9	0.80
300	45.3	0.87	58.2	0.92
450	43.5	0.87	56.7	0.94
835	41.5	0.90	55.2	0.97
900	41.5	0.97	55.0	1.05
915	41.5	0.98	55.0	1.06
1450	40.5	1.20	54.0	1.30
1610	40.3	1.29	53.8	1.40
1800-2000	40.0	1.40	53.3	1.52
2450	39.2	1.80	52.7	1.95
3000	38.5	2.40	52.0	2.73
5800	35.3	5.27	48.2	6.00



## EQUIPMENT LIST AND CALIBRATION

### Equipments List & Calibration Information

Equipment	Model	S/N	Calibration Date	Calibration Due Date
Robot	RX90	D03636	N/A	N/A
DASY5 Test Software	DASY52.8	N/A	N/A	N/A
DASY5 Measurement Server	DASY5 4.5.12	1470	N/A	N/A
Data Acquisition Electronics	DAE4	1459	2015-01-26	2016-01-26
E-Field Probe	EX3DV4	7329	2015-02-05	2016-02-05
Dipole, 835MHz	D835V1	453	2015-08-17	2018-08-17
Dipole, 1750MHz	D1750V2	1141	2015-07-09	2018-07-09
Dipole, 1900MHz	D1900V2	5d206	2015-07-14	2018-07-14
Dipole, 2450MHz	D2450V3	971	2015-07-08	2018-07-08
R&S, universal Radio Communication Tester	CMU200	105047	2014-11-20	2015-11-20
Wideband Radio Communication Tester	CMW500	1201.0002K50-146520-wh	2014-11-19	2015-11-19
Mounting Device	MD4HHTV5	SD 000 H01 KA	N/A	N/A
Twin SAM	Twin SAM V5.0	1874	N/A	N/A
Simulated Tissue 835 MHz Head	TS-835-H	201504	Each Time	/
Simulated Tissue 835 MHz Body	TS-835-B	201505	Each Time	/
Simulated Tissue 1750 MHz Head	TS-1750-H	201508	Each Time	/
Simulated Tissue 1750 MHz Body	TS-1750-B	201509	Each Time	/
Simulated Tissue 1900 MHz Head	TS-1900-H	201506	Each Time	/
Simulated Tissue 1900 MHz Body	TS-1900-B	201507	Each Time	/
Simulated Tissue 2450 MHz Head	TS-2450-H	201512	Each Time	/
Simulated Tissue 2450 MHz Body	TS-2450-B	201513	Each Time	/
Network Analyzer	8752C	3140A02356	2015-06-03	2016-06-03
Dielectric probe kit	85070B	US33020324	2015-06-13	2016-06-13
Signal Generator	E4422B	MY41000355	2014-10-27	2015-10-27
Power Meter	EPM-441A	GB37481494	2014-11-03	2015-11-03
Power Meter Sensor	8481A	T-03-EM-127	2014-11-03	2015-11-03
Power Amplifier	5205PE	1015	N/A	N/A
Directional Coupler	488Z	N/A	N/A	N/A
attenuator	20dB, 100W	N/A	N/A	N/A

## SAR MEASUREMENT SYSTEM VERIFICATION

### Liquid Verification

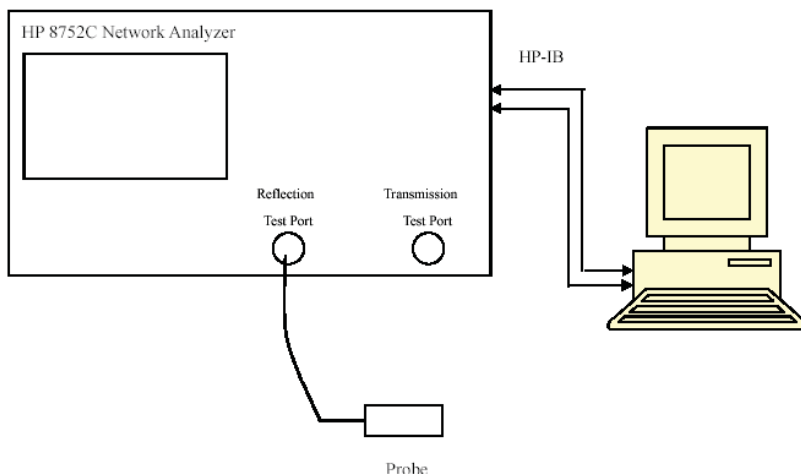

Liquid Verification Setup Block Diagram

### Liquid Verification Results

Frequency	Liquid Type	Liquid Parameter		Target Value		Delta (%)		Tolerance (%)
		$\epsilon_r$	$\sigma$ (S/m)	$\epsilon_r$	$\sigma$ (S/m)	$\Delta\epsilon_r$	$\Delta\sigma$ (S/m)	
824.2	Head	42.923	0.878	41.5	0.9	3.43	-2.44	$\pm 5$
	Body	55.138	0.963	55.2	0.97	-0.11	-0.72	$\pm 5$
826.4	Head	42.874	0.879	41.5	0.9	3.31	-2.33	$\pm 5$
	Body	55.135	0.966	55.2	0.97	-0.12	-0.41	$\pm 5$
836.6	Head	42.87	0.893	41.5	0.9	3.3	-0.78	$\pm 5$
	Body	55.108	0.976	55.2	0.97	-0.17	0.62	$\pm 5$
846.6	Head	42.803	0.895	41.5	0.9	3.14	-0.56	$\pm 5$
	Body	55.034	0.985	55.2	0.97	-0.3	1.55	$\pm 5$
848.8	Head	42.701	0.896	41.5	0.9	2.89	-0.44	$\pm 5$
	Body	54.994	0.987	55.2	0.97	-0.37	1.75	$\pm 5$

\*Liquid Verification above was performed on 2015-09-07.

Frequency	Liquid Type	Liquid Parameter		Target Value		Delta (%)		Tolerance (%)
		$\epsilon_r$	O (S/m)	$\epsilon_r$	O (S/m)	$\Delta\epsilon_r$	$\Delta O$ (S/m)	
1710.7	Head	40.448	1.36	40.8	1.37	-0.86	-0.73	±5
	Body	53.48	1.463	53.43	1.49	0.09	-1.81	±5
1712.4	Head	40.435	1.362	40.8	1.37	-0.89	-0.58	±5
	Body	53.476	1.465	53.43	1.49	0.09	-1.68	±5
1732.5	Head	40.425	1.378	40.8	1.37	-0.92	0.58	±5
	Body	53.415	1.481	53.43	1.49	-0.03	-0.6	±5
1732.6	Head	40.421	1.379	40.8	1.37	-0.93	0.66	±5
	Body	53.408	1.481	53.43	1.49	-0.04	-0.6	±5
1752.6	Head	40.333	1.389	40.8	1.37	-1.14	1.39	±5
	Body	53.324	1.492	53.43	1.49	-0.2	0.13	±5
1754.3	Head	40.309	1.388	40.8	1.37	-1.2	1.31	±5
	Body	53.318	1.493	53.43	1.49	-0.21	0.2	±5
1850.2	Head	39.855	1.359	40	1.4	-0.36	-2.93	±5
	Body	55.298	1.478	53.3	1.52	3.75	-2.76	±5
1852.4	Head	39.856	1.356	40	1.4	-0.36	-3.14	±5
	Body	55.223	1.474	53.3	1.52	3.61	-3.03	±5
1960	Head	39.824	1.367	40	1.4	-0.44	-2.36	±5
	Body	54.433	1.465	53.3	1.52	2.13	-3.62	±5
1880	Head	39.742	1.386	40	1.4	-0.65	-1	±5
	Body	53.741	1.545	53.3	1.52	0.83	1.64	±5
1900	Head	39.683	1.412	40	1.4	-0.79	0.86	±5
	Body	54.172	1.516	53.3	1.52	1.64	-0.26	±5
1907.6	Head	39.58	1.41	40	1.4	-1.05	0.71	±5
	Body	53.601	1.492	53.3	1.52	0.56	-1.84	±5
1909.8	Head	39.588	1.412	40	1.4	-1.03	0.86	±5
	Body	53.379	1.491	53.3	1.52	0.15	-1.91	±5

\*Liquid Verification above was performed on 2015-09-08.

Frequency	Liquid Type	Liquid Parameter		Target Value		Delta (%)		Tolerance (%)
		$\epsilon_r$	O (S/m)	$\epsilon_r$	O (S/m)	$\Delta\epsilon_r$	$\Delta O$ (S/m)	
2450	Head	39.083	1.827	39.2	1.8	-0.3	1.5	±5
	Body	52.225	2.027	52.7	1.95	-0.9	3.95	±5
2510	Head	39.35	1.78	40.08	1.8	-1.82	-1.11	±5
	Body	52.86	1.91	53.43	1.95	-1.07	-2.05	±5
2535	Head	39.19	1.81	40.08	1.8	-2.22	0.56	±5
	Body	52.69	1.95	53.43	1.95	-1.38	0	±5
2560	Head	39.02	1.82	40.08	1.8	-2.64	1.11	±5
	Body	52.44	1.97	53.43	1.95	-1.85	1.03	±5

\*Liquid Verification above was performed on 2015-09-09.

Please refer to the following tables.

835 MHz Head			835 MHz Body		
Frequency (MHz)	e'	e''	Frequency (MHz)	e'	e''
824	42.8901	19.1661	824	55.1348	21.0708
824.5	42.9714	19.1336	824.5	55.1428	20.9457
825	42.952	19.1243	825	55.1332	20.9991
825.5	42.9208	19.2031	825.5	55.1839	20.9925
826	42.9341	19.1464	826	55.1174	21.0663
826.5	42.8592	19.1314	826.5	55.1399	20.9992
827	42.903	19.1548	827	55.0163	20.9925
827.5	42.8976	19.1795	827.5	55.1693	20.9844
828	42.9673	19.2028	828	55.1402	20.9879
828.5	42.9407	19.1667	828.5	55.1955	20.997
829	42.9584	19.253	829	55.0973	20.9157
829.5	42.9175	19.1355	829.5	55.0679	20.9144
830	42.9891	19.2042	830	55.1336	20.9779
830.5	42.9575	19.2331	830.5	55.1071	20.968
831	42.9203	19.1798	831	55.1275	20.9489
831.5	42.8796	19.1979	831.5	55.1317	20.9604
832	42.9777	19.1871	832	55.1948	20.9634
832.5	42.9403	19.2375	832.5	55.0992	20.9353
833	42.9635	19.2193	833	55.1244	20.913
833.5	42.9415	19.2541	833.5	55.1072	20.9415
834	42.8805	19.2256	834	55.148	21.0426
834.5	42.8743	19.2216	834.5	55.0869	20.9636
835	42.9702	19.2478	835	55.0721	20.9704
835.5	42.9164	19.1356	835.5	55.101	21.0023
836	42.9505	19.1515	836	55.0994	20.9929
836.5	42.8714	19.1866	836.5	55.107	20.9873
837	42.8619	19.2031	837	55.1124	20.9699
837.5	42.8586	19.2106	837.5	55.0306	20.9083
838	42.8444	19.2148	838	55.1199	20.9834
838.5	42.9105	19.2117	838.5	55.1326	21.0279
839	42.9298	19.2116	839	55.1027	20.9905
839.5	42.9328	19.1434	839.5	55.0709	21.02
840	42.9293	19.1419	840	55.0314	21.0144
840.5	42.864	19.077	840.5	55.1797	20.9683
841	42.9261	19.1901	841	55.0457	21.0031
841.5	42.899	19.1471	841.5	55.0348	20.9554
842	42.9054	19.1115	842	55.0977	20.9714
842.5	42.8366	19.1355	842.5	54.997	20.9938
843	42.8382	19.0654	843	55.0355	20.9733
843.5	42.833	19.0868	843.5	55.0354	20.9475
844	42.802	19.0843	844	55.0639	20.9129
844.5	42.8526	18.9978	844.5	55.0755	21.0423
845	42.755	19.0909	845	55.115	20.9832
845.5	42.8338	19.0901	845.5	55.0079	20.9026
846	42.8591	19.0004	846	55.0233	20.9589
846.5	42.8131	18.9924	846.5	55.0333	20.9018
847	42.7602	19.0738	847	55.0371	20.9685
847.5	42.7341	18.9801	847.5	55.0417	20.9725
848	42.8193	19.0139	848	54.9826	20.9864
848.5	42.7057	19.021	848.5	54.9729	20.9052
849	42.6978	18.9776	849	55.0073	20.9342

1750 MHz Head					
Frequency (MHz)	e'	e''	Frequency (MHz)	e'	e''
1710	40.4452	14.2963	1748	40.235	14.1982
1711	40.4495	14.3030	1749	40.2527	14.2482
1712	40.4431	14.3057	1750	40.3641	14.2497
1713	40.4218	14.2946	1751	40.3688	14.2355
1714	40.4189	14.2718	1752	40.3419	14.2563
1715	40.4036	14.2873	1753	40.3278	14.2438
1716	40.4673	14.3306	1754	40.297	14.2277
1717	40.3993	14.2807	1755	40.3355	14.2204
1718	40.4456	14.3187	1756	40.317	14.2816
1719	40.3843	14.3516	1757	40.2964	14.2277
1720	40.4455	14.3194	1758	40.2197	14.1683
1721	40.5764	14.2324	1759	40.2202	14.1843
1722	40.5246	14.2861	1760	40.273	14.1734
1723	40.5125	14.2689	1761	40.2818	14.3291
1724	40.595	14.2448	1762	40.2947	14.2804
1725	40.5375	14.2791	1763	40.2485	14.2817
1726	40.577	14.2396	1764	40.1933	14.2599
1727	40.4406	14.2924	1765	40.1927	14.2626
1728	40.4889	14.2921	1766	40.2253	14.3033
1729	40.5102	14.2474	1767	40.2095	14.2437
1730	40.4468	14.3268	1768	40.1822	14.2422
1731	40.3811	14.3537	1769	40.351	14.2742
1732	40.4498	14.2930	1770	40.3426	14.2025
1733	40.401	14.3210	1771	40.3335	14.2529
1734	40.3834	14.2847	1772	40.3395	14.2647
1735	40.3858	14.3074	1773	40.3025	14.2891
1736	40.3959	14.2588	1774	40.3169	14.2734
1737	40.3478	14.3037	1775	40.3064	14.2406
1738	40.3335	14.3277	1776	40.297	14.2580
1739	40.3447	14.3313	1777	40.2056	14.1915
1740	40.3246	14.3087	1778	40.2411	14.2760
1741	40.3365	14.2679	1779	40.2584	14.2128
1742	40.3219	14.3022	1780	40.3675	14.2496
1743	40.3003	14.2893	1781	40.3778	14.1869
1744	40.309	14.3131	1782	40.3557	14.2869
1745	40.3037	14.2858	1783	40.3148	14.2226
1746	40.2792	14.2188	1784	40.2805	14.1782
1747	40.2014	14.2946	1785	40.3515	14.2148

1750 MHz Body					
Frequency (MHz)	e'	e''	Frequency (MHz)	e'	e''
1710	53.4884	15.3678	1748	53.205	15.295
1711	53.476	15.3856	1749	53.2439	15.3354
1712	53.501	15.4072	1750	53.3377	15.3284
1713	53.4379	15.365	1751	53.3455	15.3386
1714	53.4236	15.3876	1752	53.3426	15.319
1715	53.3874	15.3802	1753	53.3118	15.3048
1716	53.5132	15.3707	1754	53.3069	15.3196
1717	53.4205	15.3503	1755	53.345	15.2713
1718	53.5003	15.3526	1756	53.3061	15.3281
1719	53.4189	15.4005	1757	53.2692	15.3097
1720	53.4887	15.3797	1758	53.2224	15.2437
1721	53.6968	15.3305	1759	53.2113	15.2487
1722	53.5837	15.3317	1760	53.2519	15.2696
1723	53.5863	15.3387	1761	53.245	15.3876
1724	53.6646	15.285	1762	53.3123	15.3318
1725	53.6007	15.3123	1763	53.2036	15.3445
1726	53.6419	15.266	1764	53.1859	15.3234
1727	53.4878	15.3548	1765	53.1323	15.3601
1728	53.521	15.3936	1766	53.1834	15.3754
1729	53.5454	15.3222	1767	53.1879	15.316
1730	53.4943	15.4058	1768	53.1483	15.3165
1731	53.4272	15.4123	1769	53.3869	15.3677
1732	53.4486	15.3864	1770	53.3678	15.2698
1733	53.3809	15.3712	1771	53.3387	15.3319
1734	53.4096	15.3291	1772	53.3457	15.3395
1735	53.4128	15.3788	1773	53.2819	15.3316
1736	53.4489	15.3435	1774	53.3138	15.323
1737	53.3991	15.3304	1775	53.3154	15.3046
1738	53.3312	15.3839	1776	53.2615	15.3277
1739	53.3656	15.3719	1777	53.1947	15.2514
1740	53.3684	15.3604	1778	53.1941	15.3667
1741	53.3546	15.341	1779	53.2112	15.2825
1742	53.3197	15.3257	1780	53.3834	15.3126
1743	53.28	15.3569	1781	53.3966	15.2747
1744	53.3273	15.4148	1782	53.355	15.3286
1745	53.307	15.3567	1783	53.2926	15.2755
1746	53.2588	15.3058	1784	53.2984	15.2442
1747	53.208	15.3459	1785	53.3445	15.2599

1900 MHz Head			1900 MHz Body		
Frequency (MHz)	e'	e''	Frequency (MHz)	e'	e''
1850	39.8451	13.2129	1850	55.2832	14.3825
1851	39.897	13.2202	1851	55.3569	14.3258
1852	39.8524	13.1777	1852	55.2539	14.3401
1853	39.8612	13.1448	1853	55.1754	14.2704
1854	39.8741	13.1617	1854	55.0718	14.1573
1855	39.8975	13.2067	1855	55.0745	14.2283
1856	39.87	13.1656	1856	54.9032	14.293
1857	39.9203	13.2172	1857	54.7318	14.2057
1858	39.8418	13.1898	1858	54.6315	14.1136
1859	39.8248	13.1888	1859	54.5769	14.0444
1860	39.8238	13.2133	1860	54.4325	14.1665
1861	39.8692	13.2401	1861	54.5089	14.1066
1862	39.9161	13.2391	1862	54.3594	14.1324
1863	39.8495	13.1571	1863	54.2044	14.143
1864	39.8279	13.16	1864	54.1693	14.1371
1865	39.8409	13.204	1865	54.0664	14.1355
1866	39.7865	13.2066	1866	53.9603	14.1591
1867	39.8116	13.1946	1867	53.9103	14.1523
1868	39.7957	13.2011	1868	53.8467	14.2537
1869	39.856	13.2747	1869	53.7204	14.2284
1870	39.8643	13.2228	1870	53.6884	14.2791
1871	39.8237	13.1863	1871	53.6574	14.2778
1872	39.8037	13.2033	1872	53.6763	14.3483
1873	39.8275	13.1831	1873	53.6488	14.4502
1874	39.722	13.2615	1874	53.6194	14.4373
1875	39.7906	13.2318	1875	53.6115	14.4646
1876	39.7515	13.2399	1876	53.6431	14.5479
1877	39.8178	13.2573	1877	53.6485	14.6217
1878	39.7652	13.2373	1878	53.6254	14.6915
1879	39.7596	13.2557	1879	53.6833	14.6565
1880	39.7421	13.2627	1880	53.7412	14.7807
1881	39.7491	13.2301	1881	53.7384	14.7639
1882	39.7545	13.247	1882	53.7787	14.8174
1883	39.7253	13.2758	1883	53.8067	14.7754
1884	39.7322	13.2617	1884	53.9017	14.8027
1885	39.6938	13.3112	1885	53.9431	14.8264
1886	39.7024	13.3178	1886	54.0877	14.7775
1887	39.6732	13.3025	1887	54.1639	14.7837
1888	39.6841	13.285	1888	54.259	14.8014
1889	39.6916	13.3054	1889	54.2432	14.7381
1890	39.6728	13.3022	1890	54.2826	14.7361
1891	39.6763	13.3105	1891	54.3189	14.7141
1892	39.6752	13.2916	1892	54.3586	14.713
1893	39.6399	13.322	1893	54.3408	14.6927
1894	39.6814	13.2851	1894	54.3415	14.6336
1895	39.6425	13.2821	1895	54.3203	14.5939
1896	39.693	13.2909	1896	54.4484	14.5173
1897	39.6559	13.2899	1897	54.4201	14.4829
1898	39.6273	13.3159	1898	54.4381	14.4208
1899	39.6449	13.2875	1899	54.2637	14.4092
1900	39.6831	13.3694	1900	54.172	14.3455

1900 MHz Head			1900 MHz Body		
Frequency (MHz)	e'	e''	Frequency (MHz)	e'	e''
1901	39.6377	13.311	1901	54.1205	14.2704
1902	39.6103	13.3407	1902	54.0842	14.2389
1903	39.6387	13.2671	1903	53.944	14.2061
1904	39.6658	13.3455	1904	53.872	14.103
1905	39.6259	13.3223	1905	53.7592	14.1169
1906	39.5898	13.3481	1906	53.6916	14.1068
1907	39.5417	13.2925	1907	53.6365	14.0953
1908	39.6063	13.2943	1908	53.5778	14.043
1909	39.5739	13.3313	1909	53.4285	14.0464
1910	39.592	13.2906	1910	53.3664	14.0357

2450 MHz Head					
Frequency (MHz)	e'	e''	Frequency (MHz)	e'	e''
2412	39.3558	13.3583	2443	39.1526	13.4423
2413	39.2784	13.3362	2444	39.1711	13.4194
2414	39.353	13.3308	2445	39.189	13.4374
2415	39.3212	13.405	2446	39.1376	13.4208
2416	39.3129	13.3521	2447	39.159	13.4582
2417	39.3495	13.3842	2448	39.1173	13.4408
2418	39.314	13.3731	2449	39.1424	13.4467
2419	39.3292	13.369	2450	39.1317	13.4173
2420	39.3578	13.412	2451	39.1126	13.4307
2421	39.2524	13.5016	2452	39.1106	13.425
2422	39.2388	13.5014	2453	39.1139	13.4261
2423	39.2088	13.5004	2454	39.1246	13.4059
2424	39.2285	13.5033	2455	39.0732	13.3998
2425	39.198	13.4595	2456	39.0883	13.4486
2426	39.217	13.49	2457	39.0943	13.4208
2427	39.2196	13.4783	2458	39.0722	13.4186
2428	39.196	13.5159	2459	39.0521	13.4095
2429	39.1392	13.4763	2460	39.008	13.46
2430	39.2157	13.442	2461	39.0729	13.4522
2431	39.235	13.4936	2462	39.0327	13.4212
2432	39.2257	13.4621	2463	39.0428	13.4821
2433	39.2172	13.4979	2464	39.0341	13.4858
2434	39.2527	13.5051	2465	39.0237	13.5277
2435	39.2124	13.466	2466	39.0041	13.5215
2436	39.1651	13.4822	2467	38.9779	13.4878
2437	39.1646	13.4455	2468	39.0267	13.5022
2438	39.1939	13.4592	2469	38.9984	13.4796
2439	39.2141	13.4647	2470	38.9942	13.5085
2440	39.1833	13.4638	2471	39.0275	13.5108
2441	39.1821	13.4346	2472	38.9457	13.5433
2442	39.1899	13.4442	/	/	/



2450 MHz Body					
Frequency (MHz)	e'	e''	Frequency (MHz)	e'	e''
2412	53.2534	14.477	2443	51.7412	14.8703
2413	53.3643	14.4925	2444	51.7915	14.8644
2414	53.2647	14.4546	2445	51.8398	14.9029
2415	53.1831	14.4176	2446	51.8877	14.9075
2416	53.0495	14.2967	2447	51.9606	14.9385
2417	53.0178	14.3833	2448	52.0994	14.8754
2418	52.9436	14.4098	2449	52.1592	14.8866
2419	52.7701	14.2885	2450	52.2151	14.9145
2420	52.6322	14.2627	2451	52.2198	14.8615
2421	52.6154	14.1916	2452	52.309	14.8344
2422	52.4592	14.3372	2453	52.3424	14.8401
2423	52.4936	14.232	2454	52.3759	14.8005
2424	52.3206	14.2886	2455	52.3385	14.7647
2425	52.1782	14.2737	2456	52.3434	14.7616
2426	52.1467	14.2802	2457	52.3396	14.7609
2427	52.0435	14.2875	2458	52.4629	14.5841
2428	51.9853	14.2681	2459	52.3782	14.6132
2429	51.9133	14.3192	2460	52.407	14.5451
2430	51.8559	14.3309	2461	52.2504	14.5209
2431	51.7428	14.3074	2462	52.1992	14.4592
2432	51.6754	14.366	2463	52.1071	14.3973
2433	51.6621	14.4505	2464	52.0553	14.3711
2434	51.6849	14.4762	2465	51.9622	14.3416
2435	51.65	14.5438	2466	51.9139	14.2452
2436	51.5926	14.548	2467	51.7739	14.287
2437	51.6571	14.616	2468	51.7264	14.2183
2438	51.6508	14.6445	2469	51.6284	14.2375
2439	51.6725	14.7097	2470	51.5726	14.2231
2440	51.6009	14.7845	2471	51.4641	14.1627
2441	51.6691	14.7855	2472	51.3381	14.1899
2442	51.7308	14.8273	/	/	/

2550 MHz Head			2550 MHz Body		
Frequency (MHz)	e'	e''	Frequency (MHz)	e'	e''
2510	39.3485	12.738	2510	52.8589	13.6739
2511	39.2833	12.7456	2511	52.8079	13.7039
2512	39.3458	12.7181	2512	52.8595	13.7116
2513	39.3443	12.7313	2513	52.8778	13.7308
2514	39.3247	12.7304	2514	52.8625	13.7354
2515	39.359	12.7617	2515	52.9078	13.7126
2516	39.2979	12.7411	2516	52.8709	13.7095
2517	39.3159	12.7364	2517	52.8828	13.7302
2518	39.3388	12.7673	2518	52.8945	13.7656
2519	39.2438	12.8729	2519	52.7935	13.8509
2520	39.235	12.8513	2520	52.7635	13.8116
2521	39.1992	12.8605	2521	52.7157	13.8186
2522	39.2205	12.8535	2522	52.7245	13.8582
2523	39.1891	12.8649	2523	52.7186	13.8205
2524	39.1851	12.8533	2524	52.7094	13.8541
2525	39.2359	12.8809	2525	52.7283	13.8368
2526	39.1703	12.888	2526	52.64	13.8506
2527	39.1639	12.8267	2527	52.6248	13.8522
2528	39.2118	12.8632	2528	52.6997	13.8239
2529	39.2336	12.8795	2529	52.7044	13.8229
2530	39.2532	12.8513	2530	52.7675	13.8328
2531	39.223	12.863	2531	52.7542	13.8312
2532	39.2364	12.8486	2532	52.7625	13.8308
2533	39.2162	12.8555	2533	52.7068	13.8414
2534	39.1693	12.8544	2534	52.6759	13.8493
2535	39.1919	12.8106	2535	52.6912	13.8028
2536	39.1663	12.8251	2536	52.6853	13.8019
2537	39.201	12.8266	2537	52.6878	13.8547
2538	39.2103	12.8369	2538	52.7019	13.7715
2539	39.2024	12.7961	2539	52.6603	13.8184
2540	39.1675	12.816	2540	52.6702	13.8051
2541	39.1486	12.8115	2541	52.6691	13.8289
2542	39.1751	12.7845	2542	52.6663	13.7916
2543	39.1548	12.8218	2543	52.6552	13.8185
2544	39.1621	12.8052	2544	52.6511	13.7725
2545	39.1444	12.8001	2545	52.6494	13.7806
2546	39.1608	12.7968	2546	52.608	13.7938
2547	39.1407	12.809	2547	52.615	13.7999
2548	39.0895	12.7978	2548	52.5875	13.7576
2549	39.1162	12.8004	2549	52.6138	13.8097
2550	39.1416	12.7821	2550	52.5933	13.7564
2551	39.0995	12.7753	2551	52.5646	13.7739
2552	39.0871	12.7857	2552	52.5802	13.7844
2553	39.0686	12.7949	2553	52.5464	13.7607
2554	39.0784	12.7959	2554	52.5497	13.7686
2555	39.0618	12.7796	2555	52.5527	13.7606
2556	39.0496	12.7942	2556	52.5138	13.7841
2557	39.0352	12.8167	2557	52.4954	13.7846
2558	39.006	12.8024	2558	52.4937	13.7937
2559	39.0347	12.8076	2559	52.5014	13.7712
2560	39.0167	12.8075	2560	52.4411	13.8176

2550 MHz Head			2550 MHz Body		
Frequency (MHz)	e'	e''	Frequency (MHz)	e'	e''
2561	39.0142	12.8432	2561	52.4541	13.787
2562	39.0219	12.8475	2562	52.4632	13.8204
2563	39.0174	12.8016	2563	52.4596	13.7377
2564	39.0313	12.8385	2564	52.5111	13.7517
2565	39.0269	12.8369	2565	52.4942	13.7648
2566	39.0361	12.8527	2566	52.4486	13.7906
2567	39.0258	12.8095	2567	52.4173	13.754
2568	38.9824	12.8509	2568	52.4245	13.7598
2569	39.0149	12.8012	2569	52.4392	13.7936
2570	38.9646	12.8303	2570	52.3963	13.8046

FINAL

### System Accuracy Verification

Prior to the assessment, the system validation kit was used to test whether the system was operating within its specifications of  $\pm 10\%$ . The validation results are tabulated below. And also the corresponding SAR plot is attached as well in the SAR plots files.

### System Verification Setup Block Diagram

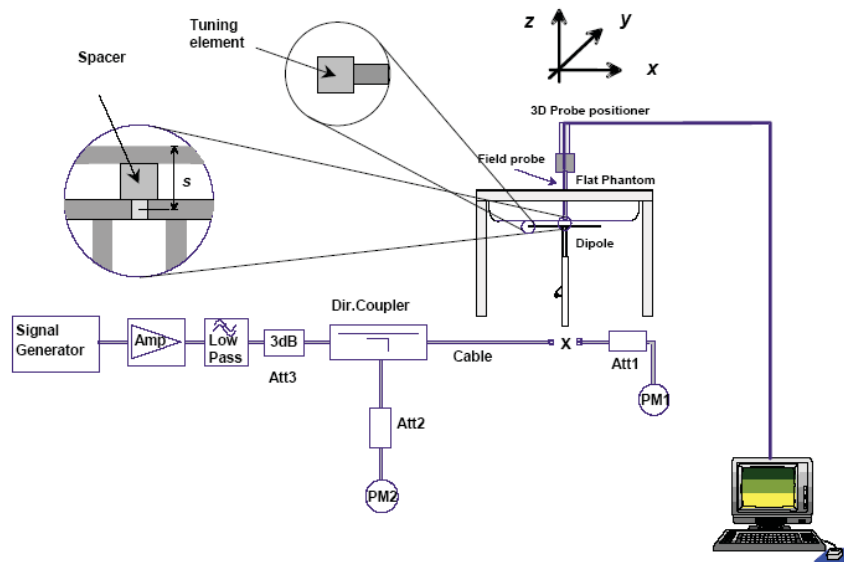

### System Accuracy Check Results

Date	Frequency Band	Liquid Type	Measured SAR (W/Kg)		Target Value (W/Kg)	Delta (%)	Tolerance (%)
2015-09-07	835	Head	1g	9.23	9.43	-2.12	$\pm 10$
		Body	1g	9.32	9.55	-2.41	$\pm 10$
2015-09-08	1750	Head	1g	37.8	36.8	2.72	$\pm 10$
		Body	1g	37.1	37.4	-0.80	$\pm 10$
	1900	Head	1g	40.2	40.7	-1.23	$\pm 10$
		Body	1g	41.2	40.8	0.98	$\pm 10$
2015-09-09	2450	Head	1g	54	53.3	1.31	$\pm 10$
		Body	1g	52	50.6	2.77	$\pm 10$

\*All SAR values are normalized to 1 Watt forward power.

**SAR SYSTEM VALIDATION DATA**

**Test Laboratory: Bay Area Compliance Labs Corp.(Dongguan)**

**System Performance 835 MHz Head**

**DUT:D835V1; Type: 835 MHz; Serial:453**

Communication System: CW; Frequency: 835 MHz;Duty Cycle: 1:1

Medium parameters used: f = 835 MHz;  $\sigma = 0.894$  S/m;  $\epsilon_r = 42.97$ ;  $\rho = 1000$  kg/m<sup>3</sup>

Phantom section: Flat Section

DASY5 Configuration:

- Probe: EX3DV4 - SN7329; ConvF(9.52, 9.52, 9.52); Calibrated: 2015/2/5;
- Sensor-Surface: 4mm (Mechanical Surface Detection)
- Electronics: DAE4 Sn1459; Calibrated: 2015/1/26
- Phantom: SAM (30deg probe tilt) with CRP v5.0\_20150321; Type: QD000P40CD; Serial: TP:1874
- Measurement SW: DASY52, Version 52.8 (8);

**System Performance 835 MHz Head /Area Scan (71x131x1):** Interpolated grid: dx=1.500 mm, dy=1.500 mm  
 Maximum value of SAR (interpolated) = 10.4 W/kg

**System Performance 835 MHz Head /Zoom Scan (7x7x7)/Cube 0:** Measurement grid: dx=5mm, dy=5mm, dz=5mm

Reference Value = 107.3 V/m; Power Drift = 0.08 dB

Peak SAR (extrapolated) = 15.3 W/kg

**SAR(1 g) = 9.23 W/kg; SAR(10 g) = 6.12 W/kg**

Maximum value of SAR (measured) = 10.7 W/kg

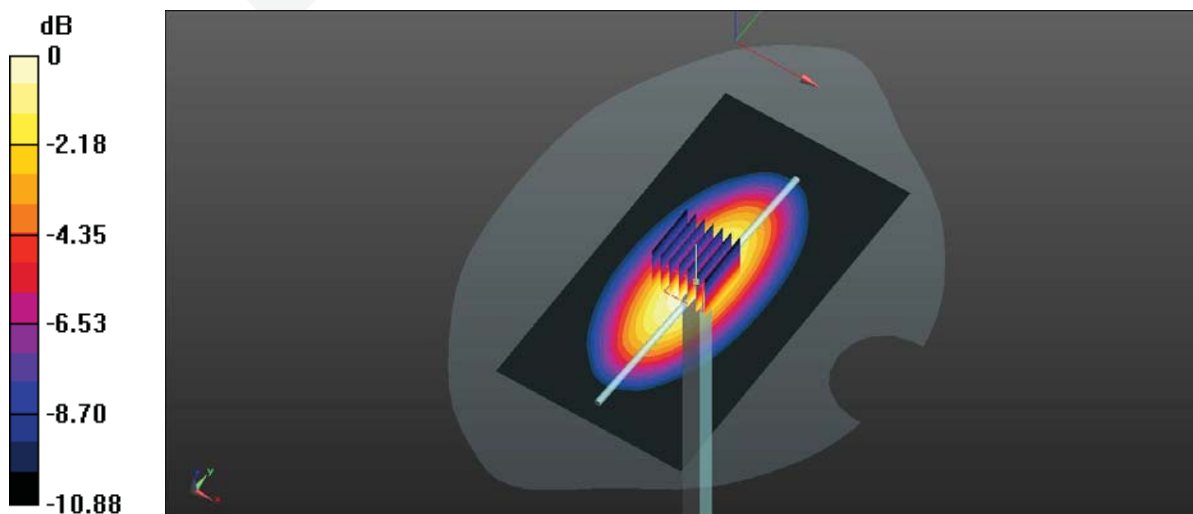

0 dB = 10.7 W/kg = 10.29 dBW/kg

**Test Laboratory: Bay Area Compliance Labs Corp.(Dongguan)**

**System Performance 835 MHz Body**

**DUT:D835V1; Type: 835 MHz; Serial:453**

Communication System: CW; Frequency: 835 MHz;Duty Cycle: 1:1  
 Medium parameters used:  $f = 835 \text{ MHz}$ ;  $\sigma = 0.974 \text{ S/m}$ ;  $\epsilon_r = 55.072$ ;  $\rho = 1000 \text{ kg/m}^3$   
 Phantom section: Flat Section

DASY5 Configuration:

- Probe: EX3DV4 - SN7329; ConvF(9.17, 9.17, 9.17); Calibrated: 2015/2/5;
- Sensor-Surface: 4mm (Mechanical Surface Detection)
- Electronics: DAE4 Sn1459; Calibrated: 2015/1/26
- Phantom: SAM (30deg probe tilt) with CRP v5.0\_20150321; Type: QD000P40CD; Serial: TP:1874
- Measurement SW: DASY52, Version 52.8 (8);

**System Performance 835 MHz Body /Area Scan (71x131x1):** Interpolated grid:  $dx=1.500 \text{ mm}$ ,  $dy=1.500 \text{ mm}$   
 Maximum value of SAR (interpolated) = 10.26 W/kg

**System Performance 835 MHz Body /Zoom Scan (7x7x7)/Cube 0:** Measurement grid:  $dx=5\text{mm}$ ,  $dy=5\text{mm}$ ,  $dz=5\text{mm}$

Reference Value = 104.47 V/m; Power Drift = 0.02 dB

Peak SAR (extrapolated) = 14.9 W/kg

**SAR(1 g) = 9.32 W/kg; SAR(10 g) = 6.22 W/kg**

Maximum value of SAR (measured) = 10.6 W/kg

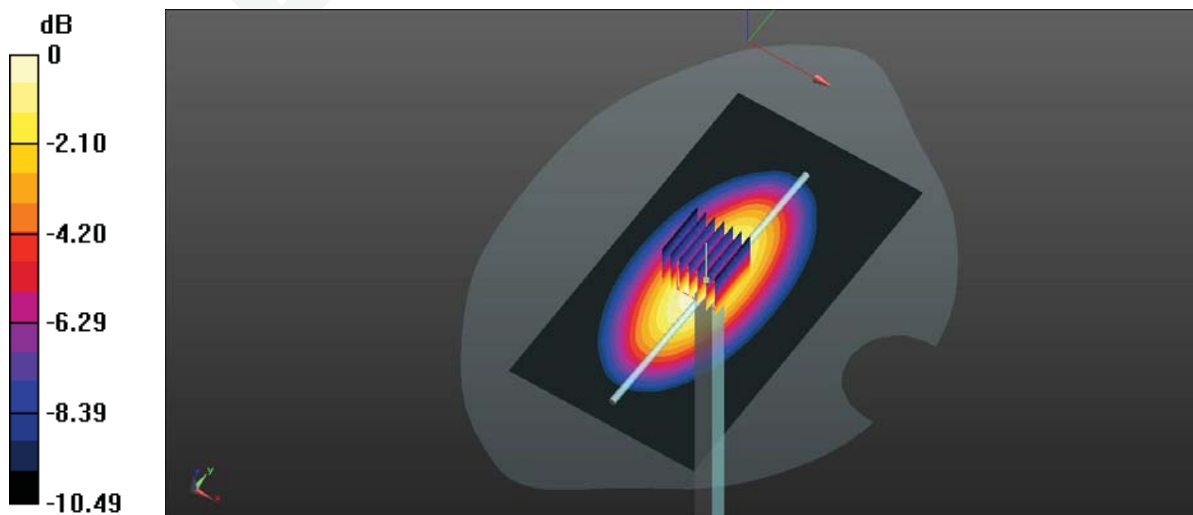

0 dB = 10.6 W/kg = 10.25 dBW/kg

**Test Laboratory: Bay Area Compliance Labs Corp.(Dongguan)**

**System Performance 1750 MHz Head**

**DUT: D1750V2; Type: 1750 MHz; Serial: 1141**

Communication System: CW; Frequency: 1750 MHz;Duty Cycle: 1:1  
 Medium parameters used:  $f = 1750 \text{ MHz}$ ;  $\sigma = 1.387 \text{ S/m}$ ;  $\epsilon_r = 40.364$ ;  $\rho = 1000 \text{ kg/m}^3$   
 Phantom section: Flat Section

DASY5 Configuration:

- Probe: EX3DV4 - SN7329; ConvF(8.12, 8.12, 8.12); Calibrated: 2015/2/5;
- Sensor-Surface: 4mm (Mechanical Surface Detection)
- Electronics: DAE4 Sn1459; Calibrated: 2015/1/26
- Phantom: SAM (30deg probe tilt) with CRP v5.0\_20150321; Type: QD000P40CD; Serial: TP:1874
- Measurement SW: DASY52, Version 52.8 (8);

**System Performance 1750 MHz Head /Area Scan (61x81x1):** Interpolated grid:  $dx=1.500 \text{ mm}$ ,  $dy=1.500 \text{ mm}$   
 Maximum value of SAR (interpolated) = 45.3 W/kg

**System Performance 1750 MHz Head /Zoom Scan (7x7x7)/Cube 0:** Measurement grid:  $dx=5\text{mm}$ ,  $dy=5\text{mm}$ ,  $dz=5\text{mm}$

Reference Value = 162.0 V/m; Power Drift = -0.03 dB

Peak SAR (extrapolated) = 72.6 W/kg

**SAR(1 g) = 37.8 W/kg; SAR(10 g) = 20.1 W/kg**

Maximum value of SAR (measured) = 44.7 W/kg

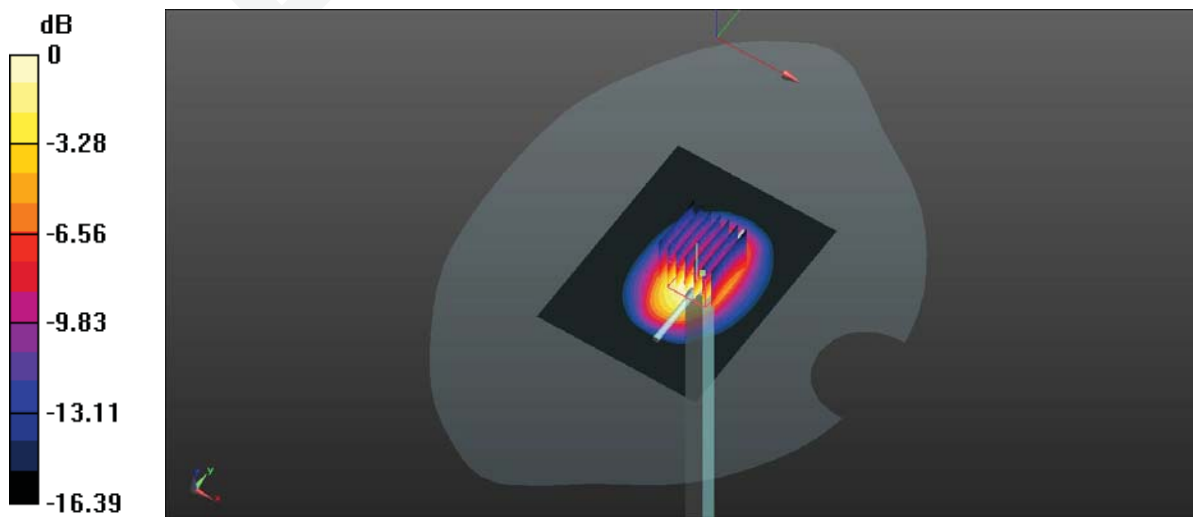

0 dB = 44.7 W/kg = 16.50 dBW/kg

**Test Laboratory: Bay Area Compliance Labs Corp.(Dongguan)**

**System Performance 1750 MHz Body**

**DUT: D1750V2; Type: 1750 MHz; Serial: 1141**

Communication System: CW; Frequency: 1750 MHz;Duty Cycle: 1:1  
 Medium parameters used:  $f = 1750 \text{ MHz}$ ;  $\sigma = 1.492 \text{ S/m}$ ;  $\epsilon_r = 53.338$ ;  $\rho = 1000 \text{ kg/m}^3$   
 Phantom section: Flat Section

DASY5 Configuration:

- Probe: EX3DV4 - SN7329; ConvF(7.85, 7.85, 7.85); Calibrated: 2015/2/5;
- Sensor-Surface: 4mm (Mechanical Surface Detection)
- Electronics: DAE4 Sn1459; Calibrated: 2015/1/26
- Phantom: SAM (30deg probe tilt) with CRP v5.0\_20150321; Type: QD000P40CD; Serial: TP:1874
- Measurement SW: DASY52, Version 52.8 (8);

**System Performance 1750 MHz Body /Area Scan (61x81x1):** Interpolated grid:  $dx=1.500 \text{ mm}$ ,  $dy=1.500 \text{ mm}$   
 Maximum value of SAR (interpolated) = 42.3 W/kg

**System Performance 1750 MHz Body /Zoom Scan (7x7x7)/Cube 0:** Measurement grid:  $dx=5\text{mm}$ ,  $dy=5\text{mm}$ ,  $dz=5\text{mm}$

Reference Value = 164.4 V/m; Power Drift = 0.00 dB

Peak SAR (extrapolated) = 67.4 W/kg

**SAR(1 g) = 37.1 W/kg; SAR(10 g) = 20.3 W/kg**

Maximum value of SAR (measured) = 40.5 W/kg

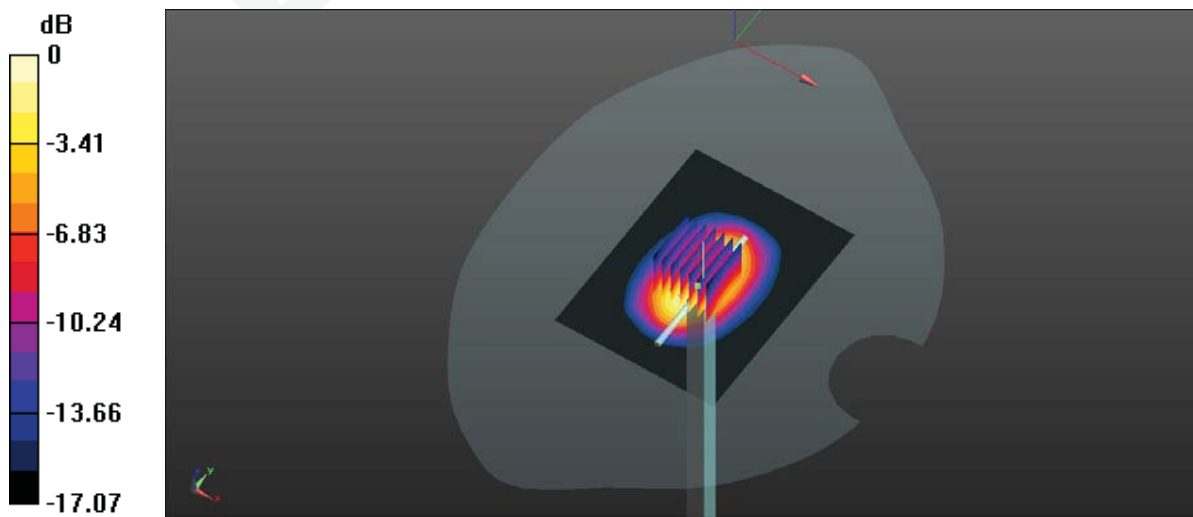

0 dB = 40.5 W/kg = 16.07 dBW/kg



**Test Laboratory: Bay Area Compliance Labs Corp.(Dongguan)**

**System Performance 1900 MHz Head**

**DUT: D1900V2; Type: 1900 MHz; Serial: 5d206**

Communication System: CW; Frequency: 1900 MHz;Duty Cycle: 1:1

Medium parameters used:  $f = 1900 \text{ MHz}$ ;  $\sigma = 1.413 \text{ S/m}$ ;  $\epsilon_r = 39.683$ ;  $\rho = 1000 \text{ kg/m}^3$

Phantom section: Flat Section

DASY5 Configuration:

- Probe: EX3DV4 - SN7329; ConvF(7.88, 7.88, 7.88); Calibrated: 2015/2/5;
- Sensor-Surface: 4mm (Mechanical Surface Detection)
- Electronics: DAE4 Sn1459; Calibrated: 2015/1/26
- Phantom: SAM (30deg probe tilt) with CRP v5.0\_20150321; Type: QD000P40CD; Serial: TP:1874
- Measurement SW: DASY52, Version 52.8 (8);

**System Performance 1900 MHz Head /Area Scan (61x81x1):** Interpolated grid:  $dx=1.500 \text{ mm}$ ,  $dy=1.500 \text{ mm}$

Maximum value of SAR (interpolated) = 45.8 W/kg

**System Performance 1900 MHz Head /Zoom Scan (7x7x7)/Cube 0:** Measurement grid:  $dx=5\text{mm}$ ,  $dy=5\text{mm}$ ,  $dz=5\text{mm}$

Reference Value = 169.7 V/m; Power Drift = -0.02 dB

Peak SAR (extrapolated) = 72.9 W/kg

**SAR(1 g) = 40.2 W/kg; SAR(10 g) = 20.9 W/kg**

Maximum value of SAR (measured) = 43.5 W/kg

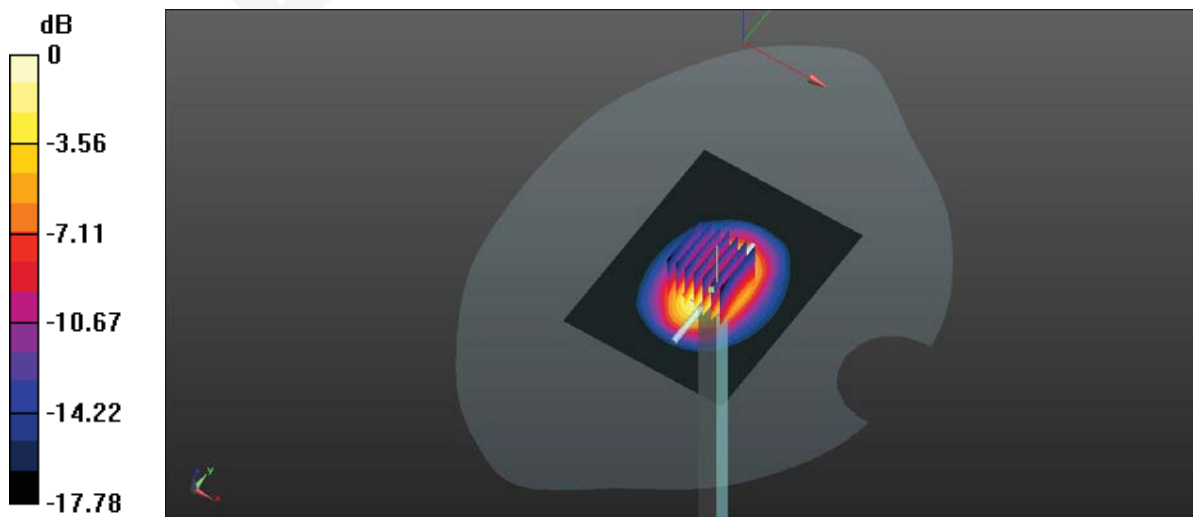

0 dB = 43.5 W/kg = 16.38 dBW/kg

**Test Laboratory: Bay Area Compliance Labs Corp.(Dongguan)**

**System Performance 1900 MHz Body**

**DUT: D1900V2; Type: 1900 MHz; Serial: 5d206**

Communication System: CW; Frequency: 1900 MHz;Duty Cycle: 1:1  
 Medium parameters used:  $f = 1900 \text{ MHz}$ ;  $\sigma = 1.516 \text{ S/m}$ ;  $\epsilon_r = 54.172$ ;  $\rho = 1000 \text{ kg/m}^3$   
 Phantom section: Flat Section

DASY5 Configuration:

- Probe: EX3DV4 - SN7329; ConvF(7.56, 7.56, 7.56); Calibrated: 2015/2/5;
- Sensor-Surface: 4mm (Mechanical Surface Detection)
- Electronics: DAE4 Sn1459; Calibrated: 2015/1/26
- Phantom: SAM (30deg probe tilt) with CRP v5.0\_20150321; Type: QD000P40CD; Serial: TP:1874
- Measurement SW: DASY52, Version 52.8 (8);

**System Performance 1900 MHz Body /Area Scan (61x81x1):** Interpolated grid:  $dx=1.500 \text{ mm}$ ,  $dy=1.500 \text{ mm}$   
 Maximum value of SAR (interpolated) = 48.7 W/kg

**System Performance 1900 MHz Body /Zoom Scan (7x7x7)/Cube 0:** Measurement grid:  $dx=5\text{mm}$ ,  $dy=5\text{mm}$ ,  $dz=5\text{mm}$

Reference Value = 171.8 V/m; Power Drift = 0.14 dB

Peak SAR (extrapolated) = 79.0 W/kg

**SAR(1 g) = 41.7 W/kg; SAR(10 g) = 21.2 W/kg**

Maximum value of SAR (measured) = 47.0 W/kg

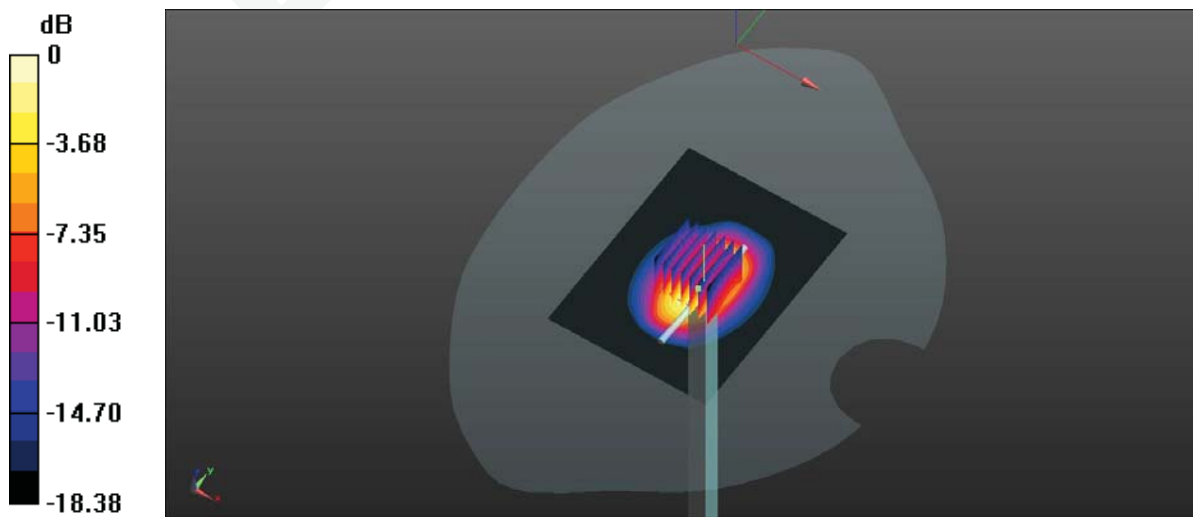

0 dB = 47.0 W/kg = 16.72 dBW/kg

**Test Laboratory: Bay Area Compliance Labs Corp.(Dongguan)**

**System Performance 2450 MHz Head**

**DUT: D2450V3; Type: 2450 MHz; Serial: 971**

Communication System: CW; Frequency: 2450 MHz;Duty Cycle: 1:1  
 Medium parameters used:  $f = 2450 \text{ MHz}$ ;  $\sigma = 1.779 \text{ S/m}$ ;  $\epsilon_r = 39.349$ ;  $\rho = 1000 \text{ kg/m}^3$   
 Phantom section: Flat Section

DASY5 Configuration:

- Probe: EX3DV4 - SN7329; ConvF(7.06, 7.06, 7.06); Calibrated: 2015/2/5;
- Sensor-Surface: 4mm (Mechanical Surface Detection)
- Electronics: DAE4 Sn1459; Calibrated: 2015/1/26
- Phantom: SAM (30deg probe tilt) with CRP v5.0\_20150321; Type: QD000P40CD; Serial: TP:1874
- Measurement SW: DASY52, Version 52.8 (8);

**System Performance 2450 MHz Head /Area Scan (61x81x1):** Interpolated grid:  $dx=1.000 \text{ mm}$ ,  $dy=1.000 \text{ mm}$   
 Maximum value of SAR (interpolated) = 64.3 W/kg

**System Performance 2450 MHz Head /Zoom Scan (7x7x7)/Cube 0:** Measurement grid:  $dx=5\text{mm}$ ,  $dy=5\text{mm}$ ,  $dz=5\text{mm}$

Reference Value = 187.6 V/m; Power Drift = -0.03 dB

Peak SAR (extrapolated) = 111 W/kg

**SAR(1 g) = 54 W/kg; SAR(10 g) = 24.6 W/kg**

Maximum value of SAR (measured) = 61.8 W/kg

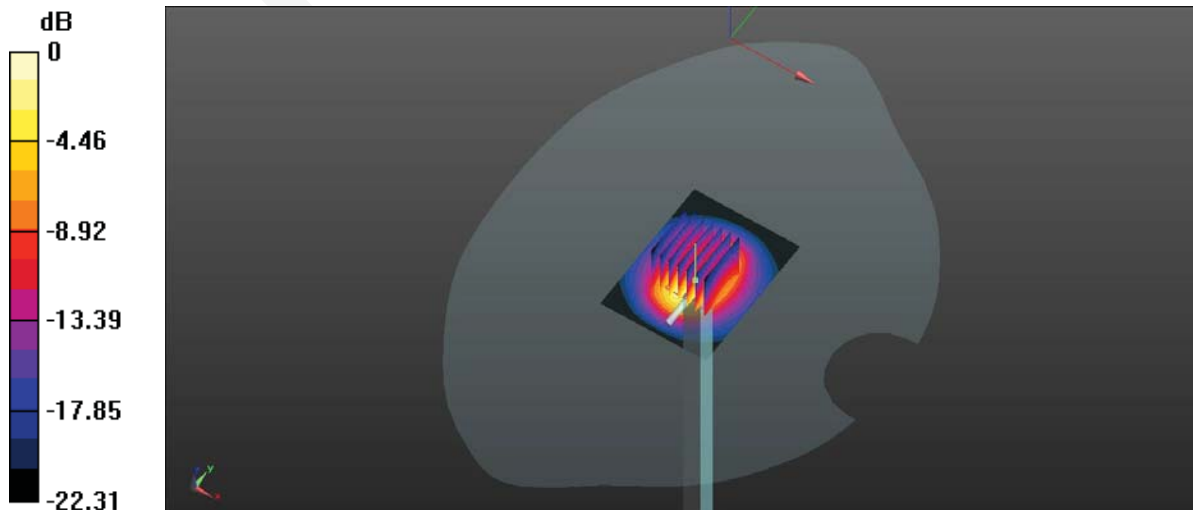

0 dB = 61.8 W/kg = 17.91 dBW/kg

**Test Laboratory: Bay Area Compliance Labs Corp.(Dongguan)**

**System Performance 2450 MHz Body**

**DUT: D2450V3; Type: 2450 MHz; Serial: 971**

Communication System: CW; Frequency: 2450 MHz;Duty Cycle: 1:1

Medium parameters used:  $f = 2450 \text{ MHz}$ ;  $\sigma = 1.909 \text{ S/m}$ ;  $\epsilon_r = 52.859$ ;  $\rho = 1000 \text{ kg/m}^3$

Phantom section: Flat Section

DASY5 Configuration:

- Probe: EX3DV4 - SN7329; ConvF(7.2, 7.2, 7.2); Calibrated: 2015/2/5;
- Sensor-Surface: 4mm (Mechanical Surface Detection)
- Electronics: DAE4 Sn1459; Calibrated: 2015/1/26
- Phantom: SAM (30deg probe tilt) with CRP v5.0\_20150321; Type: QD000P40CD; Serial: TP:1874
- Measurement SW: DASY52, Version 52.8 (8);

**System Performance 2450 MHz Body /Area Scan (61x81x1):** Interpolated grid:  $dx=1.000 \text{ mm}$ ,  $dy=1.000 \text{ mm}$

Maximum value of SAR (interpolated) = 63.3 W/kg

**System Performance 2450 MHz Body /Zoom Scan (7x7x7)/Cube 0:** Measurement grid:  $dx=5\text{mm}$ ,  $dy=5\text{mm}$ ,  $dz=5\text{mm}$

Reference Value = 182.2 V/m; Power Drift = -0.28 dB

Peak SAR (extrapolated) = 107 W/kg

**SAR(1 g) = 52 W/kg; SAR(10 g) = 23.7 W/kg**

Maximum value of SAR (measured) = 59.5 W/kg

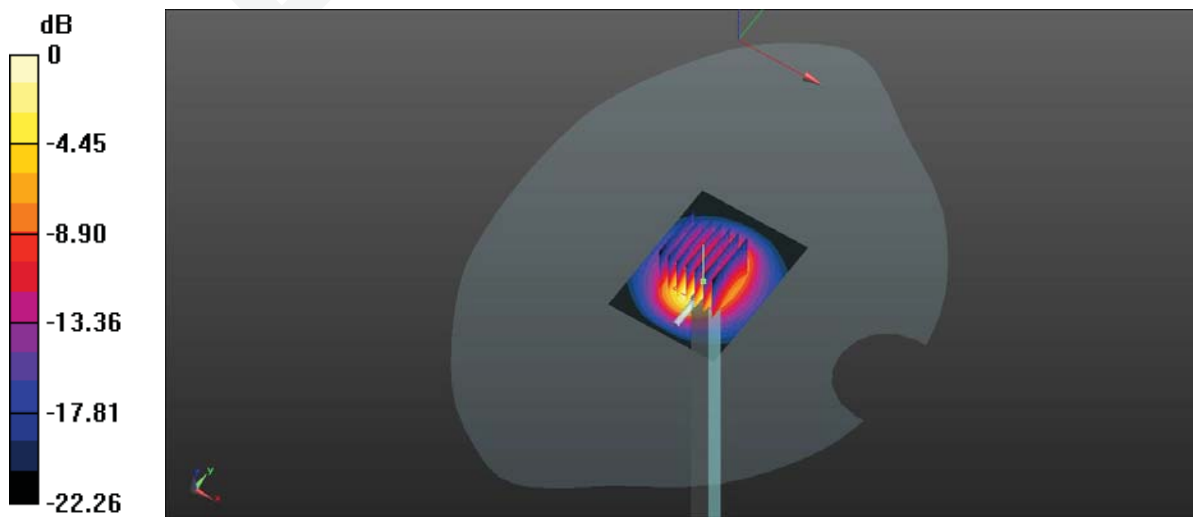

0 dB = 59.5 W/kg = 17.75 dBW/kg

## EUT TEST STRATEGY AND METHODOLOGY

### Test Positions for Device Operating Next to a Person’s Ear

This category includes most wireless handsets with fixed, retractable or internal antennas located toward the top half of the device, with or without a foldout, sliding or similar keypad cover. The handset should have its earpiece located within the upper ¼ of the device, either along the centerline or off-centered, as perceived by its users. This type of handset should be positioned in a normal operating position with the “test device reference point” located along the “vertical centerline” on the front of the device aligned to the “ear reference point”. The “test device reference point” should be located at the same level as the center of the earpiece region. The “vertical centerline” should bisect the front surface of the handset at its top and bottom edges. A “ear reference point” is located on the outer surface of the head phantom on each ear spacer. It is located 1.5 cm above the center of the ear canal entrance in the “phantom reference plane” defined by the three lines joining the center of each “ear reference point” (left and right) and the tip of the mouth.

A handset should be initially positioned with the earpiece region pressed against the ear spacer of a head phantom. For the SCC-34/SC-2 head phantom, the device should be positioned parallel to the “N-F” line defined along the base of the ear spacer that contains the “ear reference point”. For interim head phantoms, the device should be positioned parallel to the cheek for maximum RF energy coupling. The “test device reference point” is aligned to the “ear reference point” on the head phantom and the “vertical centerline” is aligned to the “phantom reference plane”. This is called the “initial ear position”. While maintaining these three alignments, the body of the handset is gradually adjusted to each of the following positions for evaluating SAR:

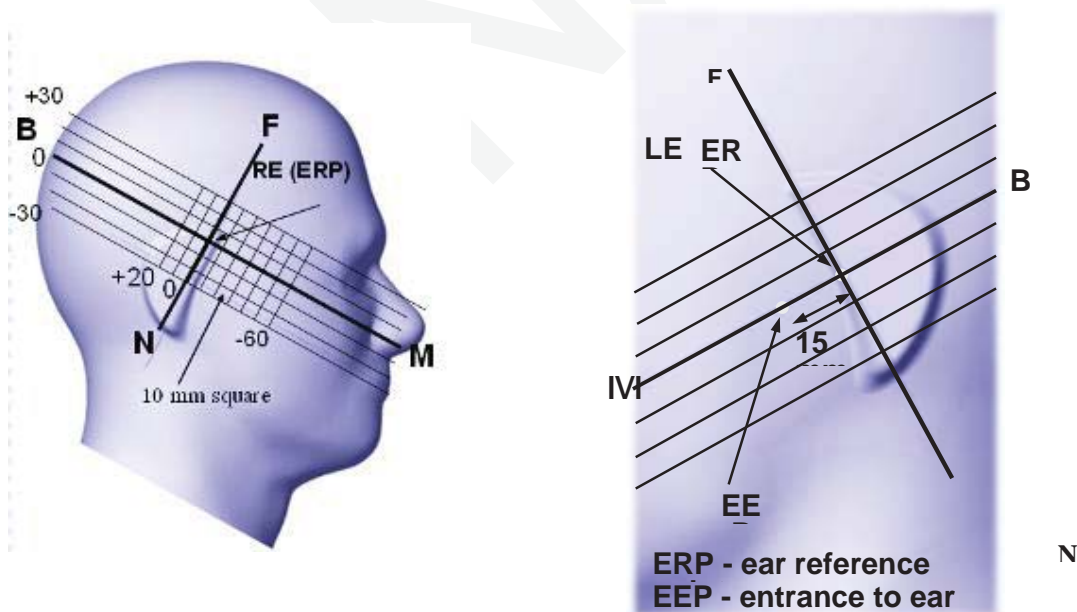

## Cheek/Touch Position

The device is brought toward the mouth of the head phantom by pivoting against the “ear reference point” or along the “N-F” line for the SCC-34/SC-2 head phantom.

This test position is established:

When any point on the display, keypad or mouthpiece portions of the handset is in contact with the phantom.

(or) When any portion of a foldout, sliding or similar keypad cover opened to its intended self-adjusting normal use position is in contact with the cheek or mouth of the phantom.

For existing head phantoms – when the handset loses contact with the phantom at the pivoting point, rotation should continue until the device touches the cheek of the phantom or breaks its last contact from the ear spacer.

### Cheek /Touch Position

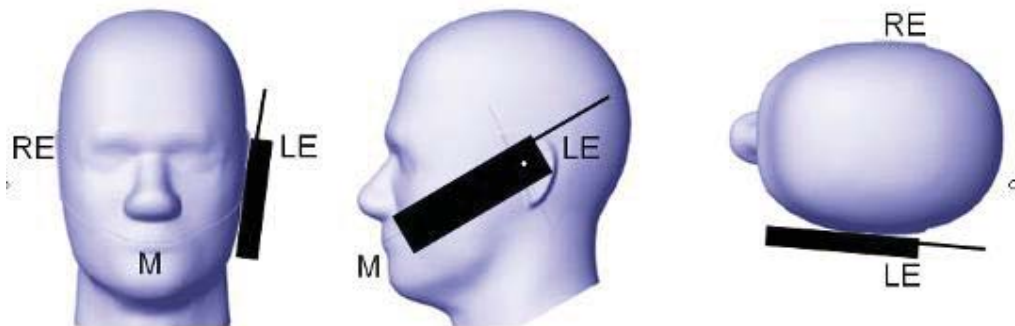

## Ear/Tilt Position

With the handset aligned in the “Cheek/Touch Position”:

1) If the earpiece of the handset is not in full contact with the phantom’s ear spacer (in the “Cheek/Touch position”) and the peak SAR location for the “Cheek/Touch” position is located at the ear spacer region or corresponds to the earpiece region of the handset, the device should be returned to the “initial ear position” by rotating it away from the mouth until the earpiece is in full contact with the ear spacer.

2) (otherwise) The handset should be moved (translated) away from the cheek perpendicular to the line passes through both “ear reference points” (note: one of these ear reference points may not physically exist on a split head model) for approximate 2-3 cm. While it is in this position, the device handset is tilted away from the mouth with respect to the “test device reference point” until the inside angle between the vertical centerline on the front surface of the phone and the horizontal line passing through the ear reference point is by 15 80°. After the tilt, it is then moved (translated) back toward the head perpendicular to the line passes through both “ear reference points” until the device touches the phantom or the ear spacer. If the antenna touches the head first, the positioning process should be repeated with a tilt angle less than 15° so that the device and its antenna would touch the phantom simultaneously. This test position may require a device holder or positioner to achieve the translation and tilting with acceptable positioning repeatability.

If a device is also designed to transmit with its keypad cover closed for operating in the head position, such positions should also be considered in the SAR evaluation. The device should be tested on the left and right side of the head phantom in the “Cheek/Touch” and “Ear/Tilt” positions. When applicable, each configuration should be tested with the antenna in its fully extended and fully retracted positions. These test configurations should be tested at the high, middle and low frequency channels of each operating mode; for example, AMPS, CDMA, and TDMA. If the SAR measured at the middle channel for each test configuration (left, right, Cheek/Touch, Tilt/Ear, extended and retracted) is at least 2.0 dB lower than the SAR limit, testing at the high and low channels is optional for such test configuration(s). If the transmission band of the test device is less than 10 MHz, testing at the high and low frequency channels is optional.

**Ear /Tilt 15° Position**

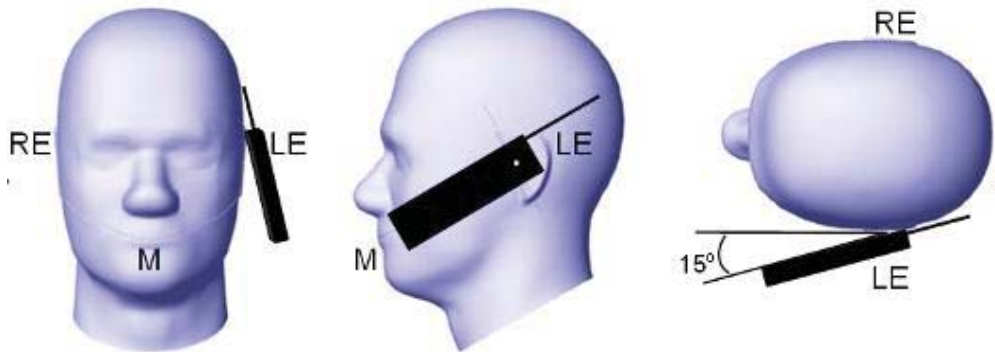

**Test positions for body-worn and other configurations**

Body-worn operating configurations should be tested with the belt-clips and holsters attached to the device and positioned against a flat phantom in normal use configurations. Devices with a headset output should be tested with a headset connected to the device. When multiple accessories that do not contain metallic components are supplied with the device, the device may be tested with only the accessory that dictates the closest spacing to the body. When multiple accessories that contain metallic components are supplied with the device, the device must be tested with each accessory that contains a unique metallic component. If multiple accessories share an identical metallic component (e.g., the same metallic belt-clip used with different holsters with no other metallic components), only the accessory that dictates the closest spacing to the body must be tested.

Body-worn accessories may not always be supplied or available as options for some devices that are intended to be authorized for body-worn use. A separation distance of 1.5 cm between the back of the device and a flat phantom is recommended for testing body-worn SAR compliance under such circumstances. Other separation distances may be used, but they should not exceed 2.5 cm. In these cases, the device may use body-worn accessories that provide a separation distance greater than that tested for the device provided however that the accessory contains no metallic components.

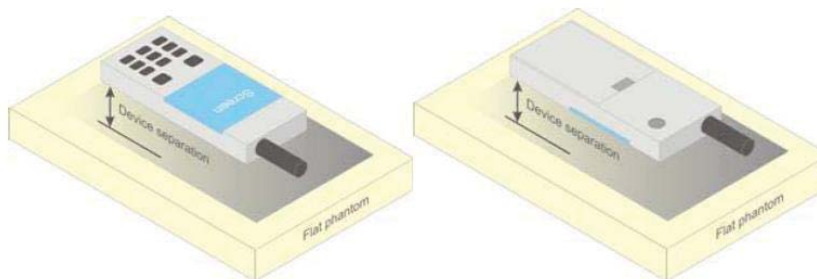

**Figure 5 – Test positions for body-worn devices**



## SAR Evaluation Procedure

The evaluation was performed with the following procedure:

Step 1: Measurement of the SAR value at a fixed location above the ear point or central position was used as a reference value for assessing the power drop. The SAR at this point is measured at the start of the test and then again at the end of the testing.

Step 2: The SAR distribution at the exposed side of the head was measured at a distance of 4 mm from the inner surface of the shell. The area covered the entire dimension of the head or EUT and the horizontal grid spacing was 10 mm x 10 mm. Based on these data, the area of the maximum absorption was determined by spline interpolation. The first Area Scan covers the entire dimension of the EUT to ensure that the hotspot was correctly identified.

Step 3: Around this point, a volume of 35 mm x 35 mm x 35 mm was assessed by measuring 7x 7 x 7 points. On the basis of this data set, the spatial peak SAR value was evaluated under the following procedure:

- 1) The data at the surface were extrapolated, since the center of the dipoles is 1.2 mm away from the tip of the probe and the distance between the surface and the lowest measuring point is 1.3 mm. The extrapolation was based on a least square algorithm. A polynomial of the fourth order was calculated through the points in z-axes. This polynomial was then used to evaluate the points between the surface and the probe tip.
- 2) The maximum interpolated value was searched with a straightforward algorithm. Around this maximum the SAR values averaged over the spatial volumes (1 g or 10 g) were computed by the 3D-Spline interpolation algorithm. The 3D-Spline is composed of three one dimensional splines with the "Not a knot"-condition (in x, y and z-directions). The volume was integrated with the trapezoidal-algorithm. One thousand points (10 x 10 x 10) were interpolated to calculate the averages.

All neighboring volumes were evaluated until no neighboring volume with a higher average value was found.

Step 4: Re-measurement of the SAR value at the same location as in Step 1. If the value changed by more than 5%, the evaluation was repeated.

## Test methodology

KDB 447498 D01 General RF Exposure Guidance v05r02.  
KDB 648474 D04 Handset SAR v01r02.  
KDB 865664 D01 SAR measurement 100 MHz to 6 GHz v01r03  
KDB 865664 D02 RF Exposure Reporting v01r01  
KDB 941225 D01 3G SAR Procedures v03  
KDB 941225 D05 SAR for LTE Devices v02r03  
KDB 941225 D06 Hotspot Mode v02



## CONDUCTED OUTPUT POWER MEASUREMENT

### Provision Applicable

The measured peak output power should be greater and within 5% than EMI measurement.

### Test Procedure

The RF output of the transmitter was connected to the input of the EMI Test Receiver through sufficient attenuation.

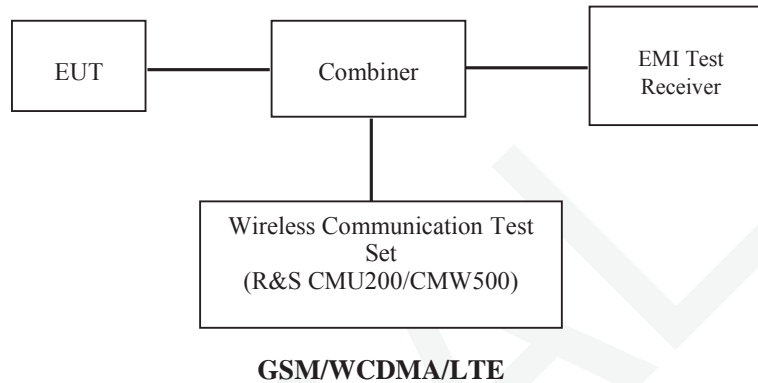

### Radio Configuration

The power measurement was configured by the Wireless Communication Test Set CMU200 for all Radio configurations except the HSPA+/DC-HSDPA configured by E5515C.

### GSM

Function: Menu select > GSM Mobile Station > GSM 850/1900

Press Connection control to choose the different menus

Press RESET > choose all the reset all settings

Connection: Press Signal Off to turn off the signal and change settings

Network Support > GSM + only

MS Signal

> 33 dBm for GSM 850

> 30 dBm for PCS 1900

BS Signal: Enter the same channel number for TCH channel (test channel) and BCCH channel

Frequency Offset >+ 0 Hz

Mode > BCCH and TCH

BCCH Level > -85 dBm (May need to adjust if link is not stable)

BCCH Channel > choose desired test channel [Enter the same channel number for TCH channel (test channel) and BCCH channel]

Channel Type > Off

P0 > 4 dB

TCH > choose desired test channel

Hopping > Off

AF/RF: Enter appropriate offsets for Ext. Att. Output and Ext. Att. Input

Connection: Press Signal on to turn on the signal and change settings

**GPRS**

Function: Menu select > GSM Mobile Station > GSM 850/1900  
 Press Connection control to choose the different menus  
 Press RESET > choose all the reset all settings  
 Connection: Press Signal Off to turn off the signal and change settings  
 Network Support > GSM + GPRS or GSM + EGSM  
 Main Service > Packet Data

Service selection > Test Mode A – Auto Slot Config. off  
 MS Signal: Press Slot Config Bottom on the right twice to select and change the number of time slots and power setting

- > Slot configuration > Uplink/Gamma
- > 33 dBm for GPRS 850
- > 30 dBm for GPRS 1900

BS Signal: Enter the same channel number for TCH channel (test channel) and BCCH channel  
 Frequency Offset >+ 0 Hz  
 Mode > BCCH and TCH  
 BCCH Level > -85 dBm (May need to adjust if link is not stable)  
 BCCH Channel > choose desired test channel [Enter the same channel number for TCH channel (test channel) and BCCH channel]

Channel Type > Off  
 P0 > 4 dB  
 Slot Config > Unchanged (if already set under MS signal)  
 TCH > choose desired test channel  
 Hopping > Off  
 Main Timeslot > 3  
 Network: Coding Scheme > CS4 (GPRS)  
 Bit Stream > 2E9-1 PSR Bit Stream  
 AF/RF: Enter appropriate offsets for Ext. Att. Output and Ext. Att. Input  
 Connection: Press Signal on to turn on the signal and change settings

**WCDMA Release 99**

The following tests were conducted according to the test requirements outlines in section 5.2 of the 3GPP TS34.121-1 specification. The EUT has a nominal maximum output power of 24dBm (+1.7/-3.7).

<b>WCDMA General Settings</b>	Loopback Mode	Test Mode 1
	Rel99 RMC	12.2kbps RMC
	Power Control Algorithm	Algorithm2
	<b>βc / βd</b>	8/15

**HSDPA**

The following tests were conducted according to the test requirements outlines in section 5.2 of the 3GPP TS34.121-1 specification.

	Mode	HSDPA	HSDPA	HSDPA	HSDPA
	Subset	1	2	3	4
WCDMA General Settings	Loopback Mode	Test Mode 1			
	Rel99 RMC	12.2kbps RMC			
	HSDPA FRC	H-Set1			
	Power Control Algorithm	Algorithm2			
	$\beta_c$	2/15	12/15	15/15	15/15
	$\beta_d$	15/15	15/15	8/15	4/15
	$\beta_d$ (SF)	64			
	$\beta_c / \beta_d$	2/15	12/15	15/8	15/4
	$\beta_{hs}$	4/15	24/15	30/15	30/15
MPR(dB)	0	0	0.5	0.5	
HSDPA Specific Settings	DACK	8			
	DNAK	8			
	DCQI	8			
	Ack-Nack repetition factor	3			
	CQI Feedback	4ms			
	CQI Repetition Factor	2			
$A_{hs} = \beta_{hs} / \beta_c$	30/15				

**HSUPA**

The following tests were conducted according to the test requirements outlines in section 5.2 of the 3GPP TS34.121-1 specification.

	Mode	HSUPA	HSUPA	HSUPA	HSUPA	HSUPA
	Subset	1	2	3	4	5
<b>WCDMA A General Settings</b>	Loopback Mode	Test Mode 1				
	Rel99 RMC	12.2kbps RMC				
	HSDPA FRC	H-Set1				
	HSUPA Test	HSUPA Loopback				
	Power Control Algorithm	Algorithm2				
	$\beta_c$	11/15	6/15	15/15	2/15	15/15
	$\beta_d$	15/15	15/15	9/15	15/15	0
	$\beta_{ec}$	209/225	12/15	30/15	2/15	5/15
	$\beta_c / \beta_d$	11/15	6/15	15/9	2/15	-
	$\beta_{hs}$	22/15	12/15	30/15	4/15	5/15
	CM(dB)	1.0	3.0	2.0	3.0	1.0
MPR(dB)	0	2	1	2	0	
<b>HSDPA Specific Settings</b>	DACK	8				
	DNAK	8				
	DCQI	8				
	Ack-Nack repetition factor	3				
	CQI Feedback	4ms				
	CQI Repetition Factor	2				
	$A_{hs} = \beta_{hs} / \beta_c$	30/15				
<b>HSUPA Specific Settings</b>	DE-DPCCH	6	8	8	5	7
	DHARQ	0	0	0	0	0
	AG Index	20	12	15	17	21
	ETFCI	75	67	92	71	81
	Associated Max UL Data Rate kbps	242.1	174.9	482.8	205.8	308.9
	Reference E_FCI	E-TFCI 11 E E-TFCI PO 4 E-TFCI 67 E-TFCI PO 18 E-TFCI 71 E-TFCI PO23 E-TFCI 75 E-TFCI PO26 E-TFCI 81 E-TFCI PO 27	E-TFCI 11 E-TFCI PO4 E-TFCI 92 E-TFCI PO 18	E-TFCI 11 E E-TFCI PO 4 E-TFCI 67 E-TFCI PO 18 E-TFCI 71 E-TFCI PO23 E-TFCI 75 E-TFCI PO26 E-TFCI 81 E-TFCI PO 27		

**HSPA+**

The following tests were conducted according to the test requirements in Table C.11.1.4 of 3GPP TS 34.121-1

Sub-test	$\beta_c$ (Note3)	$\beta_d$	$\beta_{HS}$ (Note1)	$\beta_{ec}$	$\beta_{ed}$ (2xSF2) (Note 4)	$\beta_{ed}$ (2xSF4) (Note 4)	CM (dB) (Note 2)	MPR (dB) (Note 2)	AG Index (Note 4)	E-TFCI (Note 5)	E-TFCI (boost)
1	1	0	30/15	30/15	$\beta_{ed1}$ : 30/15 $\beta_{ed2}$ : 30/15	$\beta_{ed3}$ : 24/15 $\beta_{ed4}$ : 24/15	3.5	2.5	14	105	105

Note 1:  $\Delta_{ACK}, \Delta_{NACK}$  and  $\Delta_{CQI} = 30/15$  with  $\beta_{hs} = 30/15 * \beta_c$ .

Note 2: CM = 3.5 and the MPR is based on the relative CM difference, MPR = MAX(CM-1,0).

Note 3: DPDCH is not configured, therefore the  $\beta_c$  is set to 1 and  $\beta_d = 0$  by default.

Note 4:  $\beta_{ed}$  can not be set directly; it is set by Absolute Grant Value.

Note 5: All the sub-tests require the UE to transmit 2SF2+2SF4 16QAM EDCH and they apply for UE using E-DPDCH category 7. E-DCH TTI is set to 2ms TTI and E-DCH table index = 2. To support these E-DCH configurations DPDCH is not allocated. The UE is signalled to use the extrapolation algorithm.

**DC-HSDPA**

The following tests were conducted according to the test requirements in Table Table C.8.1.12 of 3GPP TS 34.121-1

**Table C.8.1.12: Fixed Reference Channel H-Set 12**

Parameter	Unit	Value
Nominal Avg. Inf. Bit Rate	kbps	60
Inter-TTI Distance	TTI's	1
Number of HARQ Processes	Processes	6
Information Bit Payload ( $N_{INF}$ )	Bits	120
Number Code Blocks	Blocks	1
Binary Channel Bits Per TTI	Bits	960
Total Available SML's in UE	SML's	19200
Number of SML's per HARQ Proc.	SML's	3200
Coding Rate		0.15
Number of Physical Channel Codes	Codes	1
Modulation		QPSK
<p>Note 1: The RMC is intended to be used for DC-HSDPA mode and both cells shall transmit with identical parameters as listed in the table.</p> <p>Note 2: Maximum number of transmission is limited to 1, i.e., retransmission is not allowed. The redundancy and constellation version 0 shall be used.</p>		

**LTE**

For UE Power Class 1 and 3, the allowed Maximum Power Reduction (MPR) for the maximum output power in Table 6.2.2-1 due to higher order modulation and transmit bandwidth configuration (resource blocks) is specified in Table 6.2.3-1.

**Table 6.2.3-1: Maximum Power Reduction (MPR) for Power Class 1 and 3**

Modulation	Channel bandwidth / Transmission bandwidth ( $N_{RB}$ )						MPR (dB)
	1.4 MHz	3.0 MHz	5 MHz	10 MHz	15 MHz	20 MHz	
QPSK	> 5	> 4	> 8	> 12	> 16	> 18	≤ 1
16 QAM	≤ 5	≤ 4	≤ 8	≤ 12	≤ 16	≤ 18	≤ 1
16 QAM	> 5	> 4	> 8	> 12	> 16	> 18	≤ 2

For UE Power Class 1 and 3 the specific requirements and identified subclauses are specified in Table 6.2.4-1 along with the allowed A-MPR values that may be used to meet these requirements. The allowed A-MPR values specified below in Table 6.2.4.-1 to 6.2.4-15 are in addition to the allowed MPR requirements specified in subclause 6.2.3.

**Table 6.2.4-1: Additional Maximum Power Reduction (A-MPR)**

Network Signalling value	Requirements (subclause)	E-UTRA Band	Channel bandwidth (MHz)	Resources Blocks ( $N_{RB}$ )	A-MPR (dB)
NS_01	6.6.2.1.1	Table 5.5-1	1.4, 3, 5, 10, 15, 20	Table 5.6-1	N/A
NS_03	6.6.2.2.1	2, 4, 10, 23, 25, 35, 36	3	>5	≤ 1
			5	>6	≤ 1
			10	>6	≤ 1
			15	>8	≤ 1
			20	>10	≤ 1
NS_04	6.6.2.2.2	41	5	>6	≤ 1
			10, 15, 20	Table 6.2.4-4	
NS_05	6.6.3.3.1	1	10, 15, 20	≥ 50	≤ 1
NS_06	6.6.2.2.3	12, 13, 14, 17	1.4, 3, 5, 10	Table 5.6-1	N/A
NS_07	6.6.2.2.3	13	10	Table 6.2.4-2	
	6.6.3.3.2				
NS_08	6.6.3.3.3	19	10, 15	> 44	≤ 3
				> 40	≤ 1
				> 55	≤ 2
NS_10		20	15, 20	Table 6.2.4-3	
NS_11	6.6.2.2.1	23	1.4, 3, 5, 10, 15, 20	Table 6.2.4-5	
NS_12	6.6.3.3.5	26	1.4, 3, 5	Table 6.2.4-6	
NS_13	6.6.3.3.6	26	5	Table 6.2.4-7	
NS_14	6.6.3.3.7	26	10, 15	Table 6.2.4-8	
NS_15	6.6.3.3.8	26	1.4, 3, 5, 10, 15	Table 6.2.4-9	
				Table 6.2.4-10	
NS_16	6.6.3.3.9	27	3, 5, 10	Table 6.2.4-11, Table 6.2.4-12, Table 6.2.4-13	
NS_17	6.6.3.3.10	28	5, 10	Table 5.6-1	N/A
NS_18	6.6.3.3.11	28	5	≥ 2	≤ 1
			10, 15, 20	≥ 1	≤ 4
NS_19	6.6.3.3.12	44	10, 15, 20	Table 6.2.4-14	
NS_20	6.2.2	23	5, 10, 15, 20	Table 6.2.4-15	
	6.6.2.2.1				
	6.6.3.2				
...					
NS_32	-	-	-	-	-

**Maximum Target Output Power**

<b>Max Target Power(dBm)</b>			
<b>Mode/Band</b>	<b>Channel</b>		
	<b>Low</b>	<b>Middle</b>	<b>High</b>
GSM 850	33.1	33.1	33.1
GPRS 1 TX Slot	33.6	33.6	33.6
GPRS 2 TX Slot	32.8	32.8	32.8
GPRS 3 TX Slot	31.2	31.2	31.2
GPRS 4 TX Slot	29.8	29.8	29.8
EDGE 1 TX Slot	27.1	27.1	27.1
EDGE 2 TX Slot	26.1	26.1	26.1
EDGE 3 TX Slot	23.9	23.9	23.9
EDGE 4 TX Slot	23.1	23.1	23.1
PCS 1900	29.7	29.7	29.7
GPRS 1 TX Slot	29.8	29.8	29.8
GPRS 2 TX Slot	29	29	29
GPRS 3 TX Slot	26.3	26.3	26.3
GPRS 4 TX Slot	25.8	25.8	25.8
EDGE 1 TX Slot	25.4	25.4	25.4
EDGE 2 TX Slot	23.9	23.9	23.9
EDGE 3 TX Slot	22.6	22.6	22.6
EDGE 4 TX Slot	21.4	21.4	21.4
WCDMA Band 5	22.4	22.4	22.4
HSDPA	22.4	22.4	22.4
HSUPA	22.3	22.3	22.3
DC-HSDPA	22.4	22.4	22.4
HSPA+	21.4	21.4	21.4
WCDMA Band 4	22.9	22.9	22.9
HSDPA	22.4	22.4	22.4
HSUPA	22.3	22.3	22.3
DC-HSDPA	22	22	22
HSPA+	22	22	22
WCDMA Band 2	22.5	22.5	22.5
HSDPA	22.5	22.5	22.5
HSUPA	22.2	22.2	22.2
DC-HSDPA	22.1	22.1	22.1
HSPA+	20.9	20.9	20.9
LTE Band 2	23.2	23.2	23.2
LTE Band 4	22.9	22.9	22.9
LTE Band 7	23	23	23
LTE Band 17	23	23	23
WLAN	9.4	9.4	9.4
Bluetooth BDR/EDR	3.2	3.2	3.2
Bluetooth LE	-3.2	-3.2	-3.2

**Test Results:**

**GSM:**

Band	Channel No.	Frequency (MHz)	RF Output Power (dBm)
GSM 850	128	824.2	32.74
	190	836.6	32.82
	251	848.8	<b>32.97</b>
PCS 1900	512	1850.2	29.31
	661	1880	29.44
	810	1909.8	<b>29.55</b>

**GPRS:**

Band	Channel No.	Frequency (MHz)	RF Output Power (dBm)			
			1 slot	2 slots	3 slots	4 slots
GSM 850	128	824.2	33.25	32.49	31.02	29.57
	190	836.6	33.3	32.61	30.94	29.71
	251	848.8	33.48	32.73	31.11	29.63
PCS 1900	512	1850.2	29.25	28.35	26.12	25.27
	661	1880	29.28	28.5	26.23	25.31
	810	1909.8	29.65	28.86	26.06	25.68

**EGPRS:**

Band	Channel No.	Frequency (MHz)	RF Output Power (dBm)			
			1 slot	2 slots	3 slots	4 slots
GSM 850	128	824.2	26.94	25.8	23.52	22.64
	190	836.6	26.95	25.77	23.84	22.98
	251	848.8	26.97	25.98	23.25	22.95
PCS 1900	512	1850.2	25.04	23.11	22.24	21.14
	661	1880	25.14	23.36	22.35	21.32
	810	1909.8	25.25	23.75	22.48	20.94

For SAR, the time based average power is relevant, the difference in between depends on the duty cycle of the TDMA signal.

Number of Time slot	1	2	3	4
Duty Cycle	1:8	1:4	1:2.66	1:2
Time based Ave. power compared to slotted Ave. power	-9 dB	-6 dB	-4.25 dB	-3 dB
Crest Factor	8	4	2.66	2



**The time based average power for GPRS**

Band	Channel No.	Frequency (MHz)	Time based average Power (dBm)			
			1 slot	2 slot	3 slots	4 slots
GSM 850	128	824.2	24.25	26.49	26.77	26.57
	190	836.6	24.3	26.61	26.69	26.71
	251	848.8	24.48	26.73	<b>26.86</b>	26.63
PCS 1900	512	1850.2	20.25	22.35	21.87	22.27
	661	1880	20.28	22.5	21.98	22.31
	810	1909.8	20.65	<b>22.86</b>	21.81	22.68

**The time based average power for EGPRS**

Band	Channel No.	Frequency (MHz)	Time based average Power (dBm)			
			1 slot	2 slot	3 slots	4 slots
GSM 850	128	824.2	17.94	19.8	19.27	19.64
	190	836.6	17.95	19.77	19.59	19.98
	251	848.8	17.97	19.98	19	19.95
PCS 1900	512	1850.2	16.04	17.11	17.99	18.14
	661	1880	16.14	17.36	18.1	18.32
	810	1909.8	16.25	17.75	18.23	17.94

**Note:**

1. Rohde & Schwarz Radio Communication Tester (CMU200) was used for the measurement of GSM peak and average output power for active timeslots.
2. For GSM voice, 1 timeslot has been activated with power level 5 (850 MHz band) and 0 (1900 MHz band).
3. For GPRS, 1, 2, 3 and 4 timeslots has been activated separately with power level 3(850 MHz band) and 3(1900 MHz band).
4. According to KDB941225D06-SAR for EGPRS mode are not required when the source-based time-averaged output power for data mode is lower than that in the normal GPRS mode

**WCDMA:  
Results (12.2kbps RMC)**

Band	Frequency (MHz)	RF Output Power (dBm)
WCDMA Band 5	826.4	22.26
	836.6	22.24
	846.6	21.97
WCDMA Band 4	1712.4	22.84
	1732.6	21.75
	1752.6	22.08
WCDMA Band 2	1852.4	22.08
	1880	22.35
	1907.6	21.98

**Results (HSDPA)**

Band	Frequency (MHz)	RF Output Power (dBm)			
		Subset 1	Subset 2	Subset 3	Subset 4
WCDMA Band 5	826.4	22.31	22.13	22.22	21.99
	836.6	22.23	22.16	22.15	21.86
	846.6	21.79	21.85	21.73	21.85
WCDMA Band 4	1712.4	22.25	22.34	22.22	22.16
	1732.6	20.86	20.92	20.93	20.87
	1752.6	21.72	21.65	21.62	21.6
WCDMA Band 2	1852.4	22.32	22.16	22.1	22.05
	1880	22.39	22.27	22.13	22.06
	1907.6	21.85	21.92	21.85	21.64

**Results (HSUPA)**

Band	Frequency (MHz)	RF Output Power (dBm)				
		Subset 1	Subset 2	Subset 3	Subset 4	Subset 5
WCDMA Band 5	826.4	22.21	22.13	21.99	22.05	21.91
	836.6	22.22	21.53	22.15	22.18	21.99
	846.6	21.72	21.76	21.95	21.93	21.91
WCDMA Band 4	1712.4	21.82	22.21	21.83	21.37	21.89
	1732.6	20.89	20.83	20.86	20.83	20.84
	1752.6	21.59	21.54	21.59	21.57	21.46
WCDMA Band 2	1852.4	22.09	21.98	21.95	21.89	21.76
	1880	22.01	22.07	21.98	21.87	21.73
	1907.6	21.83	21.75	21.59	21.53	21.47

**Results (DC-HSDPA):**

Band	Frequency (MHz)	RF Output Power (dBm)			
		Subset 1	Subset 2	Subset 3	Subset 4
WCDMA Band 5	826.4	22.16	22.21	22.06	22.09
	836.6	21.94	21.89	21.87	21.89
	846.6	22.13	22.23	22.18	22.32
WCDMA Band 4	1712.4	21.68	21.86	21.62	21.89
	1732.6	20.82	20.81	20.79	20.82
	1752.6	21.43	21.47	21.45	21.41
WCDMA Band 2	1852.4	21.48	21.63	21.33	21.32
	1880	21.71	21.66	21.61	21.53
	1907.6	21.52	21.58	21.96	21.82

**Results (HSPA+)**

Band	Frequency (MHz)	RF Output Power (dBm)
WCDMA Band 5	826.4	21.32
	836.6	20.97
	846.6	21.16
WCDMA Band 4	1712.4	21.88
	1732.6	20.71
	1752.6	21.38
WCDMA Band 2	1852.4	20.48
	1880	20.77
	1907.6	20.34

**Note:**

1. The default test configuration is to measure SAR with an established radio link between the EUT and a communication test set using a 12.2 kbps RMC (reference measurement Channel) Configured in Test Loop Model 1.
2. KDB 941225 D01-Body SAR is not required for HSDPA/HSUPA/HSPA+/DC-HSDPA when the maximum average output of each RF channel is less than ¼ dB higher than measured 12.2kbps RMC or the maximum SAR for 12.2kbps RMC is < 75% of SAR limit.

LTE Band 2:

Test Bandwidth	Test Modulation	Resource Block & RB offset	Low Channel (dBm)	Middle Channel (dBm)	High Channel (dBm)
1.4M	QPSK	1#0	22.80	22.89	22.55
		1#3	22.99	<b>23.15</b>	22.76
		1#5	22.89	22.96	22.66
		3#0	22.25	22.34	22.02
		3#1	22.17	22.22	21.94
		3#3	22.20	22.38	22.05
		6#0	21.69	21.98	21.70
	16-QAM	1#0	22.26	22.48	22.02
		1#3	22.29	22.56	22.27
		1#5	22.15	22.38	22.01
		3#0	21.58	21.60	21.22
		3#1	21.35	21.53	21.13
		3#3	21.32	21.58	21.39
		6#0	20.92	21.07	20.78
3M	QPSK	1#0	22.80	23.00	22.48
		1#7	22.95	22.98	22.63
		1#14	22.92	22.91	22.65
		8#0	22.34	22.57	22.03
		8#4	22.48	22.63	22.39
		8#7	22.33	22.49	22.25
		15#0	22.02	22.02	21.77
	16-QAM	1#0	22.50	22.54	22.21
		1#7	22.52	22.63	22.32
		1#14	22.33	22.55	22.17
		8#0	21.06	21.16	20.89
		8#4	21.31	21.44	21.19
		8#7	20.98	21.20	21.05
		15#0	20.98	21.08	20.83
5M	QPSK	1#0	22.82	23.02	22.80
		1#12	22.91	23.05	22.84
		1#24	22.85	23.08	22.70
		12#0	22.29	22.40	22.11
		12#6	22.24	22.49	22.14
		12#11	22.23	22.37	22.02
		25#0	21.83	21.87	21.67
	16-QAM	1#0	22.36	22.48	22.19
		1#12	22.46	22.56	22.18
		1#24	22.34	22.54	22.20
		12#0	21.37	21.60	21.39
		12#6	21.61	21.69	21.48
		12#11	21.46	21.76	21.49
		25#0	20.82	20.93	20.67
10M	QPSK	1#0	22.48	22.78	22.29
		1#24	22.61	22.92	22.46
		1#49	22.54	22.79	22.58

			25#0	22.08	22.19	21.90		
			25#12	22.11	22.28	21.87		
			25#24	22.13	22.21	21.85		
			50#0	21.70	21.93	21.50		
			16-QAM	1#0	22.12	22.13	21.98	
				1#24	22.13	22.28	21.85	
				1#49	22.13	22.17	21.85	
				25#0	21.32	21.55	21.28	
				25#12	21.37	21.58	21.20	
				25#24	21.32	21.56	21.22	
				50#0	20.78	20.92	20.70	
			15M	QPSK	1#0	22.99	23.02	22.71
					1#37	22.91	23.12	22.82
					1#74	22.79	23.03	22.65
36#0	22.22	22.32			22.05			
36#17	22.29	22.43			22.10			
36#35	22.15	22.40			22.01			
75#0	21.52	21.72			21.46			
16-QAM	1#0	22.12		22.28	22.19			
	1#37	22.16		22.33	22.10			
	1#74	22.22		22.34	21.94			
	36#0	21.27		21.53	21.24			
	36#17	21.35		21.59	21.25			
	36#35	21.28		21.33	21.12			
	75#0	20.65		21.03	20.66			
20M	QPSK	1#0	22.69	22.78	22.43			
		1#49	22.50	22.70	22.45			
		1#99	22.70	22.84	22.48			
		50#0	21.82	22.11	21.76			
		50#24	21.91	22.01	21.78			
		50#49	21.85	22.10	21.80			
		100#0	21.37	21.74	21.30			
	16-QAM	1#0	21.81	22.01	21.58			
		1#49	22.02	22.05	21.96			
		1#99	21.84	21.99	21.86			
		50#0	21.07	21.38	21.00			
		50#24	21.21	21.22	20.97			
		50#49	21.05	21.30	20.91			
		100#0	20.65	20.74	20.47			

**LTE Band 4:**

Test Bandwidth	Test Modulation	Resource Block & RB offset	Low Channel (dBm)	Middle Channel (dBm)	High Channel (dBm)
1.4M	QPSK	1#0	22.80	22.62	22.35
		1#3	22.61	22.30	22.14
		1#5	22.71	22.45	22.25
		3#0	22.75	22.41	22.24
		3#1	22.42	22.32	22.25

	16-QAM	3#3	22.61	22.52	22.32	
		6#0	21.81	21.41	21.24	
		1#0	21.82	21.52	21.34	
		1#3	21.72	21.52	21.22	
		1#5	21.81	21.60	21.48	
		3#0	21.73	21.59	21.35	
		3#1	21.68	21.51	21.24	
		3#3	21.72	21.69	21.56	
		6#0	20.90	20.56	20.50	
	3M	QPSK	1#0	22.70	22.35	22.09
			1#7	22.39	22.17	21.99
			1#14	22.53	22.27	22.04
			8#0	22.37	22.08	21.95
			8#4	22.37	22.04	21.86
			8#7	22.35	22.03	21.96
		15#0	21.62	21.33	21.35	
		16-QAM	1#0	22.15	21.94	21.73
			1#7	22.07	21.87	21.75
1#14			22.09	21.95	21.67	
8#0			21.60	21.46	21.13	
8#4			21.51	21.27	21.12	
8#7			21.46	21.34	21.15	
15#0		20.67	20.64	20.32		
5M		QPSK	1#0	22.67	22.38	22.39
			1#12	22.62	22.41	22.20
			1#24	22.73	22.63	22.44
			12#0	22.00	21.90	21.92
	12#6		22.15	21.87	21.74	
	12#11		22.25	21.96	21.90	
	25#0	21.59	21.39	21.28		
	16-QAM	1#0	21.74	21.54	21.29	
		1#12	21.45	21.39	21.15	
		1#24	21.68	21.50	21.20	
		12#0	21.16	21.16	21.15	
		12#6	21.28	21.11	20.83	
		12#11	21.29	21.15	20.97	
	25#0	20.82	20.74	20.49		
	10M	QPSK	1#0	22.10	22.01	22.03
			1#24	22.17	22.10	21.90
			1#49	22.42	22.19	22.01
			25#0	21.84	21.66	21.48
25#12			21.98	21.78	21.49	
25#24			22.12	21.80	21.74	
50#0		21.40	21.14	21.04		
16-QAM		1#0	21.63	21.46	21.43	
		1#24	21.52	21.40	21.28	
		1#49	21.71	21.45	21.34	
		25#0	21.05	20.96	20.85	
		25#12	21.05	20.92	20.78	
		25#24	21.24	21.08	20.93	

15M	QPSK	50#0	20.51	20.31	20.09
		1#0	22.11	22.02	21.71
		1#37	22.15	22.01	21.78
		1#74	21.98	21.86	21.85
		36#0	21.76	21.52	21.42
		36#17	21.68	21.57	21.27
		36#35	21.71	21.57	21.43
	16-QAM	75#0	21.16	20.98	20.80
		1#0	21.58	21.25	21.02
		1#37	21.46	21.15	21.07
		1#74	21.52	21.39	21.16
		36#0	21.00	20.89	20.72
		36#17	20.90	20.79	20.61
		36#35	21.09	21.01	20.76
20M	QPSK	75#0	20.25	20.06	19.87
		1#0	22.81	22.63	22.36
		1#49	22.65	22.30	22.16
		1#99	22.72	22.55	22.24
		50#0	22.70	22.45	22.24
		50#24	22.47	22.35	22.23
		50#49	22.67	22.53	22.36
	16-QAM	100#0	21.82	21.49	21.29
		1#0	21.23	21.07	20.68
		1#49	21.31	21.23	21.13
		1#99	21.21	21.13	20.87
		50#0	20.81	20.71	20.48
		50#24	21.84	21.56	21.27
		50#49	21.72	21.54	21.44
100#0	20.04	19.80	19.61		

LTE Band 7:

Test Bandwidth	Test Modulation	Resource Block & RB offset	Low Channel (dBm)	Middle Channel (dBm)	High Channel (dBm)
5M	QPSK	1#0	22.54	22.88	22.34
		1#12	22.60	22.83	22.46
		1#24	22.42	22.79	22.13
		12#0	21.94	22.13	21.77
		12#6	21.87	22.31	21.62
		12#11	22.01	22.14	21.71
		25#0	21.42	21.69	21.31
	16-QAM	1#0	21.44	21.65	21.21
		1#12	21.32	21.67	21.24
		1#24	21.41	21.66	21.36
		12#0	21.13	21.05	20.59
		12#6	20.88	21.20	20.55
		12#11	20.99	21.27	20.75
		25#0	20.51	20.95	20.34

10M	QPSK	1#0	22.62	22.78	22.37
		1#24	22.80	<b>22.94</b>	22.42
		1#49	22.40	22.92	22.27
		25#0	21.93	22.04	21.49
		25#12	22.00	22.16	21.68
		25#24	21.99	22.10	21.54
		50#0	21.76	21.73	21.57
	16-QAM	1#0	21.93	22.25	21.75
		1#24	21.80	22.15	21.72
		1#49	21.82	22.02	21.70
		25#0	21.02	21.30	20.87
		25#12	21.09	21.33	20.82
		25#24	21.13	21.40	21.11
		50#0	20.53	20.91	20.46
15M	QPSK	1#0	22.57	22.87	22.57
		1#37	22.66	22.89	22.46
		1#74	22.68	22.98	22.29
		36#0	21.76	22.06	21.70
		36#17	21.82	22.13	21.39
		36#35	21.85	22.10	21.62
		75#0	21.61	21.78	21.34
	16-QAM	1#0	22.13	22.21	21.74
		1#37	22.05	22.40	21.90
		1#74	21.87	22.17	21.83
		36#0	21.15	21.44	21.14
		36#17	21.41	21.51	21.17
		36#35	21.23	21.42	20.83
		75#0	20.74	20.90	20.47
20M	QPSK	1#0	22.46	22.76	22.23
		1#49	22.79	22.83	22.44
		1#99	22.69	22.86	22.25
		50#0	21.70	21.77	21.20
		50#24	21.57	21.80	21.22
		50#49	21.58	21.83	21.43
		100#0	21.74	21.79	21.45
	16-QAM	1#0	21.86	21.93	21.49
		1#49	21.93	22.15	21.78
		1#99	21.70	22.05	21.74
		50#0	21.09	21.42	20.85
		50#24	21.26	21.37	20.78
		50#49	21.10	21.29	20.85
		100#0	20.53	20.84	20.36



**LTE Band 17:**

Test Bandwidth	Test Modulation	Resource Block & RB offset	Low Channel (dBm)	Middle Channel (dBm)	High Channel (dBm)
5M	QPSK	1#0	22.49	22.78	22.29
		1#12	22.58	22.68	22.38
		1#24	22.67	22.79	22.45
		12#0	21.92	22.21	21.98
		12#6	21.90	22.21	21.91
		12#11	21.93	22.05	21.83
		25#0	21.32	21.68	21.33
	16-QAM	1#0	21.64	21.80	21.46
		1#12	21.46	21.73	21.38
		1#24	21.47	21.71	21.49
		12#0	20.75	21.14	20.89
		12#6	20.91	21.15	20.77
		12#11	20.81	20.93	20.81
		25#0	20.52	20.80	20.59
10M	QPSK	1#0	22.55	<b>22.84</b>	22.50
		1#24	22.54	22.76	22.52
		1#49	22.73	22.86	22.55
		25#0	21.82	21.98	21.69
		25#12	22.04	22.08	21.80
		25#24	21.83	22.00	21.80
		50#0	21.50	21.74	21.49
	16-QAM	1#0	21.77	22.12	21.74
		1#24	21.72	21.92	21.65
		1#49	21.82	21.98	21.57
		25#0	21.26	21.54	21.28
		25#12	21.44	21.58	21.25
		25#24	21.18	21.45	21.11
		50#0	20.77	21.00	20.54

**Note:**

- 1.SAR for LTE band exposure configurations is measured according to the procedures of KDB 941225 D05 SAR for LTE Devices v02.
- 2.The CMW500 Wideband Radio Communication tester is used for LTE output power measurements and SAR testing. Closed loop power control is used to keep the radio transmitters the max output power during the test.
- 3.KDB941225D05v02- SAR for higher order modulation is required only when the highest maximum output power for the configuration in the higher order modulation is > ½ dB higher than the same configuration in QPSK or when the reported SAR for the QPSK configuration is > 1.45 W/kg

**Bluetooth**

Mode	Channel No.	Channel frequency (MHz)	RF Output Power (dBm)
BDR(GFSK)	0	2402	3.02
	39	2441	1.9
	78	2480	<b>3.1</b>
EDR(4-DQPSK)	0	2402	1.95
	39	2441	1.27
	78	2480	2.03
EDR(8-DPSK)	0	2402	2.34
	39	2441	1.41
	78	2480	2.63
Bluetooth LE	0	2402	-5.2
	19	2440	<b>-3.28</b>
	39	2480	-3.49

**WLAN**

Mode	Channel No.	Channel frequency (MHz)	RF Output Power (dBm)
<b>802.11b</b>	1	2412	9.11
	6	2437	9.08
	11	2462	9.24
802.11g	1	2412	9.28
	6	2437	<b>9.37</b>
	11	2462	9.15
802.11n HT20	1	2412	9.10
	6	2437	9.04
	11	2462	9.24
802.11n HT40	3	2422	9.03
	6	2437	9.03
	9	2452	9.09

**Note:**

The output power was tested under data rate 1Mbps for 802.11b, 6Mbps for 802.11g, 6.5Mbps for 802.11n HT20, 13.5Mbps for 802.11n HT40.

## SAR MEASUREMENT RESULTS

This page summarizes the results of the performed dosimetric evaluation.

The EUT is capable of function as a WLAN to cellular mobile hotspot. Additional SAR test was performed according to KDB941225 D06. Test was performed with a separation of 1cm between the EUT and the flat phantom. The EUT was positioned for SAR tests with the front and back surfaces facing the edge. Each transmit band was utilized for SAR testing. The tested mode has been selected within each band that exhibits the highest time average output power.

### SAR Test Data

#### Environmental Conditions

<b>Temperature:</b>	24-24.6 °C	22.5-23.5 °C	22.5-23.5 °C
<b>Relative Humidity:</b>	32-33 %	30-31 %	30 %
<b>ATM Pressure:</b>	1001 mbar	1003 mbar	1003 mbar
<b>Record Date:</b>	2015-09-07	2015-09-08	2015-09-09

*Testing was performed by Rocky Xiao*

**GSM 850:**

EUT Position	Frequency (MHz)	Test Mode	Power Drift (dB)	Max. Meas. Power (dBm)	Max. Rated Power (dBm)	1g SAR (W/Kg)			
						Scaled Factor	Meas. SAR	Scaled SAR	Plot
Left Head Cheek	824.2	GSM	-0.02	32.74	33.1	1.086	0.0513	0.056	/
	836.6	GSM	0.05	32.82	33.1	1.067	0.051	0.054	/
	848.8	GSM	0.06	32.97	33.1	1.03	0.059	0.061	1#
Left Head Tilt	824.2	GSM	/	/	/	/	/	/	/
	836.6	GSM	0.07	32.82	33.1	1.067	0.031	0.033	/
	848.8	GSM	/	/	/	/	/	/	/
Right Head Cheek	824.2	GSM	/	/	/	/	/	/	/
	836.6	GSM	0.16	32.82	33.1	1.067	0.0492	0.052	/
	848.8	GSM	/	/	/	/	/	/	/
Right Head Tilt	824.2	GSM	/	/	/	/	/	/	/
	836.6	GSM	0	32.82	33.1	1.067	0.031	0.033	/
	848.8	GSM	/	/	/	/	/	/	/
Body-Back-Headset (10mm)	824.2	GSM	/	/	/	/	/	/	/
	836.6	GSM	0.04	32.82	33.1	1.067	0.412	0.44	/
	848.8	GSM	/	/	/	/	/	/	/
Body-Back (10mm)	824.2	GPRS	0.1	31.02	31.2	1.042	0.453	0.472	/
	836.6	GPRS	0.04	30.94	31.2	1.062	0.442	0.469	/
	848.8	GPRS	0.09	31.11	31.2	1.021	0.469	0.479	2#
Body-Left (10mm)	824.2	GPRS	/	/	/	/	/	/	/
	836.6	GPRS	-0.1	30.94	31.2	1.062	0.101	0.107	/
	848.8	GPRS	/	/	/	/	/	/	/
Body-Right (10mm)	824.2	GPRS	/	/	/	/	/	/	/
	836.6	GPRS	-0.04	30.94	31.2	1.062	0.162	0.172	/
	848.8	GPRS	/	/	/	/	/	/	/
Body-Bottom (10mm)	824.2	GPRS	/	/	/	/	/	/	/
	836.6	GPRS	0.12	30.94	31.2	1.062	0.253	0.269	/
	848.8	GPRS	/	/	/	/	/	/	/

**Note:**

1. When the 1-g SAR is  $\leq 0.8W/Kg$ , testing for other channels are optional.
2. The EUT transmit and receive through the same GSM antenna while testing SAR.
3. When SAR or MPE is not measured at the maximum power level allowed for production units, the results must be scaled to the maximum tune-up tolerance limit according to the power applied to the individual channels tested to determine compliance.
4. When the maximum output power variation across the required test channels is  $> \frac{1}{2}$  dB, instead of the middle channel, the highest output power channel must be used.
5. The Multi-slot Classes of EUT is Class 12 which has maximum 4 Downlink slots and 4 Uplink slots, the maximum active slots is 5, when perform the multiple slots scan, 2DL+3UL is the worst case.

**PCS Band:**

EUT Position	Frequency (MHz)	Test Mode	Power Drift (dB)	Max. Meas. Power (dBm)	Max. Rated Power (dBm)	1g SAR (W/Kg)			
						Scaled Factor	Meas. SAR	Scaled SAR	Plot
Left Head Cheek	1850.2	GSM	/	/	/	/	/	/	/
	1880	GSM	-0.17	29.44	29.7	1.062	0.127	0.135	/
	1909.8	GSM	/	/	/	/	/	/	/
Left Head Tilt	1850.2	GSM	/	/	/	/	/	/	/
	1880	GSM	-0.17	29.44	29.7	1.062	0.0872	0.093	/
	1909.8	GSM	/	/	/	/	/	/	/
Right Head Cheek	1850.2	GSM	-0.02	29.31	29.7	1.094	0.129	0.141	/
	1880	GSM	-0.02	29.44	29.7	1.062	0.133	0.141	/
	1909.8	GSM	0.11	29.55	29.7	1.035	0.142	0.147	3#
Right Head Tilt	1850.2	GSM	/	/	/	/	/	/	/
	1880	GSM	-0.16	29.44	29.7	1.062	0.0779	0.083	/
	1909.8	GSM	/	/	/	/	/	/	/
Body-Back-Headset (10mm)	1850.2	GSM	0.12	29.31	29.7	1.094	0.96	1.05	/
	1880	GSM	-0.15	29.44	29.7	1.062	0.963	1.023	/
	1909.8	GSM	-0.1	29.55	29.7	1.035	0.988	1.023	/
Body-Back (10mm)	1850.2	GPRS	0.02	28.35	29	1.161	0.716	0.831	/
	1880.0	GPRS	-0.11	28.5	29	1.122	0.772	0.866	/
	1909.8	GPRS	0.13	28.86	29	1.033	0.788	0.814	/
Body-Left (10mm)	1850.2	GPRS	/	/	/	/	/	/	/
	1880.0	GPRS	-0.03	28.5	29	1.122	0.364	0.408	/
	1909.8	GPRS	/	/	/	/	/	/	/
Body-Right (10mm)	1850.2	GPRS	/	/	/	/	/	/	/
	1880.0	GPRS	-0.1	28.5	29	1.122	0.471	0.528	/
	1909.8	GPRS	/	/	/	/	/	/	/
Body-Bottom (10mm)	1850.2	GPRS	-0.05	28.35	29	1.161	1.03	1.196	/
	1880.0	GPRS	-0.07	28.5	29	1.122	1.09	1.223	/
	1909.8	GPRS	-0.02	28.86	29	1.033	1.21	1.25	4#

**Note:**

1. When the 1-g SAR is  $\leq 0.8W/Kg$ , testing for other channels are optional.
2. The EUT transmit and receive through the same GSM antenna while testing SAR.
3. When SAR or MPE is not measured at the maximum power level allowed for production units, the results must be scaled to the maximum tune-up tolerance limit according to the power applied to the individual channels tested to determine compliance.
4. When the maximum output power variation across the required test channels is  $> \frac{1}{2}$  dB, instead of the middle channel, the highest output power channel must be used.
5. The Multi-slot Classes of EUT is Class 12 which has maximum 4 Downlink slots and 4 Uplink slots, the maximum active slots is 5, when perform the multiple slots scan, 3DL+2UL is the worst case.

**WCDMA 850 Band:**

EUT Position	Frequency (MHz)	Test Mode	Power Drift (dB)	Max. Meas. Power (dBm)	Max. Rated Power (dBm)	1g SAR (W/Kg)			
						Scaled Factor	Meas. SAR	Scaled SAR	Plot
Left Head Cheek	826.4	WCDMA	-0.15	22.26	22.4	1.033	0.0451	0.047	/
	836.6	WCDMA	0.16	22.24	22.4	1.038	0.0453	0.047	/
	846.6	WCDMA	-0.17	21.97	22.4	1.104	0.044	0.049	5#
Left Head Tilt	826.4	WCDMA	-0.11	22.26	22.4	1.033	0.0215	0.022	/
	836.6	WCDMA	/	/	/	/	/	/	/
	846.6	WCDMA	/	/	/	/	/	/	/
Right Head Cheek	826.4	WCDMA	0.02	22.26	22.4	1.033	0.0412	0.043	/
	836.6	WCDMA	/	/	/	/	/	/	/
	846.6	WCDMA	/	/	/	/	/	/	/
Right Head Tilt	826.4	WCDMA	-0.05	22.26	22.4	1.033	0.02	0.021	/
	836.6	WCDMA	/	/	/	/	/	/	/
	846.6	WCDMA	/	/	/	/	/	/	/
Body-Back (10mm)	826.4	WCDMA	0.06	22.26	22.4	1.033	0.285	0.294	/
	836.6	WCDMA	0.07	22.24	22.4	1.038	0.281	0.292	/
	846.6	WCDMA	0.04	21.97	22.4	1.104	0.273	0.301	6#
Body-Left (10mm)	826.4	WCDMA	0.07	22.26	22.4	1.033	0.072	0.074	/
	836.6	WCDMA	/	/	/	/	/	/	/
	846.6	WCDMA	/	/	/	/	/	/	/
Body-Right (10mm)	826.4	WCDMA	-0.02	22.26	22.4	1.033	0.121	0.125	/
	836.6	WCDMA	/	/	/	/	/	/	/
	846.6	WCDMA	/	/	/	/	/	/	/
Body-Bottom (10mm)	826.4	WCDMA	0.11	22.26	22.4	1.033	0.182	0.188	/
	836.6	WCDMA	/	/	/	/	/	/	/
	846.6	WCDMA	/	/	/	/	/	/	/

**Note:**

1. When the 1-g SAR is  $\leq 0.8W/Kg$ , testing for other channels are optional.
2. The EUT transmit and receive through the same antenna while testing SAR.
3. The default test configuration is to measure SAR with an established radio link between the EUT and a communication test set using a 12.2 kbps RMC (reference measurement Channel) Configured in Test Loop Model.
4. KDB 941225 D01-Body SAR is not required for HSDPA/HSUPA/HSPA+/DC-HSDPA when the maximum average output of each RF channel is less than  $\frac{1}{4}$  dB higher than measured 12.2kbps RMC or the maximum SAR for 12.2kbps RMC is  $< 75\%$  of SAR limit.
5. When SAR or MPE is not measured at the maximum power level allowed for production units, the results must be scaled to the maximum tune-up tolerance limit according to the power applied to the individual channels tested to determine compliance.

**WCDMA 1750 Band:**

EUT Position	Frequency (MHz)	Test Mode	Power Drift (dB)	Max. Meas. Power (dBm)	Max. Rated Power (dBm)	1g SAR (W/Kg)			
						Scaled Factor	Meas. SAR	Scaled SAR	Plot
Left Head Cheek	1712.4	WCDMA	0.17	22.84	22.9	1.014	0.336	0.341	/
	1732.6	WCDMA	/	/	/	/	/	/	/
	1752.6	WCDMA	/	/	/	/	/	/	/
Left Head Tilt	1712.4	WCDMA	0.15	22.84	22.9	1.014	0.179	0.182	/
	1732.6	WCDMA	/	/	/	/	/	/	/
	1752.6	WCDMA	/	/	/	/	/	/	/
Right Head Cheek	1712.4	WCDMA	0.01	22.84	22.9	1.014	0.352	0.357	/
	1732.6	WCDMA	0.15	21.75	22.9	1.303	0.277	0.361	/
	1752.6	WCDMA	0.16	22.08	22.9	1.208	0.308	0.372	7#
Right Head Tilt	1712.4	WCDMA	0.09	22.84	22.9	1.014	0.17	0.172	/
	1732.6	WCDMA	/	/	/	/	/	/	/
	1752.6	WCDMA	/	/	/	/	/	/	/
Body-Back (10mm)	1712.4	WCDMA	-0.08	22.84	22.9	1.014	0.953	0.966	/
	1732.6	WCDMA	0.02	21.75	22.9	1.303	0.742	0.967	/
	1752.6	WCDMA	0.04	22.08	22.9	1.208	0.752	0.908	/
Body-Left (10mm)	1712.4	WCDMA	-0.09	22.84	22.9	1.014	0.388	0.393	/
	1732.6	WCDMA	/	/	/	/	/	/	/
	1752.6	WCDMA	/	/	/	/	/	/	/
Body-Right (10mm)	1712.4	WCDMA	-0.07	22.84	22.9	1.014	0.402	0.408	/
	1732.6	WCDMA	/	/	/	/	/	/	/
	1752.6	WCDMA	/	/	/	/	/	/	/
Body-Bottom (10mm)	1712.4	WCDMA	-0.01	22.84	22.9	1.014	1.21	1.227	/
	1732.6	WCDMA	0.02	21.75	22.9	1.303	0.951	1.239	/
	1752.6	WCDMA	-0.13	22.08	22.9	1.208	1.08	1.305	8#

**Note:**

1. When the 1-g SAR is  $\leq 0.8W/Kg$ , testing for other channels are optional.
2. The EUT transmit and receive through the same antenna while testing SAR.
3. The default test configuration is to measure SAR with an established radio link between the EUT and a communication test set using a 12.2 kbps RMC (reference measurement Channel) Configured in Test Loop Model.
4. KDB 941225 D01-Body SAR is not required for HSDPA/HSUPA/HSPA+/DC-HSDPA when the maximum average output of each RF channel is less than 1/4 dB higher than measured 12.2kbps RMC or the maximum SAR for 12.2kbps RMC is < 75% of SAR limit.
5. When SAR or MPE is not measured at the maximum power level allowed for production units, the results must be scaled to the maximum tune-up tolerance limit according to the power applied to the individual channels tested to determine compliance.

**WCDMA 1900 Band:**

EUT Position	Frequency (MHz)	Test Mode	Power Drift (dB)	Max. Meas. Power (dBm)	Max. Rated Power (dBm)	1g SAR (W/Kg)			
						Scaled Factor	Meas. SAR	Scaled SAR	Plot
Left Head Cheek	1852.4	WCDMA	/	/	/	/	/	/	/
	1880	WCDMA	-0.16	22.35	22.5	1.035	0.228	0.236	/
	1907.6	WCDMA	/	/	/	/	/	/	/
Left Head Tilt	1852.4	WCDMA	/	/	/	/	/	/	/
	1880	WCDMA	-0.1	22.35	22.5	1.035	0.139	0.144	/
	1907.6	WCDMA	/	/	/	/	/	/	/
Right Head Cheek	1852.4	WCDMA	0.16	22.08	22.5	1.102	0.221	0.244	/
	1880	WCDMA	-0.01	22.35	22.5	1.035	0.241	0.249	<b>9#</b>
	1907.6	WCDMA	-0.04	21.98	22.5	1.127	0.206	0.232	/
Right Head Tilt	1852.4	WCDMA	/	/	/	/	/	/	/
	1880	WCDMA	-0.14	22.35	22.5	1.035	0.131	0.136	/
	1907.6	WCDMA	/	/	/	/	/	/	/
Body-Back (10mm)	1852.4	WCDMA	-0.14	22.08	22.5	1.102	0.739	0.814	/
	1880.0	WCDMA	-0.07	22.35	22.5	1.035	0.776	0.803	/
	1907.6	WCDMA	0.04	21.98	22.5	1.127	0.717	0.808	/
Body-Left (10mm)	1852.4	WCDMA	/	/	/	/	/	/	/
	1880.0	WCDMA	-0.09	22.35	22.5	1.035	0.442	0.457	/
	1907.6	WCDMA	/	/	/	/	/	/	/
Body-Right (10mm)	1852.4	WCDMA	/	/	/	/	/	/	/
	1880.0	WCDMA	-0.13	22.35	22.5	1.035	0.327	0.338	/
	1907.6	WCDMA	/	/	/	/	/	/	/
Body-Bottom (10mm)	1852.4	WCDMA	-0.11	22.08	22.5	1.102	1.07	1.179	/
	1880.0	WCDMA	0.07	22.35	22.5	1.035	1.22	1.263	<b>10#</b>
	1907.6	WCDMA	-0.1	21.98	22.5	1.127	0.996	1.122	/

**Note:**

1. When the 1-g SAR is  $\leq 0.8W/Kg$ , testing for other channels are optional.
2. The EUT transmit and receive through the same antenna while testing SAR.
3. The default test configuration is to measure SAR with an established radio link between the EUT and a communication test set using a 12.2 kbps RMC (reference measurement Channel) Configured in Test Loop Model.
4. KDB 941225 D01-Body SAR is not required for HSDPA/HSUPA/HSPA+/DC-HSDPA when the maximum average output of each RF channel is less than 1/4 dB higher than measured 12.2kbps RMC or the maximum SAR for 12.2kbps RMC is < 75% of SAR limit.
5. When SAR or MPE is not measured at the maximum power level allowed for production units, the results must be scaled to the maximum tune-up tolerance limit according to the power applied to the individual channels tested to determine compliance.



**LTE Band 2:**

EUT Position	Frequency (MHz)	Bandwidth (MHz)	Test Mode	Power Drift (dB)	Max. Meas. Power (dBm)	Max. Rated Power (dBm)	1g SAR (W/Kg)			
							Scaled Factor	Meas. SAR	Scaled SAR	Plot
Left Head Cheek	1860	20	1RB	/	/	/	/	/	/	/
	1880	20	1RB	0.04	22.84	23.2	1.086	0.0916	0.099	/
	1900	20	1RB	/	/	/	/	/	/	/
	1880	20	50%RB	-0.08	22.11	23.2	1.285	0.0703	0.09	/
Left Head Tilt	1860	20	1RB	/	/	/	/	/	/	/
	1880	20	1RB	0.11	22.84	23.2	1.086	0.0615	0.067	/
	1900	20	1RB	/	/	/	/	/	/	/
	1880	20	50%RB	-0.04	22.11	23.2	1.285	0.0512	0.066	/
Right Head Cheek	1860	20	1RB	-0.09	22.7	23.2	1.122	0.0864	0.097	/
	1880	20	1RB	0.15	22.84	23.2	1.086	0.112	0.122	<b>11#</b>
	1900	20	1RB	-0.06	22.48	23.2	1.18	0.0826	0.097	/
	1880	20	50%RB	-0.06	22.11	23.2	1.285	0.0856	0.11	/
Right Head Tilt	1860	20	1RB	/	/	/	/	/	/	/
	1880	20	1RB	-0.17	22.84	23.2	1.086	0.0544	0.059	/
	1900	20	1RB	/	/	/	/	/	/	/
	1880	20	50%RB	-0.08	22.11	23.2	1.285	0.044	0.057	/
Body-Back (10mm)	1860	20	1RB	/	/	/	/	/	/	/
	1880	20	1RB	0.17	22.84	23.2	1.086	0.664	0.721	/
	1900	20	1RB	/	/	/	/	/	/	/
	1880	20	50%RB	-0.17	22.11	23.2	1.285	0.526	0.676	/
Body-Left (10mm)	1860	20	1RB	/	/	/	/	/	/	/
	1880	20	1RB	0.03	22.84	23.2	1.086	0.189	0.205	/
	1900	20	1RB	/	/	/	/	/	/	/
	1880	20	50%RB	-0.01	22.11	23.2	1.285	0.154	0.198	/
Body-Right (10mm)	1860	20	1RB	/	/	/	/	/	/	/
	1880	20	1RB	0.12	22.84	23.2	1.086	0.328	0.356	/
	1900	20	1RB	/	/	/	/	/	/	/
	1880	20	50%RB	0.06	22.11	23.2	1.285	0.276	0.355	/
Body-Bottom (10mm)	1860	20	1RB	0.16	22.7	23.2	1.122	0.912	1.023	/
	1880	20	1RB	-0.11	22.84	23.2	1.086	1.11	1.205	<b>12#</b>
	1900	20	1RB	0.11	22.48	23.2	1.18	0.823	0.971	/
	1880	20	50%RB	-0.05	22.11	23.2	1.285	0.776	0.997	/

**LTE Band 4:**

EUT Position	Frequency (MHz)	Bandwidth (MHz)	Test Mode	Power Drift (dB)	Max. Meas. Power (dBm)	Max. Rated Power (dBm)	1g SAR (W/Kg)			
							Scaled Factor	Meas. SAR	Scaled SAR	Plot
Left Head Cheek	1720	20	1RB	0.13	22.81	22.9	1.021	0.0912	0.095	/
	1732.5	20	1RB	/	/	/	/	/	/	/
	1745	20	1RB	/	/	/	/	/	/	/
	1720	20	50%RB	0.1	22.7	22.9	1.047	0.0856	0.092	
Left Head Tilt	1720	20	1RB	0.01	22.81	22.9	1.021	0.0523	0.055	/
	1732.5	20	1RB	/	/	/	/	/	/	/
	1745	20	1RB	/	/	/	/	/	/	/
	1720	20	50%RB	0.14	22.7	22.9	1.047	0.0493	0.053	
Right Head Cheek	1720	20	1RB	-0.06	22.81	22.9	1.021	0.097	0.101	<b>13#</b>
	1732.5	20	1RB	-0.1	22.63	22.9	1.064	0.086	0.094	/
	1745	20	1RB	0.03	22.36	22.9	1.132	0.0765	0.089	/
	1720	20	50%RB	-0.15	22.7	22.9	1.047	0.0812	0.087	/
Right Head Tilt	1720	20	1RB	-0.16	22.81	22.9	1.021	0.0489	0.051	/
	1732.5	20	1RB	/	/	/	/	/	/	/
	1745	20	1RB	/	/	/	/	/	/	/
	1720	20	50%RB	-0.03	22.7	22.9	1.047	0.044	0.047	/
Body-Back (10mm)	1720	20	1RB	-0.04	22.81	22.9	1.021	0.6	0.627	/
	1732.5	20	1RB	/	/	/	/	/	/	/
	1745	20	1RB	/	/	/	/	/	/	/
	1720	20	50%RB	-0.01	22.7	22.9	1.047	0.575	0.616	/
Body-Left (10mm)	1720	20	1RB	-0.16	22.81	22.9	1.021	0.149	0.156	/
	1732.5	20	1RB	/	/	/	/	/	/	/
	1745	20	1RB	/	/	/	/	/	/	/
	1720	20	50%RB	0.15	22.7	22.9	1.047	0.138	0.148	/
Body-Right (10mm)	1720	20	1RB	-0.05	22.81	22.9	1.021	0.284	0.297	/
	1732.5	20	1RB	/	/	/	/	/	/	/
	1745	20	1RB	/	/	/	/	/	/	/
	1720	20	50%RB	0.06	22.7	22.9	1.047	0.262	0.281	/
Body-Bottom (10mm)	1720	20	1RB	0.01	22.81	22.9	1.021	0.914	0.955	<b>14#</b>
	1732.5	20	1RB	0.15	22.63	22.9	1.064	0.846	0.921	/
	1745	20	1RB	0	22.36	22.9	1.132	0.801	0.928	/
	1720	20	50%RB	-0.01	22.7	22.9	1.047	0.851	0.912	/

**LTE Band 7:**

EUT Position	Frequency (MHz)	Bandwidth (MHz)	Test Mode	Power Drift (dB)	Max. Meas. Power (dBm)	Max. Rated Power (dBm)	1g SAR (W/Kg)			
							Scaled Factor	Meas. SAR	Scaled SAR	Plot
Left Head Cheek	2510	20	1RB	/	/	/	/	/	/	/
	2535	20	1RB	0.17	22.86	23	1.033	0.154	0.159	/
	2560	20	1RB	/	/	/	/	/	/	/
	2535	20	50%RB	0.06	21.8	23	1.318	0.123	0.162	/
Left Head Tilt	2510	20	1RB	/	/	/	/	/	/	/
	2535	20	1RB	-0.13	22.86	23	1.033	0.092	0.095	/
	2560	20	1RB	/	/	/	/	/	/	/
	2535	20	50%RB	0.14	21.8	23	1.318	0.07	0.092	/
Right Head Cheek	2510	20	1RB	-0.01	22.69	23	1.074	0.143	0.154	/
	2535	20	1RB	0.2	22.86	23	1.033	0.168	0.174	15#
	2560	20	1RB	-0.08	22.25	23	1.189	0.136	0.162	/
	2535	20	50%RB	0.01	21.8	23	1.318	0.117	0.154	/
Right Head Tilt	2510	20	1RB	/	/	/	/	/	/	/
	2535	20	1RB	0.17	22.86	23	1.033	0.0826	0.085	/
	2560	20	1RB	/	/	/	/	/	/	/
	2535	20	50%RB	0.08	21.8	23	1.318	0.0612	0.081	/
Body-Back (10mm)	2510	20	1RB	/	/	/	/	/	/	/
	2535	20	1RB	0.04	22.86	23	1.033	0.654	0.676	/
	2560	20	1RB	/	/	/	/	/	/	/
	2535	20	50%RB	-0.05	21.8	23	1.318	0.472	0.622	/
Body-Left (10mm)	2510	20	1RB	/	/	/	/	/	/	/
	2535	20	1RB	-0.13	22.86	23	1.033	0.206	0.213	/
	2560	20	1RB	/	/	/	/	/	/	/
	2535	20	50%RB	-0.12	21.8	23	1.318	0.163	0.215	/
Body-Right (10mm)	2510	20	1RB	/	/	/	/	/	/	/
	2535	20	1RB	0.14	22.86	23	1.033	0.218	0.225	/
	2560	20	1RB	/	/	/	/	/	/	/
	2535	20	50%RB	0	21.8	23	1.318	0.168	0.221	/
Body-Bottom (10mm)	2510	20	1RB	-0.14	22.69	23	1.074	0.866	0.93	/
	2535	20	1RB	0.03	22.86	23	1.033	1.01	1.043	16#
	2560	20	1RB	0.13	22.25	23	1.189	0.815	0.969	/
	2535	20	50%RB	0.04	21.8	23	1.318	0.743	0.979	/

**Note:**

1. When the 1-g SAR is  $\leq 0.8\text{W/Kg}$ , testing for other channels are optional.
2. SAR for LTE band exposure configurations is measured according to the procedures of KDB 941225 D05 SAR for LTE Devices v02.
3. KDB941225D05- SAR for higher order modulation is required only when the highest maximum output power for the configuration in the higher order modulation is  $> \frac{1}{2}$  dB higher than the same configuration in QPSK or when the reported SAR for the QPSK configuration is  $> 1.45\text{ W/kg}$
4. KDB941225D05- For QPSK with 100% RB allocation, when the reported SAR measured for the Highest output power channel is  $< 1.45\text{ W/kg}$ , tests for the remaining required test channels are optional.
5. KDB941225D05- For QPSK with 100% RB allocation, SAR is not required when the highest maximum output power for 100 % RB allocation is less than the highest maximum output power in 50% and 1 RB allocations and the highest reported SAR for 1 RB and 50% RB allocation are  $\leq 0.8\text{ W/kg}$ .
6. KDB941225D05- Start with the largest channel bandwidth and measure SAR for QPSK with 1 RB allocation, using the RB offset and required test channel combination with the highest maximum output power among RB offset the upper edge, middle and lower edge of each required test channel.
7. KDB941225D05- other channel bandwidths SAR test is required when the highest maximum output power of a configuration requiring testing in the smaller channel bandwidth is  $> \frac{1}{2}$  dB higher than the equivalent channel configurations in the largest channel bandwidth configuration or the reported SAR of a configuration for the largest channel bandwidth is  $> 1.45\text{ W/kg}$ .
8. Worst case SAR for 50% RB allocation is selected to be tested.

## SAR SIMULTANEOUS TRANSMISSION DESCRIPTION

### BT& WLAN and GSM&3G&4G Antennas Location:

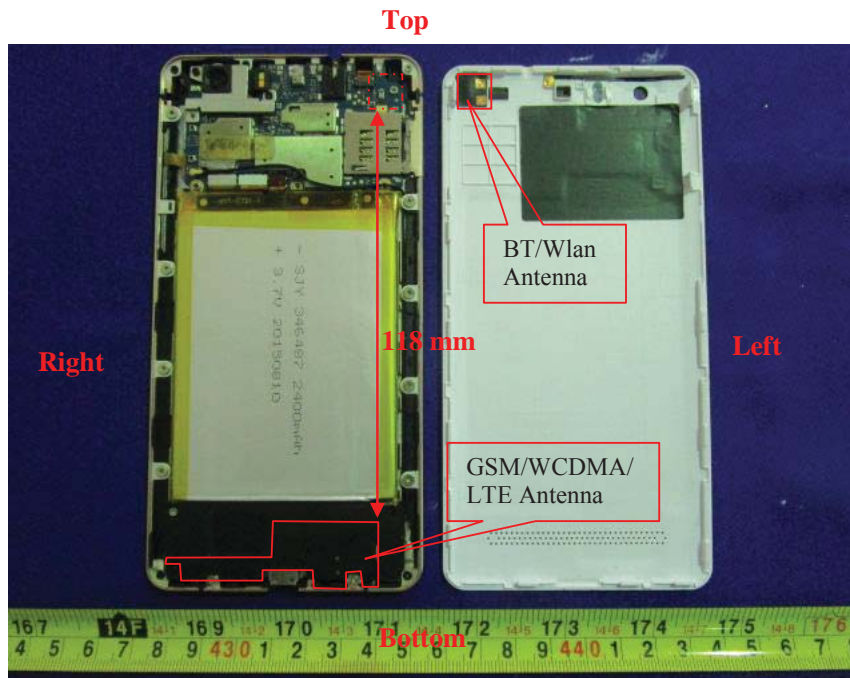

### Simultaneous Transmission:

Description of Simultaneous Transmit Capabilities			Antennas Distance (mm)
Transmitter Combination	Simultaneous?	Hotspot?	
GSM + WCDMA	×	×	0
GSM+LTE	×	×	0
GSM + Bluetooth	√	×	118
GSM + WLAN	√	√	118
WCDMA+LTE	×	×	0
WCDMA + Bluetooth	√	×	118
WCDMA + WLAN	√	√	118
LTE + Bluetooth	√	×	118
LTE + WLAN	√	√	118

**Standalone SAR test exclusion considerations**

Mode	Frequency (MHz)	Pavg (dBm)	Pavg (mW)	Distance (mm)	Calculated value	Threshold (1-g)	SAR Test Exclusion
WLAN	2462	9.4	8.71	0	2.7	3	YES
Bluetooth	2480	3.2	2.09	0	0.7	3	YES

**NOTE:**

The 1-g and 10-g SAR test exclusion thresholds for 100 MHz to 6 GHz at test separation distances ≤ 50 mm are determined by:

$$\left[ \frac{\text{max. power of channel, including tune-up tolerance, mW}}{\text{min. test separation distance, mm}} \right] \cdot \sqrt{f(\text{GHz})} \leq 3.0 \text{ for 1-g SAR and } \leq 7.5 \text{ for 10-g extremity SAR, where}$$

1. f(GHz) is the RF channel transmit frequency in GHz.
2. Power and distance are rounded to the nearest mW and mm before calculation.
3. The result is rounded to one decimal place for comparison.
4. When the minimum test separation distance is < 5 mm, a distance of 5 mm is applied to determine SAR test Exclusion.

**Standalone SAR estimation:**

Mode	Frequency (GHz)	Pavg (dBm)	Pavg (mW)	Distance (mm)	Estimated 1-g (W/kg)
WLAN Head	2462	9.4	8.71	0	0.364
WLAN Body	2462	9.4	8.71	10	0.181
BT Head	2480	3.2	2.09	0	0.087
BT Body	2480	3.2	2.09	10	0.044

When standalone SAR test exclusion applies to an antenna that transmits simultaneously with other antennas, the standalone SAR must be estimated according to following to determine simultaneous transmission SAR test exclusion:

$$\left[ \frac{\text{max. power of channel, including tune-up tolerance, mW}}{\text{min. test separation distance, mm}} \right] \cdot \sqrt{f(\text{GHz})/x}$$

W/kg for test separation distances ≤ 50 mm;

where x = 7.5 for 1-g SAR.

When the minimum test separation distance is < 5 mm, a distance of 5 mm is applied to determine SAR test Exclusion

**Simultaneous and Hotspot SAR test exclusion considerations:**

Mode (SAR1+SAR2)	Position	Reported SAR (W/kg)		ΣSAR < 1.6W/kg
		SAR1	SAR2	
GSM 850+BT	Left Head Cheek	0.061	0.087	0.148
	Left Head Tilt	0.033	0.087	0.12
	Right Head Cheek	0.052	0.087	0.139
	Right Head Tilt	0.033	0.087	0.12
	Body-Back-Headset	0.44	0.044	0.484
	Body-Back	0.269	0.044	0.313
	Body-Left	0.107	0.044	0.151
	Body-Right	0.172	0.044	0.216
	Body-Bottom	0.479	0.044	0.523
PCS 1900+BT	Left Head Cheek	0.147	0.087	0.234
	Left Head Tilt	0.093	0.087	0.18
	Right Head Cheek	0.135	0.087	0.222
	Right Head Tilt	0.083	0.087	0.17
	Body-Back-Headset	1.023	0.044	1.067
	Body-Back	0.866	0.044	0.91
	Body-Left	0.408	0.044	0.452
	Body-Right	0.528	0.044	0.572
	Body-Bottom	1.25	0.044	1.294
GSM 850 +WLAN	Left Head Cheek	0.061	0.364	0.425
	Left Head Tilt	0.033	0.364	0.397
	Right Head Cheek	0.052	0.364	0.416
	Right Head Tilt	0.033	0.364	0.397
	Body-Back-Headset	0.44	0.181	0.621
GSM 850 +WLAN (Hotspot)	Body-Back	0.269	0.181	0.45
	Body-Left	0.107	0.181	0.288
	Body-Right	0.172	0.181	0.353
	Body-Bottom	0.479	0.181	0.66
PCS 1900 +WLAN	Left Head Cheek	0.147	0.364	0.511
	Left Head Tilt	0.093	0.364	0.457
	Right Head Cheek	0.135	0.364	0.499
	Right Head Tilt	0.083	0.364	0.447
	Body-Back-Headset	1.023	0.181	1.204
PCS 1900 +WLAN (Hotspot)	Body-Back	0.866	0.181	1.047
	Body-Left	0.408	0.181	0.589
	Body-Right	0.528	0.181	0.709
	Body-Bottom	1.25	0.181	<b>1.431</b>

Mode (SAR1+SAR2)	Position	Reported SAR (W/kg)		ΣSAR < 1.6W/kg
		SAR1	SAR2	
WCDMA 850 +BT	Left Head Cheek	0.049	0.087	0.136
	Left Head Tilt	0.022	0.087	0.109
	Right Head Cheek	0.043	0.087	0.13
	Right Head Tilt	0.021	0.087	0.108
	Body-Back	0.188	0.044	0.232
	Body-Left	0.074	0.044	0.118
	Body-Right	0.125	0.044	0.169
WCDMA 1750 +BT	Body-Bottom	0.301	0.044	0.345
	Left Head Cheek	0.372	0.087	0.459
	Left Head Tilt	0.182	0.087	0.269
	Right Head Cheek	0.341	0.087	0.428
	Right Head Tilt	0.172	0.087	0.259
	Body-Back	0.967	0.044	1.011
	Body-Left	0.393	0.044	0.437
WCDMA 1900 +BT	Body-Right	0.408	0.044	0.452
	Body-Bottom	1.305	0.044	1.349
	Left Head Cheek	0.249	0.087	0.336
	Left Head Tilt	0.144	0.087	0.231
	Right Head Cheek	0.236	0.087	0.323
	Right Head Tilt	0.136	0.087	0.223
	Body-Back	0.814	0.044	0.858
WCDMA 850 +WLAN	Body-Left	0.457	0.044	0.501
	Body-Right	0.338	0.044	0.382
	Body-Bottom	1.263	0.044	1.307
	Left Head Cheek	0.049	0.364	0.413
WCDMA 850 +WLAN(Hotspot)	Left Head Tilt	0.022	0.364	0.386
	Right Head Cheek	0.043	0.364	0.407
	Right Head Tilt	0.021	0.364	0.385
	Body-Back	0.188	0.181	0.369
WCDMA 1750 +WLAN	Body-Left	0.125	0.181	0.306
	Left Head Cheek	0.372	0.364	<b>0.736</b>
	Left Head Tilt	0.182	0.364	0.546
	Right Head Cheek	0.341	0.364	0.705
WCDMA 1750 +WLAN(Hotspot)	Right Head Tilt	0.172	0.364	0.536
	Body-Back	0.967	0.181	1.148
WCDMA 1900 +WLAN	Body-Left	0.408	0.181	0.589
	Left Head Cheek	0.249	0.364	0.613
	Left Head Tilt	0.144	0.364	0.508
	Right Head Cheek	0.236	0.364	0.6
WCDMA 1900+WLAN(Hotspot)	Right Head Tilt	0.136	0.364	0.5
	Body-Back	0.814	0.181	0.995
	Body-Left	0.338	0.181	0.519



Mode(SAR1+SAR2)	Position	Reported SAR (W/kg)		ΣSAR < 1.6W/kg
		SAR1	SAR2	
LTE Band 2+BT	Left Head Cheek	0.099	0.087	0.186
	Left Head Tilt	0.067	0.087	0.154
	Right Head Cheek	0.122	0.087	0.209
	Right Head Tilt	0.059	0.087	0.146
	Body-Back	0.721	0.044	0.765
	Body-Right	0.205	0.044	0.249
	Body-Left	0.356	0.044	0.4
	Body-Bottom	1.205	0.044	1.249
LTE Band 4+BT	Left Head Cheek	0.095	0.087	0.182
	Left Head Tilt	0.055	0.087	0.142
	Right Head Cheek	0.101	0.087	0.188
	Right Head Tilt	0.051	0.087	0.138
	Body-Back	0.627	0.044	0.671
	Body-Right	0.156	0.044	0.2
	Body-Left	0.297	0.044	0.341
	Body-Bottom	0.955	0.044	0.999
LTE Band 7+BT	Left Head Cheek	0.162	0.087	0.249
	Left Head Tilt	0.095	0.087	0.182
	Right Head Cheek	0.174	0.087	0.261
	Right Head Tilt	0.085	0.087	0.172
	Body-Back	0.676	0.044	0.72
	Body-Right	0.215	0.044	0.259
	Body-Left	0.225	0.044	0.269
	Body-Bottom	1.043	0.044	1.087
LTE Band 2 +WLAN	Left Head Cheek	0.099	0.364	0.463
	Left Head Tilt	0.067	0.364	0.431
	Right Head Cheek	0.122	0.364	0.486
	Right Head Tilt	0.059	0.364	0.423
LTE Band 2+WLAN (Hotspot)	Body-Back	0.721	0.181	0.902
	Body-Left	0.356	0.181	0.537
LTE Band 4 +WLAN	Left Head Cheek	0.095	0.364	0.459
	Left Head Tilt	0.055	0.364	0.419
	Right Head Cheek	0.101	0.364	0.465
	Right Head Tilt	0.051	0.364	0.415
LTE Band 4+WLAN(Hotspot)	Body-Back	0.627	0.181	0.808
	Body-Left	0.297	0.181	0.478
LTE Band 7 +WLAN	Left Head Cheek	0.162	0.364	0.526
	Left Head Tilt	0.095	0.364	0.459
	Right Head Cheek	0.174	0.364	0.538
	Right Head Tilt	0.085	0.364	0.449
LTE Band 4+WLAN(Hotspot)	Body-Back	0.627	0.181	0.808
	Body-Left	0.297	0.181	0.478

LTE Band 17 +WLAN	Left Head Cheek	0.057	0.087	0.137
	Left Head Tilt	0.03	0.087	0.122
	Right Head Cheek	0.054	0.044	0.087
	Right Head Tilt	0.031	0.044	0.075
LTE Band 17+WLAN (Hotspot)	Body-Back	0.374	0.044	0.382
	Body-Left	0.131	0.044	0.123

**Note:**

Hotspot mode SAR is only required for the edges within 25mm from the transmitting antenna located.

**Conclusion:**

$\Sigma$ SAR < 1.6 W/kg therefore simultaneous transmission SAR with Volume Scans is **not** required.

## SAR Plots (Summary of the Highest SAR Values)

**Test Laboratory:** Bay Area Compliance Labs Corp.(Dongguan)

**Test Plot 1#:** GSM 850 Left Cheek High Channel

**DUT:** Gravity 5.5LTE; **Type:** Gravity 5.5LTE

Communication System: Generic GSM; Frequency: 848.8 MHz;Duty Cycle: 1:8  
 Medium parameters used:  $f = 848.8 \text{ MHz}$ ;  $\sigma = 0.896 \text{ S/m}$ ;  $\epsilon_r = 42.701$ ;  $\rho = 1000 \text{ kg/m}^3$   
 Phantom section: Left Section

DASY5 Configuration:

- Probe: EX3DV4 - SN7329; ConvF(9.52, 9.52, 9.52); Calibrated: 2015/2/5;
- Sensor-Surface: 4mm (Mechanical Surface Detection)
- Electronics: DAE4 Sn1459; Calibrated: 2015/1/26
- Phantom: SAM (30deg probe tilt) with CRP v5.0\_20150321; Type: QD000P40CD; Serial: TP:1874
- Measurement SW: DASY52, Version 52.8 (8);

**Head/GSM 850 Left Cheek/Area Scan (71x111x1):** Interpolated grid:  $dx=1.500 \text{ mm}$ ,  $dy=1.500 \text{ mm}$   
 Maximum value of SAR (interpolated) = 0.0620 W/kg

**Head/GSM 850 Left Cheek/Zoom Scan (7x7x7)/Cube 0:** Measurement grid:  $dx=5\text{mm}$ ,  $dy=5\text{mm}$ ,  $dz=5\text{mm}$   
 Reference Value = 2.174 V/m; Power Drift = 0.06 dB  
 Peak SAR (extrapolated) = 0.0720 W/kg  
**SAR(1 g) = 0.059 W/kg; SAR(10 g) = 0.046 W/kg**  
 Maximum value of SAR (measured) = 0.0622 W/kg

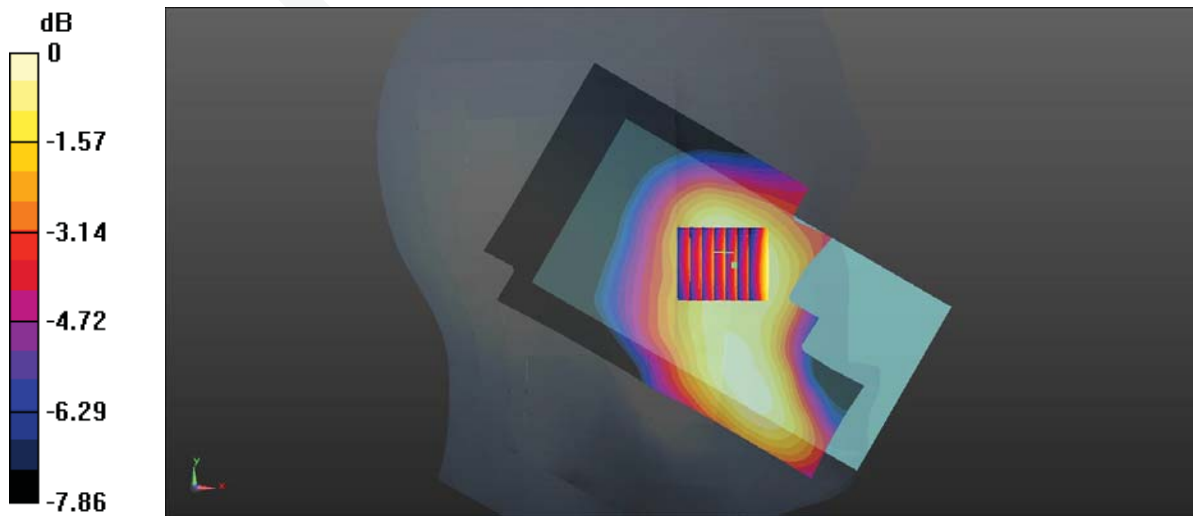

0 dB = 0.0622 W/kg = -12.06 dBW/kg

**Test Laboratory: Bay Area Compliance Labs Corp.(Dongguan)**

**Test Plot 2#:GSM 850 Back High Channel**

**DUT: Gravity 5.5LTE; Type: Gravity 5.5LTE**

Communication System: Generic GPRS-3 SLOTS; Frequency: 848.8 MHz;Duty Cycle: 1:2.67

Medium parameters used:  $f=848.8$  MHz;  $\sigma = 0.987$  S/m;  $\epsilon_r = 54.994$ ;  $\rho = 1000$  kg/m<sup>3</sup>

Phantom section: Flat Section

DASY5 Configuration:

- Probe: EX3DV4 - SN7329; ConvF(9.17, 9.17, 9.17); Calibrated: 2015/2/5;
- Sensor-Surface: 4mm (Mechanical Surface Detection)
- Electronics: DAE4 Sn1459; Calibrated: 2015/1/26
- Phantom: SAM (30deg probe tilt) with CRP v5.0\_20150321; Type: QD000P40CD; Serial: TP:1874
- Measurement SW: DASY52, Version 52.8 (8);

**Body/GSM 850 Back/Area Scan (61x111x1):** Interpolated grid: dx=1.500 mm, dy=1.500 mm

Maximum value of SAR (interpolated) = 0.507 W/kg

**Body/GSM 850 Back/Zoom Scan (7x7x7)/Cube 0:** Measurement grid: dx=5mm, dy=5mm, dz=5mm

Reference Value = 19.60 V/m; Power Drift = 0.09 dB

Peak SAR (extrapolated) = 0.624 W/kg

**SAR(1 g) = 0.469 W/kg; SAR(10 g) = 0.344 W/kg**

Maximum value of SAR (measured) = 0.498 W/kg

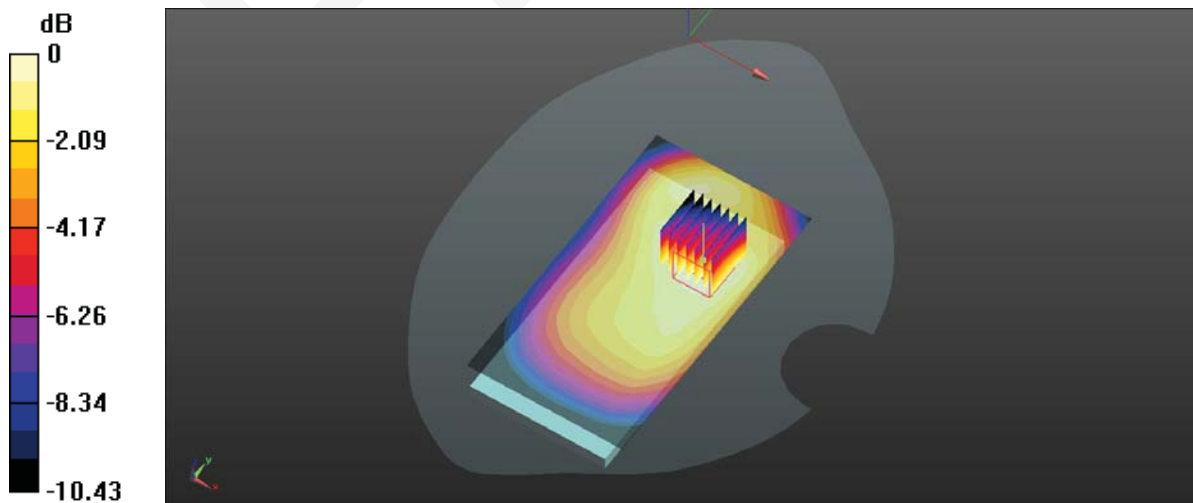

0 dB = 0.498 W/kg = -3.03 dBW/kg

**Test Laboratory: Bay Area Compliance Labs Corp.(Dongguan)**

**Test Plot 3#:PCS 1900 Right Cheek High Channel**

**DUT: Gravity 5.5LTE; Type: Gravity 5.5LTE**

Communication System: Generic GSM; Frequency: 1909.8 MHz;Duty Cycle: 1:8  
 Medium parameters used:  $f = 1909.8 \text{ MHz}$ ;  $\sigma = 1.412 \text{ S/m}$ ;  $\epsilon_r = 39.588$ ;  $\rho = 1000 \text{ kg/m}^3$   
 Phantom section: Right Section

DASY5 Configuration:

- Probe: EX3DV4 - SN7329; ConvF(8.12, 8.12, 8.12); Calibrated: 2015/2/5;
- Sensor-Surface: 4mm (Mechanical Surface Detection)
- Electronics: DAE4 Sn1459; Calibrated: 2015/1/26
- Phantom: SAM (30deg probe tilt) with CRP v5.0\_20150321; Type: QD000P40CD; Serial: TP:1874
- Measurement SW: DASY52, Version 52.8 (8);

**Head/PCS 1900 Right/Area Scan (71x121x1):** Interpolated grid: dx=1.500 mm, dy=1.500 mm

Maximum value of SAR (interpolated) = 0.161 W/kg

**Head/PCS 1900 Right/Zoom Scan (7x7x7)/Cube 0:** Measurement grid: dx=5mm, dy=5mm, dz=5mm

Reference Value = 2.522 V/m; Power Drift =0.11 dB

Peak SAR (extrapolated) = 0.217 W/kg

**SAR(1 g) = 0.142 W/kg; SAR(10 g) = 0.086 W/kg**

Maximum value of SAR (measured) = 0.155 W/kg

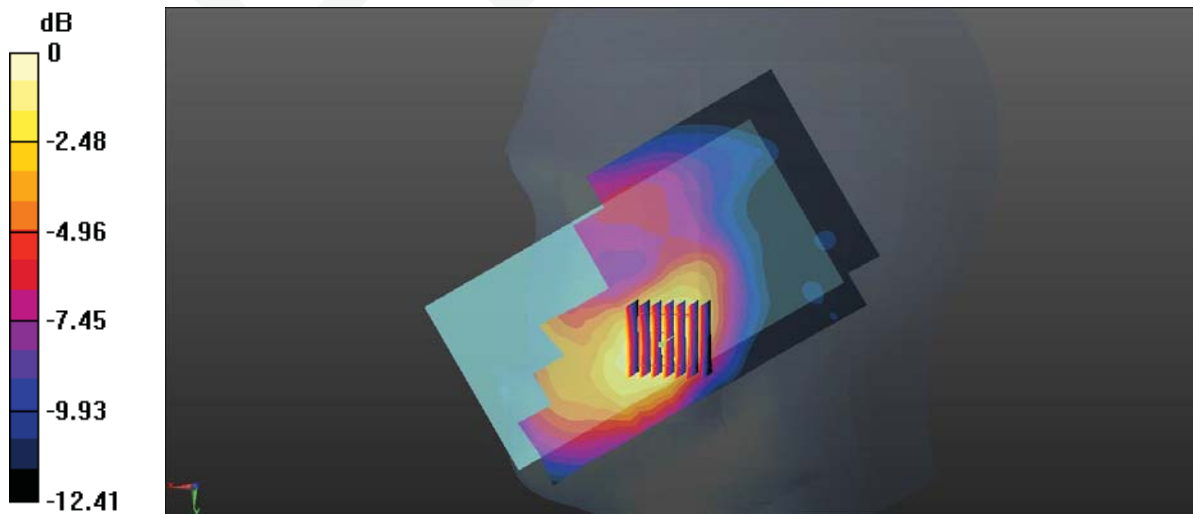

0 dB = 0.155 W/kg = -8.10 dBW/kg

**Test Laboratory: Bay Area Compliance Labs Corp.(Dongguan)**

**Test Plot 4#:PCS 1900 Bottom High Channel**

**DUT: Gravity 5.5LTE; Type: Gravity 5.5LTE**

Communication System: Generic GPRS-2 SLOTS; Frequency: 1909.8 MHz;Duty Cycle: 1: 4

Medium parameters used:  $f = 1909.8 \text{ MHz}$ ;  $\sigma = 1.491 \text{ S/m}$ ;  $\epsilon_r = 53.379$ ;  $\rho = 1000 \text{ kg/m}^3$

Phantom section: Flat Section

DASY5 Configuration:

- Probe: EX3DV4 - SN7329; ConvF(7.56, 7.56, 7.56); Calibrated: 2015/2/5;
- Sensor-Surface: 4mm (Mechanical Surface Detection)
- Electronics: DAE4 Sn1459; Calibrated: 2015/1/26
- Phantom: SAM (30deg probe tilt) with CRP v5.0\_20150321; Type: QD000P40CD; Serial: TP:1874
- Measurement SW: DASY52, Version 52.8 (8);

**Body/PCS 1900 Bottom/Area Scan (71x41x1):** Interpolated grid:  $dx=1.500 \text{ mm}$ ,  $dy=1.500 \text{ mm}$

Maximum value of SAR (interpolated) = 2.32 W/kg

**Body/PCS 1900 Bottom/Zoom Scan (7x7x7)/Cube 0:** Measurement grid:  $dx=5\text{mm}$ ,  $dy=5\text{mm}$ ,  $dz=5\text{mm}$

Reference Value = 27.07 V/m; Power Drift = -0.02 dB

Peak SAR (extrapolated) = 3.56 W/kg

**SAR(1 g) = 1.21 W/kg; SAR(10 g) = 0.655 W/kg**

Maximum value of SAR (measured) = 1.59 W/kg

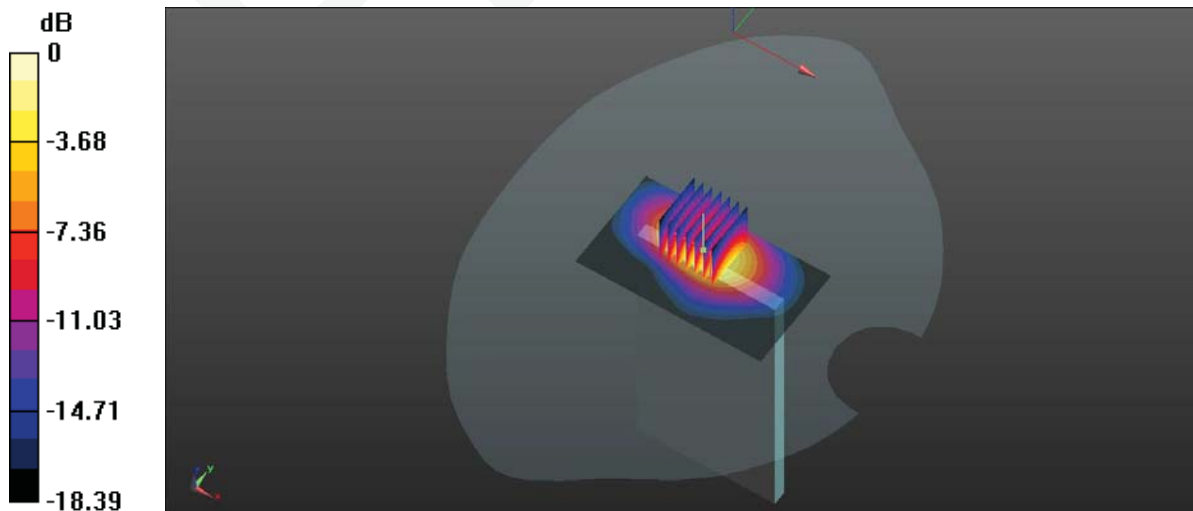

0 dB = 1.59 W/kg = 2.01 dBW/kg

**Test Laboratory: Bay Area Compliance Labs Corp.(Dongguan)**

**Test Plot 5#:WCDMA 850 Left Cheek High Channel**

**DUT: Gravity 5.5LTE; Type: Gravity 5.5LTE**

Communication System: BAND V; Frequency: 846.6 MHz;Duty Cycle: 1:1  
 Medium parameters used:  $f = 846.6 \text{ MHz}$ ;  $\sigma = 0.895 \text{ S/m}$ ;  $\epsilon_r = 42.803$ ;  $\rho = 1000 \text{ kg/m}^3$   
 Phantom section: Left Section

DASY5 Configuration:

- Probe: EX3DV4 - SN7329; ConvF(9.52, 9.52, 9.52); Calibrated: 2015/2/5;
- Sensor-Surface: 4mm (Mechanical Surface Detection)
- Electronics: DAE4 Sn1459; Calibrated: 2015/1/26
- Phantom: SAM (30deg probe tilt) with CRP v5.0\_20150321; Type: QD000P40CD; Serial: TP:1874
- Measurement SW: DASY52, Version 52.8 (8);

**Head/WCDMA 850 Left Cheek/Area Scan (71x111x1):** Interpolated grid:  $dx=1.500 \text{ mm}$ ,  $dy=1.500 \text{ mm}$   
 Maximum value of SAR (interpolated) = 0.0549 W/kg

**Head/WCDMA 850 Left Cheek/Zoom Scan (7x7x7)/Cube 0:** Measurement grid:  $dx=5\text{mm}$ ,  $dy=5\text{mm}$ ,  $dz=5\text{mm}$   
 Reference Value = 2.028 V/m; Power Drift = -0.17 dB  
 Peak SAR (extrapolated) = 0.0570 W/kg  
**SAR(1 g) = 0.044 W/kg; SAR(10 g) = 0.031 W/kg**  
 Maximum value of SAR (measured) = 0.0458 W/kg

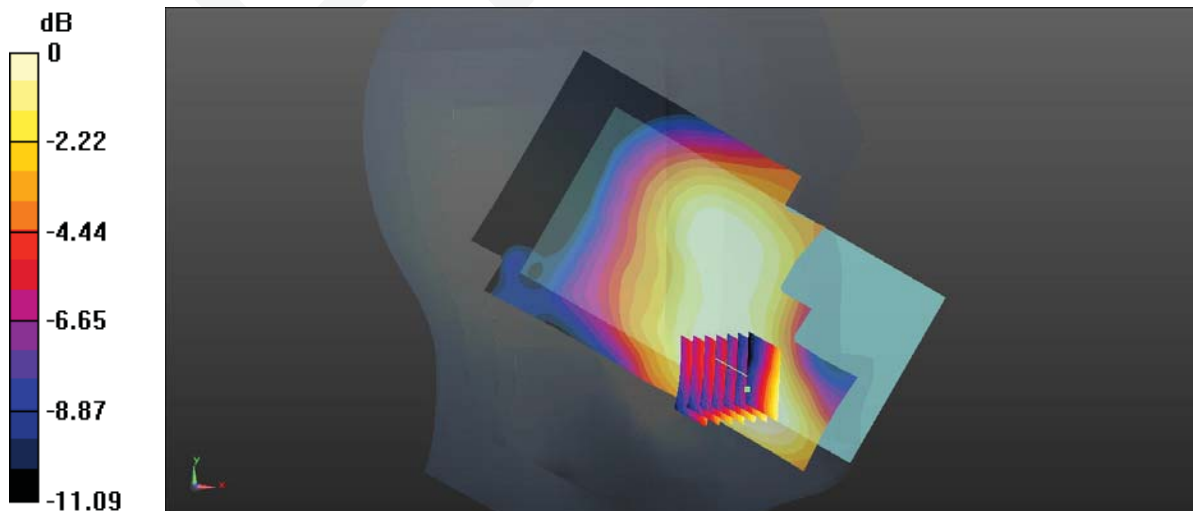

0 dB = 0.0458 W/kg = -13.39 dBW/kg

**Test Laboratory: Bay Area Compliance Labs Corp.(Dongguan)**

**Test Plot 6#:WCDMA 850 Back High Channel**

**DUT: Gravity 5.5LTE; Type: Gravity 5.5LTE**

Communication System: BAND V; Frequency: 846.6 MHz;Duty Cycle: 1:1  
 Medium parameters used:  $f = 846.6 \text{ MHz}$ ;  $\sigma = 0.985 \text{ S/m}$ ;  $\epsilon_r = 55.034$ ;  $\rho = 1000 \text{ kg/m}^3$   
 Phantom section: Flat Section

DASY5 Configuration:

- Probe: EX3DV4 - SN7329; ConvF(9.17, 9.17, 9.17); Calibrated: 2015/2/5;
- Sensor-Surface: 4mm (Mechanical Surface Detection)
- Electronics: DAE4 Sn1459; Calibrated: 2015/1/26
- Phantom: SAM (30deg probe tilt) with CRP v5.0\_20150321; Type: QD000P40CD; Serial: TP:1874
- Measurement SW: DASY52, Version 52.8 (8);

**Body/WCDMA 850 Back/Area Scan (71x121x1):** Interpolated grid:  $dx=1.500 \text{ mm}$ ,  $dy=1.500 \text{ mm}$   
 Maximum value of SAR (interpolated) = 0.283 W/kg

**Body/WCDMA 850 Back/Zoom Scan (7x7x7)/Cube 0:** Measurement grid:  $dx=5\text{mm}$ ,  $dy=5\text{mm}$ ,  $dz=5\text{mm}$   
 Reference Value = 13.82 V/m; Power Drift = 0.04 dB  
 Peak SAR (extrapolated) = 0.376 W/kg  
**SAR(1 g) = 0.273 W/kg; SAR(10 g) = 0.193 W/kg**  
 Maximum value of SAR (measured) = 0.289 W/kg

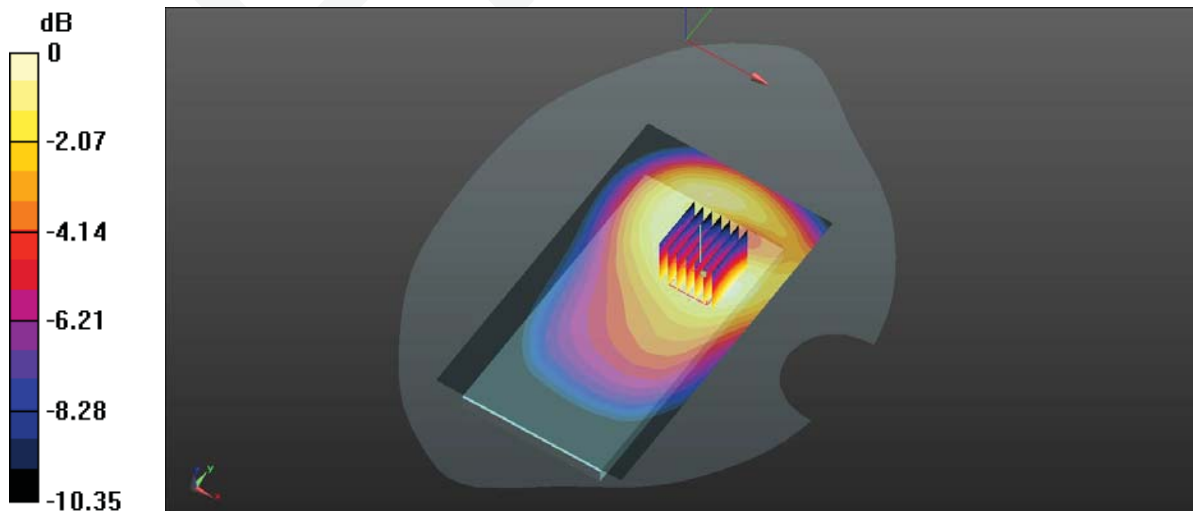

0 dB = 0.289 W/kg = -5.39 dBW/kg



**Test Laboratory: Bay Area Compliance Labs Corp.(Dongguan)**

**Test Plot 7#:WCDMA 1750 Right High Channel**

**DUT: Gravity 5.5LTE; Type: Gravity 5.5LTE**

Communication System: Generic BAND IV; Frequency: 1752.6 MHz;Duty Cycle: 1:1  
 Medium parameters used:  $f = 1752.6 \text{ MHz}$ ;  $\sigma = 1.389 \text{ S/m}$ ;  $\epsilon_r = 40.333$ ;  $\rho = 1000 \text{ kg/m}^3$   
 Phantom section: Right Section

DASY5 Configuration:

- Probe: EX3DV4 - SN7329; ConvF(8.12, 8.12, 8.12); Calibrated: 2015/2/5;
- Sensor-Surface: 4mm (Mechanical Surface Detection)
- Electronics: DAE4 Sn1459; Calibrated: 2015/1/26
- Phantom: SAM (30deg probe tilt) with CRP v5.0\_20150321; Type: QD000P40CD; Serial: TP:1874
- Measurement SW: DASY52, Version 52.8 (8);

**Head/WCDMA 1750 Right/Area Scan (71x121x1):** Interpolated grid:  $dx=1.500 \text{ mm}$ ,  $dy=1.500 \text{ mm}$   
 Maximum value of SAR (interpolated) = 0.331 W/kg

**Head/WCDMA 1750 Right/Zoom Scan (7x7x7)/Cube 0:** Measurement grid:  $dx=5\text{mm}$ ,  $dy=5\text{mm}$ ,  $dz=5\text{mm}$   
 Reference Value = 6.353 V/m; Power Drift = 0.16 dB  
 Peak SAR (extrapolated) = 0.374 W/kg  
**SAR(1 g) = 0.308 W/kg; SAR(10 g) = 0.247 W/kg**  
 Maximum value of SAR (measured) = 0.318 W/kg

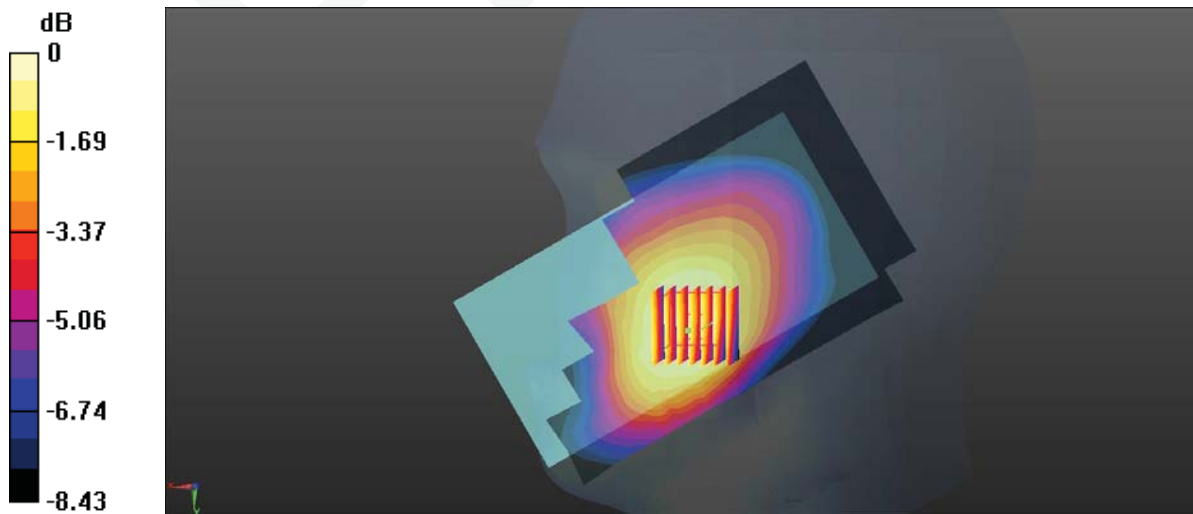

0 dB = 0.318 W/kg = -4.98 dBW/kg

**Test Laboratory: Bay Area Compliance Labs Corp.(Dongguan)**

**Test Plot 8#:WCDMA 1750 Bottom High Channel**

**DUT: Gravity 5.5LTE; Type: Gravity 5.5LTE**

Communication System: Generic BAND IV; Frequency: 1752.6 MHz;Duty Cycle: 1:1  
 Medium parameters used:  $f = 1752.6 \text{ MHz}$ ;  $\sigma = 1.492 \text{ S/m}$ ;  $\epsilon_r = 55.324$ ;  $\rho = 1000 \text{ kg/m}^3$   
 Phantom section: Flat Section

DASY5 Configuration:

- Probe: EX3DV4 - SN7329; ConvF(7.85, 7.85, 7.85); Calibrated: 2015/2/5;
- Sensor-Surface: 4mm (Mechanical Surface Detection)
- Electronics: DAE4 Sn1459; Calibrated: 2015/1/26
- Phantom: SAM (30deg probe tilt) with CRP v5.0\_20150321; Type: QD000P40CD; Serial: TP:1874
- Measurement SW: DASY52, Version 52.8 (8);

**Body/WCDMA 1750 Bottom/Area Scan (71x41x1):** Interpolated grid:  $dx=1.500 \text{ mm}$ ,  $dy=1.500 \text{ mm}$

Maximum value of SAR (interpolated) = 2.26 W/kg

**Body/WCDMA 1750 Bottom/Zoom Scan (7x7x7)/Cube 0:** Measurement grid:  $dx=5\text{mm}$ ,  $dy=5\text{mm}$ ,  $dz=5\text{mm}$

Reference Value = 24.53 V/m; Power Drift = -0.13 dB

Peak SAR (extrapolated) = 3.31 W/kg

**SAR(1 g) = 1.08 W/kg; SAR(10 g) = 0.588 W/kg**

Maximum value of SAR (measured) = 1.43 W/kg

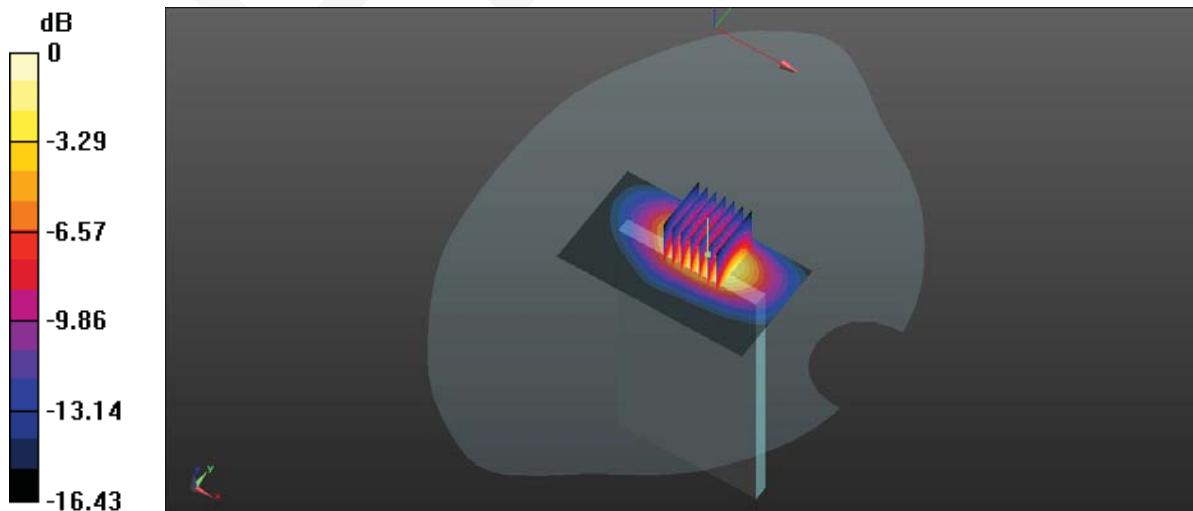

0 dB = 1.43 W/kg = 1.55 dBW/kg

**Test Laboratory: Bay Area Compliance Labs Corp.(Dongguan)**

**Test Plot 9#:WCDMA 1900 Right Middle Channel**

**DUT: Gravity 5.5LTE; Type: Gravity 5.5LTE**

Communication System: Generic LTE; Frequency: 1880 MHz;Duty Cycle: 1:1  
 Medium parameters used:  $f = 1880 \text{ MHz}$ ;  $\sigma = 1.386 \text{ S/m}$ ;  $\epsilon_r = 39.742$ ;  $\rho = 1000 \text{ kg/m}^3$   
 Phantom section: Right Section

DASY5 Configuration:

- Probe: EX3DV4 - SN7329; ConvF(8.12, 8.12, 8.12); Calibrated: 2015/2/5;
- Sensor-Surface: 4mm (Mechanical Surface Detection)
- Electronics: DAE4 Sn1459; Calibrated: 2015/1/26
- Phantom: SAM (30deg probe tilt) with CRP v5.0\_20150321; Type: QD000P40CD; Serial: TP:1874
- Measurement SW: DASY52, Version 52.8 (8);

**Head/WCDMA 1900 Right/Area Scan (71x121x1):** Interpolated grid:  $dx=1.500 \text{ mm}$ ,  $dy=1.500 \text{ mm}$   
 Maximum value of SAR (interpolated) = 0.285 W/kg

**Head/WCDMA 1900 Right/Zoom Scan (7x7x7)/Cube 0:** Measurement grid:  $dx=5\text{mm}$ ,  $dy=5\text{mm}$ ,  $dz=5\text{mm}$   
 Reference Value = 3.093 V/m; Power Drift = -0.01 dB  
 Peak SAR (extrapolated) = 0.378 W/kg  
**SAR(1 g) = 0.241 W/kg; SAR(10 g) = 0.147 W/kg**  
 Maximum value of SAR (measured) = 0.261 W/kg

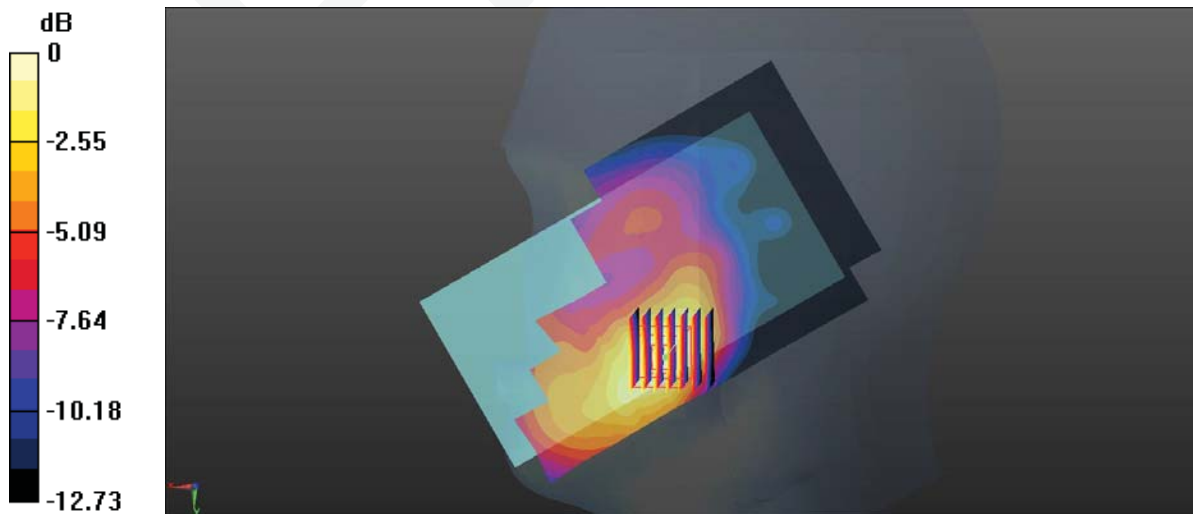

0 dB = 0.261 W/kg = -5.83 dBW/kg

**Test Laboratory: Bay Area Compliance Labs Corp.(Dongguan)**

**Test Plot 10#:WCDMA 1900 Bottom Middle Channel**

**DUT: Gravity 5.5LTE; Type: Gravity 5.5LTE**

Communication System: Generic LTE; Frequency: 1880 MHz;Duty Cycle: 1:1  
 Medium parameters used:  $f = 1880 \text{ MHz}$ ;  $\sigma = 1.545 \text{ S/m}$ ;  $\epsilon_r = 53.741$ ;  $\rho = 1000 \text{ kg/m}^3$   
 Phantom section: Flat Section

DASY5 Configuration:

- Probe: EX3DV4 - SN7329; ConvF(7.56, 7.56, 7.56); Calibrated: 2015/2/5;
- Sensor-Surface: 4mm (Mechanical Surface Detection)
- Electronics: DAE4 Sn1459; Calibrated: 2015/1/26
- Phantom: SAM (30deg probe tilt) with CRP v5.0\_20150321; Type: QD000P40CD; Serial: TP:1874
- Measurement SW: DASY52, Version 52.8 (8);

**Body/WCDMA 1900 Bottom/Area Scan (71x41x1):** Interpolated grid:  $dx=1.500 \text{ mm}$ ,  $dy=1.500 \text{ mm}$   
 Maximum value of SAR (interpolated) = 2.25 W/kg

**Body/WCDMA 1900 Bottom/Zoom Scan (7x7x7)/Cube 0:** Measurement grid:  $dx=5\text{mm}$ ,  $dy=5\text{mm}$ ,  $dz=5\text{mm}$   
 Reference Value = 26.25 V/m; Power Drift = 0.07 dB  
 Peak SAR (extrapolated) = 3.64 W/kg  
**SAR(1 g) = 1.22 W/kg; SAR(10 g) = 0.652 W/kg**  
 Maximum value of SAR (measured) = 1.41 W/kg

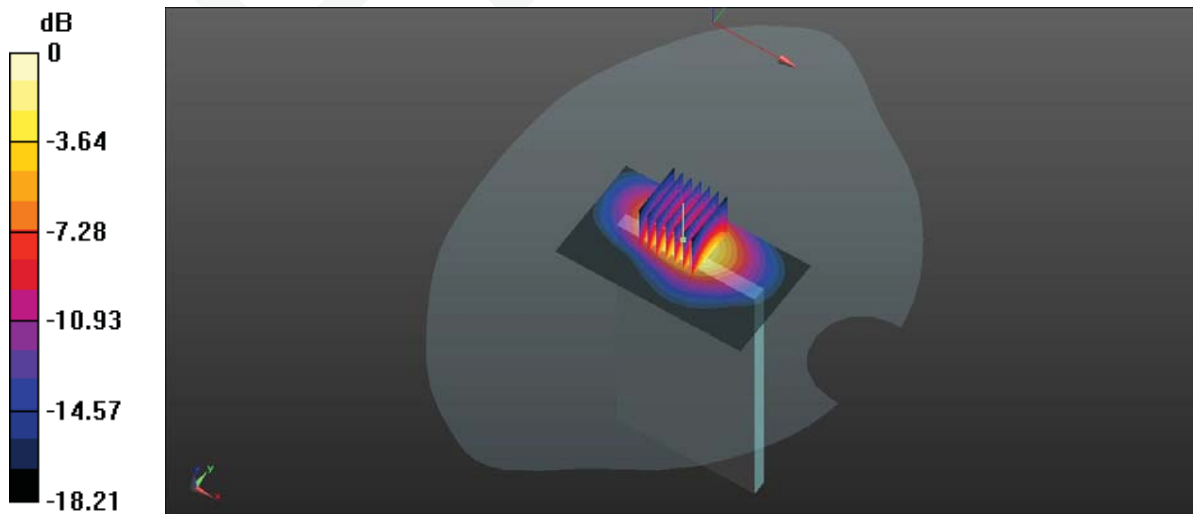

0 dB = 1.41 W/kg = 1.49 dBW/kg

**Test Laboratory: Bay Area Compliance Labs Corp.(Dongguan)**

**Test Plot 11#:LTE Band 2 Right Middle Channel**

**DUT: Gravity 5.5LTE; Type: Gravity 5.5LTE**

Communication System: Generic LTE; Frequency: 1880 MHz;Duty Cycle: 1:1  
 Medium parameters used:  $f = 1880$  MHz;  $\sigma = 1.386$  S/m;  $\epsilon_r = 39.742$ ;  $\rho = 1000$  kg/m<sup>3</sup>  
 Phantom section: Right Section

DASY5 Configuration:

- Probe: EX3DV4 - SN7329; ConvF(7.88, 7.88, 7.88); Calibrated: 2015/2/5;
- Sensor-Surface: 4mm (Mechanical Surface Detection)
- Electronics: DAE4 Sn1459; Calibrated: 2015/1/26
- Phantom: SAM (30deg probe tilt) with CRP v5.0\_20150321; Type: QD000P40CD; Serial: TP:1874
- Measurement SW: DASY52, Version 52.8 (8);

**Head/LTE Band 2 Right/Area Scan (71x121x1):** Interpolated grid: dx=1.500 mm, dy=1.500 mm  
 Maximum value of SAR (interpolated) = 0.132 W/kg

**Head/LTE Band 2 Right/Zoom Scan (7x7x7)/Cube 0:** Measurement grid: dx=5mm, dy=5mm, dz=5mm  
 Reference Value = 2.066 V/m; Power Drift = 0.15 dB  
 Peak SAR (extrapolated) = 0.168 W/kg  
**SAR(1 g) = 0.112 W/kg; SAR(10 g) = 0.072 W/kg**  
 Maximum value of SAR (measured) = 0.120 W/kg

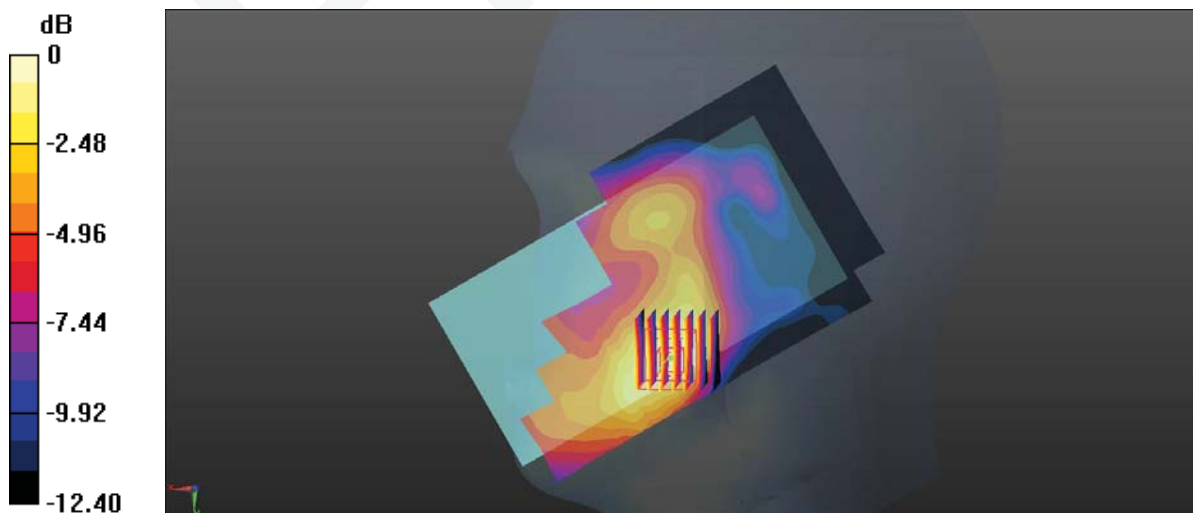

0 dB = 0.120 W/kg = -9.21 dBW/kg

**Test Laboratory: Bay Area Compliance Labs Corp.(Dongguan)**

**Test Plot 12#:LTE Band 2 Bottom Middle Channel**

**DUT: Gravity 5.5LTE; Type: Gravity 5.5LTE**

Communication System: Generic LTE; Frequency: 1880 MHz;Duty Cycle: 1:1  
 Medium parameters used:  $f = 1880 \text{ MHz}$ ;  $\sigma = 1.545 \text{ S/m}$ ;  $\epsilon_r = 53.741$ ;  $\rho = 1000 \text{ kg/m}^3$   
 Phantom section: Flat Section

DASY5 Configuration:

- Probe: EX3DV4 - SN7329; ConvF(7.56, 7.56, 7.56); Calibrated: 2015/2/5;
- Sensor-Surface: 4mm (Mechanical Surface Detection)
- Electronics: DAE4 Sn1459; Calibrated: 2015/1/26
- Phantom: SAM (30deg probe tilt) with CRP v5.0\_20150321; Type: QD000P40CD; Serial: TP:1874
- Measurement SW: DASY52, Version 52.8 (8);

**Body/LTE Band 2 Bottom/Area Scan (71x41x1):** Interpolated grid:  $dx=1.500 \text{ mm}$ ,  $dy=1.500 \text{ mm}$

Maximum value of SAR (interpolated) = 1.98 W/kg

**Body/LTE Band 2 Bottom/Zoom Scan (7x7x7)/Cube 0:** Measurement grid:  $dx=5\text{mm}$ ,  $dy=5\text{mm}$ ,  $dz=5\text{mm}$

Reference Value = 27.29 V/m; Power Drift = -0.11 dB

Peak SAR (extrapolated) = 2.97 W/kg

**SAR(1 g) = 1.11 W/kg; SAR(10 g) = 0.549 W/kg**

Maximum value of SAR (measured) = 1.35 W/kg

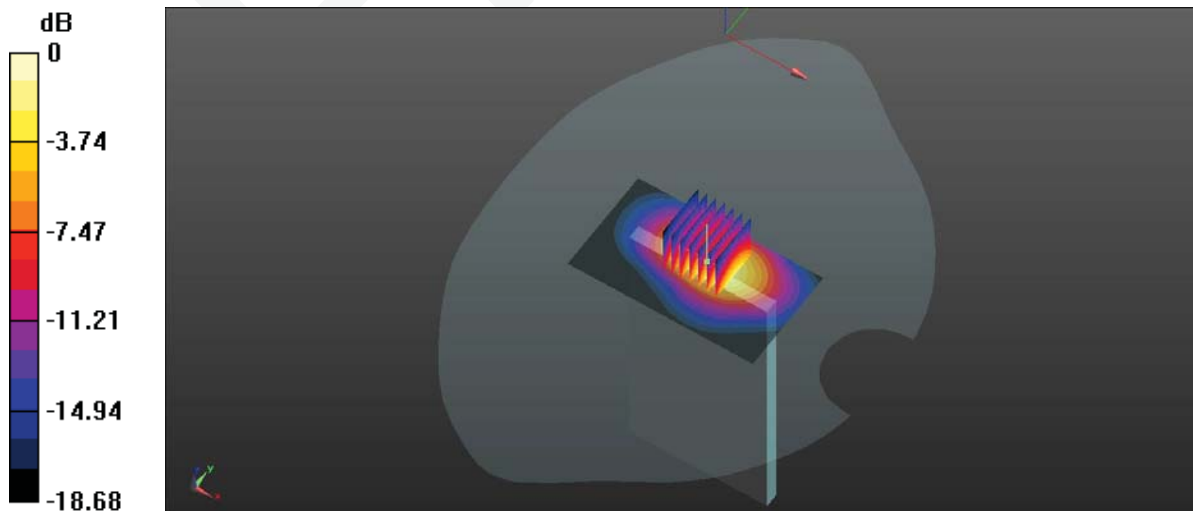

0 dB = 1.35 W/kg = 1.30 dBW/kg

**Test Laboratory: Bay Area Compliance Labs Corp.(Dongguan)**

**Test Plot 13#:LTE Band 4 Right Cheek Low Channel**

**DUT: Gravity 5.5LTE; Type: Gravity 5.5LTE**

Communication System: Generic LTE; Frequency: 1720 MHz;Duty Cycle: 1:1  
 Medium parameters used:  $f = 1720$  MHz;  $\sigma = 1.36$  S/m;  $\epsilon_r = 40.448$ ;  $\rho = 1000$  kg/m<sup>3</sup>  
 Phantom section: Right Section

DASY5 Configuration:

- Probe: EX3DV4 - SN7329; ConvF(8.12, 8.12, 8.12); Calibrated: 2015/2/5;
- Sensor-Surface: 4mm (Mechanical Surface Detection)
- Electronics: DAE4 Sn1459; Calibrated: 2015/1/26
- Phantom: SAM (30deg probe tilt) with CRP v5.0\_20150321; Type: QD000P40CD; Serial: TP:1874
- Measurement SW: DASY52, Version 52.8 (8);

**Head/LTE Band 4 Right Cheek/Area Scan (71x121x1):** Interpolated grid: dx=1.500 mm, dy=1.500 mm

Maximum value of SAR (interpolated) = 0.114 W/kg

**Head/LTE Band 4 Right Cheek/Zoom Scan (7x7x7)/Cube 0:** Measurement grid: dx=5mm, dy=5mm, dz=5mm

Reference Value = 2.521 V/m; Power Drift = -0.06 dB

Peak SAR (extrapolated) = 0.144 W/kg

**SAR(1 g) = 0.097 W/kg; SAR(10 g) = 0.062 W/kg**

Maximum value of SAR (measured) = 0.105 W/kg

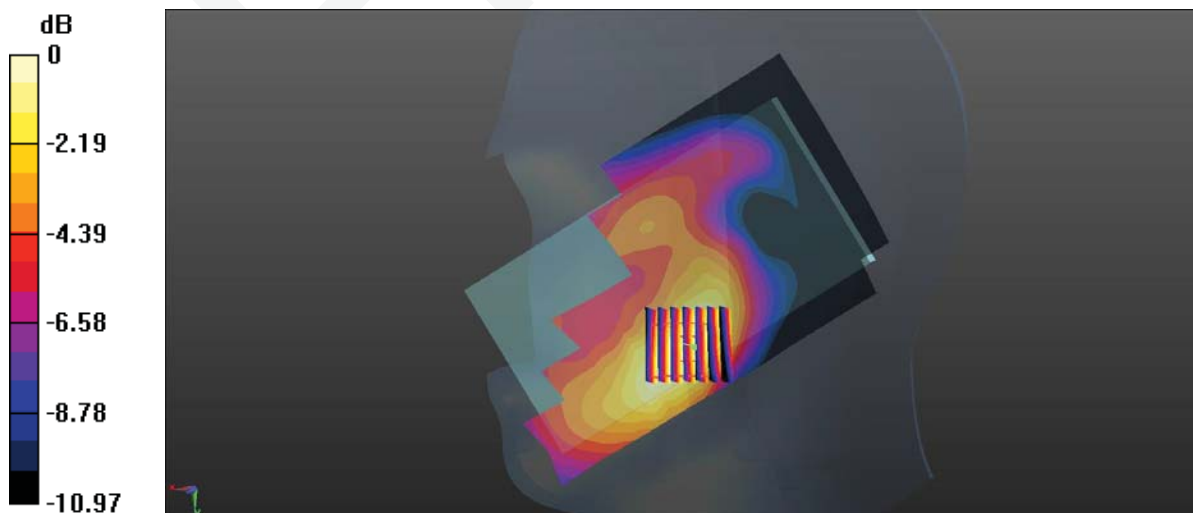

0 dB = 0.105 W/kg = -9.79 dBW/kg

**Test Laboratory: Bay Area Compliance Labs Corp.(Dongguan)**

**Test Plot 14#:LTE Band 4 Bottom Low Channel**

**DUT: Gravity 5.5LTE; Type: Gravity 5.5LTE**

Communication System: Generic LTE; Frequency: 1720 MHz;Duty Cycle: 1:1  
 Medium parameters used:  $f = 1720$  MHz;  $\sigma = 1.463$  S/m;  $\epsilon_r = 53.48$ ;  $\rho = 1000$  kg/m<sup>3</sup>  
 Phantom section: Flat Section

DASY5 Configuration:

- Probe: EX3DV4 - SN7329; ConvF(7.85, 7.85, 7.85); Calibrated: 2015/2/5;
- Sensor-Surface: 4mm (Mechanical Surface Detection)
- Electronics: DAE4 Sn1459; Calibrated: 2015/1/26
- Phantom: SAM (30deg probe tilt) with CRP v5.0\_20150321; Type: QD000P40CD; Serial: TP:1874
- Measurement SW: DASY52, Version 52.8 (8);

**Body/LTE Band 4 Bottom/Area Scan (71x41x1):** Interpolated grid: dx=1.500 mm, dy=1.500 mm

Maximum value of SAR (interpolated) = 1.17 W/kg

**Body/LTE Band 4 Bottom/Zoom Scan (7x7x7)/Cube 0:** Measurement grid: dx=5mm, dy=5mm, dz=5mm

Reference Value = 19.93 V/m; Power Drift = 0.01 dB

Peak SAR (extrapolated) = 1.61 W/kg

**SAR(1 g) = 0.914 W/kg; SAR(10 g) = 0.476 W/kg**

Maximum value of SAR (measured) = 1.04 W/kg

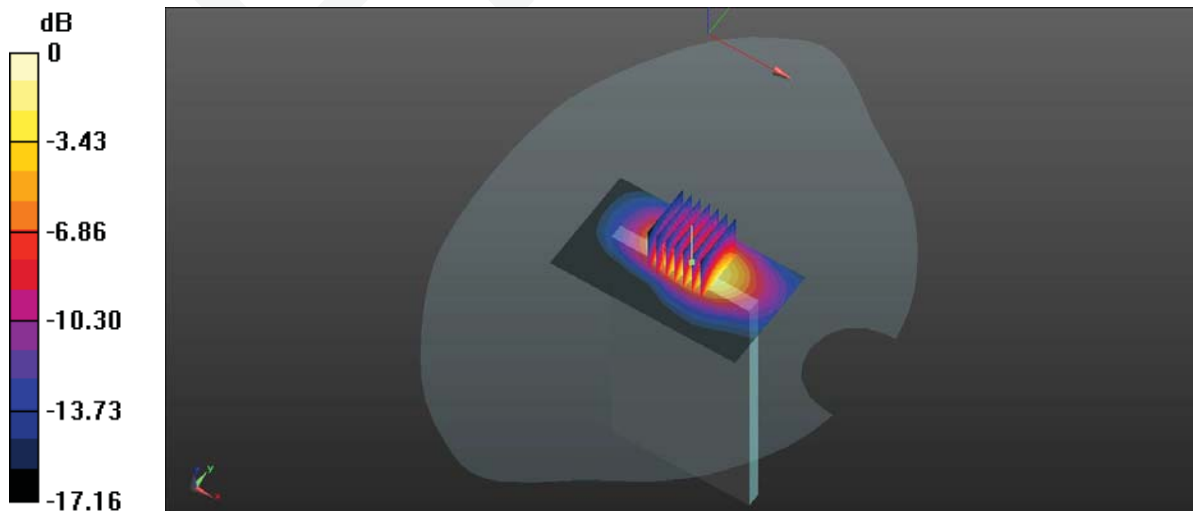

0 dB = 1.04 W/kg = 0.17 dBW/kg



**Test Laboratory: Bay Area Compliance Labs Corp.(Dongguan)**

**Test Plot 15#:LTE Band 7 Right Middle Channel**

**DUT: Gravity 5.5LTE; Type: Gravity 5.5LTE**

Communication System: Generic LTE; Frequency: 2535 MHz;Duty Cycle: 1:1  
 Medium parameters used: f = 2535 MHz;  $\sigma = 1.81$  S/m;  $\epsilon_r = 39.19$ ;  $\rho = 1000$  kg/m<sup>3</sup>  
 Phantom section: Right Section

DASY5 Configuration:

- Probe: EX3DV4 - SN7329; ConvF(7.06, 7.06, 7.06); Calibrated: 2015/2/5;
- Sensor-Surface: 4mm (Mechanical Surface Detection)
- Electronics: DAE4 Sn1459; Calibrated: 2015/1/26
- Phantom: SAM (30deg probe tilt) with CRP v5.0\_20150321; Type: QD000P40CD; Serial: TP:1874
- Measurement SW: DASY52, Version 52.8 (8);

**Head/LTE Band 7 Right/Area Scan (71x121x1):** Interpolated grid: dx=1.500 mm, dy=1.500 mm  
 Maximum value of SAR (interpolated) = 0.205 W/kg

**Head/LTE Band 7 Right/Zoom Scan (7x7x7)/Cube 0:** Measurement grid: dx=5mm, dy=5mm, dz=5mm  
 Reference Value = 2.475 V/m; Power Drift = 0.2 dB  
 Peak SAR (extrapolated) = 0.248 W/kg  
**SAR(1 g) = 0.168 W/kg; SAR(10 g) = 0.107 W/kg**  
 Maximum value of SAR (measured) = 0.181 W/kg

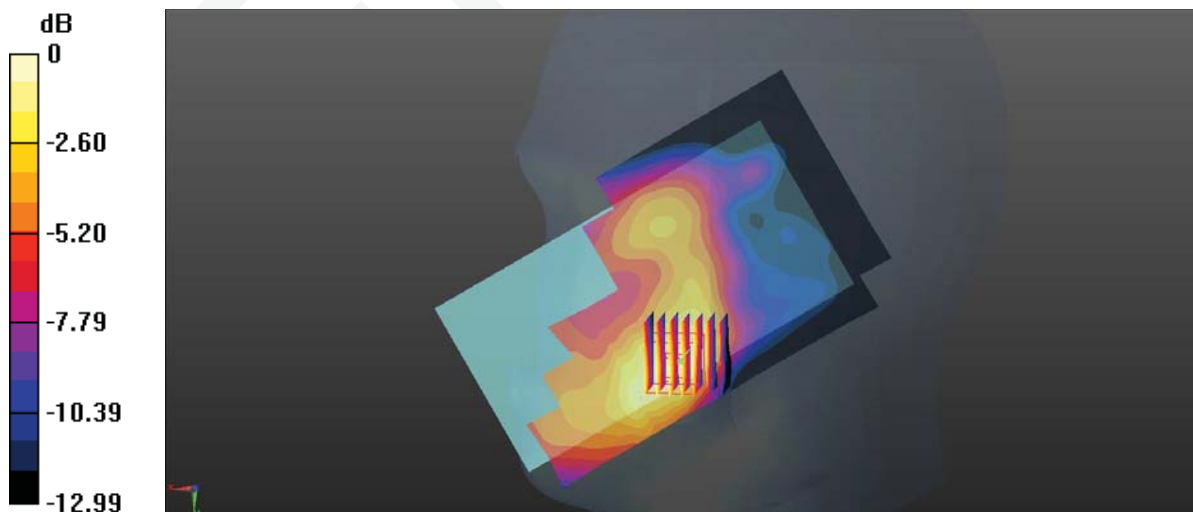

0 dB = 0.181 W/kg = -7.42 dBW/kg

**Test Laboratory: Bay Area Compliance Labs Corp.(Dongguan)**

**Test Plot 16#:LTE Band 7 Bottom Middle Channel**

**DUT: Gravity 5.5LTE; Type: Gravity 5.5LTE**

Communication System: Generic LTE; Frequency: 2535 MHz;Duty Cycle: 1:1  
 Medium parameters used:  $f = 2535 \text{ MHz}$ ;  $\sigma = 1.95 \text{ S/m}$ ;  $\epsilon_r = 52.69$ ;  $\rho = 1000 \text{ kg/m}^3$   
 Phantom section: Flat Section

DASY5 Configuration:

- Probe: EX3DV4 - SN7329; ConvF(7.2, 7.2, 7.2); Calibrated: 2015/2/5;
- Sensor-Surface: 4mm (Mechanical Surface Detection)
- Electronics: DAE4 Sn1459; Calibrated: 2015/1/26
- Phantom: SAM (30deg probe tilt) with CRP v5.0\_20150321; Type: QD000P40CD; Serial: TP:1874
- Measurement SW: DASY52, Version 52.8 (8);

**Body/LTE Band 7 Bottom/Area Scan (71x41x1):** Interpolated grid:  $dx=1.500 \text{ mm}$ ,  $dy=1.500 \text{ mm}$

Maximum value of SAR (interpolated) = 1.64 W/kg

**Body/LTE Band 7 Bottom/Zoom Scan (7x7x7)/Cube 0:** Measurement grid:  $dx=5\text{mm}$ ,  $dy=5\text{mm}$ ,  $dz=5\text{mm}$

Reference Value = 23.65 V/m; Power Drift = 0.03 dB

Peak SAR (extrapolated) = 2.29 W/kg

**SAR(1 g) = 1.01 W/kg; SAR(10 g) = 0.528 W/kg**

Maximum value of SAR (measured) = 1.19 W/kg

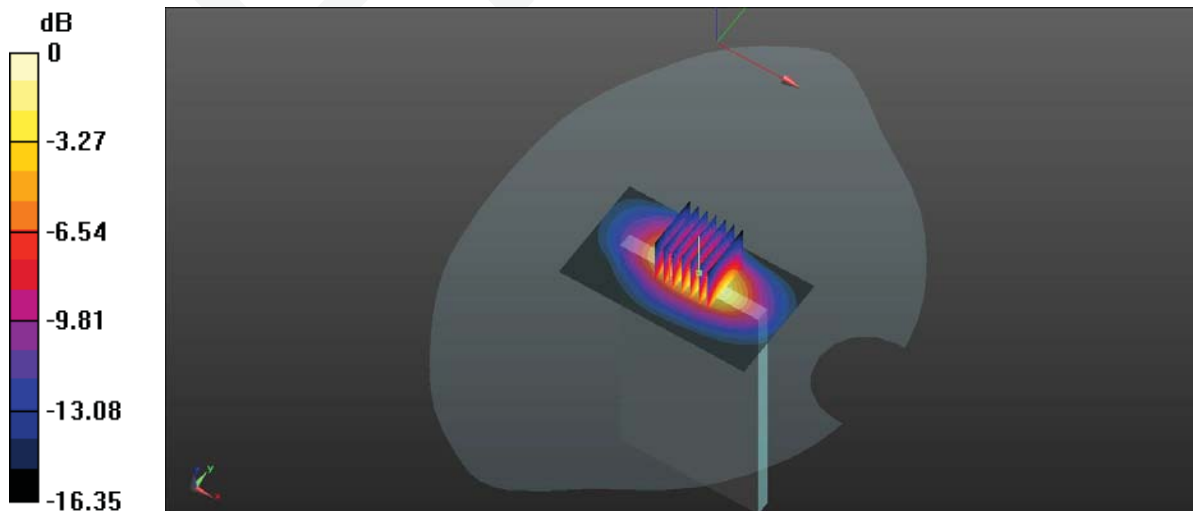

0 dB = 1.19 W/kg = 0.755 dBW/kg

## APPENDIX A MEASUREMENT UNCERTAINTY

The uncertainty budget has been determined for the measurement system and is given in the following Table.

### Measurement uncertainty evaluation for IEEE1528-2013 SAR test

Source of uncertainty	Tolerance/ uncertainty ± %	Probability distribution	Disisor	ci (1 g)	ci (10 g)	Standard uncertainty ± %, (1 g)	Standard uncertainty ± %, (10 g)
<b>Measurement system</b>							
Probe calibration	6.55	N	1	1	1	6.6	6.6
Axial Isotropy	4.7	R	$\sqrt{3}$	1	1	2.7	2.7
Hemispherical Isotropy	9.6	R	$\sqrt{3}$	0	0	0.0	0.0
Boundary effect	1.0	R	$\sqrt{3}$	1	1	0.6	0.6
Linearity	4.7	R	$\sqrt{3}$	1	1	2.7	2.7
Detection limits	1.0	R	$\sqrt{3}$	1	1	0.6	0.6
Readout electronics	0.3	N	1	1	1	0.3	0.3
Response time	0.0	R	$\sqrt{3}$	1	1	0.0	0.0
Integration time	0.0	R	$\sqrt{3}$	1	1	0.0	0.0
RF ambient conditions – noise	1.0	R	$\sqrt{3}$	1	1	0.6	0.6
RF ambient conditions–reflections	1.0	R	$\sqrt{3}$	1	1	0.6	0.6
Probe positioner mech. Restrictions	0.8	R	$\sqrt{3}$	1	1	0.5	0.5
Probe positioning with respect to phantom shell	6.7	R	$\sqrt{3}$	1	1	3.9	3.9
Post-processing	2.0	R	$\sqrt{3}$	1	1	1.2	1.2
<b>Test sample related</b>							
Test sample positioning	2.8	N	1	1	1	2.8	2.8
Device holder uncertainty	6.3	N	1	1	1	6.3	6.3
Drift of output power	5.0	R	$\sqrt{3}$	1	1	2.9	2.9
<b>Phantom and set-up</b>							
Phantom uncertainty (shape and thickness tolerances)	4.0	R	$\sqrt{3}$	1	1	2.3	2.3
Liquid conductivity target)	5.0	R	$\sqrt{3}$	0.64	0.43	1.8	1.2
Liquid conductivity meas.)	2.5	N	1	0.64	0.43	1.6	1.1
Liquid permittivity target)	5.0	R	$\sqrt{3}$	0.6	0.49	1.7	1.4
Liquid permittivity meas.)	2.5	N	1	0.6	0.49	1.5	1.2
Combined standard uncertainty		RSS				12.2	12.0
Expanded uncertainty 95 % confidence interval)						24.3	23.9

Measurement uncertainty evaluation for IEC62209-2 SAR test

Source of uncertainty	Tolerance/uncertainty ± %	Probability distribution	Disisor	ci (1 g)	ci (10 g)	Standard uncertainty ± %, (1 g)	Standard uncertainty ± %, (10 g)
<b>Measurement system</b>							
Probe calibration	6.55	N	1	1	1	6.6	6.6
Axial Isotropy	4.7	R	√3	1	1	2.7	2.7
Hemispherical Isotropy	9.6	R	√3	0	0	0.0	0.0
Linearity	4.7	R	√3	1	1	2.7	2.7
Modulation Response	0.0	R	√3	1	1	0.0	0.0
Detection limits	1.0	R	√3	1	1	0.6	0.6
Boundary effect	1.0	R	√3	1	1	0.6	0.6
Readout electronics	0.3	N	1	1	1	0.3	0.3
Response time	0.0	R	√3	1	1	0.0	0.0
Integration time	0.0	R	√3	1	1	0.0	0.0
RF ambient conditions – noise	1.0	R	√3	1	1	0.6	0.6
RF ambient conditions–reflections	1.0	R	√3	1	1	0.6	0.6
Probe positioner mech. Restrictions	0.8	R	√3	1	1	0.5	0.5
Probe positioning with respect to phantom shell	6.7	R	√3	1	1	3.9	3.9
Post-processing	2.0	R	√3	1	1	1.2	1.2
<b>Test sample related</b>							
Device holder Uncertainty	6.3	N	1	1	1	6.3	6.3
Test sample positioning	2.8	N	1	1	1	2.8	2.8
Power scaling	4.5	R	√3	1	1	2.6	2.6
Drift of output power	5.0	R	√3	1	1	2.9	2.9
<b>Phantom and set-up</b>							
Phantom uncertainty (shape and thickness tolerances)	4.0	R	√3	1	1	2.3	2.3
Algorithm for correcting SAR for deviations in permittivity and conductivity	1.9	N	1	1	0.84	1.1	0.9
Liquid conductivity (meas.)	2.5	N	1	0.64	0.43	1.6	1.1
Liquid permittivity (meas.)	2.5	N	1	0.6	0.49	1.5	1.2
Temp. unc. - Conductivity	1.7	R	√3	0.78	0.71	0.8	0.7
Temp. unc. - Permittivity	0.3	R	√3	0.23	0.26	0.0	0.0
Combined standard uncertainty		RSS				12.2	12.1
Expanded uncertainty 95 % confidence interval)						24.5	24.2

## APPENDIX B – PROBE CALIBRATION CERTIFICATES

**Calibration Laboratory of  
Schmid & Partner  
Engineering AG**  
Zeughausstrasse 43, 8004 Zurich, Switzerland



**S** Schweizerischer Kalibrierdienst  
**C** Service suisse d'étalonnage  
**S** Servizio svizzero di taratura  
**S** Swiss Calibration Service

Accredited by the Swiss Accreditation Service (SAS)  
The Swiss Accreditation Service is one of the signatories to the EA  
Multilateral Agreement for the recognition of calibration certificates

Accreditation No.: **SCS 0108**

Client **BACL China (Vitec)**

Certificate No: **EX3-7329\_Feb15**

### CALIBRATION CERTIFICATE

Object **EX3DV4 - SN:7329**

Calibration procedure(s) **QA CAL-01.v9, QA CAL-23.v5, QA CAL-25.v6  
Calibration procedure for dosimetric E-field probes**

Calibration date: **February 5, 2015**

This calibration certificate documents the traceability to national standards, which realize the physical units of measurements (SI).  
The measurements and the uncertainties with confidence probability are given on the following pages and are part of the certificate.

All calibrations have been conducted in the closed laboratory facility: environment temperature (22 ± 3)°C and humidity < 70%.

Calibration Equipment used (M&TE critical for calibration)

Primary Standards	ID	Cal Date (Certificate No.)	Scheduled Calibration
Power meter E4419B	GB41293874	03-Apr-14 (No. 217-01911)	Apr-15
Power sensor E4412A	MY41498087	03-Apr-14 (No. 217-01911)	Apr-15
Reference 3 dB Attenuator	SN: S5054 (3c)	03-Apr-14 (No. 217-01915)	Apr-15
Reference 20 dB Attenuator	SN: S6277 (20x)	03-Apr-14 (No. 217-01919)	Apr-15
Reference 30 dB Attenuator	SN: S5129 (30b)	03-Apr-14 (No. 217-01920)	Apr-15
Reference Probe ES3DV2	SN: 3013	30-Dec-14 (No. ES3-3013_Dec14)	Dec-15
DAE4	SN: 660	14-Jan-15 (No. DAE4-660_Jan15)	Jan-16
Secondary Standards	ID	Check Date (in house)	Scheduled Check
RF generator HP 8648C	US3642U01700	4-Aug-99 (in house check Apr-13)	In house check: Apr-16
Network Analyzer HP 8753E	US37390585	18-Oct-01 (in house check Oct-14)	In house check: Oct-15

Calibrated by:	Name <b>Claudio Leubler</b>	Function <b>Laboratory Technician</b>	Signature 
Approved by:	<b>Katja Pokovic</b>	<b>Technical Manager</b>	
			issued: February 9, 2015
This calibration certificate shall not be reproduced except in full without written approval of the laboratory.			

Certificate No: **EX3-7329\_Feb15**

Page 1 of 11



**Calibration Laboratory of  
Schmid & Partner  
Engineering AG**  
Zeughausstrasse 43, 8004 Zurich, Switzerland



**S** Schweizerischer Kalibrierdienst  
**C** Service suisse d'étalonnage  
**S** Servizio svizzero di taratura  
**S** Swiss Calibration Service

Accredited by the Swiss Accreditation Service (SAS)  
The Swiss Accreditation Service is one of the signatories to the EA  
Multilateral Agreement for the recognition of calibration certificates

Accreditation No.: **SCS 0108**

**Glossary:**

TSL	tissue simulating liquid
NORM <sub>x,y,z</sub>	sensitivity in free space
ConvF	sensitivity in TSL / NORM <sub>x,y,z</sub>
DCP	diode compression point
CF	crest factor (1/duty_cycle) of the RF signal
A, B, C, D	modulation dependent linearization parameters
Polarization φ	φ rotation around probe axis
Polarization θ	θ rotation around an axis that is in the plane normal to probe axis (at measurement center), i.e., θ = 0 is normal to probe axis
Connector Angle	information used in DASY system to align probe sensor X to the robot coordinate system

**Calibration is Performed According to the Following Standards:**

- a) IEEE Std 1528-2013, "IEEE Recommended Practice for Determining the Peak Spatial-Averaged Specific Absorption Rate (SAR) in the Human Head from Wireless Communications Devices: Measurement Techniques", June 2013
- b) IEC 62209-1, "Procedure to measure the Specific Absorption Rate (SAR) for hand-held devices used in close proximity to the ear (frequency range of 300 MHz to 3 GHz)", February 2005

**Methods Applied and Interpretation of Parameters:**

- **NORM<sub>x,y,z</sub>**: Assessed for E-field polarization θ = 0 (f ≤ 900 MHz in TEM-cell; f > 1800 MHz: R22 waveguide). NORM<sub>x,y,z</sub> are only intermediate values, i.e., the uncertainties of NORM<sub>x,y,z</sub> does not affect the E<sup>2</sup>-field uncertainty inside TSL (see below ConvF).
- **NORM(f)<sub>x,y,z</sub> = NORM<sub>x,y,z</sub> \* frequency\_response** (see Frequency Response Chart). This linearization is implemented in DASY4 software versions later than 4.2. The uncertainty of the frequency response is included in the stated uncertainty of ConvF.
- **DCP<sub>x,y,z</sub>**: DCP are numerical linearization parameters assessed based on the data of power sweep with CW signal (no uncertainty required). DCP does not depend on frequency nor media.
- **PAR**: PAR is the Peak to Average Ratio that is not calibrated but determined based on the signal characteristics
- **A<sub>x,y,z</sub>; B<sub>x,y,z</sub>; C<sub>x,y,z</sub>; D<sub>x,y,z</sub>; VR<sub>x,y,z</sub>**: A, B, C, D are numerical linearization parameters assessed based on the data of power sweep for specific modulation signal. The parameters do not depend on frequency nor media. VR is the maximum calibration range expressed in RMS voltage across the diode.
- **ConvF and Boundary Effect Parameters**: Assessed in flat phantom using E-field (or Temperature Transfer Standard for f ≤ 800 MHz) and inside waveguide using analytical field distributions based on power measurements for f > 800 MHz. The same setups are used for assessment of the parameters applied for boundary compensation (alpha, depth) of which typical uncertainty values are given. These parameters are used in DASY4 software to improve probe accuracy close to the boundary. The sensitivity in TSL corresponds to NORM<sub>x,y,z</sub> \* ConvF whereby the uncertainty corresponds to that given for ConvF. A frequency dependent ConvF is used in DASY version 4.4 and higher which allows extending the validity from ± 50 MHz to ± 100 MHz.
- **Spherical isotropy (3D deviation from isotropy)**: in a field of low gradients realized using a flat phantom exposed by a patch antenna.
- **Sensor Offset**: The sensor offset corresponds to the offset of virtual measurement center from the probe tip (on probe axis). No tolerance required.
- **Connector Angle**: The angle is assessed using the information gained by determining the NORM<sub>x</sub> (no uncertainty required).

EX3DV4 – SN:7329

February 5, 2015

# Probe EX3DV4

## SN:7329

Manufactured: December 11, 2014  
Calibrated: February 5, 2015

Calibrated for DASY/EASY Systems  
(Note: non-compatible with DASY2 system!)

---

Certificate No: EX3-7329\_Feb15

Page 3 of 11

EX3DV4- SN:7329

February 5, 2015

**DASY/EASY - Parameters of Probe: EX3DV4 - SN:7329**

**Basic Calibration Parameters**

	Sensor X	Sensor Y	Sensor Z	Unc (k=2)
Norm ( $\mu V/(V/m)^2$ ) <sup>A</sup>	0.48	0.43	0.46	± 10.1 %
DCP (mV) <sup>B</sup>	96.7	97.6	94.2	

**Modulation Calibration Parameters**

UID	Communication System Name		A dB	B dB/ $\mu V$	C	D dB	VR mV	Unc <sup>C</sup> (k=2)
0	CW	X	0.0	0.0	1.0	0.00	137.9	±3.0 %
		Y	0.0	0.0	1.0		147.0	
		Z	0.0	0.0	1.0		150.5	

The reported uncertainty of measurement is stated as the standard uncertainty of measurement multiplied by the coverage factor k=2, which for a normal distribution corresponds to a coverage probability of approximately 95%.

<sup>A</sup> The uncertainties of NormX,Y,Z do not affect the E<sup>2</sup>-field uncertainty inside TSL (see Pages 5 and 6).  
<sup>B</sup> Numerical linearization parameter: uncertainty not required.  
<sup>C</sup> Uncertainty is determined using the max. deviation from linear response applying rectangular distribution and is expressed for the square of the field value.



EX3DV4- SN:7329

February 5, 2015

### DASY/EASY - Parameters of Probe: EX3DV4 - SN:7329

#### Calibration Parameter Determined in Head Tissue Simulating Media

f (MHz) <sup>c</sup>	Relative Permittivity <sup>f</sup>	Conductivity (S/m) <sup>f</sup>	ConvF X	ConvF Y	ConvF Z	Alpha <sup>g</sup>	Depth <sup>h</sup> (mm)	Unct. (k=2)
900	41.5	0.97	9.52	9.52	9.52	0.40	0.86	± 12.0 %
1750	40.1	1.37	8.12	8.12	8.12	0.29	0.90	± 12.0 %
1900	40.0	1.40	7.88	7.88	7.88	0.68	0.61	± 12.0 %
2450	39.2	1.80	7.06	7.06	7.06	0.33	0.84	± 12.0 %

<sup>c</sup> Frequency validity above 300 MHz of ± 100 MHz only applies for DASY v4.4 and higher (see Page 2), else it is restricted to ± 50 MHz. The uncertainty is the RSS of the ConvF uncertainty at calibration frequency and the uncertainty for the indicated frequency band. Frequency validity below 300 MHz is ± 10, 25, 40, 50 and 70 MHz for ConvF assessments at 30, 64, 128, 150 and 220 MHz respectively. Above 5 GHz frequency validity can be extended to ± 110 MHz.

<sup>f</sup> At frequencies below 3 GHz, the validity of tissue parameters ( $\epsilon$  and  $\sigma$ ) can be relaxed to ± 10% if liquid compensation formula is applied to measured SAR values. At frequencies above 3 GHz, the validity of tissue parameters ( $\epsilon$  and  $\sigma$ ) is restricted to ± 5%. The uncertainty is the RSS of the ConvF uncertainty for indicated target tissue parameters.

<sup>g</sup> Alpha/Depth are determined during calibration. SPEAG warrants that the remaining deviation due to the boundary effect after compensation is always less than ± 1% for frequencies below 3 GHz and below ± 2% for frequencies between 3-6 GHz at any distance larger than half the probe tip diameter from the boundary.

EX3DV4- SN:7329

February 5, 2015

**DASY/EASY - Parameters of Probe: EX3DV4 - SN:7329**

**Calibration Parameter Determined in Body Tissue Simulating Media**

f (MHz) <sup>C</sup>	Relative Permittivity <sup>F</sup>	Conductivity (S/m) <sup>F</sup>	ConvF X	ConvF Y	ConvF Z	Alpha <sup>G</sup>	Depth (mm) <sup>G</sup>	Unct. (k=2)
900	55.0	1.05	9.17	9.17	9.17	0.41	0.90	± 12.0 %
1750	53.4	1.49	7.85	7.85	7.85	0.70	0.64	± 12.0 %
1900	53.3	1.52	7.56	7.56	7.56	0.56	0.70	± 12.0 %
2450	52.7	1.95	7.20	7.20	7.20	0.78	0.59	± 12.0 %

<sup>C</sup> Frequency validity above 300 MHz of ± 100 MHz only applies for DASY v4.4 and higher (see Page 2), else it is restricted to ± 50 MHz. The uncertainty is the RSS of the ConvF uncertainty at calibration frequency and the uncertainty for the indicated frequency band. Frequency validity below 300 MHz is ± 10, 25, 40, 50 and 70 MHz for ConvF assessments at 30, 64, 128, 150 and 220 MHz respectively. Above 5 GHz frequency validity can be extended to ± 110 MHz.

<sup>F</sup> At frequencies below 3 GHz, the validity of tissue parameters (ε and σ) can be relaxed to ± 10% if liquid compensation formula is applied to measured SAR values. At frequencies above 3 GHz, the validity of tissue parameters (ε and σ) is restricted to ± 5%. The uncertainty is the RSS of the ConvF uncertainty for indicated target tissue parameters.

<sup>G</sup> Alpha/Depth are determined during calibration. SPEAG warrants that the remaining deviation due to the boundary effect after compensation is always less than ± 1% for frequencies below 3 GHz and below ± 2% for frequencies between 3-6 GHz at any distance larger than half the probe tip diameter from the boundary.

EX3DV4- SN:7329

February 5, 2015

### Frequency Response of E-Field (TEM-Cell: ifi110 EXX, Waveguide: R22)

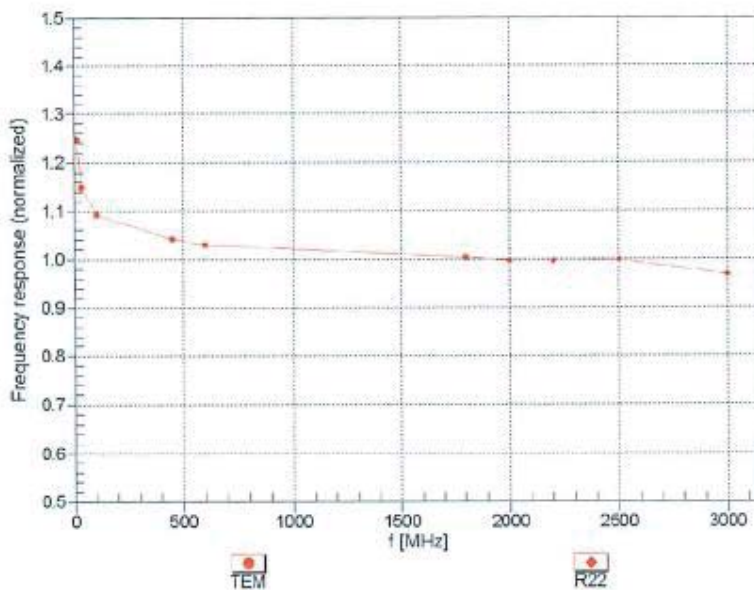

Uncertainty of Frequency Response of E-field:  $\pm 6.3\%$  (k=2)

EX3DV4-SN:7329

February 5, 2015

### Receiving Pattern ( $\phi$ ), $\theta = 0^\circ$

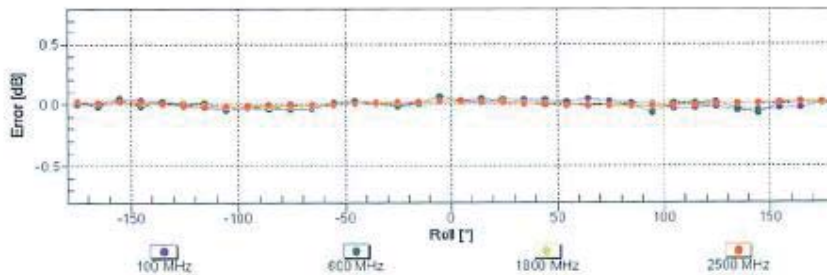
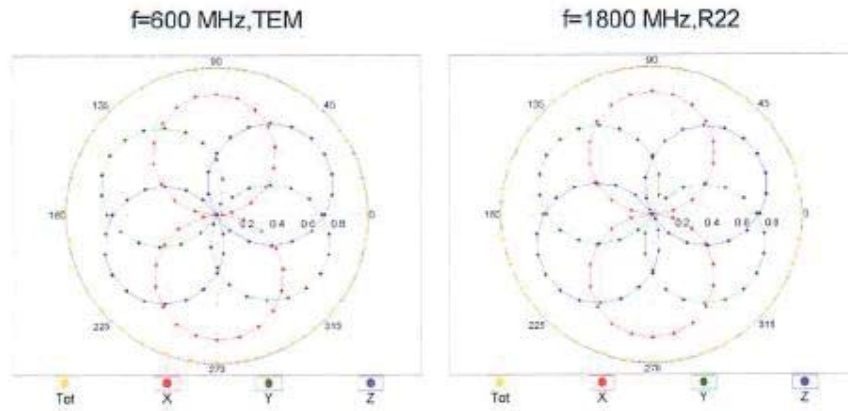

Uncertainty of Axial Isotropy Assessment:  $\pm 0.5\%$  ( $k=2$ )

EX3DV4- SN:7329

February 5, 2015

### Dynamic Range f(SAR<sub>head</sub>) (TEM cell , f<sub>eval</sub>= 1900 MHz)

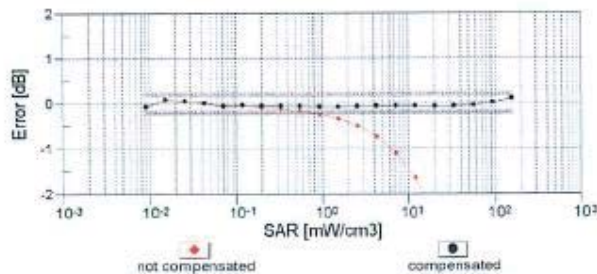
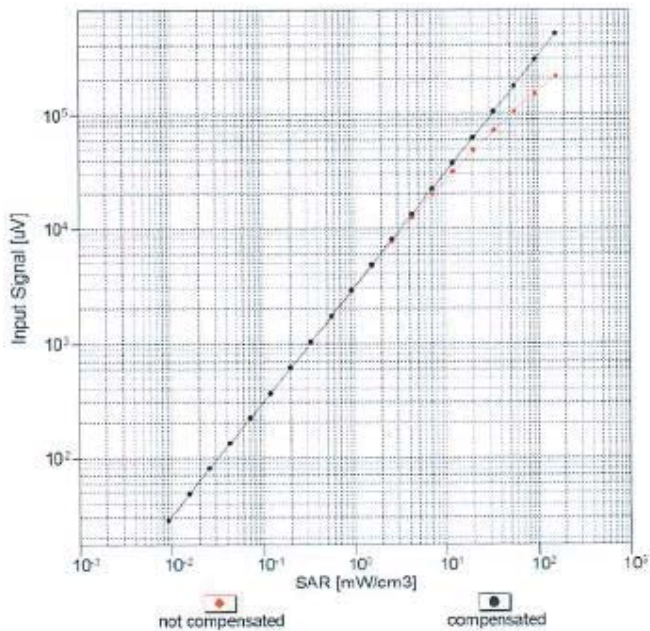

Uncertainty of Linearity Assessment: ± 0.6% (k=2)

EX3DV4- SN:7329

February 5, 2015

### Conversion Factor Assessment

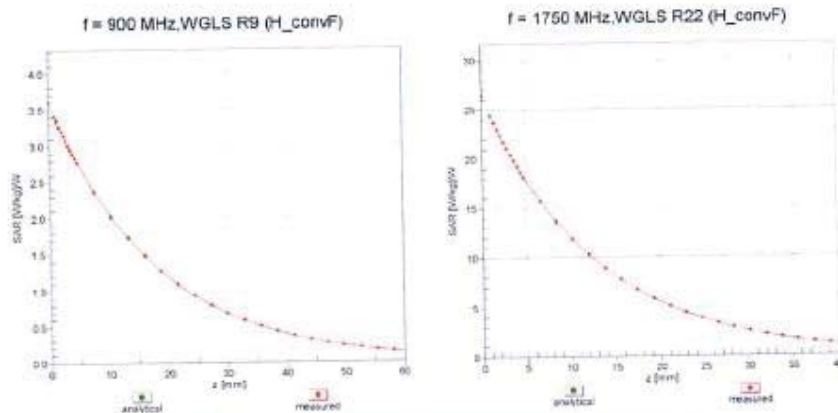

### Deviation from Isotropy in Liquid Error ( $\phi, \theta$ ), f = 900 MHz

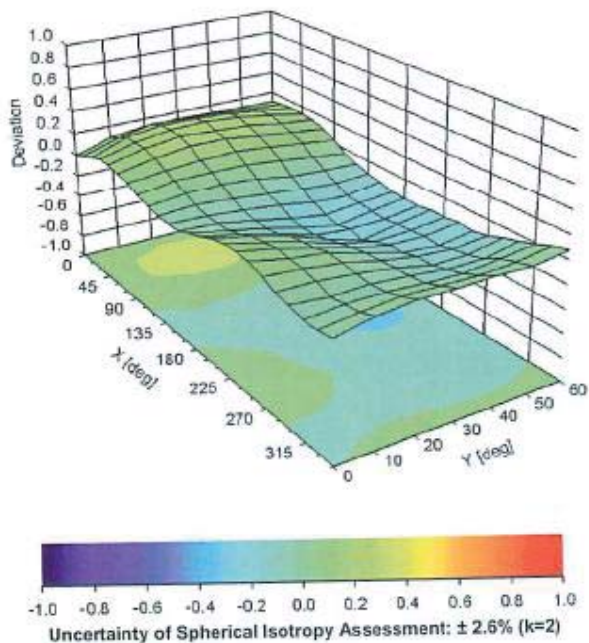

EX3DV4- SN:7329

February 5, 2015

**DASY/EASY - Parameters of Probe: EX3DV4 - SN:7329**

**Other Probe Parameters**

Sensor Arrangement	Triangular
Connector Angle (°)	24.5
Mechanical Surface Detection Mode	enabled
Optical Surface Detection Mode	disabled
Probe Overall Length	337 mm
Probe Body Diameter	10 mm
Tip Length	9 mm
Tip Diameter	2.5 mm
Probe Tip to Sensor X Calibration Point	1 mm
Probe Tip to Sensor Y Calibration Point	1 mm
Probe Tip to Sensor Z Calibration Point	1 mm
Recommended Measurement Distance from Surface	1.4 mm



# APPENDIX C DIPOLE CALIBRATION CERTIFICATES

**Calibration Laboratory of  
Schmid & Partner  
Engineering AG**  
Zeughausstrasse 43, 8004 Zurich, Switzerland



**S** Schweizerischer Kalibrierdienst  
**C** Service suisse d'étalonnage  
**S** Servizio svizzero di taratura  
**S** Swiss Calibration Service

Accredited by the Swiss Accreditation Service (SAS)  
The Swiss Accreditation Service is one of the signatories to the EA  
Multilateral Agreement for the recognition of calibration certificates

Accreditation No.: **SCS 0108**

Client **BACL**

Certificate No: **D835V2-453\_Aug15**

## CALIBRATION CERTIFICATE

Object: **D835V2 - SN: 453**

Calibration procedure(s): **QA CAL-05.v9  
Calibration procedure for dipole validation kits above 700 MHz**

Calibration date: **August 17, 2015**

This calibration certificate documents the traceability to national standards, which realize the physical units of measurements (SI).  
The measurements and the uncertainties with confidence probability are given on the following pages and are part of the certificate.

All calibrations have been conducted in the closed laboratory facility: environment temperature (22 ± 3)°C and humidity < 70%.

Calibration Equipment used (M&TE critical for calibration)

Primary Standards	ID #	Cal Date (Certificate No.)	Scheduled Calibration
Power meter EPM-442A	GB37480704	07-Oct-14 (No. 217-02020)	Oct-15
Power sensor HP 8481A	US37292783	07-Oct-14 (No. 217-02020)	Oct-15
Power sensor HP 8481A	MY41092317	07-Oct-14 (No. 217-02021)	Oct-15
Reference 20 dB Attenuator	SN: 5058 (20k)	01-Apr-15 (No. 217-02131)	Mar-16
Type-N mismatch combination	SN: 5047.2 / 06327	01-Apr-15 (No. 217-02134)	Mar-16
Reference Probe ES3DV3	SN: 3205	30-Dec-14 (No. ES3-3205_Dec14)	Dec-15
DAE4	SN: 654	08-Jul-15 (No. DAE4-654_Jul15)	Jul-16
Secondary Standards	ID #	Check Date (in house)	Scheduled Check
RF generator R&S SMT-06	100005	04-Aug-99 (in house check Oct-13)	In house check: Oct-16
Network Analyzer HP 8753E	US37390585 S4206	18-Oct-01 (in house check Oct-14)	In house check: Oct-15

Calibrated by: **Jeton Kastrati** (Name), **Laboratory Technician** (Function), [Signature]

Approved by: **Katja Pokovic** (Name), **Technical Manager** (Function), [Signature]

Issued: August 18, 2015

This calibration certificate shall not be reproduced except in full without written approval of the laboratory.



**Calibration Laboratory of  
Schmid & Partner  
Engineering AG**  
Zeughausstrasse 43, 8004 Zurich, Switzerland



**S** Schweizerischer Kalibrierdienst  
**C** Service suisse d'étalonnage  
**S** Servizio svizzero di taratura  
**S** Swiss Calibration Service

Accredited by the Swiss Accreditation Service (SAS)  
The Swiss Accreditation Service is one of the signatories to the EA  
Multilateral Agreement for the recognition of calibration certificates

Accreditation No.: **SCS 0108**

**Glossary:**

TSL tissue simulating liquid  
ConvF sensitivity in TSL / NORM x,y,z  
N/A not applicable or not measured

**Calibration is Performed According to the Following Standards:**

- a) IEEE Std 1528-2013, "IEEE Recommended Practice for Determining the Peak Spatial-Averaged Specific Absorption Rate (SAR) in the Human Head from Wireless Communications Devices: Measurement Techniques", June 2013
- b) IEC 62209-1, "Procedure to measure the Specific Absorption Rate (SAR) for hand-held devices used in close proximity to the ear (frequency range of 300 MHz to 3 GHz)", February 2005
- c) IEC 62209-2, "Procedure to determine the Specific Absorption Rate (SAR) for wireless communication devices used in close proximity to the human body (frequency range of 30 MHz to 6 GHz)", March 2010
- d) KDB 865664, "SAR Measurement Requirements for 100 MHz to 6 GHz"

**Additional Documentation:**

- e) DASY4/5 System Handbook

**Methods Applied and Interpretation of Parameters:**

- *Measurement Conditions:* Further details are available from the Validation Report at the end of the certificate. All figures stated in the certificate are valid at the frequency indicated.
- *Antenna Parameters with TSL:* The dipole is mounted with the spacer to position its feed point exactly below the center marking of the flat phantom section, with the arms oriented parallel to the body axis.
- *Feed Point Impedance and Return Loss:* These parameters are measured with the dipole positioned under the liquid filled phantom. The impedance stated is transformed from the measurement at the SMA connector to the feed point. The Return Loss ensures low reflected power. No uncertainty required.
- *Electrical Delay:* One-way delay between the SMA connector and the antenna feed point. No uncertainty required.
- *SAR measured:* SAR measured at the stated antenna input power.
- *SAR normalized:* SAR as measured, normalized to an input power of 1 W at the antenna connector.
- *SAR for nominal TSL parameters:* The measured TSL parameters are used to calculate the nominal SAR result.

The reported uncertainty of measurement is stated as the standard uncertainty of measurement multiplied by the coverage factor k=2, which for a normal distribution corresponds to a coverage probability of approximately 95%.

**Measurement Conditions**

DASY system configuration, as far as not given on page 1.

DASY Version	DASY5	V52.8.8
Extrapolation	Advanced Extrapolation	
Phantom	Modular Flat Phantom	
Distance Dipole Center - TSL	15 mm	with Spacer
Zoom Scan Resolution	dx, dy, dz = 5 mm	
Frequency	835 MHz ± 1 MHz	

**Head TSL parameters**

The following parameters and calculations were applied.

	Temperature	Permittivity	Conductivity
Nominal Head TSL parameters	22.0 °C	41.5	0.90 mho/m
Measured Head TSL parameters	(22.0 ± 0.2) °C	41.9 ± 6 %	0.93 mho/m ± 6 %
Head TSL temperature change during test	< 0.5 °C	----	----

**SAR result with Head TSL**

SAR averaged over 1 cm <sup>3</sup> (1 g) of Head TSL	Condition	
SAR measured	250 mW input power	2.41 W/kg
SAR for nominal Head TSL parameters	normalized to 1W	9.43 W/kg ± 17.0 % (k=2)

SAR averaged over 10 cm <sup>3</sup> (10 g) of Head TSL	condition	
SAR measured	250 mW input power	1.56 W/kg
SAR for nominal Head TSL parameters	normalized to 1W	6.13 W/kg ± 16.5 % (k=2)

**Body TSL parameters**

The following parameters and calculations were applied.

	Temperature	Permittivity	Conductivity
Nominal Body TSL parameters	22.0 °C	55.2	0.97 mho/m
Measured Body TSL parameters	(22.0 ± 0.2) °C	56.1 ± 6 %	1.02 mho/m ± 6 %
Body TSL temperature change during test	< 0.5 °C	----	----

**SAR result with Body TSL**

SAR averaged over 1 cm <sup>3</sup> (1 g) of Body TSL	Condition	
SAR measured	250 mW input power	2.47 W/kg
SAR for nominal Body TSL parameters	normalized to 1W	9.55 W/kg ± 17.0 % (k=2)

SAR averaged over 10 cm <sup>3</sup> (10 g) of Body TSL	condition	
SAR measured	250 mW input power	1.61 W/kg
SAR for nominal Body TSL parameters	normalized to 1W	6.27 W/kg ± 16.5 % (k=2)

**Appendix (Additional assessments outside the scope of SCS 0108)**

**Antenna Parameters with Head TSL**

Impedance, transformed to feed point	50.7 Ω - 4.6 jΩ
Return Loss	- 26.8 dB

**Antenna Parameters with Body TSL**

Impedance, transformed to feed point	46.8 Ω - 6.0 jΩ
Return Loss	- 23.1 dB

**General Antenna Parameters and Design**

Electrical Delay (one direction)	1.392 ns
----------------------------------	----------

After long term use with 100W radiated power, only a slight warming of the dipole near the feedpoint can be measured.

The dipole is made of standard semirigid coaxial cable. The center conductor of the feeding line is directly connected to the second arm of the dipole. The antenna is therefore short-circuited for DC-signals. On some of the dipoles, small end caps are added to the dipole arms in order to improve matching when loaded according to the position as explained in the "Measurement Conditions" paragraph. The SAR data are not affected by this change. The overall dipole length is still according to the Standard.

No excessive force must be applied to the dipole arms, because they might bend or the soldered connections near the feedpoint may be damaged.

**Additional EUT Data**

Manufactured by	SPEAG
Manufactured on	January 31, 2002

**DASY5 Validation Report for Head TSL**

Date: 17.08.2015

Test Laboratory: SPEAG, Zurich, Switzerland

**DUT: Dipole 835 MHz; Type: D835V2; Serial: D835V2 - SN: 453**

Communication System: UID 0 - CW; Frequency: 835 MHz

Medium parameters used:  $f = 835$  MHz;  $\sigma = 0.93$  S/m;  $\epsilon_r = 41.9$ ;  $\rho = 1000$  kg/m<sup>3</sup>

Phantom section: Flat Section

Measurement Standard: DASY5 (IEEE/IEC/ANSI C63.19-2011)

DASY52 Configuration:

- Probe: ES3DV3 - SN3205; ConvF(6.2, 6.2, 6.2); Calibrated: 30.12.2014;
- Sensor-Surface: 3mm (Mechanical Surface Detection)
- Electronics: DAE4 Sn654; Calibrated: 08.07.2015
- Phantom: Flat Phantom 4.9L; Type: QD000P49AA; Serial: 1001
- DASY52 52.8.8(1222); SEMCAD X 14.6.10(7331)

**Dipole Calibration for Head Tissue/Pin=250 mW, d=15mm/Zoom Scan (7x7x7)/Cube 0:**

Measurement grid: dx=5mm, dy=5mm, dz=5mm

Reference Value = 58.20 V/m; Power Drift = -0.06 dB

Peak SAR (extrapolated) = 3.65 W/kg

**SAR(1 g) = 2.41 W/kg; SAR(10 g) = 1.56 W/kg**

Maximum value of SAR (measured) = 2.84 W/kg

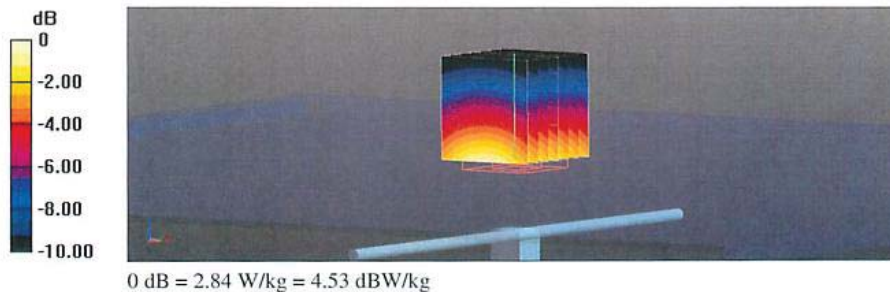

### Impedance Measurement Plot for Head TSL

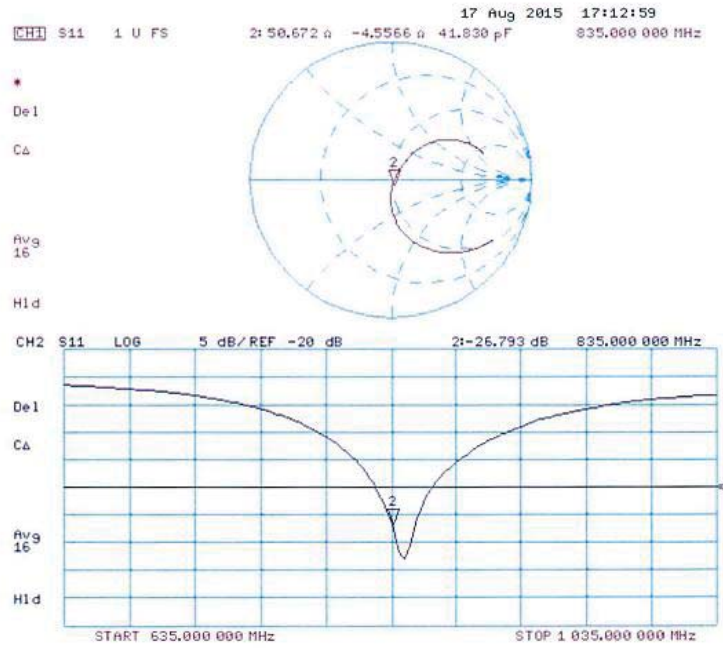



**DASY5 Validation Report for Body TSL**

Date: 17.08.2015

Test Laboratory: SPEAG, Zurich, Switzerland

**DUT: Dipole 835 MHz; Type: D835V2; Serial: D835V2 - SN: 453**

Communication System: UID 0 - CW; Frequency: 835 MHz  
Medium parameters used:  $f = 835$  MHz;  $\sigma = 1.02$  S/m;  $\epsilon_r = 56.1$ ;  $\rho = 1000$  kg/m<sup>3</sup>  
Phantom section: Flat Section  
Measurement Standard: DASY5 (IEEE/IEC/ANSI C63.19-2011)

**DASY52 Configuration:**

- Probe: ES3DV3 - SN3205; ConvF(6.17, 6.17, 6.17); Calibrated: 30.12.2014;
- Sensor-Surface: 3mm (Mechanical Surface Detection)
- Electronics: DAE4 Sn654; Calibrated: 08.07.2015
- Phantom: Flat Phantom 4.9L; Type: QD000P49AA; Serial: 1001
- DASY52 52.8.8(1222); SEMCAD X 14.6.10(7331)

**Dipole Calibration for Body Tissue/Pin=250 mW, d=15mm/Zoom Scan (7x7x7)/Cube 0:**

Measurement grid: dx=5mm, dy=5mm, dz=5mm  
Reference Value = 55.00 V/m; Power Drift = 0.01 dB  
Peak SAR (extrapolated) = 3.69 W/kg  
**SAR(1 g) = 2.47 W/kg; SAR(10 g) = 1.61 W/kg**  
Maximum value of SAR (measured) = 2.89 W/kg

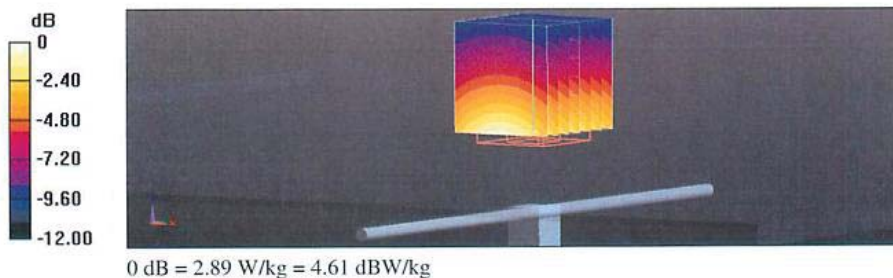

### Impedance Measurement Plot for Body TSL

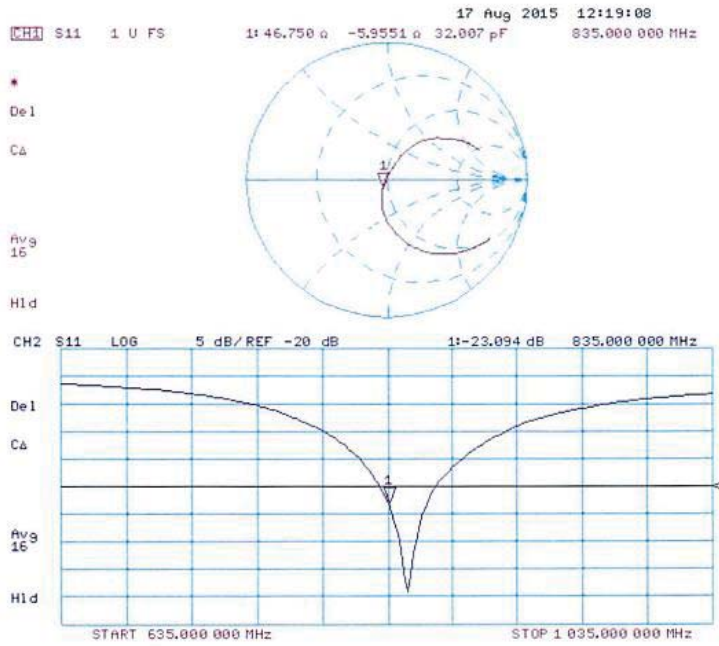

**Calibration Laboratory of  
Schmid & Partner  
Engineering AG**  
Zeughausstrasse 43, 8004 Zurich, Switzerland



**S** Schweizerischer Kalibrierdienst  
**C** Service suisse d'étalonnage  
**S** Servizio svizzero di taratura  
**S** Swiss Calibration Service

Accredited by the Swiss Accreditation Service (SAS)  
The Swiss Accreditation Service is one of the signatories to the EA  
Multilateral Agreement for the recognition of calibration certificates

Accreditation No.: **SCS 0108**

Client **BACL**

Certificate No: **D1750V2-1141\_Jul15**

**CALIBRATION CERTIFICATE**

Object: **D1750V2 - SN:1141**

Calibration procedure(s): **QA CAL-05.v9  
Calibration procedure for dipole validation kits above 700 MHz**

Calibration date: **July 09, 2015**

This calibration certificate documents the traceability to national standards, which realize the physical units of measurements (SI).  
The measurements and the uncertainties with confidence probability are given on the following pages and are part of the certificate.

All calibrations have been conducted in the closed laboratory facility: environment temperature (22 ± 3)°C and humidity < 70%.

Calibration Equipment used (M&TE critical for calibration)

Primary Standards	ID #	Cal Date (Certificate No.)	Scheduled Calibration
Power meter EPM-442A	GB37480704	07-Oct-14 (No. 217-02020)	Oct-15
Power sensor HP 8481A	US37292783	07-Oct-14 (No. 217-02020)	Oct-15
Power sensor HP 8481A	MY41092317	07-Oct-14 (No. 217-02021)	Oct-15
Reference 20 dB Attenuator	SN: 5058 (20k)	01-Apr-15 (No. 217-02131)	Mar-16
Type-N mismatch combination	SN: 5047.2 / 06327	01-Apr-15 (No. 217-02134)	Mar-16
Reference Probe ES3DV3	SN: 3205	30-Dec-14 (No. ES3-3205_Dec14)	Dec-15
DAE4	SN: 601	18-Aug-14 (No. DAE4-601_Aug14)	Aug-15
Secondary Standards	ID #	Check Date (in house)	Scheduled Check
RF generator R&S SMT-06	100005	04-Aug-99 (in house check Oct-13)	In house check: Oct-16
Network Analyzer HP 8753E	US37390585 S4206	18-Oct-01 (in house check Oct-14)	In house check: Oct-15

Calibrated by: **Name: Claudio Leubler, Function: Laboratory Technician, Signature: [Signature]**

Approved by: **Name: Katja Pokovic, Function: Technical Manager, Signature: [Signature]**

Issued: July 14, 2015

This calibration certificate shall not be reproduced except in full without written approval of the laboratory.



**Calibration Laboratory of**  
 Schmid & Partner  
 Engineering AG  
 Zeughausstrasse 43, 8004 Zurich, Switzerland



**S** Schweizerischer Kalibrierdienst  
**C** Service suisse d'étalonnage  
**S** Servizio svizzero di taratura  
**S** Swiss Calibration Service

Accredited by the Swiss Accreditation Service (SAS)  
 The Swiss Accreditation Service is one of the signatories to the EA  
 Multilateral Agreement for the recognition of calibration certificates

Accreditation No.: **SCS 0108**

**Glossary:**

TSL tissue simulating liquid  
 ConvF sensitivity in TSL / NORM x,y,z  
 N/A not applicable or not measured

**Calibration is Performed According to the Following Standards:**

- a) IEEE Std 1528-2013, "IEEE Recommended Practice for Determining the Peak Spatial-Averaged Specific Absorption Rate (SAR) in the Human Head from Wireless Communications Devices: Measurement Techniques", June 2013
- b) IEC 62209-1, "Procedure to measure the Specific Absorption Rate (SAR) for hand-held devices used in close proximity to the ear (frequency range of 300 MHz to 3 GHz)", February 2005
- c) IEC 62209-2, "Procedure to determine the Specific Absorption Rate (SAR) for wireless communication devices used in close proximity to the human body (frequency range of 30 MHz to 6 GHz)", March 2010
- d) KDB 865664, "SAR Measurement Requirements for 100 MHz to 6 GHz"

**Additional Documentation:**

- e) DASY4/5 System Handbook

**Methods Applied and Interpretation of Parameters:**

- *Measurement Conditions:* Further details are available from the Validation Report at the end of the certificate. All figures stated in the certificate are valid at the frequency indicated.
- *Antenna Parameters with TSL:* The dipole is mounted with the spacer to position its feed point exactly below the center marking of the flat phantom section, with the arms oriented parallel to the body axis.
- *Feed Point Impedance and Return Loss:* These parameters are measured with the dipole positioned under the liquid filled phantom. The impedance stated is transformed from the measurement at the SMA connector to the feed point. The Return Loss ensures low reflected power. No uncertainty required.
- *Electrical Delay:* One-way delay between the SMA connector and the antenna feed point. No uncertainty required.
- *SAR measured:* SAR measured at the stated antenna input power.
- *SAR normalized:* SAR as measured, normalized to an input power of 1 W at the antenna connector.
- *SAR for nominal TSL parameters:* The measured TSL parameters are used to calculate the nominal SAR result.

The reported uncertainty of measurement is stated as the standard uncertainty of measurement multiplied by the coverage factor k=2, which for a normal distribution corresponds to a coverage probability of approximately 95%.

**Measurement Conditions**

DASY system configuration, as far as not given on page 1.

DASY Version	DASY5	V52.8.8
Extrapolation	Advanced Extrapolation	
Phantom	Modular Flat Phantom	
Distance Dipole Center - TSL	10 mm	with Spacer
Zoom Scan Resolution	dx, dy, dz = 5 mm	
Frequency	1750 MHz ± 1 MHz	

**Head TSL parameters**

The following parameters and calculations were applied.

	Temperature	Permittivity	Conductivity
Nominal Head TSL parameters	22.0 °C	40.1	1.37 mho/m
Measured Head TSL parameters	(22.0 ± 0.2) °C	38.8 ± 6 %	1.38 mho/m ± 6 %
Head TSL temperature change during test	< 0.5 °C	----	----

**SAR result with Head TSL**

SAR averaged over 1 cm <sup>3</sup> (1 g) of Head TSL	Condition	
SAR measured	250 mW input power	9.31 W/kg
SAR for nominal Head TSL parameters	normalized to 1W	36.8 W/kg ± 17.0 % (k=2)

SAR averaged over 10 cm <sup>3</sup> (10 g) of Head TSL	condition	
SAR measured	250 mW input power	4.97 W/kg
SAR for nominal Head TSL parameters	normalized to 1W	19.7 W/kg ± 16.5 % (k=2)

**Body TSL parameters**

The following parameters and calculations were applied.

	Temperature	Permittivity	Conductivity
Nominal Body TSL parameters	22.0 °C	53.4	1.49 mho/m
Measured Body TSL parameters	(22.0 ± 0.2) °C	52.2 ± 6 %	1.48 mho/m ± 6 %
Body TSL temperature change during test	< 0.5 °C	----	----

**SAR result with Body TSL**

SAR averaged over 1 cm <sup>3</sup> (1 g) of Body TSL	Condition	
SAR measured	250 mW input power	9.37 W/kg
SAR for nominal Body TSL parameters	normalized to 1W	37.4 W/kg ± 17.0 % (k=2)

SAR averaged over 10 cm <sup>3</sup> (10 g) of Body TSL	condition	
SAR measured	250 mW input power	5.07 W/kg
SAR for nominal Body TSL parameters	normalized to 1W	20.3 W/kg ± 16.5 % (k=2)

**Appendix (Additional assessments outside the scope of SCS 0108)**

**Antenna Parameters with Head TSL**

Impedance, transformed to feed point	51.1 $\Omega$ - 0.1 j $\Omega$
Return Loss	- 39.5 dB

**Antenna Parameters with Body TSL**

Impedance, transformed to feed point	46.6 $\Omega$ + 0.3 j $\Omega$
Return Loss	- 29.0 dB

**General Antenna Parameters and Design**

Electrical Delay (one direction)	1.225 ns
----------------------------------	----------

After long term use with 100W radiated power, only a slight warming of the dipole near the feedpoint can be measured.

The dipole is made of standard semirigid coaxial cable. The center conductor of the feeding line is directly connected to the second arm of the dipole. The antenna is therefore short-circuited for DC-signals. On some of the dipoles, small end caps are added to the dipole arms in order to improve matching when loaded according to the position as explained in the "Measurement Conditions" paragraph. The SAR data are not affected by this change. The overall dipole length is still according to the Standard.

No excessive force must be applied to the dipole arms, because they might bend or the soldered connections near the feedpoint may be damaged.

**Additional EUT Data**

Manufactured by	SPEAG
Manufactured on	September 30, 2014

**DASY5 Validation Report for Head TSL**

Date: 09.07.2015

Test Laboratory: SPEAG, Zurich, Switzerland

**DUT: Dipole 1750 MHz; Type: D1750V2; Serial: D1750V2 - SN:1141**

Communication System: UID 0 - CW; Frequency: 1750 MHz  
Medium parameters used:  $f = 1750$  MHz;  $\sigma = 1.38$  S/m;  $\epsilon_r = 38.8$ ;  $\rho = 1000$  kg/m<sup>3</sup>  
Phantom section: Flat Section  
Measurement Standard: DASY5 (IEEE/IEC/ANSI C63.19-2011)

DASY52 Configuration:

- Probe: ES3DV3 - SN3205; ConvF(5.2, 5.2, 5.2); Calibrated: 30.12.2014;
- Sensor-Surface: 3mm (Mechanical Surface Detection)
- Electronics: DAE4 Sn601; Calibrated: 18.08.2014
- Phantom: Flat Phantom 5.0 (front); Type: QD000P50AA; Serial: 1001
- DASY52 52.8.8(1222); SEMCAD X 14.6.10(7331)

**Dipole Calibration for Head Tissue/Pin=250 mW, d=10mm/Zoom Scan (7x7x7)/Cube 0:**

Measurement grid: dx=5mm, dy=5mm, dz=5mm  
Reference Value = 93.34 V/m; Power Drift = 0.04 dB  
Peak SAR (extrapolated) = 16.6 W/kg  
**SAR(1 g) = 9.31 W/kg; SAR(10 g) = 4.97 W/kg**  
Maximum value of SAR (measured) = 11.3 W/kg

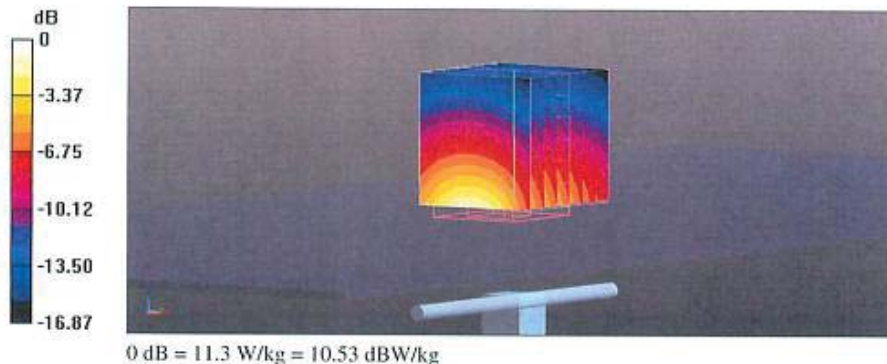

### Impedance Measurement Plot for Head TSL

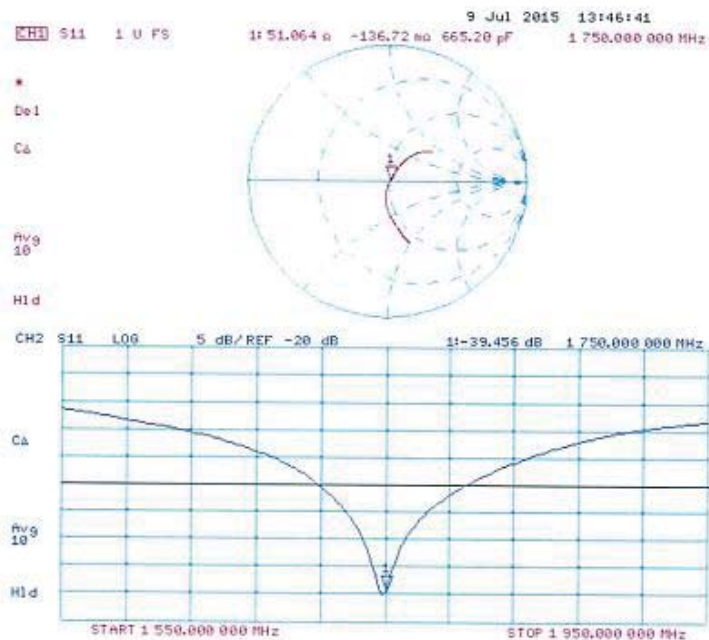



**DASY5 Validation Report for Body TSL**

Date: 09.07.2015

Test Laboratory: SPEAG, Zurich, Switzerland

**DUT: Dipole 1750 MHz; Type: D1750V2; Serial: D1750V2 - SN:1141**

Communication System: UID 0 - CW; Frequency: 1750 MHz

Medium parameters used:  $f = 1750 \text{ MHz}$ ;  $\sigma = 1.48 \text{ S/m}$ ;  $\epsilon_r = 52.2$ ;  $\rho = 1000 \text{ kg/m}^3$

Phantom section: Flat Section

Measurement Standard: DASY5 (IEEE/IEC/ANSI C63.19-2011)

DASY52 Configuration:

- Probe: ES3DV3 - SN3205; ConvF(4.88, 4.88, 4.88); Calibrated: 30.12.2014;
- Sensor-Surface: 3mm (Mechanical Surface Detection)
- Electronics: DAE4 Sn601; Calibrated: 18.08.2014
- Phantom: Flat Phantom 5.0 (back); Type: QD000P50AA; Serial: 1002
- DASY52 52.8.8(1222); SEMCAD X 14.6.10(7331)

**Dipole Calibration for Body Tissue/Pin=250 mW, d=10mm/Zoom Scan (7x7x7)/Cube 0:**

Measurement grid: dx=5mm, dy=5mm, dz=5mm

Reference Value = 92.95 V/m; Power Drift = 0.02 dB

Peak SAR (extrapolated) = 15.9 W/kg

**SAR(1 g) = 9.37 W/kg; SAR(10 g) = 5.07 W/kg**

Maximum value of SAR (measured) = 11.8 W/kg

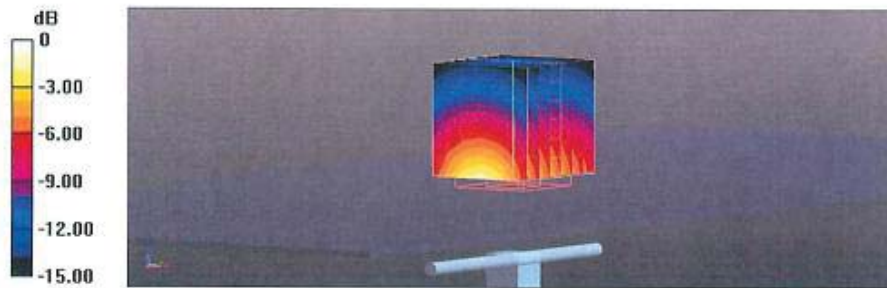

### Impedance Measurement Plot for Body TSL

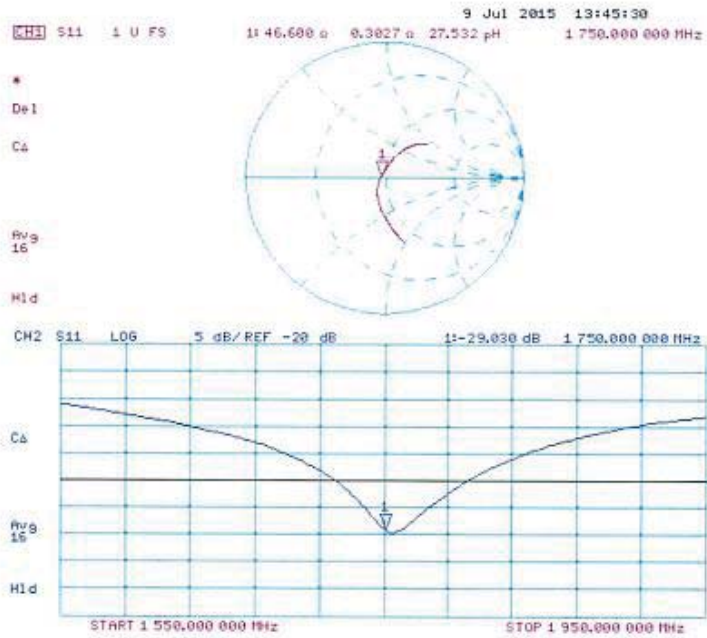

**Calibration Laboratory of  
Schmid & Partner  
Engineering AG**  
Zeughausstrasse 43, 8004 Zurich, Switzerland



**S** Schweizerischer Kalibrierdienst  
**C** Service suisse d'étalonnage  
**S** Servizio svizzero di taratura  
**S** Swiss Calibration Service

Accredited by the Swiss Accreditation Service (SAS)  
The Swiss Accreditation Service is one of the signatories to the EA  
Multilateral Agreement for the recognition of calibration certificates

Accreditation No.: **SCS 0108**

Client **BACL**

Certificate No: **D1900V2-5d206\_Jul15**

**CALIBRATION CERTIFICATE**

Object **D1900V2 - SN:5d206**

Calibration procedure(s) **QA CAL-05.v9  
Calibration procedure for dipole validation kits above 700 MHz**

Calibration date: **July 14, 2015**

This calibration certificate documents the traceability to national standards, which realize the physical units of measurements (SI).  
The measurements and the uncertainties with confidence probability are given on the following pages and are part of the certificate.

All calibrations have been conducted in the closed laboratory facility; environment temperature (22 ± 3)°C and humidity < 70%.

Calibration Equipment used (M&TE critical for calibration)

Primary Standards	ID #	Cal Date (Certificate No.)	Scheduled Calibration
Power meter EPM-442A	GB37480704	07-Oct-14 (No. 217-02020)	Oct-15
Power sensor HP 8481A	US37292783	07-Oct-14 (No. 217-02020)	Oct-15
Power sensor HP 8481A	MY41092317	07-Oct-14 (No. 217-02021)	Oct-15
Reference 20 dB Attenuator	SN: 5058 (20k)	01-Apr-15 (No. 217-02131)	Mar-16
Type-N mismatch combination	SN: 5047.2 / 06327	01-Apr-15 (No. 217-02134)	Mar-16
Reference Probe ES3DV3	SN: 3205	30-Dec-14 (No. ES3-3205_Dec14)	Dec-15
DAE4	SN: 601	18-Aug-14 (No. DAE4-601_Aug14)	Aug-15
Secondary Standards	ID #	Check Date (in house)	Scheduled Check
RF generator R&S SMT-06	100005	04-Aug-99 (in house check Oct-13)	In house check: Oct-16
Network Analyzer HP 8753E	US37390585 S4206	18-Oct-01 (in house check Oct-14)	In house check: Oct-15

Calibrated by:	Name <b>Leif Klynsner</b>	Function Laboratory Technician	Signature 
Approved by:	Name <b>Katja Pokovic</b>	Function Technical Manager	Signature 

Issued: July 14, 2015

This calibration certificate shall not be reproduced except in full without written approval of the laboratory.



**Calibration Laboratory of  
Schmid & Partner  
Engineering AG**  
Zeughausstrasse 43, 8004 Zurich, Switzerland



**S** Schweizerischer Kalibrierdienst  
**C** Service suisse d'étalonnage  
**S** Servizio svizzero di taratura  
**S** Swiss Calibration Service

Accredited by the Swiss Accreditation Service (SAS)  
The Swiss Accreditation Service is one of the signatories to the EA  
Multilateral Agreement for the recognition of calibration certificates

Accreditation No.: **SCS 0108**

**Glossary:**

TSL tissue simulating liquid  
ConvF sensitivity in TSL / NORM x,y,z  
N/A not applicable or not measured

**Calibration is Performed According to the Following Standards:**

- a) IEEE Std 1528-2013, "IEEE Recommended Practice for Determining the Peak Spatial-Averaged Specific Absorption Rate (SAR) in the Human Head from Wireless Communications Devices: Measurement Techniques", June 2013
- b) IEC 62209-1, "Procedure to measure the Specific Absorption Rate (SAR) for hand-held devices used in close proximity to the ear (frequency range of 300 MHz to 3 GHz)", February 2005
- c) IEC 62209-2, "Procedure to determine the Specific Absorption Rate (SAR) for wireless communication devices used in close proximity to the human body (frequency range of 30 MHz to 6 GHz)", March 2010
- d) KDB 865664, "SAR Measurement Requirements for 100 MHz to 6 GHz"

**Additional Documentation:**

- e) DASY4/5 System Handbook

**Methods Applied and Interpretation of Parameters:**

- *Measurement Conditions:* Further details are available from the Validation Report at the end of the certificate. All figures stated in the certificate are valid at the frequency indicated.
- *Antenna Parameters with TSL:* The dipole is mounted with the spacer to position its feed point exactly below the center marking of the flat phantom section, with the arms oriented parallel to the body axis.
- *Feed Point Impedance and Return Loss:* These parameters are measured with the dipole positioned under the liquid filled phantom. The impedance stated is transformed from the measurement at the SMA connector to the feed point. The Return Loss ensures low reflected power. No uncertainty required.
- *Electrical Delay:* One-way delay between the SMA connector and the antenna feed point. No uncertainty required.
- *SAR measured:* SAR measured at the stated antenna input power.
- *SAR normalized:* SAR as measured, normalized to an input power of 1 W at the antenna connector.
- *SAR for nominal TSL parameters:* The measured TSL parameters are used to calculate the nominal SAR result.

The reported uncertainty of measurement is stated as the standard uncertainty of measurement multiplied by the coverage factor k=2, which for a normal distribution corresponds to a coverage probability of approximately 95%.

**Measurement Conditions**

DASY system configuration, as far as not given on page 1.

DASY Version	DASY5	V52.8.8
Extrapolation	Advanced Extrapolation	
Phantom	Modular Flat Phantom	
Distance Dipole Center - TSL	10 mm	with Spacer
Zoom Scan Resolution	dx, dy, dz = 5 mm	
Frequency	1900 MHz ± 1 MHz	

**Head TSL parameters**

The following parameters and calculations were applied.

	Temperature	Permittivity	Conductivity
Nominal Head TSL parameters	22.0 °C	40.0	1.40 mho/m
Measured Head TSL parameters	(22.0 ± 0.2) °C	39.7 ± 6 %	1.38 mho/m ± 6 %
Head TSL temperature change during test	< 0.5 °C	----	----

**SAR result with Head TSL**

SAR averaged over 1 cm <sup>3</sup> (1 g) of Head TSL	Condition	
SAR measured	250 mW input power	10.1 W/kg
SAR for nominal Head TSL parameters	normalized to 1W	40.7 W/kg ± 17.0 % (k=2)

SAR averaged over 10 cm <sup>3</sup> (10 g) of Head TSL	condition	
SAR measured	250 mW input power	5.35 W/kg
SAR for nominal Head TSL parameters	normalized to 1W	21.5 W/kg ± 16.5 % (k=2)

**Body TSL parameters**

The following parameters and calculations were applied.

	Temperature	Permittivity	Conductivity
Nominal Body TSL parameters	22.0 °C	53.3	1.52 mho/m
Measured Body TSL parameters	(22.0 ± 0.2) °C	52.7 ± 6 %	1.54 mho/m ± 6 %
Body TSL temperature change during test	< 0.5 °C	----	----

**SAR result with Body TSL**

SAR averaged over 1 cm <sup>3</sup> (1 g) of Body TSL	Condition	
SAR measured	250 mW input power	10.3 W/kg
SAR for nominal Body TSL parameters	normalized to 1W	40.8 W/kg ± 17.0 % (k=2)

SAR averaged over 10 cm <sup>3</sup> (10 g) of Body TSL	condition	
SAR measured	250 mW input power	5.51 W/kg
SAR for nominal Body TSL parameters	normalized to 1W	21.9 W/kg ± 16.5 % (k=2)

**Appendix (Additional assessments outside the scope of SCS 0108)**

**Antenna Parameters with Head TSL**

Impedance, transformed to feed point	52.5 Ω + 6.5 jΩ
Return Loss	- 23.3 dB

**Antenna Parameters with Body TSL**

Impedance, transformed to feed point	48.6 Ω + 7.1 jΩ
Return Loss	- 22.8 dB

**General Antenna Parameters and Design**

Electrical Delay (one direction)	1.203 ns
----------------------------------	----------

After long term use with 100W radiated power, only a slight warming of the dipole near the feedpoint can be measured.

The dipole is made of standard semirigid coaxial cable. The center conductor of the feeding line is directly connected to the second arm of the dipole. The antenna is therefore short-circuited for DC-signals. On some of the dipoles, small end caps are added to the dipole arms in order to improve matching when loaded according to the position as explained in the "Measurement Conditions" paragraph. The SAR data are not affected by this change. The overall dipole length is still according to the Standard.

No excessive force must be applied to the dipole arms, because they might bend or the soldered connections near the feedpoint may be damaged.

**Additional EUT Data**

Manufactured by	SPEAG
Manufactured on	October 21, 2014

**DASY5 Validation Report for Head TSL**

Date: 14.07.2015

Test Laboratory: SPEAG, Zurich, Switzerland

**DUT: Dipole 1900 MHz; Type: D1900V2; Serial: D1900V2 - SN:5d206**

Communication System: UID 0 - CW; Frequency: 1900 MHz  
Medium parameters used:  $f = 1900$  MHz;  $\sigma = 1.38$  S/m;  $\epsilon_r = 39.7$ ;  $\rho = 1000$  kg/m<sup>3</sup>  
Phantom section: Flat Section  
Measurement Standard: DASY5 (IEEE/IEC/ANSI C63.19-2011)

**DASY52 Configuration:**

- Probe: ES3DV3 - SN3205; ConvF(5, 5, 5); Calibrated: 30.12.2014;
- Sensor-Surface: 3mm (Mechanical Surface Detection)
- Electronics: DAE4 Sn601; Calibrated: 18.08.2014
- Phantom: Flat Phantom 5.0 (front); Type: QD000P50AA; Serial: 1001
- DASY52 52.8.8(1222); SEMCAD X 14.6.10(7331)

**Dipole Calibration for Head Tissue/Pin=250 mW, d=10mm/Zoom Scan (7x7x7)/Cube 0:**

Measurement grid: dx=5mm, dy=5mm, dz=5mm  
Reference Value = 99.02 V/m; Power Drift = 0.02 dB  
Peak SAR (extrapolated) = 18.4 W/kg  
**SAR(1 g) = 10.1 W/kg; SAR(10 g) = 5.35 W/kg**  
Maximum value of SAR (measured) = 12.8 W/kg

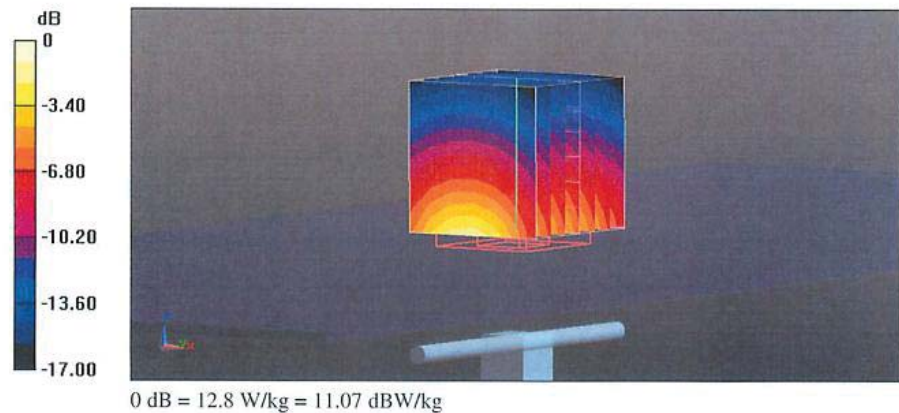

### Impedance Measurement Plot for Head TSL

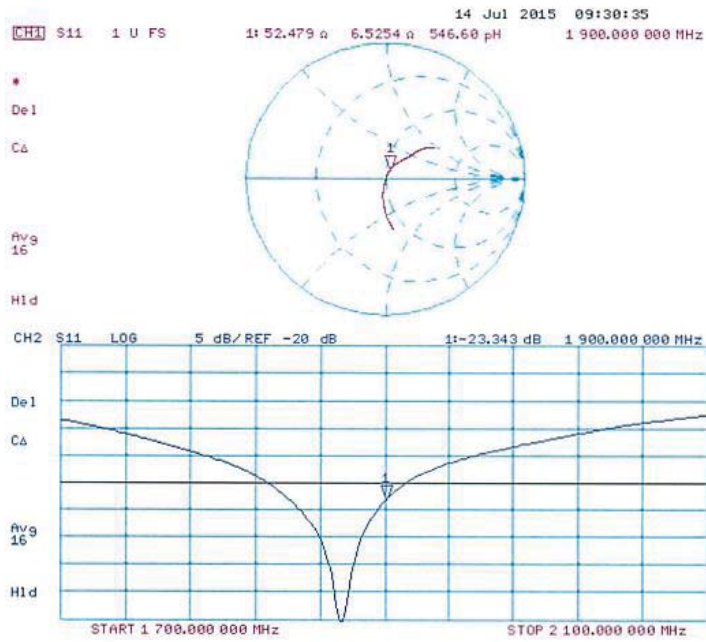



**DASY5 Validation Report for Body TSL**

Date: 14.07.2015

Test Laboratory: SPEAG, Zurich, Switzerland

**DUT: Dipole 1900 MHz; Type: D1900V2; Serial: D1900V2 - SN:5d206**

Communication System: UID 0 - CW; Frequency: 1900 MHz  
Medium parameters used:  $f = 1900$  MHz;  $\sigma = 1.54$  S/m;  $\epsilon_r = 52.7$ ;  $\rho = 1000$  kg/m<sup>3</sup>  
Phantom section: Flat Section  
Measurement Standard: DASY5 (IEEE/IEC/ANSI C63.19-2011)

DASY52 Configuration:

- Probe: ES3DV3 - SN3205; ConvF(4.65, 4.65, 4.65); Calibrated: 30.12.2014;
- Sensor-Surface: 3mm (Mechanical Surface Detection)
- Electronics: DAE4 Sn601; Calibrated: 18.08.2014
- Phantom: Flat Phantom 5.0 (back); Type: QD000P50AA; Serial: 1002
- DASY52 52.8.8(1222); SEMCAD X 14.6.10(7331)

**Dipole Calibration for Body Tissue/Pin=250 mW, d=10mm/Zoom Scan (7x7x7)/Cube 0:**

Measurement grid: dx=5mm, dy=5mm, dz=5mm  
Reference Value = 95.62 V/m; Power Drift = 0.02 dB  
Peak SAR (extrapolated) = 17.3 W/kg  
**SAR(1 g) = 10.3 W/kg; SAR(10 g) = 5.51 W/kg**  
Maximum value of SAR (measured) = 12.9 W/kg

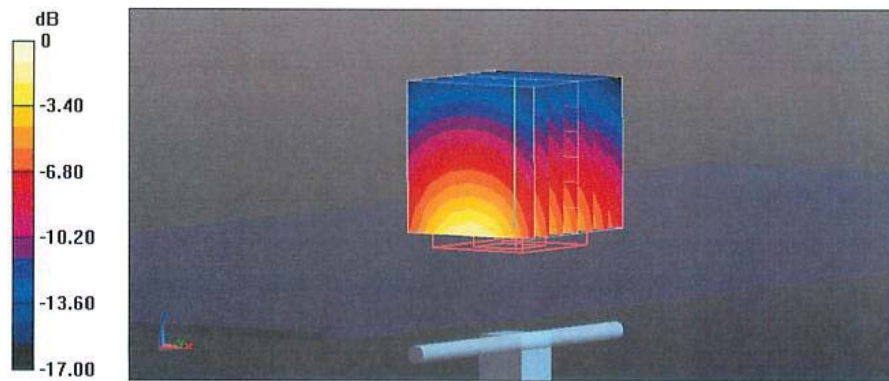

0 dB = 12.9 W/kg = 11.11 dBW/kg

### Impedance Measurement Plot for Body TSL

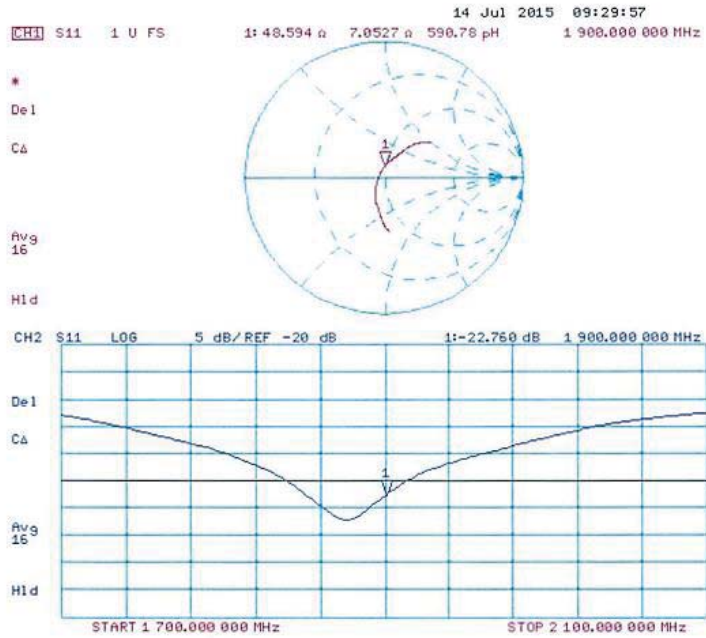

## APPENDIX D EUT TEST POSITION PHOTOS

Liquid depth  $\geq 15\text{cm}$



Left Head Cheek

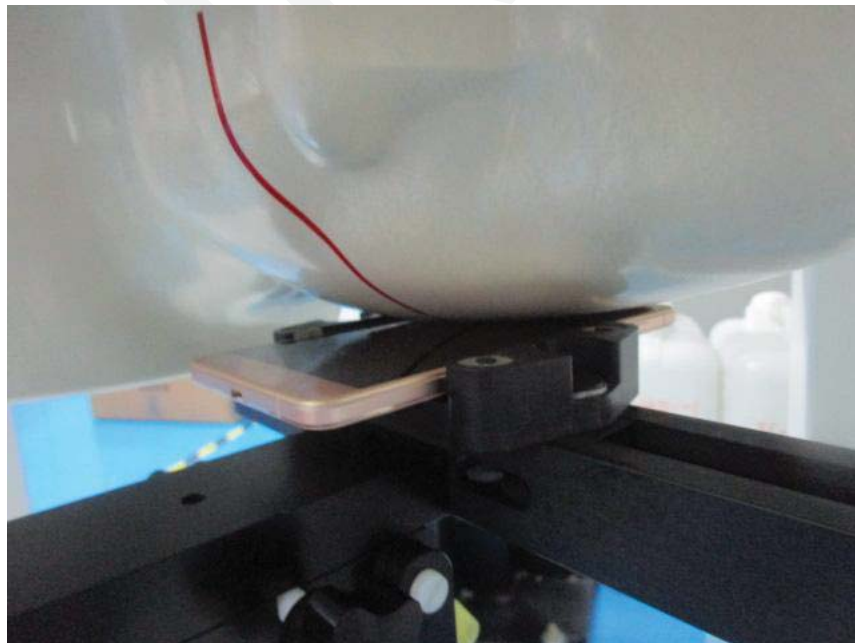



**Left Head Tilt**

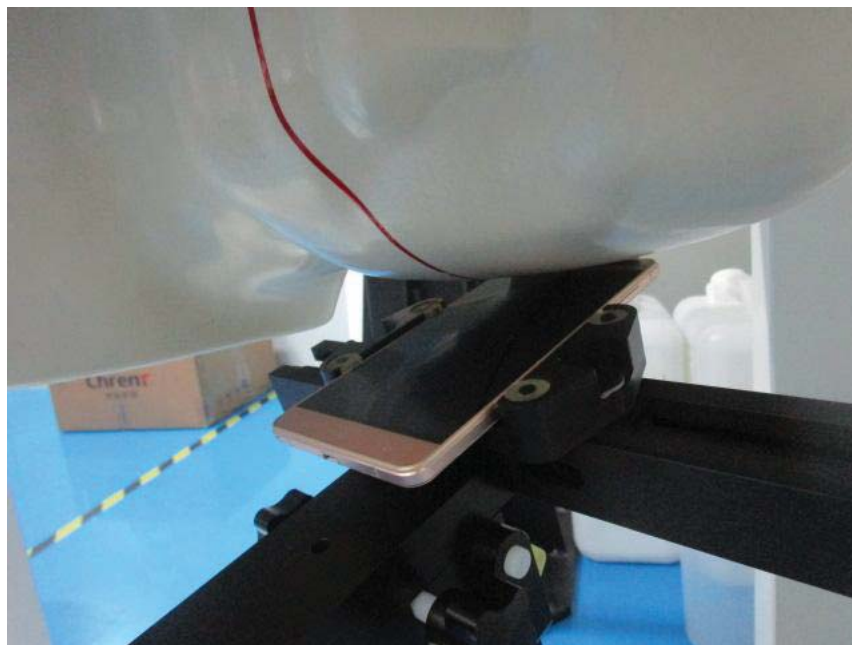

**Right Head Check**

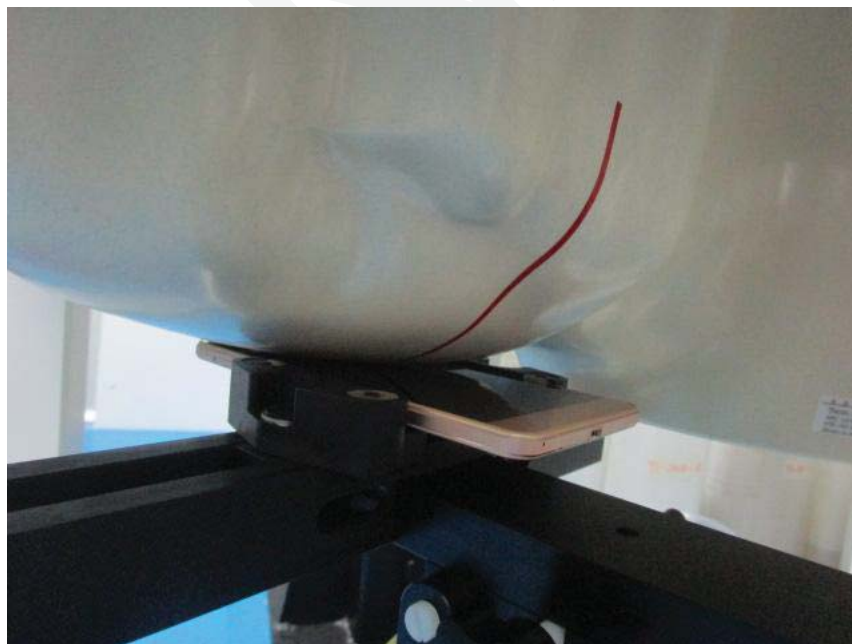

**Right Head Tilt**

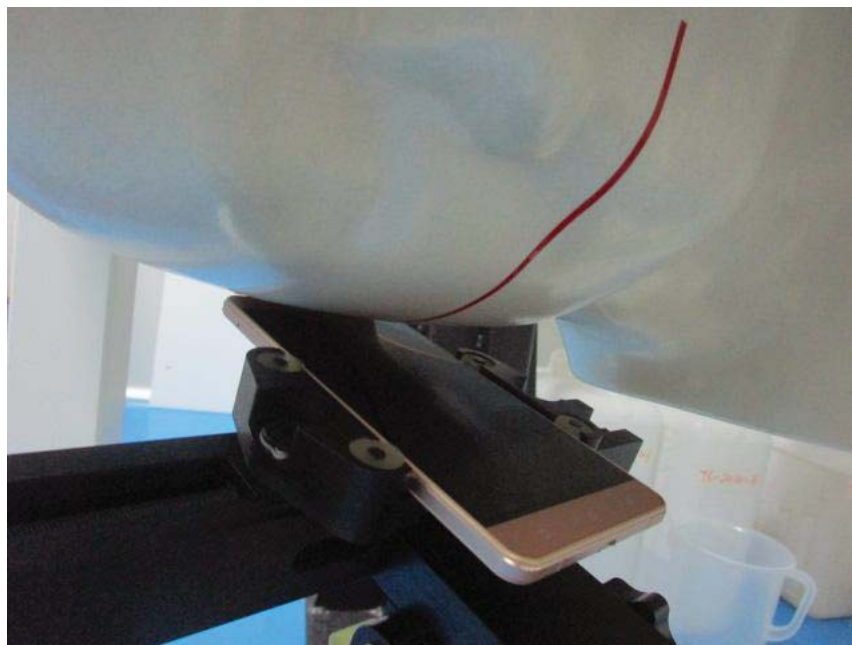

**Body -Worn-Back (10mm)**

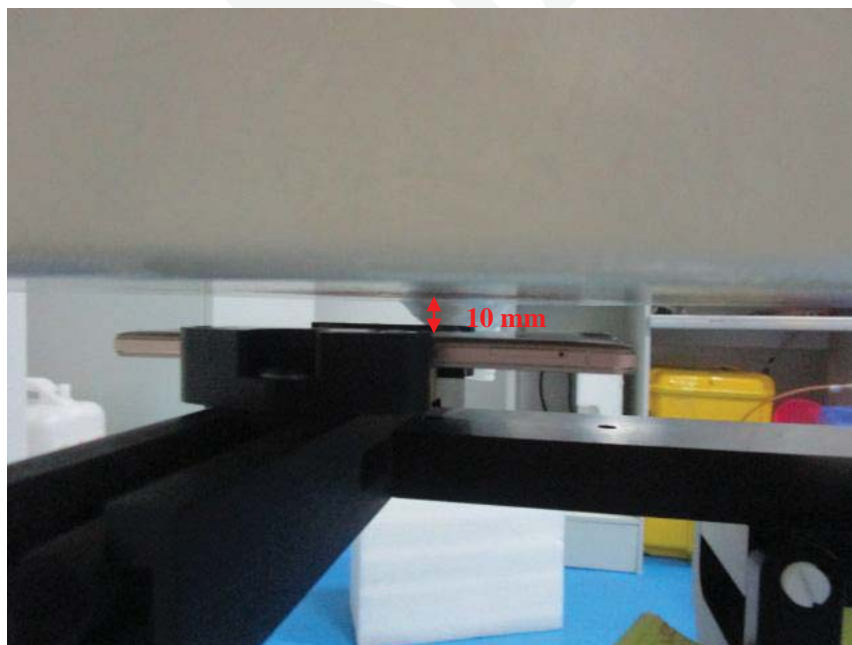

**Body -Headset-Back (10mm)**



**Body -Worn-Left (10mm)**



**Body -Worn-Right (10mm)**



**Body -Worn-Bottom(10mm)**





### APPENDIX E EUT PHOTOS

**EUT – Front View**

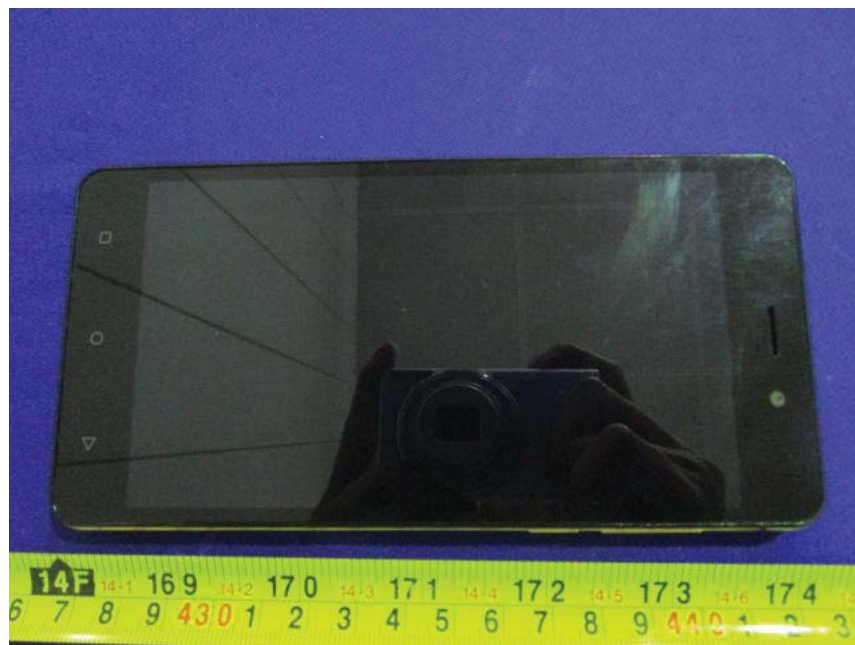

**EUT – Back View**



**EUT – Side View-1**



**EUT – Side View-2**



**EUT – Uncover View**



**\*\*\*\*\* END OF REPORT \*\*\*\*\***