



SAR EVALUATION REPORT

For

MAXWEST INTERNATIONAL LIMITED

No.1,Longgang Road,Buji,Longgang,ShenzhenCity,Guangdong Province, P.R. China

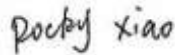
FCC ID:2AEN3GRAVITY5

Report Type: Original Report	Product Type: Mobile Phone
Test Engineer: Rocky Xiao	
Report Number: RDG150807007-20	
Report Date: 2015-08-14	
Reviewed By: Sula Huang RF Leader	
Test Laboratory: Bay Area Compliance Laboratories Corp. (Dongguan) No.69 Pulongcun, Puxinhu Industrial Zone, Tangxia, Dongguan, Guangdong, China Tel: +86-769-86858888 Fax: +86-769-86858891 www.baclcorp.com.cn	

Note: This test report is prepared for the customer shown above and for the device described herein. It may not be duplicated or used in part without prior written consent from Bay Area Compliance Laboratories Corp. (Dongguan). This report is valid only with a valid digital signature. The digital signature may be available only under the Adobe software above version 7.0.

Attestation of Test Results			
EUT Information	Company Name	MAXWEST INTERNATIONAL LIMITED	
	EUT Description	Gravity 5	
	FCC ID	2AEN3GRAVITY5	
	Model Number:	Gravity 5	
	Serial Number:	150807007	
	Test Date	2015-08-12,2015-08-13	
MODE		Max. SAR Level(s) Reported(W/Kg)	Limit(W/Kg)
GSM 850	1g Head SAR	0.087	1.6
	1g Body SAR	0.496	
PCS 1900	1g Head SAR	0.134	
	1g Body SAR	0.935	
WCDMA 850	1g Head SAR	0.07	
	1g Body SAR	0.305	
WCDMA 1900	1g Head SAR	0.242	
	1g Body SAR	0.997	
Simultaneous	1g Head SAR	0.641	
	1g Body SAR	1.196	
Hotspot	1g Body SAR	1.196	
Applicable Standards	ANSI / IEEE C95.1 : 2005 IEEE Standard for Safety Levels with Respect to Human Exposure to Radio Frequency Electromagnetic Fields,3 kHz to 300 GHz.		
	ANSI / IEEE C95.3 : 2002 IEEE Recommended Practice for Measurements and Computations of Radio Frequency Electromagnetic Fields With Respect to Human Exposure to Such Fields,100 kHz—300 GHz.		
	FCC 47 CFR part 2.1093 Radiofrequency radiation exposure evaluation: portable devices		
	IEEE1528:2013 IEEE Recommended Practice for Determining the Peak Spatial-Average Specific Absorption Rate (SAR) in the Human Head from Wireless Communications Devices: Measurement Techniques		
	IEC 62209-2:2010 Human exposure to radio frequency fields from hand-held and body-mounted wireless communication devices-Human models, instrumentation, and procedures-Part 2: Procedure to determine the specific absorption rate (SAR) for wireless communication devices used in close proximity to the human body (frequency range of 30 MHz to 6 GHz)		
	KDB procedures KDB 447498 D01 General RF Exposure Guidance v05r02. KDB 648474 D04 Handset SAR v01r02. KDB 865664 D01 SAR measurement 100 MHz to 6 GHz v01r04 KDB 865664 D02 RF Exposure Reporting v01r01 KDB 941225 D01 3G SAR Procedures v03 KDB 941225 D06 Hotspot Mode v02		
<p>Note: This wireless device has been shown to be capable of compliance for localized specific absorption rate (SAR) for General Population/Uncontrolled Exposure limits specified in ANSI/IEEE Standards and has been tested in accordance with the measurement procedures specified in IEEE 1528-2013 and RF exposure KDB procedures.</p> <p>The results and statements contained in this report pertain only to the device(s) evaluated.</p>			

TABLE OF CONTENTS

DOCUMENT REVISION HISTORY	5
EUT DESCRIPTION	6
TECHNICAL SPECIFICATION	6
REFERENCE, STANDARDS, AND GUIDELINES	7
SAR LIMITS	8
FACILITIES.....	9
DESCRIPTION OF TEST SYSTEM	10
EQUIPMENT LIST AND CALIBRATION	15
EQUIPMENTS LIST & CALIBRATION INFORMATION	15
SAR MEASUREMENT SYSTEM VERIFICATION	16
LIQUID VERIFICATION	16
SYSTEM ACCURACY VERIFICATION	19
SAR SYSTEM VALIDATION DATA	20
EUT TEST STRATEGY AND METHODOLOGY	24
TEST POSITIONS FOR DEVICE OPERATING NEXT TO A PERSON’S EAR.....	24
CHEEK/TOUCH POSITION	25
EAR/TILT POSITION	25
TEST POSITIONS FOR BODY-WORN AND OTHER CONFIGURATIONS.....	26
SAR EVALUATION PROCEDURE.....	26
TEST METHODOLOGY	27
CONDUCTED OUTPUT POWER MEASUREMENT	28
PROVISION APPLICABLE	28
TEST PROCEDURE	28
RADIO CONFIGURATION	28
MAXIMUM TARGET OUTPUT POWER	33
TEST RESULTS:	34
SAR MEASUREMENT RESULTS	39
SAR TEST DATA.....	39
SAR SIMULTANEOUS TRANSMISSION DESCRIPTION	44
SAR PLOTS (SUMMARY OF THE HIGHEST SAR VALUES).....	48
APPENDIX A MEASUREMENT UNCERTAINTY	56
APPENDIX B – PROBE CALIBRATION CERTIFICATES.....	58
APPENDIX C DIPOLE CALIBRATION CERTIFICATES	69
APPENDIX D EUT TEST POSITION PHOTOS	87
BODY-WORN BACK SETUP PHOTO	87
BODY-WORN LEFT SETUP PHOTO	88
BODY-WORN RIGHT SETUP PHOTO	88
BODY-WORN HEADSET SETUP PHOTO	89
BODY-WORN BOTTOM SETUP PHOTO	89
LEFT HEAD TOUCH SETUP PHOTO	90
LEFT HEAD TILT SETUP PHOTO	90
RIGHT HEAD TOUCH SETUP PHOTO	91
RIGHT HEAD TILT SETUP PHOTO	91
APPENDIX E EUT PHOTOS.....	92
EUT – FRONT VIEW.....	92

EUT –BACK VIEW	92
EUT – TOP SIDE VIEW.....	93
EUT – BOTTOM SIDE VIEW	93
EUT –LEFT SIDE VIEW.....	94
EUT – RIGHT SIDE VIEW.....	94
EUT – COVER OFF VIEW.....	95

F E M A L

DOCUMENT REVISION HISTORY

Revision Number	Report Number	Description of Revision	Date of Revision
0	RDG150807007-20	Original Report	2015-08-14

FINAL

EUT DESCRIPTION

This report has been prepared on behalf of MAXWEST INTERNATIONAL LIMITED and their product, Model: Gravity 5, FCC ID: 2AEN3GRAVITY5 or the EUT (Equipment under Test) as referred to in the rest of this report.

Technical Specification

Product Type	Gravity 5
Exposure Category:	Population / Uncontrolled
Antenna Type(s):	Internal Antenna
Body-Worn Accessories:	Portable
Face-Head Accessories:	None
Operation Mode :	GSM Voice, GPRS/EDGE Multi-slot Class 12, WCDMA R99 (Voice+Data),HSUPA,HSDPA,DC-HSDPA,HSPA+ WLAN Bluetooth
Frequency Band:	GSM 850 : 824-849 MHz(TX) ; 869-894 MHz(RX) PCS 1900: 1850-1910 MHz(TX) ; 1930-1990 MHz(RX) WCDMA850: 824-849 MHz(TX) ; 869-894 MHz(RX) WCDMA1900: 1850-1910 MHz(TX) ; 1930-1990 MHz(RX) WLAN: 2412MHz-2462MHz Bluetooth : 2402MHz-2480MHz
Conducted RF Power:	GSM 850 : 33.31 dBm PCS 1900:28.46 dBm WCDMA 850: 22.46 dBm WCDMA 1900: 23 dBm WLAN: 9.68 dBm Bluetooth:-4.25 dBm
Dimensions (L*W*H):	146 mm (L) × 73.5 mm (W) × 8.5 mm (H)
Power Source:	3.7 VDC Rechargeable Battery
Normal Operation:	Head and Body-worn

REFERENCE, STANDARDS, AND GUIDELINES

FCC:

The Report and Order requires routine SAR evaluation prior to equipment authorization of portable transmitter devices, including portable telephones. For consumer products, the applicable limit is 1.6 mW/g as recommended by the ANSI/IEEE standard C95.1-1992 [6] for an uncontrolled environment (Paragraph 65). According to the Supplement C of OET Bulletin 65 "Evaluating Compliance with FCC Guide-lines for Human Exposure to Radio frequency Electromagnetic Fields", released on Jun 29, 2001 by the FCC, the device should be evaluated at maximum output power (radiated from the antenna) under "worst-case" conditions for normal or intended use, incorporating normal antenna operating positions, device peak performance frequencies and positions for maximum RF energy coupling.

This report describes the methodology and results of experiments performed on wireless data terminal. The objective was to determine if there is RF radiation and if radiation is found, what is the extent of radiation with respect to safety limits. SAR (Specific Absorption Rate) is the measure of RF exposure determined by the amount of RF energy absorbed by human body (or its parts) – to determine how the RF energy couples to the body or head which is a primary health concern for body worn devices. The limit below which the exposure to RF is considered safe by regulatory bodies in North America is 1.6 mW/g average over 1 gram of tissue mass.

CE:

The order requires routine SAR evaluation prior to equipment authorization of portable transmitter devices, including portable telephones. For consumer products, the applicable limit is 2 mW/g as recommended by EN62209-1 for an uncontrolled environment. According to the Standard, the device should be evaluated at maximum output power (radiated from the antenna) under "worst-case" conditions for normal or intended use, incorporating normal antenna operating positions, device peak performance frequencies and positions for maximum RF energy coupling.

This report describes the methodology and results of experiments performed on wireless data terminal. The objective was to determine if there is RF radiation and if radiation is found, what is the extent of radiation with respect to safety limits. SAR (Specific Absorption Rate) is the measure of RF exposure determined by the amount of RF energy absorbed by human body (or its parts) – to determine how the RF energy couples to the body or head which is a primary health concern for body worn devices. The limit below which the exposure to RF is considered safe by regulatory bodies in Europe is 2 mW/g average over 10 gram of tissue mass.

The test configurations were laid out on a specially designed test fixture to ensure the reproducibility of measurements. Each configuration was scanned for SAR. Analysis of each scan was carried out to characterize the above effects in the device.

SAR Limits

FCC Limit (1g Tissue)

EXPOSURE LIMITS	SAR (W/kg)	
	(General Population / Uncontrolled Exposure Environment)	(Occupational / Controlled Exposure Environment)
Spatial Average (averaged over the whole body)	0.08	0.4
Spatial Peak (averaged over any 1 g of tissue)	1.60	8.0
Spatial Peak (hands/wrists/feet/ankles averaged over 10 g)	4.0	20.0

CE Limit (10g Tissue)

EXPOSURE LIMITS	SAR (W/kg)	
	(General Population / Uncontrolled Exposure Environment)	(Occupational / Controlled Exposure Environment)
Spatial Average (averaged over the whole body)	0.08	0.4
Spatial Peak (averaged over any 10 g of tissue)	2.0	10
Spatial Peak (hands/wrists/feet/ankles averaged over 10 g)	4.0	20.0

Population/Uncontrolled Environments are defined as locations where there is the exposure of individual who have no knowledge or control of their exposure.

Occupational/Controlled Environments are defined as locations where there is exposure that may be incurred by people who are aware of the potential for exposure (i.e. as a result of employment or occupation).

General Population/Uncontrolled environments Spatial Peak limit 1.6W/kg (FCC) & 2 W/kg (CE) applied to the EUT.

FACILITIES

The Test site used by Bay Area Compliance Laboratories Corp. (Dongguan) to collect test data is located on the No.69 Pulongcun, Puxinhu Industrial Zone, Tangxia, Dongguan, Guangdong, China

F E M A L

DESCRIPTION OF TEST SYSTEM

These measurements were performed with the automated near-field scanning system DASY5 from Schmid & Partner Engineering AG (SPEAG) which is the Fifth generation of the system shown in the figure hereinafter:



DASY5 System Description

The DASY5 system for performing compliance tests consists of the following items:

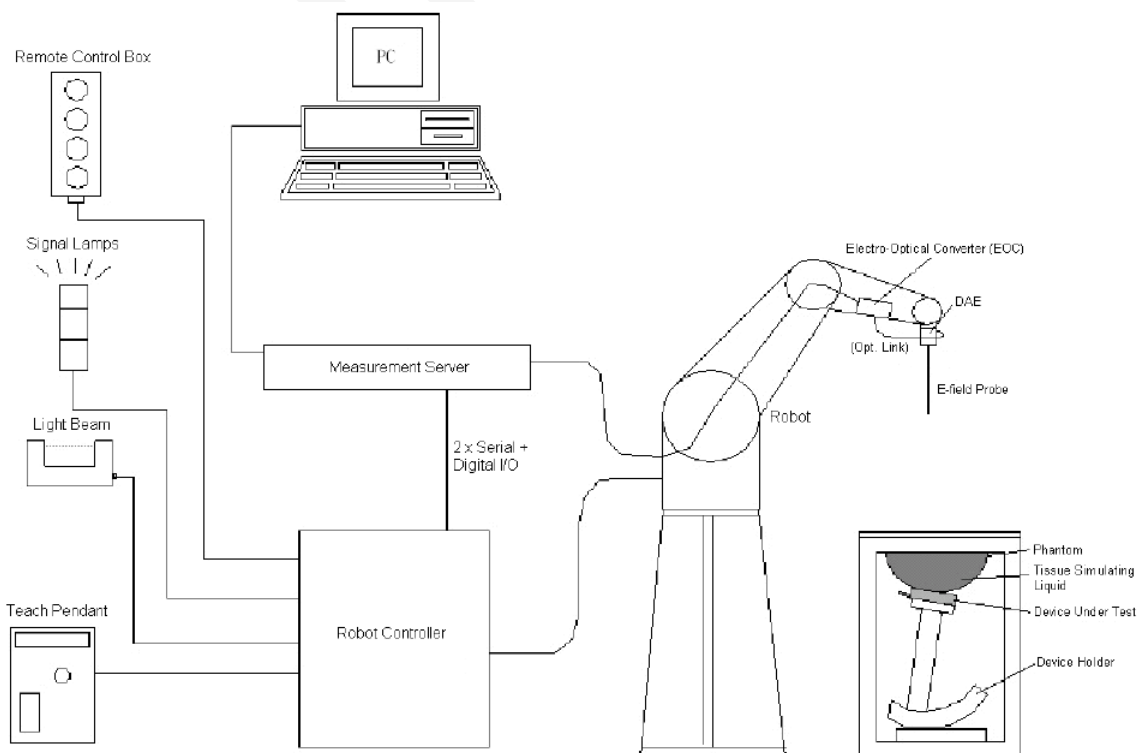

- A standard high precision 6-axis robot (Staubli TX=RX family) with controller, teach pendant and software. An arm extension for accommodating the data acquisition electronics (DAE).
- An isotropic field probe optimized and calibrated for the targeted measurement.
- A data acquisition electronics (DAE) which performs the signal amplification, signal multiplexing, AD-conversion, offset measurements, mechanical surface detection, collision detection, etc. The unit is battery powered with standard or rechargeable batteries. The signal is optically transmitted to the EOC.
- The Electro-optical converter (EOC) performs the conversion from optical to electrical signals for the digital communication to the DAE. To use optical surface detection, a special version of the EOC is required. The EOC signal is transmitted to the measurement server.
- The function of the measurement server is to perform the time critical tasks such as signal filtering, control of the robot operation and fast movement interrupts.
- The Light Beam used is for probe alignment. This improves the (absolute) accuracy of the probe positioning.
- A computer running Win7 professional operating system and the DASY52 software.
- Remote control and teach pendant as well as additional circuitry for robot safety such as warning lamps, etc.
- The phantom, the device holder and other accessories according to the targeted measurement.

DASY5 Measurement Server

The DASY5 measurement server is based on a PC/104 CPU board with a 400MHz intel ULV Celeron, 128MB chip-disk and 128MB RAM. The necessary circuits for communication with the DAE4 (or DAE3) electronics box, as well as the 16 bit AD converter system for optical detection and digital I/O interface are contained on the DASY5 I/O board, which is directly connected to the PC/104 bus of the CPU board.



The measurement server performs all real-time data evaluation of field measurements and surface detection, controls robot movements and handles safety operation. The PC operating system cannot interfere with these time critical processes. All connections are supervised by a watchdog, and disconnection of any of the cables to the measurement server will automatically disarm the robot and disable all program-controlled robot movements. Furthermore, the measurement server is equipped with an expansion port which is reserved for future applications. Please note that this expansion port does not have a standardized point out, and therefore only devices provided by SPEAG can be connected. Devices from any other supplier could seriously damage the measurement server.

Data Acquisition Electronics

The data acquisition electronics (DAE4) consist of a highly sensitive electrometer-grade preamplifier with auto-zeroing, a channel and gain-switching multiplexer, a fast 16 bit AD-converter and a command decoder with a control logic unit. Transmission to the measurement server is accomplished through an optical downlink for data and status information, as well as an optical uplink for commands and the clock.

The mechanical probe mounting device includes two different sensor systems for frontal and sideways probe contacts. They are used for mechanical surface detection and probe collision detection.

The input impedance of both the DAE4 as well as of the DAE3 box is 200MOhm; the inputs are symmetrical and floating. Common mode rejection is above 80 dB.

EX3DV4 E-Field Probes

Frequency	10 MHz to > 6 GHz Linearity: ±0.2 dB (30 MHz to 6 GHz)
Directivity	±0.3 dB in TSL (rotation around probe axis) ±0.5 dB in TSL (rotation normal to probe axis)
Dynamic Range	10 µW/g to > 100 mW/g Linearity: ±0.2 dB (noise: typically < 1 µW/g)
Dimensions	Overall length: 337 mm (Tip: 20 mm) Tip diameter: 2.5 mm (Body: 12 mm) Typical distance from probe tip to dipole centers: 1 mm
Application	High precision dosimetric measurements in any exposure scenario (e.g., very strong gradient fields); the only probe that enables compliance testing for frequencies up to 6 GHz with precision of better 30%.
Compatibility	DASY3, DASY4, DASY52 SAR and higher, EASY4/MRI

SAM Twin Phantom

The SAM twin phantom is a fiberglass shell phantom with 2mm shell thickness (except the ear region, where shell thickness increases to 6 mm). The phantom has three measurement areas:

- _ Left hand
- _ Right hand
- _ Flat phantom

The phantom table for the DASY systems based on the TX90XL and RX160L robots have the size of 100 x 50 x 85 cm (L xWx H). The phantom table for the compact DASY systems based on the RX60L robot have the size of 100 x 75 x 91 cm (L xWx H); these tables are reinforced for mounting of the robot onto the table.

For easy dislocation these tables have fork lift cut outs at the bottom.

The bottom plate contains three pairs of bolts for locking the device holder. The device holder positions are adjusted to the standard measurement positions in the three sections. Only one device holder is necessary if two phantoms are used (e.g., for different liquids)



A white cover is provided to cover the phantom during the periods to prevent water evaporation and changes in the liquid parameters. Free space scans of devices on top of this phantom cover are possible. Three reference marks are provided on the phantom counter. These reference marks are used to teach the absolute phantom position relative to the robot.

Device Holder for SAM Twin Phantom

The SAR in the phantom is approximately inversely proportional to the square of the distance between the source and the liquid surface. For a source in 5mm distance, a positioning uncertainty of ± 0.5 mm would produce a SAR uncertainty of $\pm 20\%$. An accurate device positioning is therefore crucial for accurate and repeatable measurements. The positions, in which the devices must be measured, are defined by the standards.

The DASY device holder is designed to cope with different positions given in the standard. It has two scales for the device rotation (with respect to the body axis) and the device inclination (with respect to the line between the ear reference points). The rotation centers for both scales are the ear reference point ERP). Thus the device needs no repositioning when changing the angles.



The DASY device holder has been made out of low-loss POM material having the following dielectric parameters: relative permittivity $\epsilon' = 3$ and loss tangent $\epsilon'' = 0.02$. The amount of dielectric material has been reduced in the closest vicinity of the device, since measurements have suggested that the influence of the clamp on the test results could thus be lowered.

Robots

The DASY5 system uses the high precision industrial robots TX90XL from Staubli SA (France). The TX robot family is the successor of the well known RX robot family and offers the same features important for our application:

- High precision (repeatability 0.02mm)
- High reliability (industrial design)
- Low maintenance costs (virtually maintenance free due to direct drive gears; no belt drives)
- Jerk-free straight movements (brushless synchron motors; no stepper motors)
- Low ELF interference (motor control fields shielded via the closed metallic construction shields)

The above mentioned robots are controlled by the Staubli CS8c robot controllers. All information regarding the use and maintenance of the robot arm and the robot controller is contained on the CDs delivered along with the robot. Paper manuals are available upon request direct from Staubli.

Area Scans

Area scans are defined prior to the measurement process being executed with a user defined variable spacing between each measurement point (integral) allowing low uncertainty measurements to be conducted. Scans defined for FCC applications utilize a 10mm² step integral, with 1mm interpolation used to locate the peak SAR area used for zoom scan assessments.

Where the system identifies multiple SAR peaks (which are within 25% of peak value) the system will provide the user with the option of assessing each peak location individually for zoom scan averaging.

Zoom Scan (Cube Scan Averaging)

The averaging zoom scan volume utilized in the DASY5 software is in the shape of a cube and the side dimension of a 1 g or 10 g mass is dependent on the density of the liquid representing the simulated tissue. A density of 1000 kg/m³ is used to represent the head and body tissue density and not the phantom liquid density, in order to be consistent with the definition of the liquid dielectric properties, i.e. the side length of the 1 g cube is 10mm, with the side length of the 10 g cube 21,5mm.

When the cube intersects with the surface of the phantom, it is oriented so that 3 vertices touch the surface of the shell or the center of a face is tangent to the surface. The face of the cube closest to the surface is modified in order to conform to the tangent surface.

The zoom scan integer steps can be user defined so as to reduce uncertainty, but normal practice for typical test applications (including FCC) utilize a physical step of 5x5x8 (8mmx8mmx5mm) providing a volume of 32mm³ in the X & Y axis, and 35mm in the Z axis.

EQUIPMENT LIST AND CALIBRATION

Equipments List & Calibration Information

Equipment	Model	S/N	Calibration Date	Calibration Due Date
Robot	RX90	D03636	N/A	N/A
DASY5 Test Software	DASY52.8	N/A	N/A	N/A
DASY5 Measurement Server	DASY5 4.5.12	1470	N/A	N/A
Data Acquisition Electronics	DAE4	1459	2015-01-26	2016-01-26
E-Field Probe	EX3DV4	7329	2015-02-05	2016-02-05
Dipole, 835MHz	ALS-D-835-S-2	180-00558	2014-10-08	2017-10-08
Dipole, 1900MHz	ALS-D-1900-S-2	210-00710	2013-10-09	2016-10-09
R&S, universal Radio Communication Tester	CMU200	105047	2014-11-20	2015-11-20
Mounting Device	MD4HHTV5	SD 000 H01 KA	N/A	N/A
Twin SAM	Twin SAM V5.0	1874	N/A	N/A
Simulated Tissue 835 MHz Head	TS-835-H	201504	Each Time	/
Simulated Tissue 835 MHz Body	TS-835-B	201505	Each Time	/
Simulated Tissue 1900 MHz Head	TS-1900-H	201506	Each Time	/
Simulated Tissue 1900 MHz Body	TS-1900-B	201507	Each Time	/
Network Analyzer	8752C	3140A02356	2015-06-03	2016-06-03
Dielectric probe kit	85070B	US33020324	2015-06-03	2016-06-03
Signal Generator	E4422B	MY41000355	2014-10-27	2015-10-27
Power Meter	EPM-441A	GB37481494	2014-11-03	2015-11-03
Power Meter Sensor	8481A	T-03-EM-127	2014-11-03	2015-11-03
Power Amplifier	5205PE	1015	N/A	N/A
Directional Coupler	488Z	N/A	N/A	N/A
attenuator	20dB, 100W	N/A	N/A	N/A

SAR MEASUREMENT SYSTEM VERIFICATION

Liquid Verification

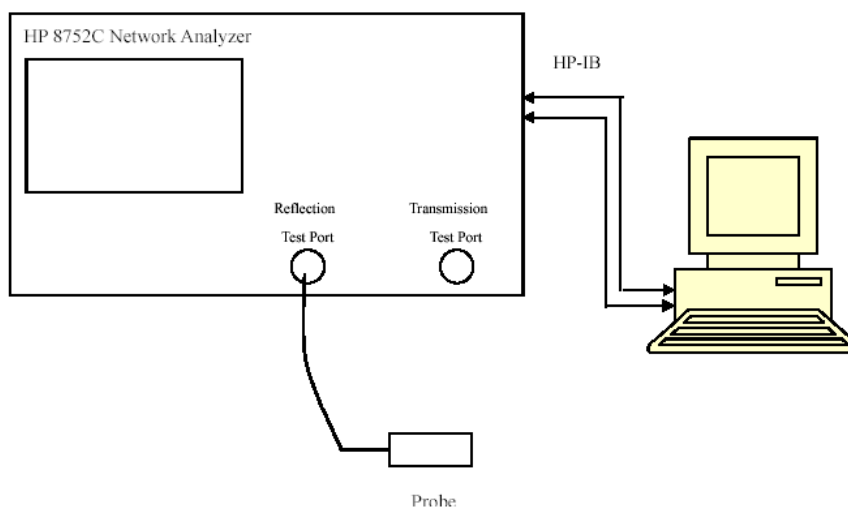

Liquid Verification Setup Block Diagram

Liquid Verification Results

Frequency	Liquid Type	Liquid Parameter		Target Value		Delta(%)		Tolerance (%)
		ϵ_r	σ (S/m)	ϵ_r	σ (S/m)	$\Delta\epsilon_r$	$\Delta\sigma$ (S/m)	
824.2	Head	42.92	0.88	41.5	0.9	3.42	-2.22	± 5
	Body	55.15	0.96	55.2	0.97	-0.09	-1.03	± 5
826.4	Head	42.88	0.88	41.5	0.9	3.33	-2.22	± 5
	Body	55.15	0.97	55.2	0.97	-0.09	0	± 5
836.6	Head	42.85	0.89	41.5	0.9	3.25	-1.11	± 5
	Body	55.09	0.98	55.2	0.97	-0.2	1.03	± 5
846.6	Head	42.81	0.9	41.5	0.9	3.16	0	± 5
	Body	55.01	0.98	55.2	0.97	-0.34	1.03	± 5
848.8	Head	42.7	0.9	41.5	0.9	2.89	0	± 5
	Body	55.02	0.99	55.2	0.97	-0.33	2.06	± 5

*Liquid Verification was performed on 2015-08-13.

Frequency	Liquid Type	Liquid Parameter		Target Value		Delta(%)		Tolerance (%)
		ϵ_r	σ (S/m)	ϵ_r	σ (S/m)	$\Delta\epsilon_r$	$\Delta\sigma$ (S/m)	
1850.2	Head	39.85	1.36	40	1.4	-0.37	-2.86	± 5
	Body	55.3	1.48	53.3	1.52	3.75	-2.63	± 5
1852.4	Head	39.86	1.36	40	1.4	-0.35	-2.86	± 5
	Body	55.22	1.48	53.3	1.52	3.6	-2.63	± 5
1880	Head	39.72	1.39	40	1.4	-0.7	-0.71	± 5
	Body	53.72	1.54	53.3	1.52	0.79	1.32	± 5
1907.6	Head	39.56	1.41	40	1.4	-1.1	0.71	± 5
	Body	53.59	1.49	53.3	1.52	0.54	-1.97	± 5
1909.8	Head	39.6	1.42	40	1.4	-1	1.43	± 5
	Body	53.4	1.49	53.3	1.52	0.19	-1.97	± 5

*Liquid Verification was performed on 2015-08-12.

Please refer to the following tables.

835 MHz Head			835 MHz Body		
Frequency (MHz)	e'	e''	Frequency (MHz)	e'	e''
824	42.8829	19.1684	824	55.1528	21.0769
824.5	42.9815	19.1342	824.5	55.1506	20.9329
825	42.9485	19.1565	825	55.1239	21.0274
825.5	42.9349	19.1821	825.5	55.218	20.9817
826	42.9136	19.1347	826	55.1134	21.0319
826.5	42.8675	19.1408	826.5	55.1623	21.0302
827	42.9195	19.1543	827	55.0024	20.985
827.5	42.9119	19.1636	827.5	55.1669	20.9711
828	42.9704	19.237	828	55.1079	20.9912
828.5	42.9399	19.2008	828.5	55.2071	20.9984
829	42.9399	19.2576	829	55.1097	20.9548
829.5	42.9327	19.1728	829.5	55.0964	20.8987
830	42.9938	19.205	830	55.1167	20.9672
830.5	42.9592	19.2112	830.5	55.1299	20.9555
831	42.9599	19.2124	831	55.0854	20.9397
831.5	42.8662	19.1814	831.5	55.1673	20.9552
832	42.9609	19.1764	832	55.2199	20.9419
832.5	42.943	19.239	832.5	55.0927	20.9303
833	42.9583	19.2005	833	55.1293	20.9037
833.5	42.9078	19.2144	833.5	55.1455	20.9742
834	42.8887	19.2092	834	55.1766	21.0277
834.5	42.8864	19.1831	834.5	55.0971	20.9645
835	42.954	19.2144	835	55.0874	20.9524
835.5	42.9257	19.1659	835.5	55.0863	21.0035
836	42.9039	19.1446	836	55.0962	21.0226
836.5	42.8494	19.1634	836.5	55.0942	20.9887
837	42.8376	19.2144	837	55.071	20.9809
837.5	42.8747	19.2098	837.5	55.0027	20.9043
838	42.8581	19.2284	838	55.0932	21.0021
838.5	42.919	19.2113	838.5	55.1472	21.0287
839	42.8997	19.205	839	55.0891	20.9738
839.5	42.9274	19.1349	839.5	55.0816	21.0439
840	42.8996	19.1401	840	55.0486	21.0214
840.5	42.9015	19.0781	840.5	55.1721	20.9873
841	42.9262	19.1766	841	55.0757	20.985
841.5	42.8784	19.1289	841.5	55.0377	20.9614
842	42.8886	19.0833	842	55.0818	20.9517
842.5	42.8002	19.1573	842.5	55.0075	20.9627
843	42.8259	19.0868	843	55.0346	20.9547
843.5	42.7996	19.1051	843.5	54.9923	20.9318
844	42.7862	19.0948	844	55.0775	20.9002
844.5	42.8753	18.9949	844.5	55.0495	21.0065
845	42.7565	19.0787	845	55.1038	20.9821
845.5	42.8106	19.0823	845.5	55.0367	20.9159
846	42.8787	19.0002	846	55.0177	20.9641
846.5	42.829	19.0119	846.5	55.0046	20.8997
847	42.7306	19.1053	847	55.0354	20.9606
847.5	42.763	18.9754	847.5	55.0452	21.0068
848	42.7864	19.0206	848	55.0242	21.0004
848.5	42.7164	18.9926	848.5	55.0084	20.8913
849	42.6888	18.9802	849	55.0241	20.9051

1900 MHz Head			1900 MHz Body		
Frequency (MHz)	e'	e''	Frequency (MHz)	e'	e''
1850	39.8495	13.2143	1850	55.28	14.354
1851	39.8735	13.2018	1851	55.3579	14.3462
1852	39.8612	13.1763	1852	55.2448	14.3374
1853	39.8558	13.1637	1853	55.1935	14.2993
1854	39.8828	13.1568	1854	55.0579	14.1523
1855	39.8886	13.2141	1855	55.0612	14.2491
1856	39.8389	13.1957	1856	54.8963	14.2794
1857	39.886	13.1783	1857	54.7385	14.1959
1858	39.8559	13.2067	1858	54.6465	14.1224
1859	39.8027	13.1859	1859	54.572	14.0449
1860	39.8233	13.2092	1860	54.4377	14.1852
1861	39.8394	13.1989	1861	54.4811	14.0768
1862	39.8907	13.1995	1862	54.3462	14.114
1863	39.8404	13.1501	1863	54.2072	14.1475
1864	39.8343	13.1968	1864	54.1481	14.1399
1865	39.8429	13.2357	1865	54.073	14.1786
1866	39.8099	13.2036	1866	53.9953	14.145
1867	39.8065	13.1934	1867	53.8828	14.1577
1868	39.8039	13.1995	1868	53.8326	14.2179
1869	39.8581	13.2966	1869	53.7458	14.1978
1870	39.8653	13.2214	1870	53.6793	14.2981
1871	39.8149	13.209	1871	53.6392	14.2918
1872	39.8079	13.2088	1872	53.6958	14.3517
1873	39.7878	13.1658	1873	53.6772	14.4574
1874	39.7377	13.2374	1874	53.6142	14.4444
1875	39.758	13.2336	1875	53.595	14.4615
1876	39.7427	13.2322	1876	53.6372	14.5755
1877	39.7985	13.2535	1877	53.6608	14.6388
1878	39.7743	13.2191	1878	53.6241	14.6816
1879	39.722	13.2242	1879	53.6931	14.6409
1880	39.7229	13.2596	1880	53.7181	14.7431
1881	39.7332	13.242	1881	53.7497	14.7439
1882	39.7273	13.2641	1882	53.7668	14.7938
1883	39.7413	13.2872	1883	53.8119	14.8167
1884	39.7743	13.2544	1884	53.9131	14.7875
1885	39.7267	13.2837	1885	53.9599	14.8576
1886	39.67	13.2994	1886	54.1074	14.7803
1887	39.6741	13.2898	1887	54.1896	14.7986
1888	39.6953	13.2474	1888	54.2573	14.8135
1889	39.701	13.3138	1889	54.2355	14.7104
1890	39.6597	13.339	1890	54.2693	14.745
1891	39.7019	13.2932	1891	54.3528	14.7266
1892	39.6951	13.3118	1892	54.4069	14.7115
1893	39.6616	13.2961	1893	54.375	14.6794
1894	39.656	13.3043	1894	54.3506	14.6505
1895	39.6352	13.3059	1895	54.3197	14.5971
1896	39.6446	13.2835	1896	54.4363	14.5249
1897	39.6333	13.3078	1897	54.3881	14.488
1898	39.6385	13.2915	1898	54.4374	14.4123
1899	39.6426	13.282	1899	54.2601	14.3868
1900	39.6516	13.3431	1900	54.1952	14.3568

1900 MHz Head			1900 MHz Body		
Frequency (MHz)	e'	e''	Frequency (MHz)	e'	e''
1901	39.6558	13.2956	1901	54.1196	14.2636
1902	39.6289	13.3287	1902	54.085	14.2537
1903	39.6107	13.2758	1903	53.9868	14.1979
1904	39.6532	13.3615	1904	53.8579	14.1465
1905	39.6452	13.3473	1905	53.7738	14.1187
1906	39.6133	13.3386	1906	53.732	14.0992
1907	39.568	13.328	1907	53.6265	14.1426
1908	39.5607	13.3197	1908	53.5588	14.0579
1909	39.5641	13.3486	1909	53.4687	14.0347
1910	39.6148	13.3276	1910	53.3799	14.0389

System Accuracy Verification

Prior to the assessment, the system validation kit was used to test whether the system was operating within its specifications of $\pm 10\%$. The validation results are tabulated below. And also the corresponding SAR plot is attached as well in the SAR plots files.

System Verification Setup Block Diagram

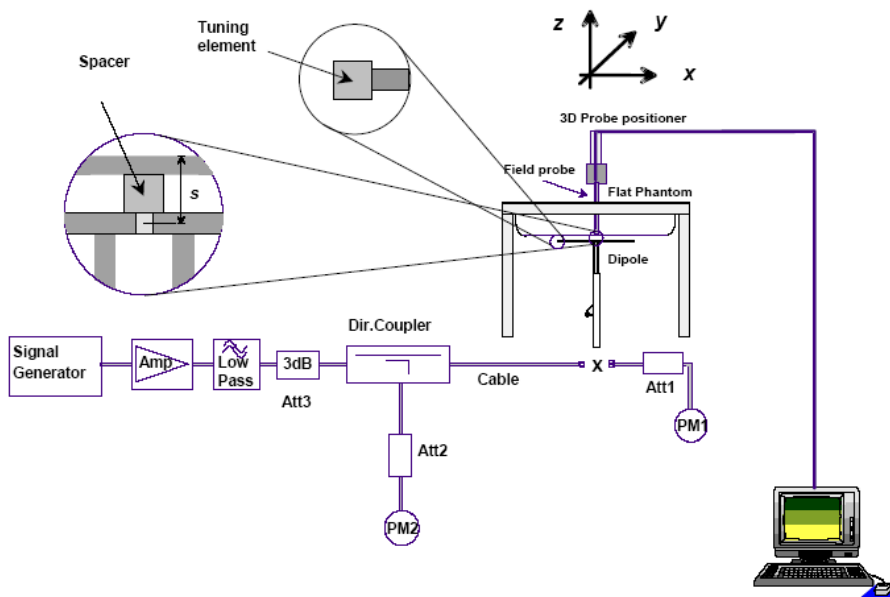

System Accuracy Check Results

Date	Frequency Band	Liquid Type	Measured SAR (W/Kg)	Target Value (W/Kg)	Delta (%)	Tolerance (%)
2015/8/13	835	Head	1g 10.3	9.773	5.39	± 10
		Body	1g 9.9	9.736	1.68	± 10
2015/8/12	1900	Head	1g 38.4	39.481	-2.74	± 10
		Body	1g 39	39.715	-1.80	± 10

*All SAR values are normalized to 1 Watt forward power.

SAR SYSTEM VALIDATION DATA

Test Laboratory: Bay Area Compliance Labs Corp.(Dongguan)

System Performance 835MHz Head

DUT: ALS-D-835-S-2; Type: 835 MHz; Serial: 180-00558

Communication System: CW; Frequency: 835 MHz; Duty Cycle: 1:1

Medium parameters used: $f = 835 \text{ MHz}$; $\sigma = 0.893 \text{ S/m}$; $\epsilon_r = 42.954$; $\rho = 1000 \text{ kg/m}^3$

Phantom section: Flat Section

DASY5 Configuration:

- Probe: EX3DV4 - SN7329; ConvF(9.52, 9.52, 9.52); Calibrated: 2015/2/5;
- Sensor-Surface: 4mm (Mechanical Surface Detection)
- Electronics: DAE4 Sn1459; Calibrated: 2015/1/26
- Phantom: SAM (30deg probe tilt) with CRP v5.0_20150321; Type: QD000P40CD; Serial: TP:1874
- Measurement SW: DASY52, Version 52.8 (8);

System Performance 835MHz Head /Area Scan (71x131x1): Interpolated grid: $dx=1.500 \text{ mm}$, $dy=1.500 \text{ mm}$
 Maximum value of SAR (interpolated) = 11.1 W/kg

System Performance 835MHz Head /Zoom Scan (7x7x7)/Cube 0: Measurement grid: $dx=5\text{mm}$, $dy=5\text{mm}$, $dz=5\text{mm}$

Reference Value = 111.3 V/m; Power Drift = 0.03 dB

Peak SAR (extrapolated) = 16.2 W/kg

SAR(1 g) = 10.3 W/kg; SAR(10 g) = 6.37 W/kg

Maximum value of SAR (measured) = 11.3 W/kg

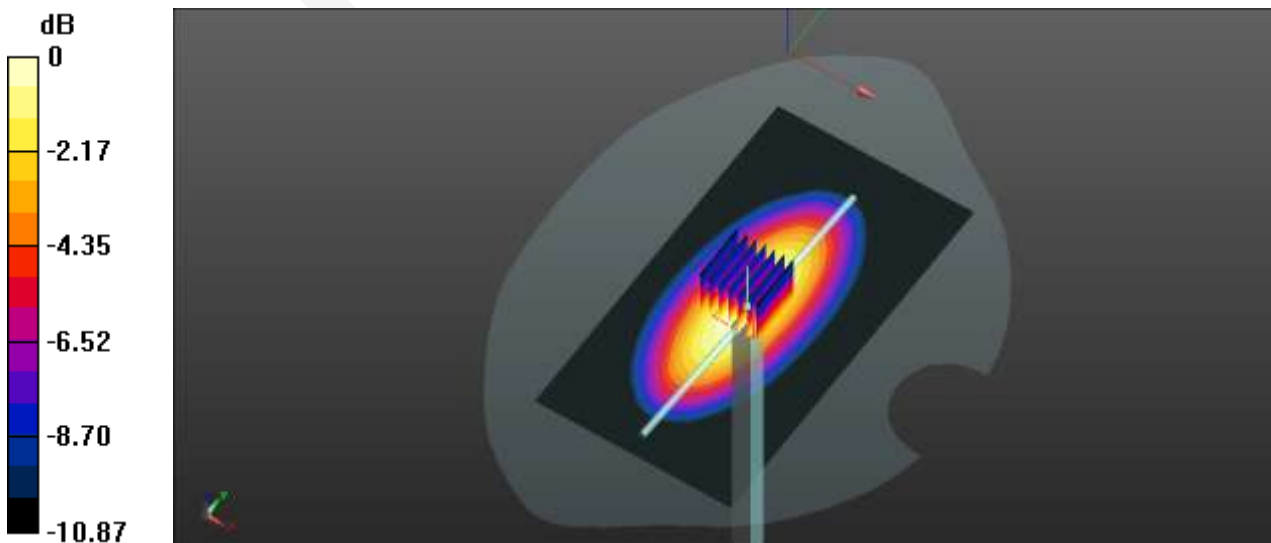

0 dB = 11.3 W/kg = 10.53 dBW/kg

Test Laboratory: Bay Area Compliance Labs Corp.(Dongguan)

System Performance 835MHz Body

DUT: ALS-D-835-S-2; Type: 835 MHz; Serial: 180-00558

Communication System: CW; Frequency: 835 MHz; Duty Cycle: 1:1

Medium parameters used: $f = 835 \text{ MHz}$; $\sigma = 0.973 \text{ S/m}$; $\epsilon_r = 55.087$; $\rho = 1000 \text{ kg/m}^3$

Phantom section: Flat Section

DASY5 Configuration:

- Probe: EX3DV4 - SN7329; ConvF(9.17, 9.17, 9.17); Calibrated: 2015/2/5;
- Sensor-Surface: 4mm (Mechanical Surface Detection)
- Electronics: DAE4 Sn1459; Calibrated: 2015/1/26
- Phantom: SAM (30deg probe tilt) with CRP v5.0_20150321; Type: QD000P40CD; Serial: TP:1874
- Measurement SW: DASY52, Version 52.8 (8);

System Performance 835MHz Body /Area Scan (71x131x1): Interpolated grid: $dx=1.500 \text{ mm}$, $dy=1.500 \text{ mm}$

Maximum value of SAR (interpolated) = 9.60 W/kg

System Performance 835MHz Body /Zoom Scan (7x7x7)/Cube 0: Measurement grid: $dx=5\text{mm}$, $dy=5\text{mm}$, $dz=5\text{mm}$

Reference Value = 97.67 V/m; Power Drift = 0.01 dB

Peak SAR (extrapolated) = 13.3 W/kg

SAR(1 g) = 9.9 W/kg; SAR(10 g) = 6.14 W/kg

Maximum value of SAR (measured) = 10.59 W/kg

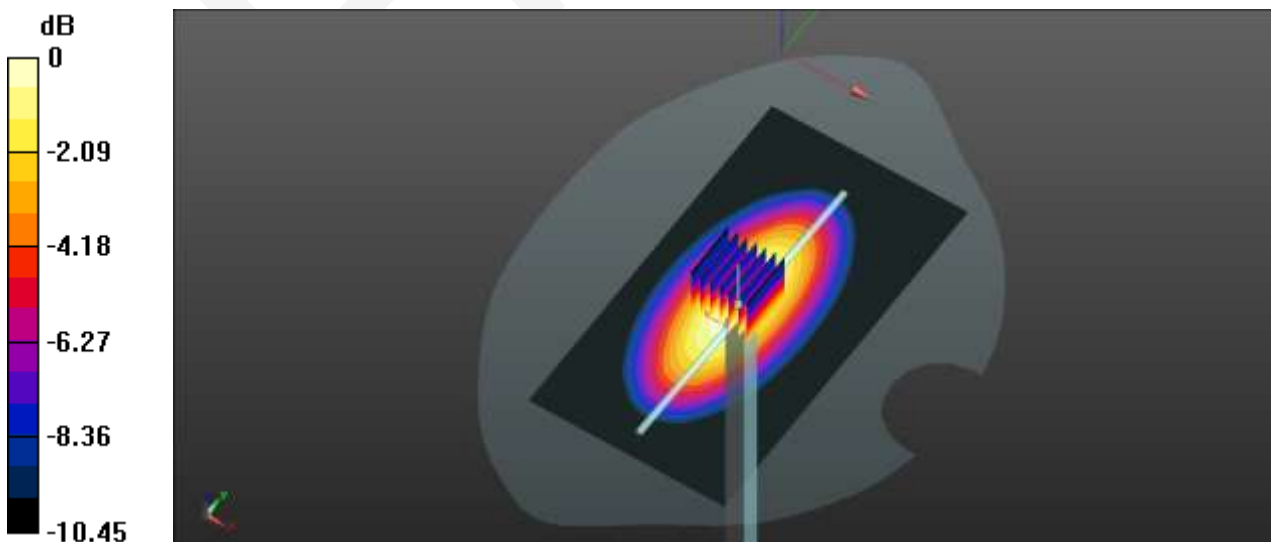

0 dB = 10.59 W/kg = 10.25 dBW/kg

Test Laboratory: Bay Area Compliance Labs Corp. (Dongguan)

System Performance 1900MHz Head

DUT: ALS-D-1900-S-2; Type: 1900 MHz; Serial: 210-00710

Communication System: CW; Frequency: 1900 MHz; Duty Cycle: 1:1

Medium parameters used: $f = 1900 \text{ MHz}$; $\sigma = 1.41 \text{ S/m}$; $\epsilon_r = 39.652$; $\rho = 1000 \text{ kg/m}^3$

Phantom section: Flat Section

DASY5 Configuration:

- Probe: EX3DV4 - SN7329; ConvF(7.88, 7.88, 7.88); Calibrated: 2015/2/5;
- Sensor-Surface: 4mm (Mechanical Surface Detection)
- Electronics: DAE4 Sn1459; Calibrated: 2015/1/26
- Phantom: SAM (30deg probe tilt) with CRP v5.0_20150321; Type: QD000P40CD; Serial: TP:1874
- Measurement SW: DASY52, Version 52.8 (8);

System Performance 1900MHz Head /Area Scan (61x81x1): Interpolated grid: $dx=1.500 \text{ mm}$, $dy=1.500 \text{ mm}$

Maximum value of SAR (interpolated) = 44.8 W/kg

System Performance 1900MHz Head /Zoom Scan (7x7x7)/Cube 0: Measurement grid: $dx=5\text{mm}$, $dy=5\text{mm}$, $dz=5\text{mm}$

Reference Value = 168.3 V/m; Power Drift = -0.06 dB

Peak SAR (extrapolated) = 71.2 W/kg

SAR(1 g) = 38.4 W/kg; SAR(10 g) = 19.4 W/kg

Maximum value of SAR (measured) = 42.5 W/kg

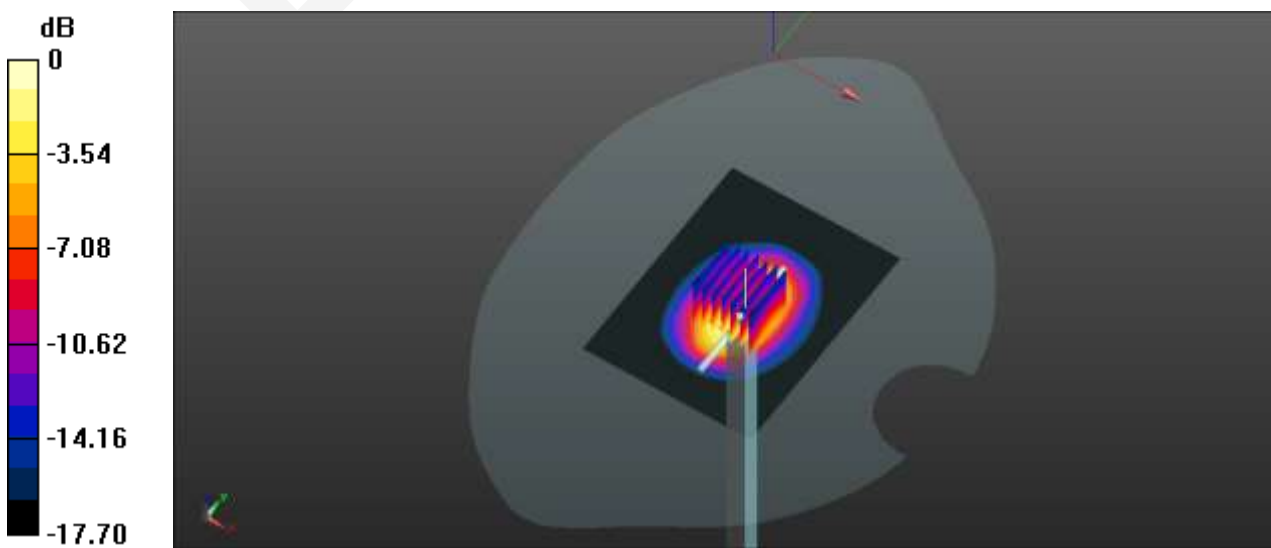

0 dB = 42.5 W/kg = 16.28 dBW/kg

Test Laboratory: Bay Area Compliance Labs Corp. (Dongguan)

System Performance 1900MHz Body

DUT: ALS-D-1900-S-2; Type: 1900 MHz; Serial: 210-00710

Communication System: CW; Frequency: 1900 MHz; Duty Cycle: 1:1

Medium parameters used: $f = 1900 \text{ MHz}$; $\sigma = 1.518 \text{ S/m}$; $\epsilon_r = 54.195$; $\rho = 1000 \text{ kg/m}^3$

Phantom section: Flat Section

DASY5 Configuration:

- Probe: EX3DV4 - SN7329; ConvF(7.56, 7.56, 7.56); Calibrated: 2015/2/5;
- Sensor-Surface: 4mm (Mechanical Surface Detection)
- Electronics: DAE4 Sn1459; Calibrated: 2015/1/26
- Phantom: SAM (30deg probe tilt) with CRP v5.0_20150321; Type: QD000P40CD; Serial: TP:1874
- Measurement SW: DASY52, Version 52.8 (8);

System Performance 1900MHz Body /Area Scan (61x81x1): Interpolated grid: $dx=1.500 \text{ mm}$, $dy=1.500 \text{ mm}$

Maximum value of SAR (interpolated) = 47.3 W/kg

System Performance 1900MHz Body /Zoom Scan (7x7x7)/Cube 0: Measurement grid: $dx=5\text{mm}$, $dy=5\text{mm}$, $dz=5\text{mm}$

Reference Value = 163.5 V/m; Power Drift = 0.01 dB

Peak SAR (extrapolated) = 73.9 W/kg

SAR(1 g) = 39 W/kg; SAR(10 g) = 19.6 W/kg

Maximum value of SAR (measured) = 43.8 W/kg

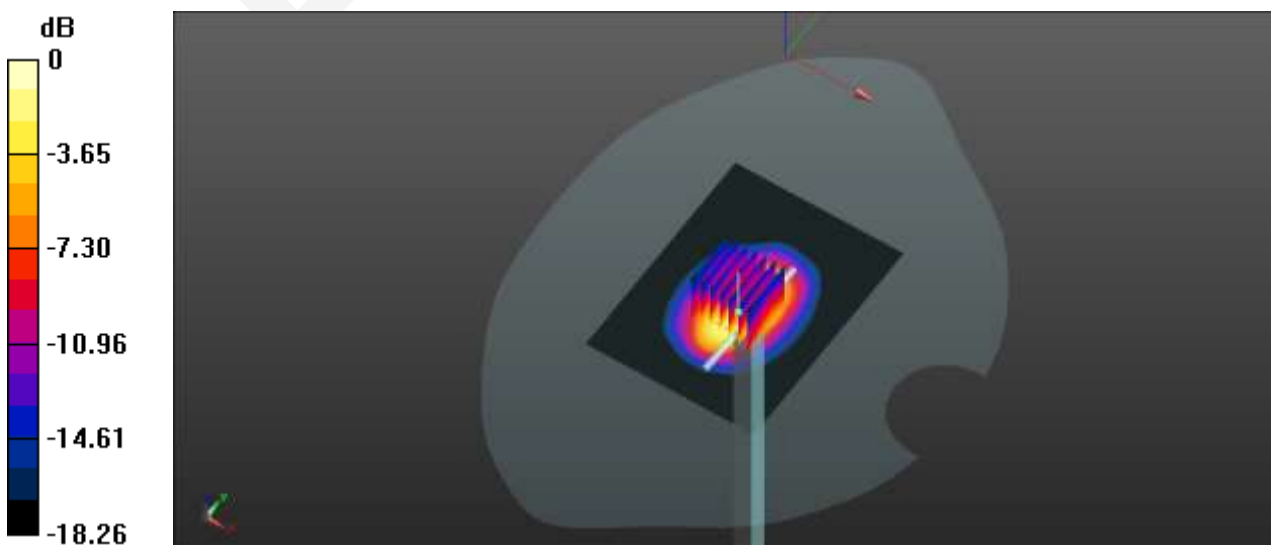

0 dB = 43.8 W/kg = 16.41 dBW/kg

EUT TEST STRATEGY AND METHODOLOGY

Test Positions for Device Operating Next to a Person’s Ear

This category includes most wireless handsets with fixed, retractable or internal antennas located toward the top half of the device, with or without a foldout, sliding or similar keypad cover. The handset should have its earpiece located within the upper ¼ of the device, either along the centerline or off-centered, as perceived by its users. This type of handset should be positioned in a normal operating position with the “test device reference point” located along the “vertical centerline” on the front of the device aligned to the “ear reference point”. The “test device reference point” should be located at the same level as the center of the earpiece region. The “vertical centerline” should bisect the front surface of the handset at its top and bottom edges. A “ear reference point” is located on the outer surface of the head phantom on each ear spacer. It is located 1.5 cm above the center of the ear canal entrance in the “phantom reference plane” defined by the three lines joining the center of each “ear reference point” (left and right) and the tip of the mouth.

A handset should be initially positioned with the earpiece region pressed against the ear spacer of a head phantom. For the SCC-34/SC-2 head phantom, the device should be positioned parallel to the “N-F” line defined along the base of the ear spacer that contains the “ear reference point”. For interim head phantoms, the device should be positioned parallel to the cheek for maximum RF energy coupling. The “test device reference point” is aligned to the “ear reference point” on the head phantom and the “vertical centerline” is aligned to the “phantom reference plane”. This is called the “initial ear position”. While maintaining these three alignments, the body of the handset is gradually adjusted to each of the following positions for evaluating SAR:

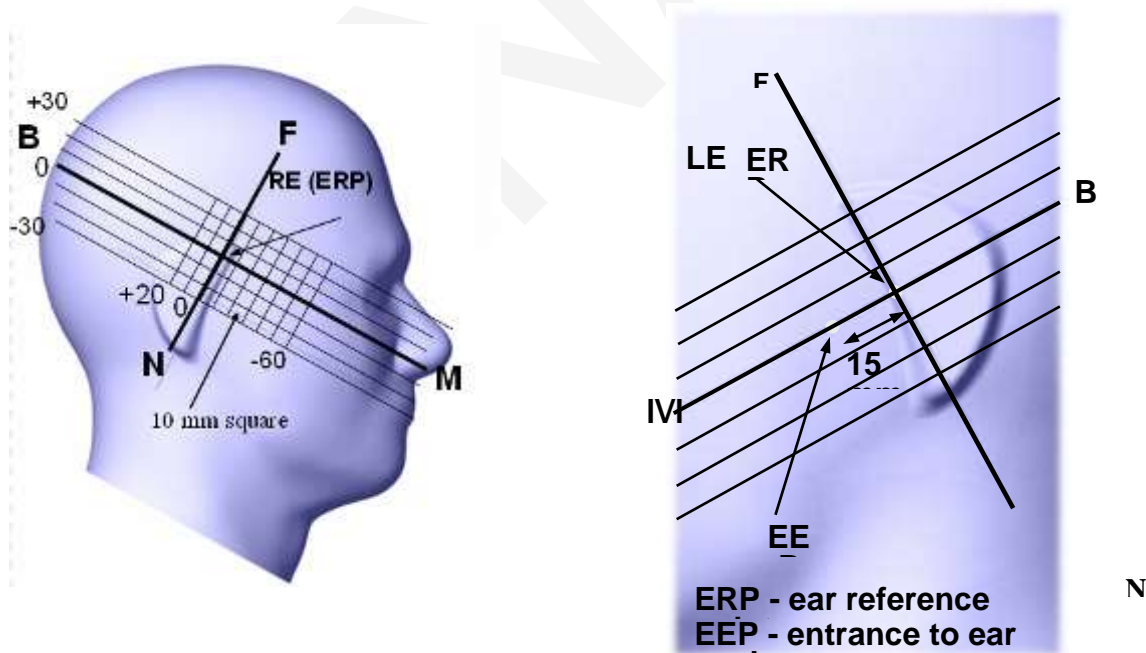

Cheek/Touch Position

The device is brought toward the mouth of the head phantom by pivoting against the “ear reference point” or along the “N-F” line for the SCC-34/SC-2 head phantom.

This test position is established:

When any point on the display, keypad or mouthpiece portions of the handset is in contact with the phantom.

(or) When any portion of a foldout, sliding or similar keypad cover opened to its intended self-adjusting normal use position is in contact with the cheek or mouth of the phantom.

For existing head phantoms – when the handset loses contact with the phantom at the pivoting point, rotation should continue until the device touches the cheek of the phantom or breaks its last contact from the ear spacer.

Cheek /Touch Position

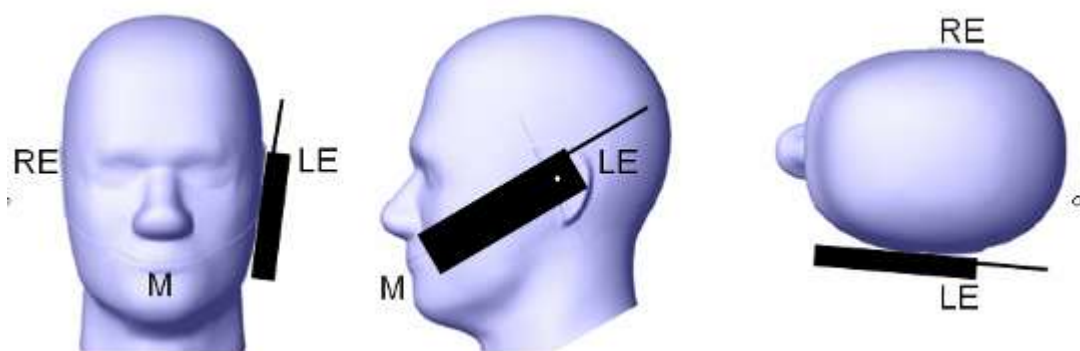

Ear/Tilt Position

With the handset aligned in the “Cheek/Touch Position”:

1) If the earpiece of the handset is not in full contact with the phantom’s ear spacer (in the “Cheek/Touch position”) and the peak SAR location for the “Cheek/Touch” position is located at the ear spacer region or corresponds to the earpiece region of the handset, the device should be returned to the “initial ear position” by rotating it away from the mouth until the earpiece is in full contact with the ear spacer.

2) (Otherwise)The handset should be moved (translated) away from the cheek perpendicular to the line passes through both “ear reference points” (note: one of these ear reference points may not physically exist on a split head model) for approximate 2-3 cm. While it is in this position, the device handset is tilted away from the mouth with respect to the “test device reference point” until the inside angle between the vertical centerline on the front surface of the phone and the horizontal line passing through the ear reference point is by 15 80 °. After the tilt, it is then moved (translated) back toward the head perpendicular to the line passes through both “ear reference points” until the device touches the phantom or the ear spacer. If the antenna touches the head first, the positioning process should be repeated with a tilt angle less than 15 ° so that the device and its antenna would touch the phantom simultaneously. This test position may require a device holder or positioner to achieve the translation and tilting with acceptable positioning repeatability.

If a device is also designed to transmit with its keypad cover closed for operating in the head position, such positions should also be considered in the SAR evaluation. The device should be tested on the left and right side of the head phantom in the “Cheek/Touch” and “Ear/Tilt” positions. When applicable, each configuration should be tested with the antenna in its fully extended and fully retracted positions. These test configurations should be tested at the high, middle and low frequency channels of each operating mode; for example, AMPS, CDMA, and TDMA. If the SAR measured at the middle channel for each test configuration (left, right, Cheek/Touch, Tilt/Ear, extended and retracted) is at least 2.0 dB lower than the SAR limit, testing at the high and low channels is optional for such test configuration(s). If the transmission band of the test device is less than 10 MHz, testing at the high and low frequency channels is optional.

Ear /Tilt 15° Position

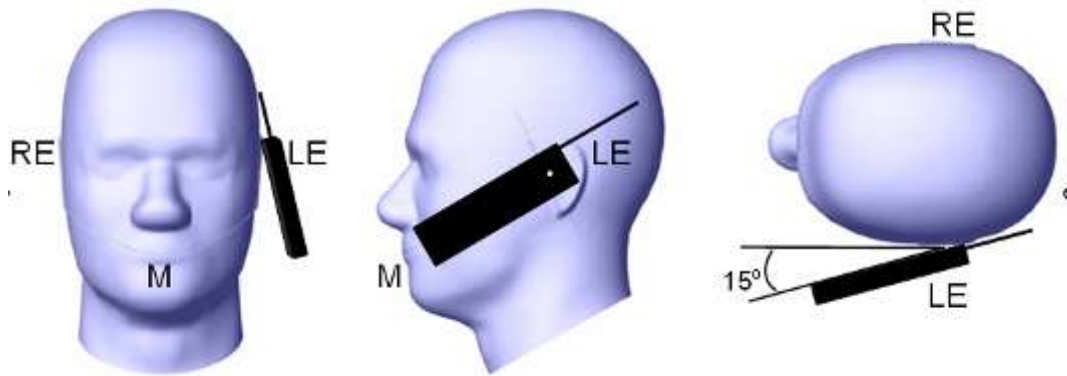

Test positions for body-worn and other configurations

Body-worn operating configurations should be tested with the belt-clips and holsters attached to the device and positioned against a flat phantom in normal use configurations. Devices with a headset output should be tested with a headset connected to the device. When multiple accessories that do not contain metallic components are supplied with the device, the device may be tested with only the accessory that dictates the closest spacing to the body. When multiple accessories that contain metallic components are supplied with the device, the device must be tested with each accessory that contains a unique metallic component. If multiple accessories share an identical metallic component (e.g., the same metallic belt-clip used with different holsters with no other metallic components), only the accessory that dictates the closest spacing to the body must be tested.

Body-worn accessories may not always be supplied or available as options for some devices that are intended to be authorized for body-worn use. A separation distance of 1.5 cm between the back of the device and a flat phantom is recommended for testing body-worn SAR compliance under such circumstances. Other separation distances may be used, but they should not exceed 2.5 cm. In these cases, the device may use body-worn accessories that provide a separation distance greater than that tested for the device provided however that the accessory contains no metallic components.

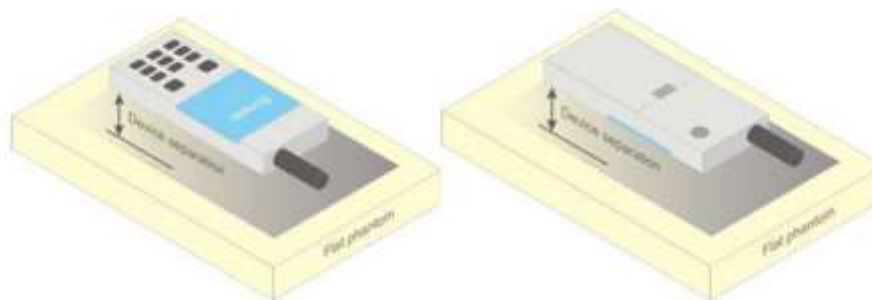

Figure 5 – Test positions for body-worn devices

SAR Evaluation Procedure

The evaluation was performed with the following procedure:

Step 1: Measurement of the SAR value at a fixed location above the ear point or central position was used as a reference value for assessing the power drop. The SAR at this point is measured at the start of the test and then again at the end of the testing.

Step 2: The SAR distribution at the exposed side of the head was measured at a distance of 4 mm from the inner surface of the shell. The area covered the entire dimension of the head or EUT and the horizontal grid spacing was 10 mm x 10 mm. Based on these data, the area of the maximum absorption was determined by spline interpolation. The first Area Scan covers the entire dimension of the EUT to ensure that the hotspot was correctly identified.

Step 3: Around this point, a volume of 30 mm x 30 mm x 30 mm was assessed by measuring 7x 7 x 7 points. On the basis of this data set, the spatial peak SAR value was evaluated under the following procedure:

- 1) The data at the surface were extrapolated, since the center of the dipoles is 1.2 mm away from the tip of the probe and the distance between the surface and the lowest measuring point is 1.3 mm. The extrapolation was based on a least square algorithm. A polynomial of the fourth order was calculated through the points in z-axis. This polynomial was then used to evaluate the points between the surface and the probe tip.
- 2) The maximum interpolated value was searched with a straightforward algorithm. Around this maximum the SAR values averaged over the spatial volumes (1 g or 10 g) were computed by the 3D-Spline interpolation algorithm. The 3D-Spline is composed of three one dimensional splines with the "Not a knot"-condition (in x, y and z-directions). The volume was integrated with the trapezoidal-algorithm. One thousand points (10 x 10 x 10) were interpolated to calculate the averages.

All neighboring volumes were evaluated until no neighboring volume with a higher average value was found.

Step 4: Re-measurement of the SAR value at the same location as in Step 1. If the value changed by more than 5%, the evaluation was repeated.

Test methodology

KDB 447498 D01 General RF Exposure Guidance v05r02.
KDB 648474 D04 Handset SAR v01r02.
KDB 865664 D01 SAR measurement 100 MHz to 6 GHz v01r04
KDB 865664 D02 RF Exposure Reporting v01r01
KDB 941225 D01 3G SAR Procedures v03
KDB 941225 D06 Hotspot Mode v02

CONDUCTED OUTPUT POWER MEASUREMENT

Provision Applicable

The measured peak output power should be greater and within 5% than EMI measurement.

Test Procedure

The RF output of the transmitter was connected to the input of the EMI Test Receiver through sufficient attenuation.

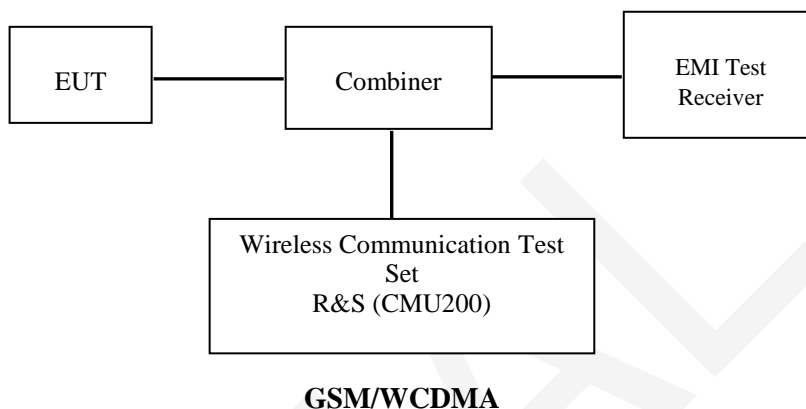

Radio Configuration

The power measurement was configured by the Wireless Communication Test Set CMU200 for all Radio configurations except the HSPA+/DC-HSDPA configured by E5515C.

GSM

Function: Menu select > GSM Mobile Station > GSM 850/1900

Press Connection control to choose the different menus

Press RESET > choose all the reset all settings

Connection: Press Signal Off to turn off the signal and change settings

Network Support > GSM + only

MS Signal

> 33 dBm for GSM 850

> 30 dBm for GSM 1900

BS Signal: Enter the same channel number for TCH channel (test channel) and BCCH channel

Frequency Offset >+ 0 Hz

Mode > BCCH and TCH

BCCH Level > -85 dBm (May need to adjust if link is not stable)

BCCH Channel > choose desired test channel [Enter the same channel number for TCH channel (test channel) and BCCH channel]

Channel Type > Off

P0 > 4 dB

TCH > choose desired test channel

Hopping > Off

AF/RF: Enter appropriate offsets for Ext. Att. Output and Ext. Att. Input

Connection: Press Signal on to turn on the signal and change settings

GPRS

Function: Menu select > GSM Mobile Station > GSM 850/1900
 Press Connection control to choose the different menus
 Press RESET > choose all the reset all settings
 Connection: Press Signal Off to turn off the signal and change settings
 Network Support > GSM + GPRS or GSM + EGSM
 Main Service > Packet Data

Service selection > Test Mode A – Auto Slot Config. off
 MS Signal: Press Slot Config Bottom on the right twice to select and change the number of time slots and power setting
 > Slot configuration > Uplink/Gamma
 > 33 dBm for GPRS 850
 > 30 dBm for GPRS 1900

BS Signal: Enter the same channel number for TCH channel (test channel) and BCCH channel
 Frequency Offset >+ 0 Hz
 Mode >BCCH and TCH
 BCCH Level >-85 dBm (May need to adjust if link is not stable)
 BCCH Channel > choose desire test channel [Enter the same channel number for TCH channel (test channel) and BCCH channel]

Channel Type > Off
 P0 > 4 dB
 Slot Config > Unchanged (if already set under MS signal)
 TCH > choose desired test channel
 Hopping >Off
 Main Timeslot >3
 Network: Coding Scheme >CS4 (GPRS)
 Bit Stream >2E9-1 PSR Bit Stream
 AF/RF: Enter appropriate offsets for Ext. Att. Output and Ext. Att. Input
 Connection: Press Signal on to turn on the signal and change settings

WCDMA Release 99

The following tests were conducted according to the test requirements outlines in section 5.2 of the 3GPP TS34.121-1 specification. The EUT has a nominal maximum output power of 24dBm (+1.7/-3.7).

WCDMA General Settings	Loopback Mode	Test Mode 1
	Rel99 RMC	12.2kbps RMC
	Power Control Algorithm	Algorithm2
	β_c / β_d	8/15

HSDPA

The following tests were conducted according to the test requirements outlines in section 5.2 of the 3GPP TS34.121-1 specification.

	Mode	HSDPA	HSDPA	HSDPA	HSDPA
	Subset	1	2	3	4
WCDMA General Settings	Loopback Mode	Test Mode 1			
	Rel99 RMC	12.2kbps RMC			
	HSDPA FRC	H-Set1			
	Power Control Algorithm	Algorithm2			
	β_c	2/15	12/15	15/15	15/15
	β_d	15/15	15/15	8/15	4/15
	β_d (SF)	64			
	β_c / β_d	2/15	12/15	15/8	15/4
	β_{hs}	4/15	24/15	30/15	30/15
MPR(dB)	0	0	0.5	0.5	
HSDPA Specific Settings	DACK	8			
	DNAK	8			
	DCQI	8			
	Ack-Nack repetition factor	3			
	CQI Feedback	4ms			
	CQI Repetition Factor	2			
	$A_{hs} = \beta_{hs} / \beta_c$	30/15			

HSUPA

The following tests were conducted according to the test requirements outlines in section 5.2 of the 3GPP TS34.121-1 specification.

	Mode	HSUPA	HSUPA	HSUPA	HSUPA	HSUPA
	Subset	1	2	3	4	5
WCDMA A General Settings	Loopback Mode	Test Mode 1				
	Rel99 RMC	12.2kbps RMC				
	HSDPA FRC	H-Set1				
	HSUPA Test	HSUPA Loopback				
	Power Control Algorithm	Algorithm2				
	β_c	11/15	6/15	15/15	2/15	15/15
	β_d	15/15	15/15	9/15	15/15	0
	β_{ec}	209/225	12/15	30/15	2/15	5/15
	β_c / β_d	11/15	6/15	15/9	2/15	-
	β_{hs}	22/15	12/15	30/15	4/15	5/15
	CM(dB)	1.0	3.0	2.0	3.0	1.0
MPR(dB)	0	2	1	2	0	
HSDPA Specific Settings	DACK	8				
	DNAK	8				
	DCQI	8				
	Ack-Nack repetition factor	3				
	CQI Feedback	4ms				
	CQI Repetition Factor	2				
	$A_{hs} = \beta_{hs} / \beta_c$	30/15				
HSUPA Specific Settings	DE-DPCCH	6	8	8	5	7
	DHARQ	0	0	0	0	0
	AG Index	20	12	15	17	21
	ETFCI	75	67	92	71	81
	Associated Max UL Data Rate kbps	242.1	174.9	482.8	205.8	308.9
	Reference E_FCI	E-TFCI 11 E E-TFCI PO 4 E-TFCI 67 E-TFCI PO 18 E-TFCI 71 E-TFCI PO23 E-TFCI 75 E-TFCI PO26 E-TFCI 81 E-TFCI PO 27	E-TFCI 11 E-TFCI PO4 E-TFCI 92 E-TFCI PO 18	E-TFCI 11 E E-TFCI PO 4 E-TFCI 67 E-TFCI PO 18 E-TFCI 71 E-TFCI PO23 E-TFCI 75 E-TFCI PO26 E-TFCI 81 E-TFCI PO 27		

HSPA+

The following tests were conducted according to the test requirements in Table C.11.1.4 of 3GPP TS 34.121-1

Sub-test	β_c (Note3)	β_d	β_{HS} (Note1)	β_{ec}	β_{ed} (2xSF2) (Note 4)	β_{ed} (2xSF4) (Note 4)	CM (dB) (Note 2)	MPR (dB) (Note 2)	AG Index (Note 4)	E-TFCI (Note 5)	E-TFCI (boost)
1	1	0	30/15	30/15	β_{ed1} : 30/15 β_{ed2} : 30/15	β_{ed3} : 24/15 β_{ed4} : 24/15	3.5	2.5	14	105	105

Note 1: $\Delta_{ACK}, \Delta_{NACK}$ and $\Delta_{CQI} = 30/15$ with $\beta_{hs} = 30/15 * \beta_c$.

Note 2: CM = 3.5 and the MPR is based on the relative CM difference, MPR = MAX(CM-1,0).

Note 3: DPDCH is not configured, therefore the β_c is set to 1 and $\beta_d = 0$ by default.

Note 4: β_{ed} can not be set directly; it is set by Absolute Grant Value.

Note 5: All the sub-tests require the UE to transmit 2SF2+2SF4 16QAM EDCH and they apply for UE using E-DPDCH category 7. E-DCH TTI is set to 2ms TTI and E-DCH table index = 2. To support these E-DCH configurations DPDCH is not allocated. The UE is signalled to use the extrapolation algorithm.

DC-HSDPA

The following tests were conducted according to the test requirements in Table Table C.8.1.12 of 3GPP TS 34.121-1

Table C.8.1.12: Fixed Reference Channel H-Set 12

Parameter	Unit	Value
Nominal Avg. Inf. Bit Rate	kbps	60
Inter-TTI Distance	TTI's	1
Number of HARQ Processes	Processes	6
Information Bit Payload (N_{BF})	Bits	120
Number Code Blocks	Blocks	1
Binary Channel Bits Per TTI	Bits	960
Total Available SML's in UE	SML's	19200
Number of SML's per HARQ Proc.	SML's	3200
Coding Rate		0.15
Number of Physical Channel Codes	Codes	1
Modulation		QPSK

Note 1: The RMC is intended to be used for DC-HSDPA mode and both cells shall transmit with identical parameters as listed in the table.

Note 2: Maximum number of transmission is limited to 1, i.e., retransmission is not allowed. The redundancy and constellation version 0 shall be used.

Maximum Target Output Power

Max Target Power (dBm)			
Mode/Band	Channel		
	Low	Middle	High
GSM 850	33.4	33.4	33.4
GPRS 1 TX Slot	33	33	33
GPRS 2 TX Slot	31.2	31.2	31.2
GPRS 3 TX Slot	30.1	30.1	30.1
GPRS 4 TX Slot	29.5	29.5	29.5
EDGE 1 TX Slot	26.5	26.5	26.5
EDGE 2 TX Slot	25.1	25.1	25.1
EDGE 3 TX Slot	22.9	22.9	22.9
EDGE 4 TX Slot	21.5	21.5	21.5
GSM 1900	28.6	28.6	28.6
GPRS 1 TX Slot	28.4	28.4	28.4
GPRS 2 TX Slot	27.4	27.4	27.4
GPRS 3 TX Slot	26.3	26.3	26.3
GPRS 4 TX Slot	24.4	24.4	24.4
EDGE 1 TX Slot	25.2	25.2	25.2
EDGE 2 TX Slot	23.8	23.8	23.8
EDGE 3 TX Slot	22.5	22.5	22.5
EDGE 4 TX Slot	20.9	20.9	20.9
WCDMA850	22.6	22.6	22.6
HSDPA	21.9	21.9	21.9
HSUPA	21.7	21.7	21.7
DC-HSDPA	21.1	21.1	21.1
HSPA+	21.1	21.1	21.1
WCDMA1900	23.1	23.1	23.1
HSDPA	22.3	22.3	22.3
HSUPA	22.4	22.4	22.4
DC-HSDPA	21.8	21.8	21.8
HSPA+	21.8	21.8	21.8
WLAN	9.8	9.8	9.8
Bluetooth BDR/EDR	-4.2	-4.2	-4.2
Bluetooth LE	-10.5	-10.5	-10.5

Test Results:

GSM:

Band	Channel No.	Frequency (MHz)	RF Output Power (dBm)
GSM 850	128	824.2	33.26
	190	836.6	33.12
	251	848.8	33.31
PCS 1900	512	1850.2	28.1
	661	1880	28.41
	810	1909.8	28.46

GPRS:

Band	Channel No.	Frequency (MHz)	RF Output Power (dBm)			
			1 slot	2 slots	3 slots	4 slots
GSM 850	128	824.2	32.85	31.09	29.98	28.95
	190	836.6	32.71	31.1	29.87	29.03
	251	848.8	32.81	31.13	29.93	29.41
PCS 1900	512	1850.2	27.99	27.03	25.8	23.88
	661	1880	28.31	27.27	26.24	24.05
	810	1909.8	28.27	27.25	25.93	24.26

EGPRS:

Band	Channel No.	Frequency (MHz)	RF Output Power (dBm)			
			1 slot	2 slots	3 slots	4 slots
GSM 850	128	824.2	26.36	24.79	22.66	21.36
	190	836.6	26.24	24.74	22.77	21.23
	251	848.8	26.27	24.98	22.73	21.24
PCS 1900	512	1850.2	24.99	23.64	22.35	20.68
	661	1880	25.08	23.69	22.22	20.62
	810	1909.8	24.99	23.65	22.26	20.79

For SAR, the time based average power is relevant, the difference in between depends on the duty cycle of the TDMA signal.

Number of Time slot	1	2	3	4
Duty Cycle	1:8	1:4	1:2.66	1:2
Time based Ave. power compared to slotted Ave. power	-9 dB	-6 dB	-4.25 dB	-3 dB
Crest Factor	8	4	2.66	2

The time based average power for GPRS

Band	Channel No.	Frequency (MHz)	Time based average Power (dBm)			
			1 slot	2 slot	3 slots	4 slots
GSM 850	128	824.2	23.85	25.09	25.73	25.95
	190	836.6	23.71	25.1	25.62	26.03
	251	848.8	23.81	25.13	25.68	26.41
PCS 1900	512	1850.2	18.99	21.03	21.55	20.88
	661	1880	19.31	21.27	21.99	21.05
	810	1909.8	19.27	21.25	21.68	21.26

The time based average power for EGPRS

Band	Channel No.	Frequency (MHz)	Time based average Power (dBm)			
			1 slot	2 slot	3 slots	4 slots
GSM 850	128	824.2	17.36	18.79	18.41	18.36
	190	836.6	17.24	18.74	18.52	18.23
	251	848.8	17.27	18.98	18.48	18.24
PCS 1900	512	1850.2	15.99	17.64	18.1	17.68
	661	1880	16.08	17.69	17.97	17.62
	810	1909.8	15.99	17.65	18.01	17.79

Note:

- 1.Rohde & Schwarz Radio Communication Tester (CMU200) was used for the measurement of GSM peak and average output power for active timeslots.
- 2.For GSM voice, 1 timeslot has been activated with power level 5 (850 MHz band) and 0 (1900 MHz band).
- 3.For GPRS, 1, 2, 3 and 4 timeslots has been activated separately with power level 3(850 MHz band) and 3(1900 MHz band).
- 4.According to KDB941225D06-SAR for EGPRS mode are not required when the source-based time-averaged output power for data mode is lower than that in the normal GPRS mode

WCDMA:

Results (12.2kbps RMC)

Band	Channel No.	Frequency (MHz)	RF Output Power (dBm)
WCDMA 850	4132	826.4	22.46
	4183	836.6	21.77
	4233	846.6	22.36
WCDMA 1900	9262	1852.4	22.5
	9400	1880	22.82
	9538	1907.6	23

Results (HSDPA)

Band	Channel No.	Frequency (MHz)	RF Output Power (dBm)			
			Subset 1	Subset 2	Subset 3	Subset 4
WCDMA 850	4132	826.4	21.54	21.75	21.35	21.65
	4183	836.6	20.78	20.92	20.67	20.6
	4233	846.6	21.41	21.52	21.56	21.51
WCDMA 1900	9262	1852.4	21.76	21.68	21.71	21.7
	9400	1880	22.04	22.15	22.12	22.16
	9538	1907.6	22.15	22.17	22.18	22.24

Results (HSUPA)

Band	Channel No.	Frequency (MHz)	RF Output Power (dBm)				
			Subset 1	Subset 2	Subset 3	Subset 4	Subset 5
WCDMA 850	4132	826.4	21.42	21.64	21.4	21.48	21.45
	4183	836.6	20.8	20.62	20.67	20.67	20.92
	4233	846.6	21.34	21.45	21.55	21.35	21.5
WCDMA 1900	9262	1852.4	21.73	21.78	21.8	21.71	21.7
	9400	1880	22.07	22.03	21.99	22.06	22.1
	9538	1907.6	22.19	22.27	22.21	22.26	22.27

DC-HSDPA

Band	Channel No.	Frequency (MHz)	RF Output Power (dBm)			
			Subset 1	Subset 2	Subset 3	Subset 4
WCDMA 850	4132	826.4	20.98	20.94	20.89	20.95
	4183	836.6	20.33	20.28	20.38	20.41
	4233	846.6	20.87	20.96	21.01	20.95
WCDMA 1900	9262	1852.4	21.17	21.19	21.14	21.22
	9400	1880	21.58	21.44	21.6	21.59
	9538	1907.6	21.63	21.69	21.61	21.68

HSPA+

Band	Channel No.	Frequency (MHz)	RF Output Power (dBm)
WCDMA 850	4132	826.4	20.93
	4183	836.6	20.37
	4233	846.6	21.01
WCDMA 1900	9262	1852.4	21.12
	9400	1880	21.54
	9538	1907.6	21.7

Note:

1. The default test configuration is to measure SAR with an established radio link between the EUT and a communication test set using a 12.2 kbps RMC (reference measurement Channel) Configured in Test Loop Model 1.
2. KDB 941225 D01-Body SAR is not required for HSDPA/HSUPA when the maximum average output of each RF channel is less than ¼ dB higher than measured 12.2kbps RMC or the maximum SAR for 12.2kbps RMC is < 75% of SAR limit.

Bluetooth

Mode	Channel No.	Channel frequency (MHz)	RF Output Power (dBm)
BDR(GFSK)	0	2402	-4.5
	39	2441	-4.38
	78	2480	-4.25
EDR(4-DQPSK)	0	2402	-4.92
	39	2441	-4.77
	78	2480	-4.62
EDR-8DPSK	0	2402	-4.59
	39	2441	-4.44
	78	2480	-4.34
BLE	0	2402	-10.63
	19	2440	-10.55
	39	2480	-10.81

WLAN

Mode	Channel No.	Channel frequency (MHz)	RF Output Power (dBm)
802.11b	1	2412	9.26
	6	2437	9.68
	11	2462	9.55
802.11g	1	2412	9.23
	6	2437	9.02
	11	2462	8.76
802.11n HT20	1	2412	9.15
	6	2437	9.48
	11	2462	9.09
802.11n HT40	3	2422	8.79
	6	2437	8.73
	9	2452	9.07

Note:

1. The output power was tested under data rate 1Mbps for 802.11b, 6Mbps for 802.11g, 6.5Mbps for 802.11n HT20, 13.5Mbps for 802.11n HT40.

SAR MEASUREMENT RESULTS

This page summarizes the results of the performed dosimetric evaluation.

The EUT is capable of function as a WLAN to cellular mobile hotspot. Additional SAR test was performed according to KDB941225 D06. Test was performed with a separation of 1cm between the EUT and the flat phantom. The EUT was positioned for SAR tests with the front and back surfaces facing the edge. Each transmit band was utilized for SAR testing. The tested mode has been selected within each band that exhibits the highest time average output power.

SAR Test Data

Environmental Conditions

Temperature:	22-23	21.5-22.5
Relative Humidity:	30 %	30 %
ATM Pressure:	1002 mbar	999 mbar
Recorded Date:	2015-08-12	2015-08-13

Testing was performed by Rocky Xiao

GSM 850:

EUT Position	Frequency (MHz)	Test Mode	Power Drift (%)	Max. Meas. Power (dBm)	Max. Rated Power (dBm)	1g SAR (W/Kg)			
						Scaled Factor	Meas. SAR	Scaled SAR	Plot
Left Head Cheek	824.2	GSM	-0.453	33.26	33.4	1.033	0.0823	0.085	/
	836.6	GSM	3.444	33.12	33.4	1.067	0.074	0.079	/
	848.8	GSM	-1.599	33.31	33.4	1.021	0.085	0.087	1#
Left Head Tilt	824.2	GSM	/	/	/	/	/	/	/
	836.6	GSM	1.795	33.12	33.4	1.067	0.0625	0.067	/
	848.8	GSM	/	/	/	/	/	/	/
Right Head Cheek	824.2	GSM	/	/	/	/	/	/	/
	836.6	GSM	-2.106	33.12	33.4	1.067	0.0712	0.076	/
	848.8	GSM	/	/	/	/	/	/	/
Right Head Tilt	824.2	GSM	/	/	/	/	/	/	/
	836.6	GSM	-2.125	33.12	33.4	1.067	0.058	0.062	/
	848.8	GSM	/	/	/	/	/	/	/
Body Worm Headset (10mm)	824.2	GSM	/	/	/	/	/	/	/
	836.6	GSM	-0.214	33.12	33.4	1.067	0.363	0.387	/
	848.8	GSM	/	/	/	/	/	/	/
Body Worm Bottom (10mm)	824.2	GPRS	/	/	/	/	/	/	/
	836.6	GPRS	3.158	29.03	29.5	1.114	0.103	0.115	/
	848.8	GPRS	/	/	/	/	/	/	/
Body Worm Left (10mm)	824.2	GPRS	/	/	/	/	/	/	/
	836.6	GPRS	1.211	29.03	29.5	1.114	0.042	0.047	/
	848.8	GPRS	/	/	/	/	/	/	/
Body Worm Right (10mm)	824.2	GPRS	/	/	/	/	/	/	/
	836.6	GPRS	-1.725	29.03	29.5	1.114	0.0221	0.025	/
	848.8	GPRS	/	/	/	/	/	/	/
Body Worm Back (10mm)	824.2	GPRS	2.566	28.95	29.5	1.135	0.411	0.466	/
	836.6	GPRS	-0.791	29.03	29.5	1.114	0.432	0.481	/
	848.8	GPRS	-2.051	29.41	29.5	1.021	0.486	0.496	2#

Note:

1. When the 1-g SAR is $\leq 0.8\text{W/Kg}$, testing for other channels are optional.
2. The EUT transmit and receive through the same GSM antenna while testing SAR.
3. When SAR or MPE is not measured at the maximum power level allowed for production units, the results must be scaled to the maximum tune-up tolerance limit according to the power applied to the individual channels tested to determine compliance.
4. When the maximum output power variation across the required test channels is $> \frac{1}{2}$ dB, instead of the middle channel, the highest output power channel must be used.
5. The Multi-slot Classes of EUT is Class 12 which has maximum 4 Downlink slots and 4 Uplink slots, the maximum active slots is 5, when perform the multiple slots scan, 1DL+4UL is the worst case.

PCS Band:

EUT Position	Frequency (MHz)	Test Mode	Power Drift (%)	Max. Meas. Power (dBm)	Max. Rated Power (dBm)	1g SAR (W/Kg)			
						Scaled Factor	Meas. SAR	Scaled SAR	Plot
Left Head Cheek	1850.2	GSM	/	/	/	/	/	/	/
	1880	GSM	-1.187	28.41	28.6	1.045	0.0918	0.096	/
	1909.8	GSM	/	/	/	/	/	/	/
Left Head Tilt	1850.2	GSM	/	/	/	/	/	/	/
	1880	GSM	-2.156	28.41	28.6	1.045	0.0672	0.07	/
	1909.8	GSM	/	/	/	/	/	/	/
Right Head Cheek	1850.2	GSM	-0.328	28.1	28.6	1.122	0.106	0.119	/
	1880	GSM	-3.241	28.41	28.6	1.045	0.112	0.117	/
	1909.8	GSM	3.039	28.46	28.6	1.033	0.13	0.134	3#
Right Head Tilt	1850.2	GSM	/	/	/	/	/	/	/
	1880	GSM	-2.334	28.41	28.6	1.045	0.055	0.057	/
	1909.8	GSM	/	/	/	/	/	/	/
Body Worm Headset (10mm)	1850.2	GSM	/	/	/	/	/	/	/
	1880	GSM	2.427	28.41	28.6	1.045	0.712	0.744	/
	1909.8	GSM	/	/	/	/	/	/	/
Body Worm Bottom (10mm)	1850.2	GPRS	/	/	/	/	/	/	/
	1880	GPRS	-2.533	26.24	26.3	1.014	0.663	0.672	/
	1909.8	GPRS	/	/	/	/	/	/	/
Body Worm Left (10mm)	1850.2	GPRS	/	/	/	/	/	/	/
	1880	GPRS	0.691	26.24	26.3	1.014	0.336	0.341	/
	1909.8	GPRS	/	/	/	/	/	/	/
Body Worm Right (10mm)	1850.2	GPRS	/	/	/	/	/	/	/
	1880	GPRS	3.603	26.24	26.3	1.014	0.114	0.116	/
	1909.8	GPRS	/	/	/	/	/	/	/
Body Worm Back (10mm)	1850.2	GPRS	-0.94	25.8	26.3	1.122	0.827	0.928	/
	1880	GPRS	-4.06	26.24	26.3	1.014	0.922	0.935	4#
	1909.8	GPRS	3.257	25.93	26.3	1.089	0.802	0.873	/

Note:

1. When the 1-g SAR is $\leq 0.8\text{W/Kg}$, testing for other channels are optional.
2. The EUT transmit and receive through the same GSM antenna while testing SAR.
3. When SAR or MPE is not measured at the maximum power level allowed for production units, the results must be scaled to the maximum tune-up tolerance limit according to the power applied to the individual channels tested to determine compliance.
4. When the maximum output power variation across the required test channels is $> \frac{1}{2}$ dB, instead of the middle channel, the highest output power channel must be used.
5. The Multi-slot Classes of EUT is Class 12 which has maximum 4 Downlink slots and 4 Uplink slots, the maximum active slots is 5, when perform the multiple slots scan, 2DL+3UL is the worst case.

WCDMA 850 Band:

EUT Position	Frequency (MHz)	Test Mode	Power Drift (%)	Max. Meas. Power (dBm)	Max. Rated Power (dBm)	1g SAR (W/Kg)			
						Scaled Factor	Meas. SAR	Scaled SAR	Plot
Left Head Cheek	826.4	RMC	0.231	22.46	22.6	1.033	0.068	0.07	5#
	836.6	RMC	3.667	21.77	22.6	1.211	0.054	0.065	/
	846.6	RMC	3.204	22.36	22.6	1.057	0.0625	0.066	/
Left Head Tilt	826.4	RMC	1.634	22.46	22.6	1.033	0.0447	0.046	/
	836.6	RMC	/	/	/	/	/	/	/
	846.6	RMC	/	/	/	/	/	/	/
Right Head Cheek	826.4	RMC	-1.044	22.46	22.6	1.033	0.0619	0.064	/
	836.6	RMC	/	/	/	/	/	/	/
	846.6	RMC	/	/	/	/	/	/	/
Right Head Tilt	826.4	RMC	-2.38	22.46	22.6	1.033	0.0401	0.041	/
	836.6	RMC	/	/	/	/	/	/	/
	846.6	RMC	/	/	/	/	/	/	/
Body Worm Bottom (10mm)	826.4	RMC	1.779	22.46	22.6	1.033	0.0361	0.037	/
	836.6	RMC	/	/	/	/	/	/	/
	846.6	RMC	/	/	/	/	/	/	/
Body Worm Left (10mm)	826.4	RMC	3.401	22.46	22.6	1.033	0.0303	0.031	/
	836.6	RMC	/	/	/	/	/	/	/
	846.6	RMC	/	/	/	/	/	/	/
Body Worm Right (10mm)	826.4	RMC	2.996	22.46	22.6	1.033	0.014	0.014	/
	836.6	RMC	/	/	/	/	/	/	/
	846.6	RMC	/	/	/	/	/	/	/
Body Worm Back (10mm)	826.4	RMC	-2.725	22.46	22.6	1.033	0.295	0.305	6#
	836.6	RMC	2.765	21.77	22.6	1.211	0.24	0.291	/
	846.6	RMC	2.046	22.36	22.6	1.057	0.281	0.297	/

Note:

1. When the 1-g SAR is $\leq 0.8W/Kg$, testing for other channels are optional.
2. The EUT transmit and receive through the same antenna while testing SAR.
3. The default test configuration is to measure SAR with an established radio link between the EUT and a communication test set using a 12.2 kbps RMC (reference measurement Channel) Configured in Test Loop Model.
4. KDB 941225 D01-Body SAR is not required for HSDPA/HSUPA/HSPA+/DC-HSDPA when the maximum average output of each RF channel is less than 1/4 dB higher than measured 12.2kbps RMC or the maximum SAR for 12.2kbps RMC is < 75% of SAR limit.
5. When SAR or MPE is not measured at the maximum power level allowed for production units, the results must be scaled to the maximum tune-up tolerance limit according to the power applied to the individual channels tested to determine compliance.

WCDMA 1900 Band:

EUT Position	Frequency (MHz)	Test Mode	Power Drift (%)	Max. Meas. Power (dBm)	Max. Rated Power (dBm)	1g SAR (W/Kg)			
						Scaled Factor	Meas. SAR	Scaled SAR	Plot
Left Head Cheek	1922.4	RMC	/	/	/	/	/	/	/
	1950	RMC	/	/	/	/	/	/	/
	1977.6	RMC	-2.999	23	23.1	1.023	0.213	0.218	/
Left Head Tilt	1922.4	RMC	/	/	/	/	/	/	/
	1950	RMC	/	/	/	/	/	/	/
	1977.6	RMC	2.044	23	23.1	1.023	0.115	0.118	/
Right Head Cheek	1922.4	RMC	-0.461	22.5	23.1	1.148	0.202	0.232	/
	1950	RMC	-0.696	22.82	23.1	1.067	0.213	0.227	/
	1977.6	RMC	-3.395	23	23.1	1.023	0.237	0.242	7#
Right Head Tilt	1922.4	RMC	/	/	/	/	/	/	/
	1950	RMC	/	/	/	/	/	/	/
	1977.6	RMC	3.98	23	23.1	1.023	0.0932	0.095	/
Body Worm Bottom (10mm)	1922.4	RMC	/	/	/	/	/	/	/
	1950	RMC	/	/	/	/	/	/	/
	1977.6	RMC	3.01	23	23.1	1.023	0.613	0.627	/
Body Worm Left (10mm)	1922.4	RMC	/	/	/	/	/	/	/
	1950	RMC	/	/	/	/	/	/	/
	1977.6	RMC	-3.337	23	23.1	1.023	0.336	0.344	/
Body Worm Right (10mm)	1922.4	RMC	/	/	/	/	/	/	/
	1950	RMC	/	/	/	/	/	/	/
	1977.6	RMC	-3.578	23	23.1	1.023	0.0316	0.032	/
Body Worm Back (10mm)	1922.4	RMC	-3.756	22.5	23.1	1.148	0.812	0.932	/
	1950	RMC	-0.416	22.82	23.1	1.067	0.916	0.977	/
	1977.6	RMC	-0.23	23	23.1	1.023	0.975	0.997	8#

Note:

1. When the 1-g SAR is $\leq 0.8W/Kg$, testing for other channels are optional.
2. The EUT transmit and receive through the same antenna while testing SAR.
3. The default test configuration is to measure SAR with an established radio link between the EUT and a communication test set using a 12.2 kbps RMC (reference measurement Channel) Configured in Test Loop Model.
4. KDB 941225 D01-Body SAR is not required for HSDPA/HSUPA/HSPA+/DC-HSDPA when the maximum average output of each RF channel is less than 1/4 dB higher than measured 12.2kbps RMC or the maximum SAR for 12.2kbps RMC is < 75% of SAR limit.
5. When SAR or MPE is not measured at the maximum power level allowed for production units, the results must be scaled to the maximum tune-up tolerance limit according to the power applied to the individual channels tested to determine compliance.

SAR SIMULTANEOUS TRANSMISSION DESCRIPTION

BT&WLAN and GSM&3G Antennas Location:



Simultaneous Transmission:

Description of Simultaneous Transmit Capabilities			Antennas Distance (mm)
Transmitter Combination	Simultaneous?	Hotspot?	
GSM + WCDMA	×	×	0
GSM + Bluetooth	√	×	117
GSM + WLAN	√	√	117
WCDMA+ Bluetooth	√	×	117
WCDMA + WLAN	√	√	117

Standalone SAR test exclusion considerations

Mode	Frequency (MHz)	Pavg (dBm)	Pavg (mW)	Distance (mm)	Calculated value	Threshold (1-g)	SAR Test Exclusion
WLAN	2450	9.8	9.55	0	2.99	3	YES
Bluetooth	2450	-4.2	0.38	0	0.12	3	YES

NOTE:

The 1-g and 10-g SAR test exclusion thresholds for 100 MHz to 6 GHz at test separation distances ≤ 50 mm are determined by:

$$[(\text{max. power of channel, including tune-up tolerance, mW}) / (\text{min. test separation distance, mm})] \cdot [\sqrt{f(\text{GHz})}] \leq 3.0 \text{ for 1-g SAR and } \leq 7.5 \text{ for 10-g extremity SAR, where}$$

1. f(GHz) is the RF channel transmit frequency in GHz.
2. Power and distance are rounded to the nearest mW and mm before calculation.
3. The result is rounded to one decimal place for comparison.
4. When the minimum test separation distance is < 5 mm, a distance of 5 mm is applied to determine SAR test Exclusion.

Standalone SAR estimation:

Mode	Frequency (GHz)	Pavg (dBm)	Pavg (mW)	Distance (mm)	Estimated 1-g (W/kg)
WLAN Head	2450	9.8	9.55	0	0.399
WLAN Body	2450	9.8	9.55	10	0.199
BT Head	2450	-4.2	0.38	0	0.016
BT Body	2450	-4.2	0.38	10	0.008

NOTE:

When standalone SAR test exclusion applies to an antenna that transmits simultaneously with other antennas, the standalone SAR must be estimated according to following to determine simultaneous transmission SAR test exclusion:

$$[(\text{max. power of channel, including tune-up tolerance, mW}) / (\text{min. test separation distance, mm})] \cdot [\sqrt{f(\text{GHz})} / x]$$

W/kg for test separation distances ≤ 50 mm;

where x = 7.5 for 1-g SAR.

When the minimum test separation distance is < 5 mm, a distance of 5 mm is applied to determine SAR test Exclusion

Simultaneous and Hotspot SAR test exclusion considerations:

Mode (SAR1+SAR2)	Position	Reported SAR (W/kg)		ΣSAR < 1.6W/kg
		SAR1	SAR2	
GSM 850 +BT	Left Head Cheek	0.087	0.016	0.103
	Left Head Tilt	0.067	0.016	0.083
	Right Head Cheek	0.076	0.016	0.092
	Right Head Tilt	0.062	0.016	0.078
	Body-Back-Headset	0.387	0.008	0.395
	Body-Bottom	0.115	0.008	0.123
	Body-Left	0.047	0.008	0.055
	Body-Right	0.025	0.008	0.033
	Body-Back	0.496	0.008	0.504
PCS 1900+BT	Left Head Cheek	0.096	0.016	0.112
	Left Head Tilt	0.07	0.016	0.086
	Right Head Cheek	0.134	0.016	0.15
	Right Head Tilt	0.057	0.016	0.073
	Body-Back-Headset	0.744	0.008	0.752
	Body-Bottom	0.672	0.008	0.68
	Body-Left	0.341	0.008	0.349
	Body-Right	0.116	0.008	0.124
WCDMA 850 + BT	Body-Back	0.935	0.008	0.943
	Left Head Cheek	0.07	0.016	0.086
	Left Head Tilt	0.046	0.016	0.062
	Right Head Cheek	0.064	0.016	0.08
	Right Head Tilt	0.041	0.016	0.057
	Body-Bottom	0.037	0.008	0.045
	Body-Left	0.031	0.008	0.039
	Body-Right	0.014	0.008	0.022
WCDMA 1900 + BT	Body-Back	0.305	0.008	0.313
	Left Head Cheek	0.218	0.016	0.234
	Left Head Tilt	0.118	0.016	0.134
	Right Head Cheek	0.242	0.016	0.258
	Right Head Tilt	0.095	0.016	0.111
	Body-Bottom	0.627	0.008	0.635
	Body-Left	0.344	0.008	0.352
	Body-Right	0.032	0.008	0.04
Body-Back	0.997	0.008	1.005	

Mode (SAR1+SAR2)	Position	Reported SAR (W/kg)		ΣSAR < 1.6W/kg
		SAR1	SAR2	
GSM 850+ WLAN	Left Head Cheek	0.087	0.399	0.486
	Left Head Tilt	0.067	0.399	0.466
	Right Head Cheek	0.076	0.399	0.475
	Right Head Tilt	0.062	0.399	0.461
	Body Headset Back	0.387	0.199	0.586
	Body-Bottom	0.115	0.199	0.314
	Body-Left	0.047	0.199	0.246
	Body-Right	0.025	0.199	0.224
	Body-Back	0.496	0.199	0.695
PCS 1900 + WLAN	Left Head Cheek	0.096	0.399	0.495
	Left Head Tilt	0.07	0.399	0.469
	Right Head Cheek	0.134	0.399	0.533
	Right Head Tilt	0.057	0.399	0.456
	Body Headset Back	0.744	0.199	0.943
	Body-Bottom	0.672	0.199	0.871
	Body-Left	0.341	0.199	0.54
	Body-Right	0.116	0.199	0.315
	Body-Back	0.935	0.199	1.134
WCDMA 850 + WLAN	Left Head Cheek	0.07	0.399	0.469
	Left Head Tilt	0.046	0.399	0.445
	Right Head Cheek	0.064	0.399	0.463
	Right Head Tilt	0.041	0.399	0.44
	Body-Bottom	0.037	0.199	0.236
WCDMA 850 + WLAN (Hotspot)	Body-Left	0.031	0.199	0.23
	Body-Right	0.014	0.199	0.213
	Body-Back	0.305	0.199	0.504
WCDMA 1900 + WLAN	Left Head Cheek	0.218	0.399	0.617
	Left Head Tilt	0.118	0.399	0.517
	Right Head Cheek	0.242	0.399	0.641
	Right Head Tilt	0.095	0.399	0.494
	Body-Bottom	0.627	0.199	0.826
WCDMA 1900 + WLAN (Hotspot)	Body-Left	0.344	0.199	0.543
	Body-Right	0.032	0.199	0.231
	Body-Back	0.997	0.199	1.196

Note:

Hotspot mode SAR is only required for the edges within 25mm from the transmitting antenna located.

Conclusion:

Σ SAR < 1.6 W/kg therefore simultaneous transmission SAR with Volume Scans is **not** required.

SAR Plots (Summary of the Highest SAR Values)

Test Laboratory: Bay Area Compliance Labs Corp.(Dongguan)

Test Plot 1#:GSM 850 Left Cheek High Channel

DUT: Gravity 5; Type: Gravity 5

Communication System: Generic GSM; Frequency: 848.8 MHz; Duty Cycle: 1: 8

Medium parameters used: $f = 848.8 \text{ MHz}$; $\sigma = 0.896 \text{ S/m}$; $\epsilon_r = 42.7$; $\rho = 1000 \text{ kg/m}^3$

Phantom section: Left Section

DASY5 Configuration:

- Probe: EX3DV4 - SN7329; ConvF(9.52, 9.52, 9.52); Calibrated: 2015/2/5;
- Sensor-Surface: 4mm (Mechanical Surface Detection)
- Electronics: DAE4 Sn1459; Calibrated: 2015/1/26
- Phantom: SAM (30deg probe tilt) with CRP v5.0_20150321; Type: QD000P40CD; Serial: TP:1874
- Measurement SW: DASY52, Version 52.8 (8);

Head/GSM 850 Left Cheek/Area Scan (71x111x1): Interpolated grid: $dx=1.500 \text{ mm}$, $dy=1.500 \text{ mm}$

Maximum value of SAR (interpolated) = 0.0915 W/kg

Head/GSM 850 Left Cheek/Zoom Scan (7x7x7)/Cube 0: Measurement grid: $dx=5\text{mm}$, $dy=5\text{mm}$, $dz=5\text{mm}$

Reference Value = 5.603 V/m; Power Drift = -0.07 dB

Peak SAR (extrapolated) = 0.103 W/kg

SAR(1 g) = 0.085 W/kg; SAR(10 g) = 0.068 W/kg

Maximum value of SAR (measured) = 0.0890 W/kg

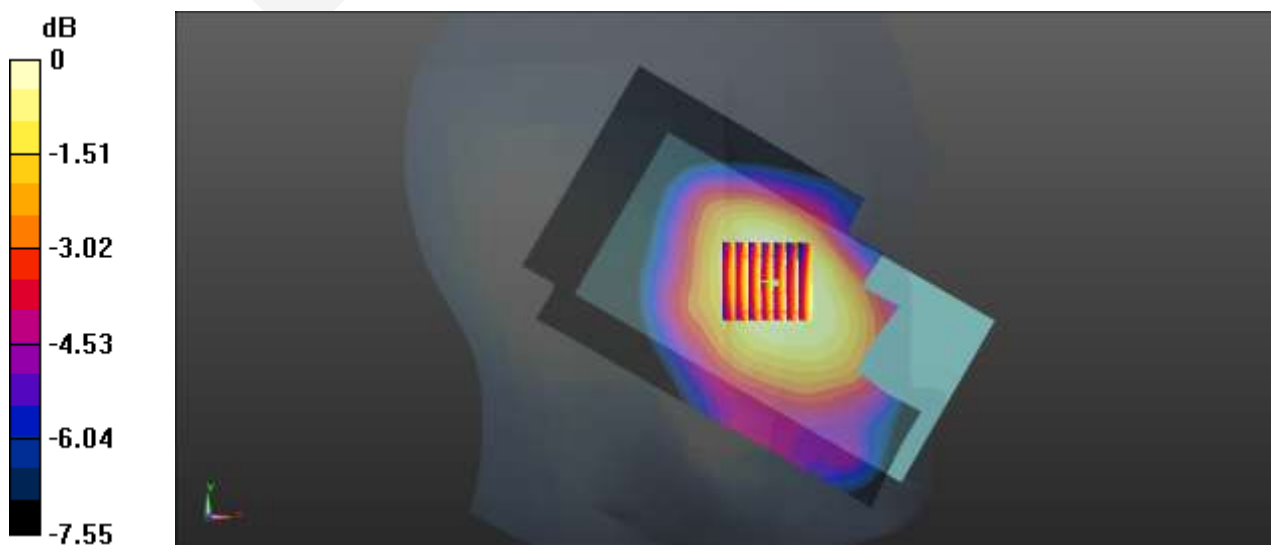

0 dB = 0.0890 W/kg = -10.51 dBW/kg

Test Laboratory: Bay Area Compliance Labs Corp.(Dongguan)

Test Plot 2#:GPRS 850 Back High Channel

DUT: Gravity 5; Type: Gravity 5

Communication System:Generic GPRS-4 SLOTS; Frequency: 848.8 MHz;Duty Cycle: 1:2

Medium parameters used: $f = 848.8 \text{ MHz}$; $\sigma = 0.986 \text{ S/m}$; $\epsilon_r = 55.024$; $\rho = 1000 \text{ kg/m}^3$

Phantom section: Flat Section

DASY5 Configuration:

- Probe: EX3DV4 - SN7329; ConvF(9.17, 9.17, 9.17); Calibrated: 2015/2/5;
- Sensor-Surface: 4mm (Mechanical Surface Detection)
- Electronics: DAE4 Sn1459; Calibrated: 2015/1/26
- Phantom: SAM (30deg probe tilt) with CRP v5.0_20150321; Type: QD000P40CD; Serial: TP:1874
- Measurement SW: DASY52, Version 52.8 (8);

Body/GSM 850 Back/Area Scan (61x111x1): Interpolated grid: $dx=1.500 \text{ mm}$, $dy=1.500 \text{ mm}$

Maximum value of SAR (interpolated) = 0.519 W/kg

Body/GSM 850 Back/Zoom Scan (7x7x7)/Cube 0: Measurement grid: $dx=5\text{mm}$, $dy=5\text{mm}$, $dz=5\text{mm}$

Reference Value = 22.52 V/m; Power Drift = -0.09 dB

Peak SAR (extrapolated) = 0.637 W/kg

SAR(1 g) = 0.486 W/kg; SAR(10 g) = 0.360 W/kg

Maximum value of SAR (measured) = 0.518 W/kg

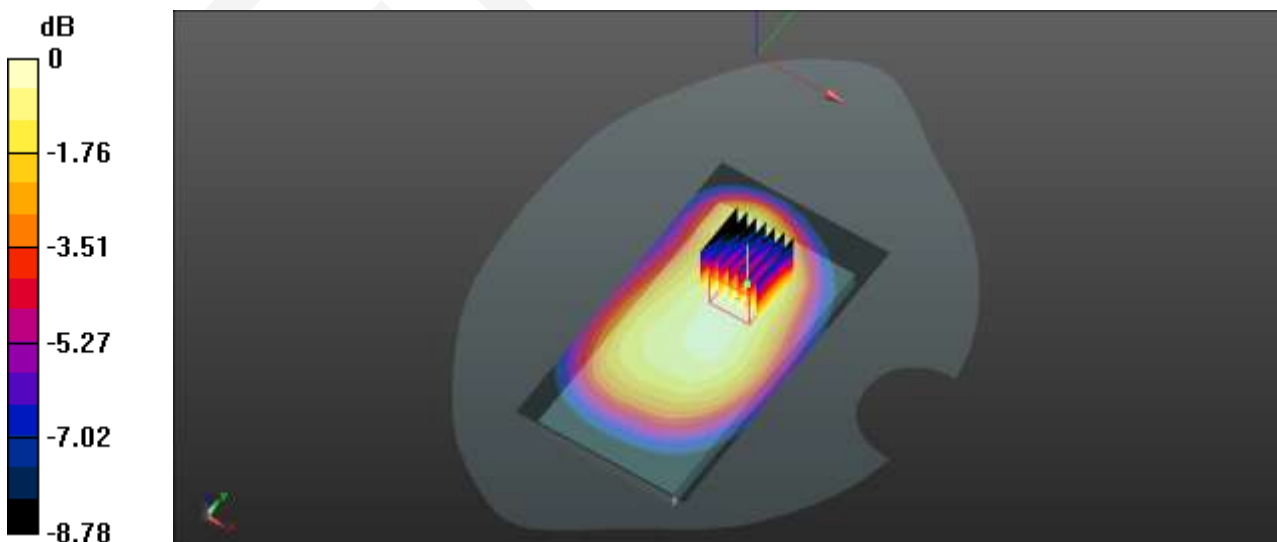

0 dB = 0.518 W/kg = -2.86 dBW/kg

Test Laboratory: Bay Area Compliance Labs Corp.(Dongguan)

Test Plot 3#:PCS 1900 Right Cheek High Channel

DUT: Gravity 5; Type: Gravity 5

Communication System: Generic GSM; Frequency: 1909.8 MHz; Duty Cycle: 1: 8

Medium parameters used: $f = 1909.8$ MHz; $\sigma = 1.416$ S/m; $\epsilon_r = 39.615$; $\rho = 1000$ kg/m³

Phantom section: Right Section

DASY5 Configuration:

- Probe: EX3DV4 - SN7329; ConvF(7.88, 7.88, 7.88); Calibrated: 2015/2/5;
- Sensor-Surface: 4mm (Mechanical Surface Detection)
- Electronics: DAE4 Sn1459; Calibrated: 2015/1/26
- Phantom: SAM (30deg probe tilt) with CRP v5.0_20150321; Type: QD000P40CD; Serial: TP:1874
- Measurement SW: DASY52, Version 52.8 (8);

Head/PCS 1900 Right Cheek/Area Scan (71x111x1): Interpolated grid: dx=1.500 mm, dy=1.500 mm

Maximum value of SAR (interpolated) = 0.143 W/kg

Head/PCS 1900 Right Cheek/Zoom Scan (7x7x7)/Cube 0: Measurement grid: dx=5mm, dy=5mm, dz=5mm

Reference Value = 4.139 V/m; Power Drift = 0.13 dB

Peak SAR (extrapolated) = 0.211 W/kg

SAR(1 g) = 0.130 W/kg; SAR(10 g) = 0.078 W/kg

Maximum value of SAR (measured) = 0.143 W/kg

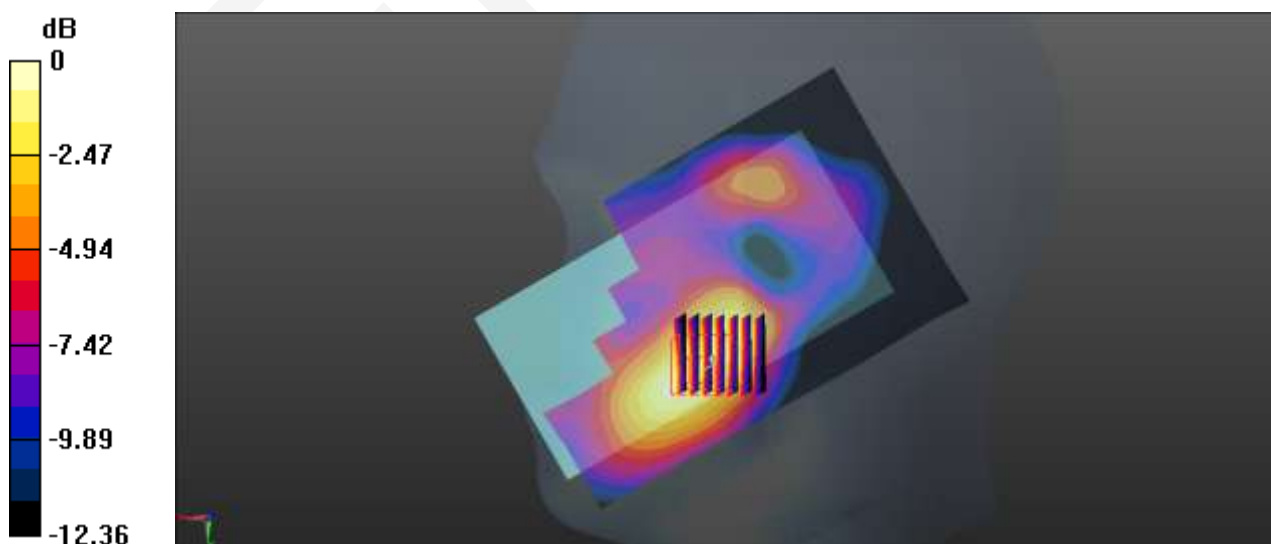

0 dB = 0.143 W/kg = -8.45 dBW/kg

Test Laboratory: Bay Area Compliance Labs Corp.(Dongguan)

Test Plot 4#:PCS 1900 Back Middle Channel

DUT: Gravity 5; Type: Gravity 5

Communication System: GPRS-3 SLOTS; Frequency: 1880 MHz; Duty Cycle: 1:2.667

Medium parameters used: $f = 1880 \text{ MHz}$; $\sigma = 1.542 \text{ S/m}$; $\epsilon_r = 53.718$; $\rho = 1000 \text{ kg/m}^3$

Phantom section: Flat Section

DASY5 Configuration:

- Probe: EX3DV4 - SN7329; ConvF(7.56, 7.56, 7.56); Calibrated: 2015/2/5;
- Sensor-Surface: 4mm (Mechanical Surface Detection)
- Electronics: DAE4 Sn1459; Calibrated: 2015/1/26
- Phantom: SAM (30deg probe tilt) with CRP v5.0_20150321; Type: QD000P40CD; Serial: TP:1874
- Measurement SW: DASY52, Version 52.8 (8);

Body/PCS 1900 Back/Area Scan (61x111x1): Interpolated grid: dx=1.500 mm, dy=1.500 mm

Maximum value of SAR (interpolated) = 0.954 W/kg

Body/PCS 1900 Back/Zoom Scan (7x7x7)/Cube 0: Measurement grid: dx=5mm, dy=5mm, dz=5mm

Reference Value = 12.08 V/m; Power Drift = -0.18 dB

Peak SAR (extrapolated) = 1.64 W/kg

SAR(1 g) = 0.922 W/kg; SAR(10 g) = 0.478 W/kg

Maximum value of SAR (measured) = 1.04 W/kg

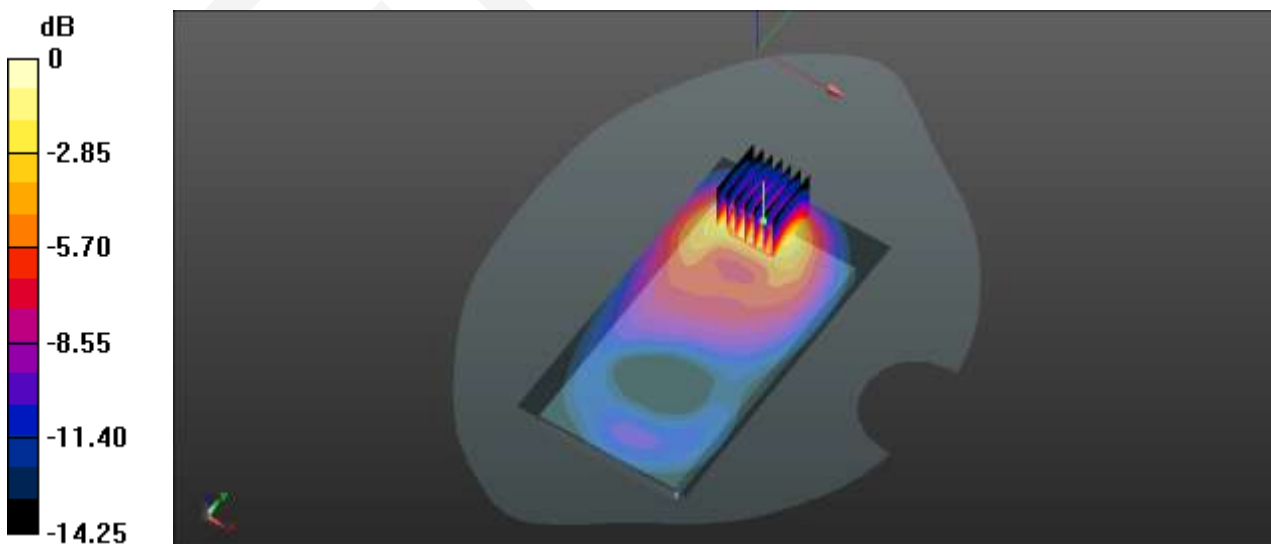

0 dB = 1.04 W/kg = 0.17 dBW/kg

Test Laboratory: Bay Area Compliance Labs Corp.(Dongguan)

Test Plot 5#:WCDMA 850 Left Cheek Low Channel

DUT: Gravity 5; Type: Gravity 5

Communication System:BAND V; Frequency: 826.4 MHz;Duty Cycle: 1:1

Medium parameters used: f = 826.4 MHz; $\sigma = 0.879$ S/m; $\epsilon_r = 42.868$; $\rho = 1000$ kg/m³

Phantom section: Left Section

DASY5 Configuration:

- Probe: EX3DV4 - SN7329; ConvF(9.52, 9.52, 9.52); Calibrated: 2015/2/5;
- Sensor-Surface: 4mm (Mechanical Surface Detection)
- Electronics: DAE4 Sn1459; Calibrated: 2015/1/26
- Phantom: SAM (30deg probe tilt) with CRP v5.0_20150321; Type: QD000P40CD; Serial: TP:1874
- Measurement SW: DASY52, Version 52.8 (8);

Head/WCDMA 850 Left Cheek/Area Scan (71x111x1): Interpolated grid: dx=1.500 mm, dy=1.500 mm

Maximum value of SAR (interpolated) = 0.0716 W/kg

Head/WCDMA 850 Left Cheek/Zoom Scan (7x7x7)/Cube 0: Measurement grid: dx=5mm, dy=5mm, dz=5mm

Reference Value = 3.002 V/m; Power Drift = 0.01 dB

Peak SAR (extrapolated) = 0.0840 W/kg

SAR(1 g) = 0.068 W/kg; SAR(10 g) = 0.054 W/kg

Maximum value of SAR (measured) = 0.0713 W/kg

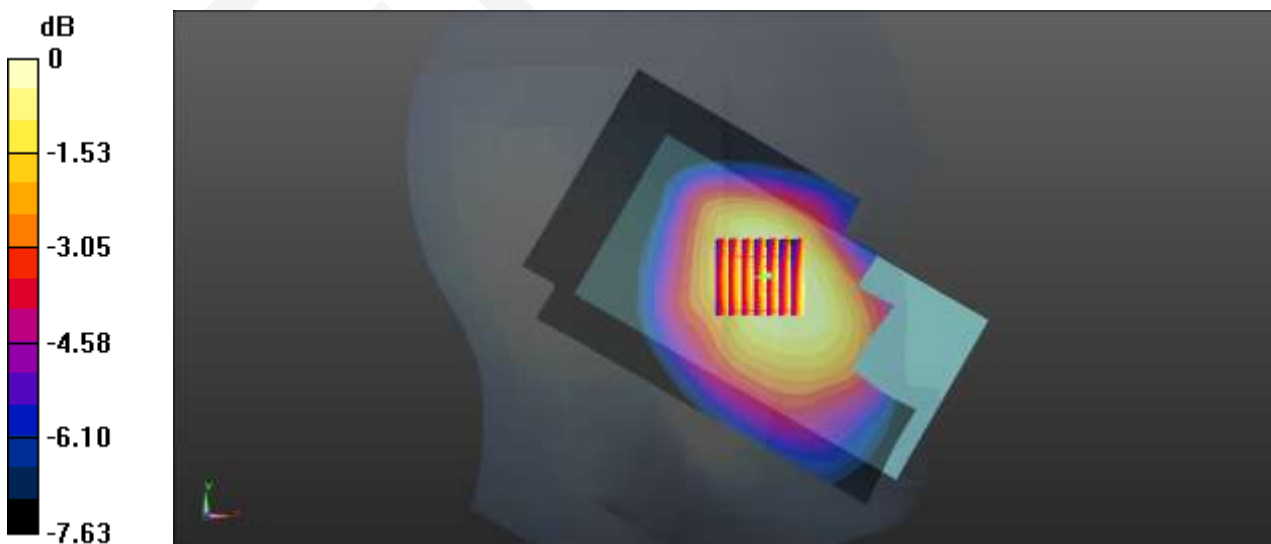

0 dB = 0.0713 W/kg = -11.47 dBW/kg

Test Laboratory: Bay Area Compliance Labs Corp.(Dongguan)

Test Plot 6#:WCDMA 850 Back Low Channel

DUT: Gravity 5; Type: Gravity 5

Communication System: BAND V; Frequency: 826.4 MHz; Duty Cycle: 1:1

Medium parameters used: $f = 826.4 \text{ MHz}$; $\sigma = 0.966 \text{ S/m}$; $\epsilon_r = 55.163$; $\rho = 1000 \text{ kg/m}^3$

Phantom section: Flat Section

DASY5 Configuration:

- Probe: EX3DV4 - SN7329; ConvF(9.17, 9.17, 9.17); Calibrated: 2015/2/5;
- Sensor-Surface: 4mm (Mechanical Surface Detection)
- Electronics: DAE4 Sn1459; Calibrated: 2015/1/26
- Phantom: SAM (30deg probe tilt) with CRP v5.0_20150321; Type: QD000P40CD; Serial: TP:1874
- Measurement SW: DASY52, Version 52.8 (8);

Body/WCDMA 850 Back/Area Scan (61x111x1): Interpolated grid: $dx=1.500 \text{ mm}$, $dy=1.500 \text{ mm}$

Maximum value of SAR (interpolated) = 0.307 W/kg

Body/WCDMA 850 Back/Zoom Scan (7x7x7)/Cube 0: Measurement grid: $dx=5\text{mm}$, $dy=5\text{mm}$, $dz=5\text{mm}$

Reference Value = 17.51 V/m; Power Drift = -0.12 dB

Peak SAR (extrapolated) = 0.384 W/kg

SAR(1 g) = 0.295 W/kg; SAR(10 g) = 0.218 W/kg

Maximum value of SAR (measured) = 0.310 W/kg

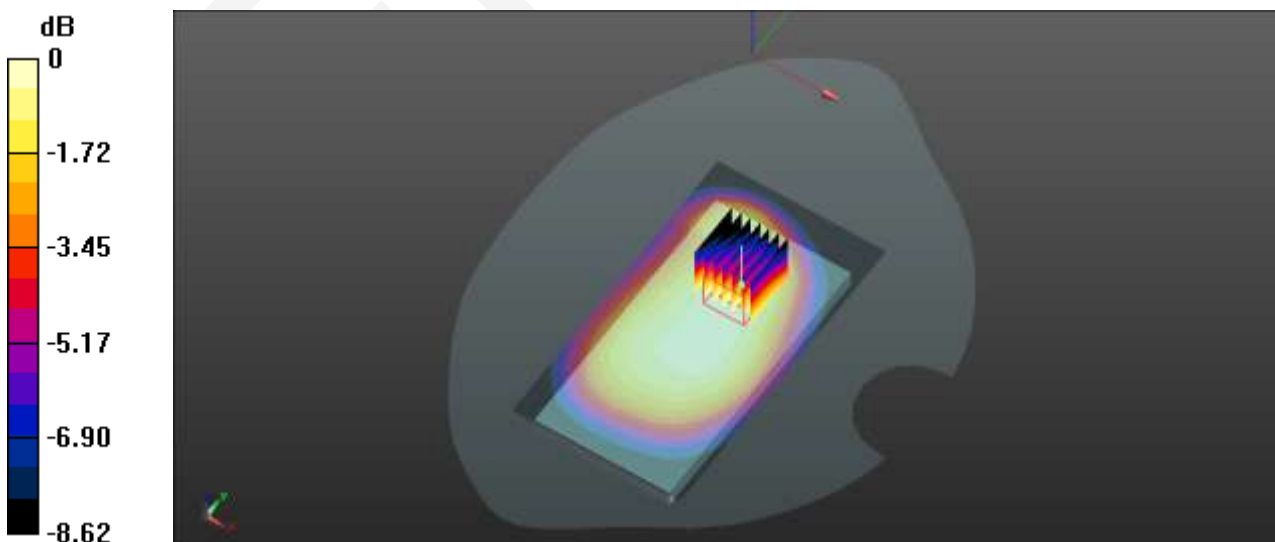

0 dB = 0.310 W/kg = -5.09 dBW/kg

Test Laboratory: Bay Area Compliance Labs Corp.(Dongguan)

Test Plot 7#:WCDMA 1900 Right Cheek High Channel

DUT: Gravity 5; Type: Gravity 5

Communication System:BAND II; Frequency: 1907.6 MHz;Duty Cycle: 1:1

Medium parameters used: $f = 1907.6 \text{ MHz}$; $\sigma = 1.413 \text{ S/m}$; $\epsilon_r = 39.561$; $\rho = 1000 \text{ kg/m}^3$

Phantom section: Right Section

DASY5 Configuration:

- Probe: EX3DV4 - SN7329; ConvF(7.88, 7.88, 7.88); Calibrated: 2015/2/5;
- Sensor-Surface: 4mm (Mechanical Surface Detection)
- Electronics: DAE4 Sn1459; Calibrated: 2015/1/26
- Phantom: SAM (30deg probe tilt) with CRP v5.0_20150321; Type: QD000P40CD; Serial: TP:1874
- Measurement SW: DASY52, Version 52.8 (8);

Head/WCDMA 1900 Right Cheek/Area Scan (71x111x1): Interpolated grid: $dx=1.500 \text{ mm}$, $dy=1.500 \text{ mm}$

Maximum value of SAR (interpolated) = 0.259 W/kg

Head/WCDMA 1900 Right Cheek/Zoom Scan (7x7x7)/Cube 0: Measurement grid: $dx=5\text{mm}$, $dy=5\text{mm}$, $dz=5\text{mm}$

Reference Value = 5.600 V/m; Power Drift = -0.15 dB

Peak SAR (extrapolated) = 0.385 W/kg

SAR(1 g) = 0.237 W/kg; SAR(10 g) = 0.142 W/kg

Maximum value of SAR (measured) = 0.259 W/kg

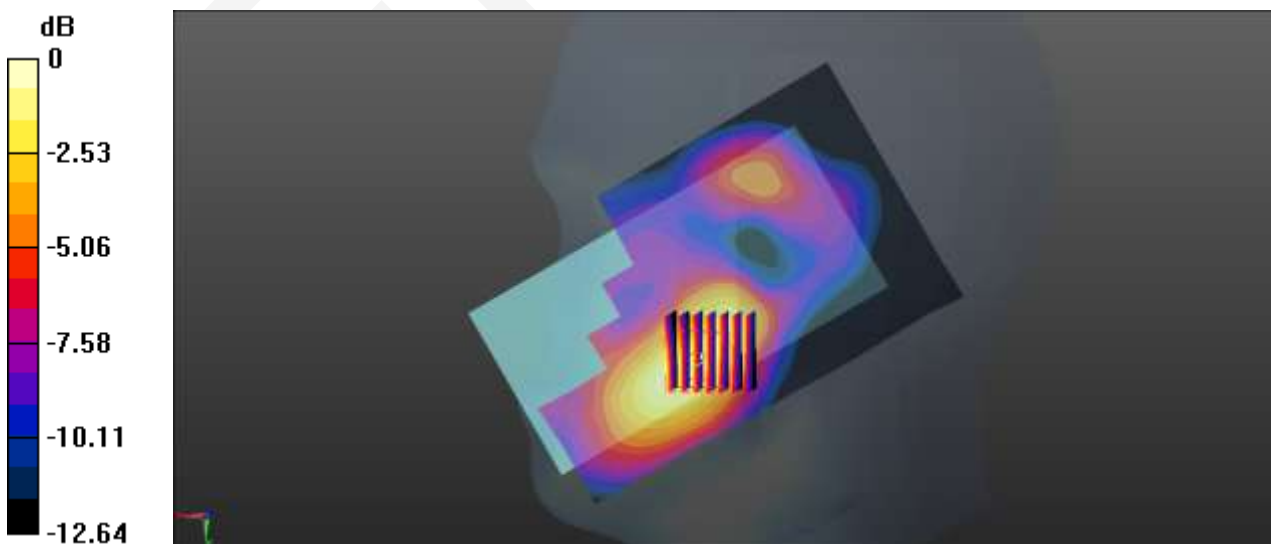

0 dB = 0.259 W/kg = -5.87 dBW/kg

Test Laboratory: Bay Area Compliance Labs Corp.(Dongguan)

Test Plot 8#: WCDMA 1900 Back High Channel

DUT: Gravity 5; Type: Gravity 5

Communication System: BAND II; Frequency: 1907.6 MHz; Duty Cycle: 1:1

Medium parameters used: $f = 1907.6 \text{ MHz}$; $\sigma = 1.491 \text{ S/m}$; $\epsilon_r = 53.59$; $\rho = 1000 \text{ kg/m}^3$

Phantom section: Flat Section

DASY5 Configuration:

- Probe: EX3DV4 - SN7329; ConvF(7.56, 7.56, 7.56); Calibrated: 2015/2/5;
- Sensor-Surface: 4mm (Mechanical Surface Detection)
- Electronics: DAE4 Sn1459; Calibrated: 2015/1/26
- Phantom: SAM (30deg probe tilt) with CRP v5.0_20150321; Type: QD000P40CD; Serial: TP:1874
- Measurement SW: DASY52, Version 52.8 (8);

Body/WCDMA 1900 Back/Area Scan (61x111x1): Interpolated grid: $dx=1.500 \text{ mm}$, $dy=1.500 \text{ mm}$

Maximum value of SAR (interpolated) = 1.01 W/kg

Body/WCDMA 1900 Back/Zoom Scan (7x7x7)/Cube 0: Measurement grid: $dx=5\text{mm}$, $dy=5\text{mm}$, $dz=5\text{mm}$

Reference Value = 12.12 V/m; Power Drift = -0.01 dB

Peak SAR (extrapolated) = 1.72 W/kg

SAR(1 g) = 0.975 W/kg; SAR(10 g) = 0.505 W/kg

Maximum value of SAR (measured) = 1.09 W/kg

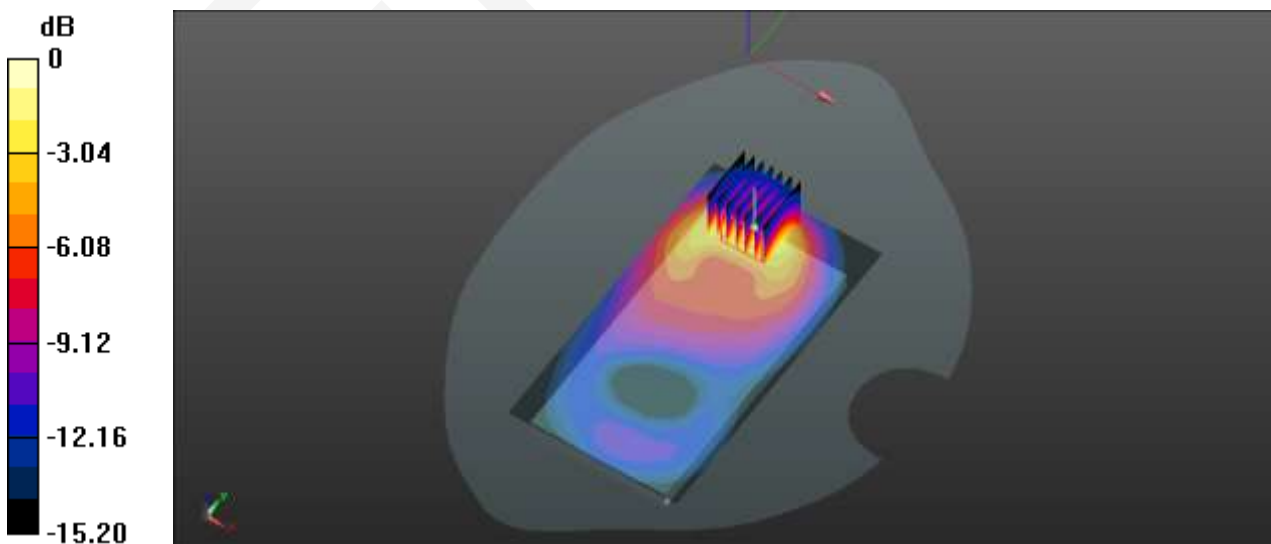

0 dB = 1.09 W/kg = 0.37 dBW/kg

APPENDIX A MEASUREMENT UNCERTAINTY

The uncertainty budget has been determined for the measurement system and is given in the following Table.

Measurement uncertainty evaluation for IEEE1528-2013 SAR test

Source of uncertainty	Tolerance/uncertainty ± %	Probability distribution	Disisor	ci (1 g)	ci (10 g)	Standard uncertainty ± %, (1 g)	Standard uncertainty ± %, (10 g)
Measurement system							
Probe calibration	6.55	N	1	1	1	6.6	6.6
Axial Isotropy	4.7	R	√3	1	1	2.7	2.7
Hemispherical Isotropy	9.6	R	√3	0	0	0.0	0.0
Boundary effect	1.0	R	√3	1	1	0.6	0.6
Linearity	4.7	R	√3	1	1	2.7	2.7
Detection limits	1.0	R	√3	1	1	0.6	0.6
Readout electronics	0.3	N	1	1	1	0.3	0.3
Response time	0.0	R	√3	1	1	0.0	0.0
Integration time	0.0	R	√3	1	1	0.0	0.0
RF ambientconditions – noise	1.0	R	√3	1	1	0.6	0.6
RF ambient conditions–reflections	1.0	R	√3	1	1	0.6	0.6
Probe positioner mech. Restrictions	0.8	R	√3	1	1	0.5	0.5
Probe positioning with respect to phantom shell	6.7	R	√3	1	1	3.9	3.9
Post-processing	2.0	R	√3	1	1	1.2	1.2
Test sample related							
Test sample positioning	2.8	N	1	1	1	2.8	2.8
Device holder uncertainty	6.3	N	1	1	1	6.3	6.3
Drift of output power	5.0	R	√3	1	1	2.9	2.9
Phantom and set-up							
Phantom uncertainty (shape and thickness tolerances)	4.0	R	√3	1	1	2.3	2.3
Liquid conductivity target)	5.0	R	√3	0.64	0.43	1.8	1.2
Liquid conductivity meas.)	2.5	N	1	0.64	0.43	1.6	1.1
Liquid permittivity target)	5.0	R	√3	0.6	0.49	1.7	1.4
Liquid permittivity meas.)	2.5	N	1	0.6	0.49	1.5	1.2
Combined standard uncertainty		RSS				12.2	12.0
Expanded uncertainty 95 % confidence interval)						24.3	23.9

Measurement uncertainty evaluation for IEC62209-2 SAR test

Source of uncertainty	Tolerance/uncertainty ± %	Probability distribution	Disisor	ci (1 g)	ci (10 g)	Standard uncertainty ± %, (1 g)	Standard uncertainty ± %, (10 g)
Measurement system							
Probe calibration	6.55	N	1	1	1	6.6	6.6
Axial Isotropy	4.7	R	√3	1	1	2.7	2.7
Hemispherical Isotropy	9.6	R	√3	0	0	0.0	0.0
Linearity	4.7	R	√3	1	1	2.7	2.7
Modulation Response	0.0	R	√3	1	1	0.0	0.0
Detection limits	1.0	R	√3	1	1	0.6	0.6
Boundary effect	1.0	R	√3	1	1	0.6	0.6
Readout electronics	0.3	N	1	1	1	0.3	0.3
Response time	0.0	R	√3	1	1	0.0	0.0
Integration time	0.0	R	√3	1	1	0.0	0.0
RF ambient conditions – noise	1.0	R	√3	1	1	0.6	0.6
RF ambient conditions–reflections	1.0	R	√3	1	1	0.6	0.6
Probe positioner mech. Restrictions	0.8	R	√3	1	1	0.5	0.5
Probe positioning with respect to phantom shell	6.7	R	√3	1	1	3.9	3.9
Post-processing	2.0	R	√3	1	1	1.2	1.2
Test sample related							
Device holder Uncertainty	6.3	N	1	1	1	6.3	6.3
Test sample positioning	2.8	N	1	1	1	2.8	2.8
Power scaling	4.5	R	√3	1	1	2.6	2.6
Drift of output power	5.0	R	√3	1	1	2.9	2.9
Phantom and set-up							
Phantom uncertainty (shape and thickness tolerances)	4.0	R	√3	1	1	2.3	2.3
Algorithm for correcting SAR for deviations in permittivity and conductivity	1.9	N	1	1	0.84	1.1	0.9
Liquid conductivity (meas.)	2.5	N	1	0.64	0.43	1.6	1.1
Liquid permittivity (meas.)	2.5	N	1	0.6	0.49	1.5	1.2
Temp. unc. - Conductivity	1.7	R	√3	0.78	0.71	0.8	0.7
Temp. unc. - Permittivity	0.3	R	√3	0.23	0.26	0.0	0.0
Combined standard uncertainty		RSS				12.2	12.1
Expanded uncertainty 95 % confidence interval)						24.5	24.2

APPENDIX B – PROBE CALIBRATION CERTIFICATES

**Calibration Laboratory of
Schmid & Partner
Engineering AG**
Zeughausstrasse 43, 8004 Zurich, Switzerland



S Schweizerischer Kalibrierdienst
C Service suisse d'étalonnage
S Servizio svizzero di taratura
S Swiss Calibration Service

Accredited by the Swiss Accreditation Service (SAS)
The Swiss Accreditation Service is one of the signatories to the EA
Multilateral Agreement for the recognition of calibration certificates

Accreditation No.: **SCS 0108**

Client **BACL China (Vitec)**

Certificate No: **EX3-7329_Feb15**

CALIBRATION CERTIFICATE

Object: **EX3DV4 - SN:7329**

Calibration procedure(s): **QA CAL-01.v9, QA CAL-23.v5, QA CAL-25.v6
Calibration procedure for dosimetric E-field probes**

Calibration date: **February 5, 2015**

This calibration certificate documents the traceability to national standards, which realize the physical units of measurements (SI).
The measurements and the uncertainties with confidence probability are given on the following pages and are part of the certificate.

All calibrations have been conducted in the closed laboratory facility: environment temperature (22 ± 3)°C and humidity < 70%.

Calibration Equipment used (M&TE critical for calibration)

Primary Standards	ID	Cal Date (Certificate No.)	Scheduled Calibration
Power meter E4419B	GB41293874	03-Apr-14 (No. 217-01911)	Apr-15
Power sensor E4412A	MY41498087	03-Apr-14 (No. 217-01911)	Apr-15
Reference 3 dB Attenuator	SN: S5054 (3c)	03-Apr-14 (No. 217-01915)	Apr-15
Reference 20 dB Attenuator	SN: S6277 (20x)	03-Apr-14 (No. 217-01919)	Apr-15
Reference 30 dB Attenuator	SN: S5129 (30b)	03-Apr-14 (No. 217-01920)	Apr-15
Reference Probe ES3DV2	SN: 3013	30-Dec-14 (No. ES3-3013_Dec14)	Dec-15
DAE4	SN: 660	14-Jan-15 (No. DAE4-660_Jan15)	Jan-16
Secondary Standards	ID	Check Date (in house)	Scheduled Check
RF generator HP 8648C	US3642UD1700	4-Aug-09 (in house check Apr-13)	In house check: Apr-16
Network Analyzer HP 8753E	US37390585	18-Oct-01 (in house check Oct-14)	In house check: Oct-15

Calibrated by:	Name Claudio Leubler	Function Laboratory Technician	Signature
Approved by:	Name Katja Pokovic	Function Technical Manager	Signature

Issued: February 9, 2015

This calibration certificate shall not be reproduced except in full without written approval of the laboratory.

**Calibration Laboratory of
Schmid & Partner
Engineering AG**
Zeughausstrasse 43, 8004 Zurich, Switzerland



S Schweizerischer Kalibrierdienst
C Service suisse d'étalonnage
S Servizio svizzero di taratura
S Swiss Calibration Service

Accredited by the Swiss Accreditation Service (SAS)
The Swiss Accreditation Service is one of the signatories to the EA
Multilateral Agreement for the recognition of calibration certificates

Accreditation No.: **SCS 0108**

Glossary:

TSL	tissue simulating liquid
NORM _{x,y,z}	sensitivity in free space
ConvF	sensitivity in TSL / NORM _{x,y,z}
DCP	diode compression point
CF	crest factor (1/duty_cycle) of the RF signal
A, B, C, D	modulation dependent linearization parameters
Polarization φ	φ rotation around probe axis
Polarization θ	θ rotation around an axis that is in the plane normal to probe axis (at measurement center), i.e., θ = 0 is normal to probe axis
Connector Angle	information used in DASY system to align probe sensor X to the robot coordinate system

Calibration is Performed According to the Following Standards:

- a) IEEE Std 1528-2013, "IEEE Recommended Practice for Determining the Peak Spatial-Averaged Specific Absorption Rate (SAR) in the Human Head from Wireless Communications Devices: Measurement Techniques", June 2013
- b) IEC 62209-1, "Procedure to measure the Specific Absorption Rate (SAR) for hand-held devices used in close proximity to the ear (frequency range of 300 MHz to 3 GHz)", February 2005

Methods Applied and Interpretation of Parameters:

- **NORM_{x,y,z}**: Assessed for E-field polarization θ = 0 (f ≤ 900 MHz in TEM-cell; f > 1800 MHz: R22 waveguide). NORM_{x,y,z} are only intermediate values, i.e., the uncertainties of NORM_{x,y,z} does not affect the E²-field uncertainty inside TSL (see below ConvF).
- **NORM(f)_{x,y,z} = NORM_{x,y,z} * frequency_response** (see Frequency Response Chart). This linearization is implemented in DASY4 software versions later than 4.2. The uncertainty of the frequency response is included in the stated uncertainty of ConvF.
- **DCP_{x,y,z}**: DCP are numerical linearization parameters assessed based on the data of power sweep with CW signal (no uncertainty required). DCP does not depend on frequency nor media.
- **PAR**: PAR is the Peak to Average Ratio that is not calibrated but determined based on the signal characteristics
- **A_{x,y,z}; B_{x,y,z}; C_{x,y,z}; D_{x,y,z}; VR_{x,y,z}; A, B, C, D** are numerical linearization parameters assessed based on the data of power sweep for specific modulation signal. The parameters do not depend on frequency nor media. VR is the maximum calibration range expressed in RMS voltage across the diode.
- **ConvF and Boundary Effect Parameters**: Assessed in flat phantom using E-field (or Temperature Transfer Standard for f ≤ 800 MHz) and inside waveguide using analytical field distributions based on power measurements for f > 800 MHz. The same setups are used for assessment of the parameters applied for boundary compensation (alpha, depth) of which typical uncertainty values are given. These parameters are used in DASY4 software to improve probe accuracy close to the boundary. The sensitivity in TSL corresponds to NORM_{x,y,z} * ConvF whereby the uncertainty corresponds to that given for ConvF. A frequency dependent ConvF is used in DASY version 4.4 and higher which allows extending the validity from ± 50 MHz to ± 100 MHz.
- **Spherical isotropy (3D deviation from isotropy)**: in a field of low gradients realized using a flat phantom exposed by a patch antenna.
- **Sensor Offset**: The sensor offset corresponds to the offset of virtual measurement center from the probe tip (on probe axis). No tolerance required.
- **Connector Angle**: The angle is assessed using the information gained by determining the NORM_x (no uncertainty required).

EX3DV4 – SN:7329

February 5, 2015

Probe EX3DV4

SN:7329

Manufactured: December 11, 2014
Calibrated: February 5, 2015

Calibrated for DASY/EASY Systems
(Note: non-compatible with DASY2 system!)

EX3DV4- SN:7329

February 5, 2015

DASY/EASY - Parameters of Probe: EX3DV4 - SN:7329

Basic Calibration Parameters

	Sensor X	Sensor Y	Sensor Z	Unc (k=2)
Norm ($\mu\text{V}/(\text{V}/\text{m})^2$) ^A	0.48	0.43	0.46	± 10.1 %
DCP (mV) ^B	96.7	97.6	94.2	

Modulation Calibration Parameters

UID	Communication System Name		A dB	B dB $\sqrt{\mu\text{V}}$	C	D dB	VR mV	Unc ^E (k=2)
0	CW	X	0.0	0.0	1.0	0.00	137.9	±3.0 %
		Y	0.0	0.0	1.0		147.0	
		Z	0.0	0.0	1.0		150.5	

The reported uncertainty of measurement is stated as the standard uncertainty of measurement multiplied by the coverage factor k=2, which for a normal distribution corresponds to a coverage probability of approximately 95%.

^A The uncertainties of NormX,Y,Z do not affect the E²-field uncertainty inside TSL (see Pages 5 and 6).

^B Numerical linearization parameter; uncertainty not required.

^E Uncertainty is determined using the max. deviation from linear response applying rectangular distribution and is expressed for the square of the field value.

EX3DV4- SN:7329

February 5, 2015

DASY/EASY - Parameters of Probe: EX3DV4 - SN:7329

Calibration Parameter Determined in Head Tissue Simulating Media

f (MHz) ^c	Relative Permittivity ^f	Conductivity (S/m) ^f	ConvF X	ConvF Y	ConvF Z	Alpha ^g	Depth ^d (mm)	Unct. (k=2)
900	41.5	0.97	9.52	9.52	9.52	0.40	0.86	± 12.0 %
1750	40.1	1.37	8.12	8.12	8.12	0.29	0.90	± 12.0 %
1900	40.0	1.40	7.88	7.88	7.88	0.68	0.61	± 12.0 %
2450	39.2	1.80	7.06	7.06	7.06	0.33	0.84	± 12.0 %

^c Frequency validity above 300 MHz of ± 100 MHz only applies for DASY v4.4 and higher (see Page 2), else it is restricted to ± 50 MHz. The uncertainty is the RSS of the ConvF uncertainty at calibration frequency and the uncertainty for the indicated frequency band. Frequency validity below 300 MHz is ± 10, 25, 40, 50 and 70 MHz for ConvF assessments at 30, 64, 128, 150 and 220 MHz respectively. Above 5 GHz frequency validity can be extended to ± 110 MHz.

^f At frequencies below 3 GHz, the validity of tissue parameters (c and σ) can be relaxed to ± 10% if liquid compensation formula is applied to measured SAR values. At frequencies above 3 GHz, the validity of tissue parameters (c and σ) is restricted to ± 5%. The uncertainty is the RSS of the ConvF uncertainty for indicated target tissue parameters.

^g Alpha/Depth are determined during calibration. SPEAG warrants that the remaining deviation due to the boundary effect after compensation is always less than ± 1% for frequencies below 3 GHz and below ± 2% for frequencies between 3-6 GHz at any distance larger than half the probe tip diameter from the boundary.

EX3DV4- SN:7329

February 5, 2015

DASY/EASY - Parameters of Probe: EX3DV4 - SN:7329

Calibration Parameter Determined in Body Tissue Simulating Media

f (MHz) ^C	Relative Permittivity ^F	Conductivity (Sim) ^F	ConvF X	ConvF Y	ConvF Z	Alpha ^G	Depth (mm) ^G	Unct. (k=2)
900	55.0	1.05	9.17	9.17	9.17	0.41	0.90	± 12.0 %
1750	53.4	1.49	7.85	7.85	7.85	0.70	0.64	± 12.0 %
1900	53.3	1.52	7.56	7.56	7.56	0.56	0.70	± 12.0 %
2450	52.7	1.95	7.20	7.20	7.20	0.78	0.59	± 12.0 %

^C Frequency validity above 300 MHz of ± 100 MHz only applies for DASY v4.4 and higher (see Page 2), else it is restricted to ± 50 MHz. The uncertainty is the RSS of the ConvF uncertainty at calibration frequency and the uncertainty for the indicated frequency band. Frequency validity below 300 MHz is ± 10, 25, 40, 50 and 70 MHz for ConvF assessments at 30, 64, 128, 150 and 220 MHz respectively. Above 5 GHz frequency validity can be extended to ± 110 MHz.

^F At frequencies below 3 GHz, the validity of tissue parameters (ϵ and σ) can be relaxed to ± 10% if liquid compensation formula is applied to measured SAR values. At frequencies above 3 GHz, the validity of tissue parameters (ϵ and σ) is restricted to ± 5%. The uncertainty is the RSS of the ConvF uncertainty for indicated target tissue parameters.

^G Alpha/Depth are determined during calibration. SPEAG warrants that the remaining deviation due to the boundary effect after compensation is always less than ± 1% for frequencies below 3 GHz and below ± 2% for frequencies between 3-6 GHz at any distance larger than half the probe tip diameter from the boundary.

EX3DV4- SN:7329

February 5, 2015

Frequency Response of E-Field (TEM-Cell:ifi110 EXX, Waveguide: R22)

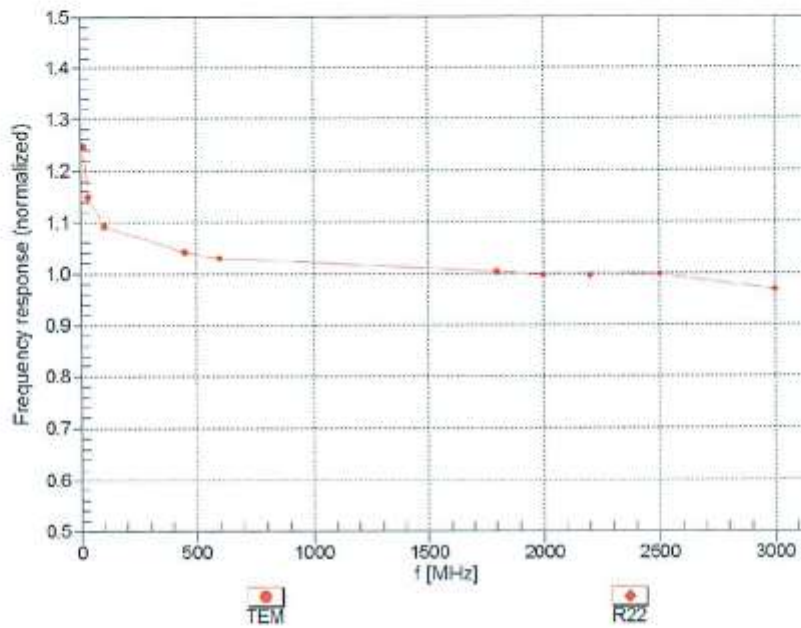

Uncertainty of Frequency Response of E-field: $\pm 6.3\%$ (k=2)

EX3DV4- SN:7329

February 5, 2015

Receiving Pattern (ϕ), $\theta = 0^\circ$

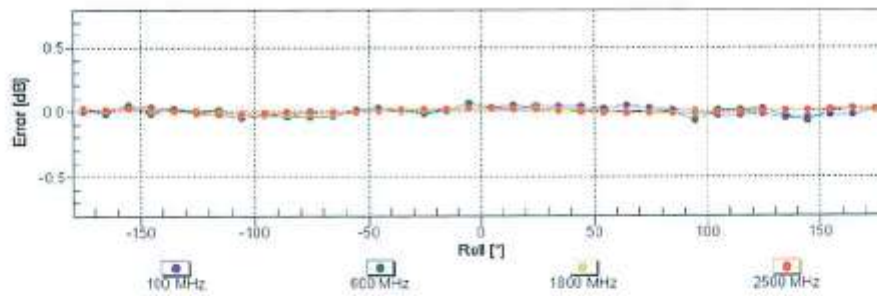
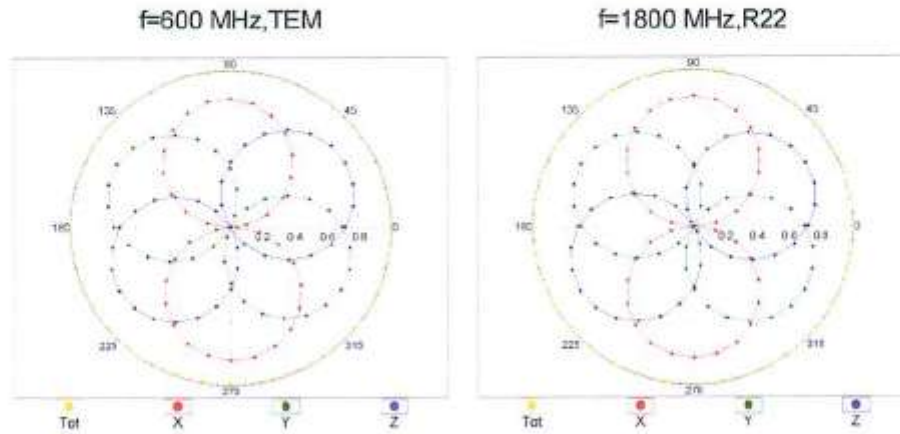

Uncertainty of Axial Isotropy Assessment: $\pm 0.5\%$ ($k=2$)

EX3DV4- SN:7329

February 5, 2015

Dynamic Range $f(SAR_{head})$ (TEM cell, $f_{eval} = 1900$ MHz)

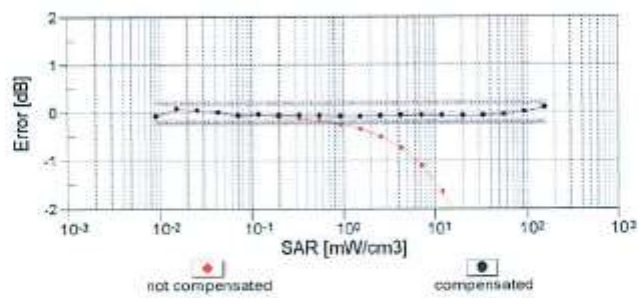
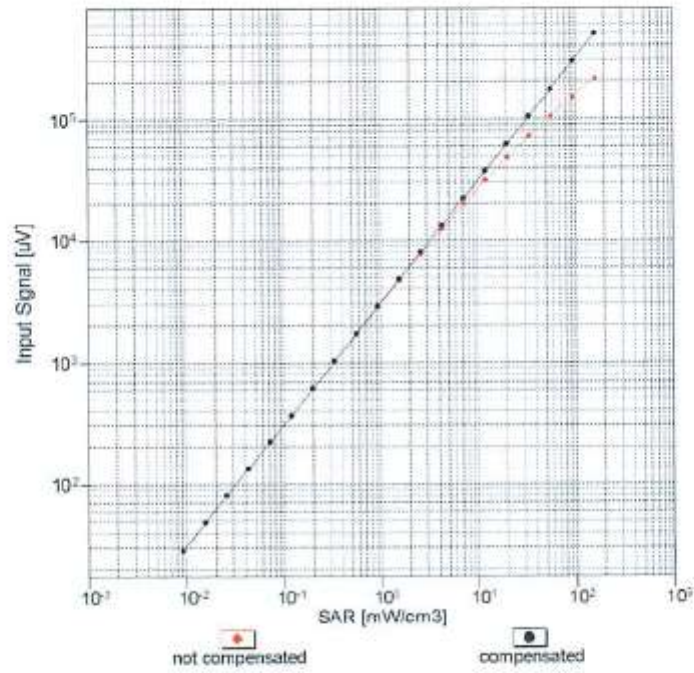

Uncertainty of Linearity Assessment: $\pm 0.6\%$ (k=2)

EX3DV4- SN:7329

February 5, 2015

Conversion Factor Assessment

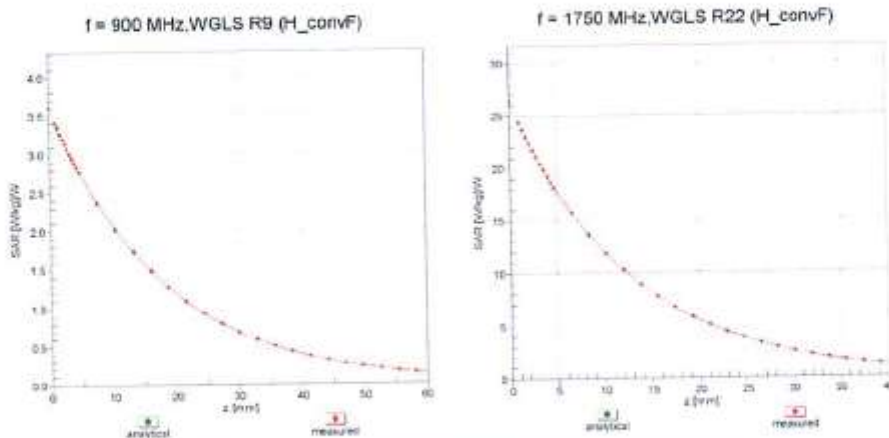

Deviation from Isotropy in Liquid Error (ϕ, θ), f = 900 MHz

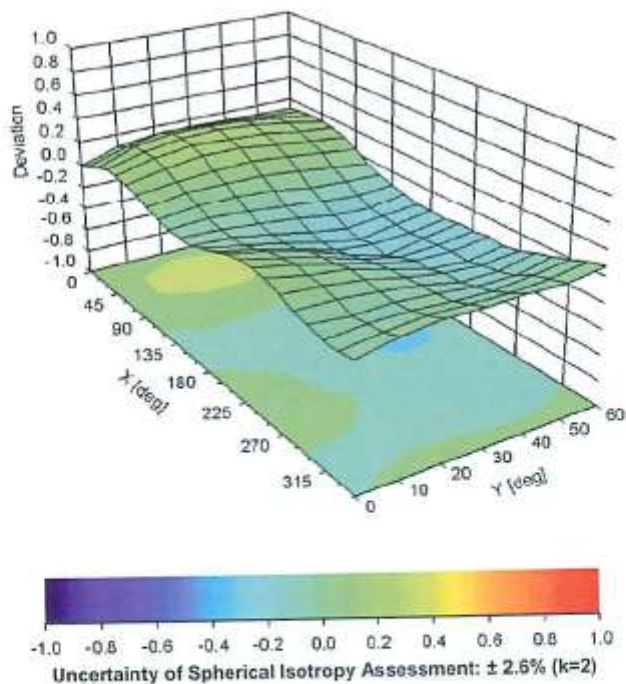

EX3DV4- SN:7329

February 5, 2015

DASY/EASY - Parameters of Probe: EX3DV4 - SN:7329

Other Probe Parameters

Sensor Arrangement	Triangular
Connector Angle (°)	24.5
Mechanical Surface Detection Mode	enabled
Optical Surface Detection Mode	disabled
Probe Overall Length	337 mm
Probe Body Diameter	10 mm
Tip Length	9 mm
Tip Diameter	2.5 mm
Probe Tip to Sensor X Calibration Point	1 mm
Probe Tip to Sensor Y Calibration Point	1 mm
Probe Tip to Sensor Z Calibration Point	1 mm
Recommended Measurement Distance from Surface	1.4 mm

APPENDIX C DIPOLE CALIBRATION CERTIFICATES

NCL CALIBRATION LABORATORIES

Calibration File No: DC-1599
Project Number: BAC-dipole-cal-5779

CERTIFICATE OF CALIBRATION

It is certified that the equipment identified below has been calibrated in the
NCL CALIBRATION LABORATORIES by qualified personnel following recognized
procedures and using transfer standards traceable to NRC/NIST.

Validation Dipole(Head and Body)

Manufacturer: APREL Laboratories

Part number: ALS-D-835-S-2

Frequency: 835 MHz

Serial No: 180-00558

Customer: Bay Area Compliance Laboratory (China)

Calibrated: 8th October 2014
Released on: 8th October 2014

This Calibration Certificate is incomplete Unless Accompanied with the Calibration Results Summary

Released By: _____



Art Brennan, Quality Manager

NCL CALIBRATION LABORATORIES

Suite 102, 303 Terry Fox Dr.
Kanata, ONTARIO
CANADA K2K 3J1

Division of APREL Lab.
TEL: (813) 435-8300
FAX: (613)405-8306

NCL Calibration Laboratories

Division of APREL Laboratories.

Conditions

Dipole 180-00558 was received with a damaged connection for a re-calibration.

Ambient Temperature of the Laboratory: 22 °C +/- 0.5°C

Temperature of the Tissue: 21 °C +/- 0.5°C

Attestation

The below named signatories have conducted the calibration and review of the data which is presented in this calibration report.

We the undersigned attest that to the best of our knowledge the calibration of this subject has been accurately conducted and that all information contained within the results pages have been reviewed for accuracy.



Art Brennan, Quality Manager



Maryna Nesterova Calibration Engineer

Primary Measurement Standards

Instrument	Serial Number	Cal due date
Tektronix USB Power Meter	11C940	May 14, 2015
Network Analyzer Anritsu 37347C	002106	Feb. 20, 2015

This page has been reviewed for content and attested to by signature within this document.

NCL Calibration Laboratories

Division of APREL Laboratories.

Calibration Results Summary

The following results relate the Calibrated Dipole and should be used as a quick reference for the user.

Mechanical Dimensions

Length: 162.2 mm
 Height: 89.4 mm

Electrical Specification

Tissue	Frequency	SWR:	Return Loss	Impedance
Head	835 MHz	1.066 U	-30.344 dB	49.001 Ω
Body	835 MHz	1.089 U	-28.118 dB	53.117 Ω

System Validation Results

Tissue	Frequency	1 Gram	10 Gram	Peak
Head	835 MHz	9.773	6.174	14.713
Body	835 MHz	9.736	6.297	14.513

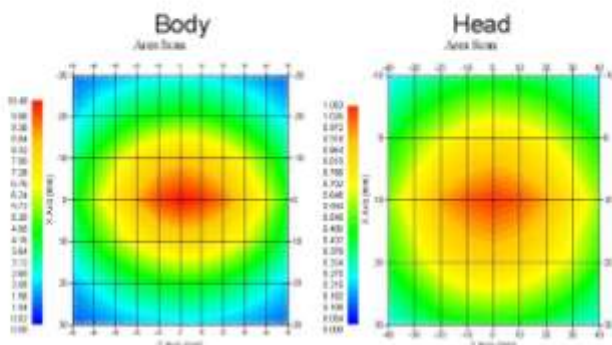

This page has been reviewed for content and attested to by signature within this document.

NCL Calibration Laboratories

Division of APREL Laboratories.

Introduction

This Calibration Report has been produced in line with the SSI Dipole Calibration Procedure SSI-TP-018-ALSAS. The results contained within this report are for Validation Dipole 180-00558. The calibration routine consisted of a three-step process. Step 1 was a mechanical verification of the dipole to ensure that it meets the mechanical specifications. Step 2 was an Electrical Calibration for the Validation Dipole, where the SWR, Impedance, and the Return loss were assessed. Step 3 involved a System Validation using the ALSAS-10U, along with APREL E-020 30 MHz to 6 GHz E-Field Probe Serial Number 225.

References

- IEC-62209 "Human exposure to radio frequency fields from hand-held and body-mounted wireless communication devices – Human models, instrumentation, and procedures"
- Part 2: "Procedure to determine the Specific Absorption Rate (SAR) for hand-held devices used in close proximity of the ear (frequency range of 30 MHz to 6 GHz)"
- TP-D01-032-E020-V2 E-Field probe calibration procedure
- D22-012-Tissue dielectric tissue calibration procedure
- D28-002-Dipole procedure for validation of SAR system using a dipole
- IEEE 1309 Draft Standard for Calibration of Electromagnetic Field Sensors and Probes, Excluding Antennas, from 9kHz to 40GHz

Conditions

Dipole 180-00558 was repaired prior to this calibration. The repair reliability depends upon correct usage of the dipole.

Ambient Temperature of the Laboratory: 22 °C +/- 0.5°C
Temperature of the Tissue: 20 °C +/- 0.5°C

Dipole Calibration uncertainty

The calibration uncertainty for the dipole is made up of various parameters presented below.

Mechanical	1%
Positioning Error	1.22%
Electrical	1.7%
Tissue	2.2%
Dipole Validation	2.2%
TOTAL	8.32% (16.64% K=2)

This page has been reviewed for content and attested to by signature within this document.

NCL Calibration Laboratories

Division of APREL Laboratories.

Dipole Calibration Results

Mechanical Verification

APREL Length	APREL Height	Measured Length	Measured Height
161.0 mm	89.8 mm	162.2 mm	89.4 mm

Electrical Verification

Tissue Type	Return Loss:	SWR:	Impedance:
Head	-30.344 dB	1.066 U	49.001Ω
Body	-28.118 dB	1.089 U	53.117 Ω □

Tissue Validation

	Dielectric constant, ϵ_r	Conductivity, σ [S/m]
Head Tissue 835MHz	43.42	0.94
Body Tissue 835MHz	55.77	1.01

This page has been reviewed for content and attested to by signature within this document.

NCL Calibration Laboratories

Division of APREL Laboratories.

The Following Graphs are the results as displayed on the Vector Network Analyzer.

S11 Parameter Return Loss

Head Tissue: Frequency Range 0.817 to 0.848 GHz

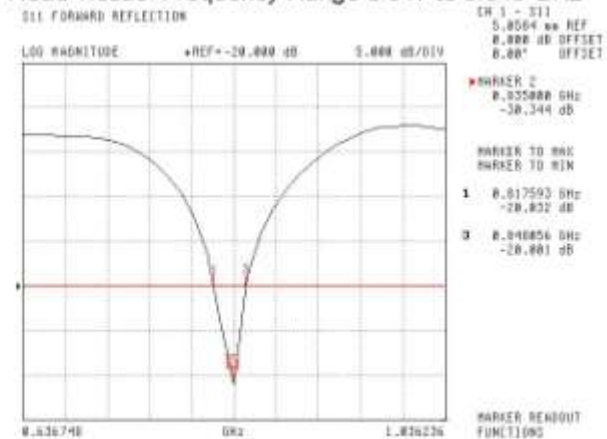

Body Tissue: Frequency Range 0.823 to 0.851 GHz

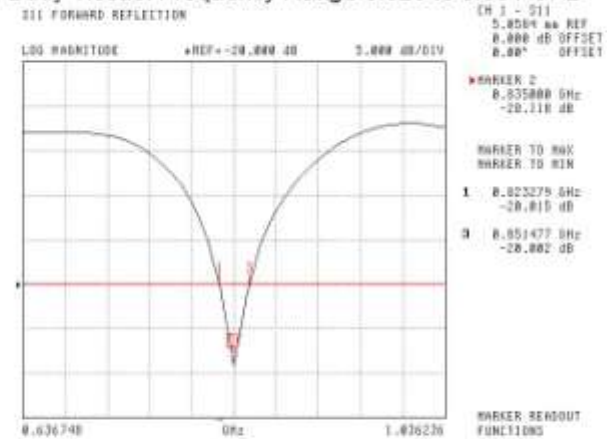

This page has been reviewed for content and attested to by signature within this document.

NCL Calibration Laboratories

Division of APREL Laboratories.

SWR

Head

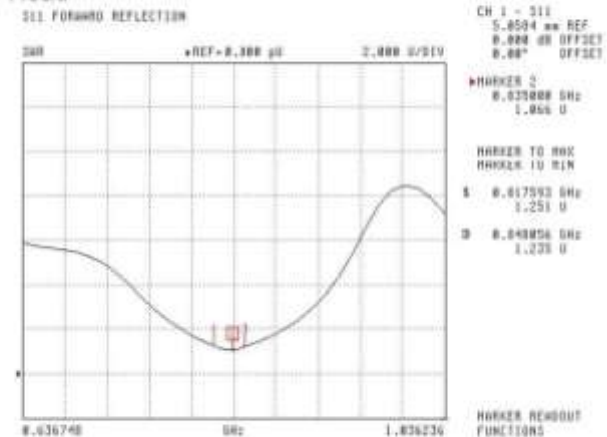

Body

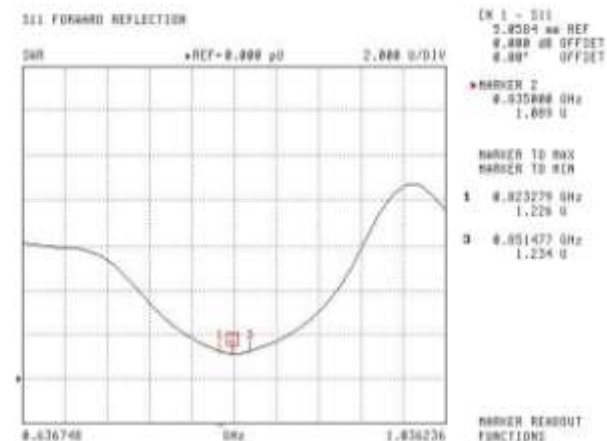

This page has been reviewed for content and attested to by signature within this document.

NCL Calibration Laboratories

Division of APREL Laboratories.

Smith Chart Dipole Impedance

Head

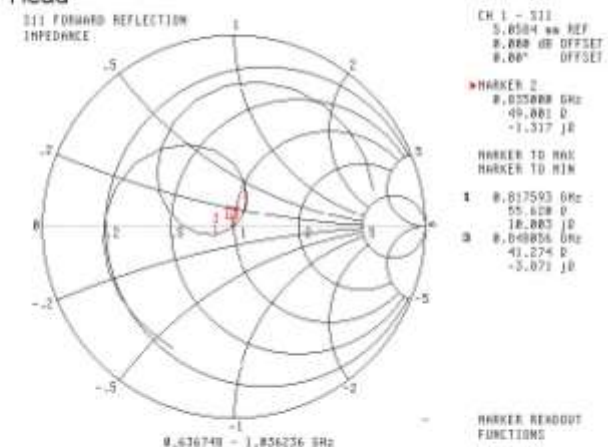

Body

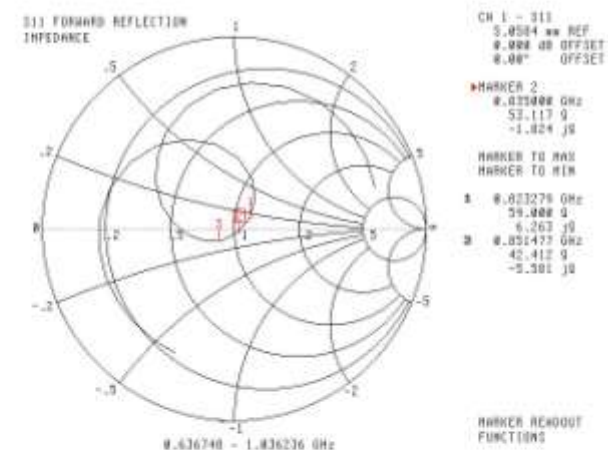

This page has been reviewed for content and attested to by signature within this document.

NCL Calibration Laboratories

Division of APREL Laboratories.

Test Equipment

The test equipment used during Probe Calibration, manufacturer, model number and, current calibration status are listed and located on the main APREL server R:\NCL\Calibration Equipment\Instrument List 2014.

This page has been reviewed for content and attested to by signature within this document.

9

NCL CALIBRATION LABORATORIES

Calibration File No: DC-1601
Project Number: BAC-dipole –cal-5779

CERTIFICATE OF CALIBRATION

It is certified that the equipment identified below has been calibrated in the
NCL CALIBRATION LABORATORIES by qualified personnel following recognized
procedures and using transfer standards traceable to NRC/NIST.

Validation Dipole (Head & Body)

Manufacturer: APREL Laboratories
Part number: ALS-D-1900-S-2
Frequency: 1900 MHz
Serial No: 210-00710

Customer: Bay Area Compliance Laboratory (China)

Calibrated: 9th October, 2014
Released on: 9th October, 2014

This Calibration Certificate is incomplete Unless Accompanied with the Calibration Results Summary

Released By: 
Art Brennan, Quality Manager

NCL CALIBRATION LABORATORIES
Suite 102, 303 Terry Fox Dr. Division of APREL Lab.
Kanata, ONTARIO TEL: (613) 435-8300
CANADA K2K 3J1 FAX: (613)435-8308

NCL Calibration Laboratories

Division of APREL Laboratories.

Conditions

Dipole 210-00710 was received in good condition and was a re-calibration.

Ambient Temperature of the Laboratory: 22 °C +/- 0.5°C

Temperature of the Tissue: 21 °C +/- 0.5°C

Attestation

The below named signatories have conducted the calibration and review of the data which is presented in this calibration report.

We the undersigned attest that to the best of our knowledge the calibration of this subject has been accurately conducted and that all information contained within the results pages have been reviewed for accuracy.



Art Brennan, Quality Manager



Maryna Nesterova Calibration Engineer

Primary Measurement Standards

Instrument	Serial Number	Cal due date
Tektronix USB Power Meter	11C940	May 14, 2015
Network Analyzer Anritsu 37347C	002106	Feb. 20, 2015

This page has been reviewed for content and attested to by signature within this document.

NCL Calibration Laboratories

Division of APREL Laboratories.

Calibration Results Summary

The following results relate the Calibrated Dipole and should be used as a quick reference for the user.

Mechanical Dimensions

Length: 67.1 mm
Height: 38.9 mm

Electrical Specification

Tissue	Frequency	SWR:	Return Loss	Impedance
Head	1900MHz	1.084 U	-27.92 dB	52.247 Ω
Body	1900MHz	1.128 U	-24.40 dB	52.618 Ω

System Validation Results

Tissue	Frequency	1 Gram	10 Gram	Peak
Head	1900 MHz	39.481	20.44	73.364
Body	1900 MHz	39.715	20.552	73.565

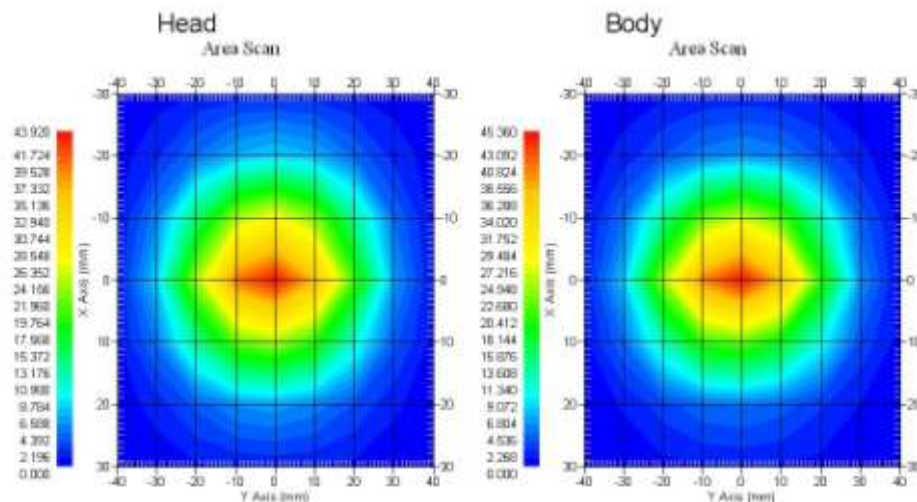

This page has been reviewed for content and attested to by signature within this document.

NCL Calibration Laboratories

Division of APREL Laboratories.

Introduction

This Calibration Report has been produced in line with the SSI Dipole Calibration Procedure SSI-TP-018-ALSAS. The results contained within this report are for Validation Dipole 210-00710. The calibration routine consisted of a three-step process. Step 1 was a mechanical verification of the dipole to ensure that it meets the mechanical specifications. Step 2 was an Electrical Calibration for the Validation Dipole, where the SWR, Impedance, and the Return loss were assessed. Step 3 involved a System Validation using the ALSAS-10U, along with APREL E-020 30 MHz to 6 GHz E-Field Probe Serial Number 225.

References

- IEC-62209 "Human exposure to radio frequency fields from hand-held and body-mounted wireless communication devices – Human models, instrumentation, and procedures"
- Part 2: "Procedure to determine the Specific Absorption Rate (SAR) for hand-held devices used in close proximity of the ear (frequency range of 30 MHz to 6 GHz)"
- TP-D01-032-E020-V2 E-Field probe calibration procedure
- D22-012-Tissue dielectric tissue calibration procedure
- D28-002-Dipole procedure for validation of SAR system using a dipole
- IEEE 1309 Draft Standard for Calibration of Electromagnetic Field Sensors and Probes, Excluding Antennas, from 9kHz to 40GHz

Conditions

Dipole 210-00710 was a recalibration.

Ambient Temperature of the Laboratory: 22 °C +/- 0.5°C
Temperature of the Tissue: 20 °C +/- 0.5°C

Dipole Calibration uncertainty

The calibration uncertainty for the dipole is made up of various parameters presented below.

Mechanical	1%
Positioning Error	1.22%
Electrical	1.7%
Tissue	2.2%
Dipole Validation	2.2%
TOTAL	8.32% (16.64% K=2)

This page has been reviewed for content and attested to by signature within this document.

NCL Calibration Laboratories

Division of APREL Laboratories.

Dipole Calibration Results

Mechanical Verification

APREL Length	APREL Height	Measured Length	Measured Height
68.0 mm	39.5 mm	67.1mm	38.9 mm

Electrical Validation

Tissue	Frequency	SWR:	Return Loss	Impedance
Head	1900MHz	1.084 U	-27.92 dB	52.247 Ω
Body	1900MHz	1.128 U	-24.40 dB	52.618 Ω

Tissue Validation

	Dielectric constant, ϵ_r	Conductivity, σ [S/m]
Head Tissue 1900MHz	40.20	1.38
Body Tissue 1900MHz	52.63	1.46

This page has been reviewed for content and attested to by signature within this document.

NCL Calibration Laboratories

Division of APREL Laboratories.

The Following Graphs are the results as displayed on the Vector Network Analyzer.

S11 Parameter Return Loss

Head: Frequency Range 1.865 to 1.937 GHz

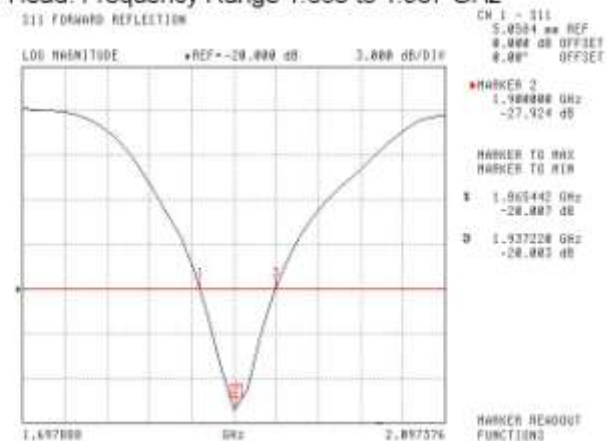

Body: Frequency Range 1.869 to 1.931 MHz

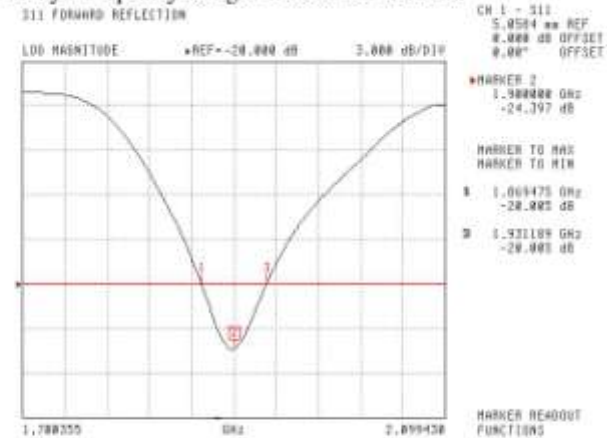

This page has been reviewed for content and attested to by signature within this document.

NCL Calibration Laboratories

Division of APREL Laboratories.

SWR

Head

S11 FORWARD REFLECTION

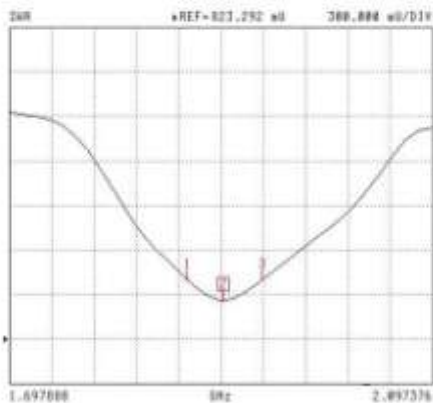

CH 1 - S11
 5.0504 u0 REF
 0.000 dB OFFSET
 0.00° OFFSET

MARKER 2
 1.936888 GHz
 1.054 U

MARKER TO MAX
 MARKER TO MIN

1 1.965440 GHz
 1.226 U

3 1.937228 GHz
 1.224 U

MARKER SENDOUT
 FUNCTIONS

Body

S11 FORWARD REFLECTION

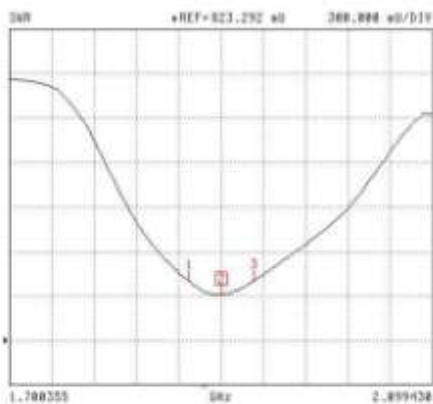

CH 1 - S11
 5.0504 u0 REF
 0.000 dB OFFSET
 0.00° OFFSET

MARKER 2
 1.930888 GHz
 1.128 U

MARKER TO MAX
 MARKER TO MIN

1 1.969473 GHz
 1.223 U

3 1.931188 GHz
 1.223 U

MARKER SENDOUT
 FUNCTIONS

This page has been reviewed for content and attested to by signature within this document.

7

NCL Calibration Laboratories
Division of APREL Laboratories.

Smith Chart Dipole Impedance

Head

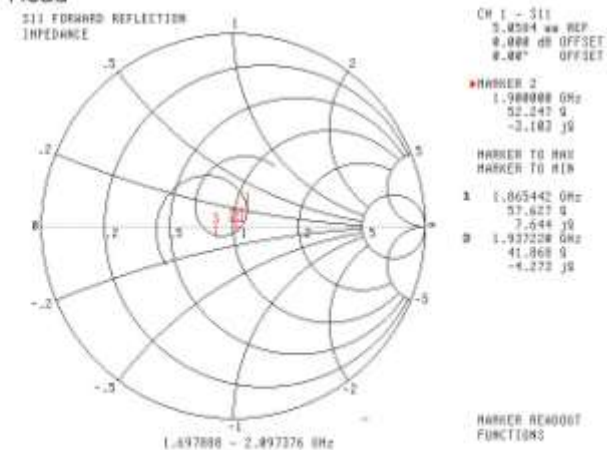

Body

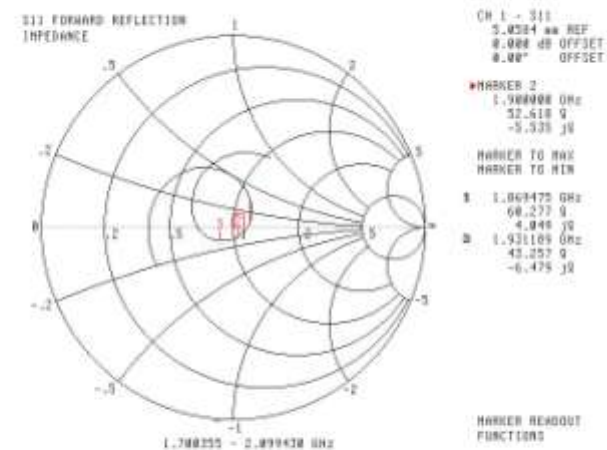

This page has been reviewed for content and attested to by signature within this document.

NCL Calibration Laboratories

Division of APREL Laboratories.

Test Equipment

The test equipment used during Probe Calibration, manufacturer, model number and, current calibration status are listed and located on the main APREL server R:\NCL\Calibration Equipment\Instrument List 2014

This page has been reviewed for content and attested to by signature within this document.

9

APPENDIX D EUT TEST POSITION PHOTOS

Liquid depth $\geq 15\text{cm}$



Body-worn Back Setup Photo

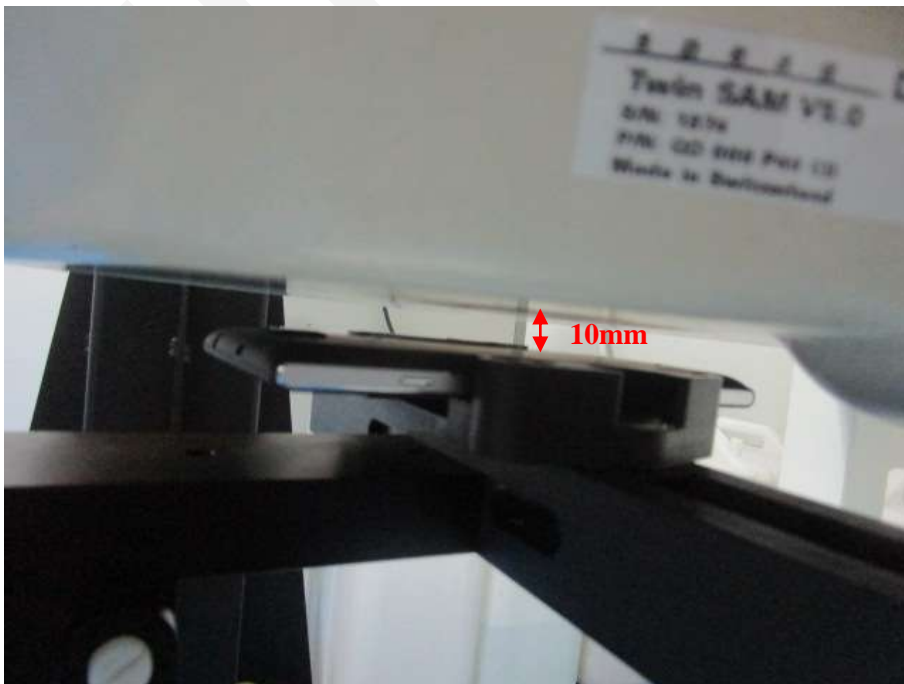

Body-worn Left Setup Photo

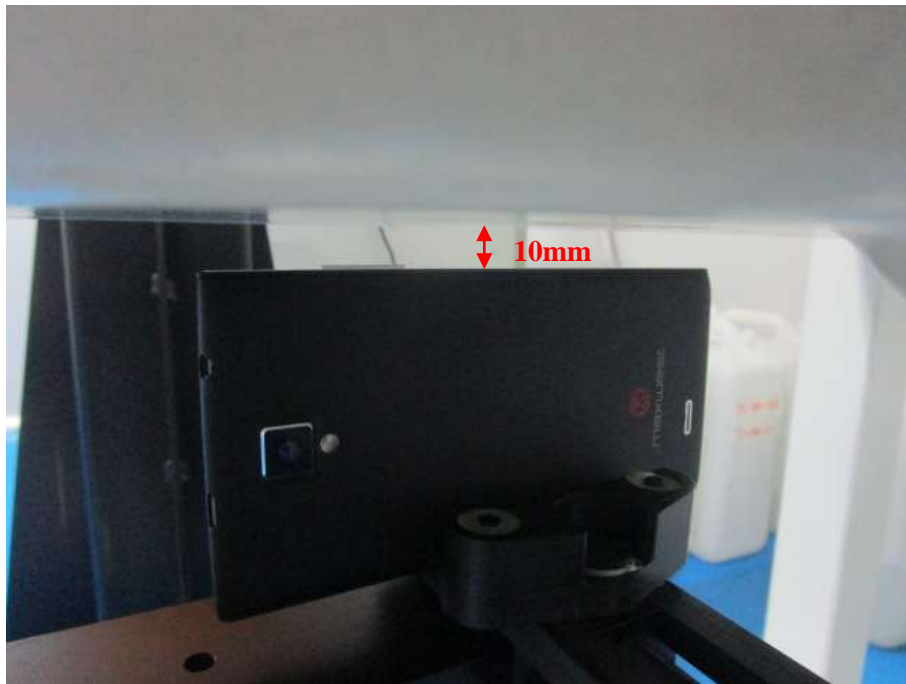

Body-worn Right Setup Photo

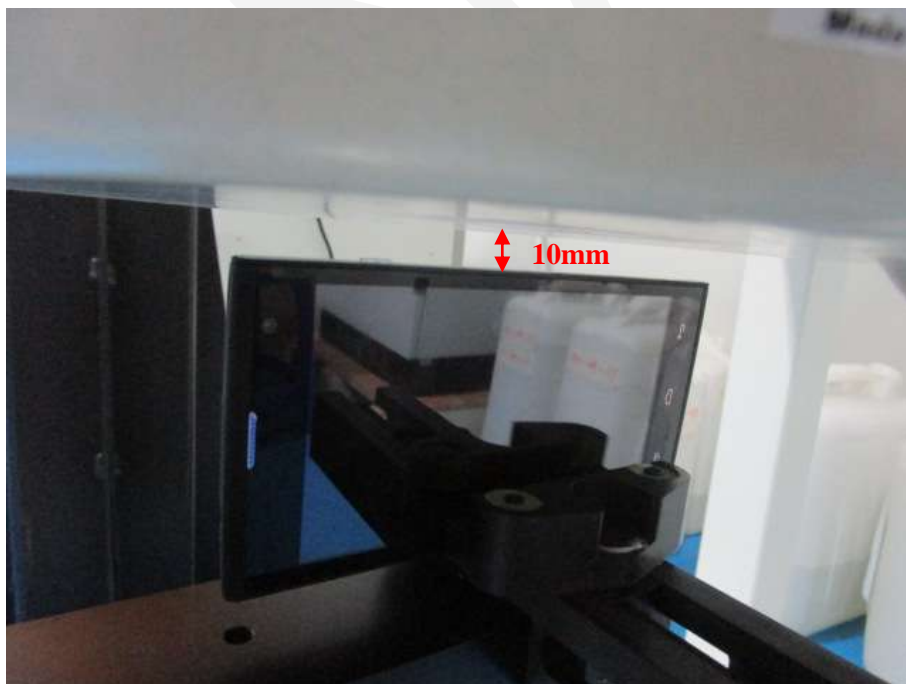

Body-worn Headset Setup Photo

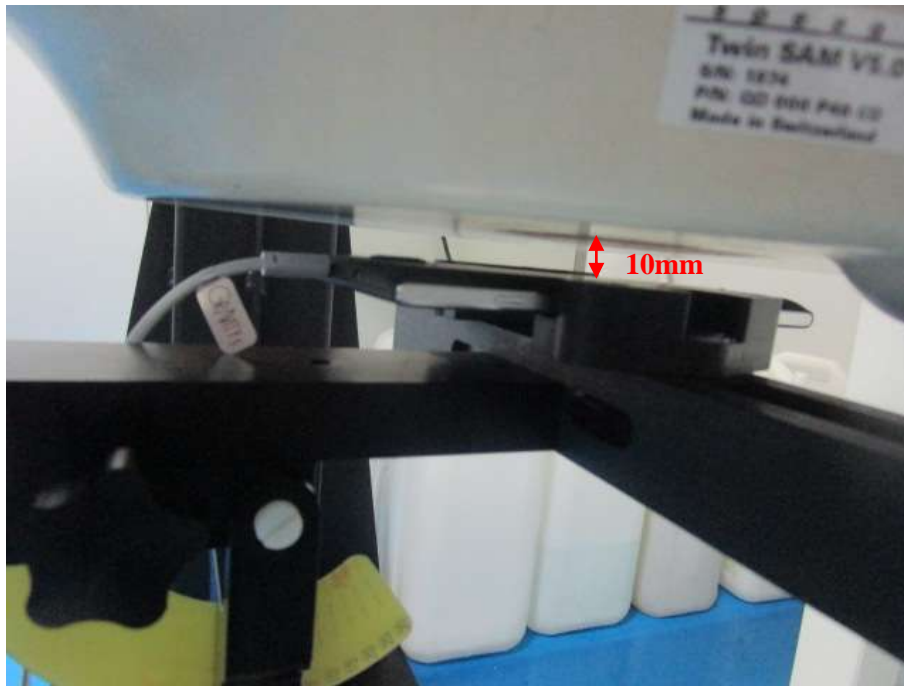

Body-worn Bottom Setup Photo



Left Head Touch Setup Photo

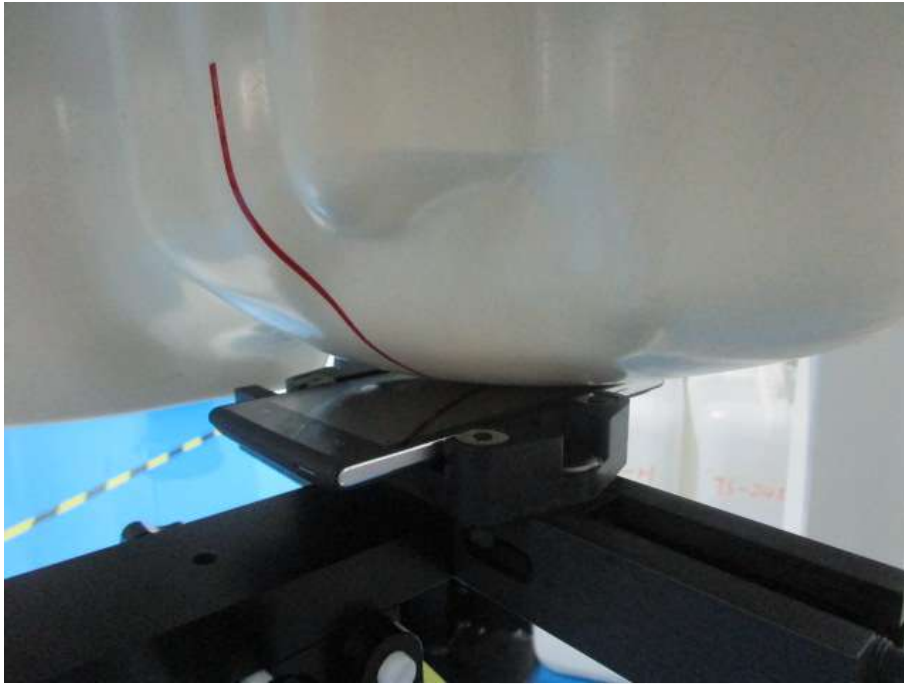

Left Head Tilt Setup Photo

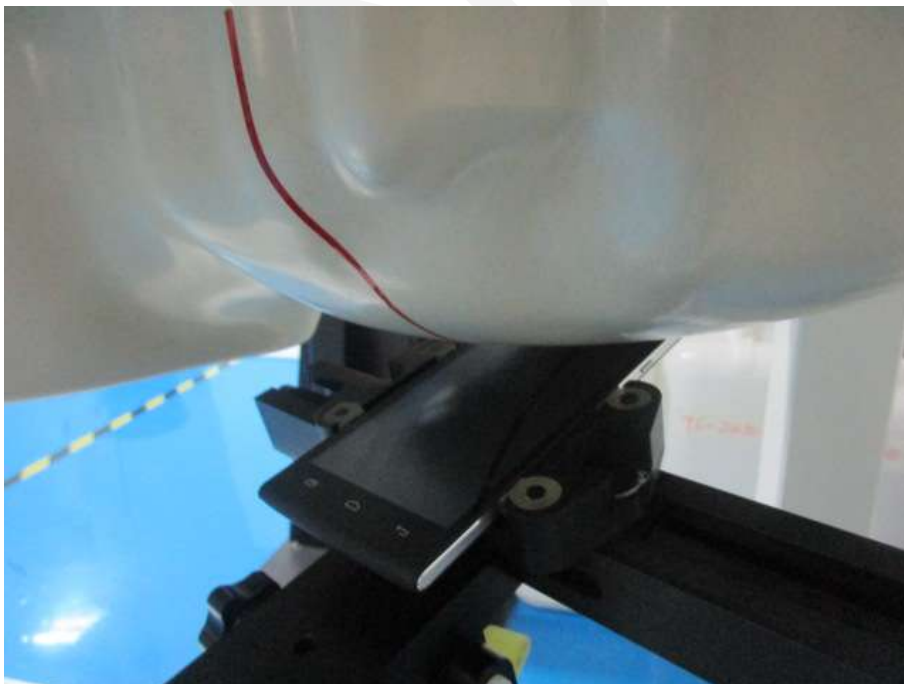

Right Head Touch Setup Photo

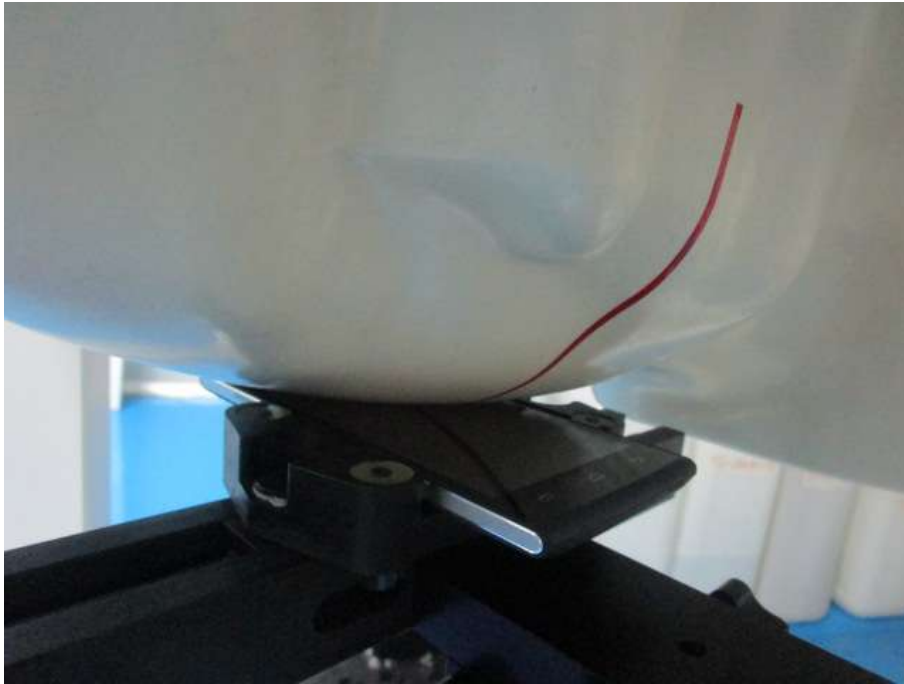

Right Head Tilt Setup Photo



APPENDIX E EUT PHOTOS

EUT – Front View

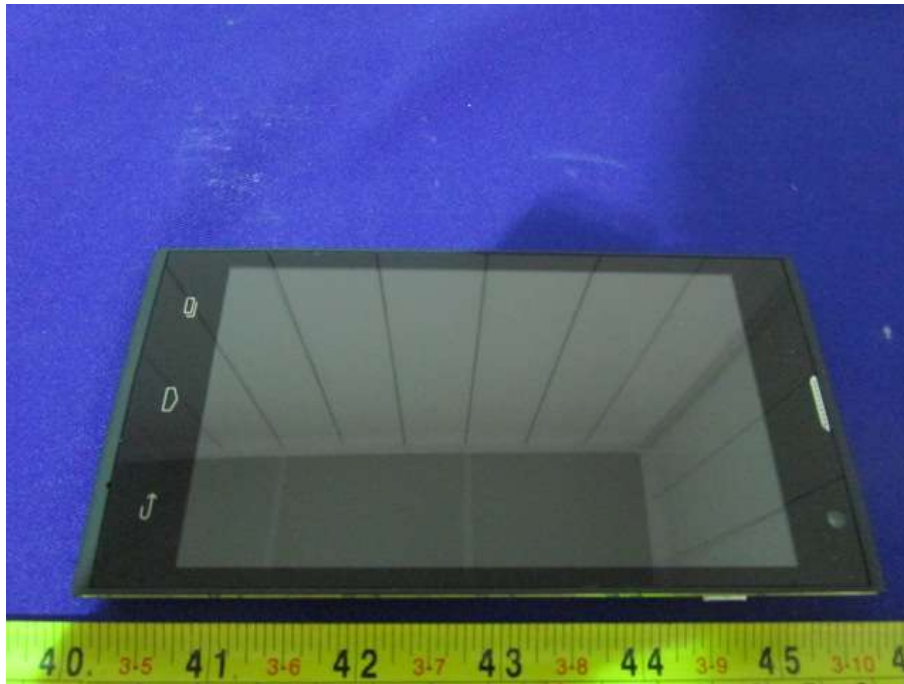

EUT –Back View



EUT – Top Side View

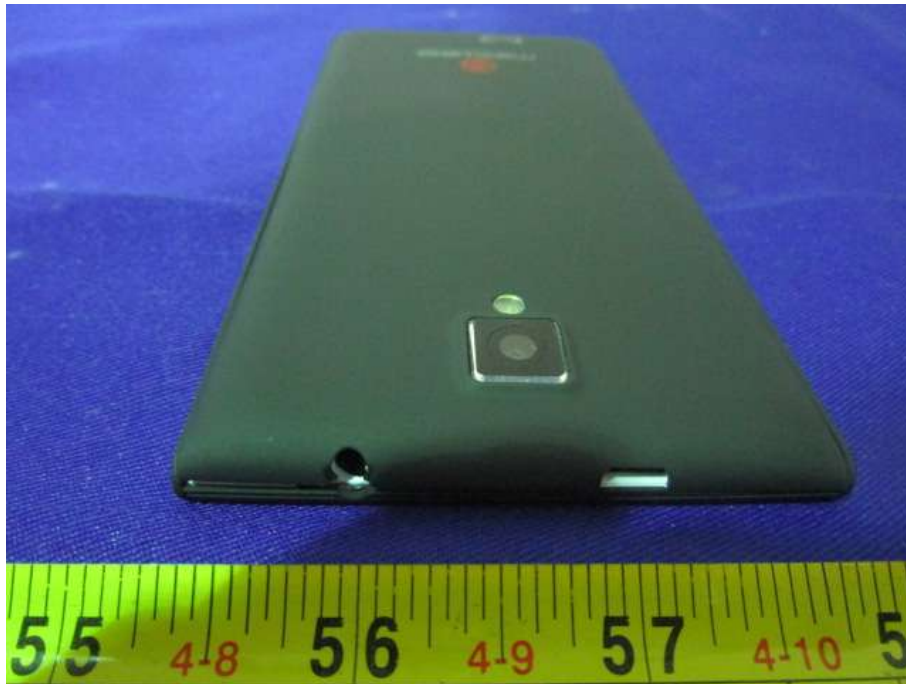

EUT – Bottom Side View



EUT –Left Side View

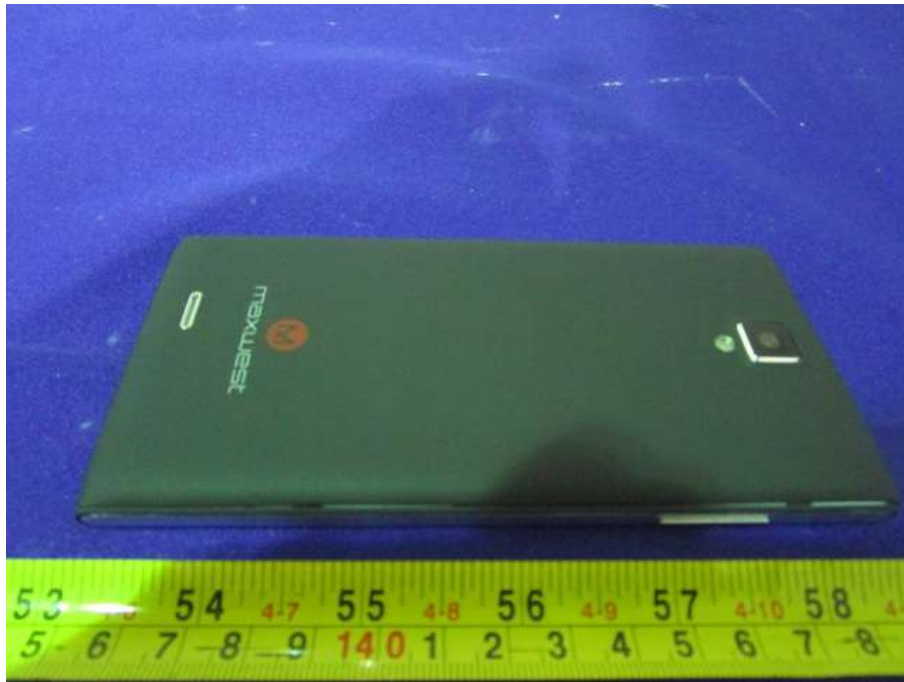

EUT – Right Side View

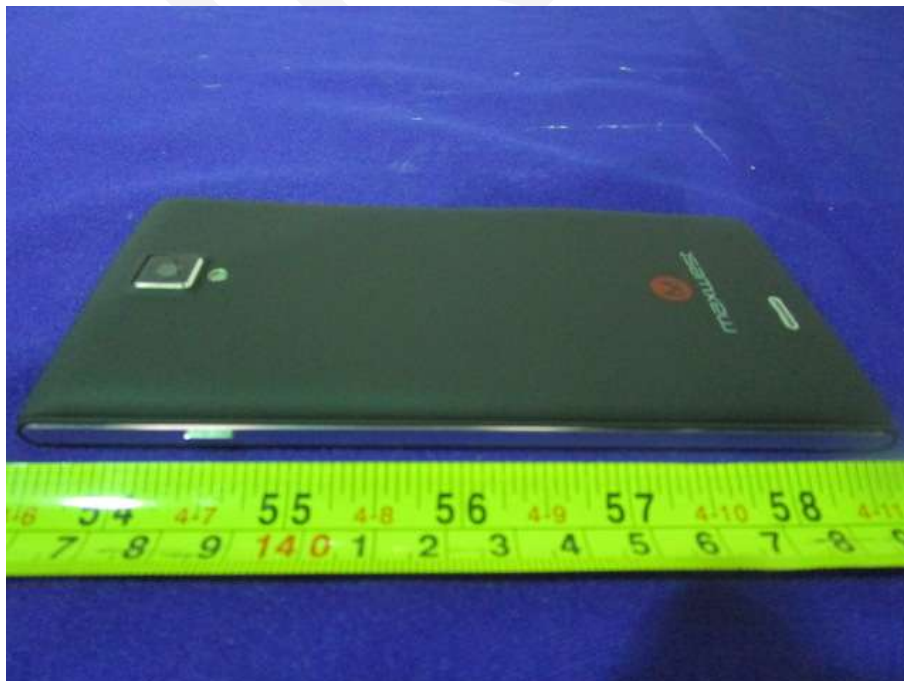

EUT – Cover off View



******* END OF REPORT *******