



Shenzhen CTL Testing Technology Co., Ltd.
Tel: +86-755-89486194 Fax: +86-755-26636041

FCC PART 15 SUBPART C TEST REPORT

Part 15.247

Report Reference No......: **CTL1609183572-WF**

Compiled by

(position+printed name+signature) .: File administrators Happy Guo

Happy Guo

Name of the organization performing the tests

Test Engineer Nice Nong

Nice Nong

(position+printed name+signature) .:

Approved by

(position+printed name+signature) .: Manager Tracy Qi

Tracy Qi

Date of issue.....: Oct. 24, 2016

Test Laboratory Name: **Shenzhen CTL Testing Technology Co., Ltd.**

Address: Floor 1-A, Baisha Technology Park, No.3011, Shahexi Road, Nanshan District, Shenzhen, China 518055

Applicant's name.....: **Huafun International (China) Development Co., Ltd.**

Address: 12A01/12A12 information building Baoyunda, logistic park, Qianjin Road#2, Bao'an, Shenzhen, China

Test specification:

Standard: FCC Part 15.247: Operation within the bands 902–928 MHz, 2400–2483.5 MHz, and 5725–5850 MHz.

TRF Originator.....: Shenzhen CTL Testing Technology Co., Ltd.

Master TRF.....: Dated 2011-01

Shenzhen CTL Testing Technology Co., Ltd. All rights reserved.

This publication may be reproduced in whole or in part for non-commercial purposes as long as the Shenzhen CTL Testing Technology Co., Ltd. is acknowledged as copyright owner and source of the material. Shenzhen CTL Testing Technology Co., Ltd. takes no responsibility for and will not assume liability for damages resulting from the reader's interpretation of the reproduced material due to its placement and context.

Test item description: Camera

FCC ID.....: 2AEMVHFBC03

Trade Mark: Shaghal Ltd

Model/Type reference: EBC105JB, EBM104JB, HF-BC03

Modulation: 802.11b DSSS, 802.11g/n: OFDM

Work Frequency Range: 802.11b/g/n(20MHz): 2412~2462MHz
802.11b/g/n(40MHz): 2422~2452MHz

Antenna Type: Internal

Antenna Gain.....: 2dBi

Result: **Positive**

TEST REPORT

Test Report No. :	CTL1609183572-WF	Oct. 24, 2016
		Date of issue

Equipment under Test : Camera

Model /Type : EBC105JB, EBM104JB, HF-BC03

Applicant : **Huafun International (China) Development Co., Ltd.**

Address : 12A01/12A12 information building Baoyunda, logistic park, Qianjin Road#2, Bao'an, Shenzhen, China

Manufacturer : **Huafun International (China) Development Co., Ltd.**

Address : 12A01/12A12 information building Baoyunda, logistic park, Qianjin Road#2, Bao'an, Shenzhen, China

Test Result according to the standards on page 4:	Positive
--	-----------------

The test report merely corresponds to the test sample.
It is not permitted to copy extracts of these test result without the written permission of the test laboratory.



Contents

1.	<u>TEST STANDARDS</u>	4
2.	<u>SUMMARY</u>	5
2.1.	General Remarks	5
2.2.	Equipment Under Test	5
2.3.	Description of the Equipment under Test (EUT)	5
2.4.	EUT operation mode	6
2.5.	EUT configuration	6
2.6.	NOTE	6
2.7.	Related Submittal(s) / Grant (s)	7
2.8.	Modifications	7
3.	<u>TEST ENVIRONMENT</u>	8
3.1.	Address of the test laboratory	8
3.2.	Test Facility	8
3.3.	Environmental conditions	8
3.4.	Configuration of Tested System	8
3.5.	Duty Cycle	9
3.6.	Statement of the measurement uncertainty	9
3.7.	Equipments Used during the Test	10
3.8.	Summary of Test Result	11
4.	<u>TEST CONDITIONS AND RESULTS</u>	12
4.1.	Conducted Emissions Test	12
4.2.	Radiated Emission and Bandedge Test	15
4.3.	6dB Bandwidth Measurement	23
4.4.	Maximum Peak Output Power	31
4.5.	Power Spectral Density Measurement	33
4.6.	Spurious RF Conducted Emission and bandedge Test	41
4.8.	Antenna Requirement	54
5.	<u>TEST SETUP PHOTOS OF THE EUT</u>	55
6.	<u>EXTERNAL AND INTERNAL PHOTOS OF THE EUT</u>	55

1. TEST STANDARDS

The tests were performed according to following standards:

[FCC Part 15.247](#): Frequency Hopping, Direct Spread Spectrum and Hybrid Systems that are in operation within the bands of 902-928 MHz, 2400-2483.5 MHz, and 5725-5850 MHz.

[ANSI C63.10-2013](#): American National Standard for Testing Unlicensed Wireless Devices.

[ANSI C63.4-2014](#)

[KDB Publication No. 558074 D01 v03r03 Guidance on Measurements for Digital Transmission Systems](#)



2. SUMMARY

2.1. General Remarks

Date of receipt of test sample	:	Sept. 30, 2016
Testing commenced on	:	Sept. 30, 2016
Testing concluded on	:	Oct. 24, 2016

2.2. Equipment Under Test

Power supply system utilised

Power supply voltage	:	<input checked="" type="radio"/> 120V / 60 Hz	<input type="radio"/> 115V / 60Hz
		<input type="radio"/> 12 V DC	<input type="radio"/> 24 V DC
		<input type="radio"/> Other (specified in blank below)	

Description of the test mode

IEEE 802.11b/g/n(HT20): Thirteen channels are provided to the EUT, but only eleventh channels used for USA.

Channel	Frequency(MHz)	Channel	Frequency(MHz)
1	2412	8	2447
2	2417	9	2452
3	2422	10	2457
4	2427	11	2462
5	2432		
6	2437		
7	2442		

IEEE 802.11n(HT40):

Channel	Frequency(MHz)	Channel	Frequency(MHz)
3	2422	8	2447
4	2427	9	2452
5	2432		
6	2437		
7	2442		

2.3. Description of the Equipment under Test (EUT)

Product Name:	Camera
Model/Type reference:	EBM104JB
Power supply:	DC 5V from AC adapter
WIFI	
Supported type:	802.11b/802.11g/802.11n(HT20) /802.11n(HT40)
Modulation:	802.11b: DSSS 802.11g/802.11n(HT20)/802.11n(HT40): OFDM
Operation frequency:	802.11b/802.11g/802.11n(HT20): 2412MHz~2462MHz 802.11n(HT40): 2422MHz~2452MHz
Channel number:	802.11b/802.11g/802.11n(HT20): 11 802.11n(HT40):7

3. The EUT incorporates a SISO function, Physically, the EUT provides one completed transmitter and one completed receivers.

Modulation Mode	TX Function
802.11b	1TX
802.11g	1TX
802.11n (20MHz)	1TX
802.11n(40MHz)	1TX

2.7. Related Submittal(s) / Grant (s)

This submittal(s) (test report) is intended for FCC ID: 2AEMVHFBC03 filing to comply with of the FCC part15C

Rules.

2.8. Modifications

No modifications were implemented to meet testing criteria.



3. TEST ENVIRONMENT

3.1. Address of the test laboratory

Shenzhen CTL Testing Technology Co., Ltd.
 Floor 1-A, Baisha Technology Park, No.3011, Shahexi Road, Nanshan District, Shenzhen, China 518055

The sites are constructed in conformance with the requirements of ANSI C63.7, ANSI C63.10 (2013) and CISPR Publication 22.

3.2. Test Facility

The test facility is recognized, certified, or accredited by the following organizations:

IC Registration No.: 9618B

The 3m alternate test site of Shenzhen CTL Testing Technology Co., Ltd. EMC Laboratory has been registered by Certification and Engineer Bureau of Industry Canada for the performance of with Registration No.: 9618B on November 13, 2013.

FCC-Registration No.: 970318

Shenzhen CTL Testing Technology Co., Ltd. EMC Laboratory has been registered and fully described in a report filed with the (FCC) Federal Communications Commission. The acceptance letter from the FCC is maintained in our files. Registration 970318, December 19, 2013.

3.3. Environmental conditions

During the measurement the environmental conditions were within the listed ranges:

Temperature:	15-35 ° C
Humidity:	30-60 %
Atmospheric pressure:	950-1050mbar

3.4. Configuration of Tested System

Fig. 2-1 Configuration of Tested System

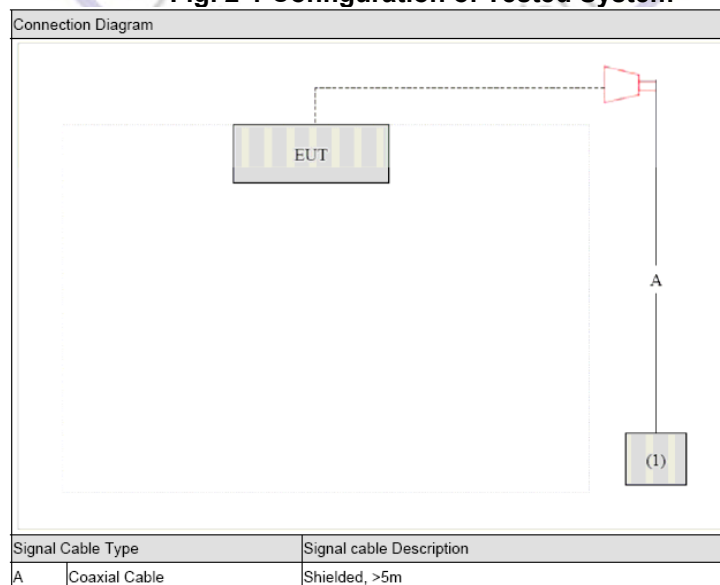

3.5. Duty Cycle

Operated Mode for Worst Duty Cycle		
<input type="checkbox"/>	Operated normally mode for worst duty cycle	
<input checked="" type="checkbox"/>	Operated test mode for worst duty cycle	
Mode	Duty Cycle (%)	Duty Factor (dB)
11b	100	0
11g	100	0
11n HT20	100	0
11n HT40	100	0

3.6. Statement of the measurement uncertainty

The data and results referenced in this document are true and accurate. The reader is cautioned that there may be errors within the calibration limits of the equipment and facilities. The measurement uncertainty was calculated for all measurements listed in this test report acc. to CISPR 16 - 4 „Specification for radio disturbance and immunity measuring apparatus and methods – Part 4: Uncertainty in EMC Measurements“ and is documented in the Shenzhen CTL Testing Technology Co., Ltd. quality system acc. to DIN EN ISO/IEC 17025. Furthermore, component and process variability of devices similar to that tested may result in additional deviation. The manufacturer has the sole responsibility of continued compliance of the device.

Hereafter the best measurement capability for CTL laboratory is reported:

Test	Range	Measurement Uncertainty	Notes
Radiated Emission	30~1000MHz	4.10dB	(1)
Radiated Emission	1~12.75GHz	4.32dB	(1)
Radiated Emission	12.75GHz-25 GHz	4.68dB	(1)
Conducted Disturbance	0.15~30MHz	3.20dB	(1)

- (1) This uncertainty represents an expanded uncertainty expressed at approximately the 95% confidence level using a coverage factor of k=2.

3.7. Equipments Used during the Test

Test Equipment	Manufacturer	Model No.	Serial No.	Calibration Date	Calibration Due Date
ULTRA-ROADBAND ANTENNA	Sunol Sciences Corp.	JB1	A061713	2016/06/02	2017/06/01
EMI Test Receiver	R&S	ESCI	103710	2016/06/02	2017/06/01
Spectrum Analyzer	Agilent	E4407B	MY41440676	2016/05/21	2017/05/20
Controller	EM Electronics	Controller EM 1000	N/A	2016/05/21	2017/05/20
Horn Antenna	Sunol Sciences Corp.	DRH-118	A062013	2016/05/19	2017/05/18
Active Loop Antenna	Daze	ZN30900A	N/A	2016/05/19	2017/05/18
LISN	R&S	ENV216	3560.6550.12	2016/06/02	2017/06/01
LISN	R&S	ESH2-Z5	860014/010	2016/06/02	2017/06/01
ISN	FCC	F-071115-1057-1-09	11229	2016/05/19	2017/05/18
Amplifier	Agilent	8349B	3008A02306	2016/05/19	2017/05/18
Amplifier	Agilent	8447D	2944A10176	2016/05/19	2017/05/18
Transient Limiter	SCHWARZCECK	VTSD 9561F	9666	2016/06/02	2017/06/01
Radio Communication Tester	R&S	CMU200	115419	2016/05/22	2017/05/21
Temperature/Humidity Meter	Gangxing	CTH-608	02	2016/05/20	2017/05/19
SIGNAL GENERATOR	Agilent	E4421B	US40051744	2016/05/20	2017/05/19
Power Meter	Agilent	U2531A	TW53323507	2016/05/21	2017/05/20
Power Sensor	Agilent	U2021XA	MY5365004	2016/05/21	2017/05/20
Climate Chamber	ESPEC	EL-10KA	A20120523	2016/05/20	2017/05/19
High-Pass Filter	K&L	9SH10-2700/X12750-O/O	N/A	2016/05/20	2017/05/19
High-Pass Filter	K&L	41H10-1375/U12750-O/O	N/A	2016/05/20	2017/05/19
RF Cable	HUBER+SUHNER	RG214	N/A	2016/05/20	2017/05/19

3.8. Summary of Test Result

FCC PART 15		
FCC Part 15.207	AC Power Conducted Emission	PASS
FCC Part 15.247(a)(2)	6dB Bandwidth	PASS
FCC Part 15.247(d)	Spurious RF Conducted Emission	PASS
FCC Part 15.247(b)	Maximum Peak Output Power	PASS
FCC Part 15.247(e)	Power Spectral Density	PASS
FCC Part 15.109/ 15.205/ 15.209	Radiated Emissions	PASS
FCC Part 15.247(d)	Band Edge Compliance of RF Emission	PASS
FCC Part 15.203/15.247 (b)	Antenna Requirement	PASS

Remark: The measurement uncertainty is not included in the test result.

Preliminary tests were performed in different data rate to find the worst radiated emission. The data rate shown in the table below is the worst-case rate with respect to the specific test item. Investigation has been done on all the possible configurations for searching the worst cases. The following table is a list of the test modes shown in this test report.

Test Items	Mode	Data Rate	Channel
AC Power Conducted Emission	Normal Link	11 Mbps	1
Maximum Peak Conducted Output Power Power Spectral Density 6dB Bandwidth Spurious RF conducted emission	11b/DSSS	11 Mbps	1/6/11
	11g/OFDM	54 Mbps	1/6/11
	11n(20MHz)/OFDM	65Mbps	1/6/11
	11n(40MHz)/OFDM	150Mbps	3/6/9
Radiated Emission 30MHz~1GHz	11b/DSSS	11 Mbps	1/6/11
	11g/OFDM	54 Mbps	1/6/11
	11n(20MHz)/OFDM	65Mbps	1/6/11
	11n(40MHz)/OFDM	150Mbps	3/6/9
Radiated Emission 1GHz~10th Harmonic	11b/DSSS	11 Mbps	1/6/11
	11g/OFDM	54 Mbps	1/6/11
	11n(20MHz)/OFDM	65Mbps	1/6/11
	11n(40MHz)/OFDM	150Mbps	3/6/9
Band Edge Compliance of RF Emission	11b/DSSS	11 Mbps	1/11
	11g/OFDM	54 Mbps	1/11
	11n(20MHz)/OFDM	65Mbps	1/11
	11n(40MHz)/OFDM	150Mbps	3/9

Note1: According exploratory test, EUT will have maximum output power in those data rate, so those data rate were used for all test.

4. TEST CONDITIONS AND RESULTS

4.1. Conducted Emissions Test

TEST CONFIGURATION

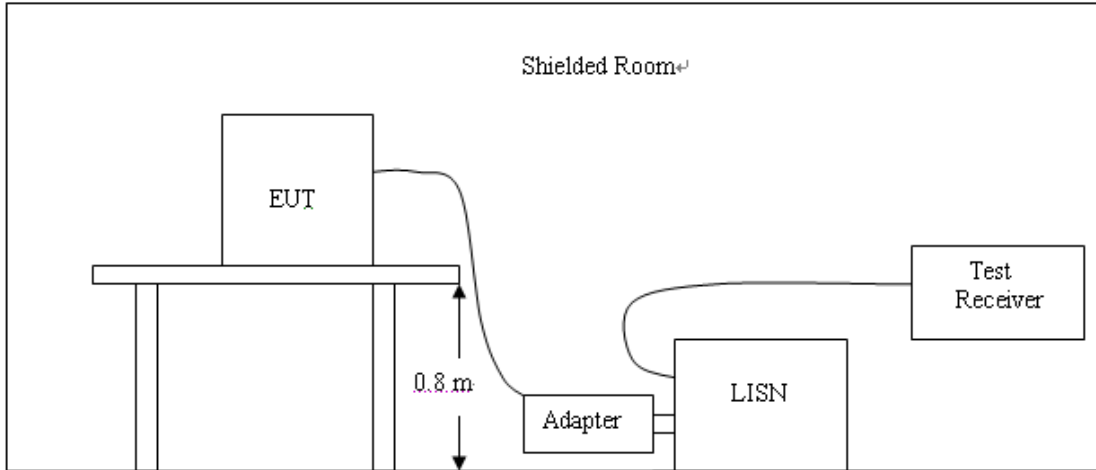

TEST PROCEDURE

For unintentional device, according to § 15.107(a) Line Conducted Emission Limits is as following:

Frequency (MHz)	Maximum RF Line Voltage (dB μ v)			
	CLASS A		CLASS B	
	Q.P.	Ave.	Q.P.	Ave.
0.15 - 0.50	79	66	66-56*	56-46*
0.50 - 5.00	73	60	56	46
5.00 - 30.0	73	60	60	50

* Decreasing linearly with the logarithm of the frequency

For intentional device, according to §15.207(a) Line Conducted Emission Limit is same as above table.

1. Please follow the guidelines in ANSI C63.10-2013.
2. The EUT was placed 0.4 meter from the conducting wall of the shielding room was kept at least 80 centimeters from any other grounded conducting surface.
3. Connect EUT to the power mains through a line impedance stabilization network (LISN).
4. All the support units are connecting to the other LISN.
5. The LISN provides 50 ohm coupling impedance for the measuring instrument.
6. The FCC states that a 50 ohm, 50 microhenry LISN should be used.
7. Both sides of AC line were checked for maximum conducted interference.
8. The frequency range from 150 kHz to 30 MHz was searched.
9. Set the test-receiver system to Peak Detect Function and specified bandwidth with Maximum Hold Mode.

The RBW/VBW for 150KHz to 30MHz: 9KHz

TEST RESULTS

SCAN TABLE: "Voltage (9K-30M) FIN"

Short Description: 150K-30M Voltage

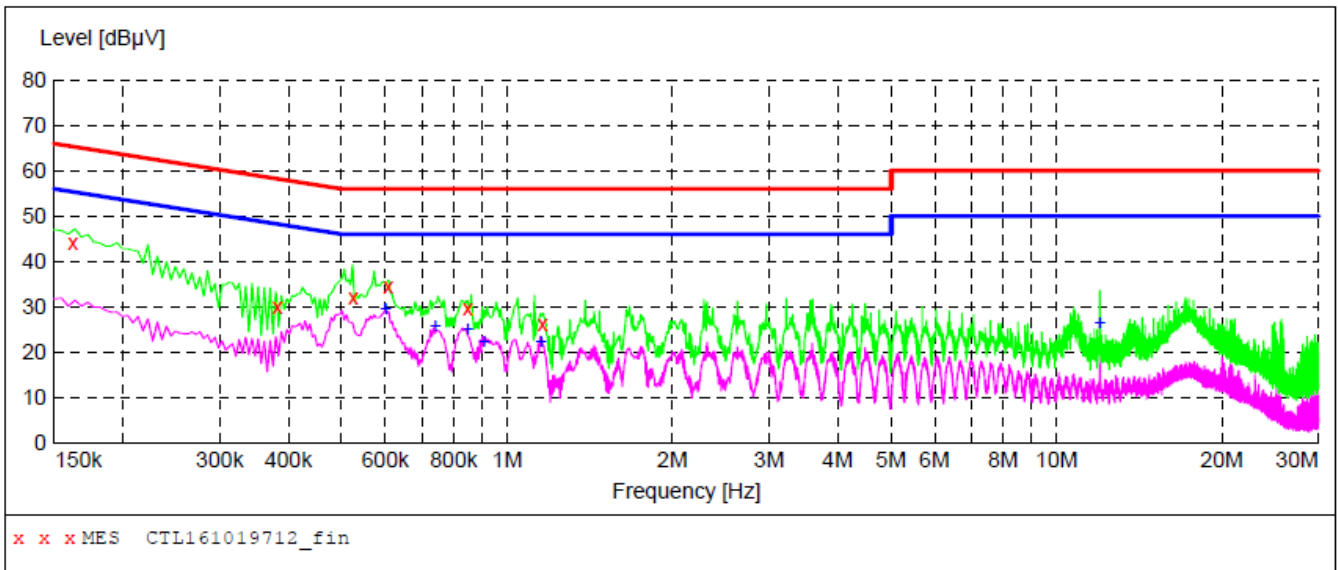

MEASUREMENT RESULT: "CTL161019712_fin"

10/19/2016 12:35PM

Frequency MHz	Level dBµV	Transd dB	Limit dBµV	Margin dB	Detector	Line	PE
0.162000	44.00	10.2	65	21.4	QP	L1	GND
0.382000	30.10	10.2	58	28.1	QP	L1	GND
0.524000	31.90	10.2	56	24.1	QP	L1	GND
0.608000	34.30	10.2	56	21.7	QP	L1	GND
0.848000	29.70	10.2	56	26.3	QP	L1	GND
1.160000	26.10	10.3	56	29.9	QP	L1	GND

MEASUREMENT RESULT: "CTL161019712_fin2"

10/19/2016 12:35PM

Frequency MHz	Level dBµV	Transd dB	Limit dBµV	Margin dB	Detector	Line	PE
0.602000	29.60	10.2	46	16.4	AV	L1	GND
0.740000	25.70	10.2	46	20.3	AV	L1	GND
0.848000	25.10	10.2	46	20.9	AV	L1	GND
0.908000	22.40	10.2	46	23.6	AV	L1	GND
1.154000	22.20	10.3	46	23.8	AV	L1	GND
12.002000	26.50	10.6	50	23.5	AV	L1	GND

SCAN TABLE: "Voltage (9K-30M)FIN"

Short Description: 150K-30M Voltage

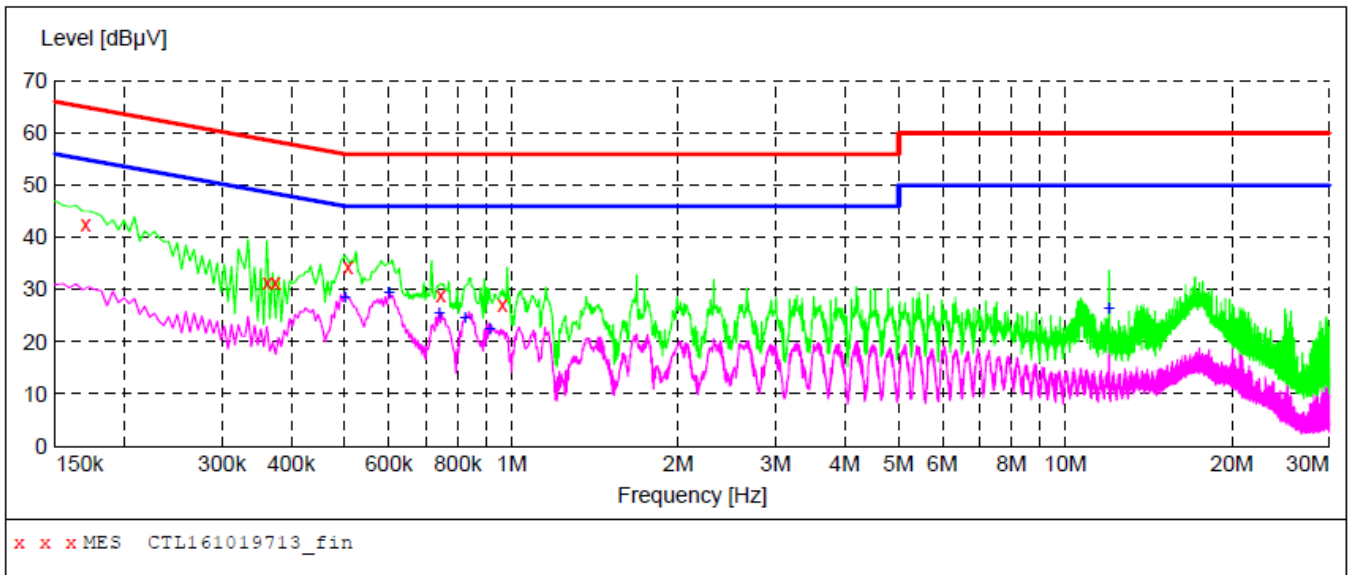

MEASUREMENT RESULT: "CTL161019713_fin"

10/19/2016 12:38PM

Frequency MHz	Level dBµV	Transd dB	Limit dBµV	Margin dB	Detector	Line	PE
0.170000	42.60	10.2	65	22.4	QP	N	GND
0.362000	31.50	10.2	59	27.2	QP	N	GND
0.374000	31.40	10.2	58	27.0	QP	N	GND
0.506000	34.30	10.2	56	21.7	QP	N	GND
0.746000	28.80	10.2	56	27.2	QP	N	GND
0.962000	27.20	10.3	56	28.8	QP	N	GND

MEASUREMENT RESULT: "CTL161019713_fin2"

10/19/2016 12:38PM

Frequency MHz	Level dBµV	Transd dB	Limit dBµV	Margin dB	Detector	Line	PE
0.500000	28.60	10.2	46	17.4	AV	N	GND
0.602000	29.50	10.2	46	16.5	AV	N	GND
0.740000	25.60	10.2	46	20.4	AV	N	GND
0.824000	24.60	10.2	46	21.4	AV	N	GND
0.914000	22.70	10.3	46	23.3	AV	N	GND
12.002000	26.60	10.6	50	23.4	AV	N	GND

4.2. Radiated Emission and Bandedge Test

TEST CONFIGURATION

(A) Radiated Emission Test Set-Up, Frequency Below 30MHz

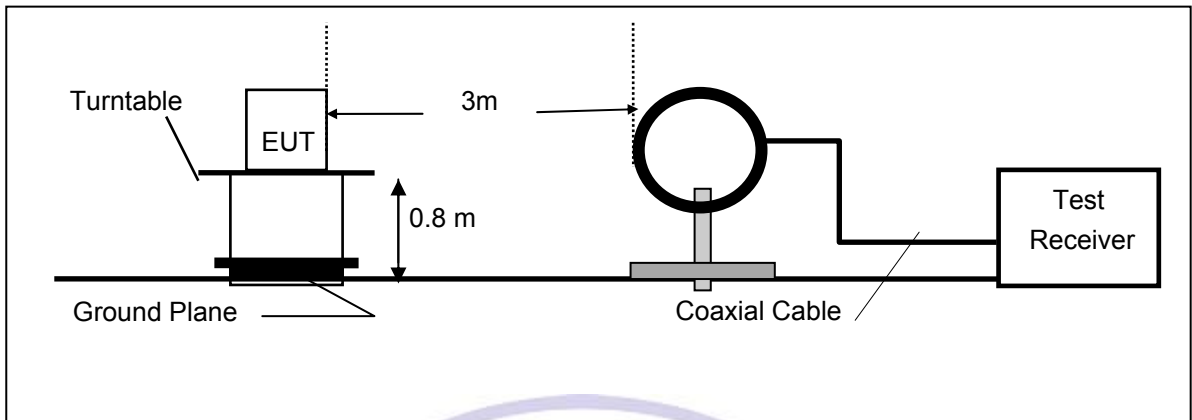

(B) Radiated Emission Test Set-Up, Frequency Below 1000MHz

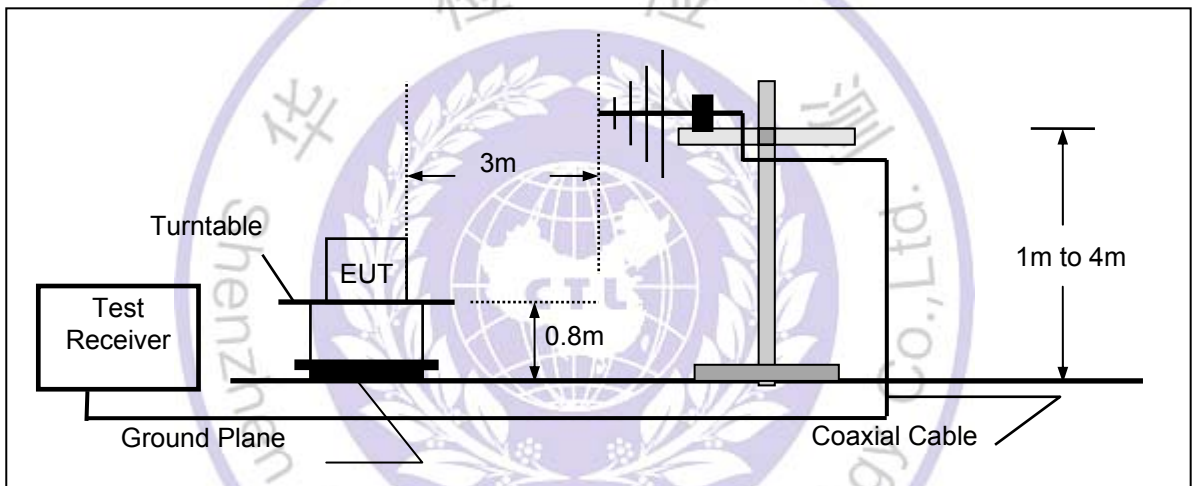

(C) Radiated Emission Test Set-Up, Frequency above 1000MHz

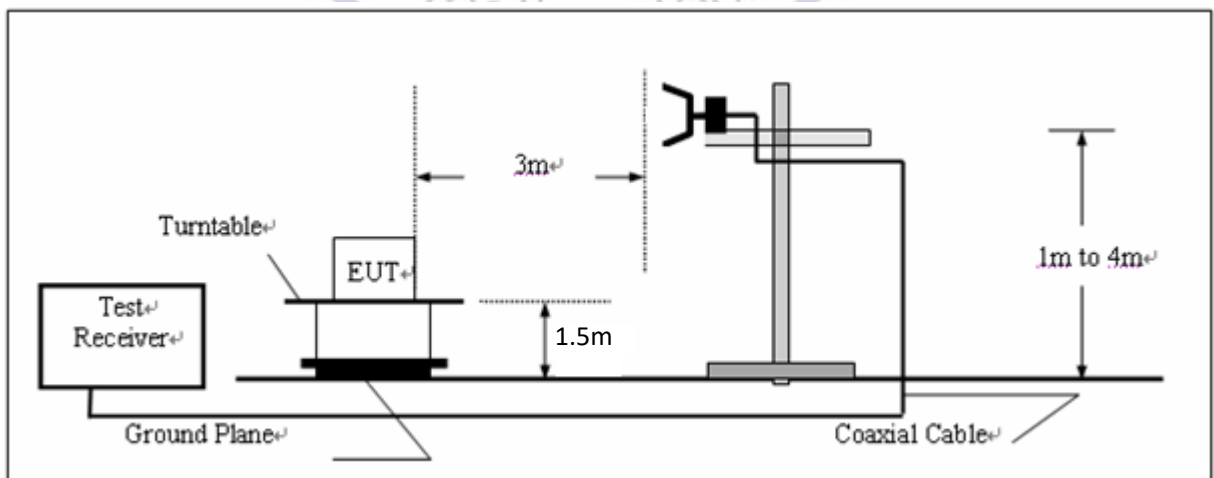

FIELD STRENGTH CALCULATION

The field strength is calculated by adding the Antenna Factor and Cable Factor and subtracting the Amplifier Gain and Duty Cycle Correction Factor(if any) from the measured reading. The basic equation with a sample calculation is as follows:

$$FS = RA + AF + CL - AG$$

Where FS = Field Strength	CL = Cable Attenuation Factor (Cable Loss)
RA = Reading Amplitude	AG = Amplifier Gain
AF = Antenna Factor	

TEST PROCEDURE

1. The EUT is placed on a turntable, which is 0.8m above ground plane below 1GHz and 1.5m above ground plane above 1GHz.
2. The turntable shall be rotated for 360 degrees to determine the position of maximum emission level.
3. EUT is set 3m away from the receiving antenna, which is varied from 1m to 4m to find out the highest emissions.
4. For the radiated emission test above 1GHz: Place the measurement antenna away from each area of the EUT determined to be a source of emissions at the specified measurement distance, while keeping the measurement antenna aimed at the source of emissions at each frequency of significant emissions, with polarization oriented for maximum response. The measurement antenna may have to be higher or lower than the EUT, depending on the radiation pattern of the emission and staying aimed at the emission source for receiving the maximum signal. The final measurement antenna elevation shall be that which maximizes the emissions. The measurement antenna elevation for maximum emissions shall be restricted to a range of heights of from 1 m to 4 m above the ground or reference ground plane.
5. Maximum procedure was performed on the six highest emissions to ensure EUT compliance.
6. And also, each emission was to be maximized by changing the polarization of receiving antenna both horizontal and vertical.
7. Repeat above procedures until the measurements for all frequencies are complete.
8. Based on the Frequency Generator in the device include 16MHz. The test frequency range from 9KHz to 25GHz per FCC PART 15.33(a).

Note: 1. Three axes are chosen for pretest, the Y axis is the worst mode for final test.
2. When doing emission measurement above 1GHz, the horn antenna will be bended down a little (as horn antenna has the narrow beamwidth) in order to keeping the antenna in the "cone of radiation" of EUT. The 3dB beamwidth is 60 degrees for H-plane and 90 degrees for E-plane.

LIMIT

For unintentional device, according to § 15.109(a), except for Class A digital devices, the field strength of radiated emissions from unintentional radiators at a distance of 3 meters shall not exceed the following values:

Frequency (MHz)	Distance (Meters)	Radiated (dBµV/m)	Radiated (µV/m)
30-88	3	40.0	100
88-216	3	43.5	150
216-960	3	46.0	200
Above 960	3	54.0	500

For intentional device, according to § 15.209(a), the general requirement of field strength of radiated emissions from intentional radiators at a distance of 3 meters shall not exceed the above table. According to § 15.247(d), in any 100kHz bandwidth outside the frequency band in which the EUT is operating, the radio frequency power that is produced by the intentional radiator shall be at least 20dB below that in the 100kHz bandwidth within the band that contains the highest level of desired power.

TEST RESULTS

9KHz-30MHz:

Freq. (MHz)	Level (dBuV)	Over Limit (dB)	Limit Line (dBuV)	Remark
-	-	-	-	See Note

Note: The amplitude of spurious emissions that are attenuated by more than 20dB below the permissible value has no need to be reported.

Distance extrapolation factor= 40 log (specific distance/ test distance) (dB);
 Limit line= specific limits (dBuV) + distance extrapolation factor.

Below 1GHz:

The radiated measurement are performed the each test mode (b/g/n) and channel (low/mid/high), the datum recorded below (802.11b mode, the middle channel) is the worst case for all the test mode and channel.

SWEEP TABLE: "test (30M-1G)"

Short Description:		Field Strength			
Start	Stop	Detector	Meas. Time	IF Bandw.	Transducer
30.0 MHz	1.0 GHz	MaxPeak	300.0 ms	120 kHz	JB1

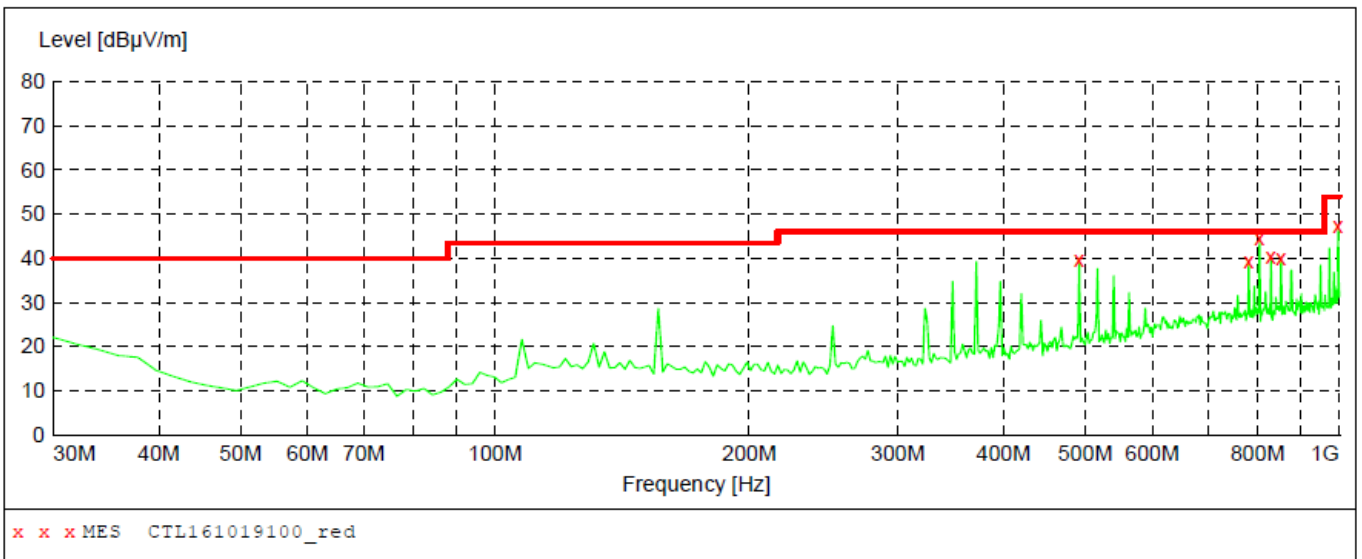

MEASUREMENT RESULT: "CTL161019100_red"

10/19/2016 8:46AM

Frequency MHz	Level dBuV/m	Transd dB	Limit dBuV/m	Margin dB	Det.	Height cm	Azimuth deg	Polarization
491.720000	39.80	20.1	46.0	6.2	---	0.0	0.00	HORIZONTAL
780.780000	39.50	24.5	46.0	6.5	---	0.0	0.00	HORIZONTAL
804.060000	44.50	24.7	46.0	1.5	---	0.0	0.00	HORIZONTAL
829.280000	40.30	25.0	46.0	5.7	---	0.0	0.00	HORIZONTAL
852.560000	40.20	25.2	46.0	5.8	---	0.0	0.00	HORIZONTAL
996.120000	47.50	27.2	53.9	6.4	---	0.0	0.00	HORIZONTAL

SWEEP TABLE: "test (30M-1G)"

Short Description:		Field Strength			
Start	Stop	Detector	Meas. Time	IF Bandw.	Transducer
30.0 MHz	1.0 GHz	MaxPeak	300.0 ms	120 kHz	JB1

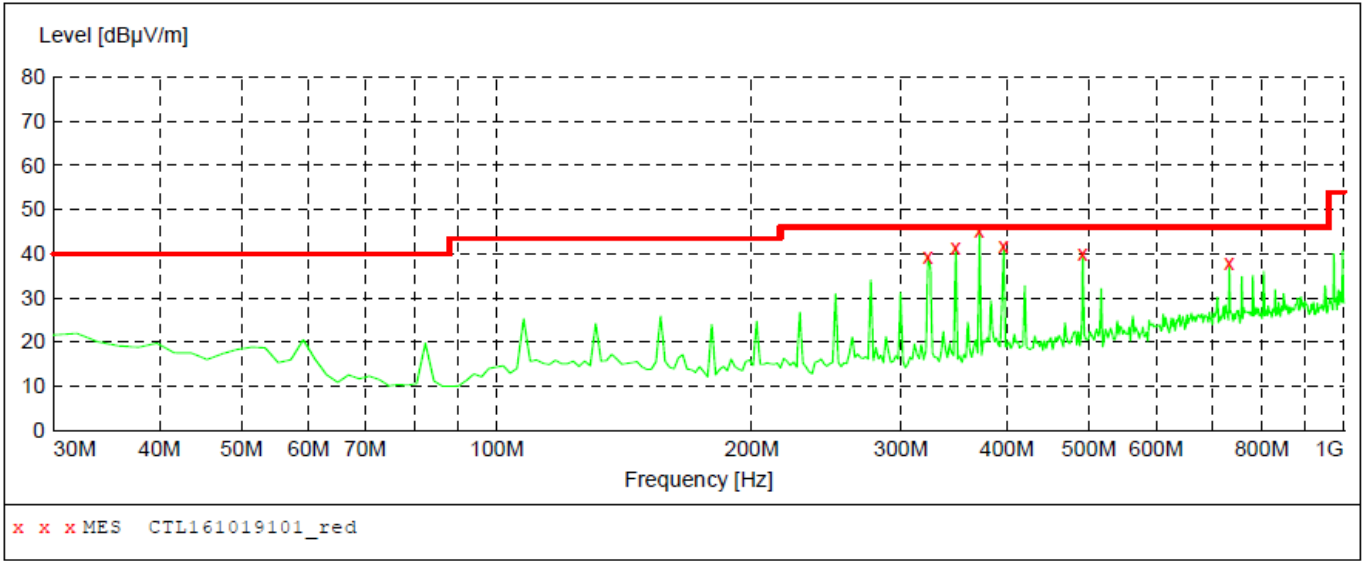

MEASUREMENT RESULT: "CTL161019101_red"

10/19/2016 8:51AM

Frequency MHz	Level dBµV/m	Transd dB	Limit dBµV/m	Margin dB	Det.	Height cm	Azimuth deg	Polarization
322.940000	39.30	15.9	46.0	6.7	---	0.0	0.00	VERTICAL
348.160000	41.40	16.7	46.0	4.6	---	0.0	0.00	VERTICAL
371.440000	45.10	17.5	46.0	0.9	---	0.0	0.00	VERTICAL
396.660000	41.90	17.9	46.0	4.1	---	0.0	0.00	VERTICAL
491.720000	39.90	20.1	46.0	6.1	---	0.0	0.00	VERTICAL
732.280000	37.80	23.8	46.0	8.2	---	0.0	0.00	VERTICAL



Above 1GHz:

802.11b

CH	Antenna	Frequency (MHz)	Reading Level (dBuV/m)	Factor (dB)	Measure Level (dBuV/m)	Limit (dBuV/m)	Margin (dB)	Detector
1	V	2412	84.4	30.8	115.2	Fundamental	/	PK
	V	3200	9.8	31.1	40.9	54(note3)	13.1	PK
	V	2390	37.0	32.2	69.2	74	4.8	PK
	V	2390	18.7	32.2	50.9	54	3.1	AV
	V	2400	38.7	32.1	70.8	74	3.2	PK
	V	2400	19.3	32.1	51.4	54	2.6	AV
	V	4824	9.6	42.6	52.2	54(note3)	1.8	PK
	V	7236	20.6	46.5	67.1	74	6.9	PK
	V	7236	2.8	46.5	49.3	54	4.7	AV
	H	24000	11.7	38.9	50.6	54	3.4	PK
6	V	2437	83.7	31.2	114.9	Fundamental	/	PK
	V	3200	10.6	31.1	41.7	54(note3)	12.3	PK
	V	4876	18.8	32.8	51.6	54(note3)	2.4	PK
	V	7311	21.4	46.8	68.2	74	5.8	PK
	V	7311	4.6	46.1	50.7	54	3.3	AV
	H	24000	11.7	38.9	50.6	54	3.4	PK
11	V	2462.3	83.9	30.9	114.8	Fundamental	/	PK
	V	3200	12.4	31.1	43.5	54(note3)	10.5	PK
	V	2483.5	32.9	30.2	63.1	74	10.9	PK
	V	2483.5	15.0	30.2	45.2	54	8.8	AV
	V	4927	18.9	32.5	51.4	54(note3)	2.6	PK
	V	7386	22.3	46.3	68.6	74	5.4	PK
	V	7386	3.0	46.3	49.3	54	4.7	AV
	H	24000	11.7	38.9	50.6	54	3.4	PK

Note: 1. Measure Level = Reading Level + Factor.

2. The test results which are attenuated more than 20 dB below the permissible value limit (the test frequency range: 9kHz~30MHz, 18GHz~25GHz), therefore no data appear in the report.

3. This limit applies for using average detector, if the test result on peak is lower than average limit, then average measurement needn't be performed.

Remark: RBW 1MHz VBW 3MHz peak detector for PK value, RMS detector for AV value

802.11g

CH	Antenna	Frequency (MHz)	Reading Level (dBuV/m)	Factor (dB)	Measure Level (dBuV/m)	Limit (dBuV/m)	Margin (dB)	Detector
1	V	2411.9	84.1	30.8	114.9	Fundamental	/	PK
	V	3200	14.1	31.1	45.2	54(note3)	8.8	PK
	V	2390	37.2	32.2	69.4	74	4.6	PK
	V	2390	17.9	32.2	50.1	54	3.9	AV
	V	2400	39.5	32.1	71.6	74	2.4	PK
	V	2400	20.2	32.1	52.3	54	1.7	AV
	V	4824	9.9	42.6	52.5	54(note3)	1.5	PK
	V	7236	21.9	46.5	68.4	74	5.6	PK
	V	7236	2.6	46.5	49.1	54	4.9	AV
	H	24000	11.7	38.9	50.6	54	3.4	PK
6	V	2437	83.9	31.2	115.1	Fundamental	/	PK
	V	3200	9.7	31.1	40.8	54(note3)	13.2	PK
	V	4876	19.4	32.8	52.2	54(note3)	1.8	PK
	V	7311	20.3	46.8	67.1	74	6.9	PK
	V	7311	4.7	46.1	50.8	54	3.2	AV
	H	24000	11.7	38.9	50.6	54	3.4	PK
11	V	2462.3	83.8	30.9	114.7	Fundamental	/	PK
	V	3200	10.1	31.1	41.2	54(note3)	12.8	PK
	V	2483.5	33.5	30.2	63.7	74	10.3	PK
	V	2483.5	15.0	30.2	45.2	54	8.8	AV
	V	4927	18.4	32.5	50.9	54(note3)	3.1	PK
	V	7386	22.5	46.3	68.8	74	5.2	PK
	V	7386	3.4	46.3	49.7	54	4.3	AV
	H	24000	11.7	38.9	50.6	54	3.4	PK

Note: 1. Measure Level = Reading Level + Factor.

2. The test results which are attenuated more than 20 dB below the permissible value limit (the test frequency range: 9kHz~30MHz, 18GHz~25GHz), therefore no data appear in the report.

3. This limit applies for using average detector, if the test result on peak is lower than average limit, then average measurement needn't be performed.

Remark: RBW 1MHz VBW 3MHz peak detector for PK value, RMS detector for AV value

802.11n(20MHz)

CH	Antenna	Frequency (MHz)	Reading Level (dBuV/m)	Factor (dB)	Measure Level (dBuV/m)	Limit (dBuV/m)	Margin (dB)	Detector
1	V	2411.9	83.6	30.8	114.4	Fundamental	/	PK
	V	3200	13.4	31.1	44.5	54(note3)	9.5	PK
	V	2390	36.5	32.2	68.7	74	5.3	PK
	V	2390	18.7	32.2	50.9	54	3.1	AV
	V	2400	39.1	32.1	71.2	74	2.8	PK
	V	2400	20.8	32.1	52.9	54	1.1	AV
	V	4824	9.5	42.6	52.1	54(note3)	1.9	PK
	V	7236	22.1	46.5	68.6	74	5.4	PK
	V	7236	3.7	46.5	50.2	54	3.8	AV
	H	24000	11.7	38.9	50.6	54	3.4	PK
6	V	2437	82.9	31.2	114.1	Fundamental	/	PK
	V	3200	9.7	31.1	40.8	54(note3)	13.2	PK
	V	4876	17.6	32.8	50.4	54(note3)	3.6	PK
	V	7311	21.4	46.8	68.2	74	5.8	PK
	V	7311	2.6	46.1	48.7	54	5.3	AV
	H	24000	11.7	38.9	50.6	54	3.4	PK
11	V	2462.3	83.8	30.9	114.7	Fundamental	/	PK
	V	3200	10.1	31.1	41.2	54(note3)	12.8	PK
	V	2483.5	33.6	30.2	63.8	74	10.2	PK
	V	2483.5	14.9	30.2	45.1	54	8.9	AV
	V	4927	19.2	32.5	51.7	54(note3)	2.3	PK
	V	7386	24.3	46.3	70.6	74	3.4	PK
	V	7386	4.9	46.3	51.2	54	2.8	AV
	H	24000	11.7	38.9	50.6	54	3.4	PK

Note: 1. Measure Level = Reading Level + Factor.

2. The test results which are attenuated more than 20 dB below the permissible value limit (the test frequency range: 9kHz~30MHz, 18GHz~25GHz), therefore no data appear in the report.

3. This limit applies for using average detector, if the test result on peak is lower than average limit, then average measurement needn't be performed.

Remark: RBW 1MHz VBW 3MHz peak detector for PK value, RMS detector for AV value

802.11n(40MHz)

CH	Antenna	Frequency (MHz)	Reading Level (dBuV/m)	Factor (dB)	Measure Level (dBuV/m)	Limit (dBuV/m)	Margin (dB)	Detector
3	V	2422	83.4	30.8	114.2	Fundamental	/	PK
	V	3200	12.0	31.1	43.1	54(note3)	10.9	PK
	V	2390	37.2	32.2	69.4	74	4.6	PK
	V	2390	18.3	32.2	50.5	54	3.5	AV
	V	2400	38.6	32.1	70.7	74	3.3	PK
	V	2400	19.1	32.1	51.2	54	2.8	AV
	V	4844	9.3	42.9	52.2	54(note3)	1.8	PK
	V	7266	22.7	46.8	69.5	74	4.5	PK
	V	7266	4.0	46.8	50.8	54	3.2	AV
	H	24000	11.7	38.9	50.6	54	3.4	PK
6	V	2437	82.7	31.2	113.9	Fundamental	/	PK
	V	3200	9.5	31.1	40.6	54(note3)	13.4	PK
	V	4876	18.9	32.8	51.7	54(note3)	2.3	PK
	V	7311	23.6	46.8	70.4	74	3.6	PK
	V	7311	5.7	46.1	51.8	54	2.2	AV
	H	24000	11.7	38.9	50.6	54	3.4	PK
9	V	2452	83.2	30.9	114.1	Fundamental	/	PK
	V	3200	10.1	31.1	41.2	54(note3)	12.8	PK
	V	2483.5	32.4	30.2	62.6	74	11.4	PK
	V	2483.5	13.0	30.2	43.2	54	10.8	AV
	V	4967	19.3	32.5	51.8	54(note3)	2.2	PK
	V	7356	22.3	46.1	68.4	74	5.6	PK
	V	7356	4.4	46.1	50.5	54	3.5	AV
	H	24000	11.7	38.9	50.6	54	3.4	PK

Note: 1. Measure Level = Reading Level + Factor.

2. The test results which are attenuated more than 20 dB below the permissible value limit (the test frequency range: 9kHz~30MHz, 18GHz~25GHz), therefore no data appear in the report.

3. This limit applies for using average detector, if the test result on peak is lower than average limit, then average measurement needn't be performed.

Remark: RBW 1MHz VBW 3MHz peak detector for PK value, RMS detector for AV value

4.3. 6dB Bandwidth Measurement

TEST CONFIGURATION

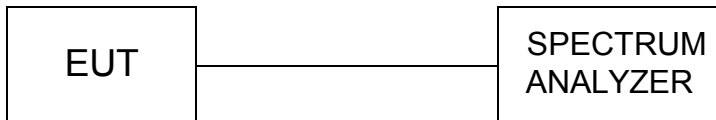

TEST PROCEDURE

1. The testing follows FCC KDB Publication No. 558074 D01 v03r03 (Measurement Guidelines of DTS).
2. The RF output of EUT was connected to the spectrum analyzer by a low loss cable.
3. Make the measurement with the spectrum analyzer's resolution bandwidth (RBW) = 100 kHz. In order to make an accurate measurement, set the span greater than RBW. The 6 dB bandwidth must be greater than 500 kHz.
4. The marker-delta reading at this point is the 6 dB bandwidth of the emission. Peak detector is used

LIMIT

For digital modulation systems, the minimum 6 dB bandwidth shall be at least 500 kHz.

TEST RESULTS

Product	:	Camera
Test Item	:	6dB Occupied Bandwidth
Test Mode	:	Mode 1: Transmit by 802.11b

Channel No.	Frequency (MHz)	Occupied Bandwidth (kHz)	Limit (kHz)	Result
01	2412	9072	500	Pass
06	2437	8325	500	Pass
11	2462	8333	500	Pass

Channel 01 (2412MHz)

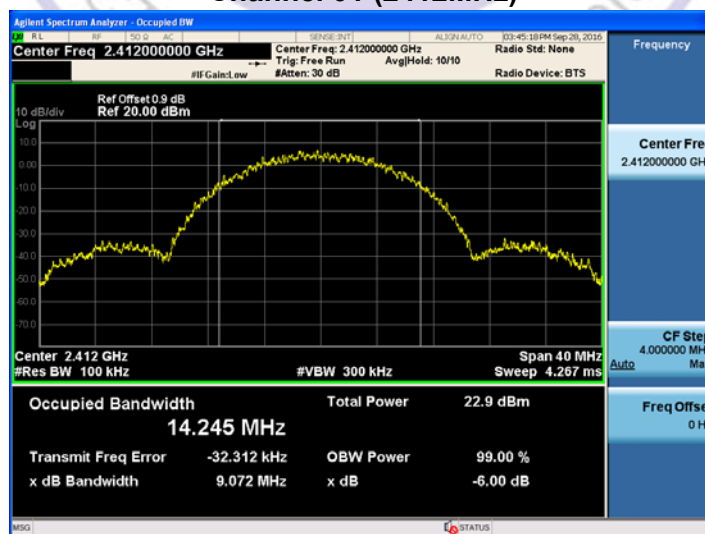

Channel 06 (2437MHz)

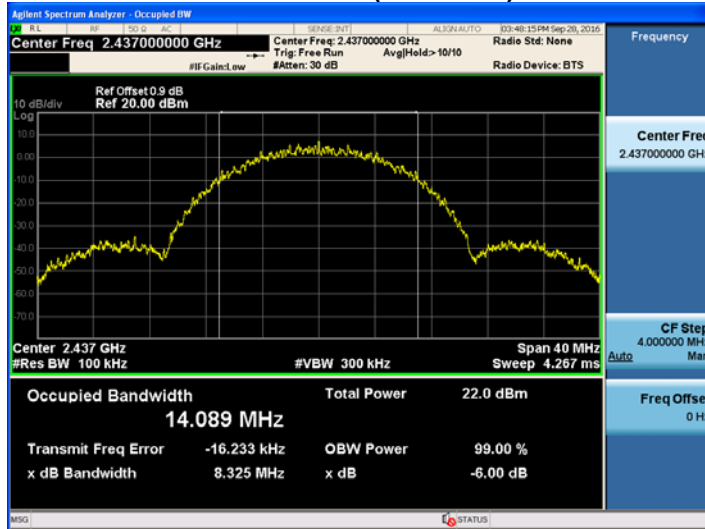

Channel 11 (2462MHz)

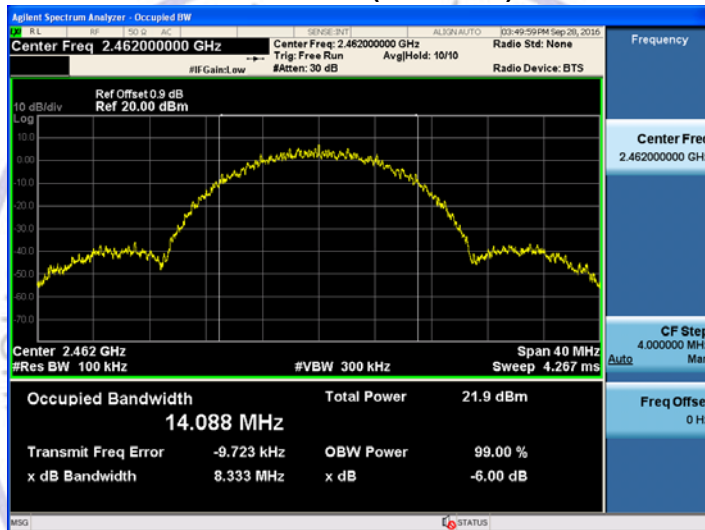

Product	:	Camera
Test Item	:	6dB Occupied Bandwidth
Test Mode	:	Mode 2: Transmit by 802.11g

Channel No.	Frequency (MHz)	Occupied Bandwidth (kHz)	Limit (kHz)	Result
01	2412	15110	500	Pass
06	2437	15100	500	Pass
11	2462	15110	500	Pass

Channel 01 (2412MHz)

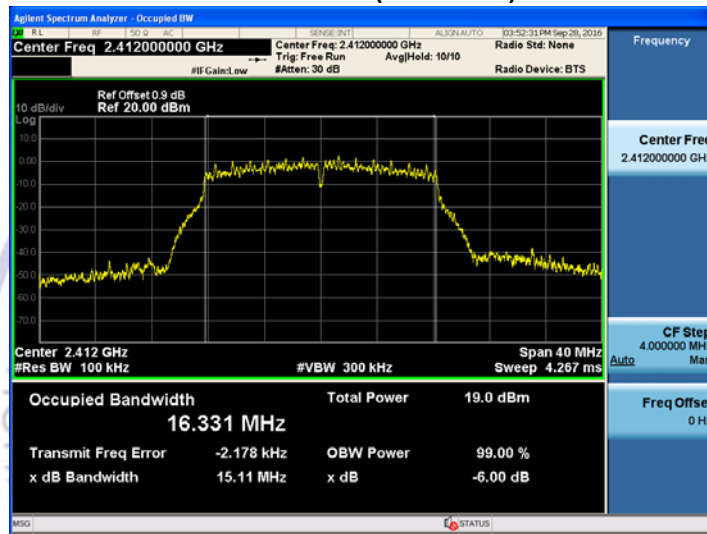

Channel 06 (2437MHz)

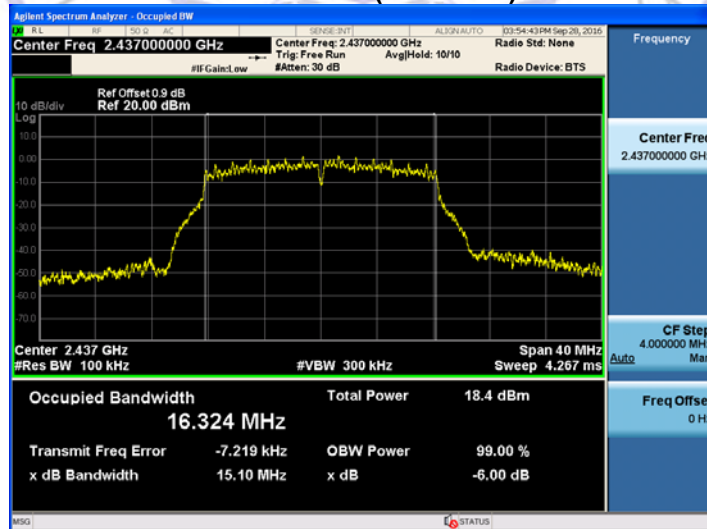

Channel 11 (2462MHz)

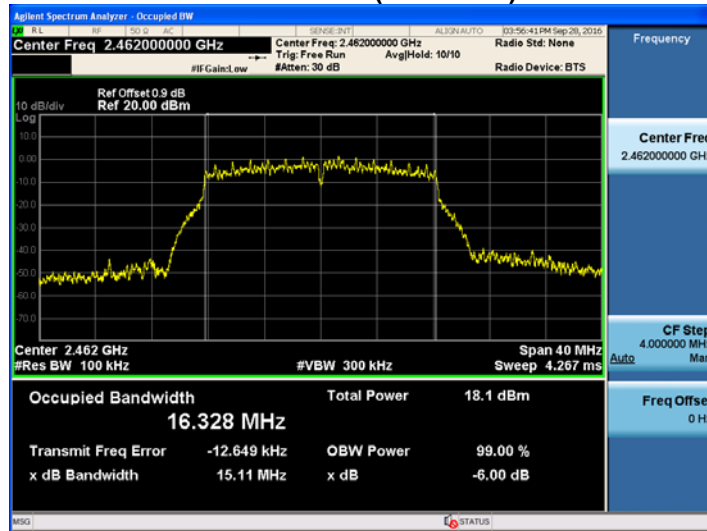

Product	:	Camera
Test Item	:	6dB Occupied Bandwidth
Test Mode	:	Mode 3: Transmit by 802.11n (20MHz)

Channel No.	Frequency (MHz)	Occupied Bandwidth (kHz)	Limit (kHz)	Result
01	2412	15100	500	Pass
06	2437	15110	500	Pass
11	2462	15110	500	Pass

Channel 01 (2412MHz)

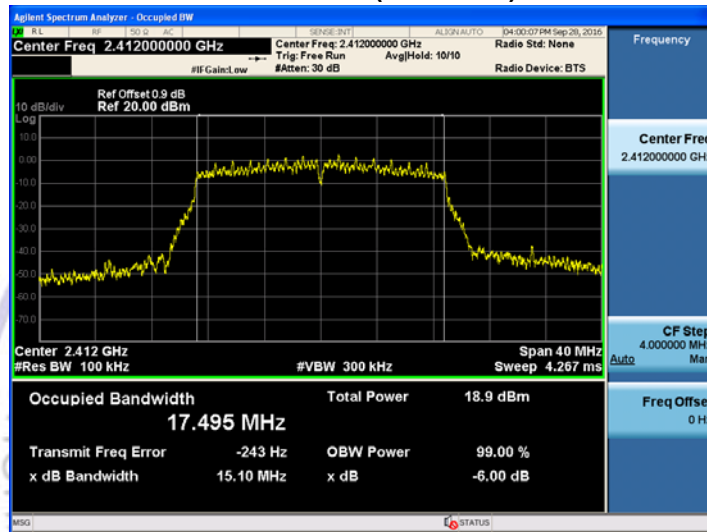

Channel 06 (2437MHz)

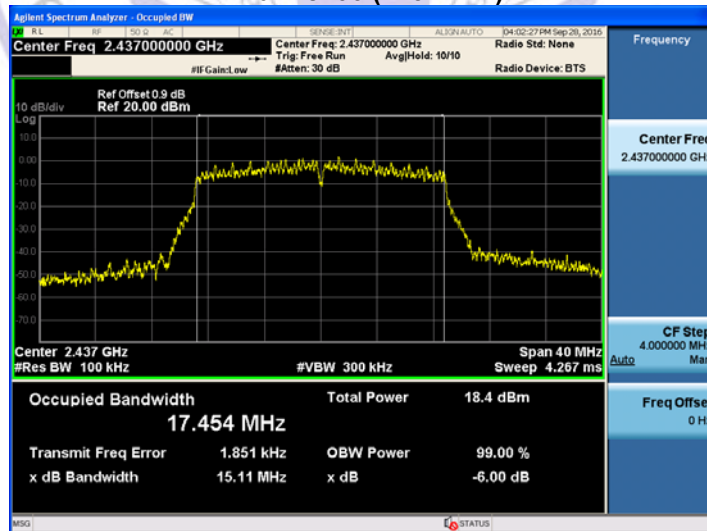

Channel 11 (2462MHz)

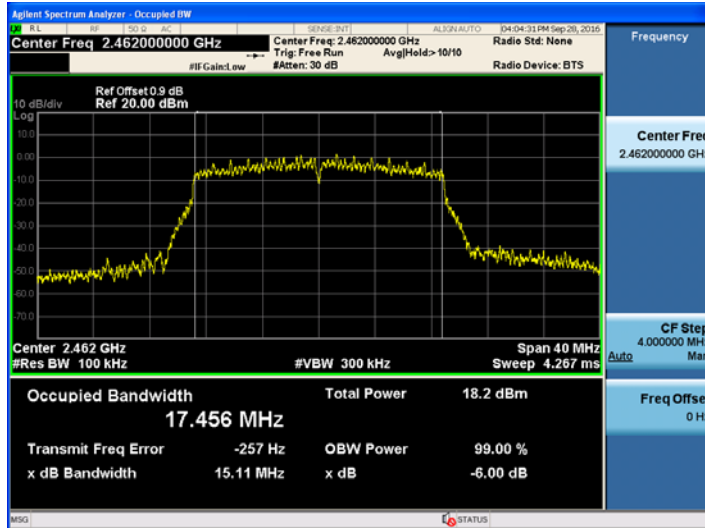

Product	:	Camera
Test Item	:	6dB Occupied Bandwidth
Test Mode	:	Mode 3: Transmit by 802.11n (40MHz)

Channel No.	Frequency (MHz)	Occupied Bandwidth (kHz)	Limit (kHz)	Result
03	2422	35070	500	Pass
06	2437	35100	500	Pass
09	2452	35100	500	Pass

Channel 03 (2422MHz)

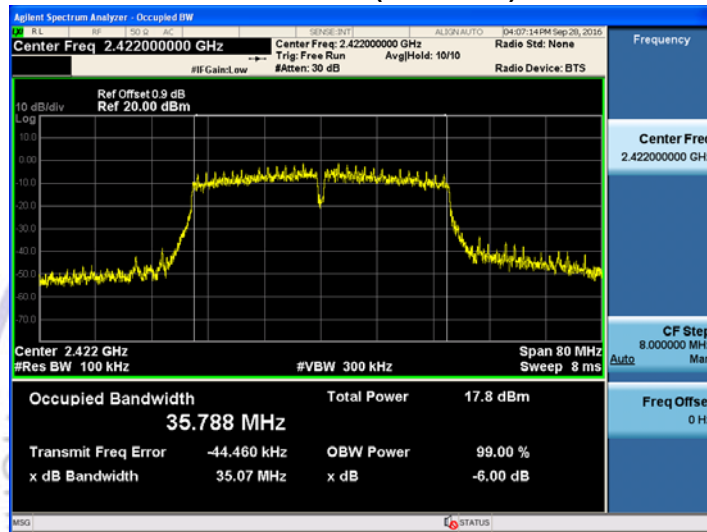

Channel 06 (2437MHz)

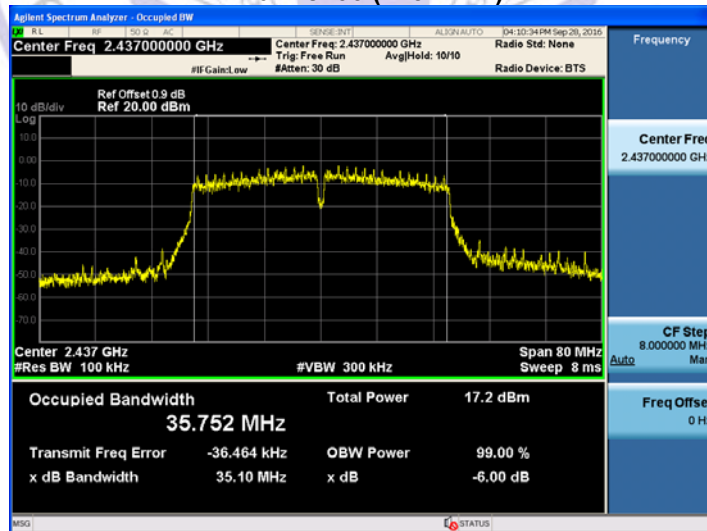

Channel 09 (2452MHz)

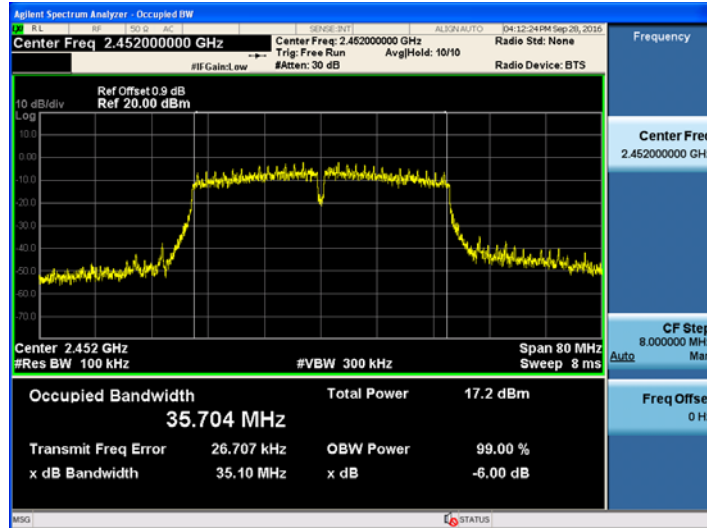

4.4. Maximum Peak Output Power

TEST CONFIGURATION

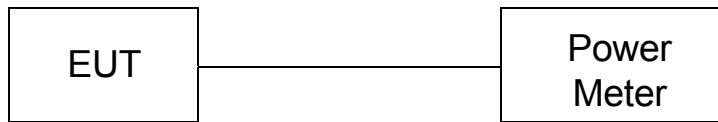

TEST PROCEDURE

According to C63.10 -2013 and KDB558074 D01 v03r03, The EUT was directly connected to the power meter / spectrum analyzer and antenna output port as show in the block diagram as TEST CONFIGURATION shows.

Use the wideband power meter to test peak power and record the result.

LIMIT

The Peak Output Power Measurement limits are 30dBm.

TEST RESULTS

Product	:	Camera
Test Item	:	Power Output
Test Mode	:	Mode 1: Transmit by 802.11b

Channel No.	Frequency (MHz)	Measurement Power Output (dBm)	Limit (dBm)	Result
1	2412	21.84	30.00	Pass
6	2437	20.73	30.00	Pass
11	2462	20.61	30.00	Pass

Product	:	Camera
Test Item	:	Power Output
Test Mode	:	Mode 2: Transmit by 802.11g

Channel No.	Frequency (MHz)	Measurement Power Output (dBm)	Limit (dBm)	Result
1	2412	20.93	30.00	Pass
6	2437	20.34	30.00	Pass
11	2462	20.19	30.00	Pass

Product	:	Camera
Test Item	:	Power Output
Test Mode	:	Mode 3: Transmit by 802.11n(20MHz)

Channel No.	Frequency (MHz)	Measurement Power Output (dBm)	Limit (dBm)	Result
1	2412	20.69	30.00	Pass
6	2437	19.97	30.00	Pass
11	2462	19.76	30.00	Pass

Product	:	Camera
Test Item	:	Power Output
Test Mode	:	Mode 3: Transmit by 802.11n(40MHz)

Channel No.	Frequency (MHz)	Measurement Power Output (dBm)	Limit (dBm)	Result
3	2422	19.54	30.00	Pass
6	2437	18.89	30.00	Pass
9	2452	18.87	30.00	Pass

Note: The test results including the cable lose.

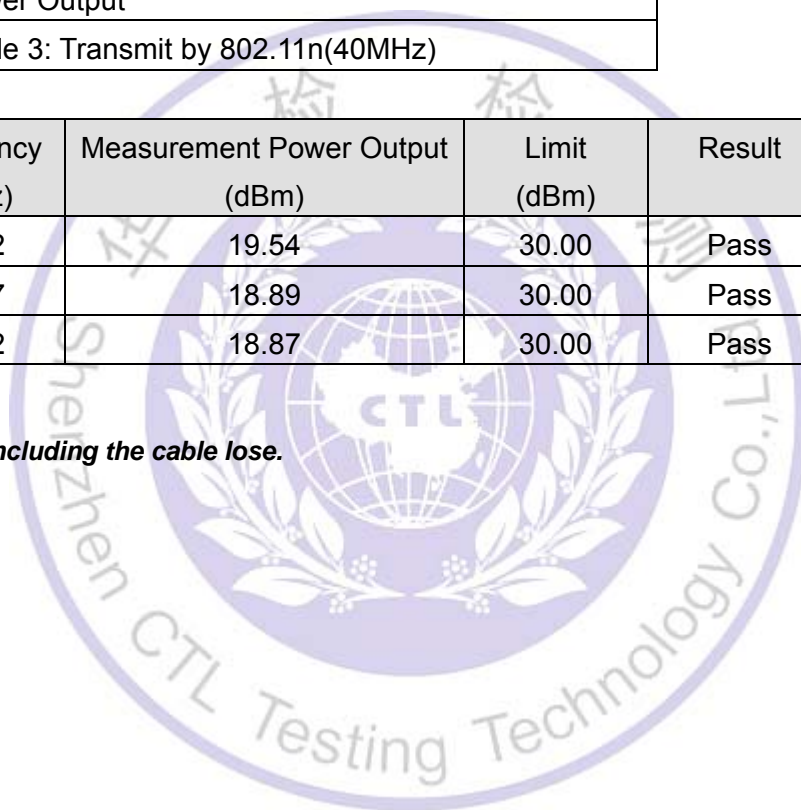

4.5. Power Spectral Density Measurement

TEST CONFIGURATION

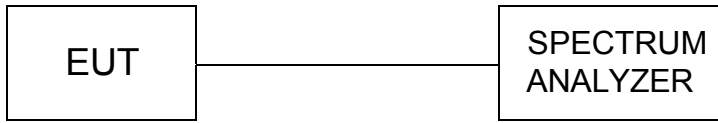

TEST PROCEDURE

The EUT was tested according to KDB558074 D01 v03r03 for compliance to FCC 47CFR 15.247 and requirements. Set RBW= 3 kHz, VBW ≥ 10KHz, SPAN to 1.5 times greater than the EBW,.

LIMIT

For digitally modulated systems, the power spectral density conducted from the intentional radiator to the antenna shall not be greater than 8 dBm in any 3 kHz band during any time interval of continuous transmission.

TEST RESULTS

Product	:	Camera
Test Item	:	Power Spectral Density
Test Mode	:	Mode 1: Transmit by 802.11b

Channel No.	Frequency (MHz)	Measurement PPSD (dBm/3KHz)	Limit (dBm/3KHz)	Result
01	2412	-6.795	8	Pass
06	2437	-8.273	8	Pass
11	2462	-8.555	8	Pass

Channel 01 (2412MHz)

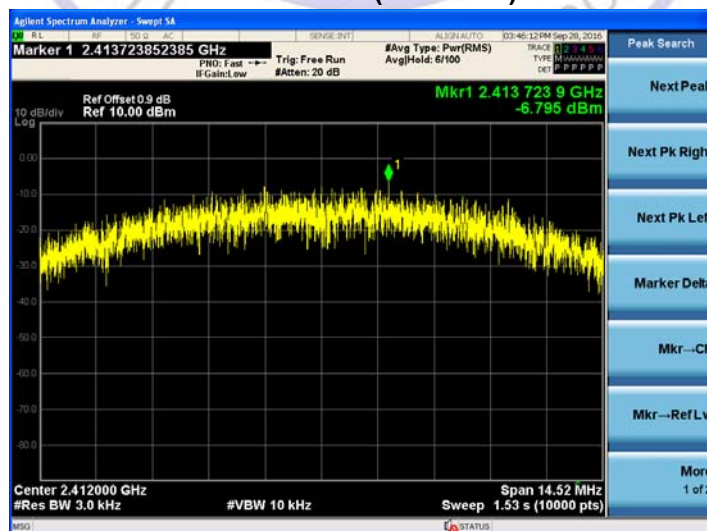

Channel 06 (2437MHz)

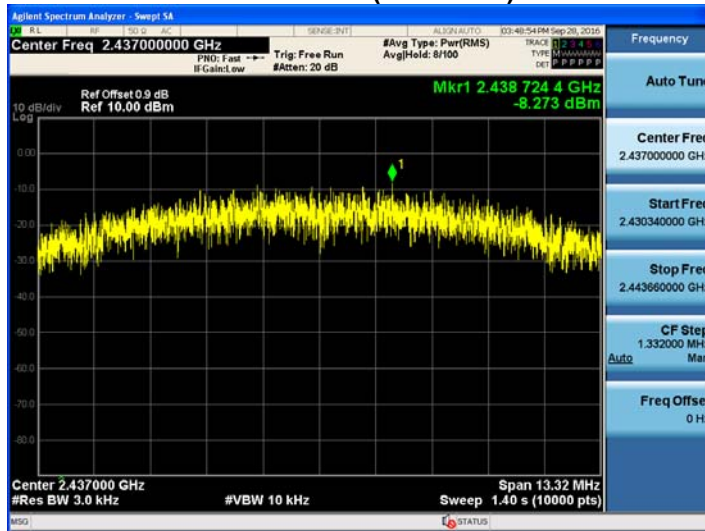

Channel 11 (2462MHz)

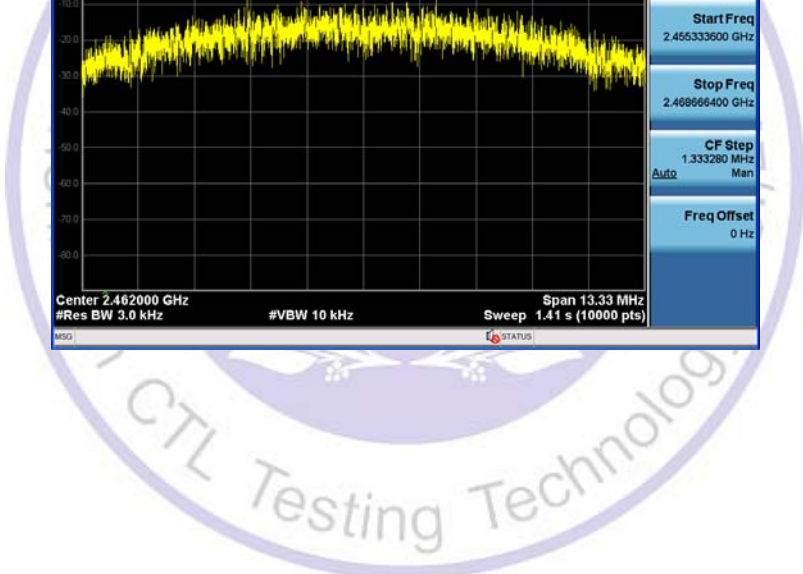
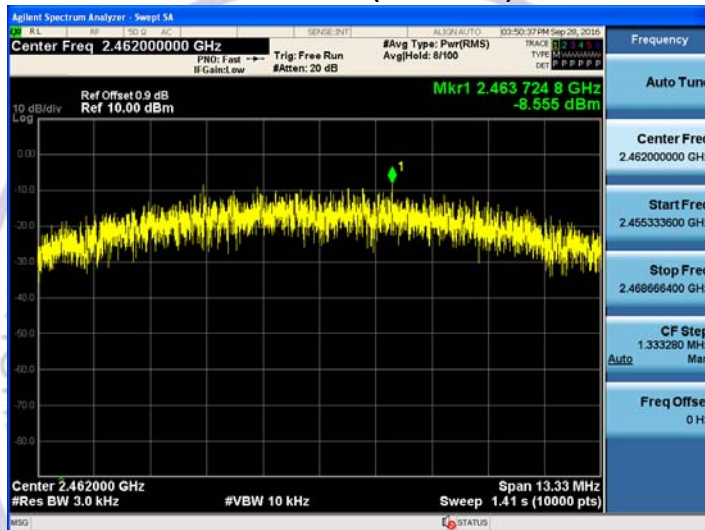

Product	:	Camera
Test Item	:	Power Spectral Density
Test Mode	:	Mode 2: Transmit by 802.11g

Channel No.	Frequency (MHz)	Measurement PPSD (dBm/3KHz)	Limit (dBm/3KHz)	Result
01	2412	-14.077	8	Pass
06	2437	-14.961	8	Pass
11	2462	-15.212	8	Pass

Channel 01 (2412MHz)

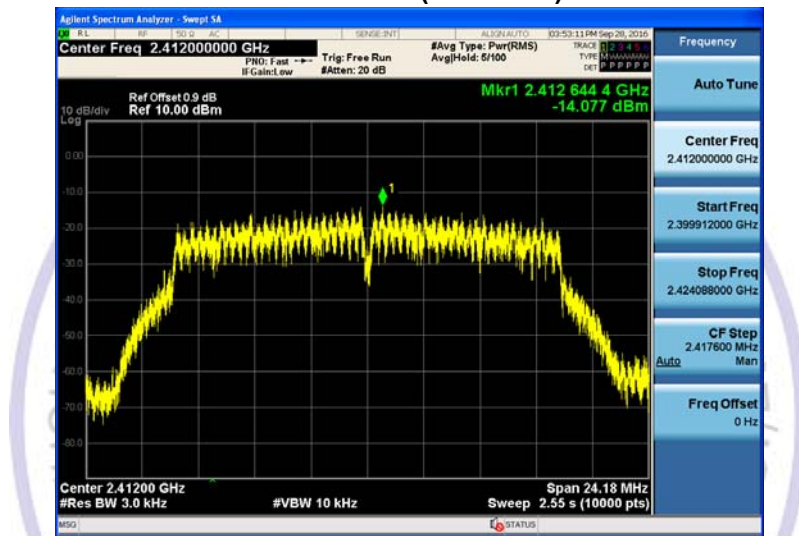

Channel 06 (2437MHz)

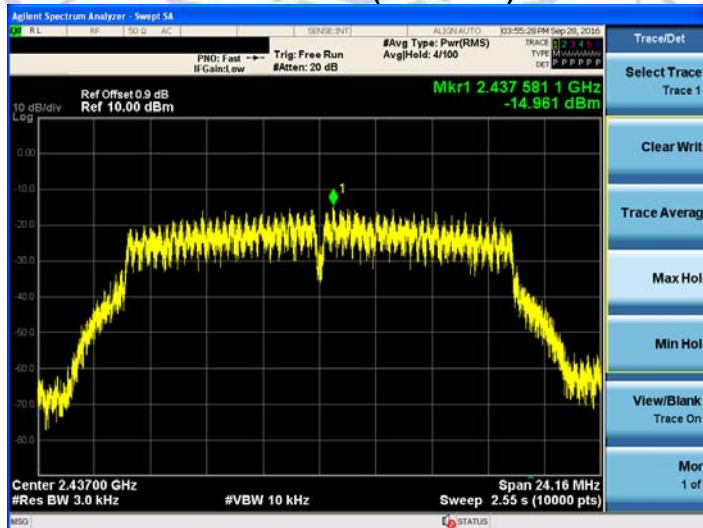

Channel 11 (2462MHz)

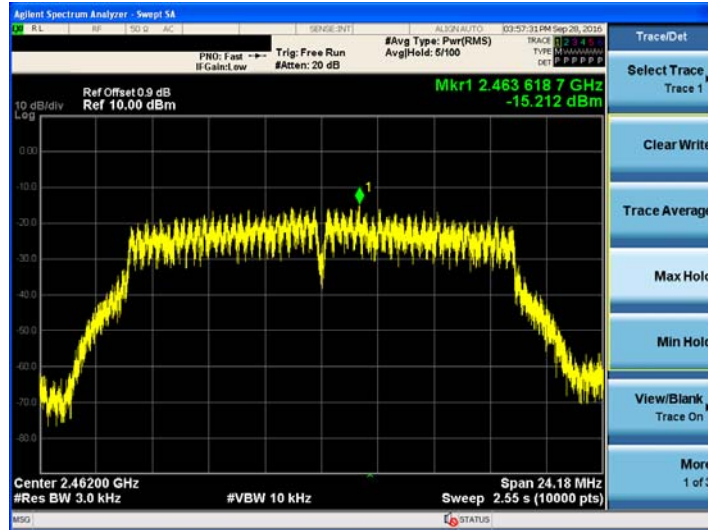

Product	:	Camera
Test Item	:	Power Spectral Density
Test Mode	:	Mode 3: Transmit by 802.11n (20MHz)

Channel No.	Frequency (MHz)	Measurement PPSD (dBm/3KHz)	Limit (dBm/3KHz)	Result
01	2412	-14.330	8	Pass
06	2437	-13.940	8	Pass
11	2462	-13.458	8	Pass

Channel 01 (2412MHz)

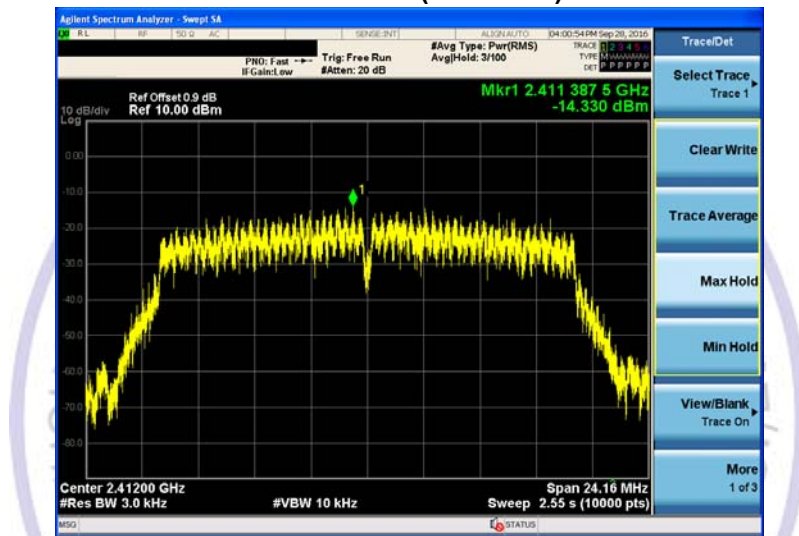

Channel 06 (2437MHz)

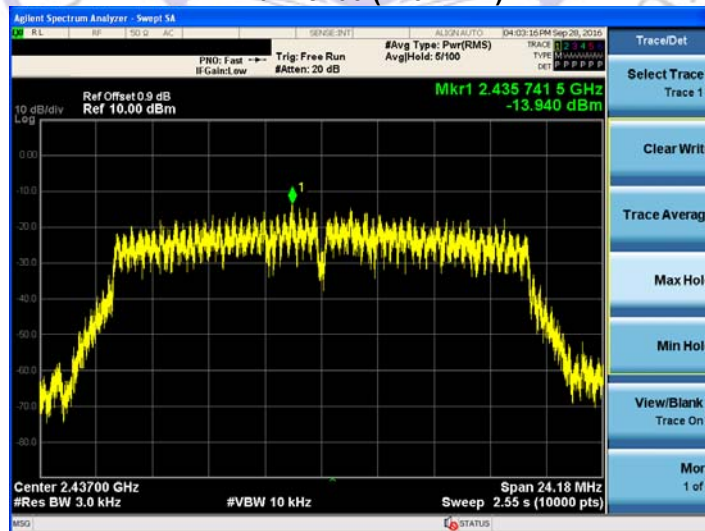

Channel 11 (2462MHz)

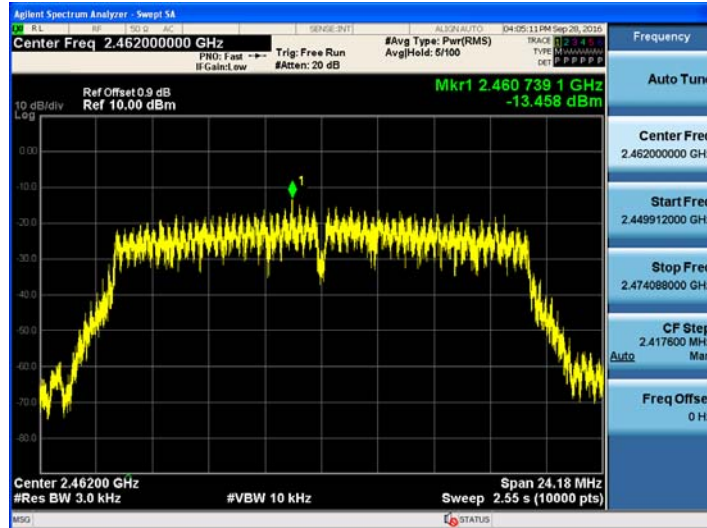

Product	:	Camera
Test Item	:	Power Spectral Density
Test Mode	:	Mode 3: Transmit by 802.11n (40MHz)

Channel No.	Frequency (MHz)	Measurement PPSD (dBm/3KHz)	Limit (dBm/3KHz)	Result
03	2422	-18.368	8	Pass
06	2437	-19.293	8	Pass
09	2452	-18.812	8	Pass

Channel 03 (2422MHz)

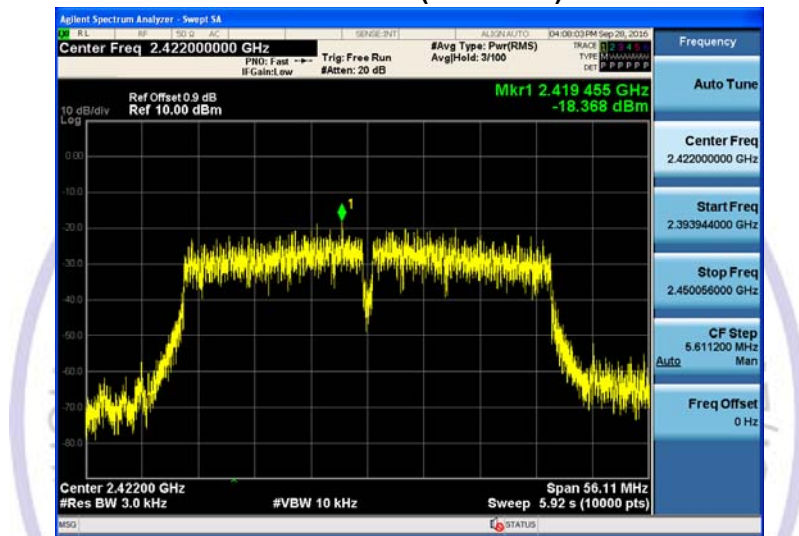

Channel 06 (2437MHz)

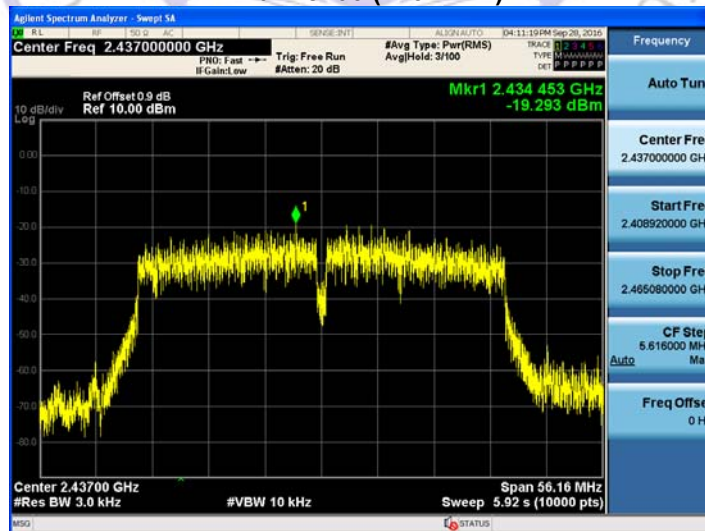

4.6. Spurious RF Conducted Emission and bandedge Test

TEST CONFIGURATION

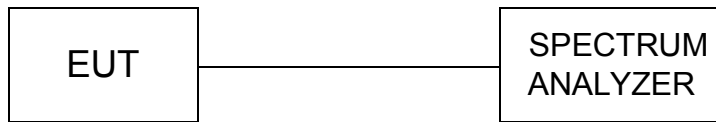

TEST PROCEDURE

The EUT was tested according to KDB558074 D01 v03r03 for compliance to FCC 47CFR 15.247 requirements.

The Spurious RF conducted emissions compliance of RF radiated emission should be measured by following the guidance in ANSI C63.10-2013 with respect to maximizing the emission by rotating the EUT, measuring the emission while the EUT is situated in three orthogonal planes (if appropriate), adjusting the measurement antenna height and polarization etc. Set RBW=100kHz and VBM= 300kHz to measure the peak field strength , and measure frequency range from 30MHz to 26.5GHz.

LIMIT

In any 100 kHz bandwidth outside the frequency band in which the spread spectrum or digitally modulated intentional radiator is operating, the radio frequency power that is produced by the intentional radiator shall be at least 20 dB below that in the 100 kHz bandwidth within the band that contains the highest level of the desired power, based on either an RF conducted or a radiated measurement, provided the transmitter demonstrates compliance with the peak conducted power limits.

TEST RESULTS

Product	:	Camera
Test Item	:	RF Antenna Conducted Spurious
Test Mode	:	Mode 1: Transmit by 802.11b

Channel 01 (2412MHz)

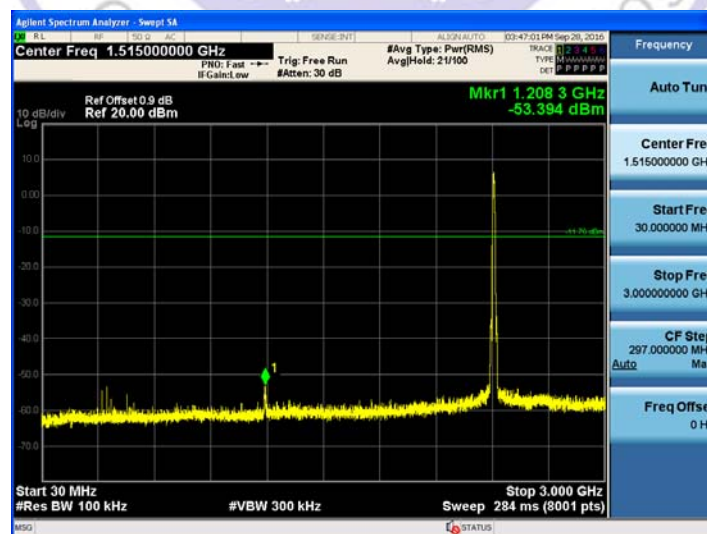

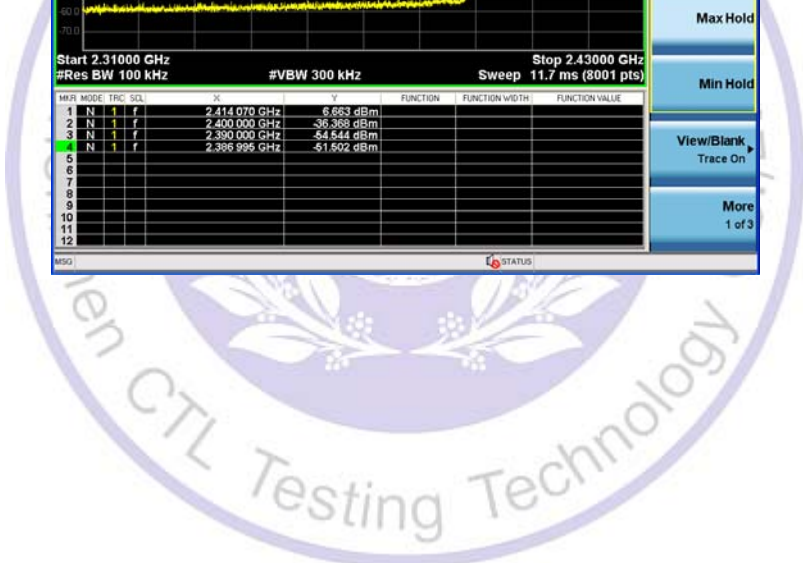
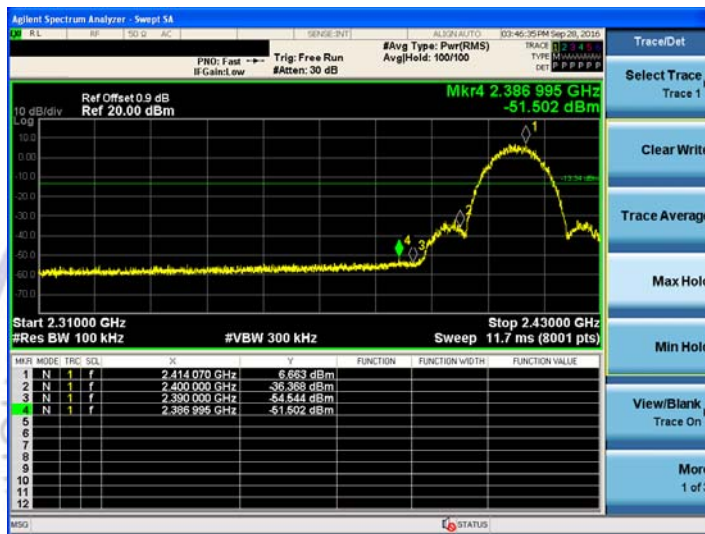
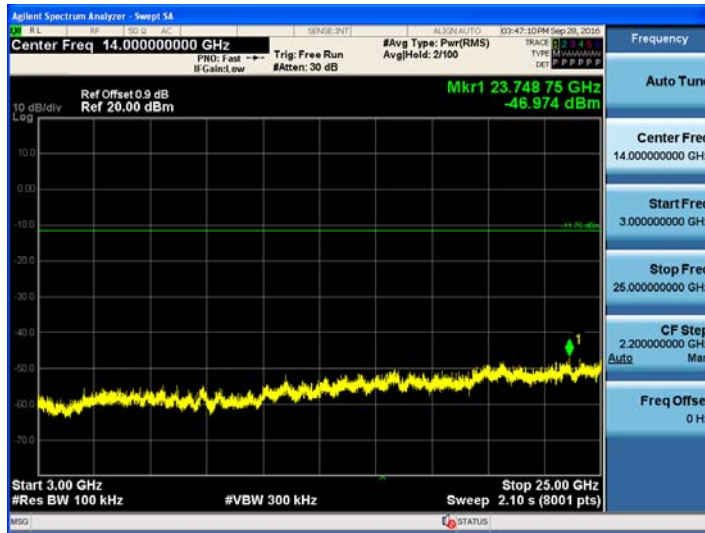

Channel 06 (2437MHz)

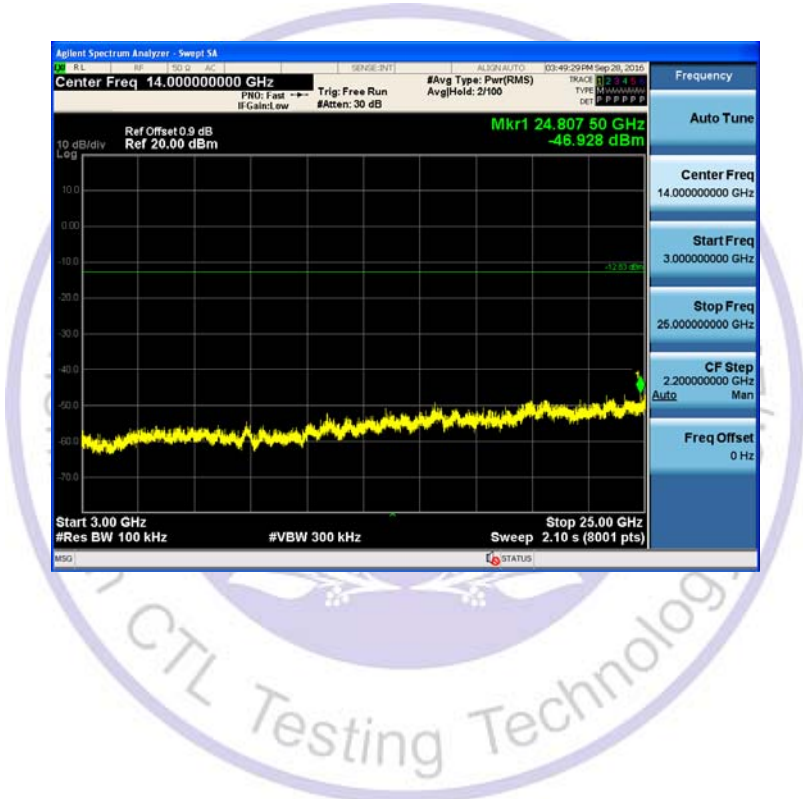
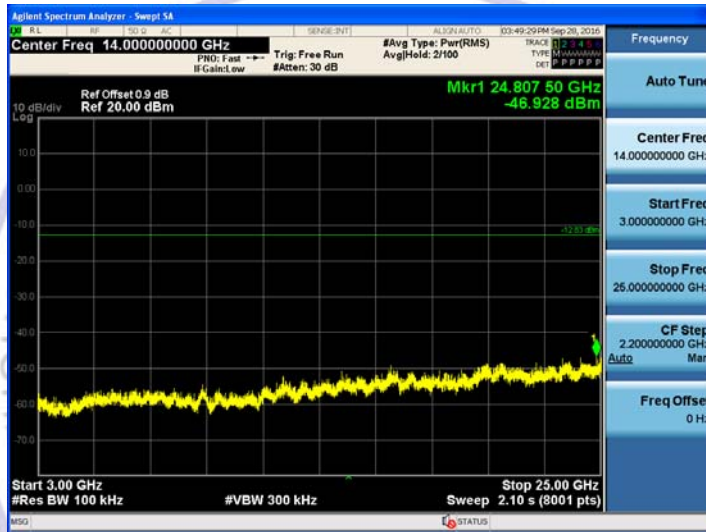
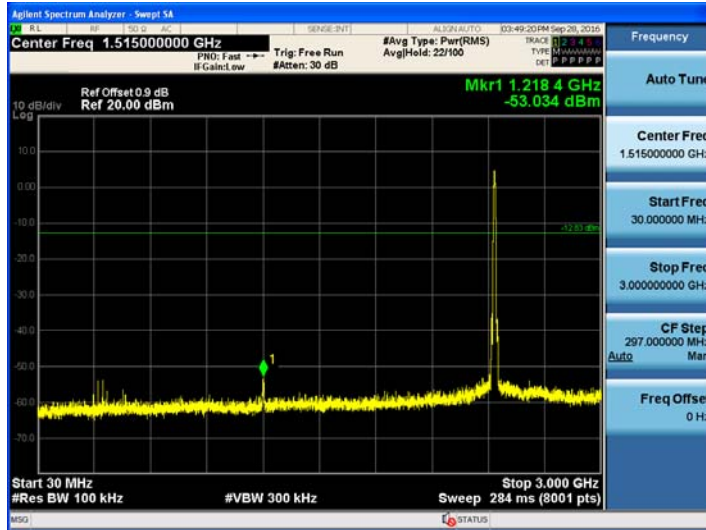

Channel 11 (2462MHz)

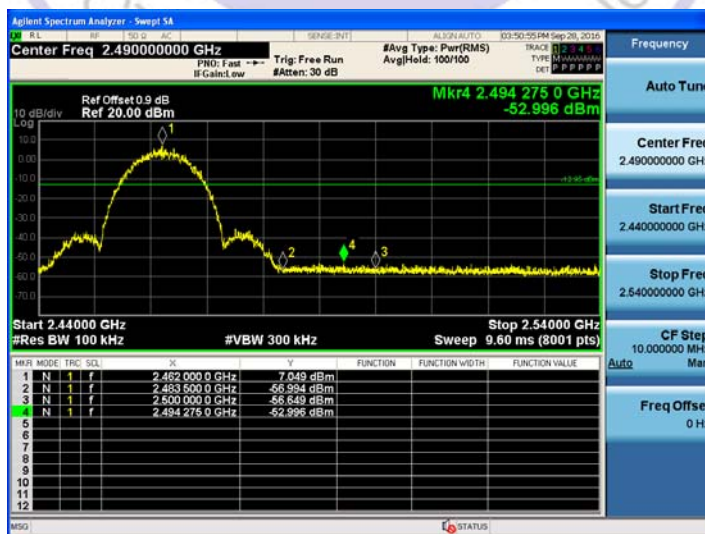
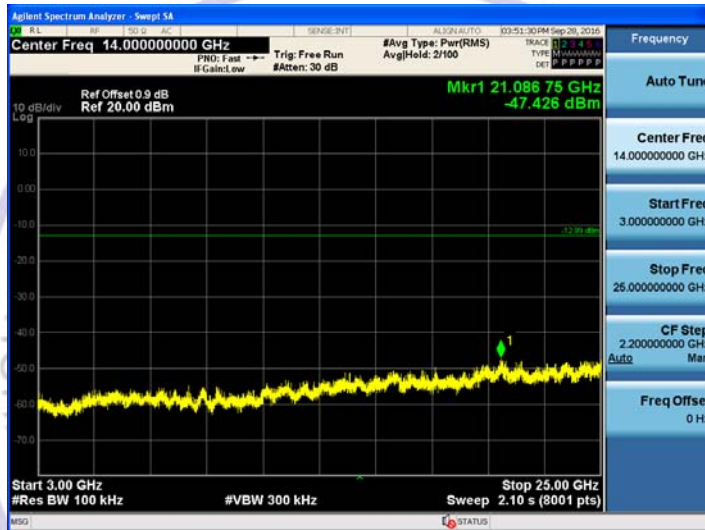
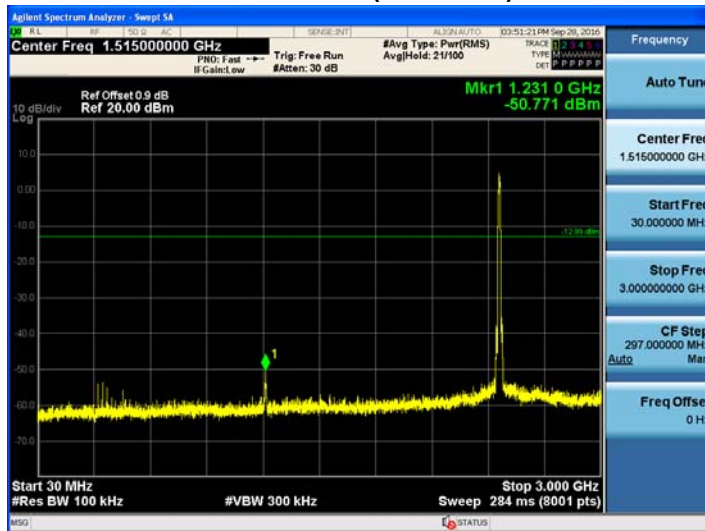

Product	:	Camera
Test Item	:	RF Antenna Conducted Spurious
Test Mode	:	Mode 2: Transmit by 802.11g

Channel 01 (2412MHz)

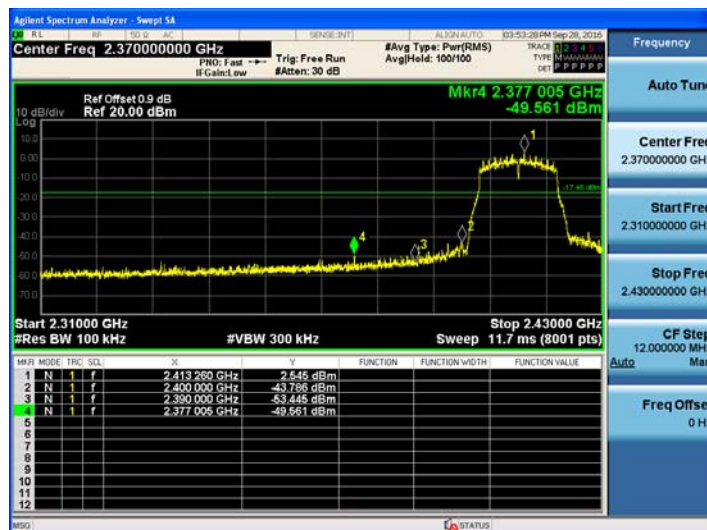
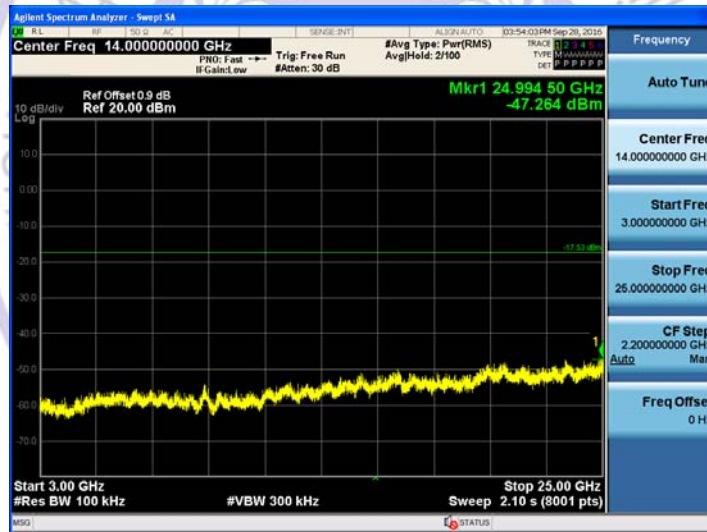
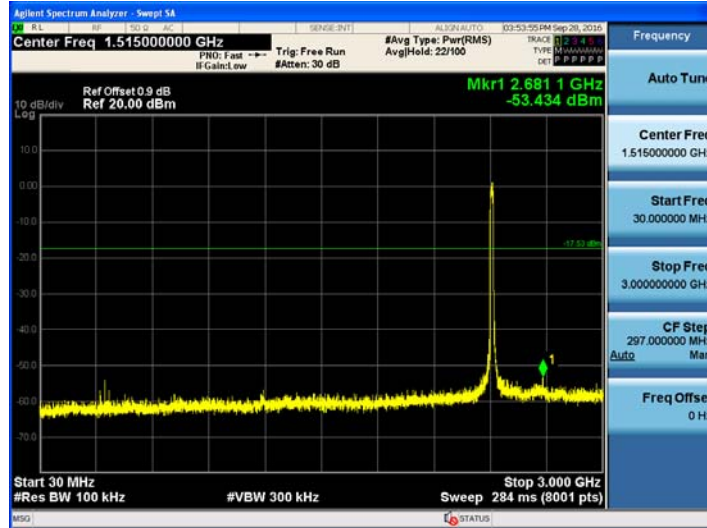

Channel 06 (2437MHz)

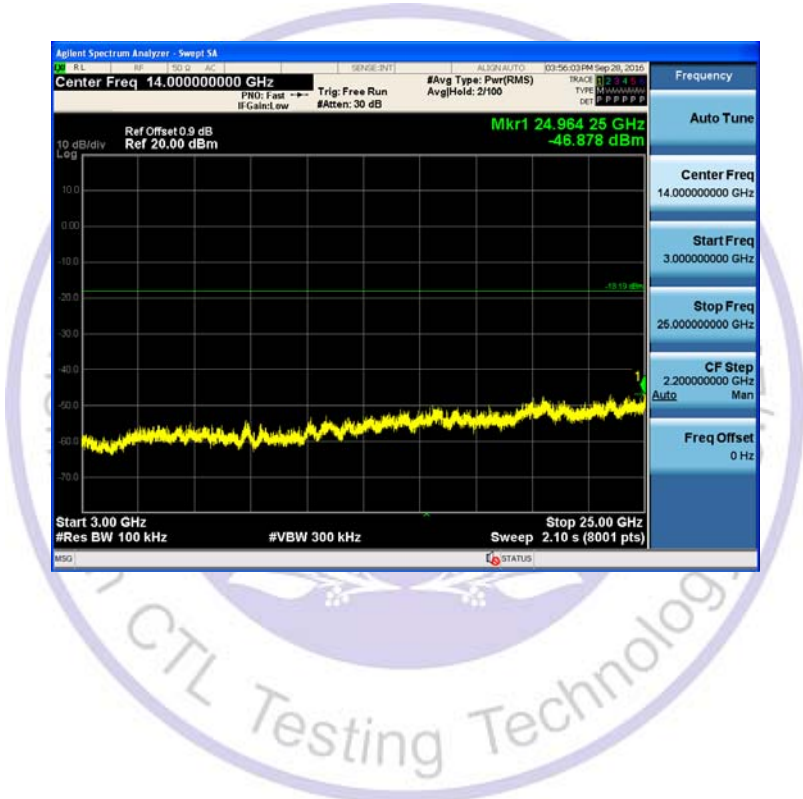
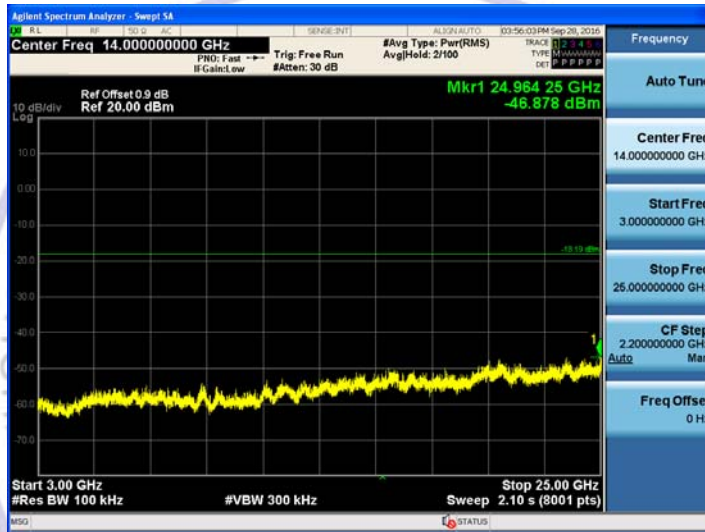
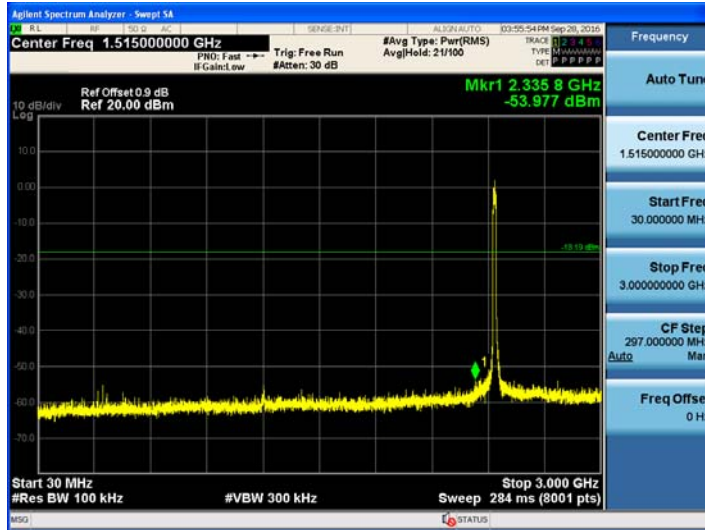

Channel 11 (2462MHz)

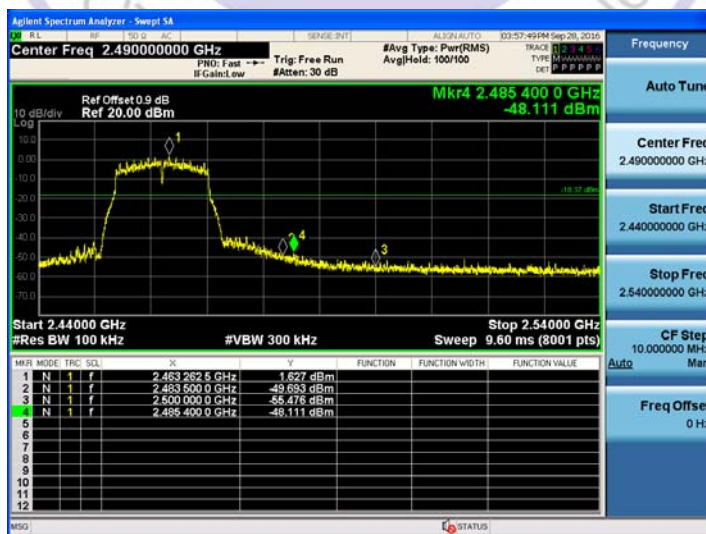
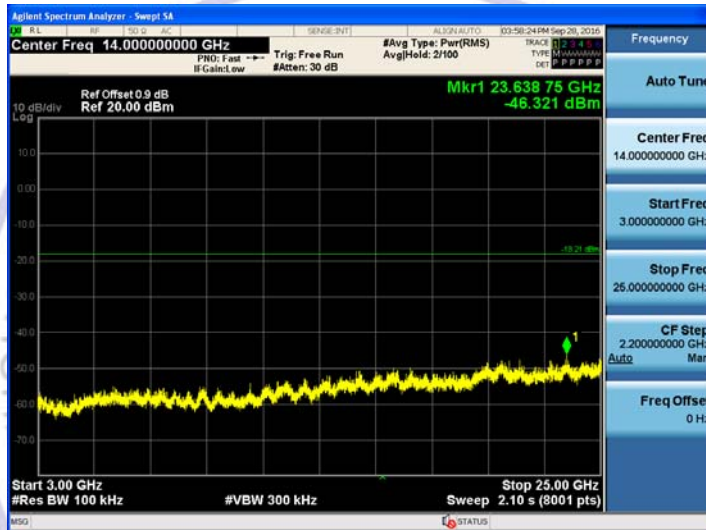
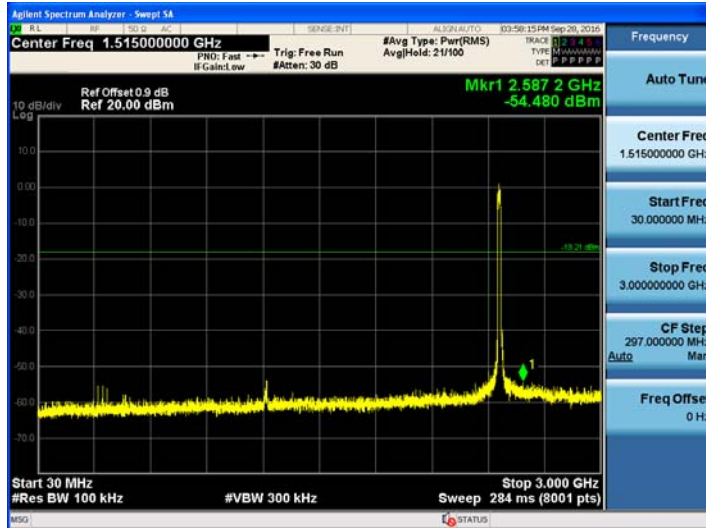

Product	:	Camera
Test Item	:	RF Antenna Conducted Spurious
Test Mode	:	Mode 3: Transmit by 802.11n (20MHz)

Channel 01 (2412MHz)

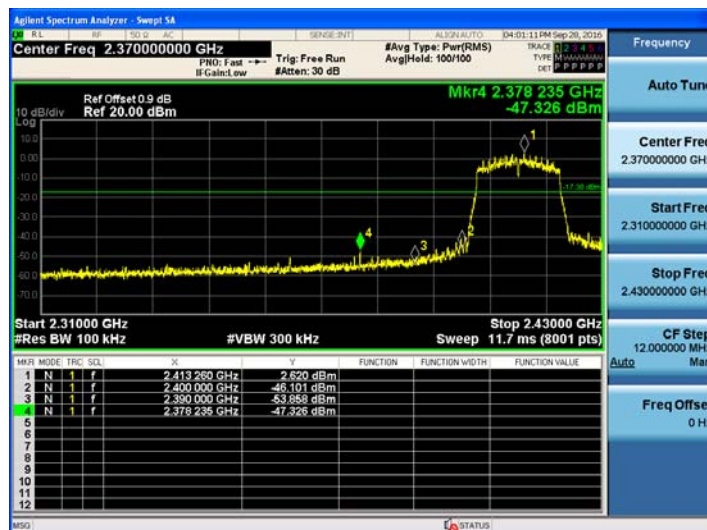
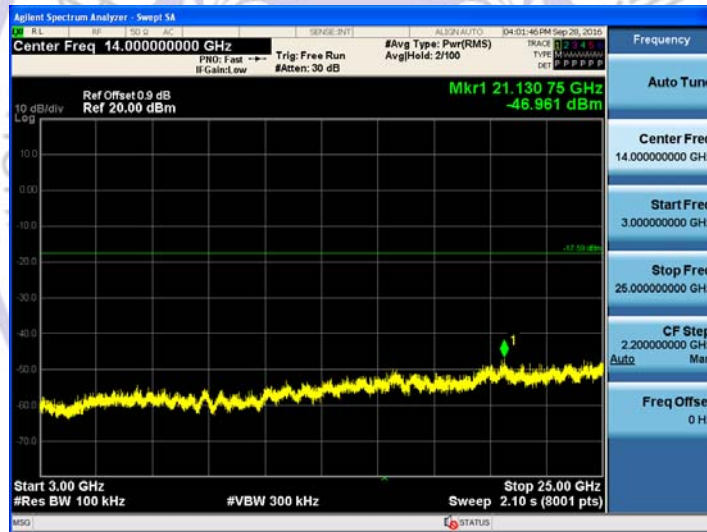
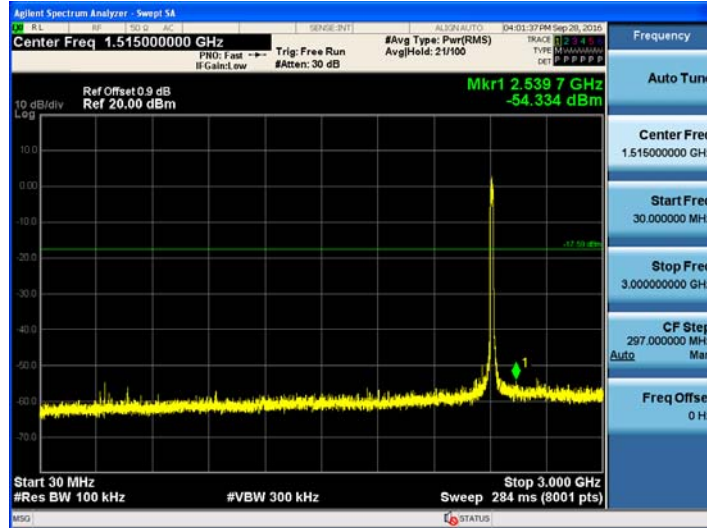

Channel 06 (2437MHz)

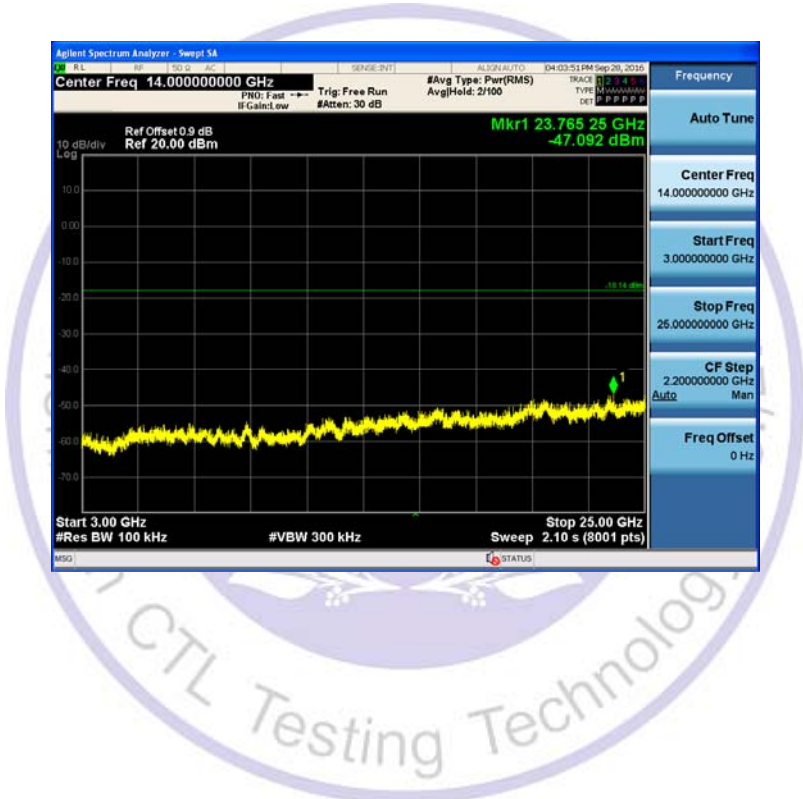
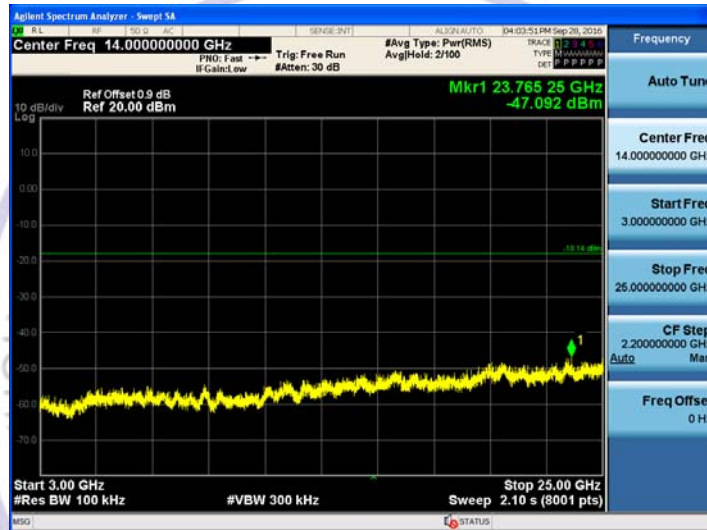
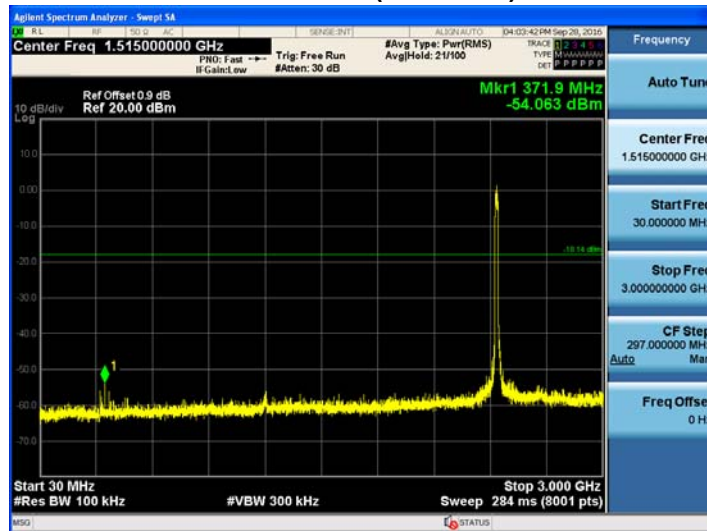

Channel 11 (2462MHz)

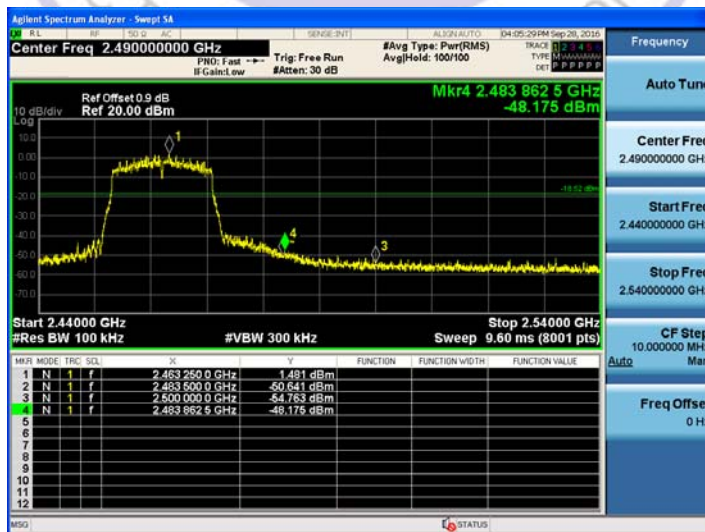
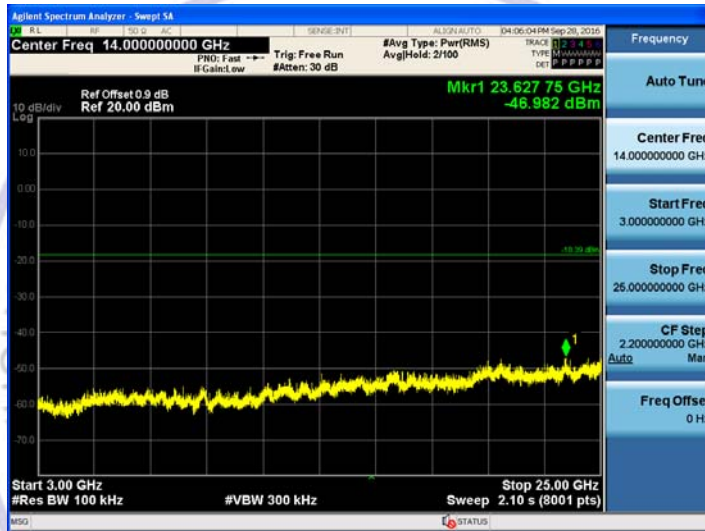
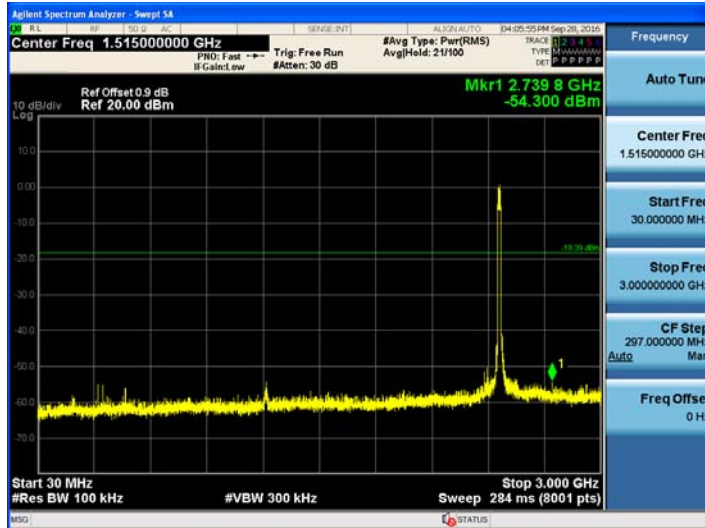

Product	:	Camera
Test Item	:	RF Antenna Conducted Spurious
Test Mode	:	Mode 3: Transmit by 802.11n (40MHz)

Channel 03 (2422MHz)

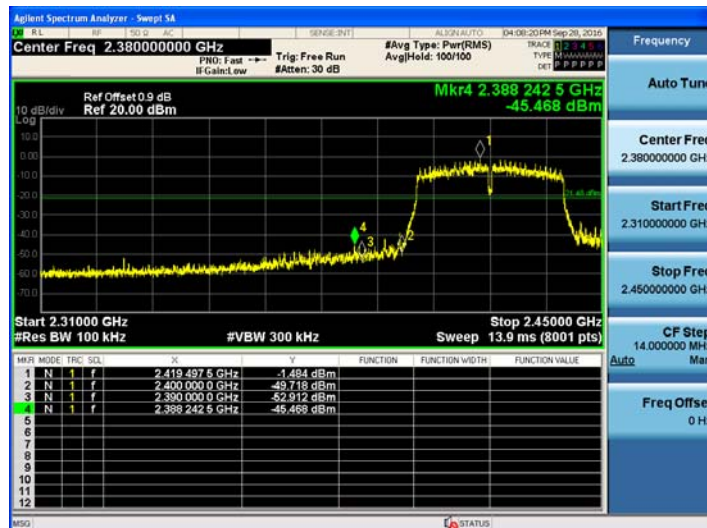
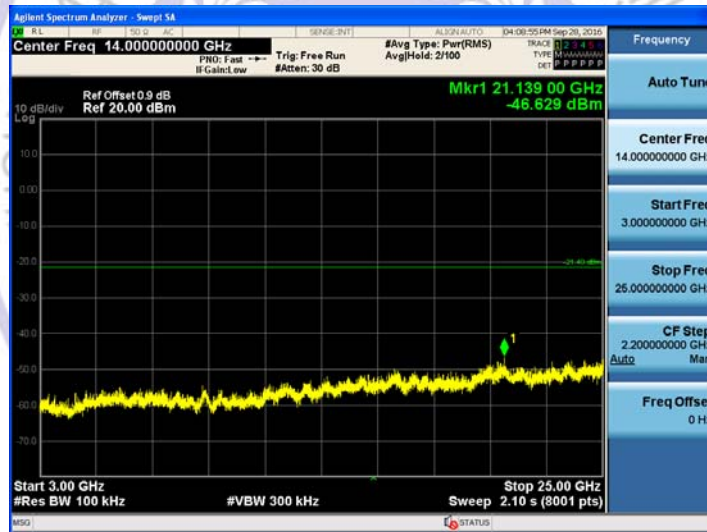
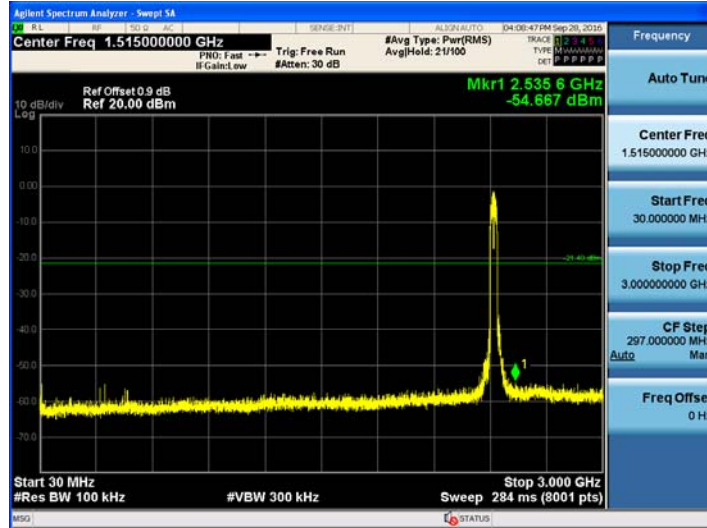

Channel 06 (2437MHz)

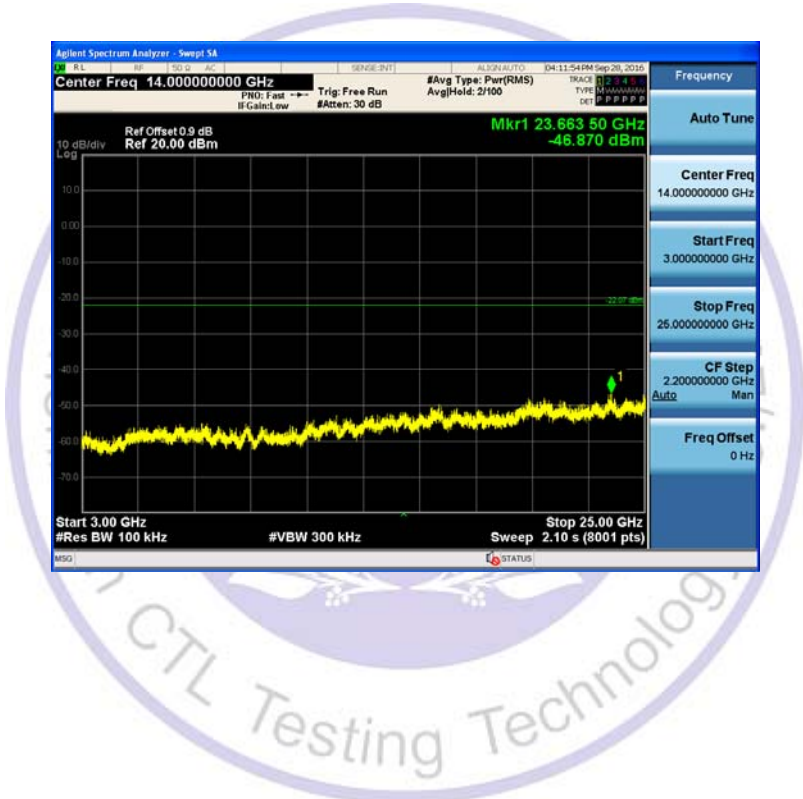
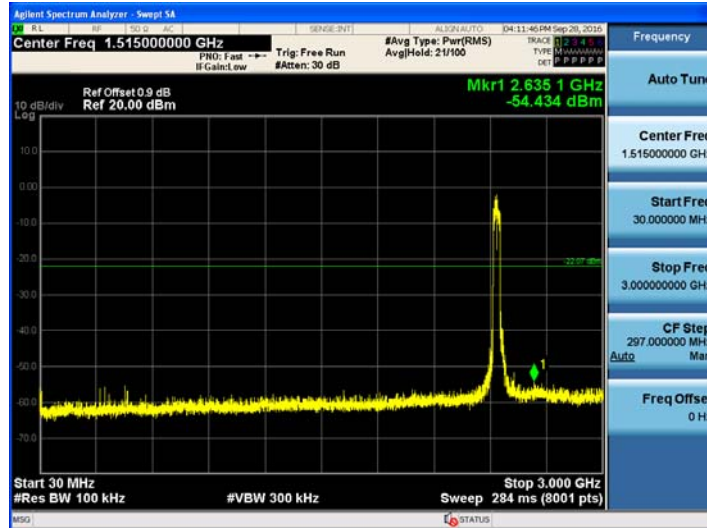

Channel 09 (2452MHz)

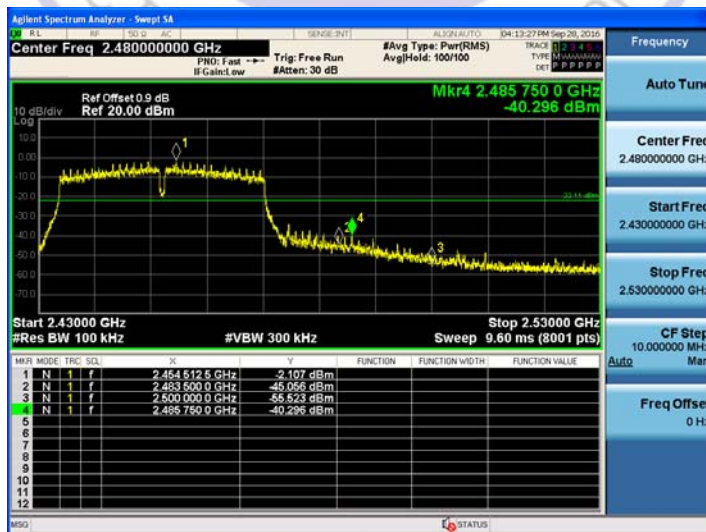
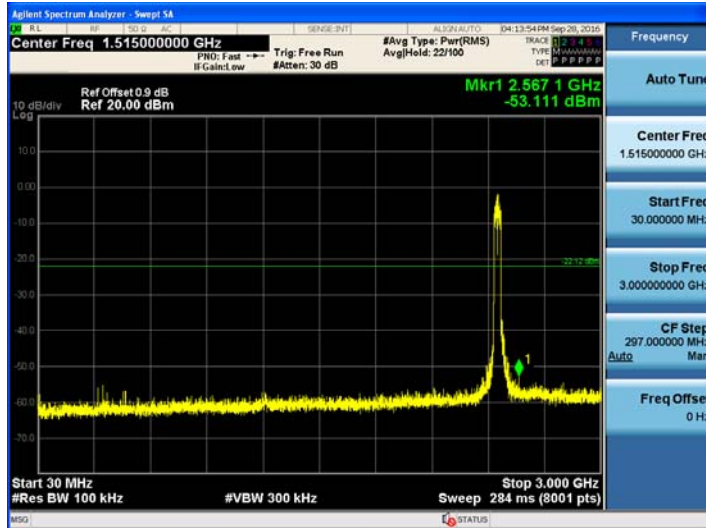

4.8. Antenna Requirement

STANDARD APPLICABLE

For intentional device, according to FCC 47 CFR Section 15.203, an intentional radiator shall be designed to ensure that no antenna other than that furnished by the responsible party shall be used with the device.

And according to FCC 47 CFR Section 15.247 (c), if transmitting antennas of directional gain greater than 6dBi are used, the power shall be reduced by the amount in dB that the directional gain of the antenna exceeds 6dBi.

Refer to statement below for compliance.

The manufacturer may design the unit so that the user can replace a broken antenna, but the use of a standard antenna jack or electrical connector is prohibited. Further, this requirement does not apply to intentional radiators that must be professionally installed.

ANTENNA CONNECTED CONSTRUCTION

The directional gains of antenna used for transmitting is 2 dBi, and the antenna connector is designed with permanent attachment and no consideration of replacement. Please see EUT photo for details.

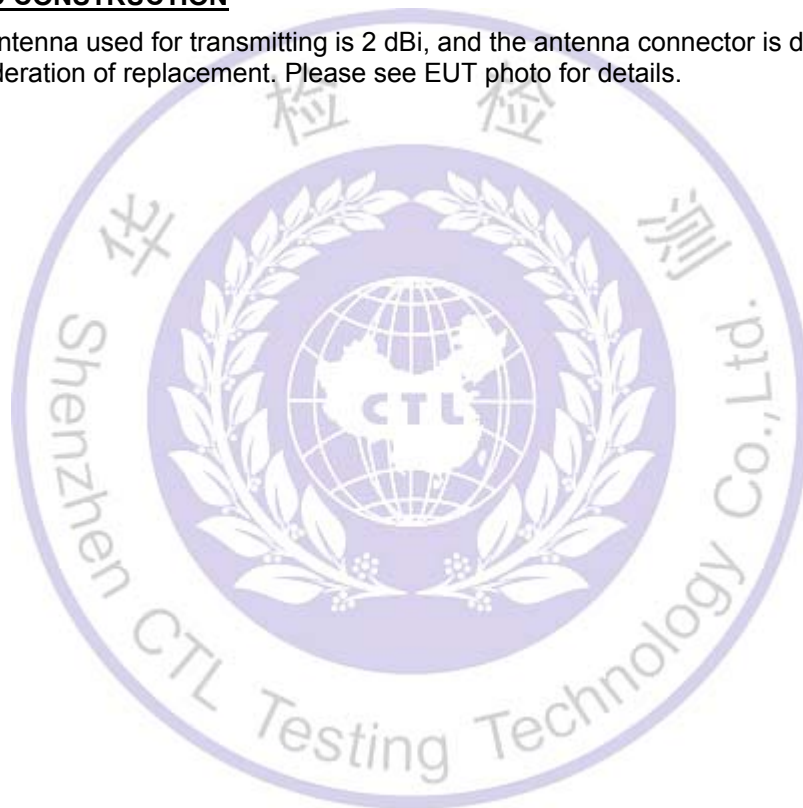

5. Test Setup Photos of the EUT

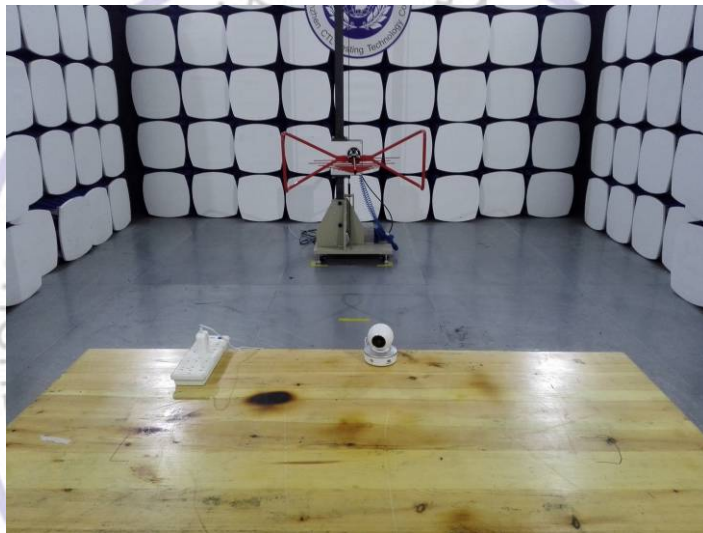
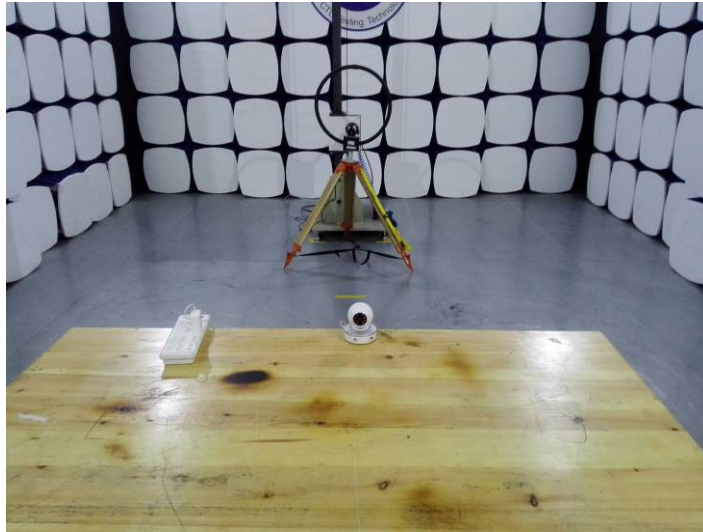



6. External and Internal Photos of the EUT

External Photos of EUT







Internal Photos of EUT

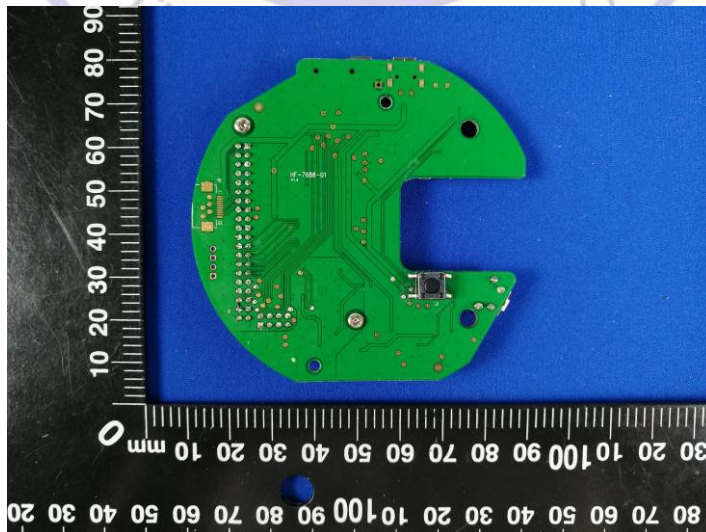
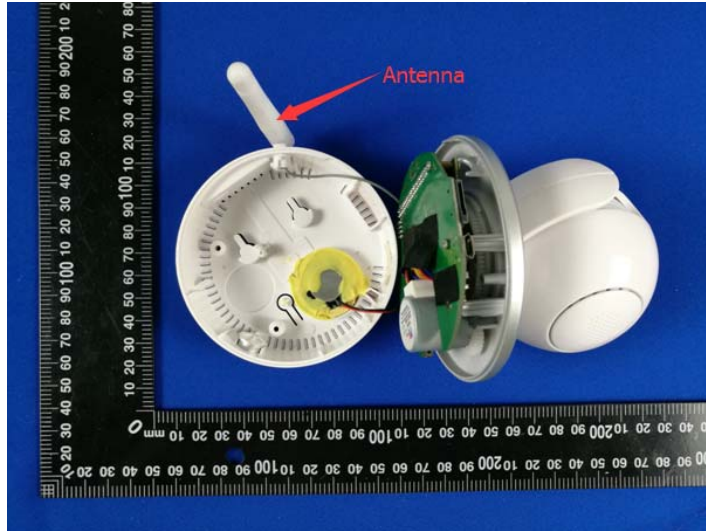

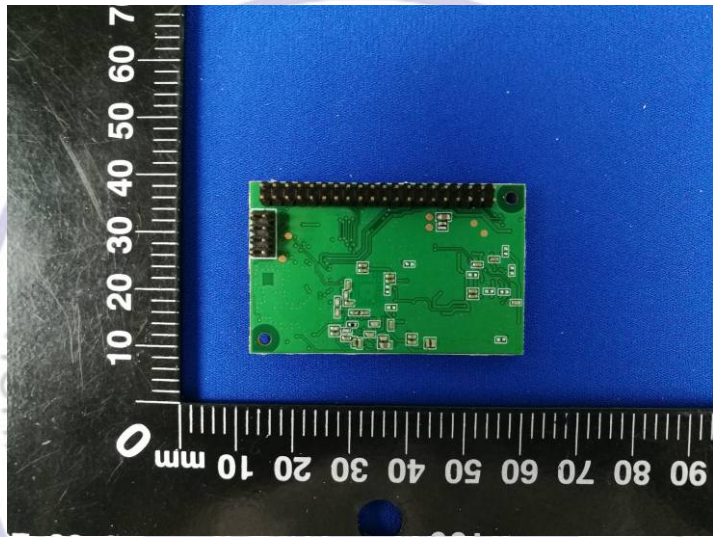
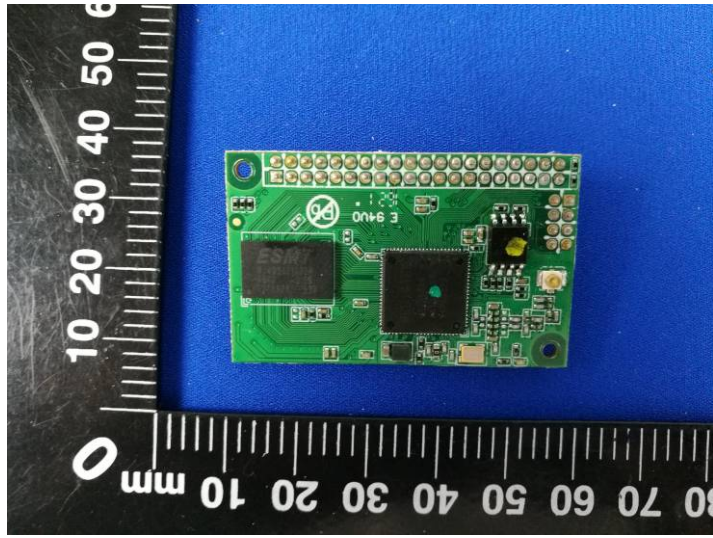

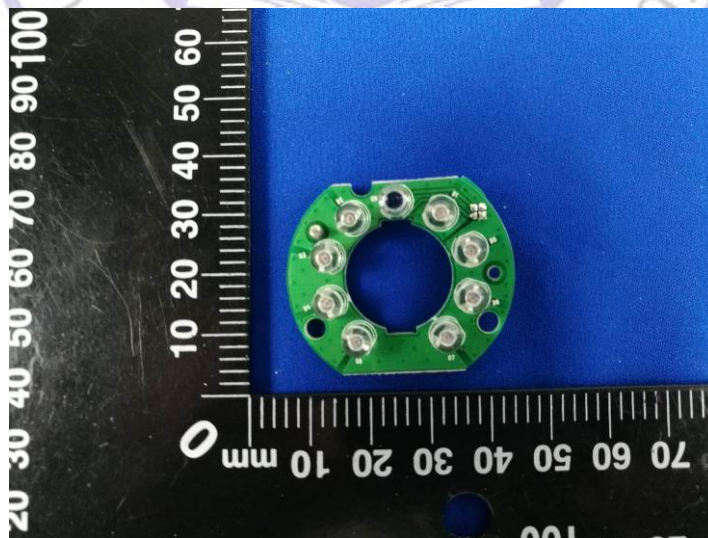
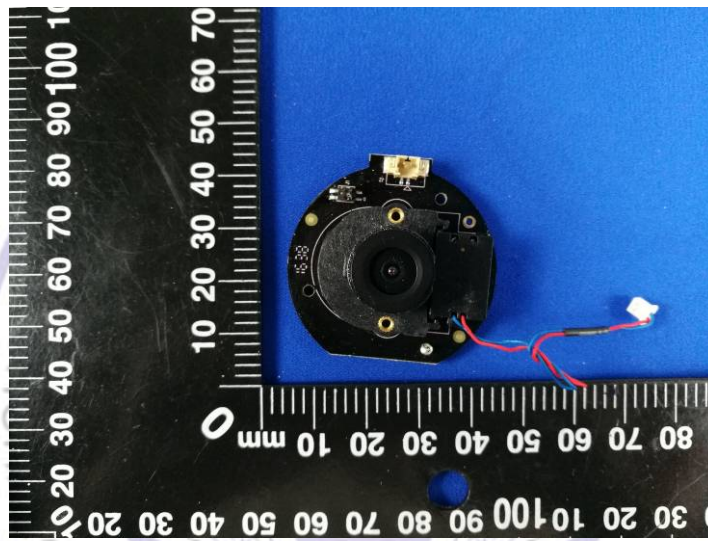
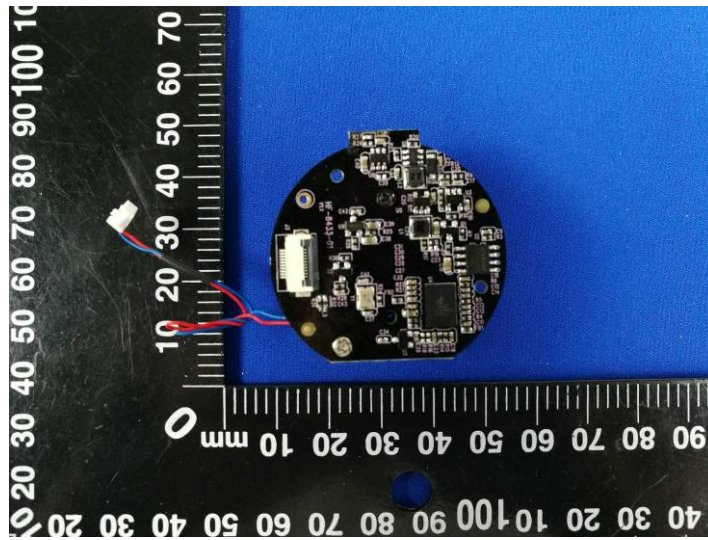

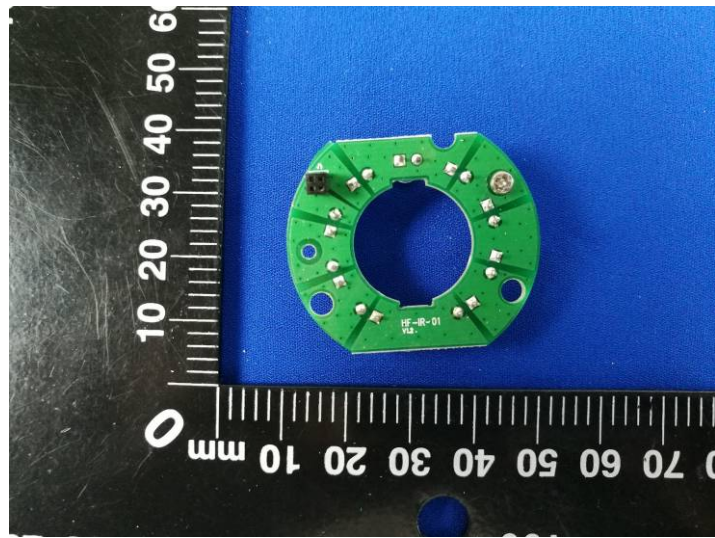

.....End of Report.....

