

P2 Datasheet



Functional description

OVERVIEW

The P2 is a SMD module with a microcontroller and Wi-Fi networking. The form-factor is the same as the P1, but the P2 supports 2.4 GHz and 5 GHz Wi-Fi, BLE, and has much larger RAM and flash that can support larger applications.

FEATURES

- 802.11a/b/g/n Wi-Fi, 2.4 GHz and 5 GHz
 - Integrated PCB antenna
 - Integrated U.FL connector for external antenna
 - Integrated RF switch
- BLE 5 using same antenna as Wi-Fi
- Realtek RTL8721DM MCU
 - ARM Cortex M23 CPU, 200 MHz
- 2048 KB (2 MB) user application maximum size
- 2 MB flash file system
- FCC, IC, and CE certified

Interfaces

BLOCK DIAGRAM

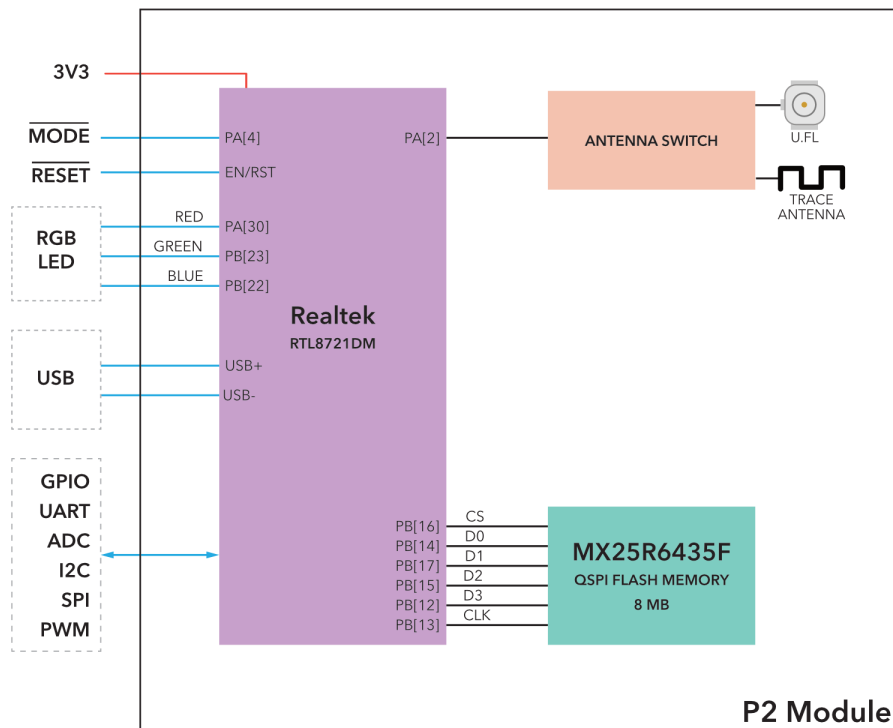

RF

- The P2 includes an on-module PCB trace antenna and a U.FL connector that allows the user to connect an external antenna.
- The antenna is selected in software. The default is the PCB trace antenna.
- The area surrounding the PCB antenna on the carrier PCB should be free of ground planes and signal traces for maximum Wi-Fi performance when using the trace antenna.
- Device operation in the 5150-5250 MHz band is only for indoor use to reduce the potential for harmful interference to co-channel mobile satellite systems.

FCC APPROVED ANTENNAS

Antenna Type	Manufacturer	MFG. Part #	Gain
External antenna	Wistron NeWeb Corporation	95XEAK15.G53	1.55dBi
Internal PCB Antenna	Included	-	2.41dBi

SWD/JTAG

The P2 module supports programming and debugging use SWD (Serial Wire Debug) on pins D6 and D7.

Pin	JTAG	MCU Pin	P2 Pin #	Pull at boot
D7	SWDIO	PA[27]	54	Pull-up
D6	SWCLK	PB[3]	55	Pull-down
3V3	Power			
GND	Ground			
RST	Reset			

When the bootloader starts, for a brief period of time a weak pull-up is applied to pin D7 and pull-down to pin D6 to detect whether a SWD debugger is attached. After boot, you can use these pins for regular GPIO, but beware of a possible GPIO state change caused by the pull-up or pull-down when using these pins as output.

Note that SWD is shared with GPIO pins D6 and D7, and by default SWD is only enabled while the bootloader is running, immediately at boot, and when in DFU mode (blinking yellow). Only Debug builds in Particle Workbench have SWD enabled in when user firmware is running.

Memory Map

DCT LAYOUT

[This information is from the P1, and is likely to remain the same, but is subject to change.]

The DCT area of flash memory has been mapped to a separate DFU media device so that we can incrementally update the application data. This allows one item (say, server public key) to be updated without erasing the other items.

DCT layout in *release/stable* [found here in firmware.](#)

Region	Offset	Size
system flags	0	32
version	32	2
device private key	34	1216
device public key	1250	384
ip config	1634	120
feature flags	1754	4
country code	1758	4
claim code	1762	63
claimed	1825	1
ssid prefix	1826	26
device code	1852	6
version string	1858	32
dns resolve	1890	128
reserved1	2018	64
server public key	2082	768
padding	2850	2
flash modules	2852	100
product store	2952	24
antenna selection	2976	1
cloud transport	2977	1
alt device public key	2978	128
alt device private key	3106	192
alt server public key	3298	192
alt server address	3490	128
device id	3618	12
radio flags	3630	1
mode button mirror	3631	32
led mirror	3663	96
led theme	3759	64
reserved2	3823	435

Note: Writing 0xFF to offset 34 (DEFAULT) or 3106 (ALTERNATE) will cause the device to re-generate a new private key on the next boot. Alternate keys are currently unsupported on the P1 but are used on the Electron as UDP/ECC keys. You should not need to use this feature unless your keys are corrupted.

```
// Regenerate Default Keys
echo -en "\xFF" > fillbyte && dfu-util -d 2b04:d00a -a 1 -s 34 -D fillbyte
// Regenerate Alternate Keys
echo -en "\xFF" > fillbyte && dfu-util -d 2b04:d00a -a 1 -s 3106 -D
fillbyte
```

Pin and button definition

Peripheral Type	Qty	Input(I) / Output(O)
Digital	22	I/O
Analog (ADC)	6	I
SPI	2	I/O
I2C	1	I/O
UART	3	I/O
USB	1	I/O
PWM	6	O

PIN MARKINGS

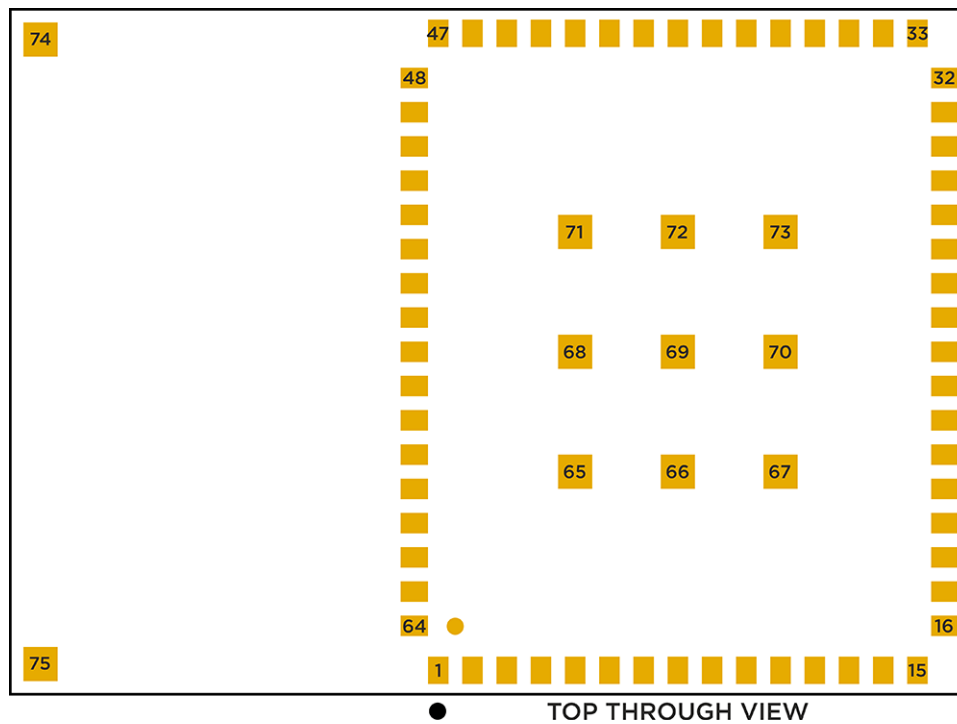

GPIO AND PORT LISTING

Pin Name	Module Pin	MCU
A0 / D11	50	ADC_4 PB[1]
A1 / D12	43	ADC_5 PB[2]
A2 / D13	49	ADC_3 PB[7]
A5 / D14	23	ADC_0 PB[4]
D0 / A3	36	ADC_2 Wire (SDA) PB[6]
D1 / A4	35	ADC_1 Wire (SCL) PB[5]
D10 / WKP	30	Serial3 (CTS) PA[15]
D2	45	SPI1 (MOSI) Serial2 (RTS) PA[16]
D3	51	SPI1 (MISO) Serial2 (CTS) PA[17]
D4	52	SPI1 (SCK) Serial2 (TX) PA[18]
D5	53	SPI1 (SS) Serial2 (RX) PA[19]
D6	55	SWCLK PB[3]
D7	54	SWDIO PA[27]
NC	7	

RGBB	31			PB[22]
RGBG	32			PB[23]
RGBR	29			PA[30]
RX / D9	63		Serial1 (RX)	PA[8]
S0 / D15	40	SPI (MOSI)	Serial3 (TX)	PA[12]
S1 / D16	41	SPI (MISO)	Serial3 (RX)	PA[13]
S2 / D17	42	SPI (SCK)	Serial3 (RTS)	PA[14]
S3 / D18	44	SPI (SS)		PB[26]
S4 / D19	47			PA[0]
S5 / D20	48			PB[29]
S6 / D21	33			PB[31]
TX / D8	64		Serial1 (TX)	PA[7]
USBDATA-	62			PA[25]
USBDATA+	61			PA[26]

ADC (ANALOG TO DIGITAL CONVERTER)

The P2 supports six ADC inputs.

Pin	Pin Name	Description	Interface	MCU
23	A5 / D14	A5 Analog in, GPIO, PWM.	ADC_0	PB[4]
35	D1 / A4	D1 GPIO, PWM, I2C SCL, A4 Analog In	ADC_1	PB[5]
36	D0 / A3	D0 GPIO, PWM, I2C SDA, A3 Analog In	ADC_2	PB[6]
43	A1 / D12	A1 Analog in, GPIO	ADC_5	PB[2]
49	A2 / D13	A2 Analog in, PWM, GPIO	ADC_3	PB[7]
50	A0 / D11	A0 Analog in, GPIO	ADC_4	PB[1]

- ADC inputs are single-ended and limited to 0 to 3.3V
- Resolution is 12 bits

UART SERIAL

The P2 supports three UART serial interfaces.

Pin	Pin Name	Description	Interface	MCU
30	D10 / WKP	D10 GPIO, Serial 3 CTS. (Was WKP/A7 on P1.)	Serial3 (CTS)	PA[15]
40	S0 / D15	S0 GPIO, PWM, SPI MOSI, Serial3 TX. (Was P1S0 on P1.)	Serial3 (TX)	PA[12]
41	S1 / D16	S1 GPIO, PWM, SPI MISO, Serial3 RX. (Was P1S1 on P1.)	Serial3 (RX)	PA[13]
42	S2 / D17	S2 GPIO, SPI SCK, Serial3 RTS. (Was P1S2 on P1.)	Serial3 (RTS)	PA[14]
45	D2	D2 GPIO, Serial2 RTS, SPI1 MOSI	Serial2 (RTS)	PA[16]
51	D3	D3 GPIO, Serial2 CTS, SPI1 MISO	Serial2 (CTS)	PA[17]
52	D4	D4 GPIO, Serial2 TX, SPI1 SCK	Serial2 (TX)	PA[18]
53	D5	D5 GPIO, Serial2 RX, SPI1 SS	Serial2 (RX)	PA[19]
63	RX / D9	Serial1 RX (received data), GPIO	Serial1 (RX)	PA[8]
64	TX / D8	Serial1 TX (transmitted data), GPIO	Serial1 (TX)	PA[7]

- The UART pins are 3.3V and must not be connected directly to a RS-232C port or to a 5V TTL serial port

- Hardware flow control is optional; if not used then the RTS and CTS pins can be used as regular GPIO
- Serial1 uses the RTL872x UART_LOG peripheral
- Serial2 uses the RTL872x HS_UART0 peripheral
- Serial3 uses the RTL872x LP_UART peripheral
- Supported baud rates: 110, 300, 600, 1200, 9600, 14400, 19200, 28800, 38400, 57600, 76800, 115200, 128000, 153600, 230400, 500000, 921600, 1000000, 1382400, 1444400, 1500000, 1843200, 2000000, 2100000, 2764800, 3000000, 3250000, 3692300, 3750000, 4000000, 6000000

SPI

The P2 supports two SPI (serial peripheral interconnect) ports.

Pin	Pin Name	Description	Interface	MCU
40	S0 / D15	S0 GPIO, PWM, SPI MOSI, Serial3 TX. (Was P1S0 on P1.)	SPI (MOSI)	PA[12]
41	S1 / D16	S1 GPIO, PWM, SPI MISO, Serial3 RX. (Was P1S1 on P1.)	SPI (MISO)	PA[13]
42	S2 / D17	S2 GPIO, SPI SCK, Serial3 RTS. (Was P1S2 on P1.)	SPI (SCK)	PA[14]
44	S3 / D18	S3 GPIO. (Was P1S3 on P1.), SPI SS	SPI (SS)	PB[26]
45	D2	D2 GPIO, Serial2 RTS, SPI1 MOSI	SPI1 (MOSI)	PA[16]
51	D3	D3 GPIO, Serial2 CTS, SPI1 MISO	SPI1 (MISO)	PA[17]
52	D4	D4 GPIO, Serial2 TX, SPI1 SCK	SPI1 (SCK)	PA[18]
53	D5	D5 GPIO, Serial2 RX, SPI1 SS	SPI1 (SS)	PA[19]

- The SPI port is 3.3V and must not be connected directly to devices that drive MISO at 5V
- If not using a SPI port, its pins can be used as GPIO
- Any pins can be used as the SPI chip select
- Multiple devices can generally share a single SPI port
- SPI uses the RTL872x SPI1 peripheral (25 MHz maximum speed)
- SPI1 uses the RTL872x SPI0 peripheral (50 MHz maximum speed)

I2C

The P2 supports one I2C (two-wire serial interface) port.

Pin	Pin Name	Description	Interface	MCU
35	D1 / A4	D1 GPIO, PWM, I2C SCL, A4 Analog In	Wire (SCL)	PB[5]
36	D0 / A3	D0 GPIO, PWM, I2C SDA, A3 Analog In	Wire (SDA)	PB[6]

- The I2C port is 3.3V and must not be connected directly a 5V I2C bus
- Maximum bus speed is 400 kHz
- External pull-up resistors are required for I2C
- If not using I2C, pins D0 and D1 can be used as GPIO or analog input.

PWM

The P2 supports PWM (pulse-width modulation) on the following pins:

Pin	Pin Name	Description	MCU
23	A5 / D14	A5 Analog in, GPIO, PWM.	PB[4]
35	D1 / A4	D1 GPIO, PWM, I2C SCL, A4 Analog In	PB[5]
36	D0 / A3	D0 GPIO, PWM, I2C SDA, A3 Analog In	PB[6]

40	S0 / D15	S0 GPIO, PWM, SPI MOSI, Serial3 TX. (Was P1S0 on P1.)	PA[12]
41	S1 / D16	S1 GPIO, PWM, SPI MISO, Serial3 RX. (Was P1S1 on P1.)	PA[13]
49	A2 / D13	A2 Analog in, PWM, GPIO	PB[7]

All available PWM pins on the P2 share a single timer. This means that they must all share a single frequency, but can have different duty cycles.

USB

The P2 supports a USB interface for programming the device and for USB serial (CDC) communications. The module itself does not contain a USB connector; you typically add a micro USB or USB C connector on your base board. It is optional but recommended.

Pin	Pin Name	Description	MCU
61	USBDATA+	USB Data+	PA[26]
62	USBDATA-	USB Data-	PA[25]

RGB LED

The P2 supports an external common anode RGB LED.

One common LED that meets the requirements is the [Cree CLMVC-FKA-CL1D1L71BB7C3C3](#) which is inexpensive and easily procured. You need to add three current limiting resistors. With this LED, we typically use 1K ohm current limiting resistors. These are much larger than necessary. They make the LED less blinding but still provide sufficient current to light the LEDs. If you want maximum brightness you should use the calculated values - 33 ohm on red, and 66 ohm on green and blue.

A detailed explanation of different color codes of the RGB system LED can be found [here](#).

The use of the RGB LED is optional, however it is highly recommended as troubleshooting the device without the LED is very difficult.

Pin	Pin Name	Description	MCU
29	RGBR	RGB LED Red	PA[30]
31	RGBB	RGB LED Blue	PB[22]
32	RGBG	RGB LED Green	PB[23]

SETUP AND RESET BUTTON

It is highly recommended that you add SETUP and RESET buttons to your base board using momentary switches that connect to GND. These are necessary to change the operating mode of the device, for example to enter listening or DFU mode.

Pin	Pin Name	Description	MCU
34	RST	Hardware reset. Pull low to reset; can leave unconnected in normal operation.	CHIP_EN
46	MODE	MODE button, has internal pull-up. Pin number constant is BTN.	PA[4]

COMPLETE MODULE PIN LISTING

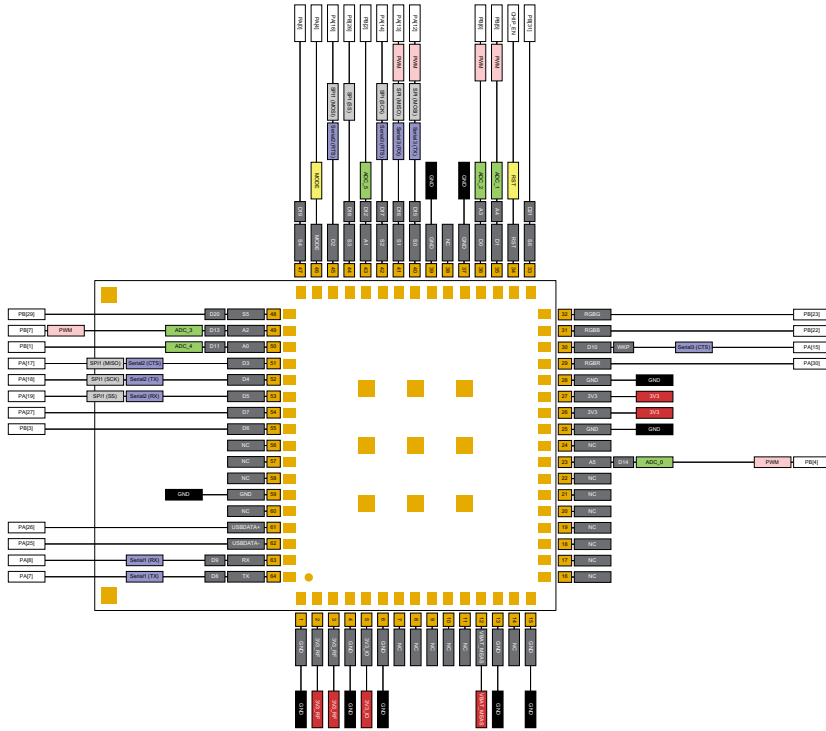

Pin	Pin Name	Description	MCU
1	GND	Ground. Be sure you connect all P1 ground pins.	
2	3V3_RF	3.3V power to RF module	
3	3V3_RF	3.3V power to RF module	
4	GND	Ground. Be sure you connect all P1 ground pins.	
5	3V3_IO	3.3V power to MCU IO.	
6	GND	Ground. Be sure you connect all P1 ground pins.	
7	NC	No connection. Do not connect anything to this pin.	
8	NC	No connection. Do not connect anything to this pin.	
9	NC	No connection. Do not connect anything to this pin.	
10	NC	No connection. Do not connect anything to this pin.	
11	NC	No connection. Do not connect anything to this pin.	
12	VBAT_MEAS	Battery voltage measurement (optional).	
13	GND	Ground. Be sure you connect all P1 ground pins.	
14	NC	No connection. Do not connect anything to this pin.	
15	GND	Ground. Be sure you connect all P1 ground pins.	
16	NC	No connection. Do not connect anything to this pin.	
17	NC	No connection. Do not connect anything to this pin.	
18	NC	No connection. Do not connect anything to this pin.	
19	NC	No connection. Do not connect anything to this pin.	
20	NC	No connection. Do not connect anything to this pin.	
21	NC	No connection. Do not connect anything to this pin.	
22	NC	No connection. Do not connect anything to this pin.	
23	A5/ D14	A5 Analog in, GPIO, PWM.	PB[4]
24	NC	No connection. Do not connect anything to this pin.	
25	GND	Ground. Be sure you connect all P1 ground pins.	
26	3V3	3.3V power to MCU	

27	3V3	3.3V power to MCU	
28	GND	Ground. Be sure you connect all P1 ground pins.	
29	RGBR	RGB LED Red	PA[30]
30	D10 / WKP	D10 GPIO, Serial 3 CTS. (Was WKP/A7 on P1.)	PA[15]
31	RGBB	RGB LED Blue	PB[22]
32	RGBG	RGB LED Green	PB[23]
33	S6 / D21	S6 GPIO. (Was P1S6/TESTMODE on P1.)	PB[31]
34	RST	Hardware reset. Pull low to reset; can leave unconnected in normal operation.	CHIP_EN
35	D1 / A4	D1 GPIO, PWM, I2C SCL, A4 Analog In	PB[5]
36	D0 / A3	D0 GPIO, PWM, I2C SDA, A3 Analog In	PB[6]
37	GND	Ground. Be sure you connect all P1 ground pins.	
38	NC	No connection. Do not connect anything to this pin.	
39	GND	Ground. Be sure you connect all P1 ground pins.	
40	S0 / D15	S0 GPIO, PWM, SPI MOSI, Serial3 TX. (Was P1S0 on P1.)	PA[12]
41	S1 / D16	S1 GPIO, PWM, SPI MISO, Serial3 RX. (Was P1S1 on P1.)	PA[13]
42	S2 / D17	S2 GPIO, SPI SCK, Serial3 RTS. (Was P1S2 on P1.)	PA[14]
43	A1 / D12	A1 Analog in, GPIO	PB[2]
44	S3 / D18	S3 GPIO. (Was P1S3 on P1.), SPI SS	PB[26]
45	D2	D2 GPIO, Serial2 RTS, SPI1 MOSI	PA[16]
46	MODE	MODE button, has internal pull-up. Pin number constant is BTN.	PA[4]
47	S4 / D19	S4 GPIO. (Was P1S4 on P1.)	PA[0]
48	S5 / D20	S5 GPIO. (Was P1S5 on P1.)	PB[29]
49	A2 / D13	A2 Analog in, PWM, GPIO	PB[7]
50	A0 / D11	A0 Analog in, GPIO	PB[1]
51	D3	D3 GPIO, Serial2 CTS, SPI1 MISO	PA[17]
52	D4	D4 GPIO, Serial2 TX, SPI1 SCK	PA[18]
53	D5	D5 GPIO, Serial2 RX, SPI1 SS	PA[19]
54	D7	D7 GPIO, SWDIO	PA[27]
55	D6	D6 GPIO, SWCLK	PB[3]
56	NC	No connection. Do not connect anything to this pin.	
57	NC	No connection. Do not connect anything to this pin.	
58	NC	No connection. Do not connect anything to this pin.	
59	GND	Ground. Be sure you connect all P1 ground pins.	
60	NC	No connection. Do not connect anything to this pin.	
61	USBDATA+	USB Data+	PA[26]
62	USBDATA-	USB Data-	PA[25]
63	RX / D9	Serial1 RX (received data), GPIO	PA[8]
64	TX / D8	Serial1 TX (transmitted data), GPIO	PA[7]
65	GND	Ground. Be sure you connect all P1 ground pins.	
66	GND	Ground. Be sure you connect all P1 ground pins.	
67	GND	Ground. Be sure you connect all P1 ground pins.	
68	GND	Ground. Be sure you connect all P1 ground pins.	
69	GND	Ground. Be sure you connect all P1 ground pins.	
70	GND	Ground. Be sure you connect all P1 ground pins.	
71	GND	Ground. Be sure you connect all P1 ground pins.	

72	GND	Ground. Be sure you connect all P1 ground pins.
73	GND	Ground. Be sure you connect all P1 ground pins.
74	NC	No connection. Do not connect anything to this pin.
75	NC	No connection. Do not connect anything to this pin.

Technical specification

RECOMMENDED OPERATING CONDITIONS

Parameter	Symbol	Min	Typ	Max	Unit
Operating Temperature	T _{op}	-20		+70	°C
Humidity Range Non condensing, relative humidity				95	%

Mechanical specifications

MODULE DIMENSIONS

- P1 module dimensions are: 0.787"(28mm) (W) x 1.102"(20mm) (L) x 0.0787"(2.0mm) (H) +/-0.0039" (0.1mm) (includes metal shielding)
- The P2 should have the same width and length but the height may be slightly different as it has different metal shielding

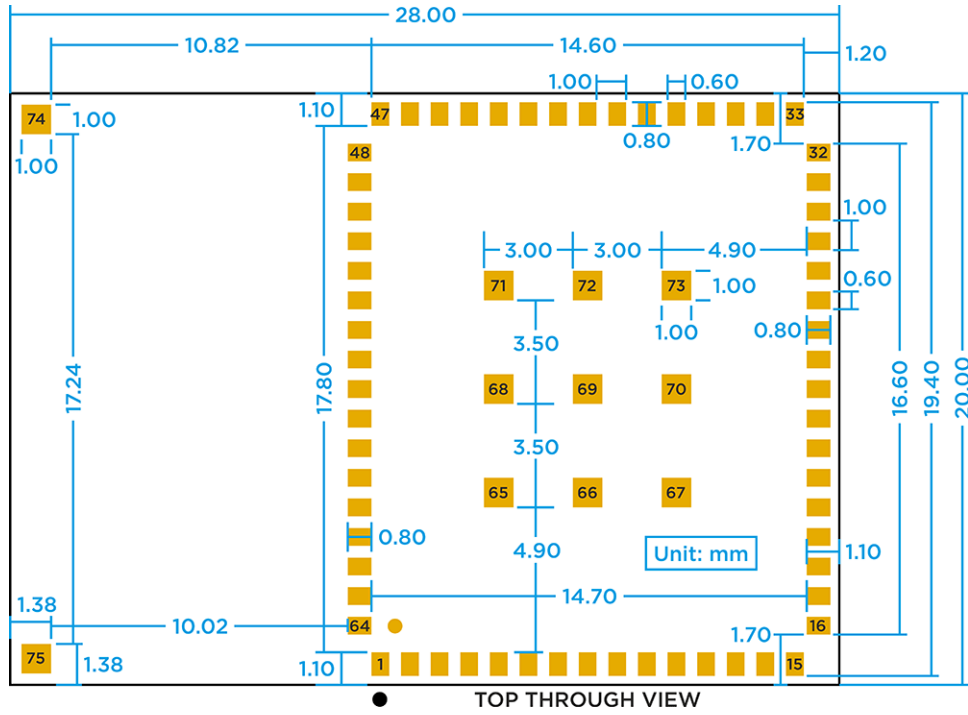

RECOMMENDED PCB LAND PATTERN

The P2 can be mounted directly on a carrier PCB with following PCB land pattern:

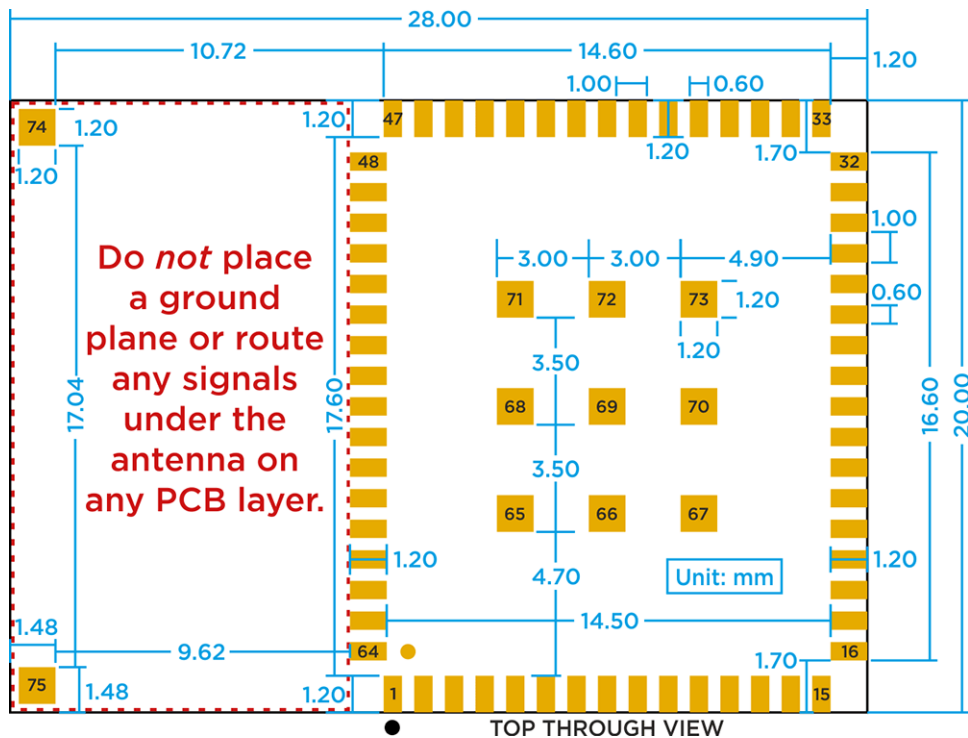

A P1/P2 part for EAGLE can be found in the [Particle EAGLE library](#).

Recommended solder reflow profile

[This information is from the P1, and is likely to remain the same, but is subject to change.]

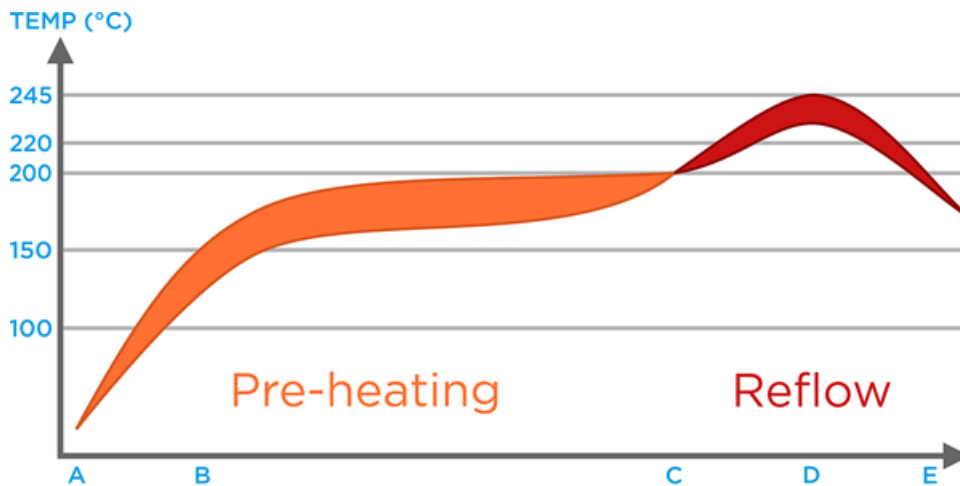

Phase Temperatures and Rates

A-B. Ambient~150°C, Heating rate: < 3°C/s

B-C. 150~200°C, soak time: 60±20 s

C-D. 200~245°C, Heating rate: < 3°C/s

D. Peak temp.: 235~245°C, Time above 220°C: 40±90 s

D-E. 245~220°C, Cooling rate: < 1°C/s

Ordering information

P2 modules are available from store.particle.io as cut tape in quantities of 10 each.

SKU	Description	Region	Lifecycle	Replacement
------------	--------------------	---------------	------------------	--------------------

Qualification and approvals



- RoHS
- CE
- FCC ID: 2AEMI-P2
- IC: 20127-P2

Product handling

MOISTURE SENSITIVITY LEVELS

The Moisture Sensitivity Level (MSL) relates to the packaging and handling precautions required. The P1 module is rated level 3. In general, this precaution applies for Photons without headers. When reflowing a P1 directly onto an application PCB, increased moisture levels prior to reflow can damage sensitive electronics on the P1. A bake process to reduce moisture may be required.

For more information regarding moisture sensitivity levels, labeling, storage and drying see the MSL standard see IPC/JEDEC J-STD-020 (can be downloaded from www.jedec.org).

ESD PRECAUTIONS

The P1 module contains highly sensitive electronic circuitry and is an Electrostatic Sensitive Device (ESD). Handling a P1 module without proper ESD protection may destroy or damage it permanently. Proper ESD handling and packaging procedures must be applied throughout the processing, handling and operation of any application that incorporates P1 modules. ESD precautions should be implemented on the application board where the P1 module is mounted. Failure to observe these precautions can result in severe damage to the P1 module!

Default settings

The P2 module comes pre-programmed with a bootloader and a user application called Tinker. This application works with an iOS and Android app also named Tinker that allows you to very easily toggle digital pins, take analog and digital readings and drive variable PWM outputs.

The bootloader allows you to easily update the user application via several different methods, USB, OTA, Serial Y-Modem, and also internally via the Factory Reset procedure. All of these methods have multiple tools associated with them as well.

You may use the [Particle Web IDE](#) to code, compile and flash a user application OTA (Over The Air). [Particle Workbench](#) is a full-featured desktop IDE for Windows, Mac, and Linux based on VSCode and supports both cloud-based and local gcc-arm compiles. The [Particle CLI](#) provides a command-line interface for cloud-based compiles and flashing code over USB.

Intended applications

The P2 module is intended to be used for Wi-Fi based Internet-of-Things (IoT) applications such as environment, weather, HVAC, equipment, and security monitoring.

The P2 is not certified for use as a wearable device.

Glossary

Radio Frequency

SMT

Surface Mount Technology (often associated with SMD which is a surface mount device).

AP

Access Point

USB

Universal Serial Bus

Quiescent current

Current consumed in the deepest sleep state

FT

Five-tolerant; Refers to a pin being tolerant to 5V.

3V3

+3.3V; The regulated +3.3V supply rail. Also used to note a pin is only 3.3V tolerant.

RTC

Real Time Clock

OTA

Over The Air; describing how firmware is transferred to the device.

FCC IC CE Warnings and End Product Labeling Requirements

The FCC, IC, and CE certifications are radio module certifications only. Additional certification will be required for your completed system.

Federal Communication Commission Interference Statement This equipment has been tested and found to comply with the limits for a Class B digital device, pursuant to Part 15 of the FCC Rules. These limits are designed to provide reasonable protection against harmful interference in a residential installation. This equipment generates, uses and can radiate radio frequency energy and, if not installed and used in accordance with the instructions, may cause harmful interference to radio communications. However, there is no guarantee that interference will not occur in a particular installation. If this equipment does cause harmful interference to radio or television reception, which can be determined by turning the equipment off and on, the user is encouraged to try to correct the interference by one of the following measures:

- Reorient or relocate the receiving antenna.
- Increase the separation between the equipment and receiver.
- Connect the equipment into an outlet on a circuit different from that to which the receiver is connected.
- Consult the dealer or an experienced radio/TV technician for help.

FCC Caution: Any changes or modifications not expressly approved by the party responsible for compliance could void the user's authority to operate this equipment. This device complies with Part 15 of the FCC Rules. Operation is subject to the following two conditions:

1. This device may not cause harmful interference, and
2. This device must accept any interference received, including interference that may cause undesired operation.

FCC Radiation Exposure Statement: This equipment complies with FCC radiation exposure limits set forth for an uncontrolled environment. This transmitter module must not be co-located or operating in conjunction with any other antenna or transmitter. This End equipment should be installed and operated with a minimum distance of 20 centimeters between the radiator and your body.

IMPORTANT NOTE: In the event that these conditions can not be met (for example certain laptop configurations or co-location with another transmitter), then the FCC authorization is no longer considered valid and the FCC ID can not be used on the final product. In these circumstances, the OEM integrator will be responsible for re-evaluating the end product (including the transmitter) and obtaining a separate FCC authorization.

End Product Labeling The final end product must be labeled in a visible area with the following:

Contains FCC ID: 2AEMI-P2

Manual Information to the End User The OEM integrator has to be aware not to provide information to the end user regarding how to install or remove this RF module in the user's manual of the end product which integrates this module.

Canada Statement This device complies with Industry Canada's licence-exempt RSSs. Operation is subject to the following two conditions:

1. This device may not cause interference; and
2. This device must accept any interference, including interference that may cause undesired operation of the device.

Le présent appareil est conforme aux CNR d'Industrie Canada applicables aux appareils radio exempts de licence.

L'exploitation est autorisée aux deux conditions suivantes:

1. l'appareil ne doit pas produire de brouillage;
2. l'utilisateur de l'appareil doit accepter tout brouillage radioélectrique subi, même si le brouillage est susceptible d'en compromettre le fonctionnement.

Caution Exposure: This device meets the exemption from the routine evaluation limits in section 2.5 of RSS102 and users can obtain Canadian information on RF exposure and compliance. Le dispositif répond à l'exemption des limites d'évaluation de routine dans la section 2.5 de RSS102 et les utilisateurs peuvent obtenir des renseignements canadiens sur l'exposition aux RF et le respect.

The final end product must be labelled in a visible area with the following: The Industry Canada certification label of a module shall be clearly visible at all times when installed in the host device, otherwise the host device must be labelled to display the Industry Canada certification number of the module, preceded by the words "Contains transmitter module", or the word "Contains", or similar wording expressing the same meaning, as follows:

Contains transmitter module IC: 20127-P2

This End equipment should be installed and operated with a minimum distance of 20 centimeters between the radiator and your body. Cet équipement devrait être installé et actionné avec une distance minimum de 20 centimètres entre le radiateur et votre corps.

The end user manual shall include all required regulatory information/warning as shown in this manual.

Revision history

Revision	Date	Author	Comments
pre	2021-11-04	RK	Pre-release
	2022-02-08	RK	Corrected D pin aliases for A5 and S0-S6
	2022-02-25	RK	Changed D pin aliases for D9 - D22, A5 is not SPI MOSI, Serial2 TX and RX were reversed
	2022-03-14	RK	Minor edits; no functional changes
	2022-03-23	RK	Added FCC and IC IDs, operating temperature range
	2022-04-12	RK	Added serial baud rates
	2022-04-16	RK	Added Serial3
	2022-05-07	RK	Temperature range is -20°C to +70°C
	2022-05-27	RK	Updated antenna information, rendering
	2022-06-03	RK	Added note about module certification
	2022-06-08	RK	Added intended applications section, changed reference to ARM M4F to M33

D PIN CHANGE (2022-02-25)

The names of pins D9 - D22 have been changed to D8 - D21, eliminating the odd situation where there was previously no pin D8. This prevented being able to use a loop to initialize pins. This should not affect the hardware in any way, but software that used the D pin names instead of their more common names like TX (was D9, now D8) would need to be updated.

Pin	Old Pin Name	New Pin Name	Description	MCU
64	D9	TX / D8	Serial1 TX (transmitted data), GPIO	PA[7]
63	D10	RX / D9	Serial1 RX (received data), GPIO	PA[8]
30	D11	D10 / WKP	D10 GPIO, Serial 3 CTS. (Was WKP/A7 on P1.)	PA[15]
50	D12	A0 / D11	A0 Analog in, GPIO	PB[1]
43	D13	A1 / D12	A1 Analog in, GPIO	PB[2]
49	D14	A2 / D13	A2 Analog in, PWM, GPIO	PB[7]
23	D15	A5 / D14	A5 Analog in, GPIO, PWM.	PB[4]
40	D16	S0 / D15	S0 GPIO, PWM, SPI MOSI, Serial3 TX. (Was P1S0 on P1.)	PA[12]
41	D17	S1 / D16	S1 GPIO, PWM, SPI MISO, Serial3 RX. (Was P1S1 on P1.)	PA[13]
42	D18	S2 / D17	S2 GPIO, SPI SCK, Serial3 RTS. (Was P1S2 on P1.)	PA[14]
44	D19	S3 / D18	S3 GPIO. (Was P1S3 on P1.), SPI SS	PB[26]
47	D20	S4 / D19	S4 GPIO. (Was P1S4 on P1.)	PA[0]
48	D21	S5 / D20	S5 GPIO. (Was P1S5 on P1.)	PB[29]
33	D22	S6 / D21	S6 GPIO. (Was P1S6/TESTMODE on P1.)	PB[31]

Known Errata

Contact

Web

<https://www.particle.io>

Community Forums

<https://community.particle.io>

Email

<https://support.particle.io>