

under the conditions specified in §2.1049 as appropriate. The magnitude of spurious emissions which are attenuated more than 20 dB below the permissible value need not be specified.

Part 24, Subpart E – Broadband PCS

§24.238 – Emission limitations for Broadband PCS equipment

- a) Out of band emissions. The power of any emission outside of the authorized operating frequency ranges must be attenuated below the transmitting power (P) by a factor of at least $43 + 10 \log(P)$ dB.
- b) Measurement procedure. Compliance with these rules is based on the use of measurement instrumentation employing a resolution bandwidth of 1 MHz or greater. However, in the 1 MHz bands immediately outside and adjacent to the frequency block a resolution bandwidth of at least one percent of the emission bandwidth of the fundamental emission of the transmitter may be employed. A narrower resolution bandwidth is permitted in all cases to improve measurement accuracy provided the measured power is integrated over the full required measurement bandwidth (i.e. 1 MHz or 1 percent of emission bandwidth, as specified). The emission bandwidth is defined as the width of the signal between two points, one below the carrier center frequency and one above the carrier center frequency, outside of which all emissions are attenuated at least 26 dB below the transmitter power.

RSS-133; 6.5 Transmitter Unwanted Emissions

Mobile and base station equipment shall comply with the limits in (1) and (2) below.

- 1. In the 1.0 MHz bands immediately outside and adjacent to the equipment’s operating frequency block, the emission power per any 1% of the emission bandwidth shall be attenuated (in dB) below the transmitter output power P (dBW) by at least $43 + 10 \log_{10}p$ (watts).
- 2. After the first 1.0 MHz, the emission power in any 1 MHz bandwidth shall be attenuated (in dB) below the transmitter output power P (dBW) by at least $43 + 10 \log_{10}p$ (watts). If the measurement is performed using 1% of the emission bandwidth, power integration over 1.0 MHz is required.

5.13.3 TEST PROTOCOL

Temperature 20 – 25 °C
Humidity 30 - 40 %

Radio Technology	Channel	Re-source Blocks / Subcarrier	Band-width [MHz]	Peak [dBm]	Average [dBm]	RMS [dBm]	Limit /dBm	Margin to Limit /dB
NB-IoT eFDD 2 QPSK	low	12	0.2	-6.33	-25.90	-18.06	-13	5.06
NB-IoT eFDD 2 QPSK	high	12	0.2	-4.02	-30.02	-18.22	-13	5.22
NB-IoT eFDD 2 BPSK	low	1	0.2	-5.11	-20.28	-19.11	-13	6.11
NB-IoT eFDD 2 BPSK	high	1	0.2	-6.00	-12.24	-16.71	-13	3.71

Remark: Please see next sub-clause for the measurement plot.

5.13.4 MEASUREMENT PLOT (EXAMPLE PLOT, SHOWING WORST CASE, IF APPLICABLE)

NB-IoT eFDD2 BPSK, Channel = high

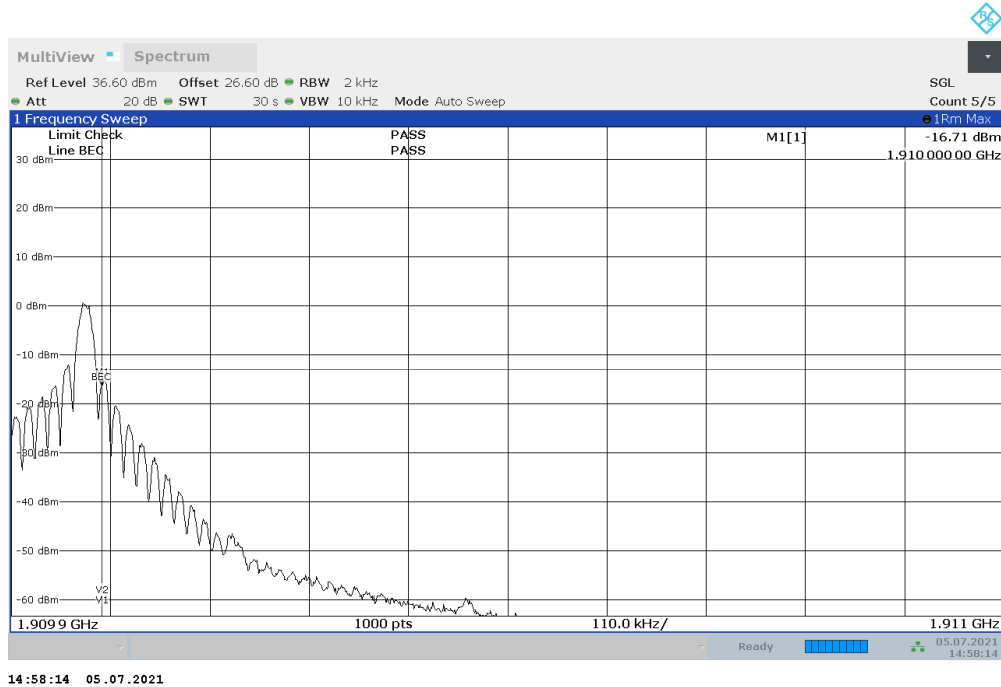

5.13.5 TEST EQUIPMENT USED

- Radio Lab

5.14 PEAK TO AVERAGE RATIO

Standard **FCC PART 24 Subpart E**

The test was performed according to:
ANSI C63.26: 2015

5.14.1 TEST DESCRIPTION

This test case is intended to demonstrate compliance of the EUT to the peak-to-average limits and requirements of the applicable rule part and ISED RSS-Standard for the operating band of the cellular device.

The EUT was connected to the test setup according to the following diagram:

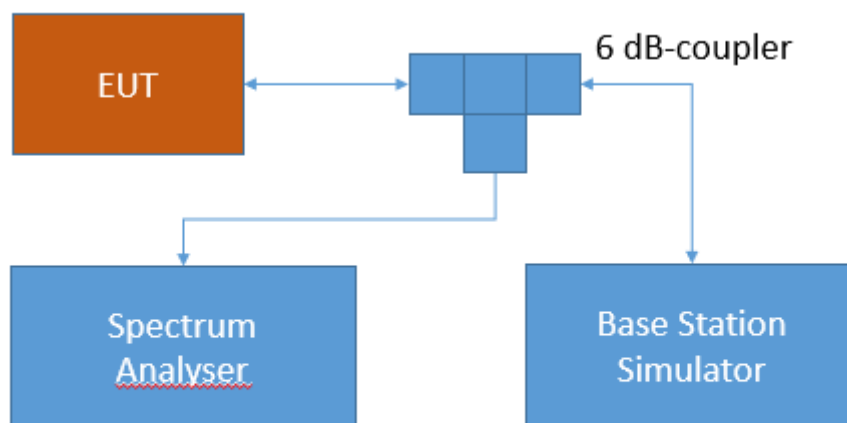

Test Setup FCC Part 22/24/27/90 Cellular;
Peak-average ratio

The attenuation of the measuring and stimulus path are known for each measured frequency and are considered.

The Spectrum Analyzer settings can be directly found in the measurement diagrams. The internal CCDF (complementary cumulative distribution function) of the spectrum analyser is used for this measurement

5.14.2 TEST REQUIREMENTS / LIMITS

FCC Part 24, § 24.232

(d) Power measurements for transmissions by stations authorized under this section may be made either in accordance with a Commission-approved average power technique or in

compliance with paragraph (e) of this section. In both instances, equipment employed must be authorized in accordance with the provisions of §24.51. In measuring transmissions in this band using an average power technique, the peak-to-average ratio (PAR) of the transmission may not exceed 13 dB.

RSS-133; 6.4 Transmitter Output Power and Equivalent Isotropically Radiated Power

In addition, the peak-to-average power ratio (PAPR) of the transmitter shall not exceed 13 dB for more than 0.1% of the time using a signal corresponding to the highest PAPR during periods of continuous transmission.

5.14.3 TEST PROTOCOL

Temperature 20 – 25 °C
Humidity 30 - 40 %

Radio Technology	Channel	Re-source Blocks / Subcarrier	Bandwidth [MHz]	Peak to Average Ratio	Limit (IC) [dB]
NB-IoT eFDD 2 QPSK	low	12	0.2	8.22	13
NB-IoT eFDD 2 QPSK	mid	12	0.2	8.90	13
NB-IoT eFDD 2 QPSK	high	12	0.2	8.30	13
NB-IoT eFDD 2 BPSK	low	1	0.2	3.90	13
NB-IoT eFDD 2 BPSK	mid	1	0.2	3.92	13
NB-IoT eFDD 2 BPSK	high	1	0.2	3.90	13

Remark: Please see next sub-clause for the measurement plot.

5.14.4 MEASUREMENT PLOT (EXAMPLE PLOT, SHOWING WORST CASE, IF APPLICABLE)

NB-IoT eFDD2 QPSK, Channel = mid

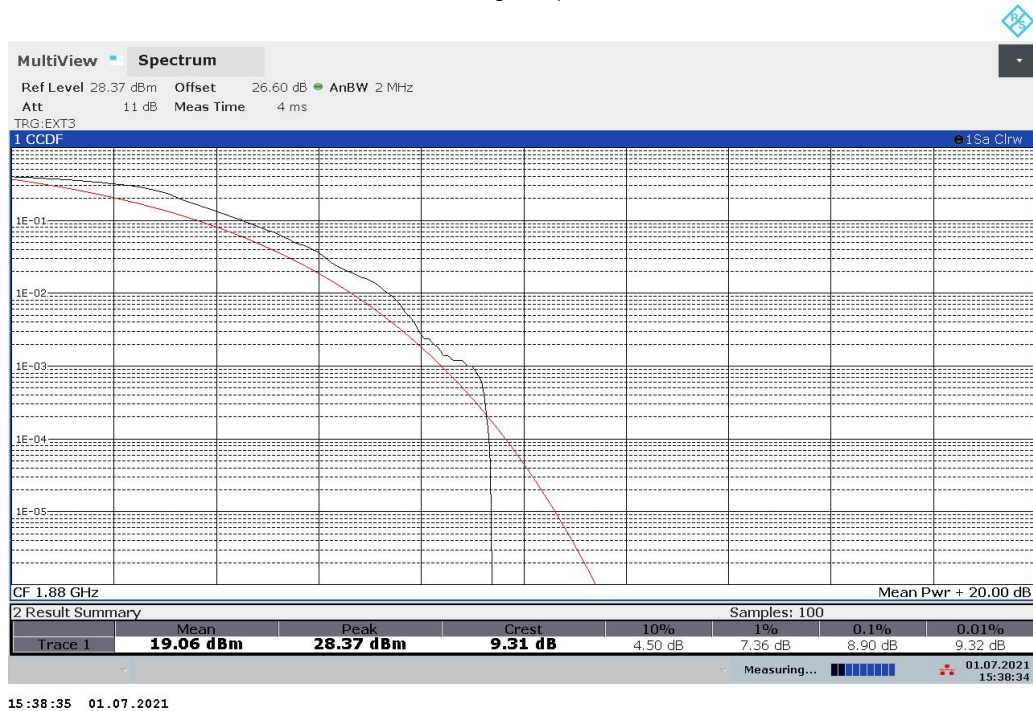

5.14.5 TEST EQUIPMENT USED

- Radio Lab

5.15 RF OUTPUT POWER

Standard **FCC PART 27 Subpart C**

The test was performed according to:
ANSI C63.26: 2015

5.15.1 TEST DESCRIPTION

This test case is intended to demonstrate compliance to the applicable RF Output power test case per § 2.1046 and RSS-GEN 6.12. The limit and the requirements come from the applicable rule part and ISED RSS-Standard for the operating band of the cellular device.

The EUT was connected to the test setup according to the following diagram:

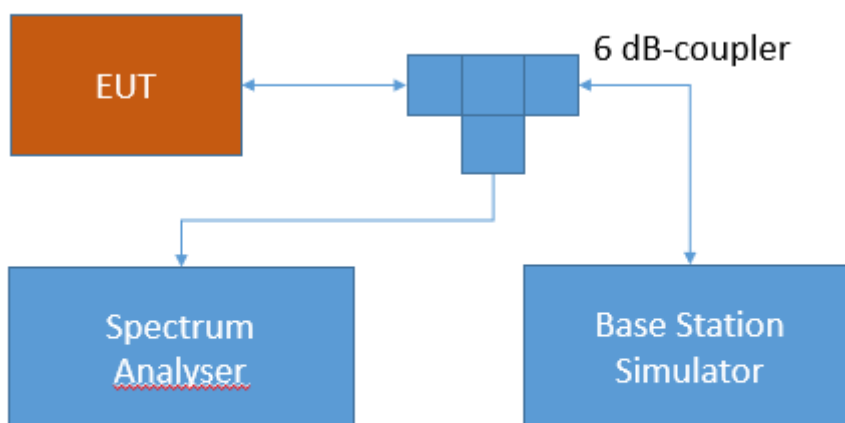

Test Setup FCC Part 22/24/27/90 Cellular;
RF Output power

The attenuation of the measuring and stimulus path are known for each measured frequency and are considered.

The Spectrum Analyzer settings can be directly found in the measurement diagrams.

5.15.2 TEST REQUIREMENTS / LIMITS

FCC Part 27; Miscellaneous Wireless Communication Services

Subpart C – Technical standards

§ 27.50 - Power limits and duty cycle

Band 13:

(b) The following power limits apply to transmitters operating in the 746-758 MHz, 775-788 MHz and 805-806 MHz bands:

(10) Portable stations (hand-held devices) transmitting in the 746-757 MHz, 776-788 MHz, and 805-806 MHz bands are limited to 3 watts ERP.

RSS-130; 4.6.3 Transmitter Output Power

The e.r.p. shall not exceed 3 watts for portable equipment and indoor fixed subscriber equipment.

Band 12:

c) The following power and antenna height requirements apply to stations transmitting in the 600 MHz band and the 698-746 MHz band:

(10) Portable stations (hand-held devices) in the 600 MHz uplink band and the 698-746 MHz band, and fixed and mobile stations in the 600 MHz uplink band are limited to 3 watts ERP.

RSS-130; 4.6.3 Transmitter Output Power

The e.r.p. shall not exceed 3 watts for portable equipment and indoor fixed subscriber equipment.

Band 4/10/66:

d) The following power and antenna height requirements apply to stations transmitting in the 1695-1710 MHz, 1710-1755 MHz, 1755-1780 MHz, 1915-1920 MHz, 1995-2000 MHz, 2000-2020 MHz, 2110-2155 MHz, 2155-2180 MHz and 2180-2200 MHz bands:

(4) Fixed, mobile, and portable (hand-held) stations operating in the 1710-1755 MHz band and mobile and portable stations operating in the 1695-1710 MHz and 1755-1780 MHz bands are limited to 1 watt EIRP. Fixed stations operating in the 1710-1755 MHz band are limited to a maximum antenna height of 10 meters above ground. Mobile and portable stations operating in these bands must employ a means for limiting power to the minimum.

RSS-139; 6.5 Transmitter Output Power

The equivalent isotropically radiated power (e.i.r.p.) for mobile and portable transmitters shall not exceed one watt.

Band 17:

(c) The following power requirements apply to stations transmitting in the 600 MHz band and the 698-746 MHz band:

(10) Portable stations (hand-held devices) in the 600 MHz uplink band and the 698-746 MHz band, and fixed and mobile stations in the 600 MHz uplink band are limited to 3 watts ERP.

RSS-130; 4.6.3 Transmitter Output

The e.r.p. shall not exceed 3 watts for portable equipment and indoor fixed subscriber equipment.

Band 7:

(h) The following power limits shall apply in the BRS and EBS:

(2) Mobile and other user stations. Mobile stations are limited to 2.0 watts EIRP. All user stations are limited to 2.0 watts transmitter output power.

RSS-199; 4.4 Transmitter output power and equivalent isotropically power (e.i.r.p.)

The transmitter output power shall be measured in terms of average value.

For mobile subscriber equipment, the e.i.r.p. shall not exceed 2 W. For fixed subscriber equipment, the transmitter output power shall not exceed 2 W and the e.i.r.p. shall be limited to 40 W.

For equipment with multiple antennas, the transmitter output power and e.i.r.p shall be measured according to ANSI C63.26-2015.

5.15.3 TEST PROTOCOL

Temperature 20 – 25 °C
Humidity 30 - 40 %

Radio Technology	Channel	Res- source Blocks	Band- width [MHz]	RMS Cond. Power (dBm)	FCC EIRP Limit	IC EIRP Limit	Max. Antenna Gain FCC (dBi)	Max. Anten na Gain IC (dBi)
CAT-M1 eFDD 4 QPSK	mid	1	1.4	23.56	1 (EIRP)	1 (EIRP)	6.44	6.44
CAT-M1 eFDD 4 QPSK	mid	3	1.4	22.25	1 (EIRP)	1 (EIRP)	7.75	7.75
CAT-M1 eFDD 4 QPSK	mid	6	1.4	21.43	1 (EIRP)	1 (EIRP)	8.57	8.57
CAT-M1 eFDD 4 16QAM	mid	1	1.4	21.93	1 (EIRP)	1 (EIRP)	8.07	8.07
CAT-M1 eFDD 4 16QAM	mid	5	1.4	21.61	1 (EIRP)	1 (EIRP)	8.39	8.39
CAT-M1 eFDD 4 QPSK	mid	1	3	23.54	1 (EIRP)	1 (EIRP)	6.46	6.46
CAT-M1 eFDD 4 QPSK	mid	3	3	22.26	1 (EIRP)	1 (EIRP)	7.74	7.74
CAT-M1 eFDD 4 QPSK	mid	6	3	21.45	1 (EIRP)	1 (EIRP)	8.55	8.55
CAT-M1 eFDD 4 16QAM	mid	1	3	21.93	1 (EIRP)	1 (EIRP)	8.07	8.07
CAT-M1 eFDD 4 16QAM	mid	5	3	21.65	1 (EIRP)	1 (EIRP)	8.35	8.35
CAT-M1 eFDD 4 QPSK	mid	1	5	23.56	1 (EIRP)	1 (EIRP)	6.44	6.44
CAT-M1 eFDD 4 QPSK	mid	3	5	22.27	1 (EIRP)	1 (EIRP)	7.73	7.73
CAT-M1 eFDD 4 QPSK	mid	6	5	22.37	1 (EIRP)	1 (EIRP)	7.63	7.63
CAT-M1 eFDD 4 16QAM	mid	1	5	23.17	1 (EIRP)	1 (EIRP)	6.83	6.83
CAT-M1 eFDD 4 16QAM	mid	5	5	21.64	1 (EIRP)	1 (EIRP)	8.36	8.36
CAT-M1 eFDD 4 QPSK	mid	1	10	23.51	1 (EIRP)	1 (EIRP)	6.49	6.49
CAT-M1 eFDD 4 QPSK	mid	3	10	23.46	1 (EIRP)	1 (EIRP)	6.54	6.54
CAT-M1 eFDD 4 QPSK	mid	6	10	22.41	1 (EIRP)	1 (EIRP)	7.59	7.59
CAT-M1 eFDD 4 16QAM	mid	1	10	23.19	1 (EIRP)	1 (EIRP)	6.81	6.81
CAT-M1 eFDD 4 16QAM	mid	5	10	22.54	1 (EIRP)	1 (EIRP)	7.46	7.46
CAT-M1 eFDD 8 QPSK	low	1	1.4	22.51	3 (ERP)	-	12.26	-
CAT-M1 eFDD 8 QPSK	low	3	1.4	21.32	3 (ERP)	-	13.45	-
CAT-M1 eFDD 8 QPSK	low	6	1.4	20.40	3 (ERP)	-	14.37	-
CAT-M1 eFDD 8 QPSK	mid	1	1.4	22.51	3 (ERP)	-	12.26	-
CAT-M1 eFDD 8 QPSK	mid	3	1.4	21.33	3 (ERP)	-	13.44	-
CAT-M1 eFDD 8 QPSK	mid	6	1.4	20.44	3 (ERP)	-	14.33	-
CAT-M1 eFDD 8 QPSK	high	1	1.4	22.48	3 (ERP)	-	12.29	-
CAT-M1 eFDD 8 QPSK	high	3	1.4	21.31	3 (ERP)	-	13.46	-
CAT-M1 eFDD 8 QPSK	high	6	1.4	20.37	3 (ERP)	-	14.4	-
CAT-M1 eFDD 8 16QAM	low	1	1.4	20.98	3 (ERP)	-	13.79	-
CAT-M1 eFDD 8 16QAM	low	5	1.4	20.61	3 (ERP)	-	14.16	-
CAT-M1 eFDD 8 16QAM	mid	1	1.4	20.96	3 (ERP)	-	13.81	-
CAT-M1 eFDD 8 16QAM	mid	5	1.4	20.61	3 (ERP)	-	14.16	-
CAT-M1 eFDD 8 16QAM	high	1	1.4	20.97	3 (ERP)	-	13.8	-
CAT-M1 eFDD 8 16QAM	high	5	1.4	20.56	3 (ERP)	-	14.21	-
CAT-M1 eFDD 8 QPSK	mid	1	3	21.91	3 (ERP)	-	12.86	-
CAT-M1 eFDD 8 QPSK	mid	3	3	21.29	3 (ERP)	-	13.48	-
CAT-M1 eFDD 8 QPSK	mid	6	3	20.38	3 (ERP)	-	14.39	-
CAT-M1 eFDD 8 16QAM	mid	1	3	20.95	3 (ERP)	-	13.82	-

CAT-M1 eFDD 8 16QAM	mid	5	3	20.60	3 (ERP)	-	14.17	-
CAT-M1 eFDD 12 QPSK	mid	1	1.4	23.00	3 (ERP)	3 (ERP)	11.77	11.77
CAT-M1 eFDD 12 QPSK	mid	3	1.4	21.95	3 (ERP)	3 (ERP)	12.82	12.82
CAT-M1 eFDD 12 QPSK	mid	6	1.4	20.88	3 (ERP)	3 (ERP)	13.89	13.89
CAT-M1 eFDD 12 16QAM	mid	1	1.4	21.65	3 (ERP)	3 (ERP)	13.12	13.12
CAT-M1 eFDD 12 16QAM	mid	5	1.4	21.11	3 (ERP)	3 (ERP)	13.66	13.66
CAT-M1 eFDD 12 QPSK	mid	1	3	22.99	3 (ERP)	3 (ERP)	11.78	11.78
CAT-M1 eFDD 12 QPSK	mid	3	3	21.86	3 (ERP)	3 (ERP)	12.91	12.91
CAT-M1 eFDD 12 QPSK	mid	6	3	20.84	3 (ERP)	3 (ERP)	13.93	13.93
CAT-M1 eFDD 12 16QAM	mid	1	3	21.66	3 (ERP)	3 (ERP)	13.11	13.11
CAT-M1 eFDD 12 16QAM	mid	5	3	21.05	3 (ERP)	3 (ERP)	13.72	13.72
CAT-M1 eFDD 12 QPSK	mid	1	5	22.91	3 (ERP)	3 (ERP)	11.86	11.86
CAT-M1 eFDD 12 QPSK	mid	3	5	21.82	3 (ERP)	3 (ERP)	12.95	12.95
CAT-M1 eFDD 12 QPSK	mid	6	5	21.92	3 (ERP)	3 (ERP)	12.85	12.85
CAT-M1 eFDD 12 16QAM	mid	1	5	22.58	3 (ERP)	3 (ERP)	12.19	12.19
CAT-M1 eFDD 12 16QAM	mid	5	5	21.03	3 (ERP)	3 (ERP)	13.74	13.74
CAT-M1 eFDD 12 QPSK	mid	1	10	22.98	3 (ERP)	3 (ERP)	11.79	11.79
CAT-M1 eFDD 12 QPSK	mid	3	10	22.79	3 (ERP)	3 (ERP)	11.98	11.98
CAT-M1 eFDD 12 QPSK	mid	6	10	21.91	3 (ERP)	3 (ERP)	12.86	12.86
CAT-M1 eFDD 12 16QAM	mid	1	10	22.66	3 (ERP)	3 (ERP)	12.11	12.11
CAT-M1 eFDD 12 16QAM	mid	5	10	22.12	3 (ERP)	3 (ERP)	12.65	12.65
CAT-M1 eFDD 13 QPSK	mid	1	5	22.80	3 (ERP)	3 (ERP)	11.97	11.97
CAT-M1 eFDD 13 QPSK	mid	3	5	21.69	3 (ERP)	3 (ERP)	13.08	13.08
CAT-M1 eFDD 13 QPSK	mid	6	5	21.76	3 (ERP)	3 (ERP)	13.01	13.01
CAT-M1 eFDD 13 16QAM	mid	1	5	22.39	3 (ERP)	3 (ERP)	12.38	12.38
CAT-M1 eFDD 13 16QAM	mid	5	5	21.01	3 (ERP)	3 (ERP)	13.76	13.76
CAT-M1 eFDD 13 QPSK	mid	1	10	21.92	3 (ERP)	3 (ERP)	12.85	12.85
CAT-M1 eFDD 13 QPSK	mid	3	10	22.83	3 (ERP)	3 (ERP)	11.94	11.94
CAT-M1 eFDD 13 QPSK	mid	6	10	20.98	3 (ERP)	3 (ERP)	13.79	13.79
CAT-M1 eFDD 13 16QAM	mid	1	10	22.39	3 (ERP)	3 (ERP)	12.38	12.38
CAT-M1 eFDD 13 16QAM	mid	5	10	21.01	3 (ERP)	3 (ERP)	13.76	13.76
CAT-M1 eFDD 66 QPSK	low	1	1.4	23.37	1 (EIRP)	1 (EIRP)	6.63	6.63
CAT-M1 eFDD 66 QPSK	low	3	1.4	22.29	1 (EIRP)	1 (EIRP)	7.71	7.71
CAT-M1 eFDD 66 QPSK	low	6	1.4	21.40	1 (EIRP)	1 (EIRP)	8.6	8.6
CAT-M1 eFDD 66 QPSK	mid	1	1.4	23.79	1 (EIRP)	1 (EIRP)	6.21	6.21
CAT-M1 eFDD 66 QPSK	mid	3	1.4	22.47	1 (EIRP)	1 (EIRP)	7.53	7.53
CAT-M1 eFDD 66 QPSK	mid	6	1.4	21.62	1 (EIRP)	1 (EIRP)	8.38	8.38
CAT-M1 eFDD 66 QPSK	high	1	1.4	23.77	1 (EIRP)	1 (EIRP)	6.23	6.23
CAT-M1 eFDD 66 QPSK	high	3	1.4	22.45	1 (EIRP)	1 (EIRP)	7.55	7.55
CAT-M1 eFDD 66 QPSK	high	6	1.4	21.58	1 (EIRP)	1 (EIRP)	8.42	8.42
CAT-M1 eFDD 66 16QAM	low	1	1.4	21.85	1 (EIRP)	1 (EIRP)	8.15	8.15
CAT-M1 eFDD 66 16QAM	low	5	1.4	21.56	1 (EIRP)	1 (EIRP)	8.44	8.44
CAT-M1 eFDD 66 16QAM	mid	1	1.4	22.20	1 (EIRP)	1 (EIRP)	7.8	7.8
CAT-M1 eFDD 66 16QAM	mid	5	1.4	21.78	1 (EIRP)	1 (EIRP)	8.22	8.22
CAT-M1 eFDD 66 16QAM	high	1	1.4	22.12	1 (EIRP)	1 (EIRP)	7.88	7.88
CAT-M1 eFDD 66 16QAM	high	5	1.4	21.74	1 (EIRP)	1 (EIRP)	8.26	8.26
CAT-M1 eFDD 66 QPSK	low	1	3	23.45	1 (EIRP)	1 (EIRP)	6.55	6.55
CAT-M1 eFDD 66 QPSK	low	3	3	22.41	1 (EIRP)	1 (EIRP)	7.59	7.59
CAT-M1 eFDD 66 QPSK	low	6	3	21.49	1 (EIRP)	1 (EIRP)	8.51	8.51
CAT-M1 eFDD 66 QPSK	mid	1	3	23.62	1 (EIRP)	1 (EIRP)	6.38	6.38
CAT-M1 eFDD 66 QPSK	mid	3	3	22.37	1 (EIRP)	1 (EIRP)	7.63	7.63
CAT-M1 eFDD 66 QPSK	mid	6	3	21.57	1 (EIRP)	1 (EIRP)	8.43	8.43
CAT-M1 eFDD 66 QPSK	high	1	3	23.64	1 (EIRP)	1 (EIRP)	6.36	6.36
CAT-M1 eFDD 66 QPSK	high	3	3	22.40	1 (EIRP)	1 (EIRP)	7.6	7.6
CAT-M1 eFDD 66 QPSK	high	6	3	21.61	1 (EIRP)	1 (EIRP)	8.39	8.39
CAT-M1 eFDD 66 16QAM	low	1	3	22.03	1 (EIRP)	1 (EIRP)	7.97	7.97
CAT-M1 eFDD 66 16QAM	low	5	3	22.36	1 (EIRP)	1 (EIRP)	7.64	7.64
CAT-M1 eFDD 66 16QAM	mid	1	3	22.00	1 (EIRP)	1 (EIRP)	8	8
CAT-M1 eFDD 66 16QAM	mid	5	3	21.74	1 (EIRP)	1 (EIRP)	8.26	8.26
CAT-M1 eFDD 66 16QAM	high	1	3	22.04	1 (EIRP)	1 (EIRP)	7.96	7.96
CAT-M1 eFDD 66 16QAM	high	5	3	21.74	1 (EIRP)	1 (EIRP)	8.26	8.26
CAT-M1 eFDD 66 QPSK	low	1	5	23.40	1 (EIRP)	1 (EIRP)	6.6	6.6
CAT-M1 eFDD 66 QPSK	low	3	5	22.35	1 (EIRP)	1 (EIRP)	7.65	7.65
CAT-M1 eFDD 66 QPSK	low	6	5	22.31	1 (EIRP)	1 (EIRP)	7.69	7.69

CAT-M1 eFDD 66 QPSK	mid	1	5	23.65	1 (EIRP)	1 (EIRP)	6.35	6.35
CAT-M1 eFDD 66 QPSK	mid	3	5	22.40	1 (EIRP)	1 (EIRP)	7.6	7.6
CAT-M1 eFDD 66 QPSK	mid	6	5	22.52	1 (EIRP)	1 (EIRP)	7.48	7.48
CAT-M1 eFDD 66 QPSK	high	1	5	22.91	1 (EIRP)	1 (EIRP)	7.09	7.09
CAT-M1 eFDD 66 QPSK	high	3	5	22.07	1 (EIRP)	1 (EIRP)	7.93	7.93
CAT-M1 eFDD 66 QPSK	high	6	5	22.16	1 (EIRP)	1 (EIRP)	7.84	7.84
CAT-M1 eFDD 66 16QAM	low	1	5	23.02	1 (EIRP)	1 (EIRP)	6.98	6.98
CAT-M1 eFDD 66 16QAM	low	5	5	22.32	1 (EIRP)	1 (EIRP)	7.68	7.68
CAT-M1 eFDD 66 16QAM	mid	1	5	23.21	1 (EIRP)	1 (EIRP)	6.79	6.79
CAT-M1 eFDD 66 16QAM	mid	5	5	21.76	1 (EIRP)	1 (EIRP)	8.24	8.24
CAT-M1 eFDD 66 16QAM	high	1	5	23.36	1 (EIRP)	1 (EIRP)	6.64	6.64
CAT-M1 eFDD 66 16QAM	high	5	5	21.42	1 (EIRP)	1 (EIRP)	8.58	8.58
CAT-M1 eFDD 66 QPSK	low	1	10	21.27	1 (EIRP)	1 (EIRP)	8.73	8.73
CAT-M1 eFDD 66 QPSK	low	3	10	23.28	1 (EIRP)	1 (EIRP)	6.72	6.72
CAT-M1 eFDD 66 QPSK	low	6	10	22.45	1 (EIRP)	1 (EIRP)	7.55	7.55
CAT-M1 eFDD 66 QPSK	mid	1	10	23.61	1 (EIRP)	1 (EIRP)	6.39	6.39
CAT-M1 eFDD 66 QPSK	mid	3	10	23.56	1 (EIRP)	1 (EIRP)	6.44	6.44
CAT-M1 eFDD 66 QPSK	mid	6	10	22.48	1 (EIRP)	1 (EIRP)	7.52	7.52
CAT-M1 eFDD 66 QPSK	high	1	10	22.71	1 (EIRP)	1 (EIRP)	7.29	7.29
CAT-M1 eFDD 66 QPSK	high	3	10	23.28	1 (EIRP)	1 (EIRP)	6.72	6.72
CAT-M1 eFDD 66 QPSK	high	6	10	22.20	1 (EIRP)	1 (EIRP)	7.8	7.8
CAT-M1 eFDD 66 16QAM	low	1	10	22.95	1 (EIRP)	1 (EIRP)	7.05	7.05
CAT-M1 eFDD 66 16QAM	low	5	10	22.62	1 (EIRP)	1 (EIRP)	7.38	7.38
CAT-M1 eFDD 66 16QAM	mid	1	10	23.33	1 (EIRP)	1 (EIRP)	6.67	6.67
CAT-M1 eFDD 66 16QAM	mid	5	10	22.62	1 (EIRP)	1 (EIRP)	7.38	7.38
CAT-M1 eFDD 66 16QAM	high	1	10	23.55	1 (EIRP)	1 (EIRP)	6.45	6.45
CAT-M1 eFDD 66 16QAM	high	5	10	22.34	1 (EIRP)	1 (EIRP)	7.66	7.66
CAT-M1 eFDD 71 QPSK	low	1	5	22.63	3 (ERP)	3 (ERP)	12.14	12.14
CAT-M1 eFDD 71 QPSK	low	3	5	21.48	3 (ERP)	3 (ERP)	13.29	13.29
CAT-M1 eFDD 71 QPSK	low	6	5	21.53	3 (ERP)	3 (ERP)	13.24	13.24
CAT-M1 eFDD 71 QPSK	mid	1	5	22.83	3 (ERP)	3 (ERP)	11.94	11.94
CAT-M1 eFDD 71 QPSK	mid	3	5	21.65	3 (ERP)	3 (ERP)	13.12	13.12
CAT-M1 eFDD 71 QPSK	mid	6	5	21.74	3 (ERP)	3 (ERP)	13.03	13.03
CAT-M1 eFDD 71 QPSK	high	1	5	22.73	3 (ERP)	3 (ERP)	12.04	12.04
CAT-M1 eFDD 71 QPSK	high	3	5	21.65	3 (ERP)	3 (ERP)	13.12	13.12
CAT-M1 eFDD 71 QPSK	high	6	5	21.74	3 (ERP)	3 (ERP)	13.03	13.03
CAT-M1 eFDD 71 16QAM	low	1	5	22.18	3 (ERP)	3 (ERP)	12.59	12.59
CAT-M1 eFDD 71 16QAM	low	5	5	21.49	3 (ERP)	3 (ERP)	13.28	13.28
CAT-M1 eFDD 71 16QAM	mid	1	5	22.40	3 (ERP)	3 (ERP)	12.37	12.37
CAT-M1 eFDD 71 16QAM	mid	5	5	20.96	3 (ERP)	3 (ERP)	13.81	13.81
CAT-M1 eFDD 71 16QAM	high	1	5	22.33	3 (ERP)	3 (ERP)	12.44	12.44
CAT-M1 eFDD 71 16QAM	high	5	5	20.94	3 (ERP)	3 (ERP)	13.83	13.83
CAT-M1 eFDD 71 QPSK	low	1	10	22.66	3 (ERP)	3 (ERP)	12.11	12.11
CAT-M1 eFDD 71 QPSK	low	3	10	22.28	3 (ERP)	3 (ERP)	12.49	12.49
CAT-M1 eFDD 71 QPSK	low	6	10	21.52	3 (ERP)	3 (ERP)	13.25	13.25
CAT-M1 eFDD 71 QPSK	mid	1	10	22.75	3 (ERP)	3 (ERP)	12.02	12.02
CAT-M1 eFDD 71 QPSK	mid	3	10	22.60	3 (ERP)	3 (ERP)	12.17	12.17
CAT-M1 eFDD 71 QPSK	mid	6	10	21.68	3 (ERP)	3 (ERP)	13.09	13.09
CAT-M1 eFDD 71 QPSK	high	1	10	22.89	3 (ERP)	3 (ERP)	11.88	11.88
CAT-M1 eFDD 71 QPSK	high	3	10	22.37	3 (ERP)	3 (ERP)	12.4	12.4
CAT-M1 eFDD 71 QPSK	high	6	10	21.68	3 (ERP)	3 (ERP)	13.09	13.09
CAT-M1 eFDD 71 16QAM	low	1	10	22.36	3 (ERP)	3 (ERP)	12.41	12.41
CAT-M1 eFDD 71 16QAM	low	5	10	21.71	3 (ERP)	3 (ERP)	13.06	13.06
CAT-M1 eFDD 71 16QAM	mid	1	10	22.36	3 (ERP)	3 (ERP)	12.41	12.41
CAT-M1 eFDD 71 16QAM	mid	5	10	21.91	3 (ERP)	3 (ERP)	12.86	12.86
CAT-M1 eFDD 71 16QAM	high	1	10	22.43	3 (ERP)	3 (ERP)	12.34	12.34
CAT-M1 eFDD 71 16QAM	high	5	10	21.89	3 (ERP)	3 (ERP)	12.88	12.88
NB-IoT eFDD 4 QPSK	low	1	0.2	22.15	1 (EIRP)	1 (EIRP)	7.85	7.85
NB-IoT eFDD 4 QPSK	low	3	0.2	22.11	1 (EIRP)	1 (EIRP)	7.89	7.89
NB-IoT eFDD 4 QPSK	low	6	0.2	22.38	1 (EIRP)	1 (EIRP)	7.62	7.62
NB-IoT eFDD 4 QPSK	low	12	0.2	21.13	1 (EIRP)	1 (EIRP)	8.87	8.87
NB-IoT eFDD 4 QPSK	mid	1	0.2	22.77	1 (EIRP)	1 (EIRP)	7.23	7.23
NB-IoT eFDD 4 QPSK	mid	3	0.2	22.22	1 (EIRP)	1 (EIRP)	7.78	7.78
NB-IoT eFDD 4 QPSK	mid	6	0.2	22.52	1 (EIRP)	1 (EIRP)	7.48	7.48

NB-IoT eFDD 4 QPSK	mid	12	0.2	21.54	1 (EIRP)	1 (EIRP)	8.46	8.46
NB-IoT eFDD 4 QPSK	high	1	0.2	22.81	1 (EIRP)	1 (EIRP)	7.19	7.19
NB-IoT eFDD 4 QPSK	high	3	0.2	22.27	1 (EIRP)	1 (EIRP)	7.73	7.73
NB-IoT eFDD 4 QPSK	high	6	0.2	22.62	1 (EIRP)	1 (EIRP)	7.38	7.38
NB-IoT eFDD 4 QPSK	high	12	0.2	21.63	1 (EIRP)	1 (EIRP)	8.37	8.37
NB-IoT eFDD 4 BPSK	low	1	0.2	22.64	1 (EIRP)	1 (EIRP)	7.36	7.36
NB-IoT eFDD 4 BPSK	mid	1	0.2	22.82	1 (EIRP)	1 (EIRP)	7.18	7.18
NB-IoT eFDD 4 BPSK	high	1	0.2	22.79	1 (EIRP)	1 (EIRP)	7.21	7.21
NB-IoT eFDD 12 QPSK	low	1	0.2	23.36	3 (ERP)	3 (ERP)	11.41	11.41
NB-IoT eFDD 12 QPSK	low	3	0.2	23.18	3 (ERP)	3 (ERP)	11.59	11.59
NB-IoT eFDD 12 QPSK	low	6	0.2	23.51	3 (ERP)	3 (ERP)	11.26	11.26
NB-IoT eFDD 12 QPSK	low	12	0.2	22.16	3 (ERP)	3 (ERP)	12.61	12.61
NB-IoT eFDD 12 QPSK	mid	1	0.2	23.25	3 (ERP)	3 (ERP)	11.52	11.52
NB-IoT eFDD 12 QPSK	mid	3	0.2	23.06	3 (ERP)	3 (ERP)	11.71	11.71
NB-IoT eFDD 12 QPSK	mid	6	0.2	23.39	3 (ERP)	3 (ERP)	11.38	11.38
NB-IoT eFDD 12 QPSK	mid	12	0.2	22.05	3 (ERP)	3 (ERP)	12.72	12.72
NB-IoT eFDD 12 QPSK	high	1	0.2	23.13	3 (ERP)	3 (ERP)	11.64	11.64
NB-IoT eFDD 12 QPSK	high	3	0.2	22.90	3 (ERP)	3 (ERP)	11.87	11.87
NB-IoT eFDD 12 QPSK	high	6	0.2	23.21	3 (ERP)	3 (ERP)	11.56	11.56
NB-IoT eFDD 12 QPSK	high	12	0.2	22.00	3 (ERP)	3 (ERP)	12.77	12.77
NB-IoT eFDD 12 BPSK	low	1	0.2	23.30	3 (ERP)	3 (ERP)	11.47	11.47
NB-IoT eFDD 12 BPSK	mid	1	0.2	23.22	3 (ERP)	3 (ERP)	11.55	11.55
NB-IoT eFDD 12 BPSK	high	1	0.2	23.11	3 (ERP)	3 (ERP)	11.66	11.66
NB-IoT eFDD 13 QPSK	low	1	0.2	23.12	3 (ERP)	3 (ERP)	11.65	11.65
NB-IoT eFDD 13 QPSK	low	3	0.2	22.84	3 (ERP)	3 (ERP)	11.93	11.93
NB-IoT eFDD 13 QPSK	low	6	0.2	23.15	3 (ERP)	3 (ERP)	11.62	11.62
NB-IoT eFDD 13 QPSK	low	12	0.2	22.03	3 (ERP)	3 (ERP)	12.74	12.74
NB-IoT eFDD 13 QPSK	mid	1	0.2	23.28	3 (ERP)	3 (ERP)	11.49	11.49
NB-IoT eFDD 13 QPSK	mid	3	0.2	23.01	3 (ERP)	3 (ERP)	11.76	11.76
NB-IoT eFDD 13 QPSK	mid	6	0.2	23.30	3 (ERP)	3 (ERP)	11.47	11.47
NB-IoT eFDD 13 QPSK	mid	12	0.2	22.19	3 (ERP)	3 (ERP)	12.58	12.58
NB-IoT eFDD 13 QPSK	high	1	0.2	23.28	3 (ERP)	3 (ERP)	11.49	11.49
NB-IoT eFDD 13 QPSK	high	3	0.2	23.03	3 (ERP)	3 (ERP)	11.74	11.74
NB-IoT eFDD 13 QPSK	high	6	0.2	23.32	3 (ERP)	3 (ERP)	11.45	11.45
NB-IoT eFDD 13 QPSK	high	12	0.2	22.16	3 (ERP)	3 (ERP)	12.61	12.61
NB-IoT eFDD 13 BPSK	low	1	0.2	23.11	3 (ERP)	3 (ERP)	11.66	11.66
NB-IoT eFDD 13 BPSK	mid	1	0.2	23.27	3 (ERP)	3 (ERP)	11.5	11.5
NB-IoT eFDD 13 BPSK	high	1	0.2	23.26	3 (ERP)	3 (ERP)	11.65	11.65
NB-IoT eFDD 8 QPSK	low	1	0.2	22.76	3 (ERP)	-	12.01	-
NB-IoT eFDD 8 QPSK	low	3	0.2	22.49	3 (ERP)	-	12.28	-
NB-IoT eFDD 8 QPSK	low	6	0.2	22.76	3 (ERP)	-	12.01	-
NB-IoT eFDD 8 QPSK	low	12	0.2	21.07	3 (ERP)	-	13.7	-
NB-IoT eFDD 8 QPSK	mid	1	0.2	22.74	3 (ERP)	-	12.03	-
NB-IoT eFDD 8 QPSK	mid	3	0.2	22.49	3 (ERP)	-	12.28	-
NB-IoT eFDD 8 QPSK	mid	6	0.2	22.77	3 (ERP)	-	12.00	-
NB-IoT eFDD 8 QPSK	mid	12	0.2	21.01	3 (ERP)	-	13.76	-
NB-IoT eFDD 8 QPSK	high	1	0.2	22.73	3 (ERP)	-	12.04	-
NB-IoT eFDD 8 QPSK	high	3	0.2	22.51	3 (ERP)	-	12.26	-
NB-IoT eFDD 8 QPSK	high	6	0.2	22.77	3 (ERP)	-	12.00	-
NB-IoT eFDD 8 QPSK	high	12	0.2	20.98	3 (ERP)	-	13.79	-
NB-IoT eFDD 8 BPSK	low	1	0.2	22.69	3 (ERP)	-	12.08	-
NB-IoT eFDD 8 BPSK	mid	1	0.2	22.72	3 (ERP)	-	12.05	-
NB-IoT eFDD 8 BPSK	high	1	0.2	22.70	3 (ERP)	-	12.07	-
NB-IoT eFDD 66 QPSK	low	1	0.2	22.60	1 (EIRP)	1 (EIRP)	7.40	7.40
NB-IoT eFDD 66 QPSK	low	3	0.2	22.18	1 (EIRP)	1 (EIRP)	7.82	7.82
NB-IoT eFDD 66 QPSK	low	6	0.2	22.46	1 (EIRP)	1 (EIRP)	7.54	7.54
NB-IoT eFDD 66 QPSK	low	12	0.2	21.45	1 (EIRP)	1 (EIRP)	8.55	8.55
NB-IoT eFDD 66 QPSK	mid	1	0.2	22.60	1 (EIRP)	1 (EIRP)	7.40	7.40
NB-IoT eFDD 66 QPSK	mid	3	0.2	22.20	1 (EIRP)	1 (EIRP)	7.80	7.80
NB-IoT eFDD 66 QPSK	mid	6	0.2	22.49	1 (EIRP)	1 (EIRP)	7.51	7.51
NB-IoT eFDD 66 QPSK	mid	12	0.2	21.49	1 (EIRP)	1 (EIRP)	8.51	8.51
NB-IoT eFDD 66 QPSK	high	1	0.2	22.61	1 (EIRP)	1 (EIRP)	7.39	7.39
NB-IoT eFDD 66 QPSK	high	3	0.2	22.32	1 (EIRP)	1 (EIRP)	7.68	7.68
NB-IoT eFDD 66 QPSK	high	6	0.2	22.60	1 (EIRP)	1 (EIRP)	7.40	7.40

NB-IoT eFDD 66 QPSK	high	12	0.2	21.58	1 (EIRP)	1 (EIRP)	8.42	8.42
NB-IoT eFDD 66 BPSK	low	1	0.2	22.57	1 (EIRP)	1 (EIRP)	7.43	7.43
NB-IoT eFDD 66 BPSK	mid	1	0.2	22.60	1 (EIRP)	1 (EIRP)	7.40	7.40
NB-IoT eFDD 66 BPSK	high	1	0.2	22.60	1 (EIRP)	1 (EIRP)	7.40	7.40
NB-IoT eFDD 71 QPSK	low	1	0.2	23.04	3 (ERP)	3 (ERP)	11.73	11.73
NB-IoT eFDD 71 QPSK	low	3	0.2	22.97	3 (ERP)	3 (ERP)	11.80	11.80
NB-IoT eFDD 71 QPSK	low	6	0.2	23.28	3 (ERP)	3 (ERP)	11.49	11.49
NB-IoT eFDD 71 QPSK	low	12	0.2	21.29	3 (ERP)	3 (ERP)	13.48	13.48
NB-IoT eFDD 71 QPSK	mid	1	0.2	23.08	3 (ERP)	3 (ERP)	11.69	11.69
NB-IoT eFDD 71 QPSK	mid	3	0.2	22.94	3 (ERP)	3 (ERP)	11.83	11.83
NB-IoT eFDD 71 QPSK	mid	6	0.2	23.28	3 (ERP)	3 (ERP)	11.49	11.49
NB-IoT eFDD 71 QPSK	mid	12	0.2	21.35	3 (ERP)	3 (ERP)	13.42	13.42
NB-IoT eFDD 71 QPSK	high	1	0.2	23.19	3 (ERP)	3 (ERP)	11.58	11.58
NB-IoT eFDD 71 QPSK	high	3	0.2	22.93	3 (ERP)	3 (ERP)	11.84	11.84
NB-IoT eFDD 71 QPSK	high	6	0.2	23.26	3 (ERP)	3 (ERP)	11.51	11.51
NB-IoT eFDD 71 QPSK	high	12	0.2	21.25	3 (ERP)	3 (ERP)	13.52	13.52
NB-IoT eFDD 71 BPSK	low	1	0.2	22.98	3 (ERP)	3 (ERP)	11.79	11.79
NB-IoT eFDD 71 BPSK	mid	1	0.2	23.05	3 (ERP)	3 (ERP)	11.72	11.72
NB-IoT eFDD 71 BPSK	high	1	0.2	23.20	3 (ERP)	3 (ERP)	11.57	11.57
NB-IoT eFDD 85 QPSK	low	1	0.2	22.76	3 (ERP)	3 (ERP)	12.01	12.01
NB-IoT eFDD 85 QPSK	low	3	0.2	22.67	3 (ERP)	3 (ERP)	12.10	12.10
NB-IoT eFDD 85 QPSK	low	6	0.2	22.95	3 (ERP)	3 (ERP)	11.82	11.82
NB-IoT eFDD 85 QPSK	low	12	0.2	21.80	3 (ERP)	3 (ERP)	12.97	12.97
NB-IoT eFDD 85 QPSK	mid	1	0.2	22.71	3 (ERP)	3 (ERP)	12.06	12.06
NB-IoT eFDD 85 QPSK	mid	3	0.2	22.55	3 (ERP)	3 (ERP)	12.22	12.22
NB-IoT eFDD 85 QPSK	mid	6	0.2	22.91	3 (ERP)	3 (ERP)	11.86	11.86
NB-IoT eFDD 85 QPSK	mid	12	0.2	21.70	3 (ERP)	3 (ERP)	13.07	13.07
NB-IoT eFDD 85 QPSK	high	1	0.2	22.60	3 (ERP)	3 (ERP)	12.17	12.17
NB-IoT eFDD 85 QPSK	high	3	0.2	22.40	3 (ERP)	3 (ERP)	12.37	12.37
NB-IoT eFDD 85 QPSK	high	6	0.2	22.63	3 (ERP)	3 (ERP)	12.14	12.14
NB-IoT eFDD 85 QPSK	high	12	0.2	21.52	3 (ERP)	3 (ERP)	13.25	13.25
NB-IoT eFDD 85 BPSK	low	1	0.2	22.68	3 (ERP)	3 (ERP)	12.09	12.09
NB-IoT eFDD 85 BPSK	mid	1	0.2	22.62	3 (ERP)	3 (ERP)	12.15	12.15
NB-IoT eFDD 85 BPSK	high	1	0.2	22.53	3 (ERP)	3 (ERP)	12.24	12.24

Remark: Please see next sub-clause for the measurement plot.

5.15.4 MEASUREMENT PLOT (EXAMPLE PLOT, SHOWING WORST CASE, IF APPLICABLE)

CAT-M1 eFDD4 QPSK 1.4MHz RB1, Channel = mid

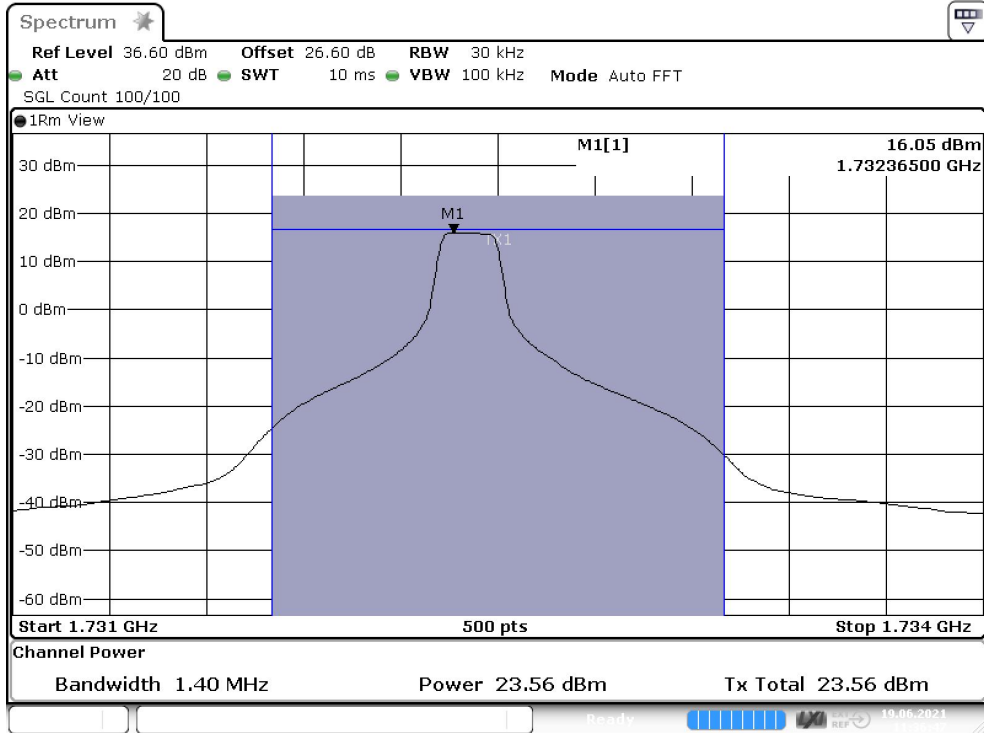

Date: 19.JUN.2021 11:36:47

CAT-M1 eFDD8 QPSK 1.4MHz RB1, Channel = low

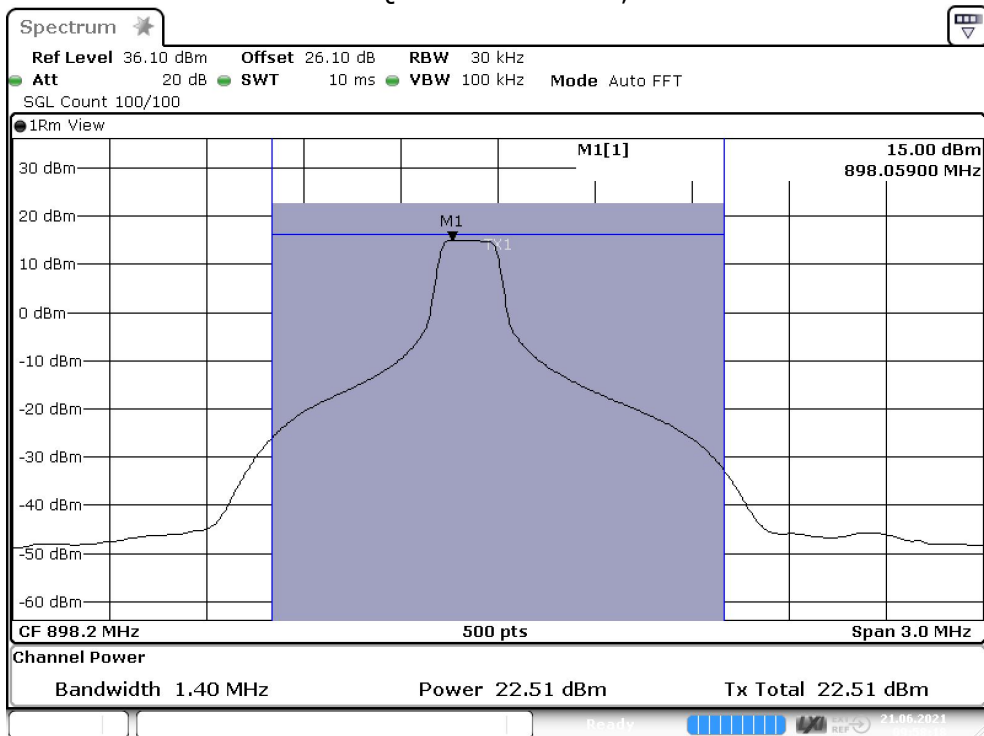

Date: 21.JUN.2021 09:58:19

CAT-M1 eFDD12 QPSK 1.4MHz RB1, Channel = mid

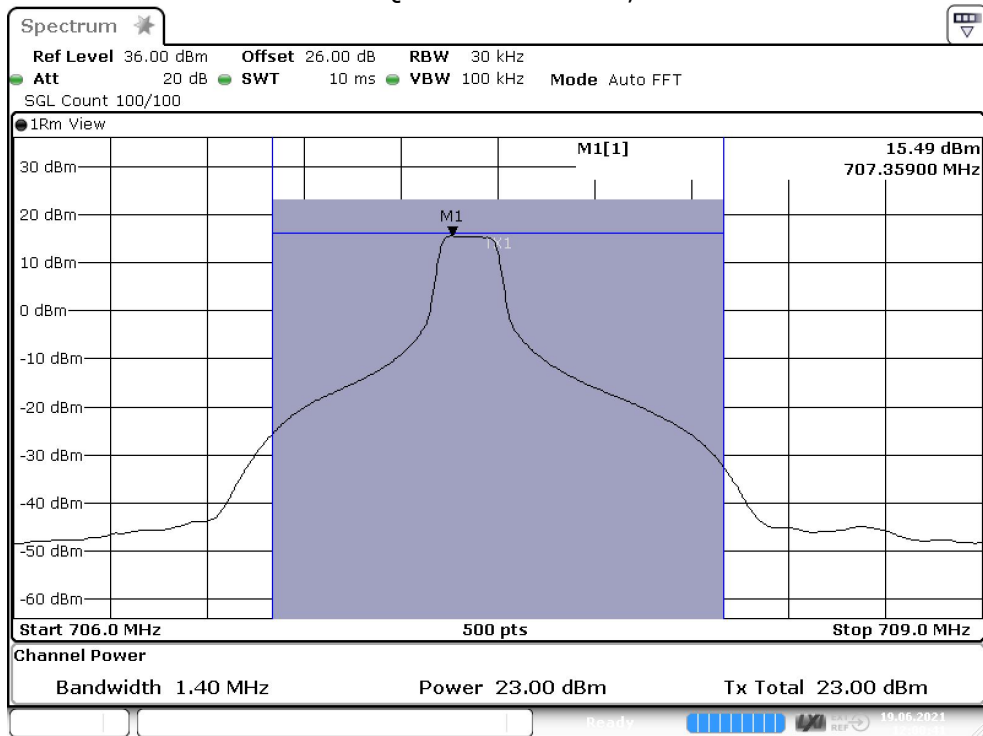

Date: 19 JUN 2021 12:00:41

CAT-M1 eFDD13 QPSK 5MHz RB1, Channel = mid

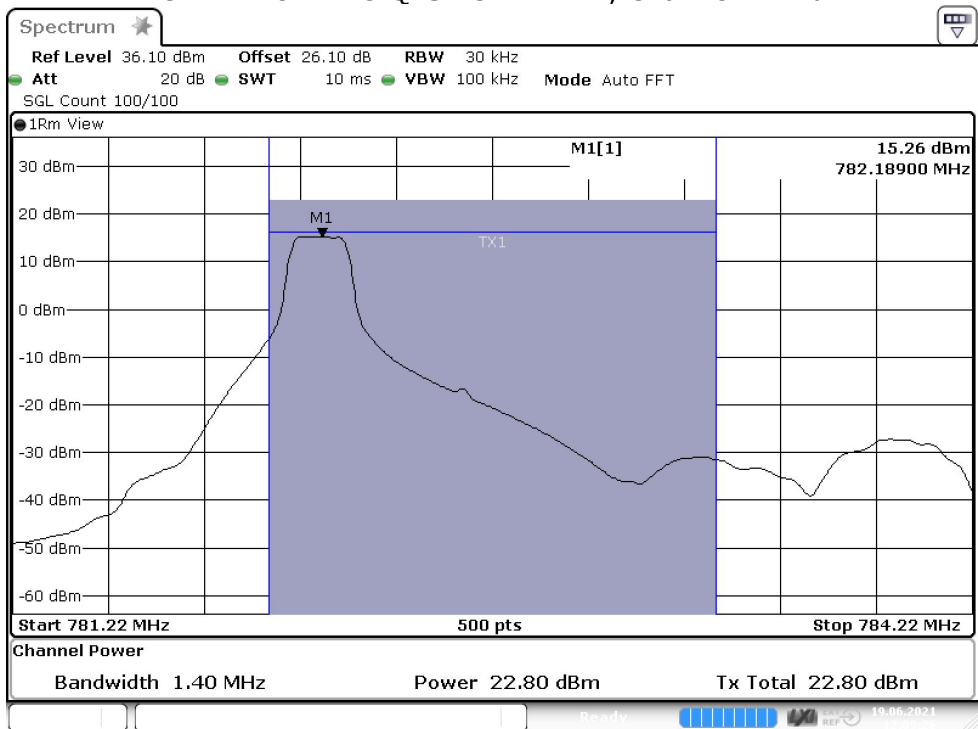

Date: 19 JUN 2021 12:09:26

CAT-M1 eFDD66 QPSK 5MHz RB1, Channel = mid

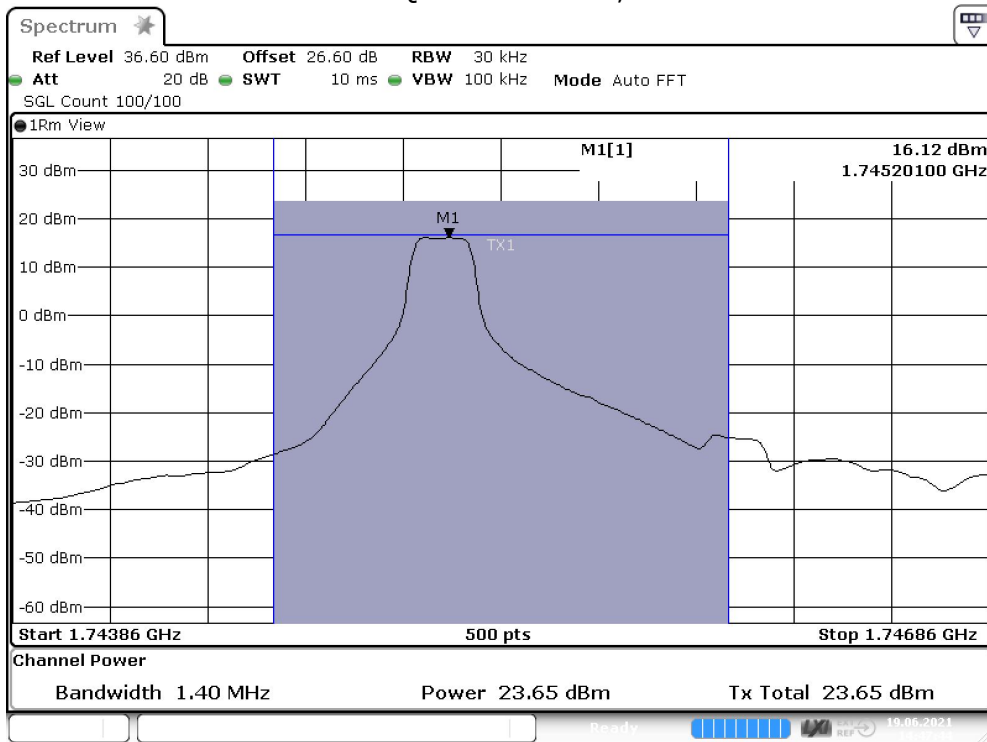

Date: 19.JUN.2021 14:47:44

CAT-M1 eFDD71 QPSK 10MHz RB1, Channel = high

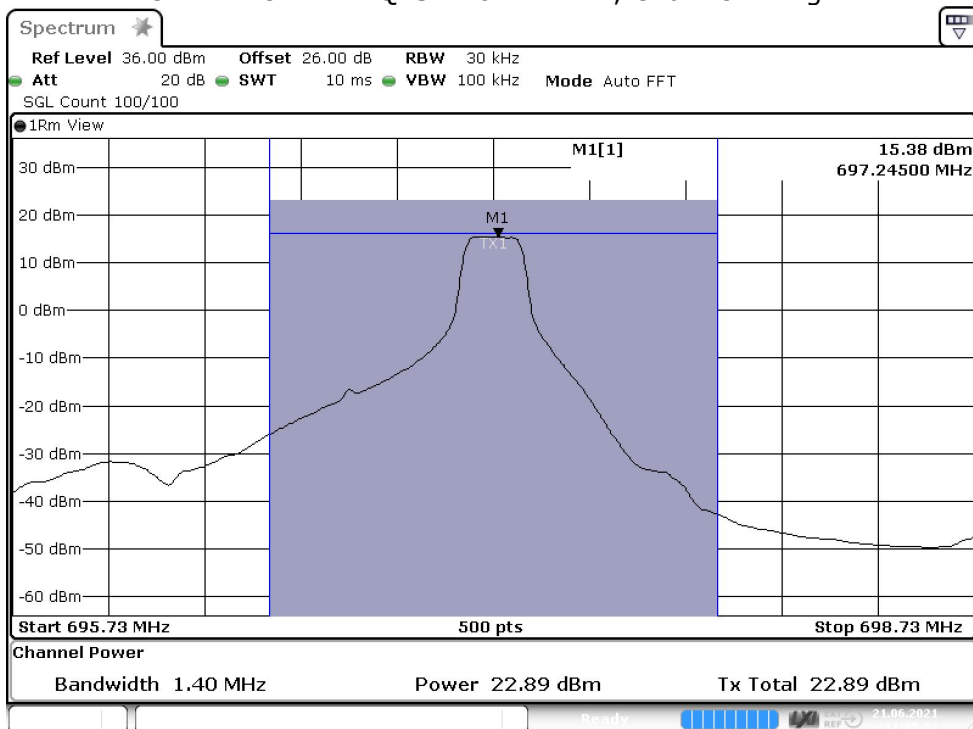

Date: 21.JUN.2021 11:35:52

NB-IoT eFDD4 QPSK SC1, Channel = high

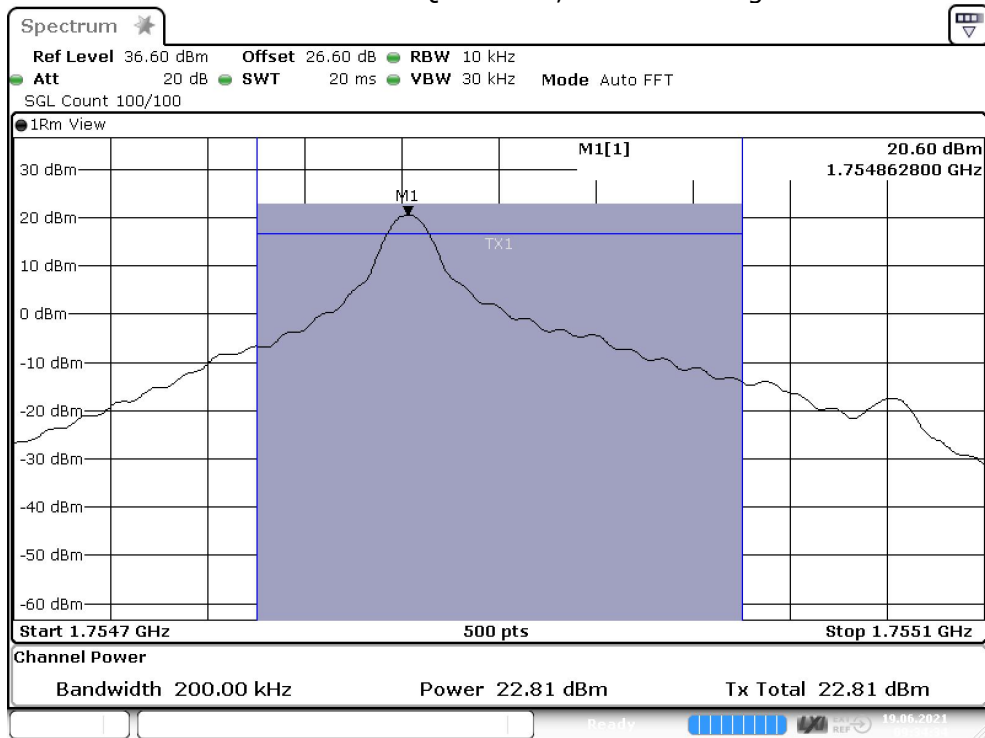

Date: 19.JUN.2021 09:34:35

NB-IoT eFDD8 QPSK SC6, Channel = mid

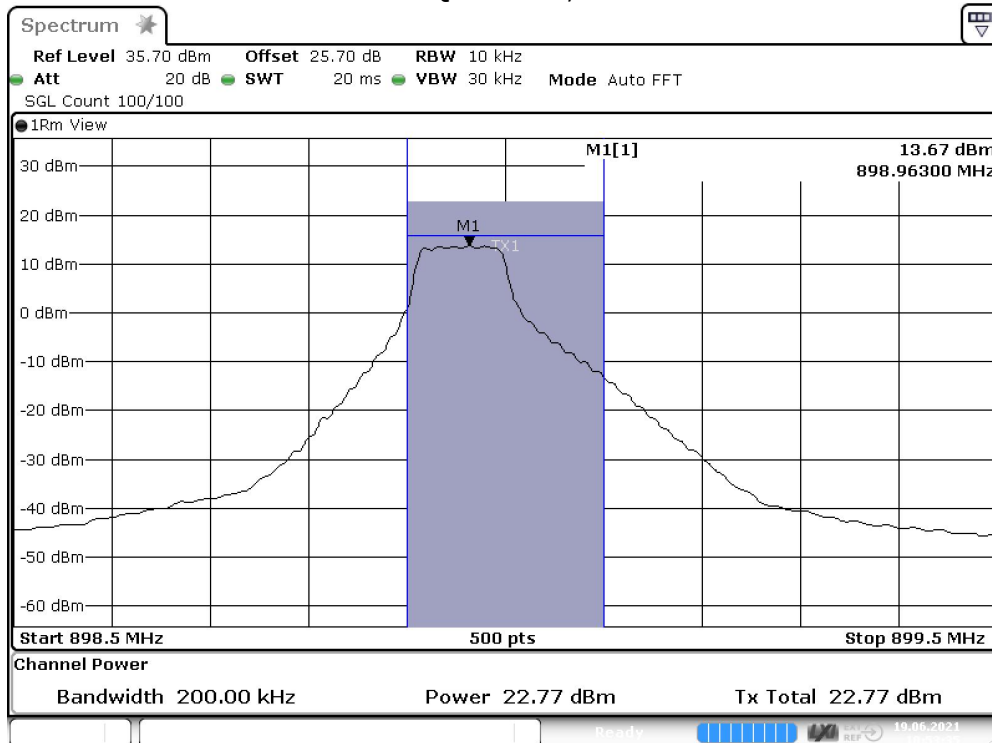

Date: 19.JUN.2021 10:53:35

NB-IoT eFDD12 QPSK SC6, Channel = low

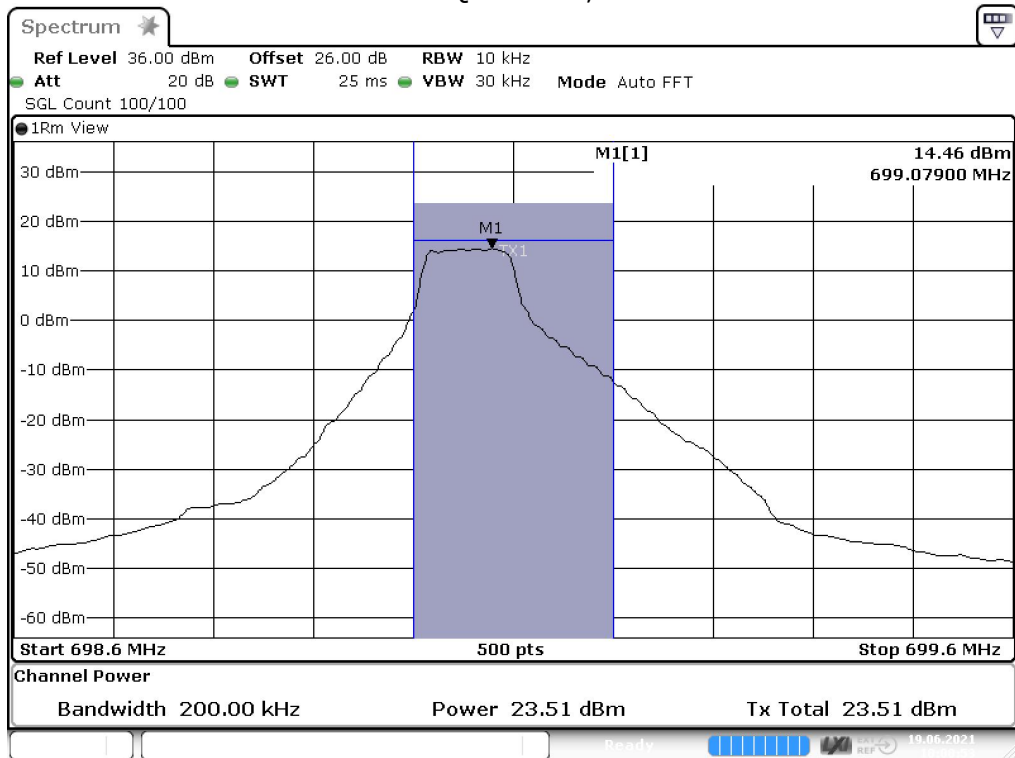

Date: 19.JUN.2021 10:00:53

NB-IoT eFDD13 QPSK SC6, Channel = high

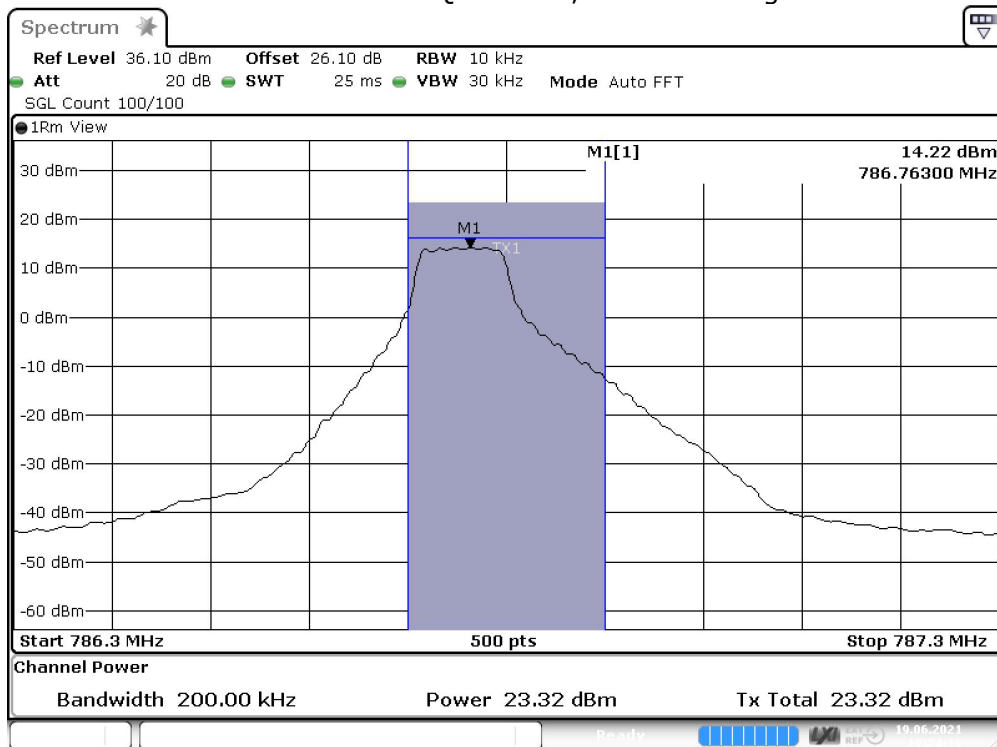

Date: 19.JUN.2021 10:24:15

NB-IoT eFDD66 QPSK SC1, Channel = high

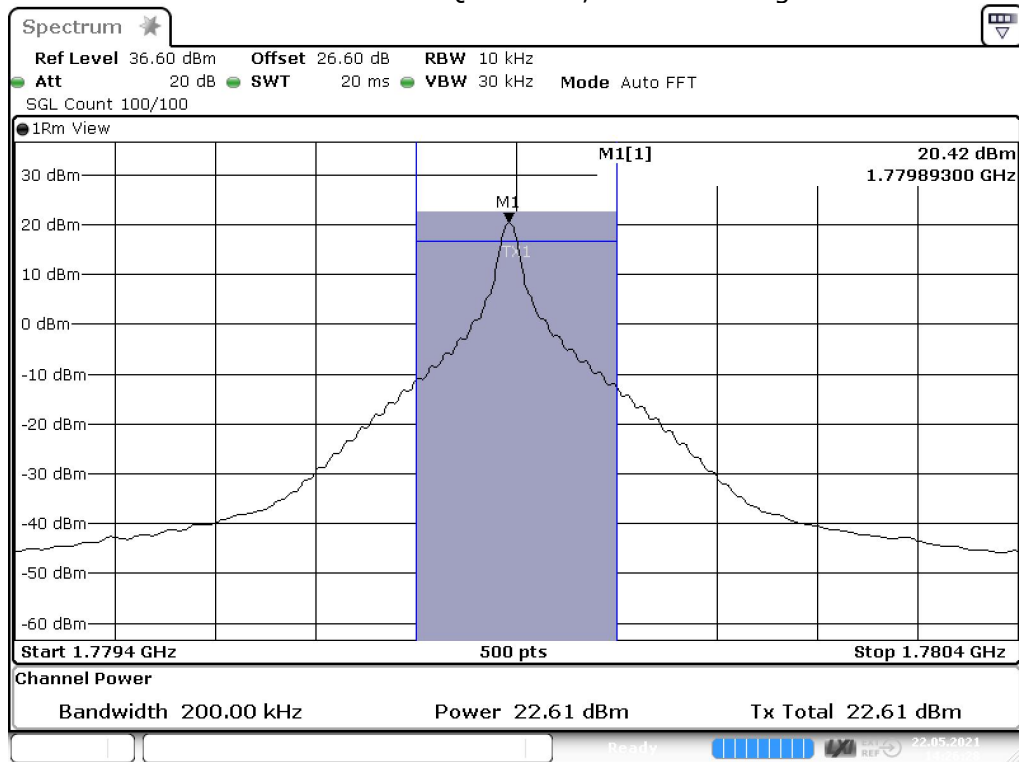

Date: 22.MAY.2021 14:26:28

NB-IoT eFDD71 QPSK SC6, Channel = mid

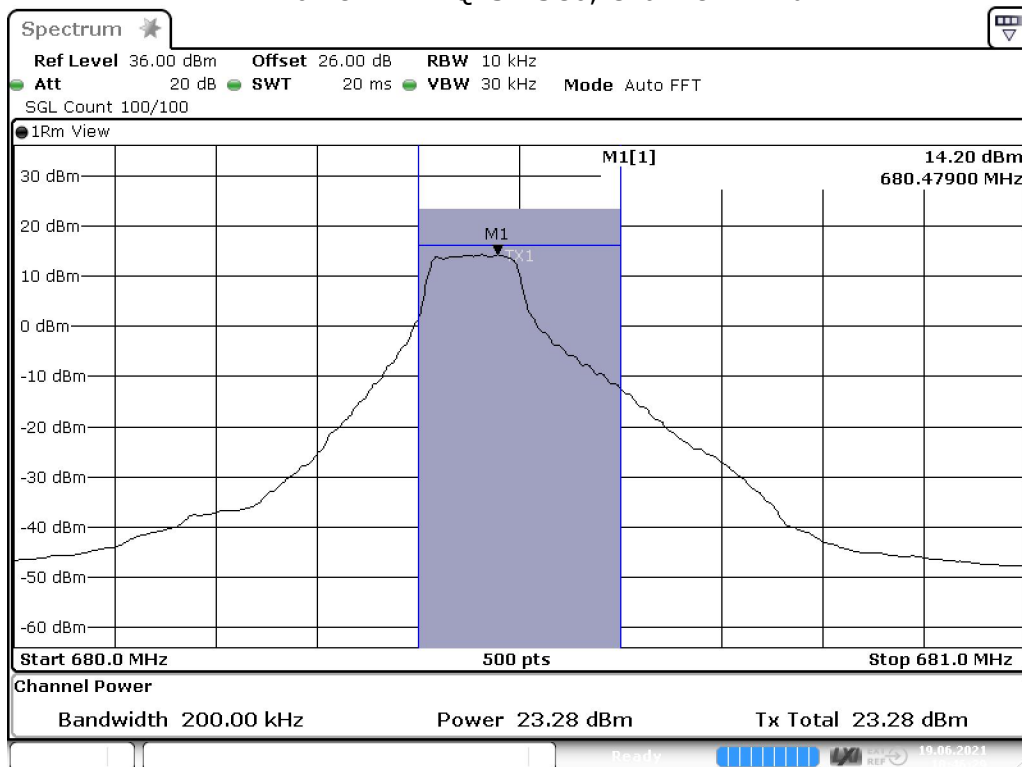

Date: 19.JUN.2021 10:46:29

NB-IoT eFDD85 QPSK SC6, Channel = low

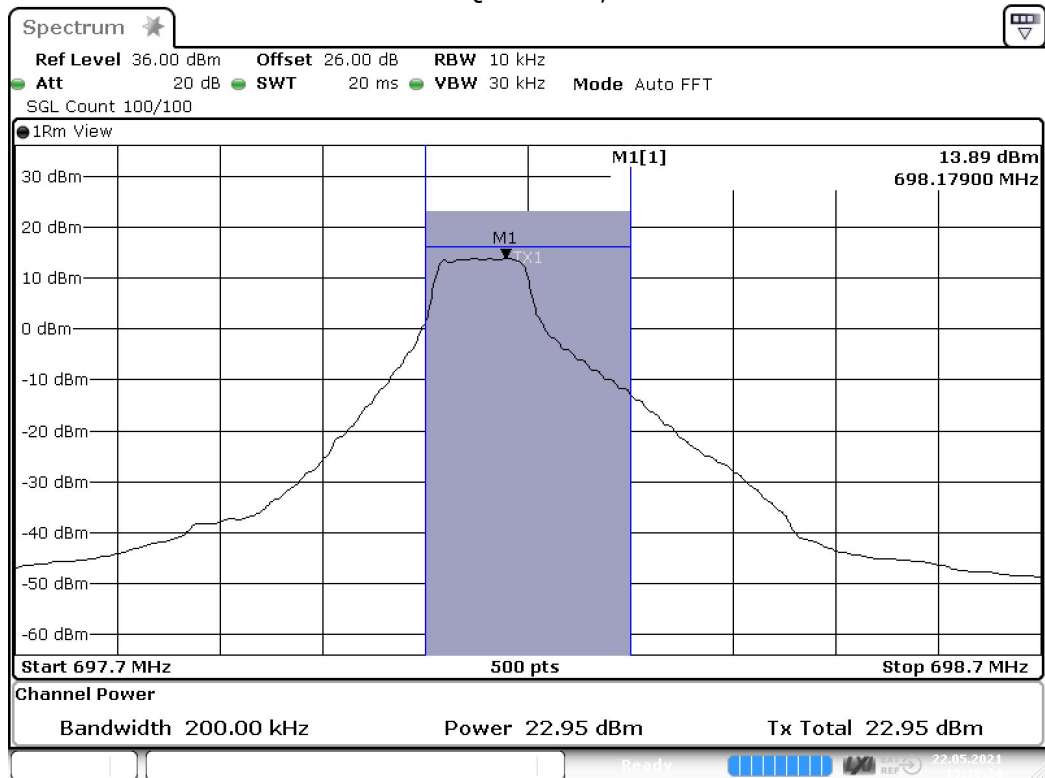

Date: 22.MAY.2021 15:18:24

5.15.5 TEST EQUIPMENT USED

- Radio Lab

5.16 FREQUENCY STABILITY

Standard **FCC PART 27 Subpart C**

The test was performed according to:
ANSI C63.26: 2015

5.16.1 TEST DESCRIPTION

This test case is intended to demonstrate compliance to the applicable frequency stability test case per § 2.1055 and RSS-GEN 6.11. The limit and the requirements come from the applicable rule part and ISED RSS-Standard for the operating band of the cellular device.

The EUT was connected to the test setup according to the following diagram:



Test Setup FCC Part 22/24/27/90 Cellular;
Frequency stability

The attenuation of the measuring / stimulus path is known for each measured frequency and are considered.

5.16.2 TEST REQUIREMENTS / LIMITS

FCC Part 27; Miscellaneous Wireless Communication Services

Subpart C – Technical standards

§ 27.54 - Frequency stability

All Bands

The frequency stability shall be sufficient to ensure that the fundamental emissions stay within the authorized bands of operation.

Band 12/13/17:

RSS-130; 4.5 Transmitter frequency stability

For equipment that is capable of transmitting numerous channels simultaneously for different applications (e.g. LTE and narrowband – Internet of Things (IoT)), the occupied bandwidth shall be the bandwidth representing the sum of the occupied bandwidths of these channels.

The frequency stability shall be sufficient to ensure that the occupied bandwidth remains within each frequency block range when tested at the temperature and supply voltage variations specified in RSS-Gen.

Band 4/10/66:

RSS-139; 6.4 Frequency Stability

The frequency stability shall be sufficient to ensure that the occupied bandwidth stays within the operating frequency block when tested to the temperature and supply voltage variations specified in RSS-Gen.

Band 7:

RSS-199; 4.3 Transmitter frequency stability

The transmitter frequency stability limit shall be determined as follows:

- a. the frequency offset shall be measured according to the procedure described in RSS-Gen and recorded.
- b. using a resolution bandwidth equal to that permitted within the 1 MHz band immediately outside the channel edge, as found in section 4.5, reference points will be selected at the unwanted emission limits, which comply with the attenuation specified in section 4.5 for the type of device under test, on the emission mask of the lowest and highest channels. The frequency at these points shall be recorded as fL and fH respectively.

The applicant shall ensure compliance with frequency stability requirements by showing that f_L minus the frequency offset and f_H plus the frequency offset is within the frequency range in which the equipment is designed to operate.

5.16.3 TEST PROTOCOL

CAT-M1 eFDD8

Temp. °C	Duration min	Voltage	Limit Hz	Freq. error Average (Hz)	Freq. error Max. (Hz)	Verdict
-30	0	normal	2243.75	-9	-12	passed
-30	5			-8	-11	passed
-30	10			-9	-11	passed
-20	0	normal	2243.75	-7	-12	passed
-20	5			-9	-12	passed
-20	10			-8	-11	passed
-10	0	normal	2243.75	-8	-11	passed
-10	5			-9	-13	passed
-10	10			-9	-13	passed
0	0	normal	2243.75	-4	-7	passed
0	5			-4	-8	passed
0	10			-6	-10	passed
10	0	normal	2243.75	-8	-16	passed
10	5			-7	-16	passed
10	10			-7	-14	passed
20	0	low	2243.75	-11	-18	passed
20	5			-9	-21	passed
20	10			-9	-19	passed
20	0	normal	2243.75	-8	-16	passed
20	5			-10	-24	passed
20	10			-6	-12	passed
20	0	high	2243.75	-11	-15	passed
20	5			-10	-15	passed
20	10			-9	-15	passed
30	0	normal	2243.75	-7	-12	passed
30	5			-11	-19	passed
30	10			-7	-14	passed
40	0	normal	2243.75	-4	-7	passed
40	5			-11	-19	passed
40	10			-9	-20	passed
50	0	normal	2243.75	-9	-12	passed
50	5			-10	-21	passed
50	10			-10	-17	passed

CAT-M1 eFDD66

Temp. °C	Duration min	Voltage	Limit Hz	Freq. error Average (Hz)	Freq. error Max. (Hz)	Verdict
-30	0	normal	4362.5	5	13	passed
-30	5			7	9	passed
-30	10			5	15	passed
-20	0	normal	4362.5	10	14	passed
-20	5			9	16	passed
-20	10			12	20	passed
-10	0	normal	4362.5	13	21	passed
-10	5			14	24	passed
-10	10			15	20	passed
0	0	normal	4362.5	16	21	passed
0	5			19	26	passed
0	10			17	27	passed
10	0	normal	4362.5	18	28	passed
10	5			18	27	passed
10	10			16	27	passed
20	0	low	4362.5	15	23	passed
20	5			14	25	passed
20	10			14	25	passed
20	0	normal	4362.5	12	20	passed
20	5			13	25	passed
20	10			11	22	passed
20	0	high	4362.5	19	27	passed
20	5			17	28	passed
20	10			17	31	passed
30	0	normal	4362.5	16	22	passed
30	5			14	24	passed
30	10			16	22	passed
40	0	normal	4362.5	17	21	passed
40	5			14	21	passed
40	10			14	22	passed
50	0	normal	4362.5	18	23	passed
50	5			16	21	passed
50	10			18	21	passed

CAT-M1 eFDD71

Temp. °C	Duration min	Voltage	Limit Hz	Freq. error Average (Hz)	Freq. error Max. (Hz)	Verdict
-30	0	normal	1701.25	-4	-10	passed
-30	5			-4	-8	passed
-30	10			-5	-7	passed
-20	0	normal	1701.25	-5	-8	passed
-20	5			-4	-8	passed
-20	10			-5	-11	passed
-10	0	normal	1701.25	-4	-7	passed
-10	5			-5	-7	passed
-10	10			-4	-9	passed
0	0	normal	1701.25	-5	-10	passed
0	5			-5	-9	passed
0	10			-4	-11	passed
10	0	normal	1701.25	-5	-9	passed
10	5			-6	-12	passed
10	10			-6	-12	passed
20	0	low	1701.25	-2	-8	passed
20	5			-3	-6	passed
20	10			-3	-6	passed
20	0	normal	1701.25	1	-4	passed
20	5			-1	-5	passed
20	10			-1	-5	passed
20	0	high	1701.25	-2	-7	passed
20	5			-1	-6	passed
20	10			-1	-4	passed
30	0	normal	1701.25	-1	-6	passed
30	5			0	8	passed
30	10			-2	-8	passed
40	0	normal	1701.25	1	-8	passed
40	5			-1	-7	passed
40	10			-1	7	passed
50	0	normal	1701.25	-1	-4	passed
50	5			1	-9	passed
50	10			-1	-9	passed

NB-IoT eFDD4

Temp. °C	Duration min	Voltage	Limit Hz	Freq. error Average (Hz)	Freq. error Max. (Hz)	Verdict
-30	0	normal	4331.25	0	5	passed
-30	5			0	3	passed
-30	10			1	7	passed
-20	0	normal	4331.25	1	5	passed
-20	5			1	6	passed
-20	10			0	6	passed
-10	0	normal	4331.25	1	4	passed
-10	5			1	8	passed
-10	10			2	7	passed
0	0	normal	4331.25	1	6	passed
0	5			1	7	passed
0	10			2	5	passed
10	0	normal	4331.25	2	9	passed
10	5			2	4	passed
10	10			1	7	passed
20	0	low	4331.25	2	9	passed
20	5			1	6	passed
20	10			2	4	passed
20	0	normal	4331.25	1	6	passed
20	5			0	4	passed
20	10			0	7	passed
20	0	high	4331.25	1	7	passed
20	5			1	7	passed
20	10			0	8	passed
30	0	normal	4331.25	1	3	passed
30	5			2	3	passed
30	10			0	5	passed
40	0	normal	4331.25	0	6	passed
40	5			1	7	passed
40	10			2	6	passed
50	0	normal	4331.25	1	7	passed
50	5			1	8	passed
50	10			0	5	passed

NB-IoT eFDD8

Temp. °C	Duration min	Voltage	Limit Hz	Freq. error Average (Hz)	Freq. error Max. (Hz)	Verdict
-30	0	normal	2091.25	2	9	passed
-30	5			3	11	passed
-30	10			-2	-6	passed
-20	0	normal	2091.25	-2	-8	passed
-20	5			3	7	passed
-20	10			-1	7	passed
-10	0	normal	2091.25	-3	8	passed
-10	5			-2	-10	passed
-10	10			0	-11	passed
0	0	normal	2091.25	0	-8	passed
0	5			3	-9	passed
0	10			2	10	passed
10	0	normal	2091.25	1	7	passed
10	5			1	5	passed
10	10			3	-11	passed
20	0	low	2091.25	-2	8	passed
20	5			1	7	passed
20	10			-2	-6	passed
20	0	normal	2091.25	-3	-6	passed
20	5			-2	8	passed
20	10			-2	7	passed
20	0	high	2091.25	2	8	passed
20	5			-2	-6	passed
20	10			3	7	passed
30	0	normal	2091.25	2	9	passed
30	5			3	6	passed
30	10			3	7	passed
40	0	normal	2091.25	-2	-8	passed
40	5			-1	4	passed
40	10			-1	-6	passed
50	0	normal	2091.25	4	10	passed
50	5			2	-9	passed
50	10			3	-8	passed

NB-IoT eFDD12

Temp. °C	Duration min	Voltage	Limit Hz	Freq. error Average (Hz)	Freq. error Max. (Hz)	Verdict
-30	0	normal	1768.75	3	14	passed
-30	5			6	21	passed
-30	10			4	16	passed
-20	0	normal	1768.75	5	18	passed
-20	5			4	20	passed
-20	10			6	13	passed
-10	0	normal	1768.75	6	16	passed
-10	5			5	19	passed
-10	10			3	20	passed
0	0	normal	1768.75	5	18	passed
0	5			4	15	passed
0	10			4	17	passed
10	0	normal	1768.75	6	14	passed
10	5			5	18	passed
10	10			3	15	passed
20	0	low	1768.75	6	12	passed
20	5			5	14	passed
20	10			5	18	passed
20	0	normal	1768.75	5	16	passed
20	5			4	17	passed
20	10			5	22	passed
20	0	high	1768.75	4	14	passed
20	5			6	18	passed
20	10			6	17	passed
30	0	normal	1768.75	4	18	passed
30	5			4	13	passed
30	10			6	15	passed
40	0	normal	1768.75	5	16	passed
40	5			6	16	passed
40	10			3	18	passed
50	0	normal	1768.75	4	19	passed
50	5			5	15	passed
50	10			6	14	passed

NB-IoT eFDD13

Temp. °C	Duration min	Voltage	Limit Hz	Freq. error Average (Hz)	Freq. error Max. (Hz)	Verdict
-30	0	normal	1955	-12	-22	passed
-30	5			-12	-23	passed
-30	10			-9	-18	passed
-20	0	normal	1955	-11	-19	passed
-20	5			-11	-19	passed
-20	10			-14	-31	passed
-10	0	normal	1955	-9	-17	passed
-10	5			-9	-18	passed
-10	10			-11	-21	passed
0	0	normal	1955	-6	-15	passed
0	5			-7	-14	passed
0	10			-5	-12	passed
10	0	normal	1955	-4	-9	passed
10	5			-4	-9	passed
10	10			-6	-12	passed
20	0	low	1955	-8	-16	passed
20	5			-6	-13	passed
20	10			-6	-14	passed
20	0	normal	1955	-9	-16	passed
20	5			-11	-19	passed
20	10			-12	-20	passed
20	0	high	1955	-8	-14	passed
20	5			-8	-15	passed
20	10			-12	-22	passed
30	0	normal	1955	-7	-14	passed
30	5			-9	-18	passed
30	10			-6	-15	passed
40	0	normal	1955	-12	-18	passed
40	5			-11	-21	passed
40	10			-11	-21	passed
50	0	normal	1955	-7	-12	passed
50	5			-11	-19	passed
50	10			-10	-21	passed

NB-IoT eFDD66

Temp. °C	Duration min	Voltage	Limit Hz	Freq. error Average (Hz)	Freq. error Max. (Hz)	Verdict
-30	0	normal	4362.5	-2	-15	passed
-30	5			-1	-17	passed
-30	10			-3	-13	passed
-20	0	normal	4362.5	-4	-15	passed
-20	5			-4	-17	passed
-20	10			-3	-18	passed
-10	0	normal	4362.5	-1	-17	passed
-10	5			-2	-13	passed
-10	10			-5	-22	passed
0	0	normal	4362.5	-6	-21	passed
0	5			-6	-22	passed
0	10			-4	-18	passed
10	0	normal	4362.5	-4	-19	passed
10	5			-1	-13	passed
10	10			-1	-12	passed
20	0	low	4362.5	-2	-18	passed
20	5			-4	-21	passed
20	10			-11	-18	passed
20	0	normal	4362.5	-6	-22	passed
20	5			-5	-19	passed
20	10			-9	-21	passed
20	0	high	4362.5	-8	-22	passed
20	5			-5	-20	passed
20	10			-4	-20	passed
30	0	normal	4362.5	-10	-18	passed
30	5			-10	-19	passed
30	10			-8	-23	passed
40	0	normal	4362.5	-9	-21	passed
40	5			-9	-25	passed
40	10			-11	-24	passed
50	0	normal	4362.5	-10	-27	passed
50	5			-9	-19	passed
50	10			-7	-22	passed

NB-IoT eFDD71

Temp. °C	Duration min	Voltage	Limit Hz	Freq. error Average (Hz)	Freq. error Max. (Hz)	Verdict
-30	0	normal	6337.5	0	7	passed
-30	5			0	4	passed
-30	10			1	6	passed
-20	0	normal	6337.5	0	5	passed
-20	5			-1	8	passed
-20	10			0	3	passed
-10	0	normal	6337.5	0	4	passed
-10	5			1	4	passed
-10	10			1	5	passed
0	0	normal	6337.5	0	6	passed
0	5			0	4	passed
0	10			-1	7	passed
10	0	normal	6337.5	0	8	passed
10	5			0	4	passed
10	10			0	6	passed
20	0	low	6337.5	1	8	passed
20	5			1	6	passed
20	10			-1	5	passed
20	0	normal	6337.5	1	7	passed
20	5			0	6	passed
20	10			-1	7	passed
20	0	high	6337.5	0	5	passed
20	5			-1	8	passed
20	10			-1	7	passed
30	0	normal	6337.5	0	5	passed
30	5			-1	9	passed
30	10			-1	6	passed
40	0	normal	6337.5	0	7	passed
40	5			1	8	passed
40	10			1	5	passed
50	0	normal	6337.5	-1	6	passed
50	5			1	9	passed
50	10			1	9	passed

NB-IoT eFDD85

Temp. °C	Duration min	Voltage	Limit Hz	Freq. error Average (Hz)	Freq. error Max. (Hz)	Verdict
-30	0	normal	2091.25	-2	11	passed
-30	5			3	15	passed
-30	10			-4	13	passed
-20	0	normal	2091.25	-1	15	passed
-20	5			-2	16	passed
-20	10			3	18	passed
-10	0	normal	2091.25	3	14	passed
-10	5			3	12	passed
-10	10			3	19	passed
0	0	normal	2091.25	-4	17	passed
0	5			-2	18	passed
0	10			1	13	passed
10	0	normal	2091.25	1	16	passed
10	5			-3	14	passed
10	10			0	14	passed
20	0	low	2091.25	-3	12	passed
20	5			-2	14	passed
20	10			-2	17	passed
20	0	normal	2091.25	-3	16	passed
20	5			-2	17	passed
20	10			-2	11	passed
20	0	high	2091.25	-3	18	passed
20	5			0	12	passed
20	10			-2	17	passed
30	0	normal	2091.25	4	19	passed
30	5			-3	12	passed
30	10			-1	13	passed
40	0	normal	2091.25	-2	18	passed
40	5			3	16	passed
40	10			4	10	passed
50	0	normal	2091.25	3	13	passed
50	5			3	14	passed
50	10			-2	17	passed

5.16.4 TEST EQUIPMENT USED

- Radio Lab

5.17 SPURIOUS EMISSIONS AT ANTENNA TERMINALS

Standard **FCC PART 27 Subpart C**

The test was performed according to:
ANSI C63.26: 2015

5.17.1 TEST DESCRIPTION

This test case is intended to demonstrate compliance to the applicable conducted spurious emission test case per § 2.1051 and RSS-GEN 6.13. The limit comes from the applicable rule part and ISED RSS-Standard for the operating band of the cellular device.

The EUT was connected to the test setup according to the following diagram:

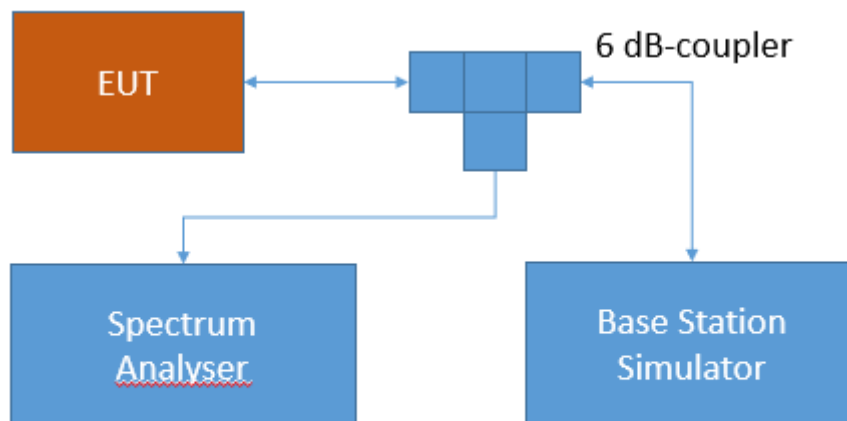

Test Setup FCC Part 22/24/27/90 Cellular;
Spurious Emissions at antenna terminal

The attenuation of the measuring and stimulus path are known for each measured frequency and are considered.

The Spectrum Analyzer settings can be directly found in the measurement diagrams.

5.17.2 TEST REQUIREMENTS / LIMITS

FCC Part 2.1051; Measurement required: Spurious emissions at antenna terminal:

The radio frequency voltage or powers generated within the equipment and appearing on a spurious frequency shall be checked at the equipment output terminals when properly loaded with a suitable artificial antenna. Curves or equivalent data shall show the magnitude of each harmonic and other spurious emission that can be detected when the equipment is operated

under the conditions specified in §2.1049 as appropriate. The magnitude of spurious emissions which are attenuated more than 20 dB below the permissible value need not be specified.

FCC Part 27; Miscellaneous Wireless Communication Services

Subpart C – Technical standards

§27.53 – Emission limits

Band 13

(c) For operations in the 746-758 MHz band and the 776-788 MHz band, the power of any emission outside the licensee's frequency band(s) of operation shall be attenuated below the transmitter power (P) within the licensed band(s) of operation, measured in watts, in accordance with the following:

(1) On any frequency outside the 746-758 MHz band, the power of any emission shall be attenuated outside the band below the transmitter power (P) by at least $43 + 10 \log (P)$ dB;

(2) On any frequency outside the 776-788 MHz band, the power of any emission shall be attenuated outside the band below the transmitter power (P) by at least $43 + 10 \log (P)$ dB;

(3) On all frequencies between 763-775 MHz and 793-805 MHz, by a factor not less than $76 + 10 \log (P)$ dB in a 6.25 kHz band segment, for base and fixed stations;

(4) On all frequencies between 763-775 MHz and 793-805 MHz, by a factor not less than $65 + 10 \log (P)$ dB in a 6.25 kHz band segment, for mobile and portable stations;

(5) Compliance with the provisions of paragraphs (c)(1) and (c)(2) of this section is based on the use of measurement instrumentation employing a resolution bandwidth of 100 kHz or greater. However, in the 100 kHz bands immediately outside and adjacent to the frequency block, a resolution bandwidth of at least 30 kHz may be employed;

(f) For operations in the 746-758 MHz, 775-788 MHz, and 805-806 MHz bands, emissions in the band 1559-1610 MHz shall be limited to -70 dBW/MHz equivalent isotropically radiated power (EIRP) for wideband signals, and -80 dBW EIRP for discrete emissions of less than 700 Hz bandwidth. For the purpose of equipment authorization, a transmitter shall be tested with an antenna that is representative of the type that will be used with the equipment in normal operation.

(6) Compliance with the provisions of paragraphs (c)(3) and (c)(4) of this section is based on the use of measurement instrumentation such that the reading taken with any resolution bandwidth setting should be adjusted to indicate spectral energy in a 6.25 kHz segment.

RSS-130; 4.7.1 General unwanted emissions limits

The unwanted emissions in any 100 kHz bandwidth on any frequency outside the low frequency edge and the high frequency edge of each frequency block range(s), shall be attenuated below the transmitter power, P (dBW), by at least $43 + 10 \log_{10} p$ (watts), dB. However, in the 100 kHz band immediately outside of the equipment's frequency block range, a resolution bandwidth of 30 kHz may be employed.

RSS-130; 4.7.2 Additional unwanted emissions limits

In addition to the limit outlined in section 4.7.1 above, equipment operating in the frequency bands 746-756 MHz and 777-787 MHz shall also comply with the following restrictions:

- a. the power of any unwanted emissions in any 6.25 kHz bandwidth for all frequencies between 763-775 MHz and 793-806 MHz shall be attenuated below the transmitter power, P (dBW), by at least:
 - i. $76 + 10 \log_{10} p$ (watts), dB, for base and fixed equipment and
 - ii. $65 + 10 \log_{10} p$ (watts), dB, for mobile and portable equipment

- b. the e.i.r.p. in the band 1559-1610 MHz shall not exceed -70 dBW/MHz for wideband signal and -80 dBW for discrete emission with bandwidth less than 700 Hz.

Band 12:

(g) For operations in the 600 MHz band and the 698-746 MHz band, the power of any emission outside a licensee's frequency band(s) of operation shall be attenuated below the transmitter power (P) within the licensed band(s) of operation, measured in watts, by at least $43 + 10 \log(P)$ dB. Compliance with this provision is based on the use of measurement instrumentation employing a resolution bandwidth of 100 kilohertz or greater. However, in the 100 kilohertz bands immediately outside and adjacent to a licensee's frequency block, a resolution bandwidth of at least 30 kHz may be employed.

RSS-130; 4.7.1 General unwanted emissions limits

The unwanted emissions in any 100 kHz bandwidth on any frequency outside the low frequency edge and the high frequency edge of each frequency block range(s), shall be attenuated below the transmitter power, P (dBW), by at least $43 + 10 \log_{10} p$ (watts), dB. However, in the 100 kHz band immediately outside of the equipment's frequency block range, a resolution bandwidth of 30 kHz may be employed.

RSS-130; 4.7.2 Additional unwanted emissions limits

In addition to the limit outlined in section 4.7.1 above, equipment operating in the frequency bands 746-756 MHz and 777-787 MHz shall also comply with the following restrictions:

- a. the power of any unwanted emissions in any 6.25 kHz bandwidth for all frequencies between 763-775 MHz and 793-806 MHz shall be attenuated below the transmitter power, P (dBW), by at least:
- i. $76 + 10 \log_{10} p$ (watts), dB, for base and fixed equipment and
 - ii. $65 + 10 \log_{10} p$ (watts), dB, for mobile and portable equipment
- b. the e.i.r.p. in the band 1559-1610 MHz shall not exceed -70 dBW/MHz for wideband signal and -80 dBW for discrete emission with bandwidth less than 700 Hz.

Band 4/10/66:

(h) *AWS emission limits— (1) General protection levels.* Except as otherwise specified below, for operations in the 1695-1710 MHz, 1710-1755 MHz, 1755-1780 MHz, 1915-1920 MHz, 1995-2000 MHz, 2000-2020 MHz, 2110-2155 MHz, 2155-2180 MHz, and 2180-2200 bands, the power of any emission outside a licensee's frequency block shall be attenuated below the transmitter power (P) in watts by at least $43 + 10 \log_{10}(P)$ dB.

RSS-139; 6.6 Transmitter Unwanted Emissions

Equipment shall comply with the limits in (i) and (ii) below.

- i. In the first 1.0 MHz bands immediately outside and adjacent to the equipment's smallest operating frequency block, which can contain the equipment's occupied bandwidth, the emission power per any 1% of the emission bandwidth shall be attenuated below the transmitter output power P (in dBW) by at least $43 + 10 \log_{10} p$ (watts) dB.
- ii. After the first 1.0 MHz outside the equipment's smallest operating frequency block, which can contain the equipment's occupied bandwidth, the emission power in any 1 MHz bandwidth shall be attenuated below the transmitter output power P (in dBW) by at least $43 + 10 \log_{10} p$ (watts) dB.

Band 7:

(m) For BRS and EBS stations, the power of any emissions outside the licensee's frequency bands of operation shall be attenuated below the transmitter power (P) measured in watts in accordance with the standards below. If a licensee has multiple contiguous channels, out-of-band emissions shall be measured from the upper and lower edges of the contiguous channels.

(4) For mobile digital stations, the attenuation factor shall be not less than $40 + 10 \log (P)$ dB on all frequencies between the channel edge and 5 megahertz from the channel edge, $43 + 10 \log (P)$ dB on all frequencies between 5 megahertz and X megahertz from the channel edge, and $55 + 10 \log (P)$ dB on all frequencies more than X megahertz from the channel edge, where X is the greater of 6 megahertz or the actual emission bandwidth as defined in paragraph (m)(6) of this section. In addition, the attenuation factor shall not be less than $43 + 10 \log (P)$ dB on all frequencies between 2490.5 MHz and 2496 MHz and $55 + 10 \log (P)$ dB at or below 2490.5 MHz. Mobile Satellite Service licensees operating on frequencies below 2495 MHz may also submit a documented interference complaint against BRS licensees operating on channel BRS Channel 1 on the same terms and conditions as adjacent channel BRS or EBS licensees.

RSS-199; 4.5 Transmitter unwanted emissions

In the 1 MHz band immediately outside and adjacent to the channel edge, the unwanted emission power shall be measured with a resolution bandwidth of at least 1% of the occupied bandwidth for base station and fixed subscriber equipment, and 2% for mobile subscriber equipment. Beyond the 1 MHz band, a resolution bandwidth of 1 MHz shall be used. A narrower resolution bandwidth can be used, provided that the measured power is integrated over the full required measurement bandwidth of 1 MHz, or 1% or 2% of the occupied bandwidth, as applicable.

Equipment shall comply with the following unwanted emission limits:

b. for mobile subscriber equipment, the power of any unwanted emissions measured as above shall be attenuated (in dB) below the transmitter power, P (dBW), by at least:

$40 + 10 \log_{10} p$ from the channel edges to 5 MHz away

$43 + 10 \log_{10} p$ between 5 MHz and X MHz from the channel edges, and

$55 + 10 \log_{10} p$ at X MHz and beyond from the channel edges

In addition, the attenuation shall not be less than $43 + 10 \log_{10} p$ on all frequencies between 2490.5 MHz and 2496 MHz, and $55 + 10 \log_{10} p$ at or below 2490.5 MHz.

In (b), p is the transmitter power measured in watts and X is 6 MHz or the equipment occupied bandwidth, whichever is greater.

Band 17:

(g) For operations in the 600 MHz band and the 698-746 MHz band, the power of any emission outside a licensee's frequency band(s) of operation shall be attenuated below the transmitter power (P) within the licensed band(s) of operation, measured in watts, by at least $43 + 10 \log(P)$ dB. Compliance with this provision is based on the use of measurement instrumentation employing a resolution bandwidth of 100 kilohertz or greater. However, in the 100 kilohertz bands immediately outside and adjacent to a licensee's frequency block, a resolution bandwidth of at least 30 kHz may be employed.

RSS-130; 4.7.1 General unwanted emissions limits

The unwanted emissions in any 100 kHz bandwidth on any frequency outside the low frequency edge and the high frequency edge of each frequency block range(s), shall be attenuated below the transmitter power, P (dBW), by at least $43 + 10 \log_{10} p$ (watts), dB. However, in the 100 kHz band immediately outside of the equipment's frequency block range, a resolution bandwidth of 30 kHz may be employed.

RSS-130; 4.7.2 Additional unwanted emissions limits

In addition to the limit outlined in section 4.7.1 above, equipment operating in the frequency bands 746-756 MHz and 777-787 MHz shall also comply with the following restrictions:

- a. the power of any unwanted emissions in any 6.25 kHz bandwidth for all frequencies between 763-775 MHz and 793-806 MHz shall be attenuated below the transmitter power, P (dBW), by at least:
 - i. $76 + 10 \log_{10} p$ (watts), dB, for base and fixed equipment and
 - ii. $65 + 10 \log_{10} p$ (watts), dB, for mobile and portable equipment
- b. the e.i.r.p. in the band 1559-1610 MHz shall not exceed -70 dBW/MHz for wideband signal and -80 dBW for discrete emission with bandwidth less than 700 Hz.

5.17.3 TEST PROTOCOL

Temperature 20 – 25 °C
Humidity 30 - 40 %

Radio Technology	Channel	Detector	Trace	Resolution Bandwidth /kHz	Frequency /MHz	Peak Value /dBm	Limit /dBm	Margin to Limit /dB
CAT-M1 eFDD8	low	rms	maxhold	20	897.49	-31.24	-13	18.24
CAT-M1 eFDD8	mid	rms	maxhold	-	-	-	-13	>20
CAT-M1 eFDD8	high	rms	maxhold	20	900.50	-36.34	-13	23.34

Radio Technology	Channel	Detector	Trace	Resolution Bandwidth /kHz	Frequency /MHz	Peak Value /dBm	Limit /dBm	Margin to Limit /dB
CAT-M1 eFDD66	low	rms	maxhold	20	1709.98	-31.51	-13	18.51
CAT-M1 eFDD66	mid	rms	maxhold	-	-	-	-13	>20
CAT-M1 eFDD66	high	rms	maxhold	20	1780.00	-37.88	-13	24.88

Radio Technology	Channel	Detector	Trace	Resolution Bandwidth /kHz	Frequency /MHz	Peak Value /dBm	Limit /dBm	Margin to Limit /dB
CAT-M1 eFDD71	low	rms	maxhold	30	663	-31.06	-13	18.06
CAT-M1 eFDD71	mid	rms	maxhold	-	-	-	-13	>20
CAT-M1 eFDD71	high	rms	maxhold	30	698.04	-36.45	-13	23.45

Radio Technology	Channel	Detector	Trace	Resolution Bandwidth /kHz	Frequency /MHz	Peak Value /dBm	Limit /dBm	Margin to Limit /dB
NB-IoT eFDD4	low	rms	maxhold	2	1709.96	-15.28	-13	2.28
NB-IoT eFDD4	mid	rms	maxhold	-	-	-	-13	>20
NB-IoT eFDD4	high	rms	maxhold	2	1755.03	-19.57	-13	6.57

Radio Technology	Channel	Detector	Trace	Resolution Bandwidth /kHz	Frequency /MHz	Peak Value /dBm	Limit /dBm	Margin to Limit /dB
NB-IoT eFDD8	low	rms	maxhold	2	897.49	-21.28	-13	8.28
NB-IoT eFDD8	mid	rms	maxhold	-	-	-	-13	>20
NB-IoT eFDD8	high	rms	maxhold	2	900.50	-14.06	-13	1.06

Radio Technology	Channel	Detector	Trace	Resolution Bandwidth /kHz	Frequency /MHz	Peak Value /dBm	Limit /dBm	Margin to Limit /dB
NB-IoT eFDD12	low	rms	maxhold	-	-	-	-13	>20
NB-IoT eFDD12	mid	rms	maxhold	-	-	-	-13	>20
NB-IoT eFDD12	high	rms	maxhold	30	716.00	-21.80	-13	8.80

Radio Technology	Channel	Detector	Trace	Resolution Bandwidth /kHz	Frequency /MHz	Peak Value /dBm	Limit /dBm	Margin to Limit /dB
NB-IoT eFDD13	low	rms	maxhold	-	-	-	-13	>20
NB-IoT eFDD13	mid	rms	maxhold	-	-	-	-13	>20
NB-IoT eFDD13	high	rms	maxhold	-	-	-	-13	>20

Radio Technology	Channel	Detector	Trace	Resolution Bandwidth /kHz	Frequency /MHz	Peak Value /dBm	Limit /dBm	Margin to Limit /dB
NB-IoT eFDD66	low	rms	maxhold	2	1709.99	-22.32	-13	9.32
NB-IoT eFDD66	mid	rms	maxhold	-	-	-	-13	>20
NB-IoT eFDD66	high	rms	maxhold	2	1780.00	-19.64	-13	6.64
NB-IoT eFDD66	high	rms	maxhold	100	1781.02	-35.94	-23	12.94

Radio Technology	Channel	Detector	Trace	Resolution Bandwidth /kHz	Frequency /MHz	Peak Value /dBm	Limit /dBm	Margin to Limit /dB
NB-IoT eFDD71	low	rms	maxhold	30	662.99	-26.75	-13	13.75
NB-IoT eFDD71	mid	rms	maxhold	-	-	-	-13	>20
NB-IoT eFDD71	high	rms	maxhold	30	698.02	-28.6	-13	15.60

Radio Technology	Channel	Detector	Trace	Resolution Bandwidth /kHz	Frequency /MHz	Peak Value /dBm	Limit /dBm	Margin to Limit /dB
NB-IoT eFDD85	low	rms	maxhold	30	698.00	-22.58	-13	9.58
NB-IoT eFDD85	mid	rms	maxhold	-	-	-	-13	>20
NB-IoT eFDD85	high	rms	maxhold	30	716.01	-23.84	-13	10.84

Remark: Please see next sub-clause for the measurement plot.

5.17.4 MEASUREMENT PLOT (EXAMPLE PLOT, SHOWING WORST CASE, IF APPLICABLE)

CAT-M1 eFDD8 QPSK, Channel = low

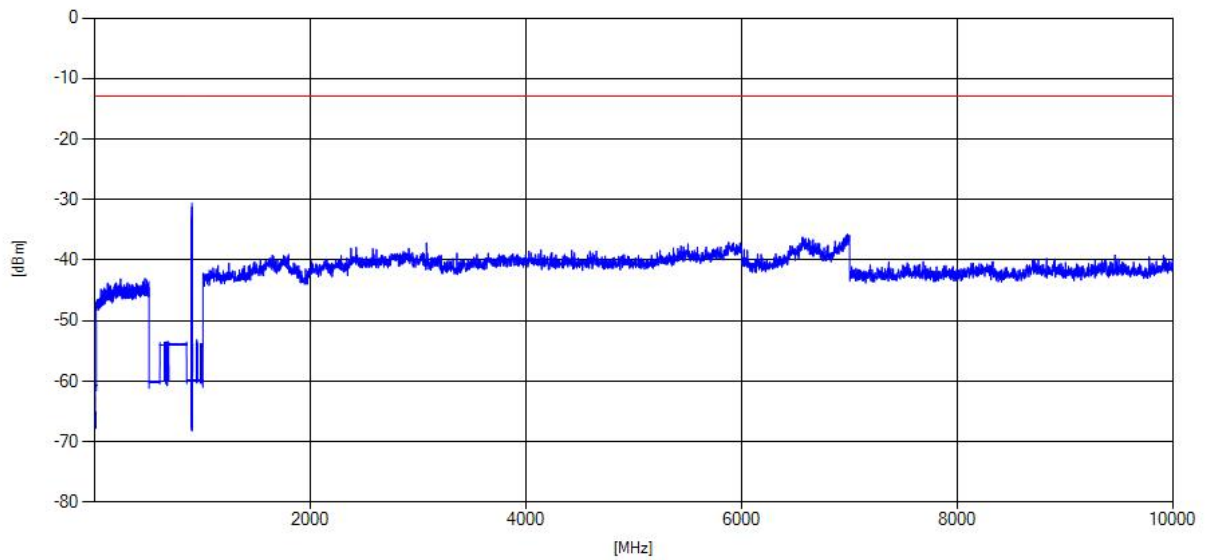

CAT-M1 eFDD66 QPSK, Channel = low

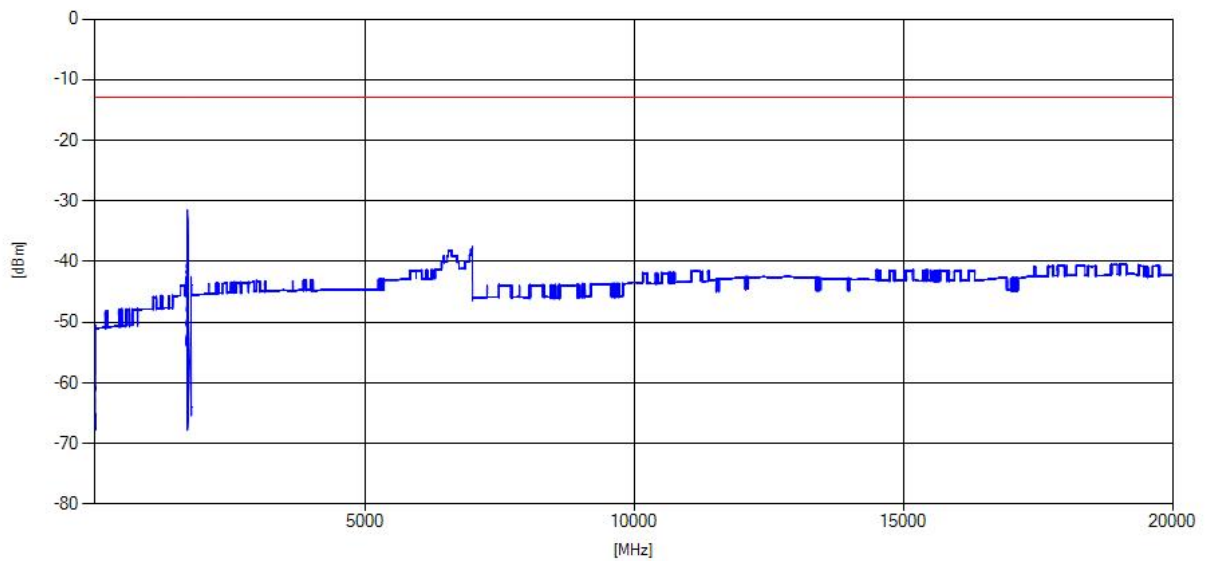

CAT-M1 eFDD71 QPSK, Channel = low

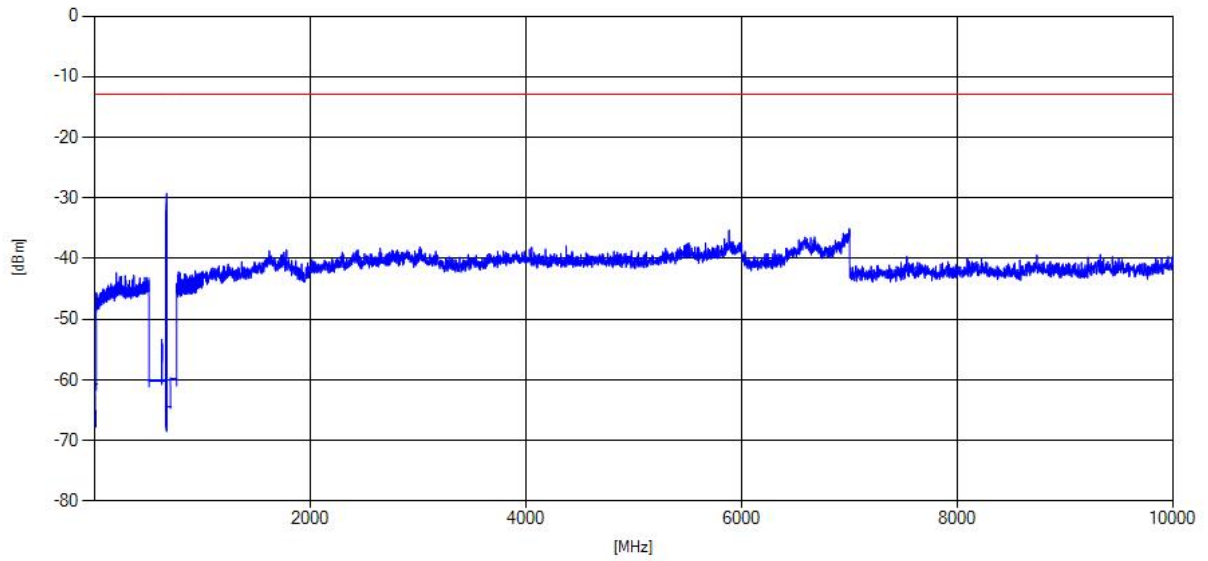

NB-IoT eFDD4 QPSK, Channel = low

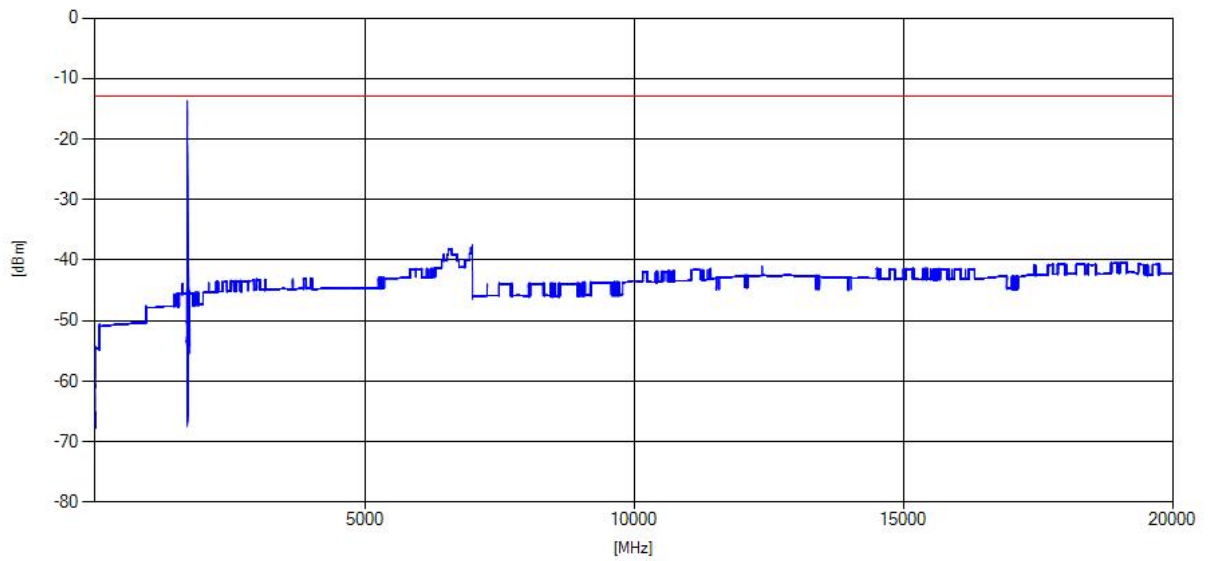

NB-IoT eFDD8 QPSK, Channel = high

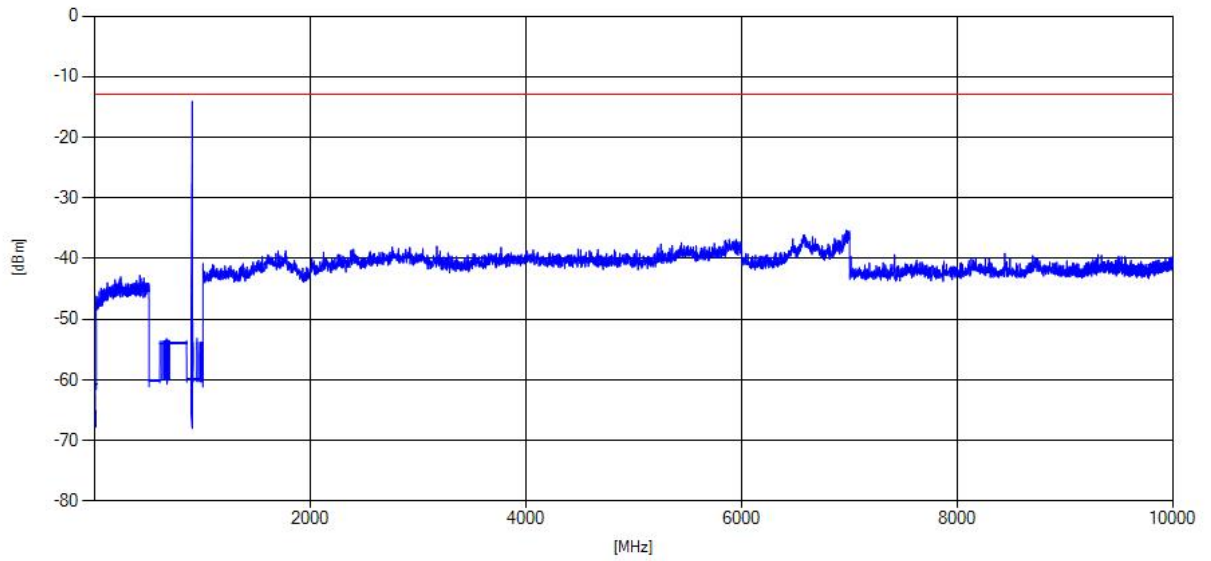

NB-IoT eFDD12 QPSK, Channel = high

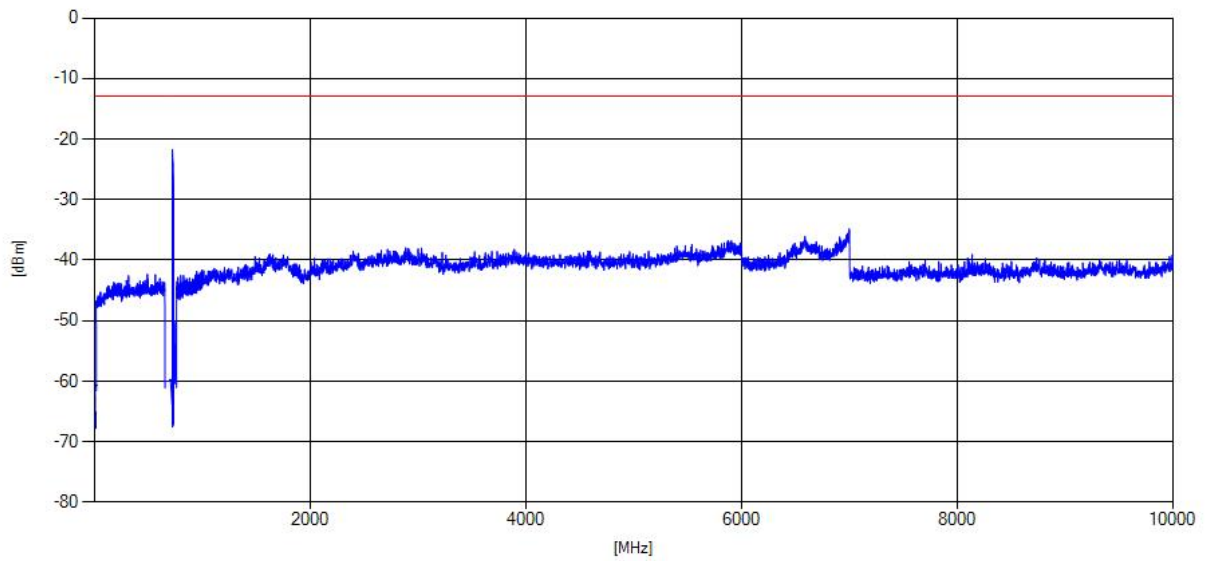

NB-IoT eFDD13 QPSK, Channel = mid

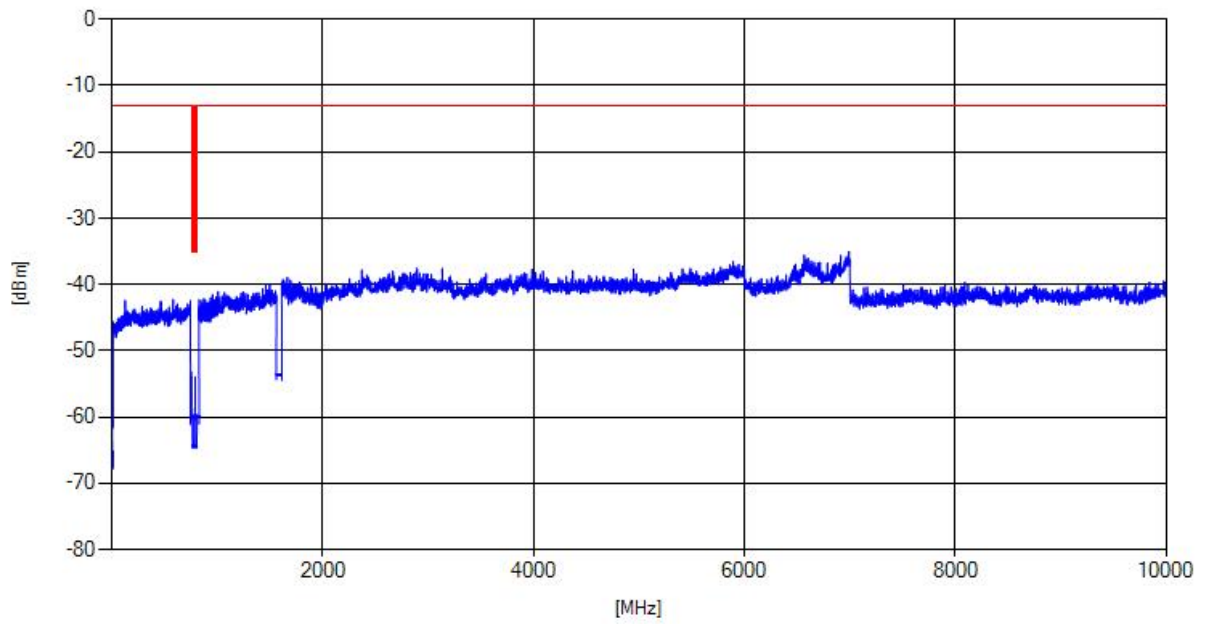

NB-IoT eFDD66 QPSK, Channel = high

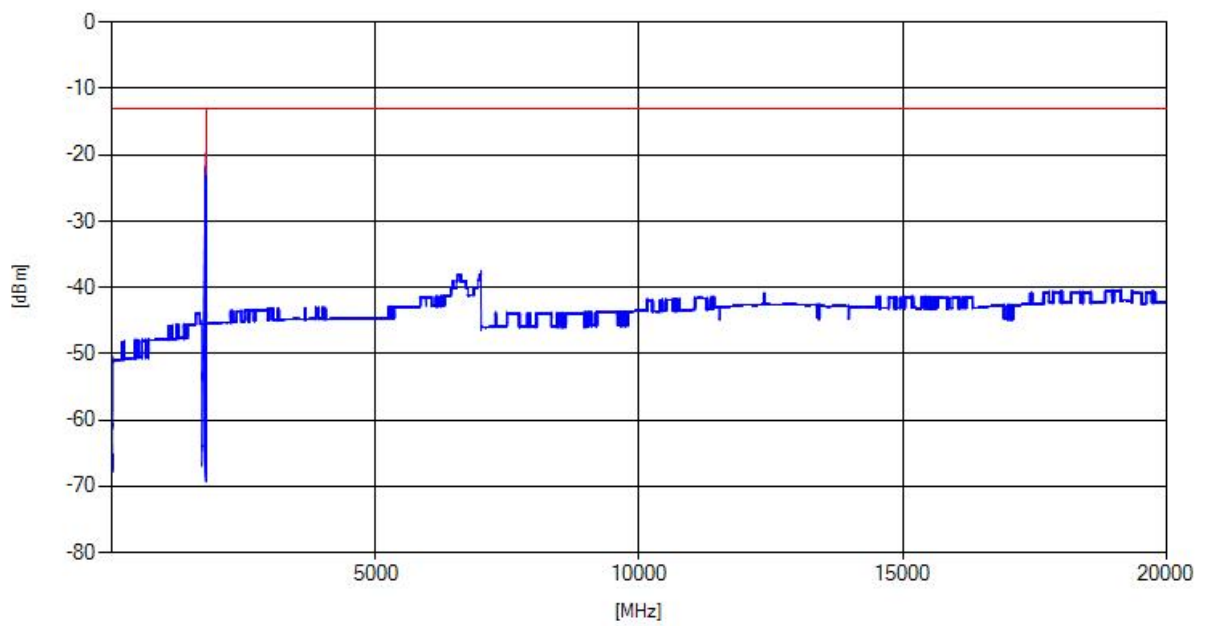

NB-IoT eFDD71 QPSK, Channel = low

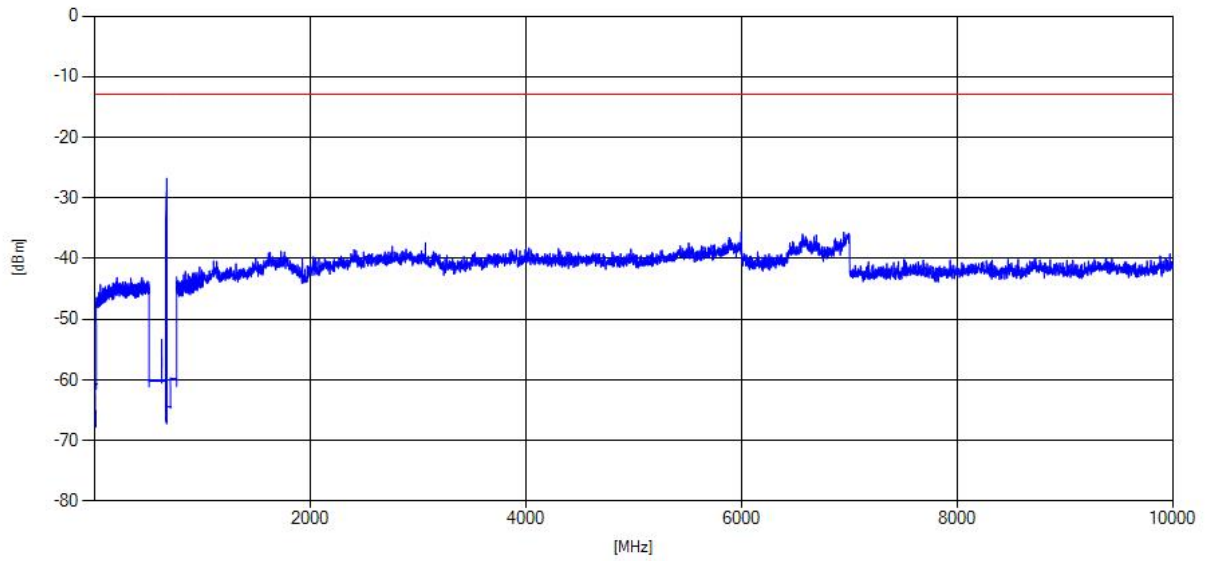

NB-IoT eFDD85 QPSK, Channel = low

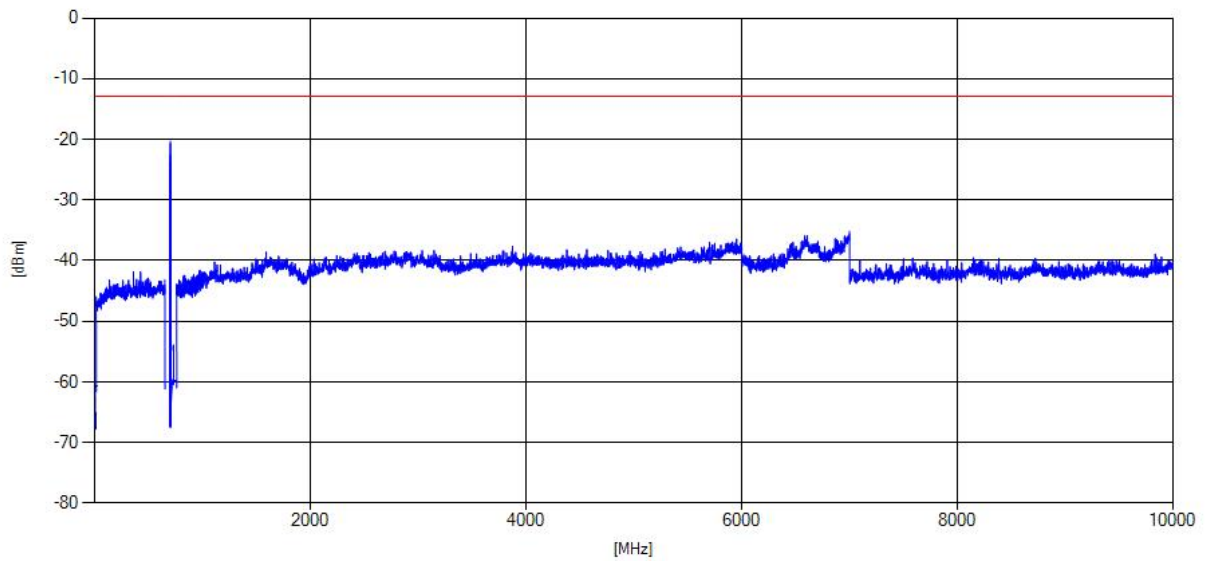

5.17.5 TEST EQUIPMENT USED

- Radio Lab

5.18 FIELD STRENGTH OF SPURIOUS RADIATION

Standard **FCC PART 27 Subpart C**

The test was performed according to:
ANSI C63.26: 2015

5.18.1 TEST DESCRIPTION

This test case is intended to demonstrate compliance to the applicable radiated spurious emission measurements per § 2.1053 and RSS-GEN 6.13. The limit and requirements come from the applicable rule part and ISED RSS-Standard for the operating band of the cellular device.

The EUT was connected to the test setup according to the following diagram:

Frequency Range: 30 MHz – 1 GHz:

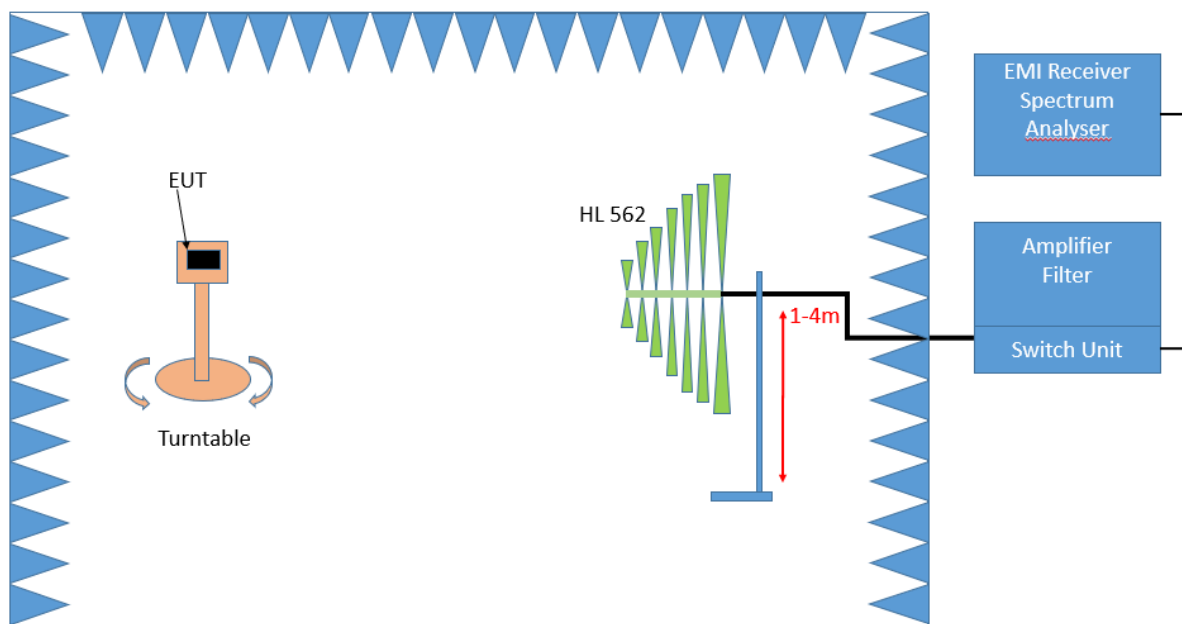

Test Setup; Spurious Emission Radiated (SAC), 30 MHz- 1GHz

Frequency Range: 1 GHz – 26.5 GHz

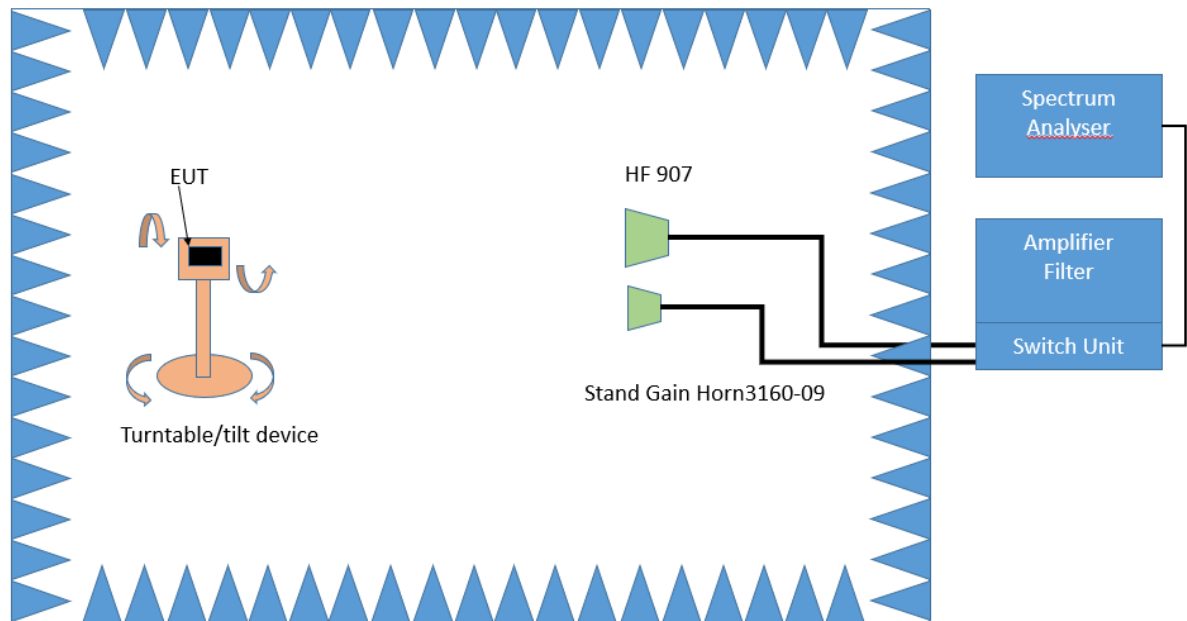

Test Setup; Spurious Emission Radiated (FAC), 1 GHz-26.5 GHz

The test set-up was made in accordance to the general provisions of ANSI C63.26 in a typical installation configuration. The Equipment Under Test (EUT) was set up on a non-conductive table 1.0 x 2.0 m² in the semi-anechoic chamber. The influence of the EUT support table that is used between 30–1000 MHz was evaluated.

The measurement procedure is implemented into the EMI test software EMC32 from R&S. Exploratory tests are performed at 3 orthogonal axes to determine the worst-case orientation of a body-worn or handheld EUT. The final test on all kind of EUTs is also performed at 3 axes. A pre-check is performed while the EUT is powered from a DC power source.

1. Measurement above 30 MHz and up to 1 GHz

Step 1: Preliminary scan

This is a preliminary test to identify the highest amplitudes relative to the limit.

Settings for step 1:

- Antenna distance: 3 m
- Detector: Peak
- RBW: 100 kHz
- VBW: 300 kHz
- Sweep time: coupled
- Turntable angle range: -180° to 90°
- Turntable step size: 90°
- Height variation range: 1 – 4 m
- Height variation step size: 1.5 m
- Polarisation: Horizontal + Vertical

Intention of this step is, to determine the radiated EMI-profile of the EUT. Afterwards the relevant emissions for the final measurement are identified.

Step 2: Adjustment measurement

In this step the accuracy of the turntable azimuth and antenna height will be improved. This is necessary to find out the maximum value of every frequency.

For each frequency, which was determined the turntable azimuth and antenna height will be adjusted. The turntable azimuth will slowly vary by $\pm 45^{\circ}$ around this value. During this action, the value of emission is continuously measured. The turntable azimuth at the highest emission will be recorded and adjusted. In this position, the antenna height will also slowly vary by \pm

100 cm around the antenna height determined. During this action, the value of emission is also continuously measured. The antenna height of the highest emission will also be recorded and adjusted.

- Detector: Peak
- Measured frequencies: in step 1 determined frequencies
- RBW: 100 kHz
- VBW: 300 kHz
- Sweep time: coupled
- Turntable angle range: $\pm 45^\circ$ around the determined value
- Height variation range: ± 100 cm around the determined value
- Antenna Polarisation: max. value determined in step 1

Step 3: Final measurement with RMS detector

With the settings determined in step 3, the final measurement will be performed:

EMI receiver settings for step 4:

- Detector: RMQ
- Measured frequencies: in step 1 determined frequencies
- RBW: 100 kHz
- VBW: 300 kHz
- Sweep time: 1 s

After the measurement a plot will be generated which contains a diagram with the results of the preliminary scan and a chart with the frequencies and values of the results of the final measurement.

3. Measurement above 1 GHz

The following modifications apply to the measurement procedure for the frequency range above 1 GHz:

Step 1:

The Equipment Under Test (EUT) was set up on a non-conductive support (tilt device) at 1.5 m height in the fully-anechoic chamber.

All steps were performed with one height (1.5 m) of the receiving antenna only.

The EUT is turned during the preliminary measurement across the elevation axis, with a step size of 90° .

The turn table step size (azimuth angle) for the preliminary measurement is 45° .

- Antenna distance: 3 m
- Detector: Peak
- RBW: 1 MHz
- VBW: 3 MHz
- Sweep time: coupled
- Turntable angle range: -180° to 90°
- Turntable step size: 90°
- Polarisation: Horizontal + Vertical

Step 2:

Due to the fact, that in this frequency range the test is performed in a fully anechoic room, the height scan of the receiving antenna instep 2 is omitted. Instead of this, a maximum search with a step size $\pm 45^\circ$ for the elevation axis is performed.

The turn table azimuth will slowly vary by $\pm 22.5^\circ$.

The elevation angle will slowly vary by $\pm 45^\circ$

EMI receiver settings (for all steps):

- Detector: Peak,
- RBW: 1 MHz
- VBW: 3 MHz
- Sweep time: coupled

Step 3:

Spectrum analyser settings for step 3:

- Detector: RMS
- Measured frequencies: in step 1 determined frequencies
- RBW: 1 MHz
- VBW: 3 MHz
- Sweep Time: 1 s

5.18.2 TEST REQUIREMENTS / LIMITS

FCC Part 2.1053; Measurement required: Field strength of spurious radiation:

Measurements shall be made to detect spurious emissions that may be radiated directly from the cabinet, control circuits, power leads, or intermediate circuit elements under normal conditions of installation and operation. Curves or equivalent data shall be supplied showing the magnitude of each harmonic and other spurious emission. For this test, single sideband, independent sideband, and controlled carrier transmitters shall be modulated under the conditions specified in paragraph (c) of §2.1049, as appropriate.

FCC Part 27; Miscellaneous Wireless Communication Services**Subpart C – Technical standards****§27.53 – Emission limits****Band 13**

(c) For operations in the 746-758 MHz band and the 776-788 MHz band, the power of any emission outside the licensee's frequency band(s) of operation shall be attenuated below the transmitter power (P) within the licensed band(s) of operation, measured in watts, in accordance with the following:

- (1) On any frequency outside the 746-758 MHz band, the power of any emission shall be attenuated outside the band below the transmitter power (P) by at least $43 + 10 \log (P)$ dB;
- (2) On any frequency outside the 776-788 MHz band, the power of any emission shall be attenuated outside the band below the transmitter power (P) by at least $43 + 10 \log (P)$ dB;
- (3) On all frequencies between 763-775 MHz and 793-805 MHz, by a factor not less than $76 + 10 \log (P)$ dB in a 6.25 kHz band segment, for base and fixed stations;
- (4) On all frequencies between 763-775 MHz and 793-805 MHz, by a factor not less than $65 + 10 \log (P)$ dB in a 6.25 kHz band segment, for mobile and portable stations;
- (5) Compliance with the provisions of paragraphs (c)(1) and (c)(2) of this section is based on the use of measurement instrumentation employing a resolution bandwidth of 100 kHz or greater. However, in the 100 kHz bands immediately outside and adjacent to the frequency block, a resolution bandwidth of at least 30 kHz may be employed;
- (f) For operations in the 746-758 MHz, 775-788 MHz, and 805-806 MHz bands, emissions in the band 1559-1610 MHz shall be limited to -70 dBW/MHz equivalent isotropically radiated power (EIRP) for wideband signals, and -80 dBW EIRP for discrete emissions of less than 700 Hz bandwidth. For the purpose of equipment authorization, a transmitter shall be tested with an antenna that is representative of the type that will be used with the equipment in normal operation.

(6) Compliance with the provisions of paragraphs (c)(3) and (c)(4) of this section is based on the use of measurement instrumentation such that the reading taken with any resolution bandwidth setting should be adjusted to indicate spectral energy in a 6.25 kHz segment.

RSS-130; 4.7.1 General unwanted emissions limits

The unwanted emissions in any 100 kHz bandwidth on any frequency outside the low frequency edge and the high frequency edge of each frequency block range(s), shall be attenuated below the transmitter power, P (dBW), by at least $43 + 10 \log_{10} p$ (watts), dB. However, in the 100 kHz band immediately outside of the equipment's frequency block range, a resolution bandwidth of 30 kHz may be employed.

RSS-130; 4.7.2 Additional unwanted emissions limits

In addition to the limit outlined in section 4.7.1 above, equipment operating in the frequency bands 746-756 MHz and 777-787 MHz shall also comply with the following restrictions:

- a. the power of any unwanted emissions in any 6.25 kHz bandwidth for all frequencies between 763-775 MHz and 793-806 MHz shall be attenuated below the transmitter power, P (dBW), by at least:
 - i. $76 + 10 \log_{10} p$ (watts), dB, for base and fixed equipment and
 - ii. $65 + 10 \log_{10} p$ (watts), dB, for mobile and portable equipment
- b. the e.i.r.p. in the band 1559-1610 MHz shall not exceed -70 dBW/MHz for wideband signal and -80 dBW for discrete emission with bandwidth less than 700 Hz.

Band 12:

(g) For operations in the 600 MHz band and the 698-746 MHz band, the power of any emission outside a licensee's frequency band(s) of operation shall be attenuated below the transmitter power (P) within the licensed band(s) of operation, measured in watts, by at least $43 + 10 \log(P)$ dB. Compliance with this provision is based on the use of measurement instrumentation employing a resolution bandwidth of 100 kilohertz or greater. However, in the 100 kilohertz bands immediately outside and adjacent to a licensee's frequency block, a resolution bandwidth of at least 30 kHz may be employed.

RSS-130; 4.7.1 General unwanted emissions limits

The unwanted emissions in any 100 kHz bandwidth on any frequency outside the low frequency edge and the high frequency edge of each frequency block range(s), shall be attenuated below the transmitter power, P (dBW), by at least $43 + 10 \log_{10} p$ (watts), dB. However, in the 100 kHz band immediately outside of the equipment's frequency block range, a resolution bandwidth of 30 kHz may be employed.

RSS-130; 4.7.2 Additional unwanted emissions limits

In addition to the limit outlined in section 4.7.1 above, equipment operating in the frequency bands 746-756 MHz and 777-787 MHz shall also comply with the following restrictions:

- a. the power of any unwanted emissions in any 6.25 kHz bandwidth for all frequencies between 763-775 MHz and 793-806 MHz shall be attenuated below the transmitter power, P (dBW), by at least:
 - i. $76 + 10 \log_{10} p$ (watts), dB, for base and fixed equipment and
 - ii. $65 + 10 \log_{10} p$ (watts), dB, for mobile and portable equipment

- b. the e.i.r.p. in the band 1559-1610 MHz shall not exceed -70 dBW/MHz for wideband signal and -80 dBW for discrete emission with bandwidth less than 700 Hz.

Band 4/10/66:

(h) *AWS emission limits—(1) General protection levels.* Except as otherwise specified below, for operations in the 1695-1710 MHz, 1710-1755 MHz, 1755-1780 MHz, 1915-1920 MHz, 1995-2000 MHz, 2000-2020 MHz, 2110-2155 MHz, 2155-2180 MHz, and 2180-2200 bands, the power of any emission outside a licensee's frequency block shall be attenuated below the transmitter power (P) in watts by at least $43 + 10 \log_{10} (P)$ dB.

RSS-139; 6.6 Transmitter Unwanted Emissions

Equipment shall comply with the limits in (i) and (ii) below.

- i. In the first 1.0 MHz bands immediately outside and adjacent to the equipment's smallest operating frequency block, which can contain the equipment's occupied bandwidth, the emission power per any 1% of the emission bandwidth shall be attenuated below the transmitter output power P (in dBW) by at least $43 + 10 \log_{10} p$ (watts) dB.
- ii. After the first 1.0 MHz outside the equipment's smallest operating frequency block, which can contain the equipment's occupied bandwidth, the emission power in any 1 MHz bandwidth shall be attenuated below the transmitter output power P (in dBW) by at least $43 + 10 \log_{10} p$ (watts) dB.

Band 7:

(m) For BRS and EBS stations, the power of any emissions outside the licensee's frequency bands of operation shall be attenuated below the transmitter power (P) measured in watts in accordance with the standards below. If a licensee has multiple contiguous channels, out-of-band emissions shall be measured from the upper and lower edges of the contiguous channels.

(4) For mobile digital stations, the attenuation factor shall be not less than $40 + 10 \log (P)$ dB on all frequencies between the channel edge and 5 megahertz from the channel edge, $43 + 10 \log (P)$ dB on all frequencies between 5 megahertz and X megahertz from the channel edge, and $55 + 10 \log (P)$ dB on all frequencies more than X megahertz from the channel edge, where X is the greater of 6 megahertz or the actual emission bandwidth as defined in paragraph (m)(6) of this section. In addition, the attenuation factor shall not be less than $43 + 10 \log (P)$ dB on all frequencies between 2490.5 MHz and 2496 MHz and $55 + 10 \log (P)$ dB at or below 2490.5 MHz. Mobile Satellite Service licensees operating on frequencies below 2495 MHz may also submit a documented interference complaint against BRS licensees operating on channel BRS Channel 1 on the same terms and conditions as adjacent channel BRS or EBS licensees.

RSS-199; 4.5 Transmitter unwanted emissions

In the 1 MHz band immediately outside and adjacent to the channel edge, the unwanted emission power shall be measured with a resolution bandwidth of at least 1% of the occupied bandwidth for base station and fixed subscriber equipment, and 2% for mobile subscriber equipment. Beyond the 1 MHz band, a resolution bandwidth of 1 MHz shall be used. A narrower resolution bandwidth can be used, provided that the measured power is integrated over the full required measurement bandwidth of 1 MHz, or 1% or 2% of the occupied bandwidth, as applicable.

Equipment shall comply with the following unwanted emission limits:

b. for mobile subscriber equipment, the power of any unwanted emissions measured as above shall be attenuated (in dB) below the transmitter power, P (dBW), by at least:

$40 + 10 \log_{10} p$ from the channel edges to 5 MHz away

$43 + 10 \log_{10} p$ between 5 MHz and X MHz from the channel edges, and

$55 + 10 \log_{10} p$ at X MHz and beyond from the channel edges

In addition, the attenuation shall not be less than $43 + 10 \log_{10} p$ on all frequencies between 2490.5 MHz and 2496 MHz, and $55 + 10 \log_{10} p$ at or below 2490.5 MHz.

In (b), p is the transmitter power measured in watts and X is 6 MHz or the equipment occupied bandwidth, whichever is greater.

Band 17:

(g) For operations in the 600 MHz band and the 698-746 MHz band, the power of any emission outside a licensee's frequency band(s) of operation shall be attenuated below the transmitter power (P) within the licensed band(s) of operation, measured in watts, by at least $43 + 10 \log (P)$ dB. Compliance with this provision is based on the use of measurement instrumentation employing a resolution bandwidth of 100 kilohertz or greater. However, in the 100 kilohertz bands immediately outside and adjacent to a licensee's frequency block, a resolution bandwidth of at least 30 kHz may be employed.

RSS-130; 4.7.1 General unwanted emissions limits

The unwanted emissions in any 100 kHz bandwidth on any frequency outside the low frequency edge and the high frequency edge of each frequency block range(s), shall be below the transmitter power, P (dBW), by at least $43 + 10 \log_{10} p$ (watts), dB. However, in the 100

kHz band immediately outside of the equipment's frequency block range, a resolution bandwidth of 30 kHz may be employed.

RSS-130; 4.7.2 Additional unwanted emissions limits

In attenuated addition to the limit outlined in section 4.7.1 above, equipment operating in the frequency bands 746-756 MHz and 777-787 MHz shall also comply with the following restrictions:

- a. the power of any unwanted emissions in any 6.25 kHz bandwidth for all frequencies between 763-775 MHz and 793-806 MHz shall be attenuated below the transmitter power, P (dBW), by at least:
 - i. $76 + 10 \log_{10} p$ (watts), dB, for base and fixed equipment and
 - ii. $65 + 10 \log_{10} p$ (watts), dB, for mobile and portable equipment
- b. the e.i.r.p. in the band 1559-1610 MHz shall not exceed -70 dBW/MHz for wideband signal and -80 dBW for discrete emission with bandwidth less than 700 Hz.

5.18.3 TEST PROTOCOL

Temperature 20 – 25 °C
Humidity 30 - 40 %

Radio Technology	Channel	Detector	Trace	Resolution Bandwidth /kHz	Frequency /MHz	Peak Value /dBm	Limit /dBm	Margin to Limit /dB
CAT-M1 eFDD4	mid	rms	maxhold	-	-	-	-13	>20

Radio Technology	Channel	Detector	Trace	Resolution Bandwidth /kHz	Frequency /MHz	Peak Value /dBm	Limit /dBm	Margin to Limit /dB
CAT-M1 eFDD8	low	rms	maxhold	100	897.40	-36.42	-13	23.42
CAT-M1 eFDD8	mid	rms	maxhold	-	-	-	-13	>20
CAT-M1 eFDD8	high	rms	maxhold	100	900.60	-24.55	-13	11.55

Radio Technology	Channel	Detector	Trace	Resolution Bandwidth /kHz	Frequency /MHz	Peak Value /dBm	Limit /dBm	Margin to Limit /dB
CAT-M1 eFDD12	mid	rms	maxhold	-	-	-	-13	>20

Radio Technology	Channel	Detector	Trace	Resolution Bandwidth /kHz	Frequency /MHz	Peak Value /dBm	Limit /dBm	Margin to Limit /dB
CAT-M1 eFDD13	mid	rms	maxhold	-	-	-	-13	>20

Radio Technology	Channel	Detector	Trace	Resolution Bandwidth /kHz	Frequency /MHz	Peak Value /dBm	Limit /dBm	Margin to Limit /dB
CAT-M1 eFDD66	low	rms	maxhold	5	1709.97	-37.4	-17.5	19.9
CAT-M1 eFDD66	mid	rms	maxhold	-	-	-	-13	>20
CAT-M1 eFDD66	high	rms	maxhold	5	1780.00	-28.15	-13	15.15

Radio Technology	Channel	Detector	Trace	Resolution Bandwidth /kHz	Frequency /MHz	Peak Value /dBm	Limit /dBm	Margin to Limit /dB
CAT-M1 eFDD71	low	rms	maxhold	30	663	-21.6	-13	8.6
CAT-M1 eFDD71	mid	rms	maxhold	-	-	-	-13	>20
CAT-M1 eFDD71	high	rms	maxhold	30	698.10	-21.47	-13	8.47

Remark: Please see next sub-clause for the measurement plot.

5.18.4 MEASUREMENT PLOT (EXAMPLE PLOT, SHOWING WORST CASE, IF APPLICABLE)

CAT-M1 eFDD4 QPSK, Channel = mid

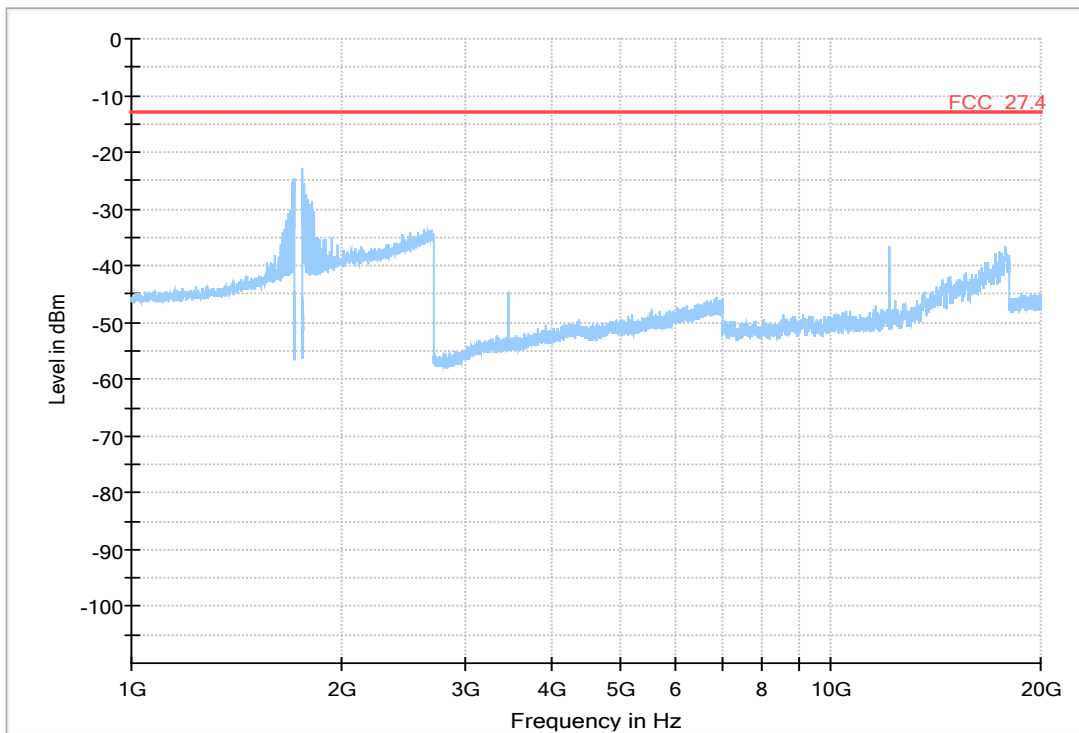

CAT-M1 eFDD8 QPSK, Channel = low
30 MHz - 1 GHz

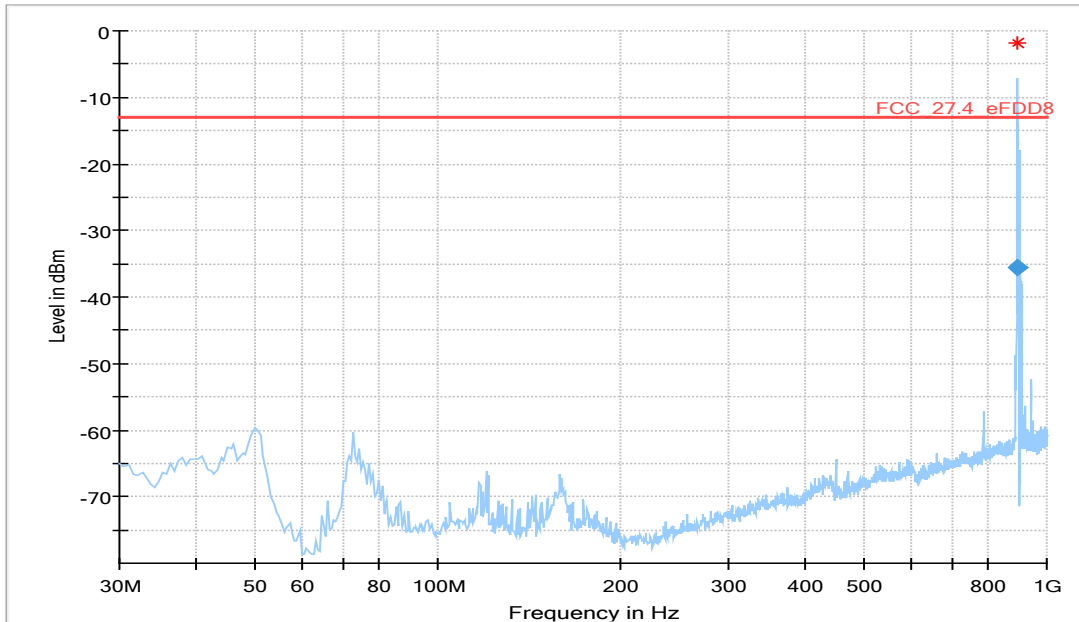

Frequency (MHz)	RMS (dBm)	Limit (dBm)	Margin (dB)	Meas. Time (ms)	Bandwidth (kHz)	Height (cm)	Pol	Azimuth (deg)	Corr. (dB)
897.400000	-35.42	-13.00	22.42	1000.0	100.000	109.0	H	-105.0	-73.1

1 GHz - 10 GHz

