

Emissions Test Report

EUT Name: Wi-Fi Router
Model No.: B010001 (USA), B010002 (IC)
CFR 47 Part 15.407 2016 and RSS 247: 2017

Prepared for:

Clifford Clarke
eero inc.
500 Howard Street, Suite 900
San Francisco, CA 94105
Tel: (415) 738-7972
Fax:

Prepared by:

TUV Rheinland of North America, Inc.
1279 Quarry Lane
Pleasanton, CA 94566
Tel: (925) 249-9123
Fax: (925) 249-9124
<http://www.tuv.com/>

Report/Issue Date: May 11, 2017
Job # 0000146430
Report Number: 31761399.001

Revisions

Revision No.	Date MM/DD/YYYY	Reason for Change	Author
0	05/10/2017	Original Document	N/A

Note: Latest revision report will replace all previous reports.

Statement of Compliance

Manufacturer: eero inc.
500 Howard Street, Suite 900
San Francisco, CA 94105
(415) 738-7972

Requester / Applicant: Clifford Clarke

Name of Equipment: Wi-Fi Router
Model No. B010001 (USA), B010002 (IC)
Type of Equipment: Intentional Radiator
Application of Regulations: CFR 47 Part 15.407 2016 and RSS 247: 2017
Test Dates: 05 Apr 2017 to 04 May 2017

Guidance Documents:

Emissions: ANSI C63.10-2013, KDB 789033 D02 General UNII Test Procedures New Rules v01, KDB 662911 D01 Multiple Transmitter Output v02r01

Test Methods:

Emissions: ANSI C63.10-2013, KDB 789033 D02 General UNII Test Procedures New Rules v01, KDB 662911 D01 Multiple Transmitter Output v02r01

The electromagnetic compatibility test and documented data described in this report has been performed and recorded by TUV Rheinland, in accordance with the standards and procedures listed herein. As the responsible authorized agent of the EMC laboratory, I hereby declare that the equipment described above has been shown to be compliant with the EMC requirements of the stated regulations and standards based on these results. If any special accessories and/or modifications were required for compliance, they are listed in the Executive Summary of this report.

This report must not be used to claim product endorsement by A2LA or any agency of the U.S. Government. This report contains data that are not covered by A2LA accreditation. This report shall not be reproduced except in full, without the written authorization of TUV Rheinland of North America.

Kerwinn Corpuz

David Spencer

Test Engineer

Date April 10, 2017

A2LA Signatory

Date April 10, 2017



Testing Cert #3331.02

US1131

2932M

Table of Contents

1	Executive Summary	8
1.1	Scope	8
1.2	Purpose	8
1.3	Summary of Test Results	9
1.4	Special Accessories	9
1.5	Equipment Modifications	9
2	Laboratory Information	10
2.1	Accreditations & Endorsements	10
2.1.1	US Federal Communications Commission	10
2.1.2	NIST/ A2LA	10
2.1.3	Canada – Industry Canada	10
2.1.4	Japan – VCCI	10
2.1.5	Acceptance by Mutual Recognition Arrangement	11
2.2	Test Facilities	11
2.2.1	Emission Test Facility	11
2.2.2	Immunity Test Facility	11
2.3	Measurement Uncertainty	11
2.3.1	Sample Calculation – radiated & conducted emissions	12
2.3.2	Measurement Uncertainty	12
2.3.3	Measurement Uncertainty Immunity	13
2.4	Calibration Traceability	13
3	Product Information	14
3.1	Product Description	14
3.2	Equipment Configuration	14
3.3	Operating Mode	14
3.4	Unique Antenna Connector	15
3.4.1	Results	15
4	Emissions	16
4.1	Output Power Requirements	16
4.1.1	Test Method	16
4.1.2	Results	17
4.2	Occupied Bandwidth	35
4.2.1	Test Method	35
4.2.2	Results	35
4.3	Peak Power Spectral Density	41
4.3.1	Test Method	41
4.3.2	Results	41
4.4	Undesirable Emission Limits	60
4.4.1	Test Method	60
4.4.2	Results	60

Table of Contents

4.5	Transmitter Spurious Emissions	79
4.5.1	Test Methodology	79
4.5.2	Transmitter Spurious Emission Limit	80
4.5.3	Results	80
4.6	AC Conducted Emissions	106
4.6.1	Test Methodology	106
4.6.2	Test Results	106
4.7	Frequency Stability	111
4.7.1	Test Methodology	111
4.7.2	Manufacturer Declaration	111
4.7.3	Limit	112
4.7.4	Test results:	112
4.8	Voltage Variation	114
4.8.1	Test Methodology	114
4.8.2	Test results	114
4.9	Maximum Permissible Exposure	116
4.9.1	Test Methodology	116
4.9.2	RF Exposure Limit	116
4.9.3	EUT Operating Condition	117
4.9.4	Classification	117
4.9.5	Test Results	117
4.9.6	Sample Calculation	117
5	Test Equipment List	118
5.1	Equipment List	118
6	EMC Test Plan	119
6.1	Introduction	119
6.2	Customer	119
6.3	Equipment Under Test (EUT)	120
6.4	Test Specifications	125

Index of Tables

Table 1: Summary of Test Results	9
Table 2: RF Output Power at the Antenna Port – Test Results – Non Beamforming	17
Table 3: RF Output Power at the Antenna Port – Test Results – Non Beamforming Continued	18
Table 4: RF Output Power at the Antenna Port – Test Results – Non Beamforming Continued	19
Table 5: RF Output Power at the Antenna Port – Test Results – Non Beamforming Continued	20
Table 6: RF Output Power at the Antenna Port – Test Results – Beamforming.....	21
Table 7: RF Output Power at the Antenna Port – Test Results – Beamforming Continued.....	22
Table 8: RF Output Power at the Antenna Port – Test Results – Beamforming Continued.....	23
Table 9: RF Output Power at the Antenna Port – Test Results – Beamforming Continued.....	24
Table 10: Occupied Bandwidth – Test Results.....	36
Table 11: Occupied Bandwidth – Test Results Continued.....	37
Table 12: Peak Power Spectral Density – Test Results – Non Beamforming	42
Table 13: Peak Power Spectral Density – Test Results – Non Beamforming Continued	43
Table 14: Peak Power Spectral Density – Test Results – Non Beamforming Continued	44
Table 15: Peak Power Spectral Density – Test Results – Non Beamforming Continued	45
Table 16: Peak Power Spectral Density – Test Results – Beamforming	46
Table 17: Peak Power Spectral Density – Test Results – Beamforming Continued	47
Table 18: Peak Power Spectral Density – Test Results – Beamforming Continued	48
Table 19: Peak Power Spectral Density – Test Results – Beamforming Continued	49
Table 20: Emissions at the Band-Edge – Test Results.....	62
Table 21: Emissions at the Band-Edge – Test Results Continued.....	63
Table 22: Transmit Spurious Emission at Band-Edge Requirements.....	81
Table 23: Transmit Spurious Emission at Band-Edge Requirements Continued.....	82
Table 24: AC Conducted Emissions – Test Results.....	106
Table 25: Frequency Stability – Test Results	112
Table 26: Voltage Variation – Test Results.....	114
Table 27: Customer Information	119
Table 28: Technical Contact Information.....	119
Table 29: EUT Specifications	120
Table 30: Antenna Information	121
Table 31: EUT Channel Power Specifications	122
Table 32: Interface Specifications	124
Table 33: Supported Equipment	124

Index of Tables

Table 34: Description of Sample used for Testing..... 124
Table 35: Description of Test Configuration used for Radiated Measurement..... 124
Table 36: Test Specifications 125

1 Executive Summary

1.1 Scope

This report is intended to document the status of conformance with the requirements of the CFR 47 Part 15.407 2016 and RSS 247: 2017 based on the results of testing performed on 05 Apr 2017 to 04 May 2017 on the Wi-Fi Router Model B010001 (USA), B010002 (IC) manufactured by eero inc. This report only applies to the specific samples tested under the stated test conditions. It is the responsibility of the manufacturer to assure that additional production units of this model are manufactured with identical or EMI equivalent electrical and mechanical components. This report is further intended to document changes and modifications to the EUT throughout its life cycle. All documentation will be included as a supplement.

1.2 Purpose

Testing was performed to evaluate the EMC performance of the EUT in accordance with the applicable requirements, procedures, and criteria defined in the application of regulations and application of standards listed in this report. The 5180 MHz to 5240 MHz frequency band is covered in this document.

1.3 Summary of Test Results

Table 1: Summary of Test Results

Test	Test Method ANSI C63.10	Test Parameters (Measured)	Result
Spurious Emission in Transmitted Mode	CFR47 15.209, CFR47 15.407 (b), 2.1053, 2.1057, RSS-GEN Sect.8.9, RSS 247 Sect. 6.2.1.2	Class B	Complied
Restricted Bands of Operation	CFR47 15.205, RSS GEN Sect.8.10	Class B	Complied
AC Power Conducted Emission	CFR47 15.207, RSS-GEN Sect.8.8	Class B	Complied
Occupied Bandwidth	CFR47 15.407 (a), 2.1049, RSS GEN Sect.6.6	See plots	Complied
Maximum Output Power	CFR47 15.407 (a), 2.1046 [see note 2]	27.19 dBm (11a mode) 27.88 dBm (HT 20) 28.94 dBm (HT 40) 29.05 dBm (VHT 40) 19.99 dBm (VHT80)	Complied
Maximum Output Power	RSS 247 Sect.6.2.1.1 [see note 2]	36.64 mW (11a mode) 38.45 mW (HT 20) 61.34 mW (HT 40) 61.88 mW (VHT 40) 65.77 mW (VHT80)	Complied
Peak Power Spectral Density	CFR47 15.407 (a)	< 17 dBm/MHz	Complied
Peak Power Spectral Density	RSS 247 Sect.6.2.1.1	< 10 dBm/MHz (e.i.r.p)	Complied
Conducted Emission – Antenna Port	CFR47 15.407 (b), 2.1051, 2.1057, RSS 247 Sect.6.2.2.2	30 MHz - 40 GHz < -27 dBm/MHz	Complied
Frequency Stability	CFR47 15.407 (g), 2.1055, RSS GEN Sect. 6.11	±20 ppm	Complied
RF Exposure	CFR47 15.407 (f), 2.1091 RSS-102 Issue 5	General Population	Complied

Note: 1. This test report covers 5150 MHz to 5250MHz band.
 2. Measurements are conducted for 2x2 MIMO total power non-beamforming.

1.4 Special Accessories

No special accessories were necessary in order to achieve compliance.

1.5 Equipment Modifications

None

2 Laboratory Information

2.1 Accreditations & Endorsements

2.1.1 US Federal Communications Commission



TUV Rheinland of North America at 1279 Quarry Ln, Pleasanton, CA 94566 is recognized by the commission for performing testing services for the general public on a fee basis. These laboratory test facilities have been fully described in reports submitted to and accepted by the FCC (US1131). The laboratory scope of accreditation includes: Title 47 CFR Parts 15, 18, and 90. The accreditation is updated every 3 years.

2.1.2 NIST / A2LA



TUV Rheinland of North America is accredited by the National Voluntary Laboratory Accreditation Program, which is administered under the auspices of the National Institute of Standards and Technology. The laboratory has been assessed and accredited in accordance with ISO Guide 17025:1999 and ISO 9002 (Lab Code Testing Cert #3331.02). The scope of laboratory accreditation includes emission and immunity testing. The accreditation is updated annually.

2.1.3 Canada – Industry Canada



TUV Rheinland of North America at the 1279 Quarry Ln, Pleasanton, CA 94566 address is accredited by Industry Canada for performing testing services for the general public on a fee basis. This laboratory test facilities have been fully described in reports submitted to and accepted by Industry Canada (File Number 2932M). This reference number is the indication to the Industry Canada Certification Officers that the site meets the requirements of RSS 212, Issue 1 (Provisional). The accreditation is updated every 3 years.

2.1.4 Japan – VCCI



The Voluntary Control Council for Interference by Information Technology Equipment (VCCI) is a group that consists of Information Technology Equipment (ITE) manufacturers and EMC test laboratories. The purpose of the Council is to take voluntary control measures against electromagnetic interference from Information Technology Equipment, and thereby contribute to the development of a socially beneficial and responsible state of affairs in the realm of Information Technology Equipment in Japan. TUV Rheinland of North America at 1279 Quarry Ln, Pleasanton, CA 94566 has been assessed and approved in accordance with the Regulations for Voluntary Control Measures.

VCCI Registration No. for Pleasanton: A-0261

2.1.5 Acceptance by Mutual Recognition Arrangement



The United States has an established agreement with specific countries under the Asia Pacific Laboratory Accreditation Corporation (APLAC) Mutual Recognition Arrangement. Under this agreement, all TUV Rheinland at 1279 Quarry Ln, Pleasanton, CA 94566 test results and test reports within the scope of the laboratory NIST / A2LA accreditation will be accepted by each member

country.

2.2 Test Facilities

All of the test facilities are located at 1279 Quarry Lane, Pleasanton, California 94566, USA. The 2305 Mission College, Santa Clara, 95054, USA location is considered a Pleasanton annex.

2.2.1 Emission Test Facility

The Semi-Anechoic chamber and AC Line Conducted measurement facility used to collect the radiated and conducted data has been constructed in accordance with ANSI C63.7:1992. The site has been measured in accordance with and verified to comply with the theoretical normalized site attenuation requirements of ANSI C63.4-2014, at a test distance of 3 and 5 meters. The site is listed with the FCC and accredited by A2LA (Lab Code Testing Cert #3331.02). The 3/5-meter semi-anechoic chamber used to collect the radiated data has been verified to comply with the theoretical normalized site attenuation requirements of ANSI C63.4-2014, at a test distance of 3 meter and 5 meters. A report detailing this site can be obtained from TUV Rheinland of North America.

2.2.2 Immunity Test Facility

ESD, EFT, Surge, PQF: These tests are performed in an environmentally controlled room with a 3.7 m x 4.8 m x 3.175 mm thick aluminum floor connected to PE ground.

For ESD testing, tabletop equipment is placed on an insulated mat with a surface resistivity of 10^9 Ohms/square on a 1.6 m x 0.8 m x 0.8 m high non-conductive table with a 3.175 mm aluminum top (Horizontal Coupling Plane). The HCP is connected to the main ground plane via a low impedance ground strap through two 470-k Ω resistors. The Vertical Coupling Plane consists of an aluminum plate 50 cm x 50 cm x 3.175 mm thick. The VCP is connected to the main ground plane via a low impedance ground strap through two 470-k Ω resistors.

For EFT, Surge, PQF, the HCP and VCP are removed.

RF Field Immunity testing is performed in a 7.3m x 4.3m x 4.1m anechoic chamber.

RF Conducted and Magnetic Field Immunity testing is performed on a 4.8m x 3.7m x 3.175mm thick aluminum ground plane.

All test areas allow a minimum distance of 1 meter from the EUT to walls or conducting objects.

2.3 Measurement Uncertainty

Two types of measurement uncertainty are expressed in this report, per *ISO Guide To The Expression Of Uncertainty In Measurement*, 1st Edition, 1995.

The *Combined Standard Uncertainty* is the standard uncertainty of the result of a measurement when that result is obtained from the values of a number of other quantities; it is equal to the positive square root of the sum of the variances or co-variances of these other quantities, weighted according to how the measurement result varies with changes in these quantities. The term *standard uncertainty* is the result of a measurement expressed as a standard deviation.

2.3.1 Sample Calculation – radiated & conducted emissions

The field strength is calculated by subtracting the Amplifier Gain and adding the Cable Loss and Antenna Correction Factor to the measured reading. The basic equation is as follows:

$$\text{Field Strength (dB}\mu\text{V/m)} = \text{RAW} - \text{AMP} + \text{CBL} + \text{ACF}$$

Where: RAW = Measured level before correction (dBμV)

AMP = Amplifier Gain (dB)

CBL = Cable Loss (dB)

ACF = Antenna Correction Factor (dB/m)

$$\mu\text{V/m} = 10^{\frac{\text{dB}\mu\text{V/m}}{20}}$$

Sample radiated emissions calculation @ 30 MHz

Measurement +Antenna Factor–Amplifier Gain+Cable loss=Radiated Emissions (dBuV/m)

$$25 \text{ dBuV/m} + 17.5 \text{ dB} - 20 \text{ dB} + 1.0 \text{ dB} = 23.5 \text{ dBuV/m}$$

2.3.2 Measurement Uncertainty

Per CISPR 16-4-2	U _{lab}	U _{cispr}
Radiated Disturbance @ 10 meters		
30 – 1,000 MHz	2.25 dB	4.51 dB
Radiated Disturbance @ 3 meters		
30 – 1,000 MHz	2.26 dB	4.52 dB
1 – 6 GHz	2.12 dB	4.25 dB
6 – 18 GHz	2.47 dB	4.93 dB
Conducted Disturbance @ Mains Terminals		
150 kHz – 30 MHz	1.09 dB	2.18 dB
Disturbance Power		
30 MHz – 300 MHz	3.92 dB	4.3 dB

Voltech PM6000A

The estimated combined standard uncertainty for harmonic current and flicker measurements is $\pm 5.0\%$.	Per CISPR 16-4-2 Methods
--	--------------------------

2.3.3 Measurement Uncertainty Immunity

The estimated combined standard uncertainty for ESD immunity measurements is $\pm 8.2\%$.	Per IEC 61000-4-2
The estimated combined standard uncertainty for radiated immunity measurements is ± 4.10 dB.	Per IEC 61000-4-3
The estimated combined standard uncertainty for conducted immunity measurements with CDN is ± 3.66 dB	Per IEC 61000-4-6
The estimated combined standard uncertainty for power frequency magnetic field immunity is $\pm 2.9\%$.	Per IEC 61000-4-8

Thermo KeyTek EMC Pro

The estimated combined standard uncertainty for EFT fast transient immunity measurements is $\pm 2.6\%$.
The estimated combined standard uncertainty for surge immunity measurements is $\pm 2.6\%$.
The estimated combined standard uncertainty for voltage variation and interruption measurements is $\pm 1.74\%$.

The expanded uncertainty at a level of 95% confidence is obtained by multiplying the combined standard uncertainty by a coverage factor of 2. Compliance criteria are not based on measurement uncertainty.

2.4 Calibration Traceability

All measurement instrumentation is traceable to the National Institute of Standards and Technology (NIST). Measurement method complies with ANSI/NCSL Z540-1-1994 and ISO Standard 17025:2005. Equipment calibration records are kept on file at the test facility.

3 Product Information

3.1 Product Description

The Model B010001 (USA), B010002 (IC), Wi-Fi Router, is a Wi-Fi router for the home capable of operating in the 2.4 GHz and 5 GHz frequency bands over 20 MHz, 40 MHz and 80 MHz channels.

3.2 Equipment Configuration

A description of the equipment configuration is given in the Test Plan Section. The EUT was tested as called for in the test standard and was configured and operated in a manner consistent with its intended use. The EUT was connected to rated power and allowed to reach intended operating conditions. The placement of the EUT system components was guided by the test standard and selected to represent typical installation conditions.

In the case of an EUT that can operate in more than one configuration, preliminary testing was performed to determine the configuration that produced maximum radiation.

The final configuration was selected to produce the worst case radiation for emissions testing and to place the EUT in the most susceptible state for immunity testing.

3.3 Operating Mode

A description of the operation mode is given in the Test Plan Section. In the case of an EUT that can operate in more than one state, preliminary testing was performed to determine the operating mode that produced maximum radiation.

The final operating mode was selected to produce the worst case radiation for emissions testing and to place the EUT in the most susceptible state for immunity testing.

3.4 Unique Antenna Connector

An intentional radiator shall be designed to ensure that no antenna other than that furnished by the responsible party shall be used with the device. The use of a permanently attached antenna or of an antenna that uses a unique coupling to the intentional radiator shall be considered sufficient to comply with the provisions of this Section. The manufacturer may design the unit so that a broken antenna can be replaced by the user, but the use of a standard antenna jack or electrical connector is prohibited. This requirement does not apply to carrier current devices or to devices operated under the provisions of CFR47 Parts 15.211, 15.213, 15.217, 15.219, or 15.221.

3.4.1 Results

The Wi-Fi Router has five FPCB antennas. The 5150 – 5250 MHz band uses Flex Printed Circuit Board (FPCB) dipole antennas, Antenna 1 and Antenna 3, and has maximum gain of + 4.58 dBi.

Refer to Table 30 for additional antenna information.

There are no additional antenna available.

4 Emissions

Testing was performed in accordance with CFR 47 Part 15.407: 2016 and RSS 247: 2017. These test methods are listed under the laboratory's A2LA Scope of Accreditation. This test measures the levels emanating from the EUT, thus evaluating the potential for the EUT to cause radio frequency interference to other electronic devices. Procedures described in section 8 of the standard were used.

4.1 Output Power Requirements

The maximum output power requirement is the maximum equivalent isotropic radiated power delivering at the transmitting antenna under specified conditions of measurements in the presence of modulation.

The maximum output power and harmonics shall not exceed CFR47 Part 15.407 (a):2016 and RSS 247 Sect. 6.2.1.1: 2017.

The maximum transmitted powers are

Part 15.407(a)(ii) – Band 5150-5250 MHz (conducted output power) : 1 W.

RSS 247 – Band 5150-5250 MHz (e.i.r.p.): 200 mW or $10 + 10\text{Log}(B)$ where B is the 99% emission bandwidth.

4.1.1 Test Method

The ANSIC63.10-2013 Section 12.3.2.2 conducted method was used to measure the channel power output. The preliminary investigation was performed at different data rate/ chain to determine the highest power output for each mode. The worst findings were conducted on 3 channels in each operating range per CFR47 Part 15.407(a) and RSS 247 Sect. 6.2.1.1; 5150 MHz to 5250 MHz. The worst mode results indicated below.

Test Setup:

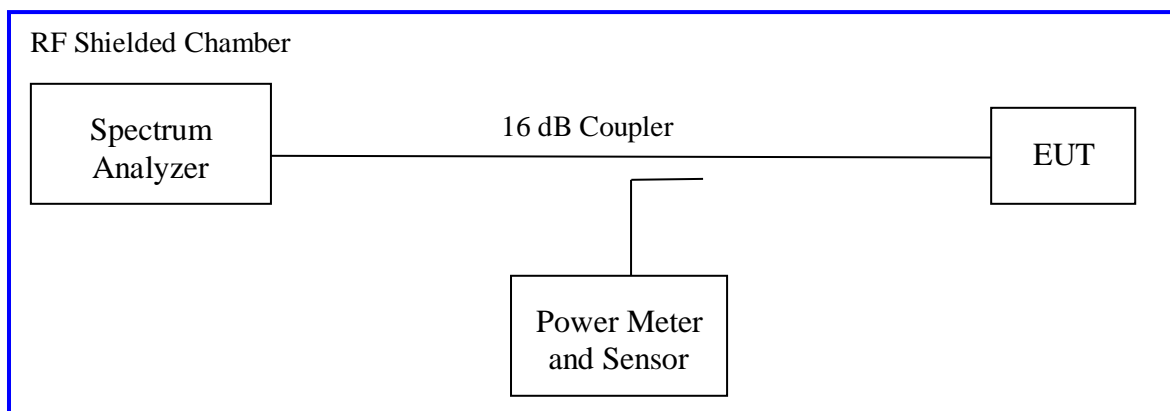

Method SA-1 of “KDB 789033 D02 – Guidelines for Compliance Testing of Unlicensed National Information Infrastructure (U-NII) Devices” applies since the EUT continuously transmit; where duty cycle is greater than 98%. Sample detector was used.

Each chain was measured individually and applied the measure-and-sum approach per KDB662911.

The total directional gain (8.67 dBi) was calculated by summing Antenna 1 (6.29 dBi) and Antenna 2 (4.97 dBi).

4.1.2 Results

As originally tested, the EUT was found to be compliant to the requirements of the test standard(s).

Table 2: RF Output Power at the Antenna Port – Test Results – Non Beamforming

Test Conditions: Conducted Measurement, Normal Temperature and Voltage Only					
Antenna Type: FPCB			Power Setting: See test plan		
Max. Directional Gain: Antenna 1 = + 3.01 dBi; Antenna 3 = + 4.58 dBi					
Signal State: Modulated at 100%.					
Ambient Temp.: 22° C			Relative Humidity: 39%		
802.11a (FCC Limit)					
Operating Channel (MHz)	Limit [dBm]	Ch0 [dBm]	Ch1 [dBm]	Total Power [dBm]	Margin [dB]
5180.00	30.00	22.43	23.39	25.93	-4.07
5240.00	30.00	23.52	24.80	27.19	-2.81
802.11a (RSS Limit)					
Operating Channel (MHz)	Power Limit [dBm]	Ch0 [dBm]	Ch1 [dBm]	Total Power [dBm]	Margin [dB]
5180.00	18.42	12.23	13.01	15.64	-2.78
5240.00	18.42	11.83	12.87	15.38	-3.04
Note: 1. The highest output power was observed at 6Mbps, 1 Data Stream. 2. The sum of Ch0 and Ch1 = Total Power. 3. RSS-247 Limit = 23 dBm – 4.58 dBi = 18.42 dBm. 4. Plots for all the measurements stated above were taken, to reduce complexity and bulkiness of the report Highlighted Plots are placed in the report.					

Table 3: RF Output Power at the Antenna Port – Test Results – Non Beamforming Continued

Test Conditions: Conducted Measurement, Normal Temperature and Voltage Only					
Antenna Type: FPCB			Power Setting: See test plan		
Max. Directional Gain: Antenna 1 = + 3.01 dBi; Antenna 3 = + 4.58 dBi					
Signal State: Modulated at 100%.					
Ambient Temp.: 22° C			Relative Humidity: 39%		
802.11n (FCC Limit)					
Operating Channel (MHz)	Limit [dBm]	Ch0 [dBm]	Ch1 [dBm]	Total Power [dBm]	Margin [dB]
5180.00	30.00	22.64	23.62	26.15	-3.85
5240.00	30.00	24.14	25.54	27.88	-2.12
802.11n (RSS Limit)					
Operating Channel (MHz)	Power Limit [dBm]	Ch0 [dBm]	Ch1 [dBm]	Total Power [dBm]	Margin [dB]
5180.00	18.42	12.44	13.22	15.85	-2.57
5240.00	18.42	11.90	12.97	15.47	-2.95
<p>Note: 1. The highest output power was observed at HT20 MCS0, 1 Data Stream. 2. The sum of Ch0 and Ch1 = Total Power. 3. RSS-247 Limit = 23 dBm – 4.58 dBi = 18.42 dBm. 4. Plots for all the measurements stated above were taken, to reduce complexity and bulkiness of the report Highlighted Plots are placed in the report.</p>					

Table 4: RF Output Power at the Antenna Port – Test Results – Non Beamforming Continued

Test Conditions: Conducted Measurement, Normal Temperature and Voltage Only					
Antenna Type: FPCB			Power Setting: See test plan		
Max. Directional Gain: Antenna 1 = + 3.01 dBi; Antenna 3 = + 4.58 dBi					
Signal State: Modulated at 100%.					
Ambient Temp.: 22° C			Relative Humidity: 39%		
802.11n (FCC Limit)					
Operating Channel (MHz)	Limit [dBm]	Ch0 [dBm]	Ch1 [dBm]	Total Power [dBm]	Margin [dB]
5190.00	30.00	19.15	20.01	22.60	-7.40
5230.00	30.00	25.09	26.69	28.94	-1.06
802.11n (RSS Limit)					
Operating Channel (MHz)	Power Limit [dBm]	Ch0 [dBm]	Ch1 [dBm]	Total Power [dBm]	Margin [dB]
5190.00	18.42	14.50	15.22	17.88	-0.54
5230.00	18.42	14.23	15.36	17.82	-0.60
<p>Note: 1. The highest output power was observed at HT40 MCS0, 1 Data Stream. 2. The sum of Ch0 and Ch1 = Total Power. 3. RSS-247 Limit = 23 dBm – 4.58 dBi = 18.42 dBm. 4. Plots for all the measurements stated above were taken, to reduce complexity and bulkiness of the report Highlighted Plots are placed in the report.</p>					

Table 5: RF Output Power at the Antenna Port – Test Results – Non Beamforming Continued

Test Conditions: Conducted Measurement, Normal Temperature and Voltage Only					
Antenna Type: FPCB			Power Setting: See test plan		
Max. Directional Gain: Antenna 1 = + 3.01 dBi; Antenna 3 = + 4.58 dBi					
Signal State: Modulated at 100%.					
Ambient Temp.: 22° C			Relative Humidity: 39%		
802.11ac (FCC Limit)					
Operating Channel (MHz)	Limit [dBm]	Ch0 [dBm]	Ch1 [dBm]	Total Power [dBm]	Margin [dB]
5190.00	30.00	18.66	19.46	22.08	-7.92
5230.00	30.00	25.20	26.80	29.05	-0.95
802.11ac (RSS Limit)					
Operating Channel (MHz)	Power Limit [dBm]	Ch0 [dBm]	Ch1 [dBm]	Total Power [dBm]	Margin [dB]
5190.00	18.42	14.48	15.31	17.92	-0.50
5230.00	18.42	14.19	15.37	17.81	-0.61
Note: The highest output power was observed at VHT40 MCS0, 1 Data Stream.					
802.11ac (FCC Limit)					
Operating Channel (MHz)	Limit [dBm]	Ch0 [dBm]	Ch1 [dBm]	Total Power [dBm]	Margin [dB]
5210	30.00	15.34	18.35	19.99	-10.01
802.11ac (RSS Limit)					
Operating Channel (MHz)	Limit [dBm]	Ch0 [dBm]	Ch1 [dBm]	Total Power [dBm]	Margin [dB]
5210	18.42	14.65	15.66	18.18	-0.24
Note: 1. The highest output power was observed at VHT80 MCS0, 1 Data Stream. 2. The sum of Ch0 and Ch1 = Total Power. 3. RSS-247 Limit = 23 dBm – 4.58 dBi = 18.42 dBm. 4. Plots for all the measurements stated above were taken, to reduce complexity and bulkiness of the report Highlighted Plots are placed in the report.					

Table 6: RF Output Power at the Antenna Port – Test Results – Beamforming

Test Conditions: Conducted Measurement, Normal Temperature and Voltage Only					
Antenna Type: FPCB			Power Setting: See test plan		
Total Directional Gain: + 6.84 dBi					
Signal State: Modulated at 100%.					
Ambient Temp.: 22° C			Relative Humidity: 39%		
802.11a (FCC Limit)					
Operating Channel (MHz)	Limit [dBm]	Ch0 [dBm]	Ch1 [dBm]	Total Power [dBm]	Margin [dB]
5180.00	29.16	22.43	23.39	25.93	-3.23
5240.00	29.16	22.47	23.80	26.17	-2.99
802.11a (RSS Limit)					
Operating Channel (MHz)	Power Limit [dBm]	Ch0 [dBm]	Ch1 [dBm]	Total Power [dBm]	Margin [dB]
5180.00	16.16	10.07	10.88	13.49	-2.66
5240.00	16.16	9.62	10.73	13.20	-2.96
<p>Note: 1. The highest output power was observed at 6Mbps, 2 Data Streams. 2. The sum of Ch0 and Ch1 = Total Power. 3. FCC Limit = 30 dBm – (6.84 dBi – 6 dBi) = 29.16 dBm 4. RSS-247 Limit = 23 dBm – 6.84 dBi = 16.16 dBm. 5. Plots for all the measurements stated above were taken, to reduce complexity and bulkiness of the report Highlighted Plots are placed in the report.</p>					

Table 7: RF Output Power at the Antenna Port – Test Results – Beamforming Continued

Test Conditions: Conducted Measurement, Normal Temperature and Voltage Only					
Antenna Type: FPCB			Power Setting: See test plan		
Total Directional Gain: + 6.84 dBi					
Signal State: Modulated at 100%.					
Ambient Temp.: 22° C			Relative Humidity: 39%		
802.11n (FCC Limit)					
Operating Channel (MHz)	Limit [dBm]	Ch0 [dBm]	Ch1 [dBm]	Total Power [dBm]	Margin [dB]
5180.00	29.16	22.64	23.62	26.15	-3.01
5240.00	29.16	24.14	25.54	27.88	-1.28
802.11n (RSS Limit)					
Operating Channel (MHz)	Power Limit [dBm]	Ch0 [dBm]	Ch1 [dBm]	Total Power [dBm]	Margin [dB]
5180.00	16.16	10.30	11.03	13.68	-2.48
5240.00	16.16	9.79	10.79	13.31	-2.84
<p>Note: 1. The highest output power was observed at HT20 MCS0, 2 Data Streams. 2. The sum of Ch0 and Ch1 = Total Power. 3. FCC Limit = 30 dBm – (6.84 dBi – 6 dBi) = 29.16 dBm 4. RSS-247 Limit = 23 dBm – 6.84 dBi = 16.16 dBm. 5. Plots for all the measurements stated above were taken, to reduce complexity and bulkiness of the report Highlighted Plots are placed in the report.</p>					

Table 8: RF Output Power at the Antenna Port – Test Results – Beamforming Continued

Test Conditions: Conducted Measurement, Normal Temperature and Voltage Only					
Antenna Type: FPCB			Power Setting: See test plan		
Total Directional Gain: + 6.84 dBi					
Signal State: Modulated at 100%.					
Ambient Temp.: 22° C			Relative Humidity: 39%		
802.11n (FCC Limit)					
Operating Channel (MHz)	Limit [dBm]	Ch0 [dBm]	Ch1 [dBm]	Total Power [dBm]	Margin [dB]
5190.00	29.16	19.15	20.01	22.60	-6.56
5230.00	29.16	25.09	26.69	28.94	-0.22
802.11n (RSS Limit)					
Operating Channel (MHz)	Power Limit [dBm]	Ch0 [dBm]	Ch1 [dBm]	Total Power [dBm]	Margin [dB]
5190.00	16.16	12.61	13.30	15.97	-0.19
5230.00	16.16	12.28	13.39	15.86	-0.30
<p>Note: 1. The highest output power was observed at HT40 MCS0, 2 Data Streams. 2. The sum of Ch0 and Ch1 = Total Power. 3. FCC Limit = 30 dBm – (6.84 dBi – 6 dBi) = 29.16 dBm 4. RSS-247 Limit = 23 dBm – 6.84 dBi = 16.16 dBm. 5. Plots for all the measurements stated above were taken, to reduce complexity and bulkiness of the report Highlighted Plots are placed in the report.</p>					

Table 9: RF Output Power at the Antenna Port – Test Results – Beamforming Continued

Test Conditions: Conducted Measurement, Normal Temperature and Voltage Only					
Antenna Type: FPCB			Power Setting: See test plan		
Total Directional Gain: + 6.84 dBi					
Signal State: Modulated at 100%.					
Ambient Temp.: 22° C			Relative Humidity: 39%		
802.11ac (FCC Limit)					
Operating Channel (MHz)	Limit [dBm]	Ch0 [dBm]	Ch1 [dBm]	Total Power [dBm]	Margin [dB]
5190.00	29.16	18.66	19.46	22.08	-7.08
5230.00	29.16	25.20	26.80	29.05	-0.11
802.11ac (RSS Limit)					
Operating Channel (MHz)	Power Limit [dBm]	Ch0 [dBm]	Ch1 [dBm]	Total Power [dBm]	Margin [dB]
5190.00	16.16	12.60	13.32	15.98	-0.18
5230.00	16.16	12.22	13.36	15.82	-0.34
Note: The highest output power was observed at VHT40 MCS0, 1 Data Stream.					
802.11ac (FCC Limit)					
Operating Channel (MHz)	Limit [dBm]	Ch0 [dBm]	Ch1 [dBm]	Total Power [dBm]	Margin [dB]
5210	29.16	15.34	18.35	19.99	-9.17
802.11ac (RSS Limit)					
Operating Channel (MHz)	Limit [dBm]	Ch0 [dBm]	Ch1 [dBm]	Total Power [dBm]	Margin [dB]
5210	16.16	12.14	13.18	15.69	-0.47
Note: 1. The highest output power was observed at VHT80 MCS0, 2 Data Streams. 2. The sum of Ch0 and Ch1 = Total Power. 3. FCC Limit = 30 dBm – (6.84 dBi – 6 dBi) = 29.16 dBm 4. RSS-247 Limit = 23 dBm – 6.84 dBi = 16.16 dBm. 5. Plots for all the measurements stated above were taken, to reduce complexity and bulkiness of the report Highlighted Plots are placed in the report.					

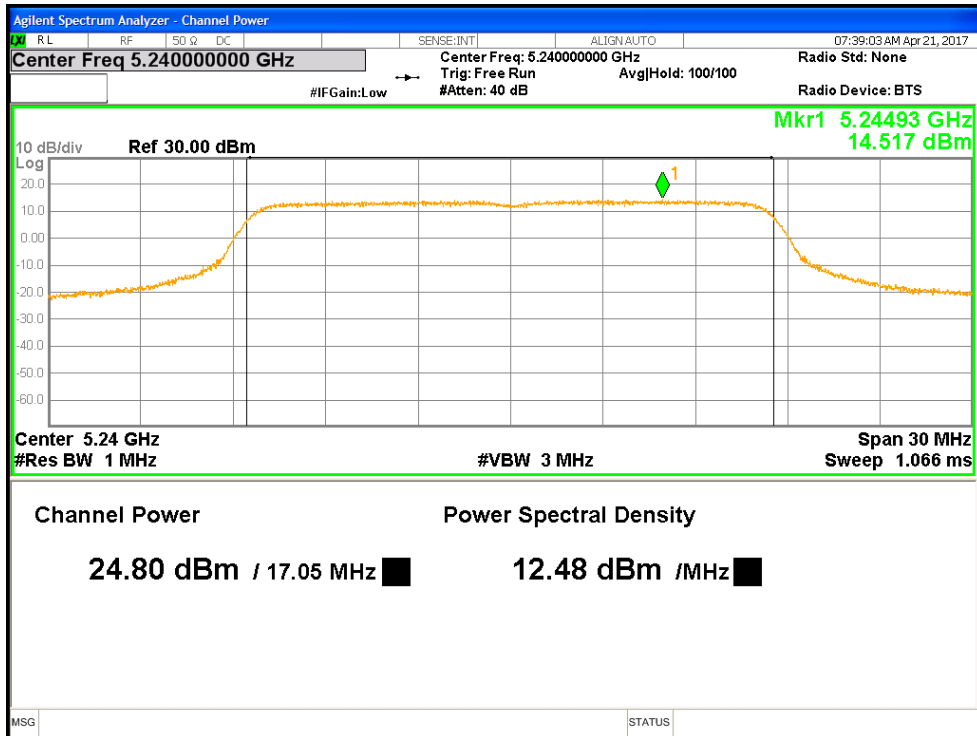

Figure 1: Non-Beamforming Max Transmitted Power (FCC), 5240 MHz at 11a, Chain 1

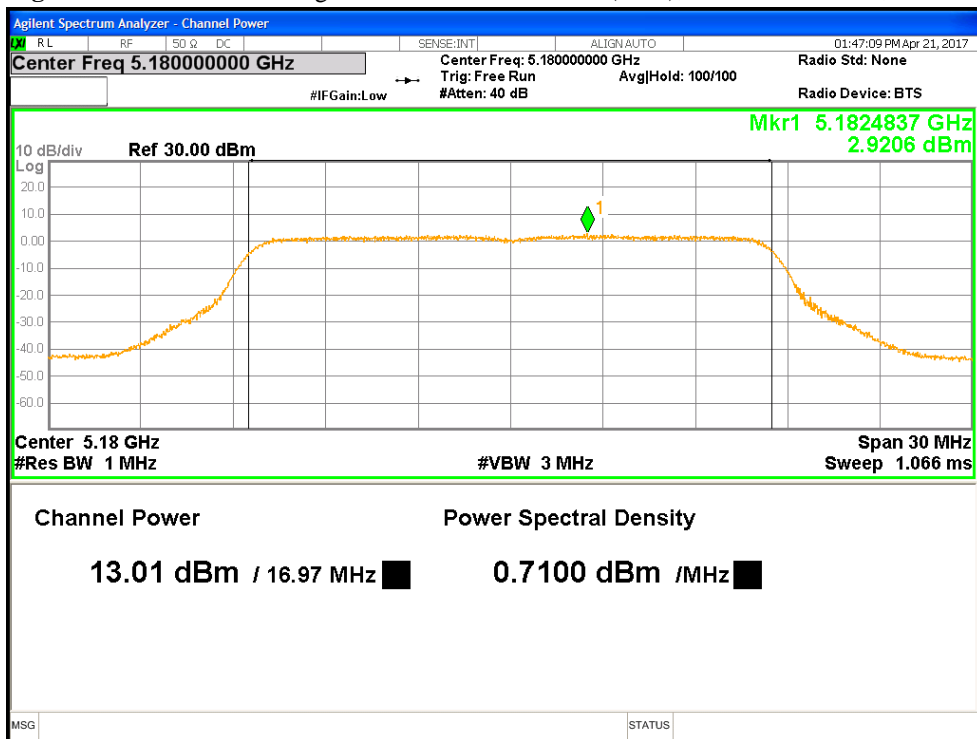

Figure 2: Non-Beamforming Max Transmitted Power (RSS), 5180 MHz at 11a, Chain 1

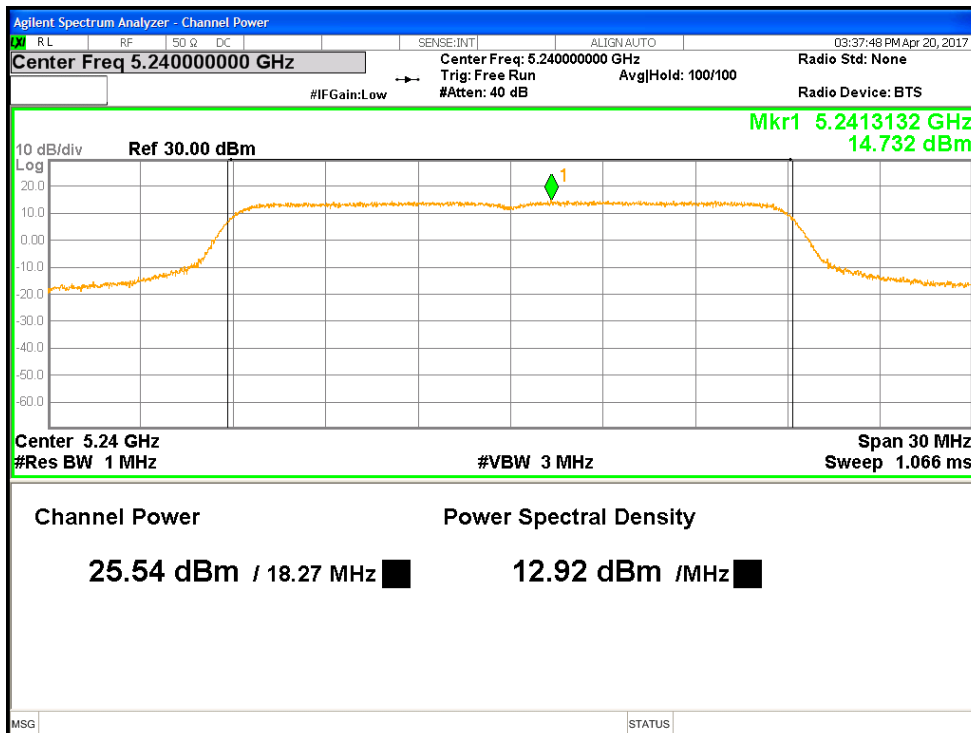

Figure 3: Non-Beamforming Max Transmitted Power (FCC), 5240 MHz at HT20, Chain 1

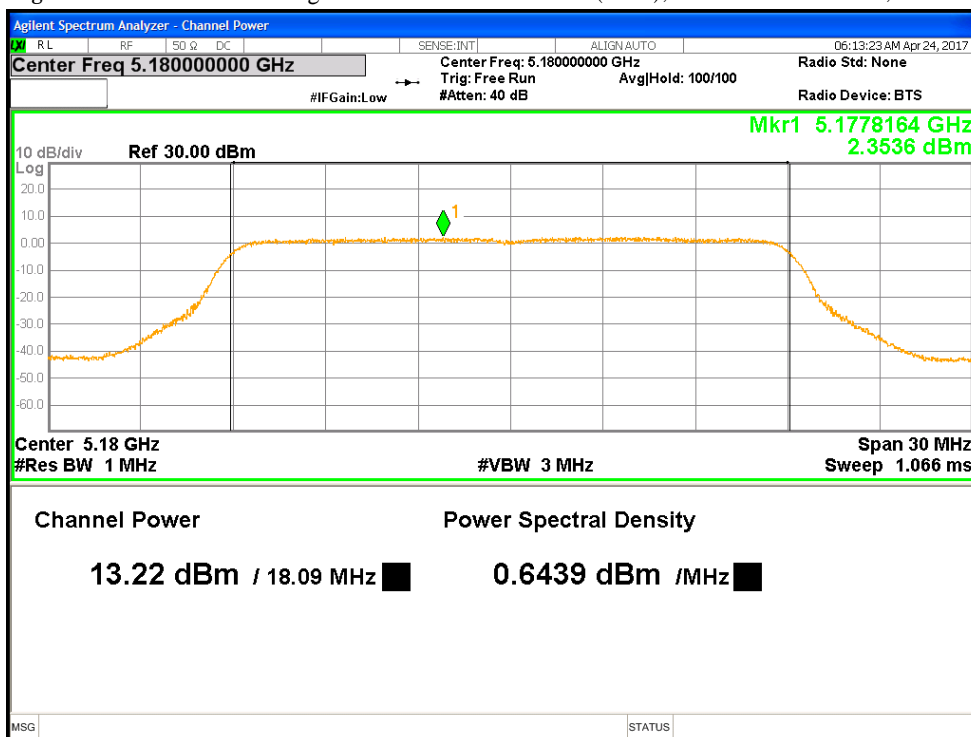

Figure 4: Non-Beamforming Max Transmitted Power (RSS), 5180 MHz at HT20, Chain 1

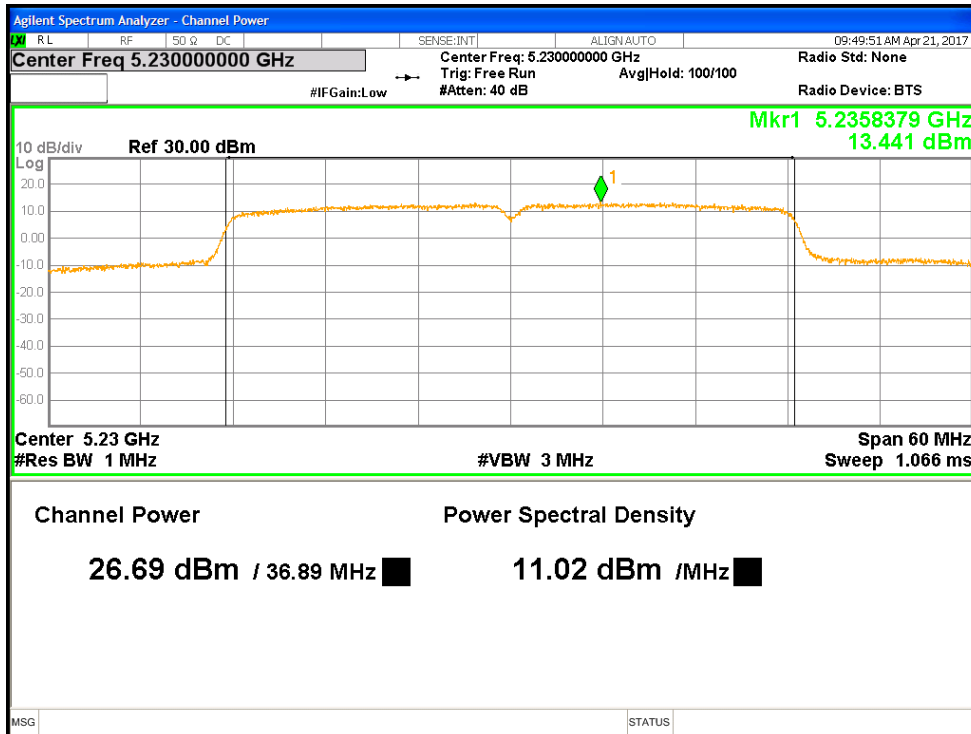

Figure 5: Non-Beamforming Max Transmitted Power (FCC), 5230 MHz at HT40, Chain 1

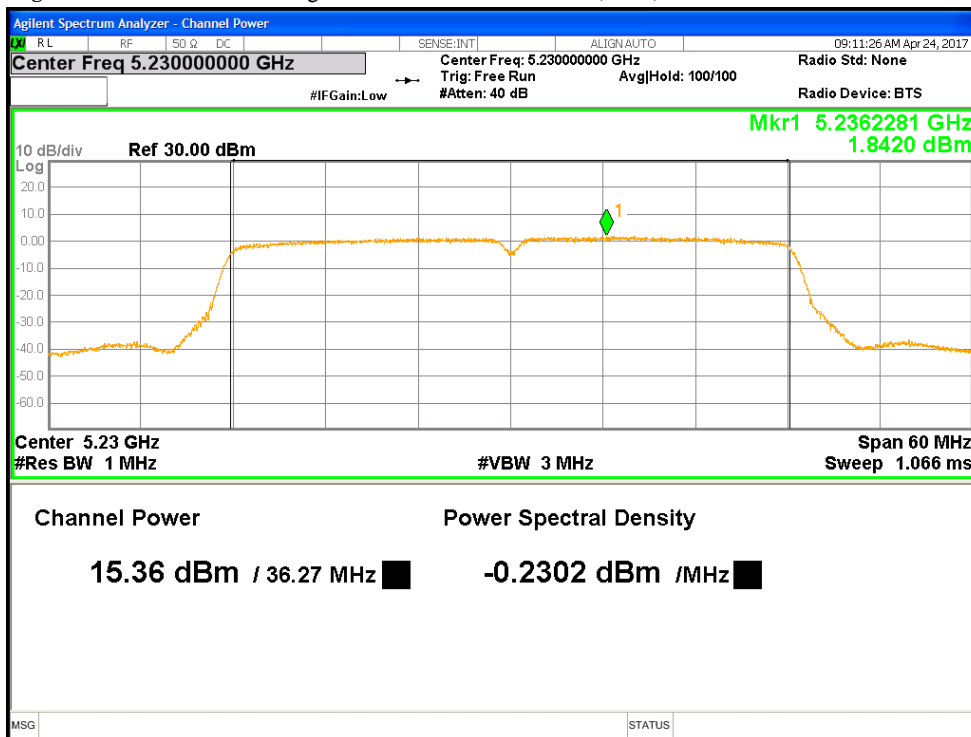

Figure 6: Non-Beamforming Max Transmitted Power (RSS), 5230 MHz at HT40, Chain 1

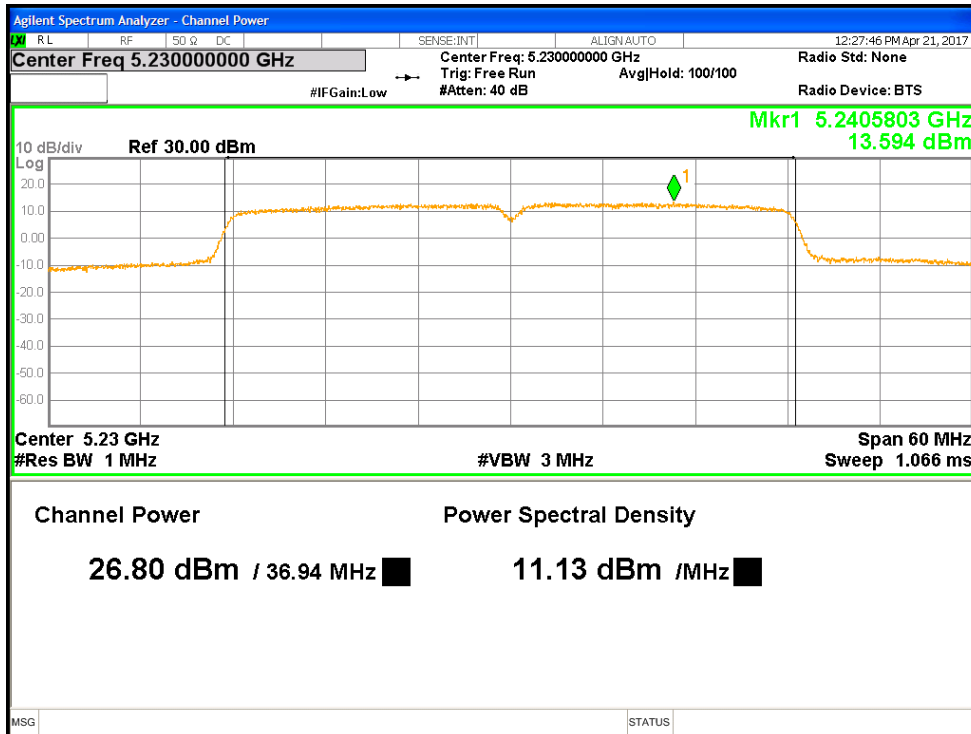

Figure 7: Non-Beamforming Max Transmitted Power (FCC), 5230 MHz at VHT40, Chain 1

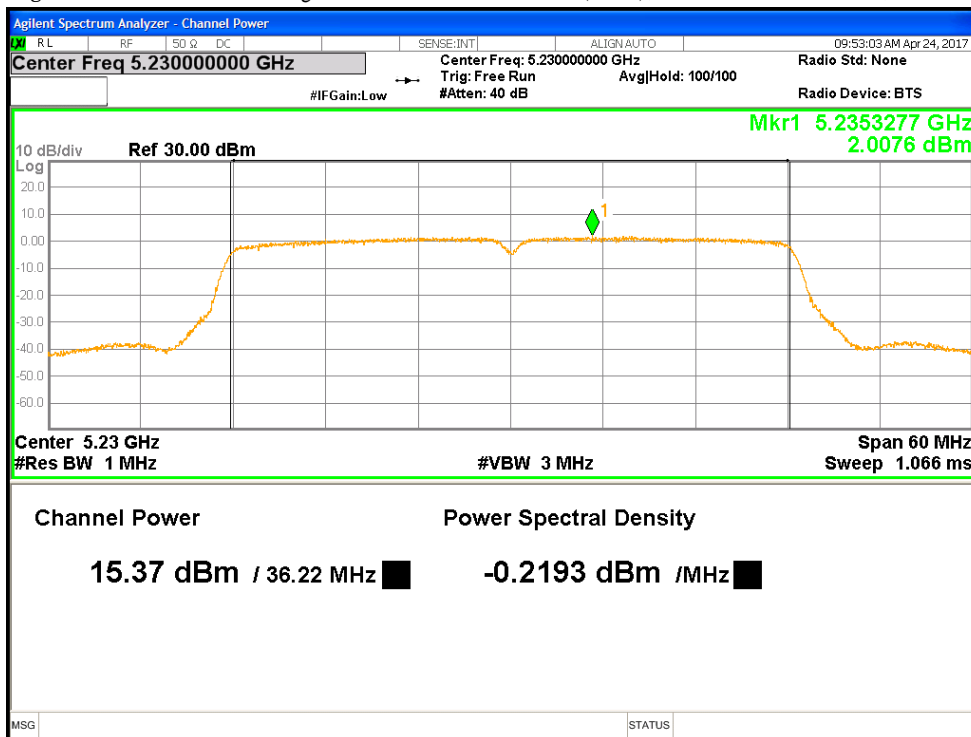

Figure 8: Non-Beamforming Max Transmitted Power (RSS), 5230 MHz at VHT40, Chain 1

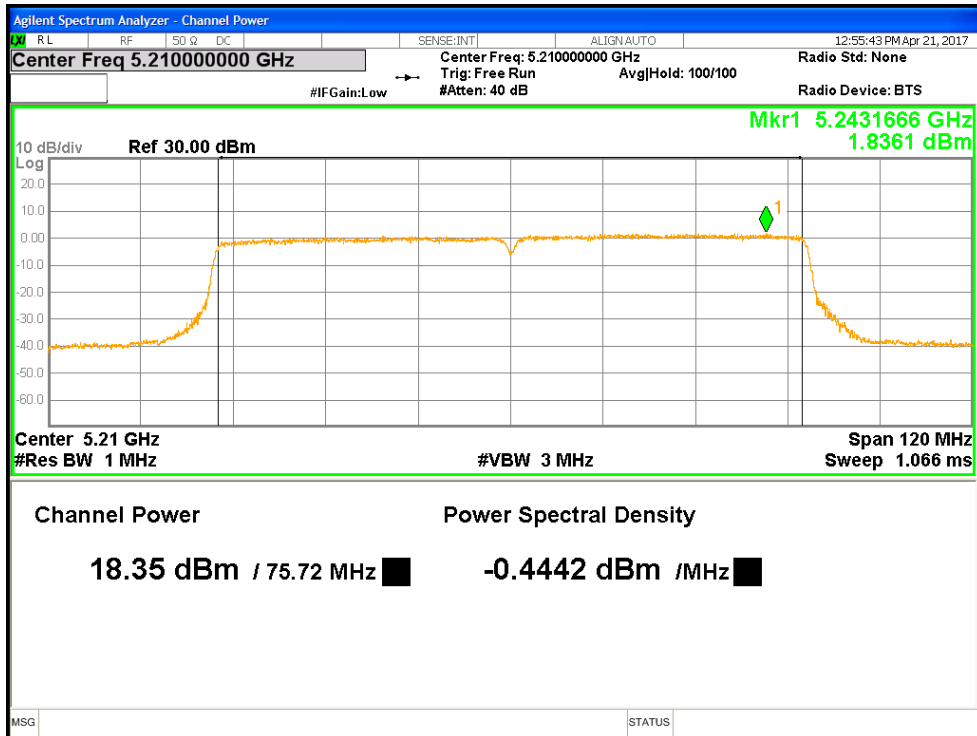

Figure 9: Non-Beamforming Max Transmitted Power (FCC), 5210 MHz at VHT80, Chain 1

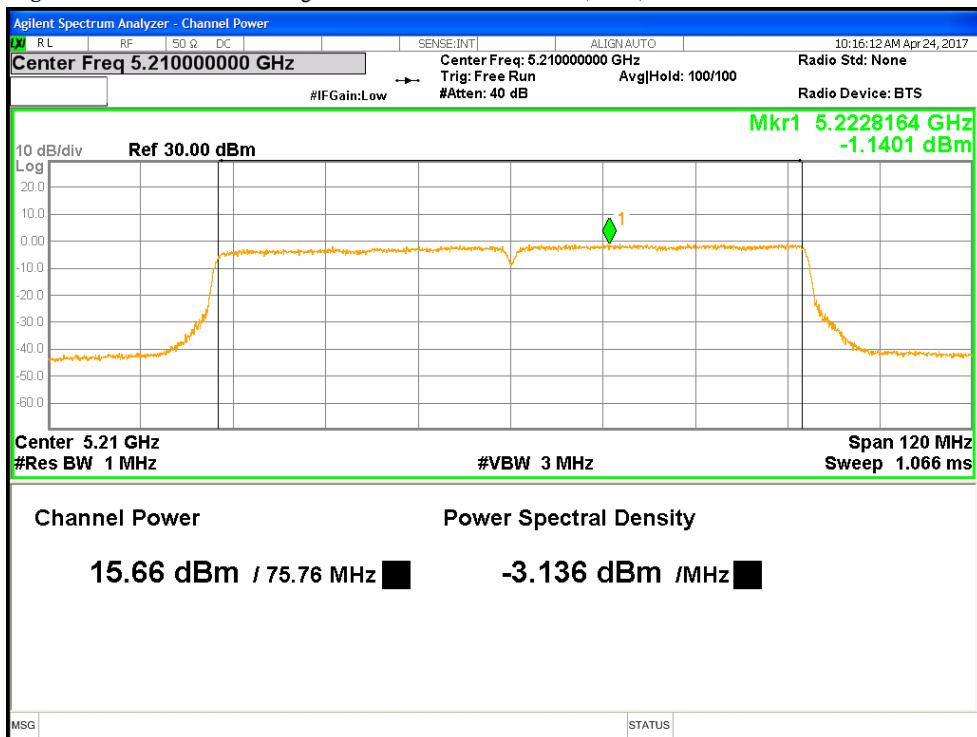

Figure 10: Non-Beamforming Max Transmitted Power (RSS), 5210 MHz at VHT80, Chain 0

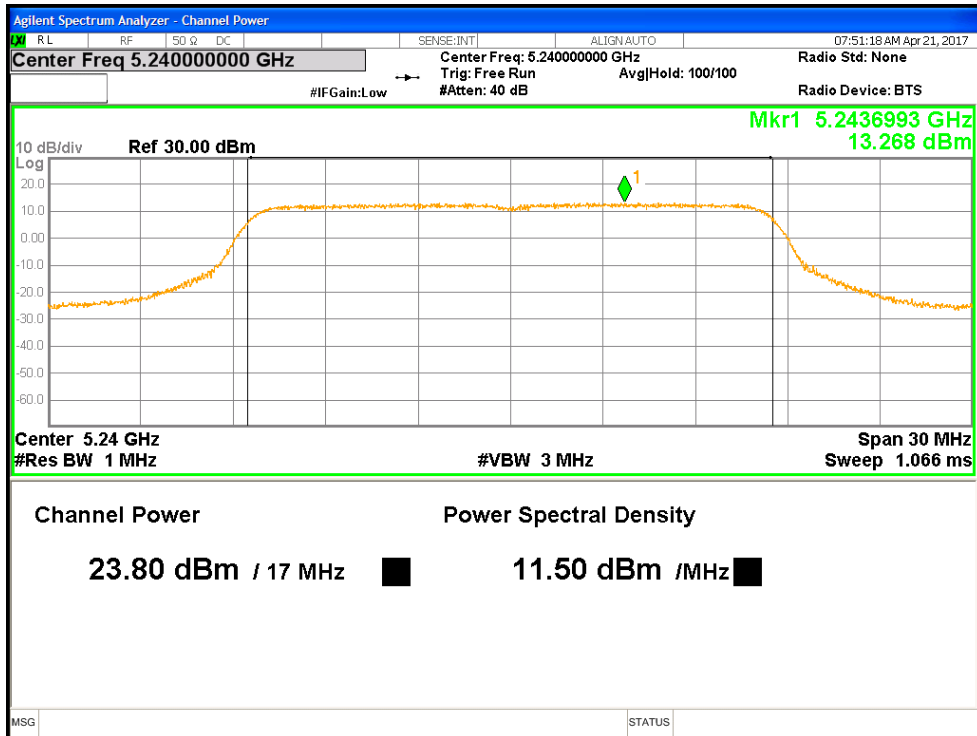

Figure 11: Beamforming Max Transmitted Power (FCC), 5240 MHz at 11a, Chain 1

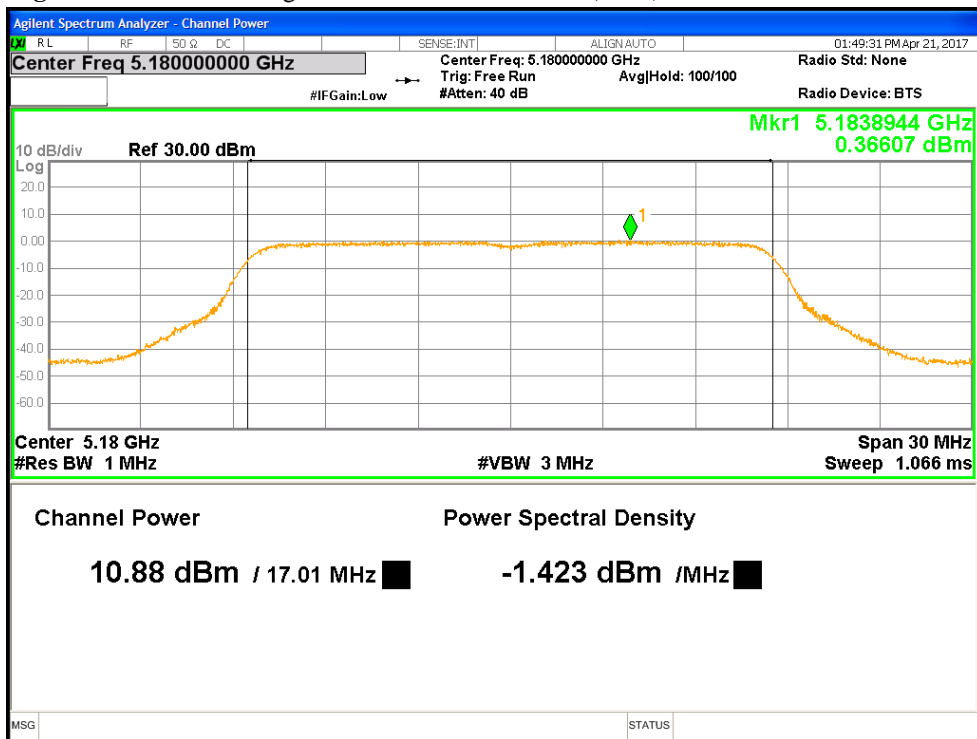

Figure 12: Beamforming Max Transmitted Power (RSS), 5180 MHz at 11a, Chain 1

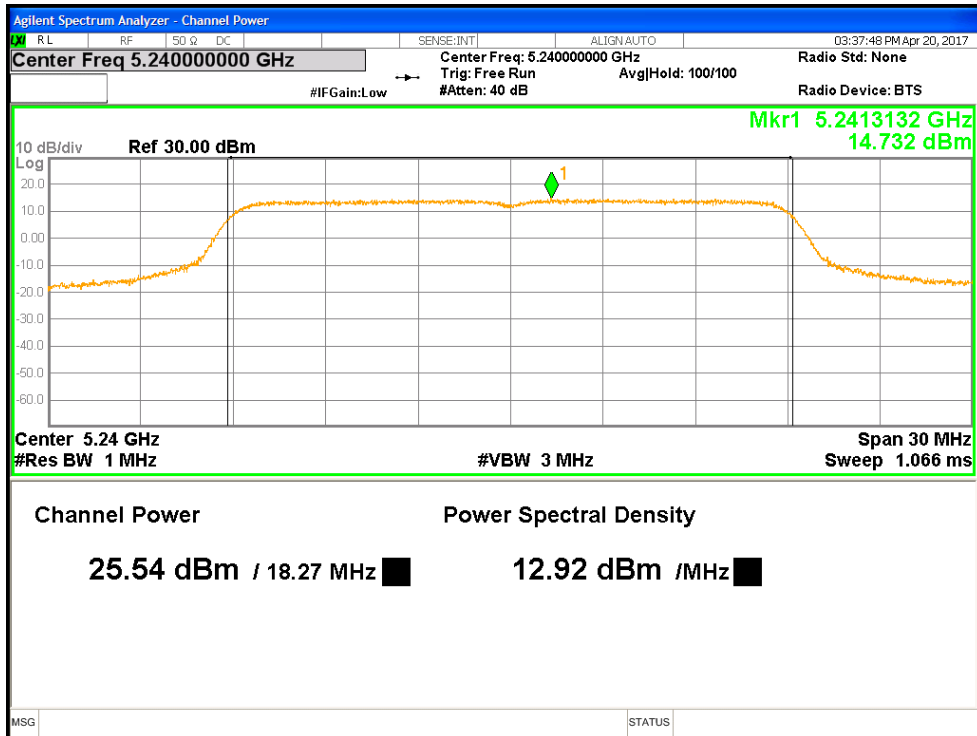

Figure 13: Beamforming Max Transmitted Power (FCC), 5240 MHz at HT20, Chain 1

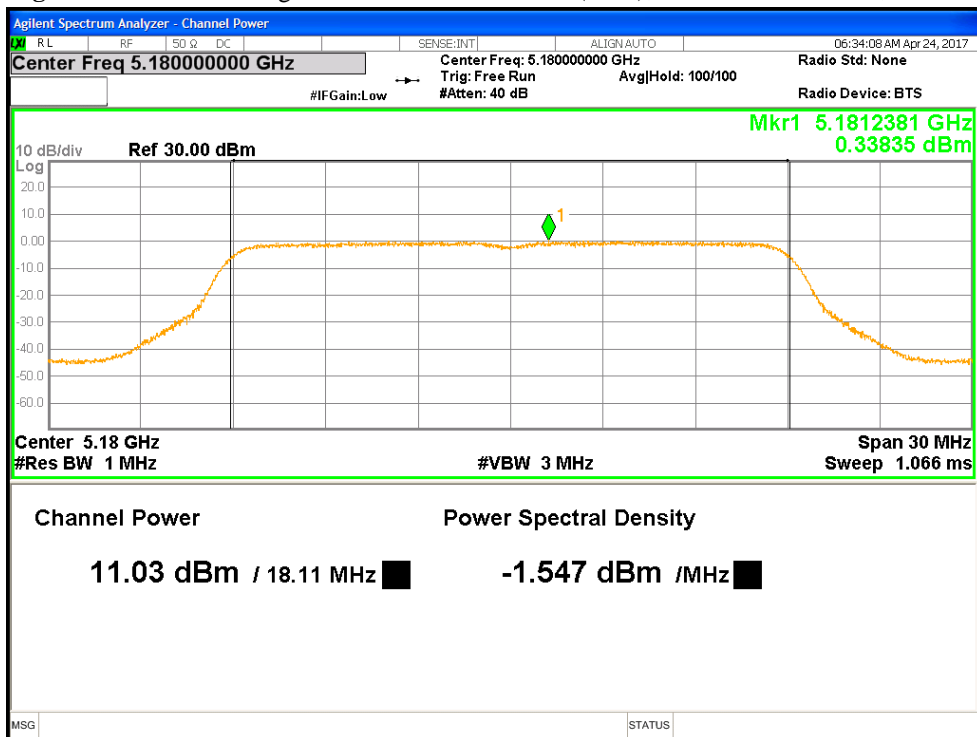

Figure 14: Beamforming Max Transmitted Power (RSS), 5180 MHz at HT20, Chain 1

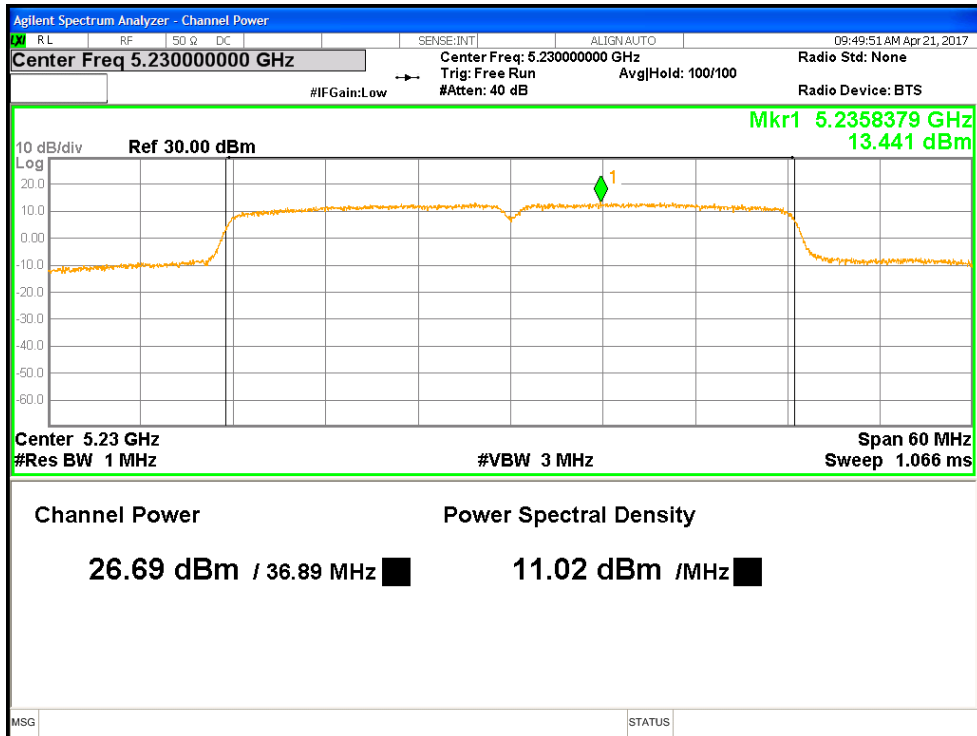

Figure 15: Beamforming Max Transmitted Power (FCC), 5230 MHz at HT40, Chain 1

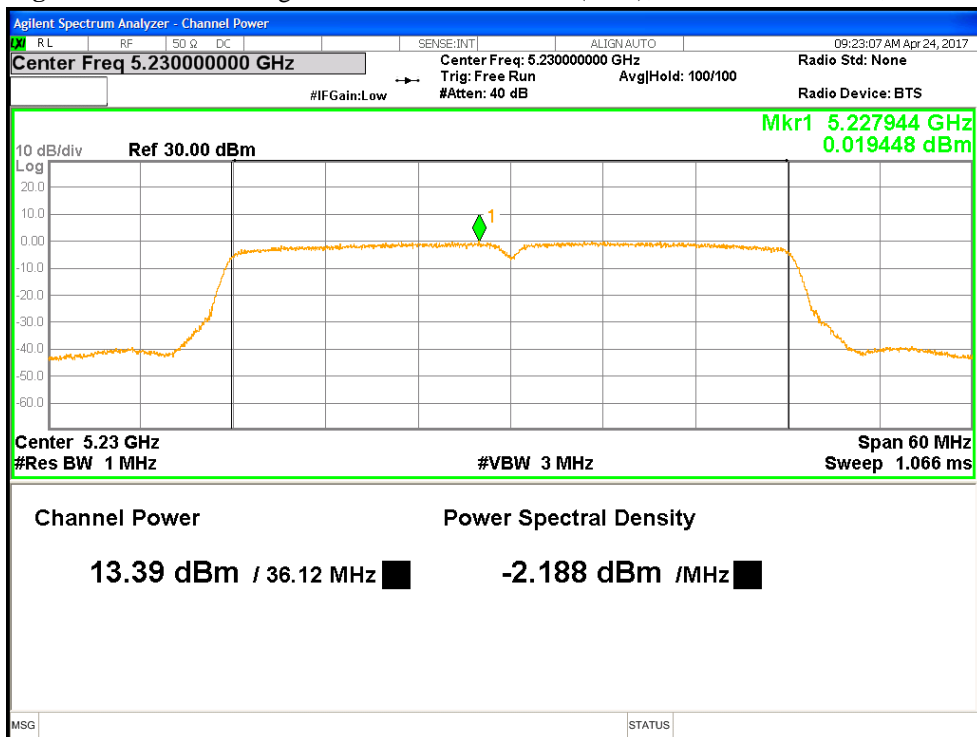

Figure 16: Beamforming Max Transmitted Power (RSS), 5230 MHz at HT40, Chain 1

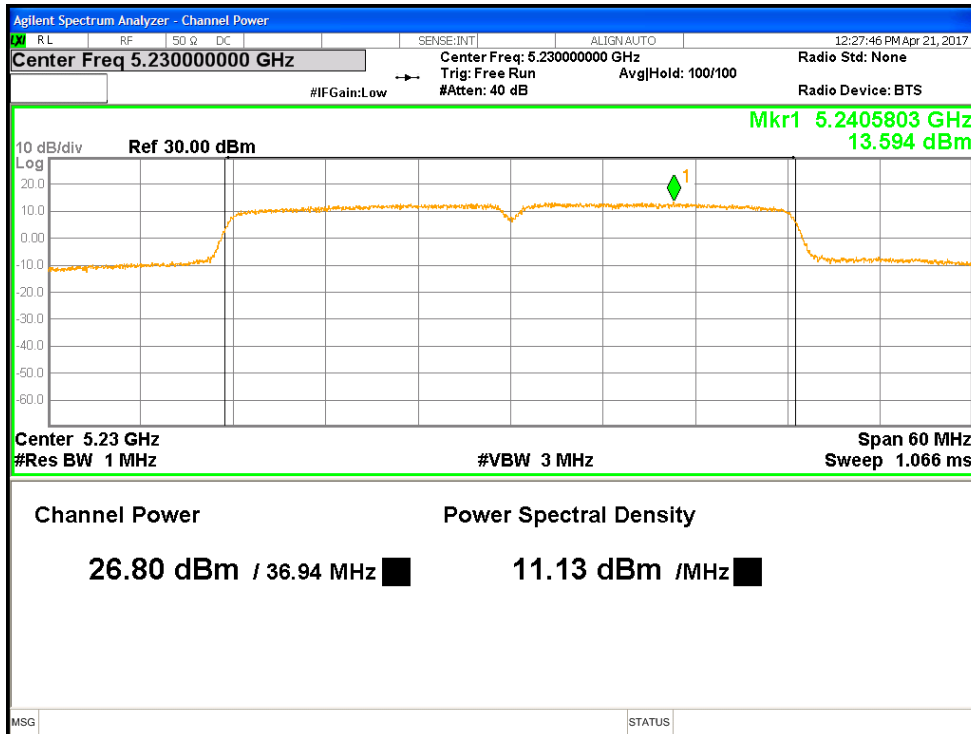

Figure 17: Beamforming Max Transmitted Power (FCC), 5230 MHz at VHT40, Chain 1

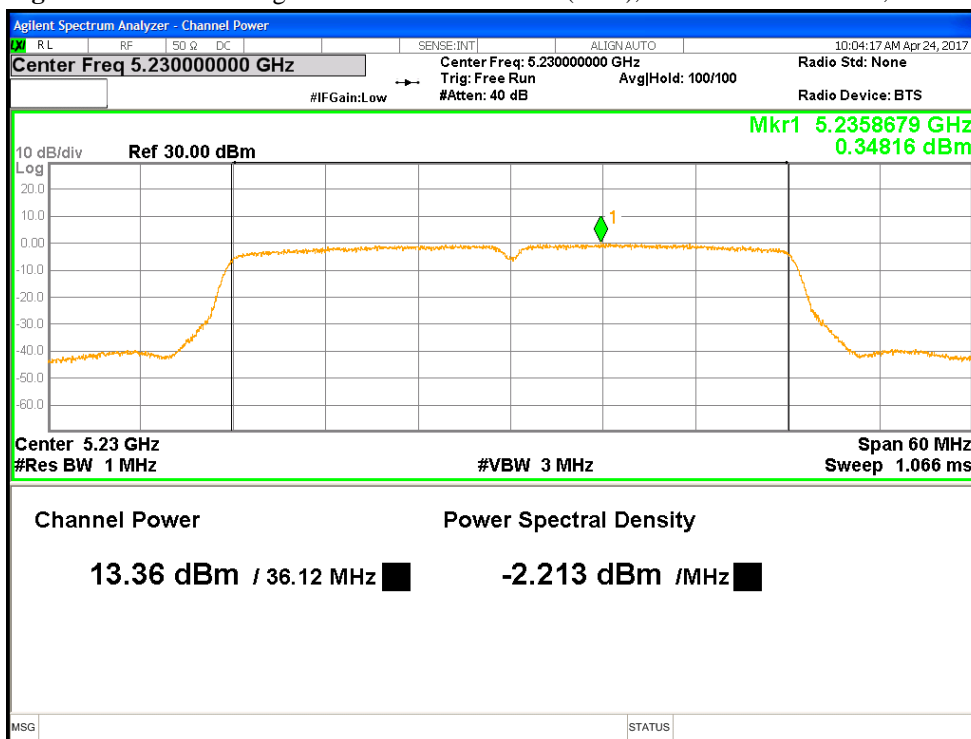

Figure 18: Beamforming Max Transmitted Power (RSS), 5230 MHz at VHT40, Chain 1

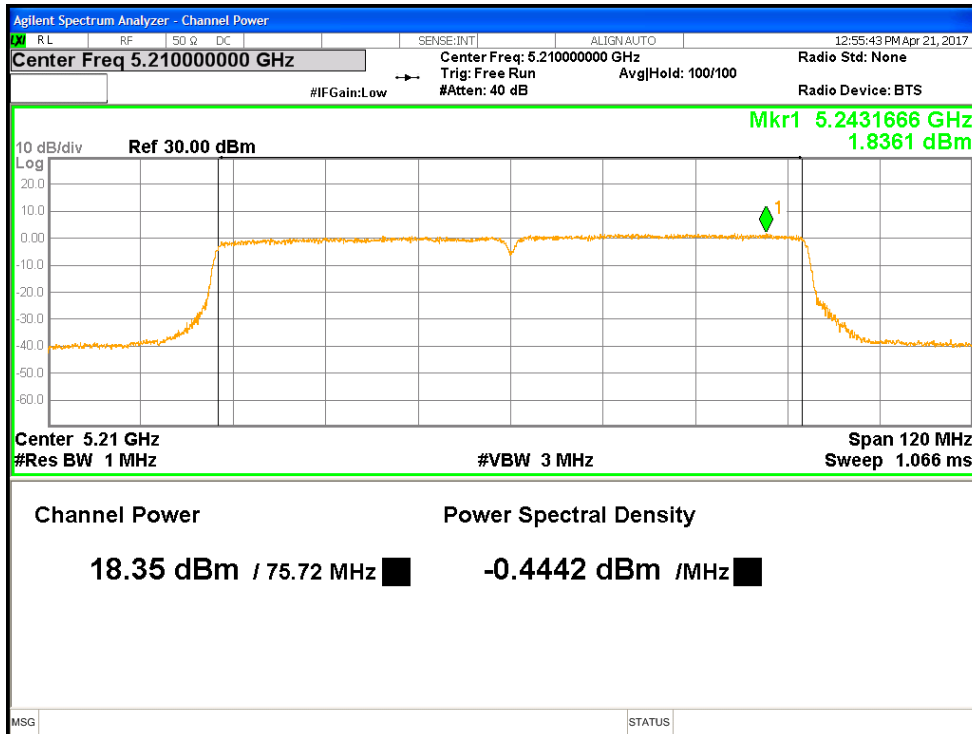

Figure 19: Beamforming Max Transmitted Power (FCC), 5210 MHz at VHT80, Chain 1

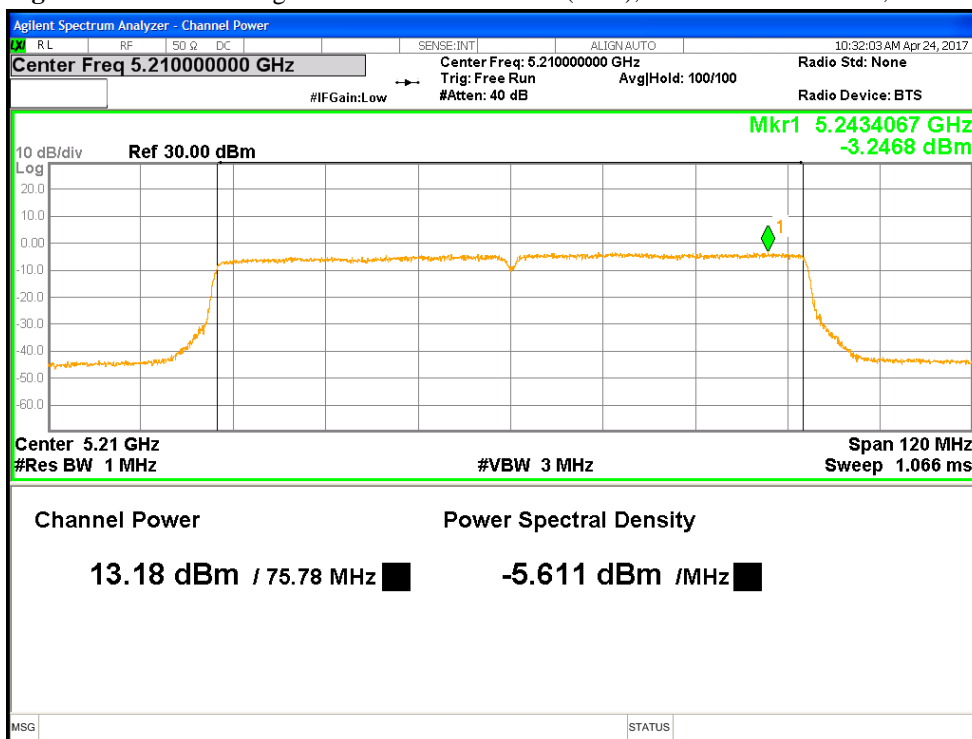

Figure 20: Beamforming Max Transmitted Power (RSS), 5210 MHz at VHT80, Chain 1

4.2 Occupied Bandwidth

The occupied bandwidth is measured at an amplitude level reduced from the reference level by a specified ratio. The reference level is the level of the highest amplitude signal observed from the transmitter at the fundamental frequency.

The 99% bandwidth is the bandwidth in which 99% of the transmitted power occupied.

The 26 dB bandwidth is defined the bandwidth of 26 dB from highest transmitted level of the fundamental frequency.

There is no restriction limits for the bandwidth. The 26 dB bandwidth was used to determine the limit for maximum conducted output power per CFR47 Part 15.407(a).

4.2.1 Test Method

The conducted method was used to measure the occupied bandwidth. The measurement was performed with modulation per CFR47 15.407(a) and RSS Gen Sect.6.6. The preliminary investigation was performed to find the narrowest 26 dB bandwidth for each operational mode at different data rates. This worst finding was performed on 3 channels in each operating frequency range; 5150 MHz to 5250 MHz. The worst results indicated below.

Test Setup:

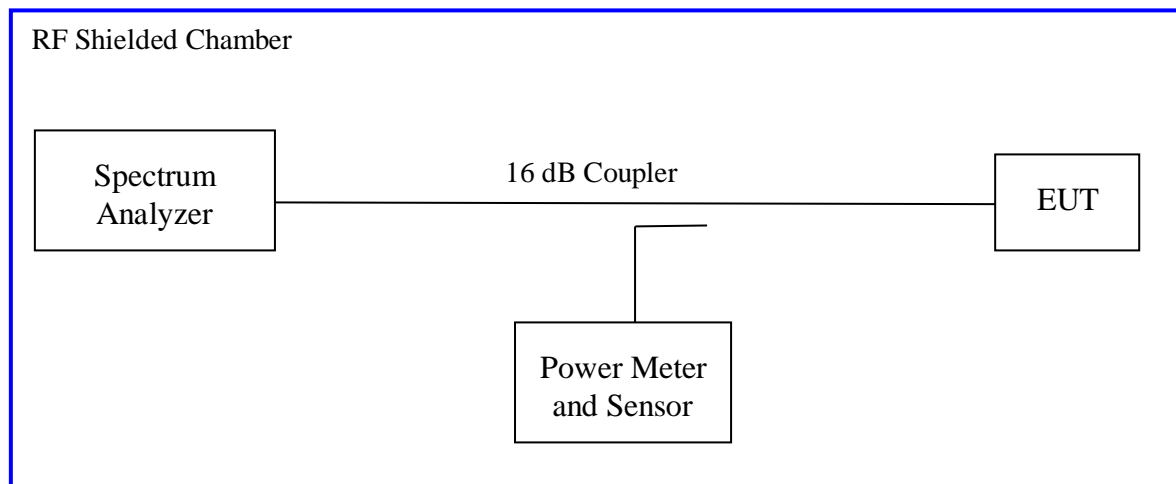

4.2.2 Results

These occupied bandwidth measurements were taken for references only.

Table 10: Occupied Bandwidth – Test Results

Test Conditions: Conducted Measurement, Normal Temperature and Voltage only				
Antenna Type: FPCB			Power Setting: See test plan	
Max. Directional Gain: Antenna 1 = + 3.01 dBi; Antenna 3 = + 4.58 dBi				
Total Directional Gain: + 6.84 dBi				
Signal State: Modulated at 100%.				
Ambient Temp.: 22° C			Relative Humidity: 39%	
802.11a				
Freq. (MHz)	26dB Bandwidth (MHz)		99% Bandwidth (MHz)	
	Ch0	Ch1	Ch0	Ch1
5180	18.97	19.08	16.443	16.414
5240	19.56	20.47	16.441	16.479
Note: 1. The bandwidth was measured at 6.0 Mbps. 2. Plots for all the measurements stated above were taken, to reduce complexity and bulkiness of the report Highlighted Plots are placed in the report.				
802.11n				
Freq. (MHz)	26dB Bandwidth (MHz)		99% Bandwidth (MHz)	
	Ch0	Ch1	Ch0	Ch1
5180	19.87	20.39	17.644	17.618
5240	20.16	21.39	17.612	17.684
Note: 1. The bandwidth was measured at HT20 MCS0, 1 Data Stream. 2. Plots for all the measurements stated above were taken, to reduce complexity and bulkiness of the report Highlighted Plots are placed in the report.				
802.11n				
Freq. (MHz)	26dB Bandwidth (MHz)		99% Bandwidth (MHz)	
	Ch0	Ch1	Ch0	Ch1
5190	39.04	39.29	35.964	35.978
5230	54.55	59.94	36.160	36.787
Note: 1. The bandwidth was measured at HT40 MCS0, 1 Data Stream. 2. Plots for all the measurements stated above were taken, to reduce complexity and bulkiness of the report Highlighted Plots are placed in the report.				

Table 11: Occupied Bandwidth – Test Results Continued

Test Conditions: Conducted Measurement, Normal Temperature and Voltage only				
Antenna Type: FPCB		Power Setting: See test plan		
Max. Directional Gain: Antenna 1 = + 3.01 dBi; Antenna 3 = + 4.58 dBi				
Total Directional Gain: + 6.84 dBi				
Signal State: Modulated at 100%.				
Ambient Temp.: 22° C		Relative Humidity: 39%		
802.11ac				
Freq. (MHz)	26dB Bandwidth (MHz)		99% Bandwidth (MHz)	
	Ch0	Ch1	Ch0	Ch1
5190	39.24	38.90	35.946	35.988
5230	53.80	59.63	36.094	36.620
Note: 1. The bandwidth was measured at VHT40 MCS0, 1 Data Stream. 2. Plots for all the measurements stated above were taken, to reduce complexity and bulkiness of the report Highlighted Plots are placed in the report.				
802.11ac				
Freq. (MHz)	26dB Bandwidth (MHz)		99% Bandwidth (MHz)	
	Ch0	Ch1	Ch0	Ch1
5210	83.58	82.38	75.675	75.756
Note: 1. The bandwidth was measured at VHT80 MCS0, 1 Data Stream. 2. Plots for all the measurements stated above were taken, to reduce complexity and bulkiness of the report Highlighted Plots are placed in the report.				

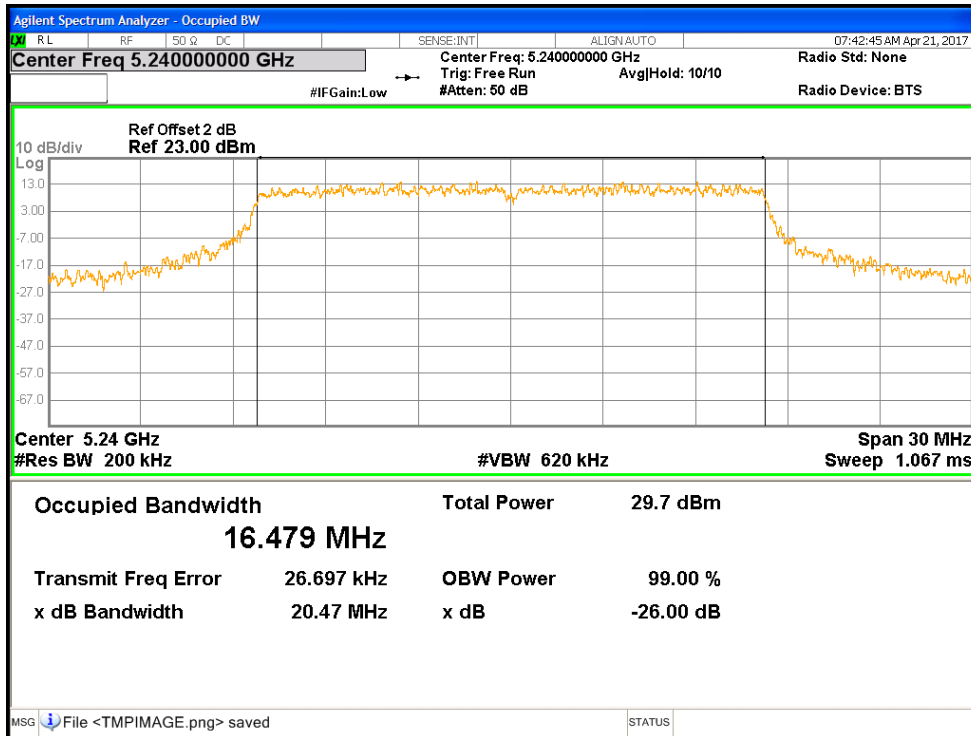

Figure 21: 26dB & 99% Occupied Bandwidth, 5240 MHz at 802.11a, Chain 1

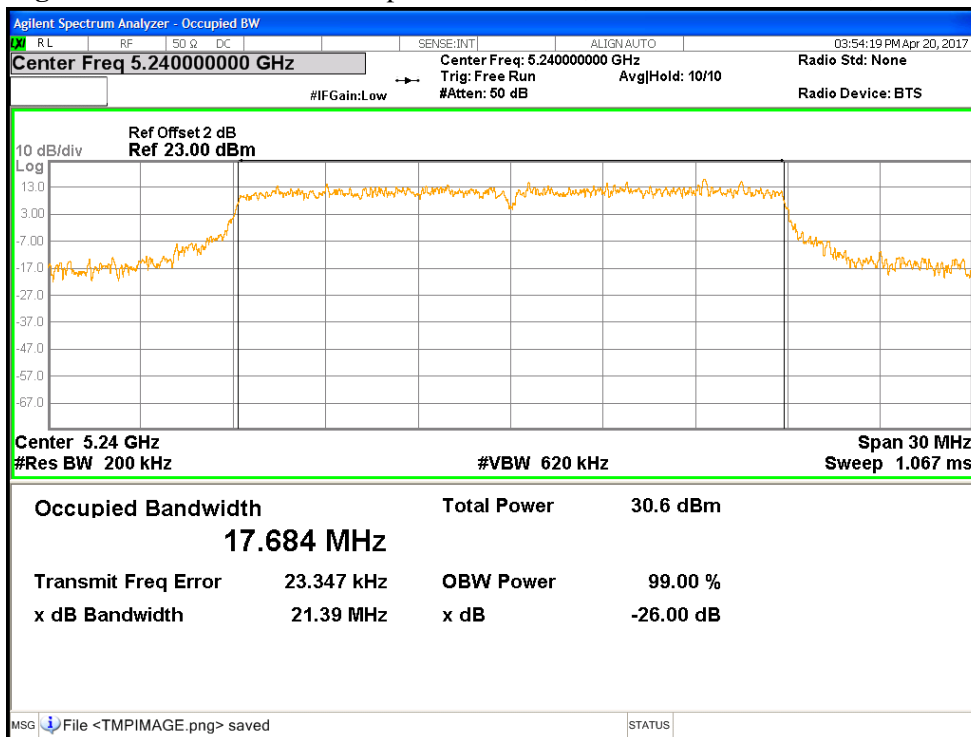

Figure 22: 26dB & 99% Occupied Bandwidth, 5240 MHz at HT20, Chain 1

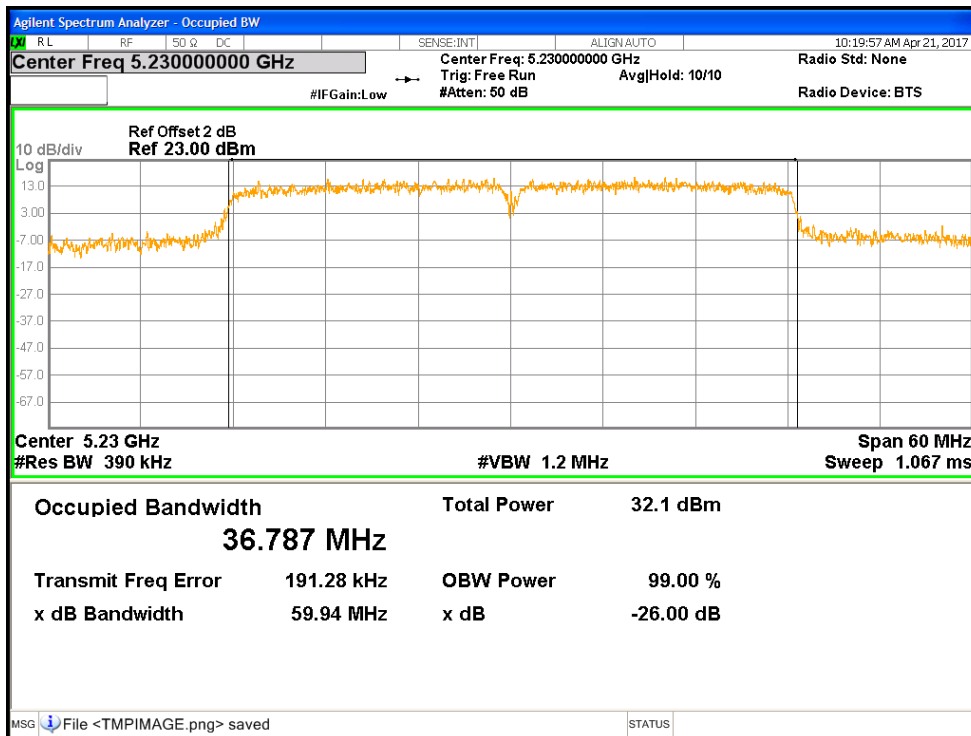

Figure 23: 26dB & 99% Occupied Bandwidth, 5230 MHz at HT40, Chain 1

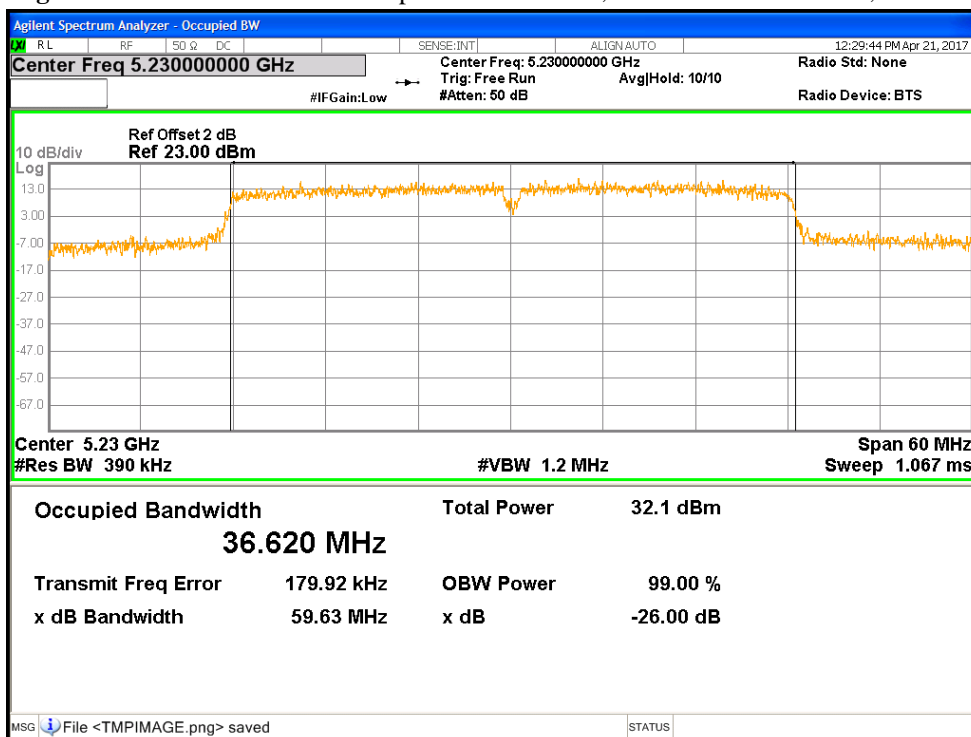

Figure 24: 26dB & 99% Occupied Bandwidth, 5230 MHz at VHT40, Chain 1

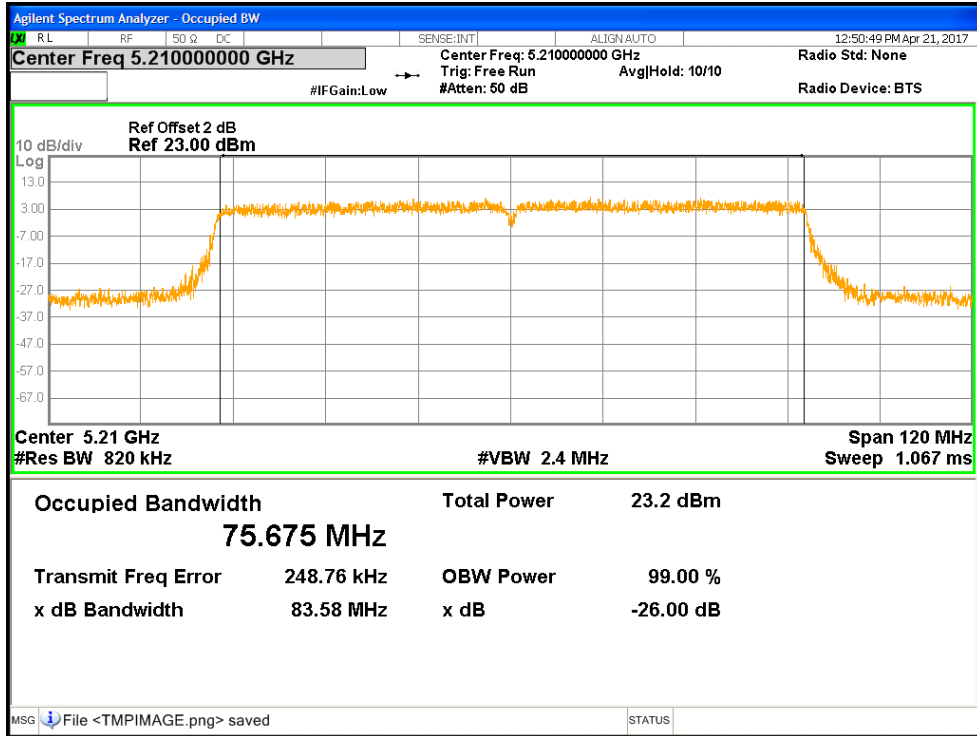

Figure 25: 26dB & 99% Occupied Bandwidth, 5210 MHz at VHT80, Chain 0

4.3 Peak Power Spectral Density

According to the CFR47 Part 15.407 (a) and RSS 247 Sect. 6.2.1.1 in the 5.15 – 5.25 GHz band, the spectral power density output of the antenna port shall be as followed listed below during any time interval of continuous transmission.

Part 15.407 (a): 17 dBm in any 1 MHz band

RSS 247 Section 6.2.1.1: 10 dBm in any 1 MHz band, E.I.R.P.

4.3.1 Test Method

The conducted method was used to measure the channel power output per ANSI C63.10-2013 Section 12.3.2.2. The measurement was performed with modulation per CFR47 Part 15.407 (a) and RSS 247 Sect. 6.2.1.1. The pre-evaluation was performed to find the worst modes. The worst findings were conducted on 3 channels in each operating frequency range of 5150 MHz to 5250 MHz. The worst sample result indicated below.

Test Setup:

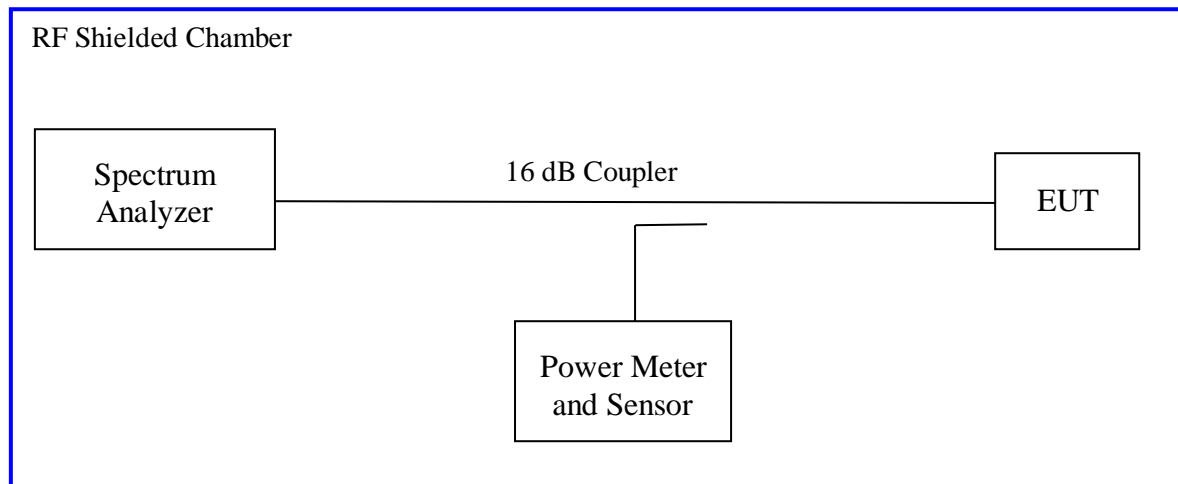

4.3.2 Results

As originally tested, the EUT was found to be compliant to the requirements of the test standard(s).

Table 12: Peak Power Spectral Density – Test Results – Non Beamforming

Test Conditions: Conducted Measurement, Normal Temperature and Voltage only					
Antenna Type: FPCB			Power Setting: See test plan		
Max. Directional Gain: Antenna 1 = + 3.01 dBi; Antenna 3 = + 4.58 dBi					
Signal State: Modulated at 100%.					
Ambient Temp.: 22° C			Relative Humidity: 39%		
802.11a (FCC Limit)					
Freq. (MHz)	Ch0 [dBm]	Ch1 [dBm]	Total PSD [dBm]	Limit [dBm]	Margin [dB]
5180	11.807	12.991	15.429	17.000	-1.571
5240	13.077	14.716	16.945	17.000	-0.055
802.11a (RSS Limit)					
Freq. (MHz)	Ch0 [dBm]	Ch1 [dBm]	Total PSD [dBm]	Limit [dBm]	Margin [dB]
5180	1.737	2.438	5.105	5.420	-0.315
5240	1.463	2.388	4.948	5.420	-0.472
Note: 1. The highest output power was observed at 6Mbps, 1 Data Stream. 2. The sum of Ch0 and Ch1 = Total PSD. 3. RSS-247 Limit = 10 dBm – 4.58 dBi = 5.42 dBm. 4. Plots for all the measurements stated above were taken, to reduce complexity and bulkiness of the report Highlighted Plots are placed in the report.					

Table 13: Peak Power Spectral Density – Test Results – Non Beamforming Continued

Test Conditions: Conducted Measurement, Normal Temperature and Voltage only					
Antenna Type: FPCB			Power Setting: See test plan		
Max. Directional Gain: Antenna 1 = + 3.01 dBi; Antenna 3 = + 4.58 dBi					
Signal State: Modulated at 100%.					
Ambient Temp.: 22° C			Relative Humidity: 39%		
802.11n (FCC Limit)					
Freq. (MHz)	Ch0 [dBm]	Ch1 [dBm]	Total PSD [dBm]	Limit [dBm]	Margin [dB]
5180	11.860	12.760	15.332	17.000	-1.668
5240	13.16	14.569	16.903	17.000	-0.097
802.11n (RSS Limit)					
Freq. (MHz)	Ch0 [dBm]	Ch1 [dBm]	Total PSD [dBm]	Limit [dBm]	Margin [dB]
5180	1.700	2.276	5.003	5.420	-0.417
5240	1.128	2.407	4.801	5.420	-0.619
<p>Note: 1. The highest output power was observed at HT20 MCS0, 1 Data Stream. 2. The sum of Ch0 and Ch1 = Total PSD. 3. RSS-247 Limit = 10 dBm – 4.58 dBi = 5.42 dBm. 4. Plots for all the measurements stated above were taken, to reduce complexity and bulkiness of the report Highlighted Plots are placed in the report.</p>					

Table 14: Peak Power Spectral Density – Test Results – Non Beamforming Continued

Test Conditions: Conducted Measurement, Normal Temperature and Voltage only					
Antenna Type: FPCB			Power Setting: See test plan		
Max. Directional Gain: Antenna 1 = + 3.01 dBi; Antenna 3 = + 4.58 dBi					
Signal State: Modulated at 100%.					
Ambient Temp.: 22° C			Relative Humidity: 39%		
Peak Power Spectral Density					
802.11n (FCC Limit)					
Freq. (MHz)	Ch0 [dBm]	Ch1 [dBm]	Total PSD [dBm]	Limit [dBm]	Margin [dB]
5190	6.714	5.402	9.093	17.000	-7.907
5230	12.063	13.144	15.631	17.000	-1.369
802.11n (RSS Limit)					
Freq. (MHz)	Ch0 [dBm]	Ch1 [dBm]	Total PSD [dBm]	Limit [dBm]	Margin [dB]
5190	0.934	1.897	4.439	5.420	-0.981
5230	0.564	1.839	4.235	5.420	-1.185
<p>Note: 1. The highest output power was observed at HT40 MCS0, 1 Data Stream. 2. The sum of Ch0 and Ch1 = Total PSD. 3. RSS-247 Limit = 10 dBm – 4.58 dBi = 5.42 dBm. 4. Plots for all the measurements stated above were taken, to reduce complexity and bulkiness of the report Highlighted Plots are placed in the report.</p>					

Table 15: Peak Power Spectral Density – Test Results – Non Beamforming Continued

Test Conditions: Conducted Measurement, Normal Temperature and Voltage only					
Antenna Type: FPCB			Power Setting: See test plan		
Max. Directional Gain: Antenna 1 = + 3.01 dBi; Antenna 3 = + 4.58 dBi					
Signal State: Modulated at 100%.					
Ambient Temp.: 22° C			Relative Humidity: 39%		
802.11ac (FCC Limit)					
Freq. (MHz)	Ch0 [dBm]	Ch1 [dBm]	Total PSD [dBm]	Limit [dBm]	Margin [dB]
5190	5.438	5.855	8.659	17.000	-8.341
5230	11.813	13.527	15.723	17.000	-1.277
802.11ac (RSS Limit)					
Freq. (MHz)	Ch0 [dBm]	Ch1 [dBm]	Total PSD [dBm]	Limit [dBm]	Margin [dB]
5190	1.102	2.186	4.671	5.420	-0.749
5230	0.407	1.794	4.138	5.420	-1.282
Note: The highest output power was observed at VHT40 MCS0, 1 Data Stream.					
802.11ac (FCC Limit)					
Freq. (MHz)	Ch0 [dBm]	Ch1 [dBm]	Total PSD [dBm]	Limit [dBm]	Margin [dB]
5210	-0.913	1.705	3.505	17.000	-13.495
802.11ac (RSS Limit)					
Freq. (MHz)	Ch0 [dBm]	Ch1 [dBm]	Total PSD [dBm]	Limit [dBm]	Margin [dB]
5210	-2.266	-0.852	1.480	5.420	-3.940
Note: 1. The highest output power was observed at VHT80 MCS0, 1 Data Stream. 2. The sum of Ch0 and Ch1 = Total PSD. 3. . RSS-247 Limit = 10 dBm – 4.58 dBi = 5.42 dBm. 4. Plots for all the measurements stated above were taken, to reduce complexity and bulkiness of the report Highlighted Plots are placed in the report.					

Table 16: Peak Power Spectral Density – Test Results – Beamforming

Test Conditions: Conducted Measurement, Normal Temperature and Voltage only					
Antenna Type: FPCB			Power Setting: See test plan		
Total Directional Gain: + 6.84 dBi					
Signal State: Modulated at 100%.					
Ambient Temp.: 22° C			Relative Humidity: 39%		
802.11a (FCC Limit)					
Freq. (MHz)	Ch0 [dBm]	Ch1 [dBm]	Total PSD [dBm]	Limit [dBm]	Margin [dB]
5180	11.807	12.991	15.429	16.160	-0.731
5240	11.753	13.261	15.550	16.160	-0.610
802.11a (RSS Limit)					
Freq. (MHz)	Ch0 [dBm]	Ch1 [dBm]	Total PSD [dBm]	Limit [dBm]	Margin [dB]
5180	-0.429	0.305	2.956	3.160	-0.203
5240	-0.686	0.177	2.767	3.160	-0.393
<p>Note: 1. The highest output power was observed at 6Mbps, 2 Data Streams. 2. The sum of Ch0 and Ch1 = Total PSD. 3. FCC Limit = 17 dBm – (6.84 dBi – 6 dBi) = 16.16 dBm. 4. RSS-247 Limit = 10 dBm – 6.84 dBi = 3.16 dBm. 5. Plots for all the measurements stated above were taken, to reduce complexity and bulkiness of the report Highlighted Plots are placed in the report.</p>					

Table 17: Peak Power Spectral Density – Test Results – Beamforming Continued

Test Conditions: Conducted Measurement, Normal Temperature and Voltage only					
Antenna Type: FPCB			Power Setting: See test plan		
Total Directional Gain: + 6.84 dBi					
Signal State: Modulated at 100%.					
Ambient Temp.: 22° C			Relative Humidity: 39%		
802.11n (FCC Limit)					
Freq. (MHz)	Ch0 [dBm]	Ch1 [dBm]	Total PSD [dBm]	Limit [dBm]	Margin [dB]
5180	11.860	12.760	15.332	16.160	-0.828
5240	12.471	13.696	16.115	16.160	-0.045
802.11n (RSS Limit)					
Freq. (MHz)	Ch0 [dBm]	Ch1 [dBm]	Total PSD [dBm]	Limit [dBm]	Margin [dB]
5180	-0.054	0.224	3.096	3.160	-0.063
5240	-0.645	-0.016	2.685	3.160	-0.474
<p>Note: 1.The highest output power was observed at HT20 MCS0, 2 Data Streams. 2. The sum of Ch0 and Ch1 = Total PSD. 3. FCC Limit = 17 dBm – (6.84 dBi – 6 dBi) = 16.16 dBm. 4. RSS-247 Limit = 10 dBm – 6.84 dBi = 3.16 dBm. 5. Plots for all the measurements stated above were taken, to reduce complexity and bulkiness of the report Highlighted Plots are placed in the report.</p>					

Table 18: Peak Power Spectral Density – Test Results – Beamforming Continued

Test Conditions: Conducted Measurement, Normal Temperature and Voltage only					
Antenna Type: FPCB			Power Setting: See test plan		
Total Directional Gain: + 6.84 dBi					
Signal State: Modulated at 100%.					
Ambient Temp.: 22° C			Relative Humidity: 39%		
Peak Power Spectral Density					
802.11n (FCC Limit)					
Freq. (MHz)	Ch0 [dBm]	Ch1 [dBm]	Total PSD [dBm]	Limit [dBm]	Margin [dB]
5190	6.714	5.402	9.093	16.160	-7.067
5230	12.063	13.144	15.631	16.160	-0.529
802.11n (RSS Limit)					
Freq. (MHz)	Ch0 [dBm]	Ch1 [dBm]	Total PSD [dBm]	Limit [dBm]	Margin [dB]
5190	-0.995	-0.118	2.465	3.160	-0.694
5230	-1.260	0.391	2.615	3.160	-0.544
<p>Note: 1. The highest output power was observed at HT40 MCS0, 2 Data Streams. 2. The sum of Ch0 and Ch1 = Total PSD. 3. FCC Limit = 17 dBm – (6.84 dBi – 6 dBi) = 16.16 dBm. 4. RSS-247 Limit = 10 dBm – 6.84 dBi = 3.16 dBm. 5. Plots for all the measurements stated above were taken, to reduce complexity and bulkiness of the report Highlighted Plots are placed in the report.</p>					

Table 19: Peak Power Spectral Density – Test Results – Beamforming Continued

Test Conditions: Conducted Measurement, Normal Temperature and Voltage only					
Antenna Type: FPCB			Power Setting: See test plan		
Total Directional Gain: + 6.84 dBi					
Signal State: Modulated at 100%.					
Ambient Temp.: 22° C			Relative Humidity: 39%		
802.11ac (FCC Limit)					
Freq. (MHz)	Ch0 [dBm]	Ch1 [dBm]	Total PSD [dBm]	Limit [dBm]	Margin [dB]
5190	5.438	5.855	8.659	16.160	-7.501
5230	11.813	13.527	15.723	16.160	-0.437
802.11ac (RSS Limit)					
Freq. (MHz)	Ch0 [dBm]	Ch1 [dBm]	Total PSD [dBm]	Limit [dBm]	Margin [dB]
5190	-0.777	-0.114	2.571	3.160	-0.588
5230	-1.342	0.179	2.462	3.160	-0.697
Note: The highest output power was observed at VHT40 MCS0, 1 Data Stream.					
802.11ac (FCC Limit)					
Freq. (MHz)	Ch0 [dBm]	Ch1 [dBm]	Total PSD [dBm]	Limit [dBm]	Margin [dB]
5210	-0.913	1.705	3.505	16.160	-12.655
802.11ac (RSS Limit)					
Freq. (MHz)	Ch0 [dBm]	Ch1 [dBm]	Total PSD [dBm]	Limit [dBm]	Margin [dB]
5210	-4.865	-3.506	-2.98	3.160	-4.308
Note: 1. The highest output power was observed at VHT80 MCS0, 2 Data Streams. 2. The sum of Ch0 and Ch1 = Total PSD. 3. FCC Limit = 17 dBm – (6.84 dBi – 6 dBi) = 16.16 dBm. 4. RSS-247 Limit = 10 dBm – 6.84 dBi = 3.16 dBm. 5. Plots for all the measurements stated above were taken, to reduce complexity and bulkiness of the report Highlighted Plots are placed in the report.					

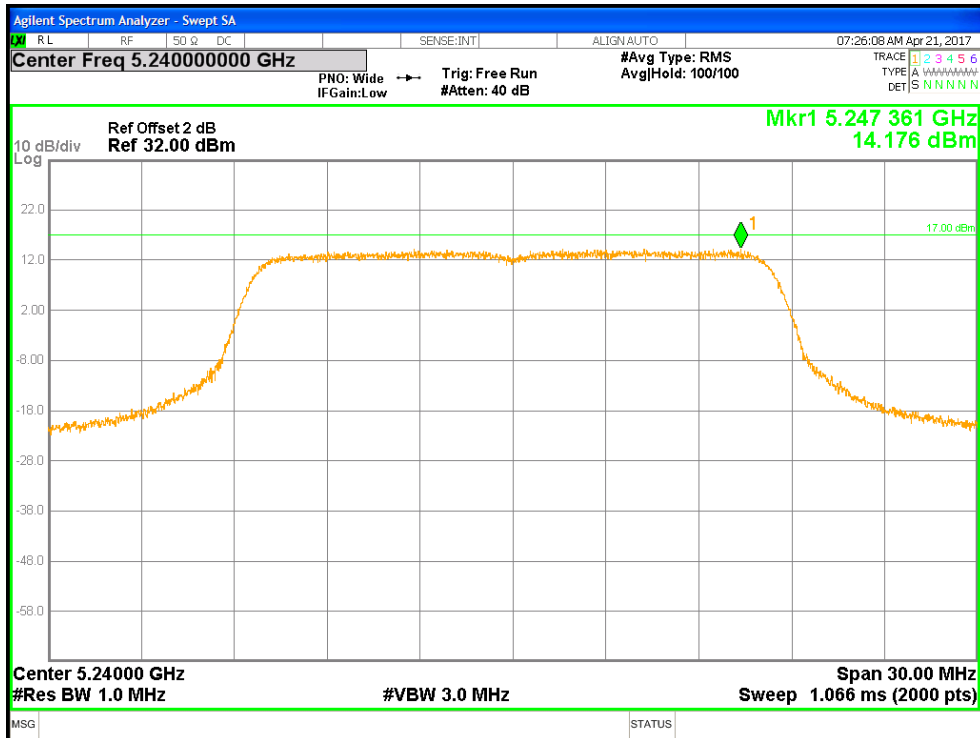

Figure 26: Non-Beamforming Power Spectral Density (FCC), 5240 MHz at 802.11a, Chain 1

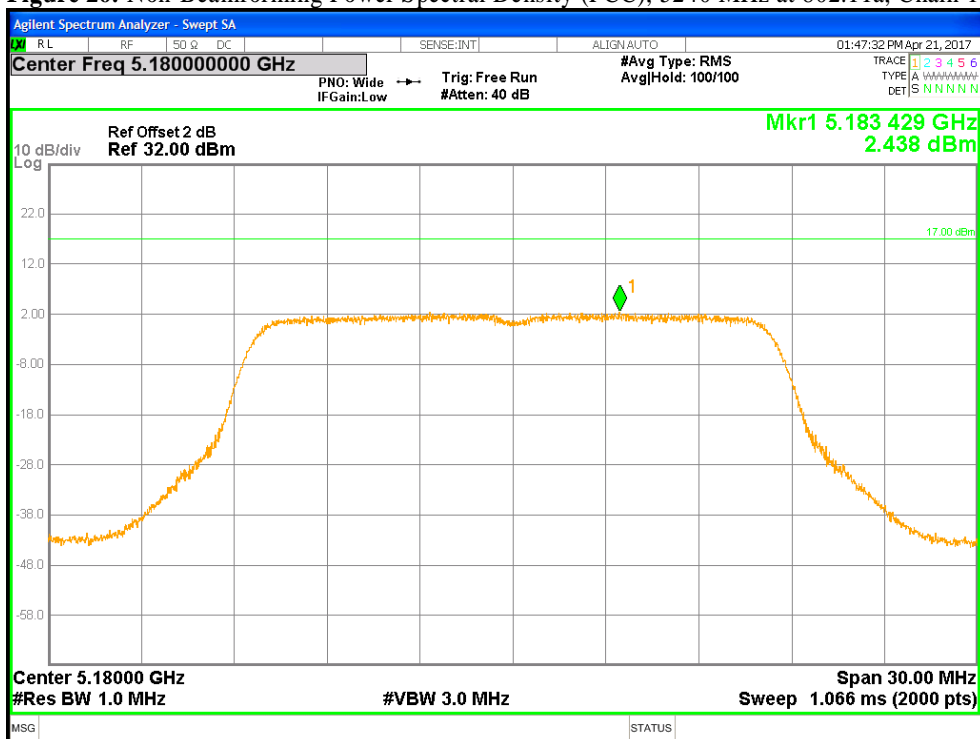

Figure 27: Non-Beamforming Power Spectral Density (RSS), 5180 MHz at 802.11a, Chain 1

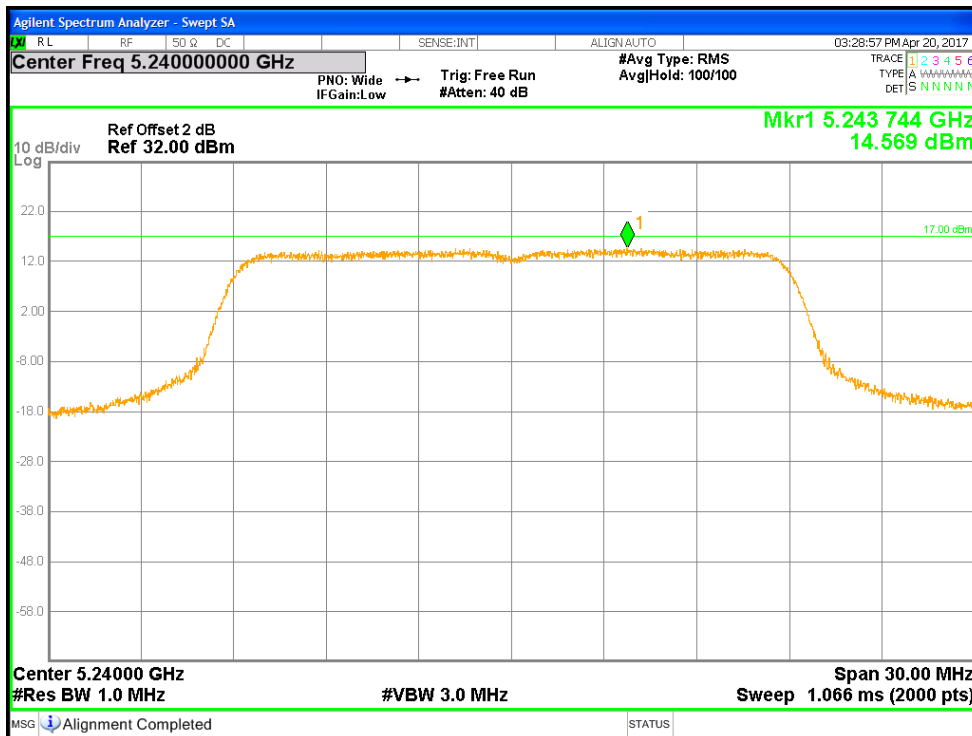

Figure 28: Non-Beamforming Power Spectral Density (FCC), 5240 MHz at HT20, Chain 1

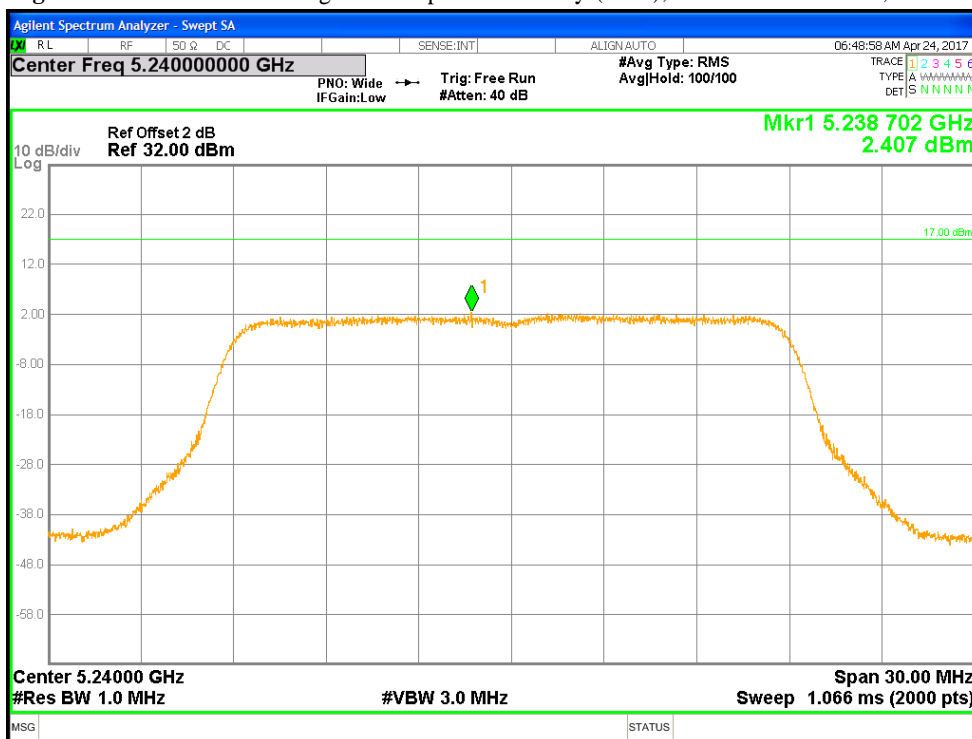

Figure 29: Non-Beamforming Power Spectral Density (RSS), 5240 MHz at HT20, Chain 1

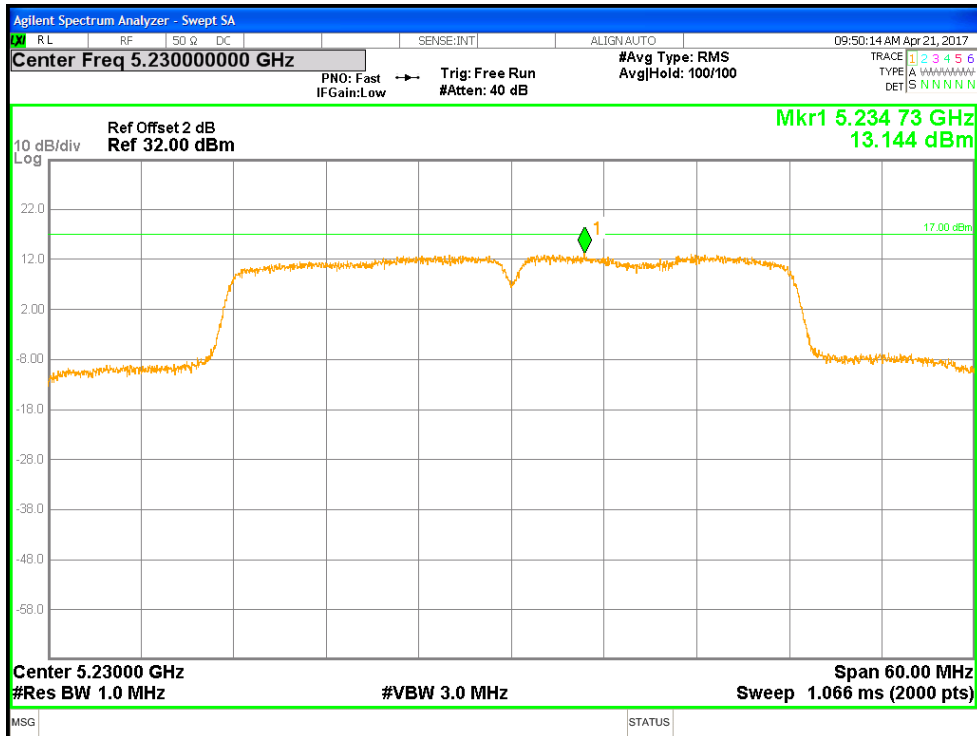

Figure 30: Non-Beamforming Power Spectral Density (FCC), 5230 MHz at HT40, Chain 1

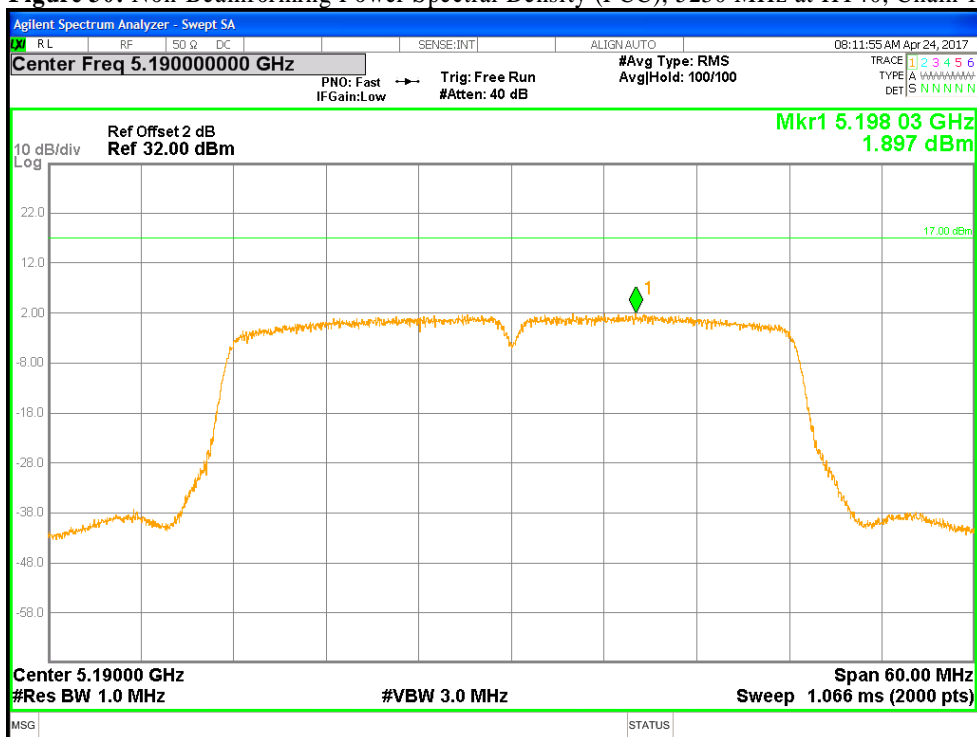

Figure 31: Non-Beamforming Power Spectral Density (RSS), 5190 MHz at HT40, Chain 1

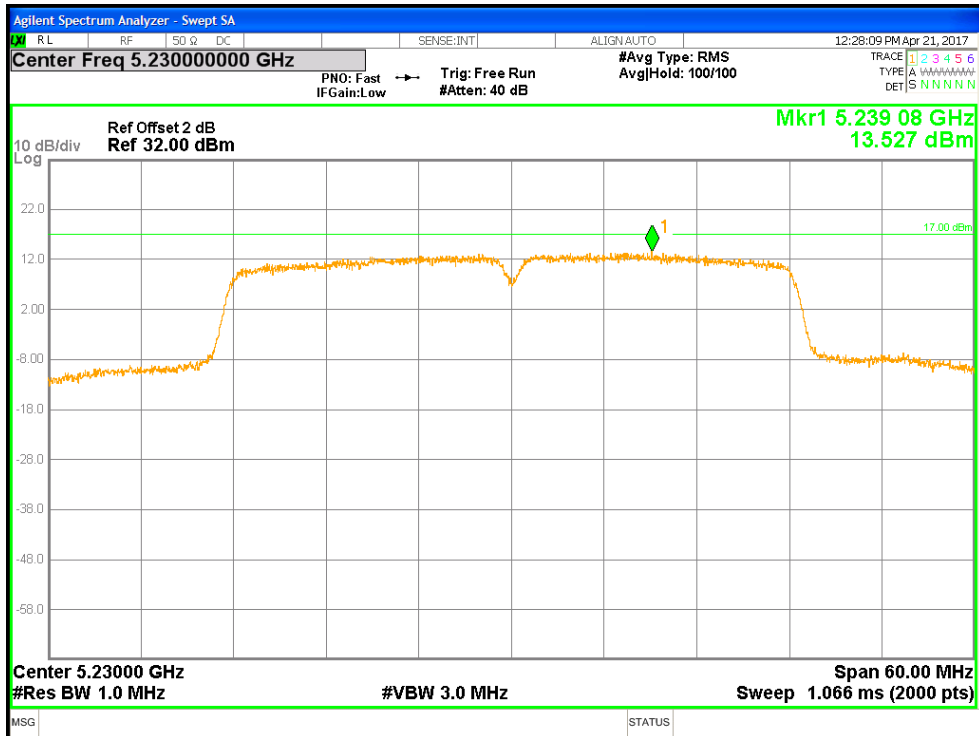

Figure 32: Non-Beamforming Power Spectral Density (FCC), 5230 MHz at VHT40, Chain 1

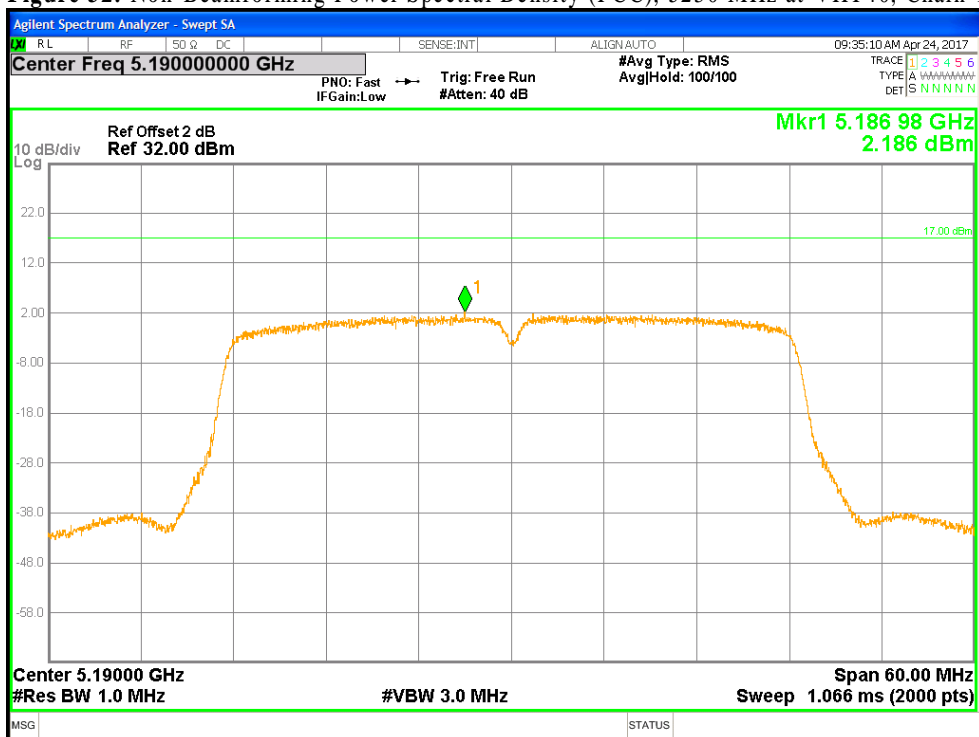

Figure 33: Non-Beamforming Power Spectral Density (RSS), 5190 MHz at VHT40, Chain 1

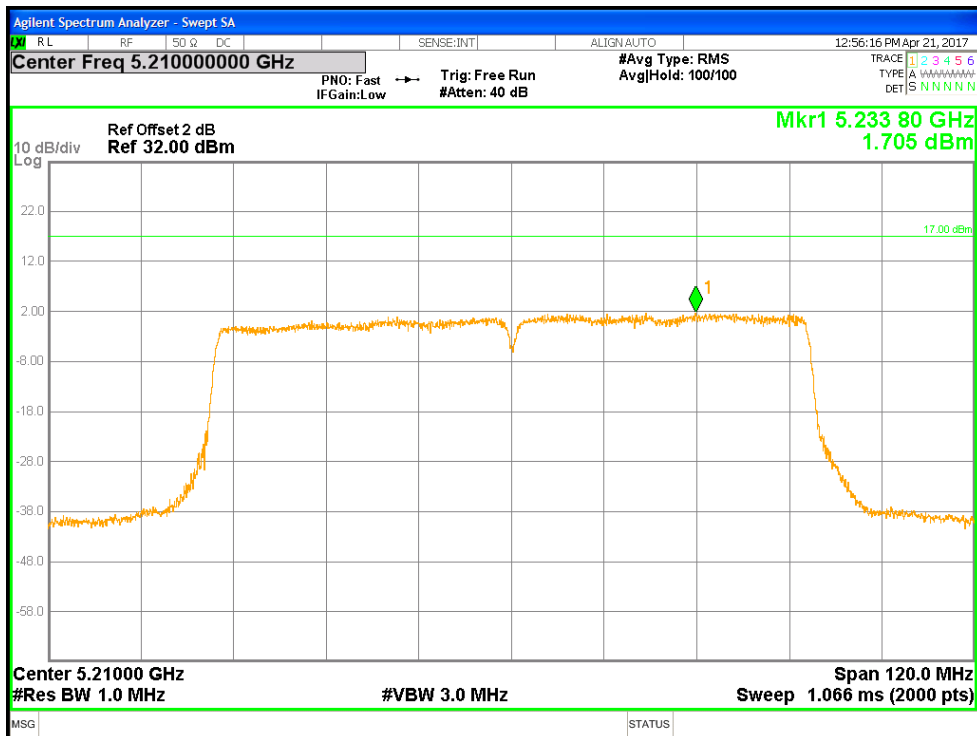

Figure 34: Non Beamforming Power Spectral Density (FCC), 5210 MHz at VHT80, Chain 1

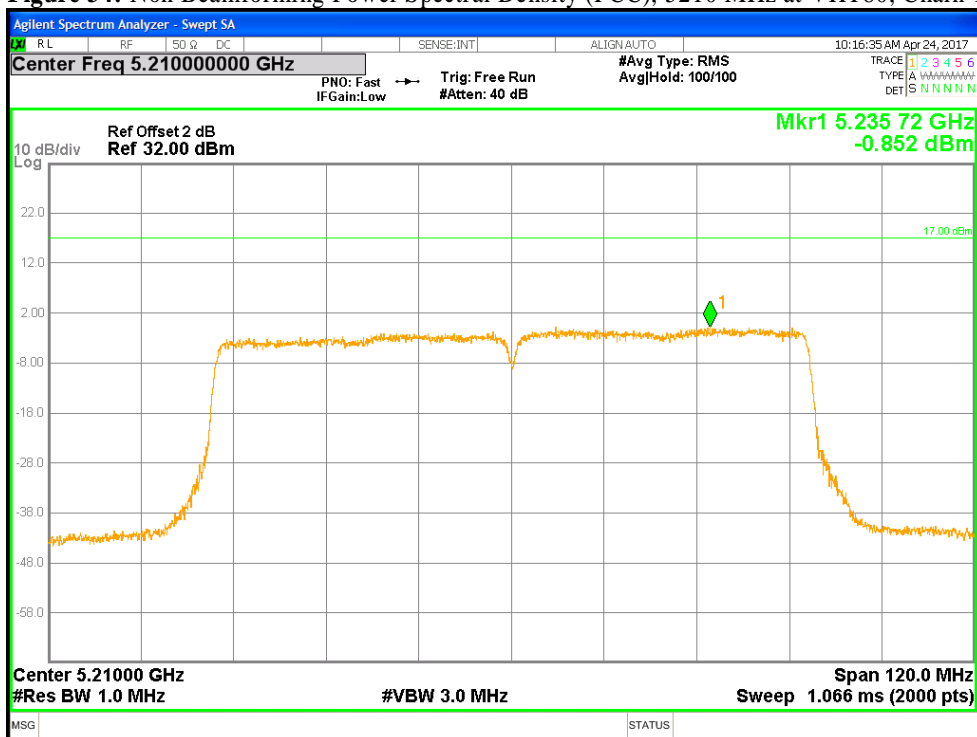

Figure 35: Non Beamforming Power Spectral Density (RSS), 5210 MHz at VHT80, Chain 1

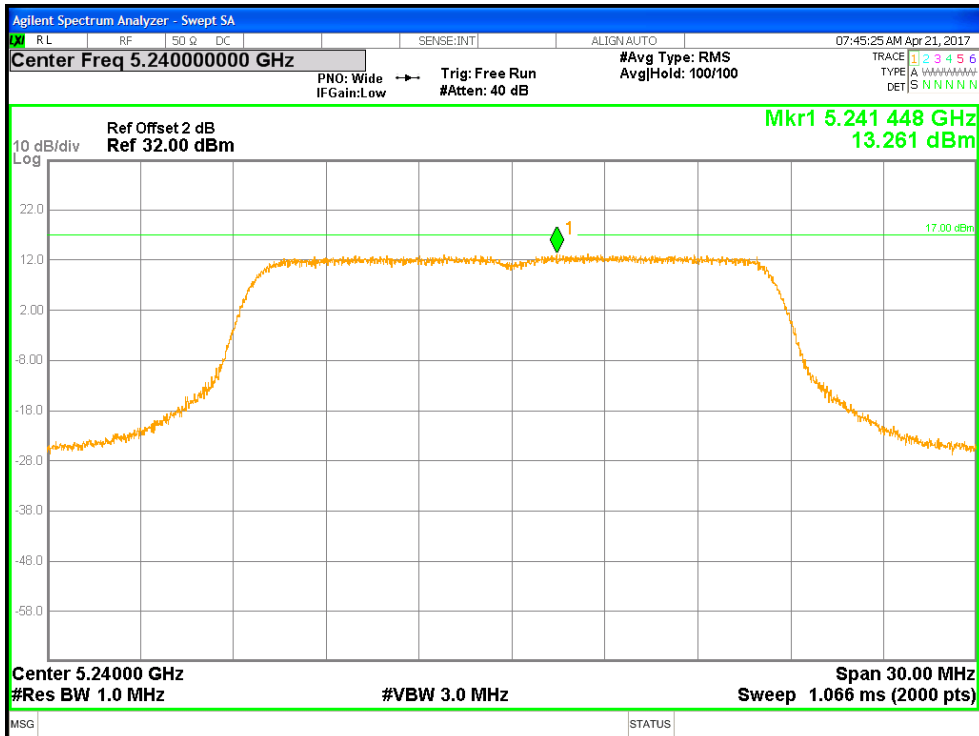

Figure 36: Beamforming Power Spectral Density (FCC), 5240 MHz at 802.11a, Chain 1

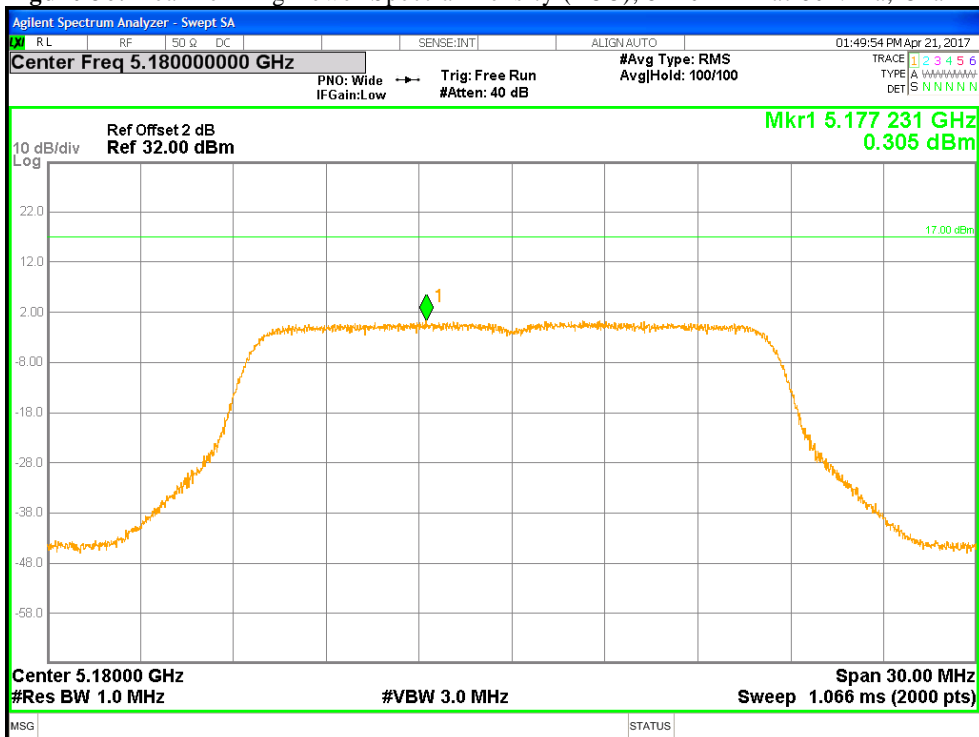

Figure 37: Beamforming Power Spectral Density (RSS), 5180 MHz at 802.11a, Chain 1

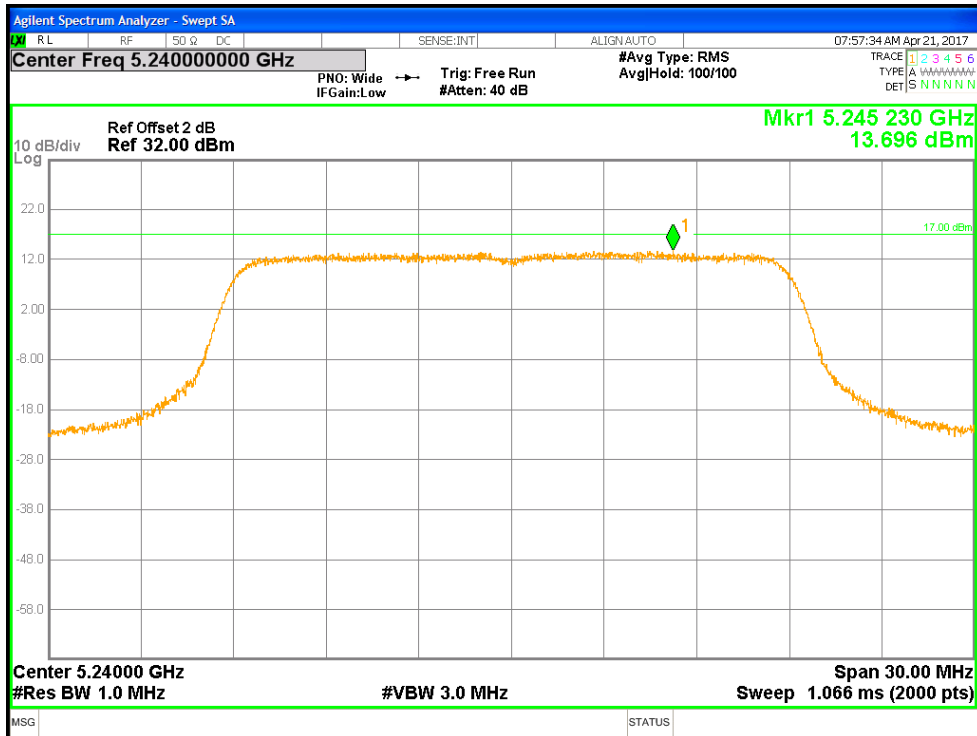

Figure 38: Beamforming Power Spectral Density (FCC), 5240 MHz at HT20, Chain 1

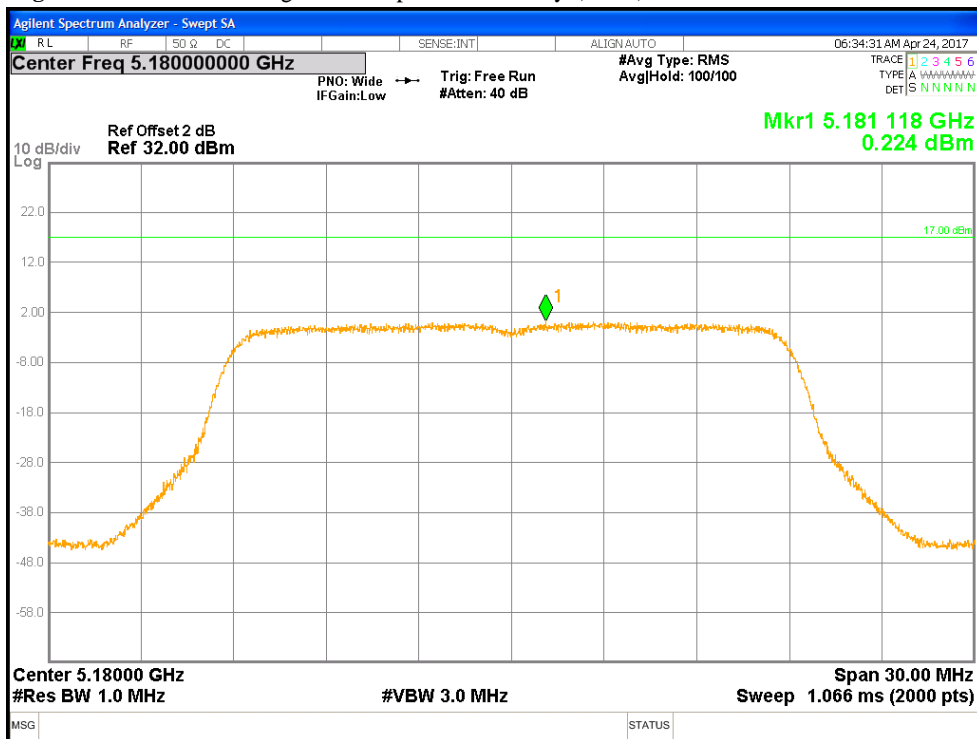

Figure 39: Beamforming Power Spectral Density (RSS), 5180 MHz at HT20, Chain 1

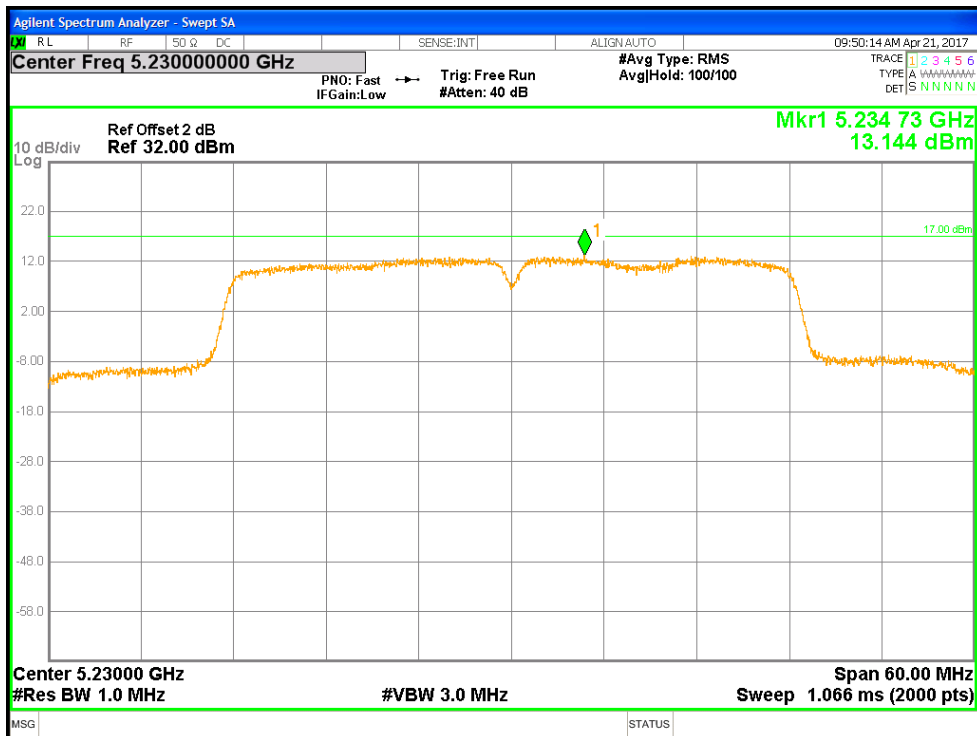

Figure 40: Beamforming Power Spectral Density (FCC), 5230 MHz at HT40, Chain 1

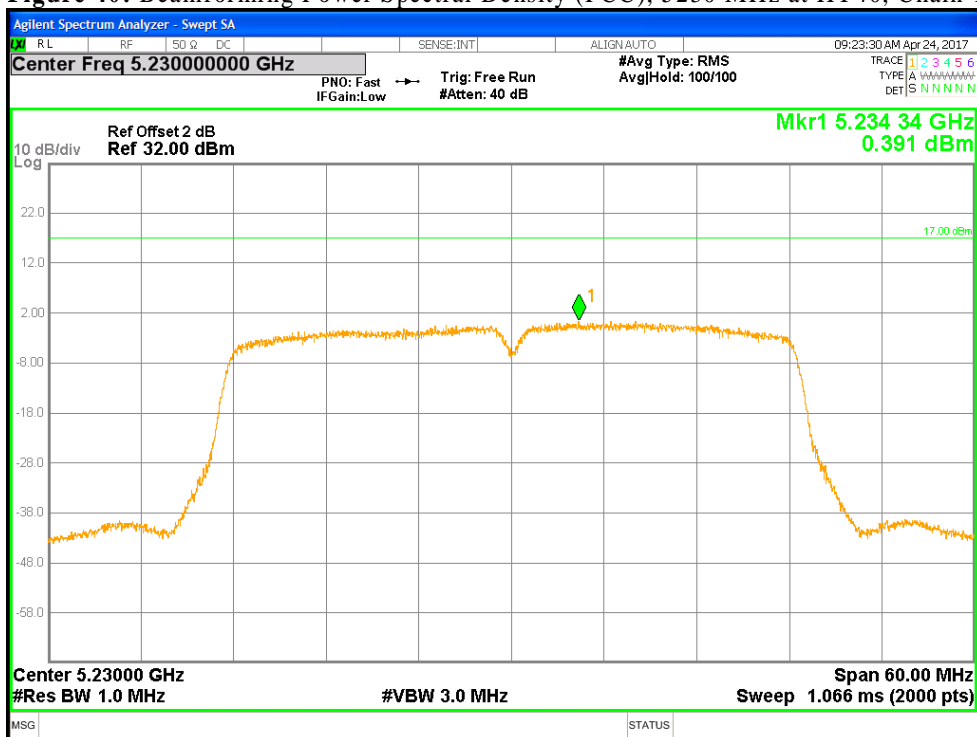

Figure 41: Beamforming Power Spectral Density (RSS), 5230 MHz at HT40, Chain 1

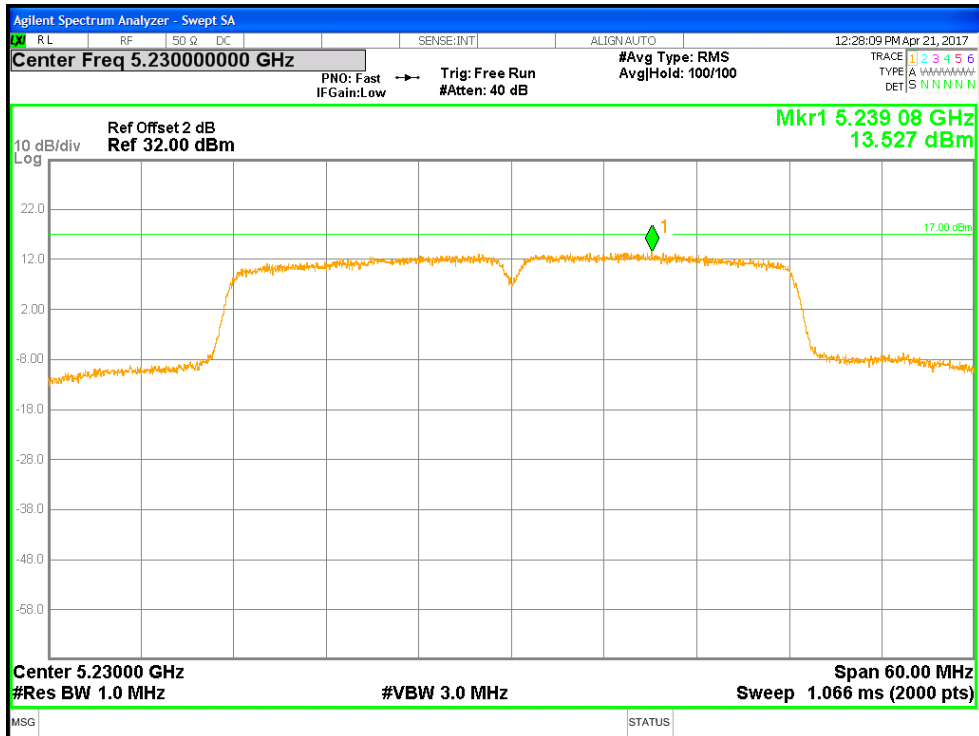

Figure 42: Beamforming Power Spectral Density (FCC), 5230 MHz at VHT40, Chain 1

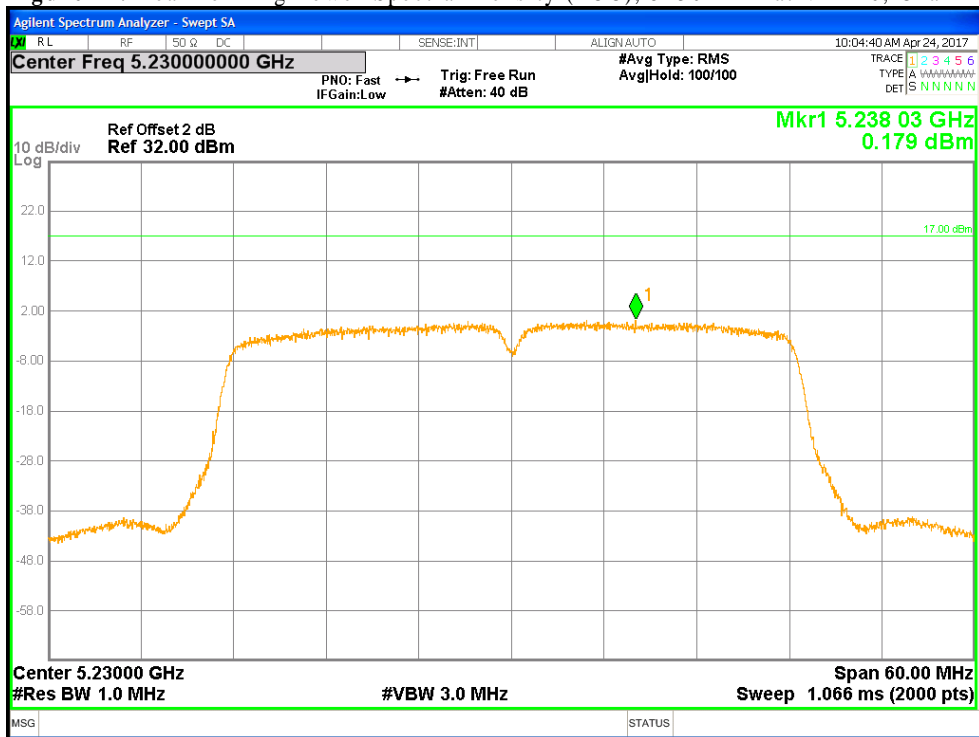

Figure 43: Beamforming Power Spectral Density (RSS), 5230 MHz at VHT40, Chain 1

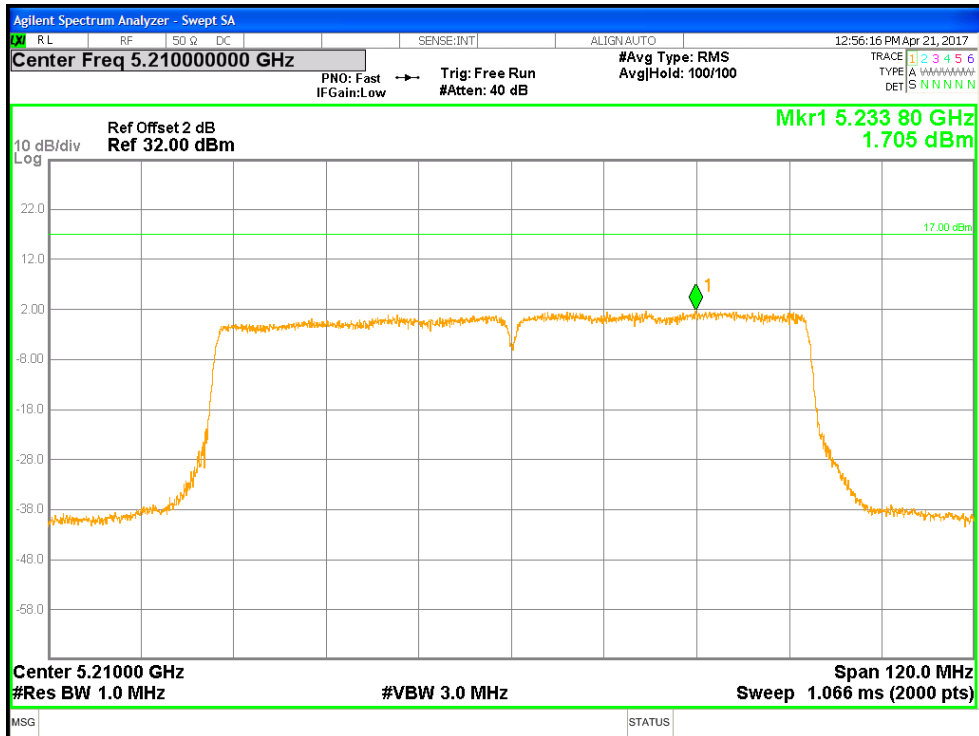

Figure 44: Beamforming Power Spectral Density (FCC), 5210 MHz at VHT80, Chain 1

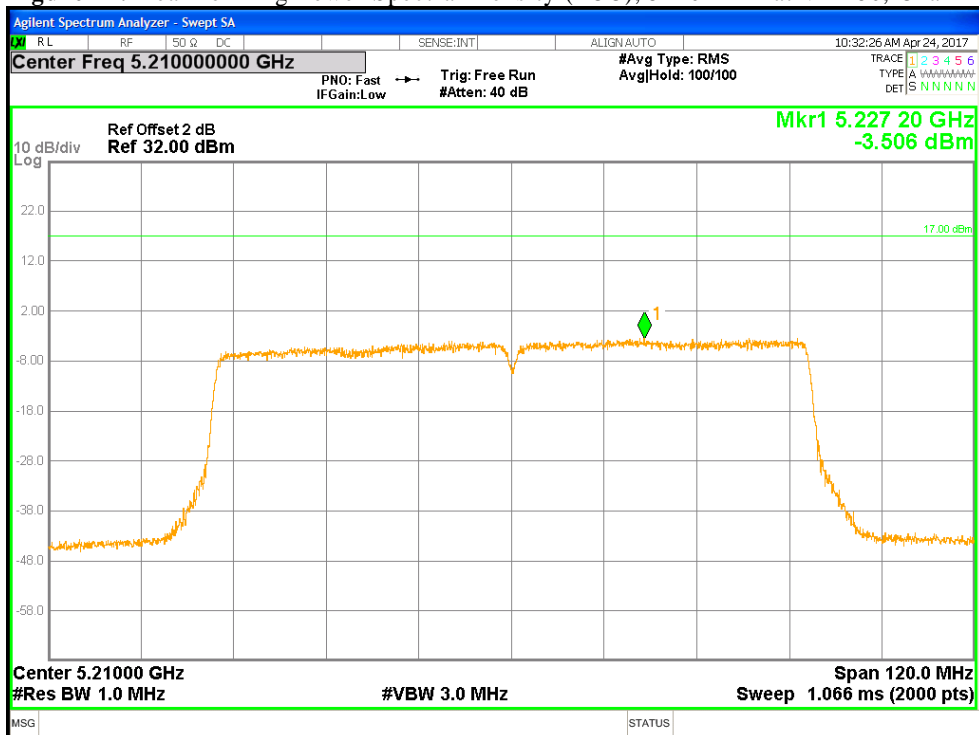

Figure 45: Beamforming Power Spectral Density (RSS), 5210 MHz at VHT80, Chain 1

4.4 Undesirable Emission Limits

CFR47 15.407 (b) and RSS 247 Sect.6.2.1.2: The maximum emissions outside of the frequency bands of operation shall be attenuated in accordance with the following limits:

For transmitters operating in the 5.15-5.25 GHz band: All emissions outside of the 5.15-5.35 GHz band shall not exceed an e.i.r.p. of -27 dBm/MHz.

4.4.1 Test Method

The conducted method was used to measure the undesirable emission requirement. The measurement was performed with modulation. This test was conducted on 3 channels of Sample in each mode on Sample. The worst sample result indicated below.

Test Setup:

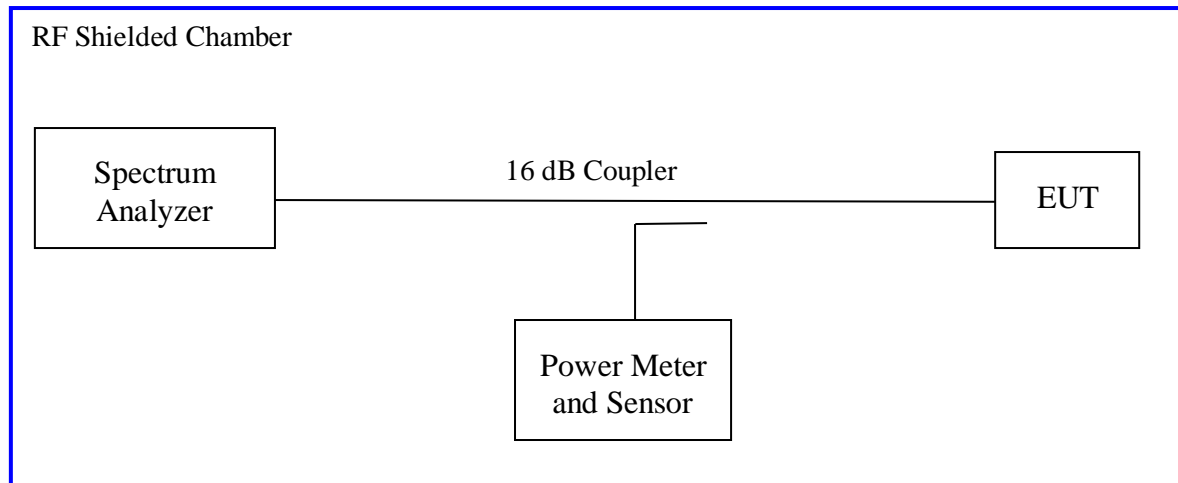

Measurement Procedure AVG2 of KDB 662911

4.4.2 Results

As originally tested, the EUT was found to be compliant to the requirements of the test standard(s).

Verification of transmit duty cycle. The duty cycle (%) = (ON time / Period) * 100%
 Therefore, 98.8% = (5.002 / 5.064) * 100

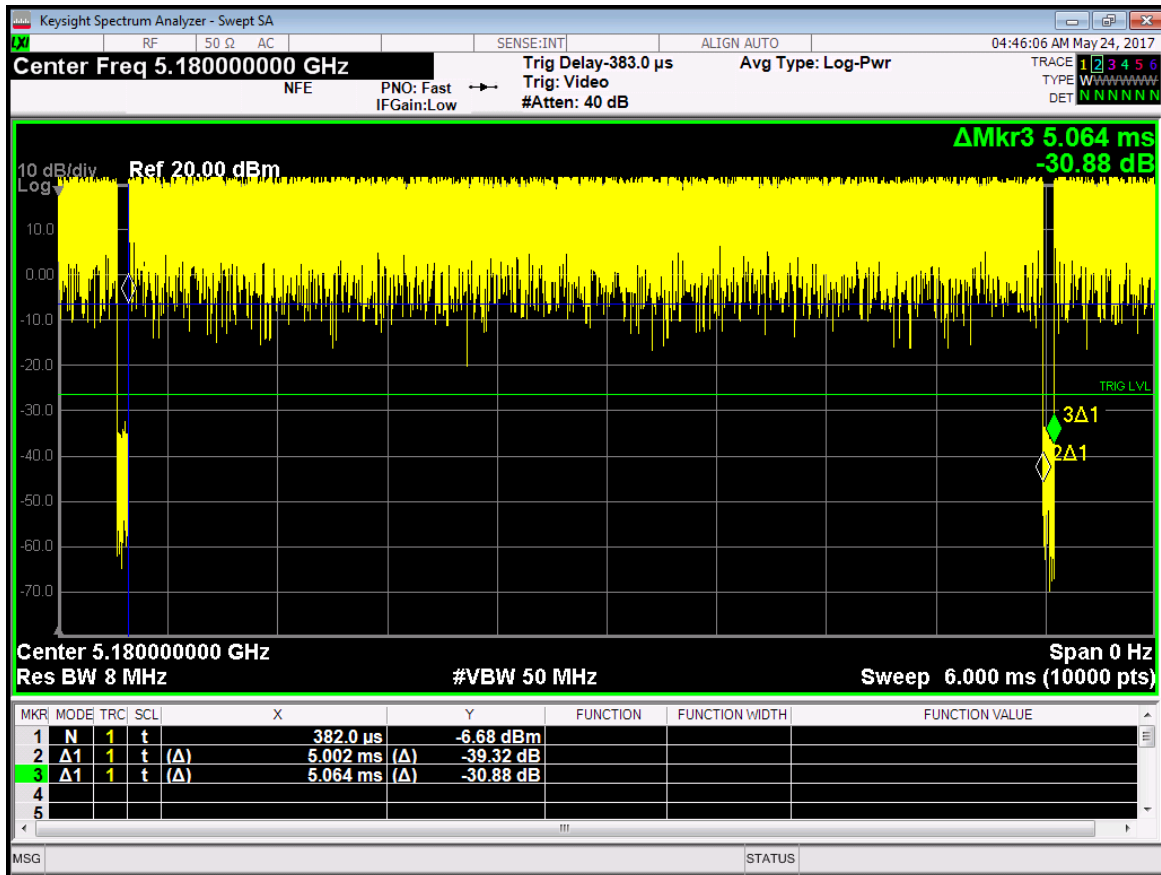

Figure 46: Transmit Duty Cycle

Table 20: Emissions at the Band-Edge – Test Results

Test Conditions: Conducted Measurement, Normal Temperature and Voltage only						
Antenna Type: FPCB			Power Setting: See test plan			
Max. Directional Gain: Antenna 1 = + 3.01 dBi; Antenna 3 = + 4.58 dBi						
Total Directional Gain: + 6.84 dBi						
Signal State: Modulated at 100%.						
Ambient Temp.: 22° C			Relative Humidity: 39%			
Non-Restricted Frequency Band Emission						
Freq. (MHz)	Mode	Chain	Measured (dBm)	Limit (dBm)	Plots	Comments
5149.43	6Mbps	0	-32.40	-27.00	Fig. 47, 48	Pass TX at 5180 MHz; TP23.5
5148.40	6Mbps	1	-27.90	-27.00	Fig. 49, 50	Pass TX at 5180 MHz; TP23.5
5150.00	6Mbps	0	-42.50	-27.00	*	Pass TX at 5240 MHz; TP25
5150.00	6Mbps	1	-42.56	-27.00	*	Pass TX at 5240 MHz; TP25
5248.29	6Mbps	0	N/A	N/A	Fig. 51	Pass In-band-edge. No DFS needed.
5248.28	6Mbps	1	N/A	N/A	Fig. 52	Pass In-band-edge. No DFS needed.
5149.27	HT20-MCS0	0	-32.91	-27.00	Fig. 53, 54	Pass TX at 5180 MHz; TP24
5149.39	HT20-MCS0	1	-32.58	-27.00	Fig. 55, 56	Pass TX at 5180 MHz; TP24
5350.00	HT20-MCS0	0	-42.55	-27.00	*	Pass TX at 5200 MHz; TP26
5350.00	HT20-MCS0	1	-41.88	-27.00	*	Pass TX at 5200 MHz; TP26
5248.88	HT20-MCS0	0	N/A	N/A	Fig. 57	Pass In-band-edge. No DFS needed.
5249.00	HT20-MCS0	1	N/A	N/A	Fig. 58	Pass In-band-edge. No DFS needed.
5150.00	HT40 MCS0	0	-33.44	-27.00	Fig. 59, 60	Pass TX at 5190 MHz; TP20.5
5148.32	HT40 MCS0	1	-29.01	-27.00	Fig. 61, 62	Pass TX at 5190 MHz; TP20.5
<p>Note: 1. All out of band emissions are lower than the 27dBr level.</p> <p>2. The maximum out of band emission on each individual output is at least 27 dB below the maximum in-band PSD on that output per KDB 662911.</p> <p>3. Plots for all the measurements stated above were taken. To reduce complexity and bulkiness of the report, (*) plots were not placed in the report due to margin from the limit.</p>						

Table 21: Emissions at the Band-Edge – Test Results Continued

Test Conditions: Conducted Measurement, Normal Temperature and Voltage only						
Antenna Type: FPCB			Power Setting: See test plan			
Max. Directional Gain: Antenna 1 = + 3.01 dBi; Antenna 3 = + 4.58 dBi						
Total Directional Gain: + 6.84 dBi						
Signal State: Modulated at 100%.						
Ambient Temp.: 22° C			Relative Humidity: 39%			
Non-Restricted Frequency Band Emission						
Freq. (MHz)	Mode	Chain	Measured (dBm)	Limit (dBm)	Plots	Comments
5248.25	HT40 MCS0	0	N/A	N/A	Fig. 63	Pass In-band-edge. No DFS needed.
5248.75	HT40 MCS0	1	N/A	N/A	Fig. 64	Pass In-band-edge. No DFS needed.
5149.70	VHT40 MCS0	0	-30.87	-27.00	Fig. 65, 66	Pass TX at 5190 MHz; TP20.5
5149.85	VHT40 MCS0	1	-30.12	-27.00	Fig. 67, 68	Pass TX at 5190 MHz; TP20.5
5248.11	VHT40 MCS0	0	N/A	N/A	Fig. 69	Pass In-band-edge. No DFS needed.
5248.52	VHT40 MCS0	1	N/A	N/A	Fig. 70	Pass In-band-edge. No DFS needed.
5150.00	VHT80 MCS0	0	-33.60	-27.00	Fig. 71, 72	Pass TX at 5210 MHz; TP19
5150.00	VHT80 MCS0	1	-33.51	-27.00	Fig. 73, 74	Pass TX at 5210 MHz; TP19
5248.25	VHT80 MCS0	0	N/A	N/A	Fig. 75	Pass In-band-edge. No DFS needed.
5248.25	VHT80 MCS0	1	N/A	N/A	Fig. 76	Pass In-band-edge. No DFS needed.
Note: 1. All out of band emissions are lower than the 27dBr level. 2. The maximum out of band emission on each individual output is at least 27 dB below the maximum in-band PSD on that output per KDB 662911.						

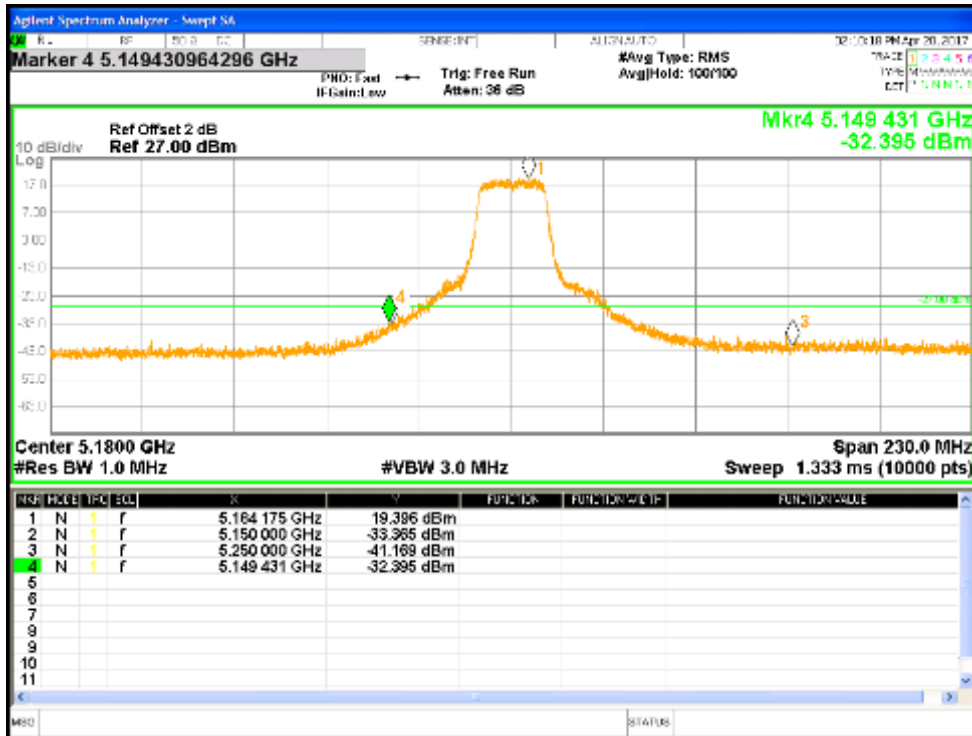

Figure 47: Measured Bandedge for 802.11a-6Mbps at 5180 MHz, Chain 0

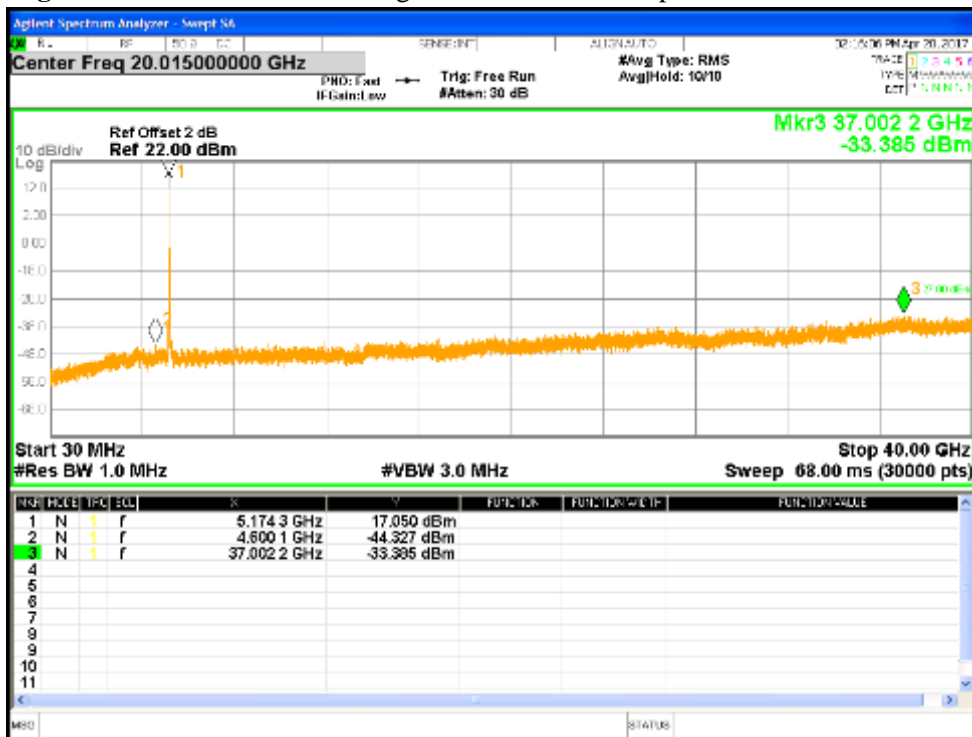

Figure 48: Undesirable Emission for 802.11a-6Mbps at 5180 MHz, Chain 0

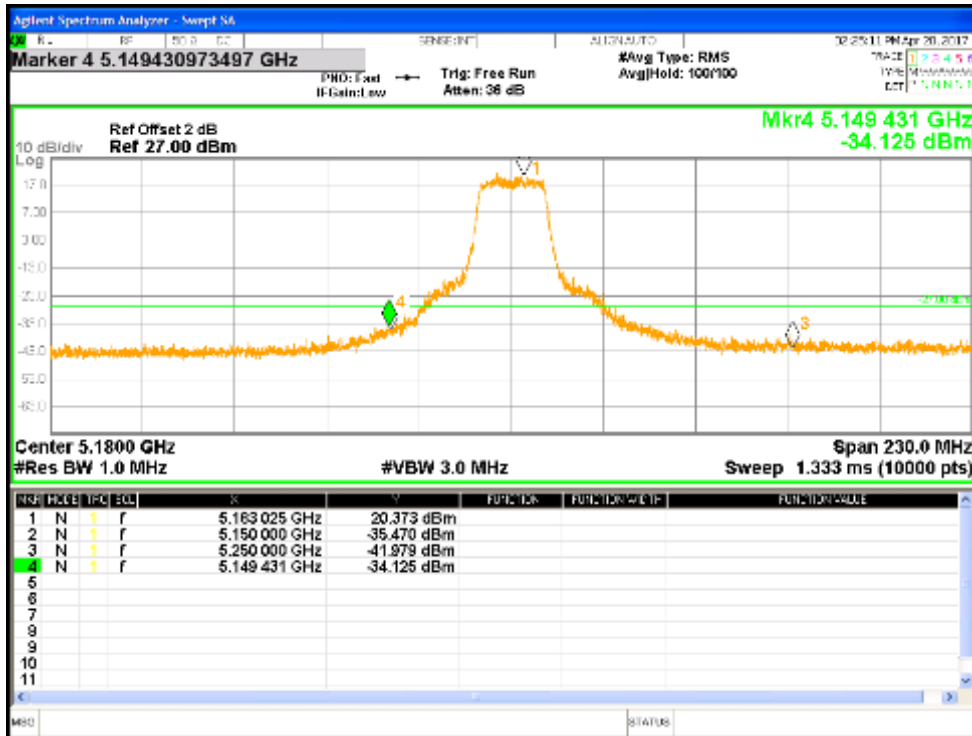

Figure 49: Measured Bandedge for 802.11a-6Mbps at 5180 MHz, Chain 1

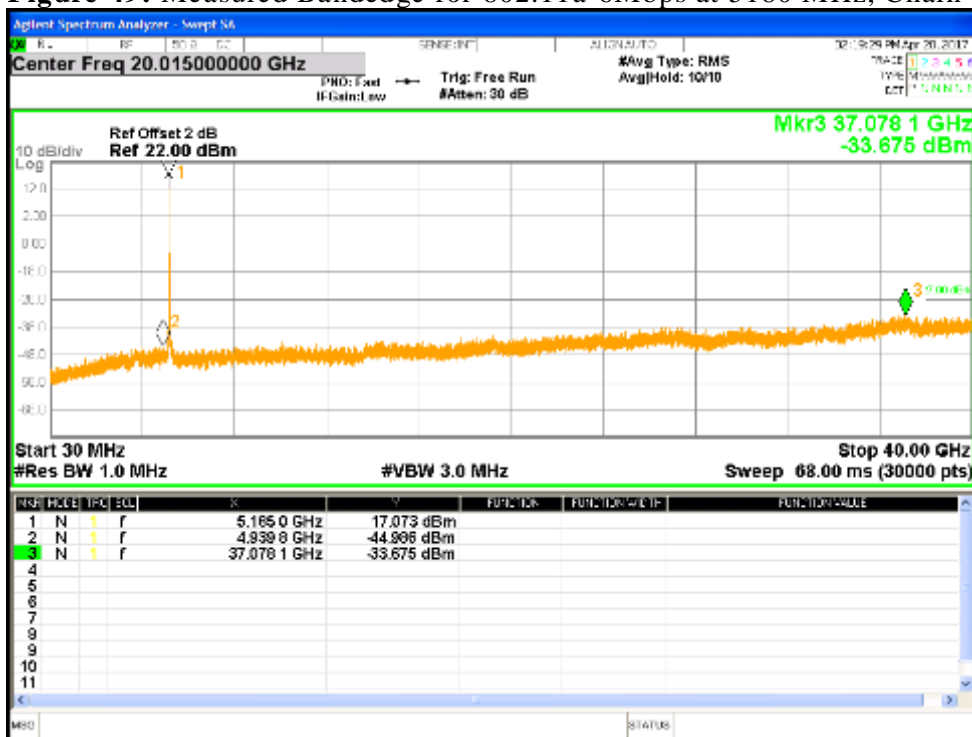

Figure 50: Undesirable Emission for 802.11a-6Mbps at 5180 MHz, Chain 1

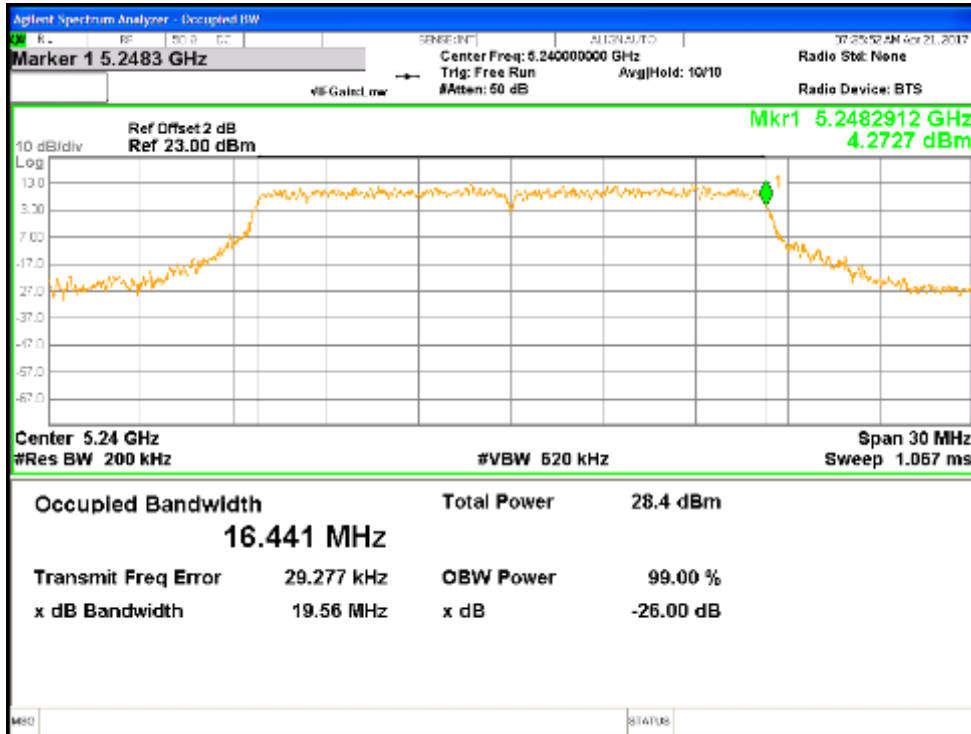

Figure 51: Measured In-Band edge for 802.11a-6Mbps at 5240 MHz, Chain 0

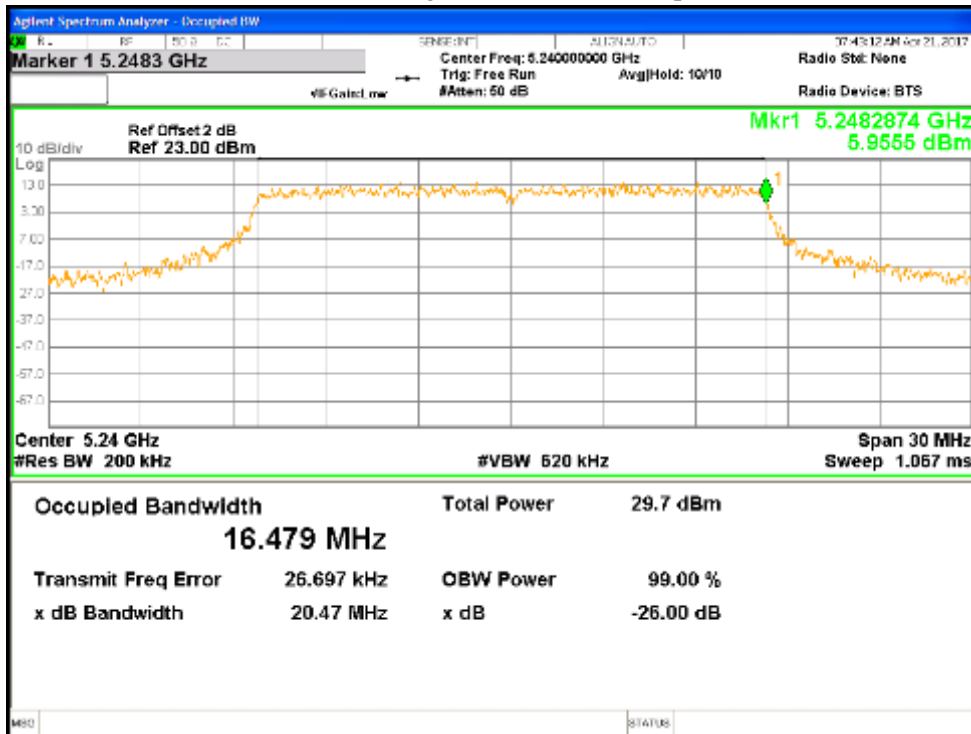

Figure 52: Measured In-Band edge for 802.11a-6Mbps at 5240 MHz, Chain 1

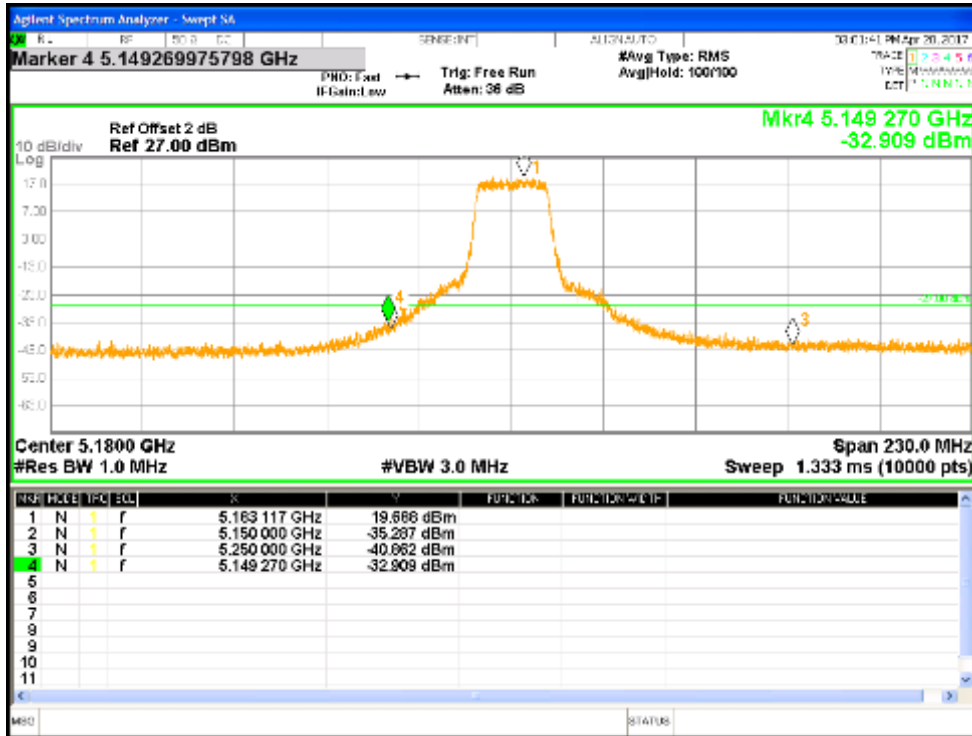

Figure 53: Measured Bandedge for HT20-MCS0 at 5180 MHz, Chain 0

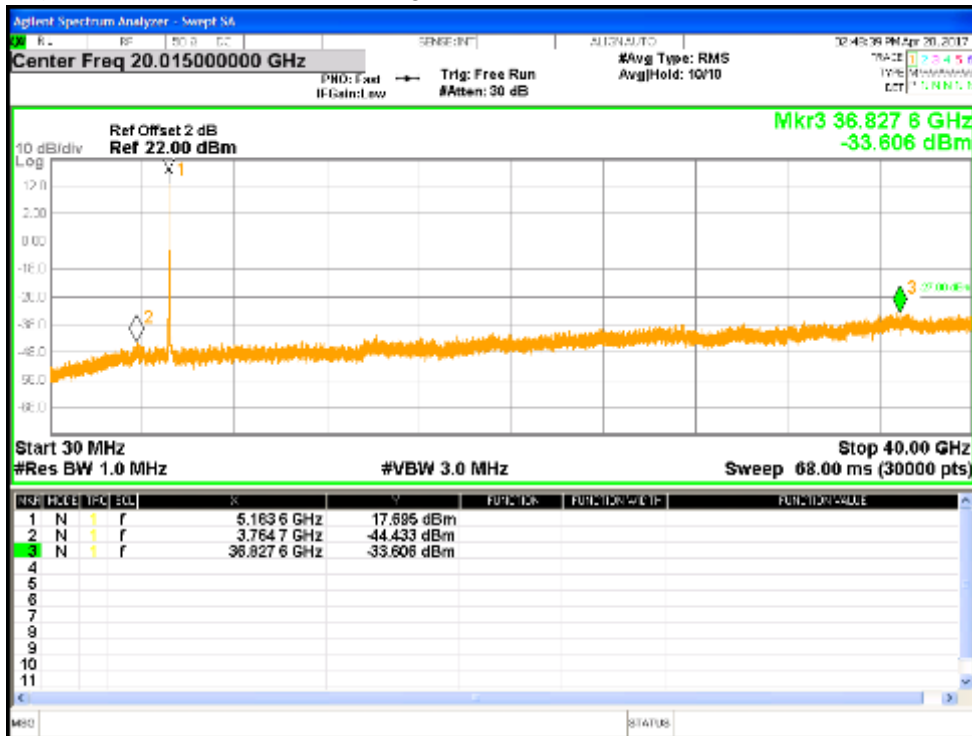

Figure 54: Undesirable Emission for HT20-MCS0 at 5180 MHz, Chain 0

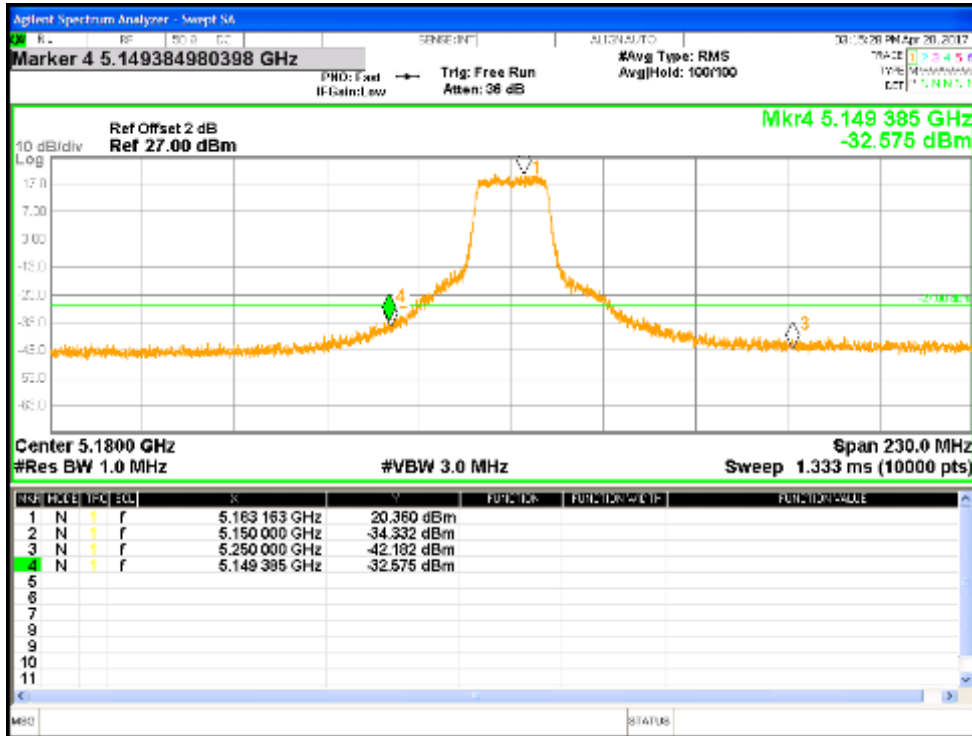

Figure 55: Measured Bandedge for HT20-MCS0 at 5180 MHz, Chain 1

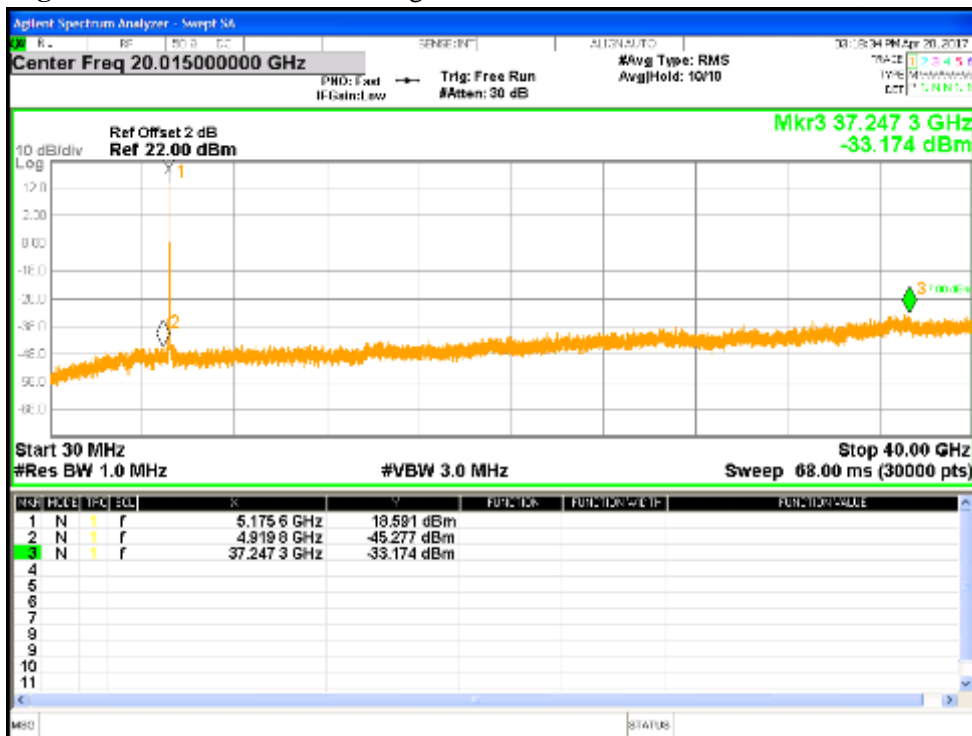

Figure 56: Undesirable Emission for HT20-MCS0 at 5180 MHz, Chain 1

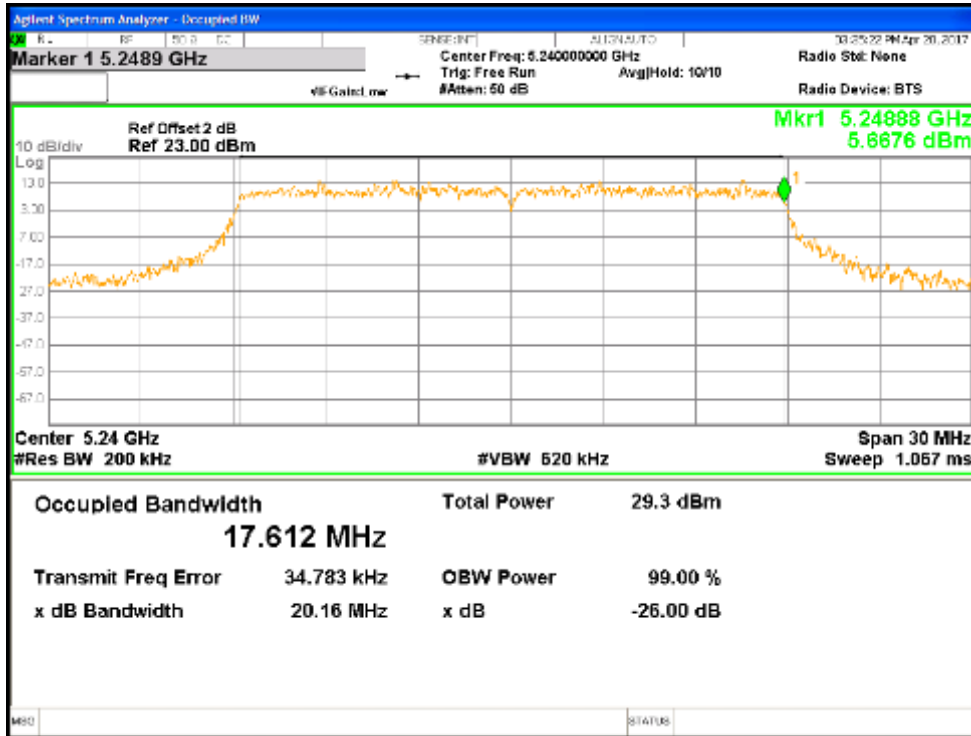

Figure 57: Measured In-Band edge for HT20-MCS0 at 5240 MHz, Chain 0

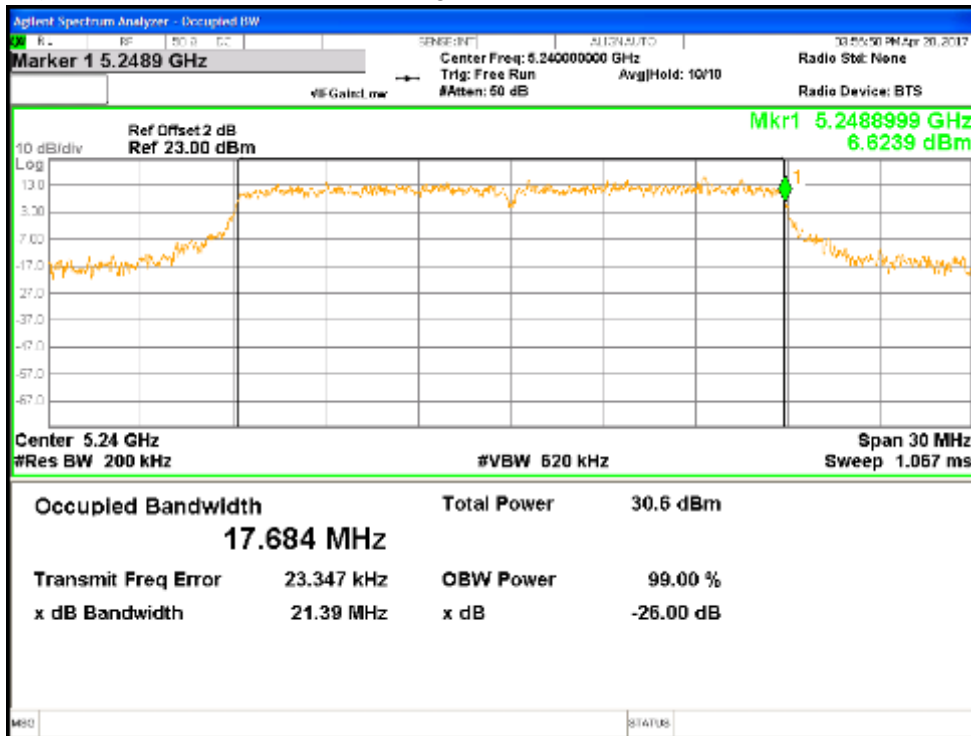

Figure 58: Measured In-Band edge for HT20-MCS0 at 5240 MHz, Chain 1

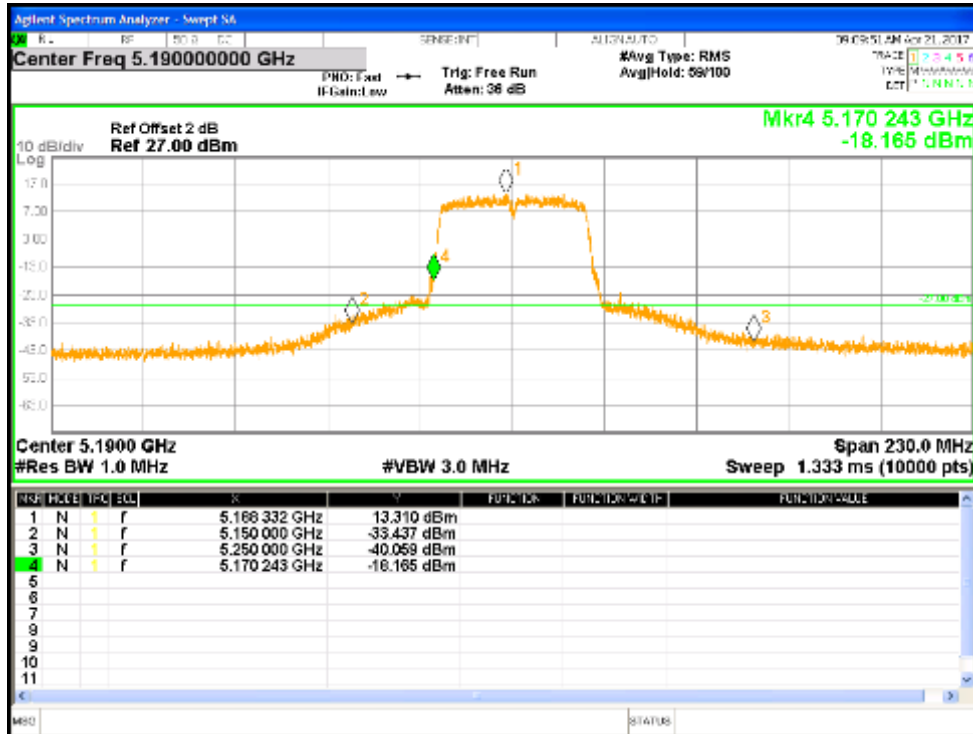

Figure 59: Measured Bandedge for HT40-MCS0 at 5190 MHz, Chain 0

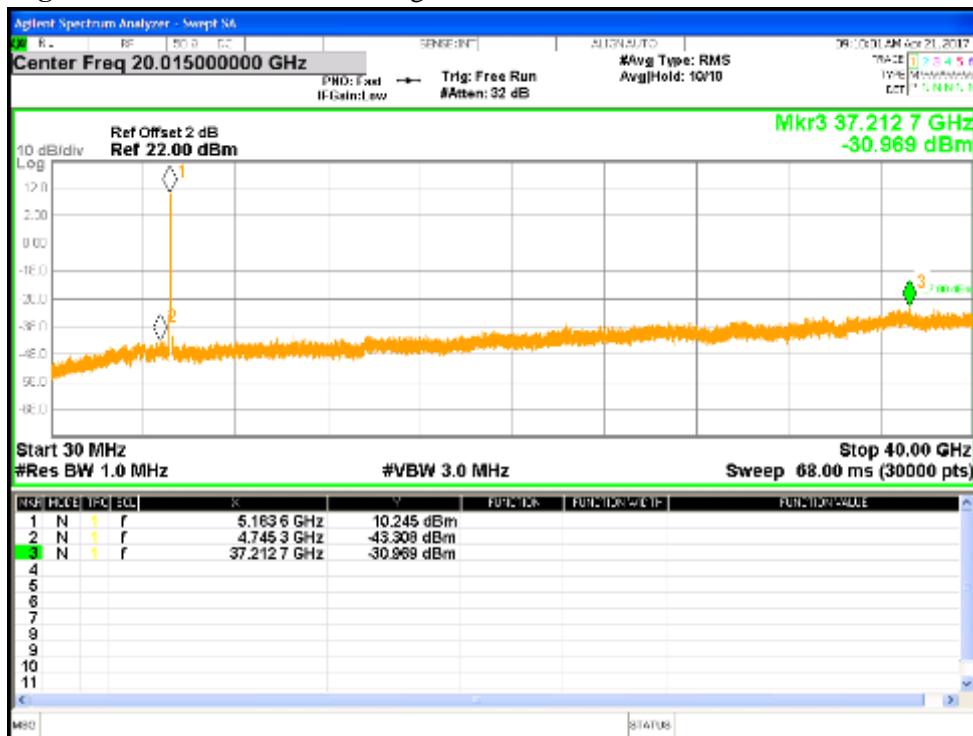

Figure 60: Undesirable Emission for HT40-MCS0 at 5190 MHz, Chain 0

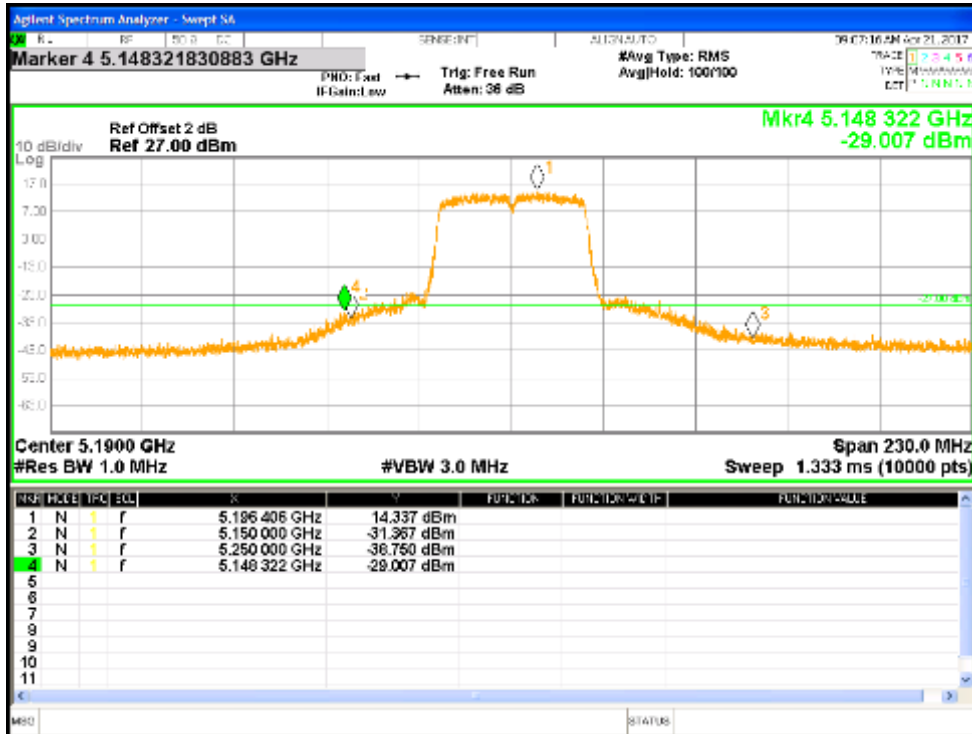

Figure 61: Measured Bandedge for HT40-MCS0 at 5190 MHz, Chain 1

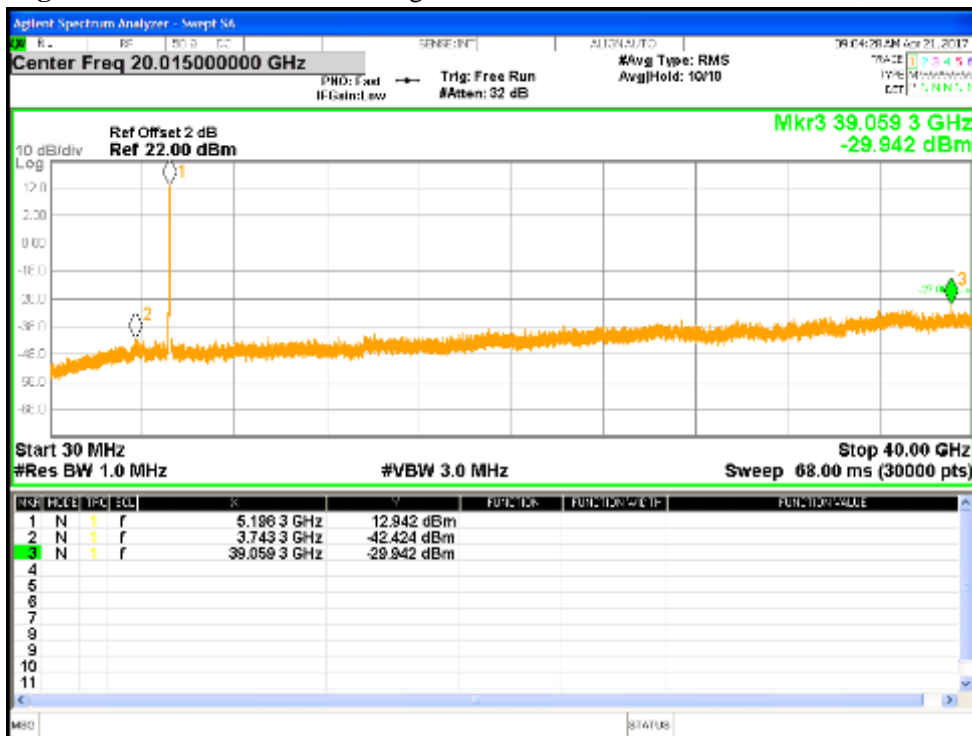

Figure 62: Undesirable Emission for HT40-MCS0 at 5190 MHz, Chain 1

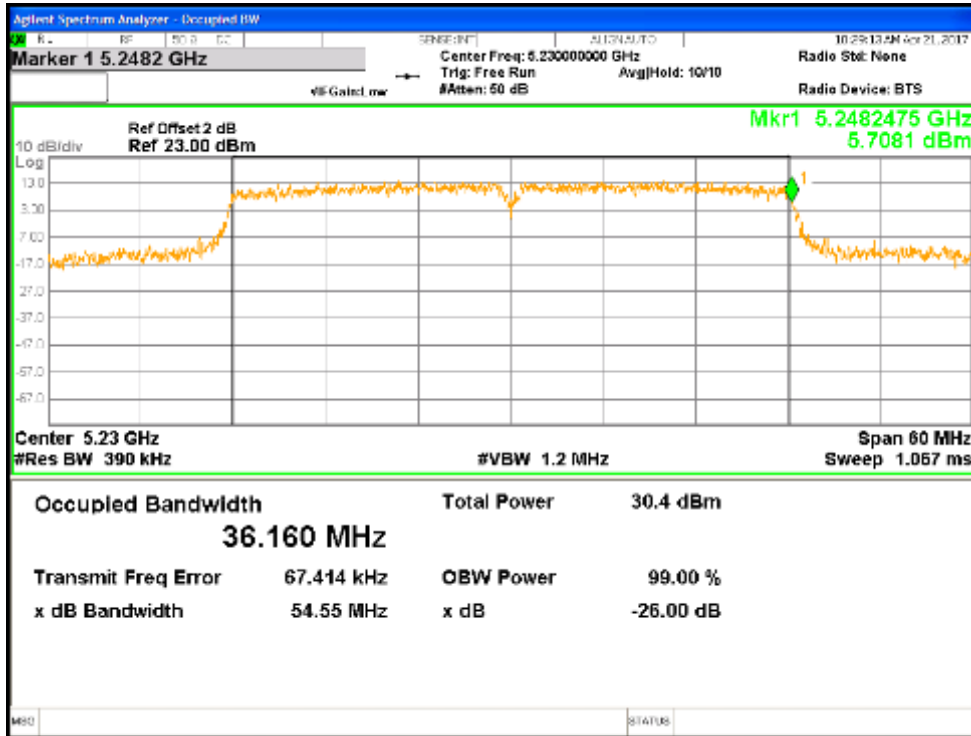

Figure 63: Measured In-Band edge for HT40-MCS0 at 5240 MHz, Chain 0

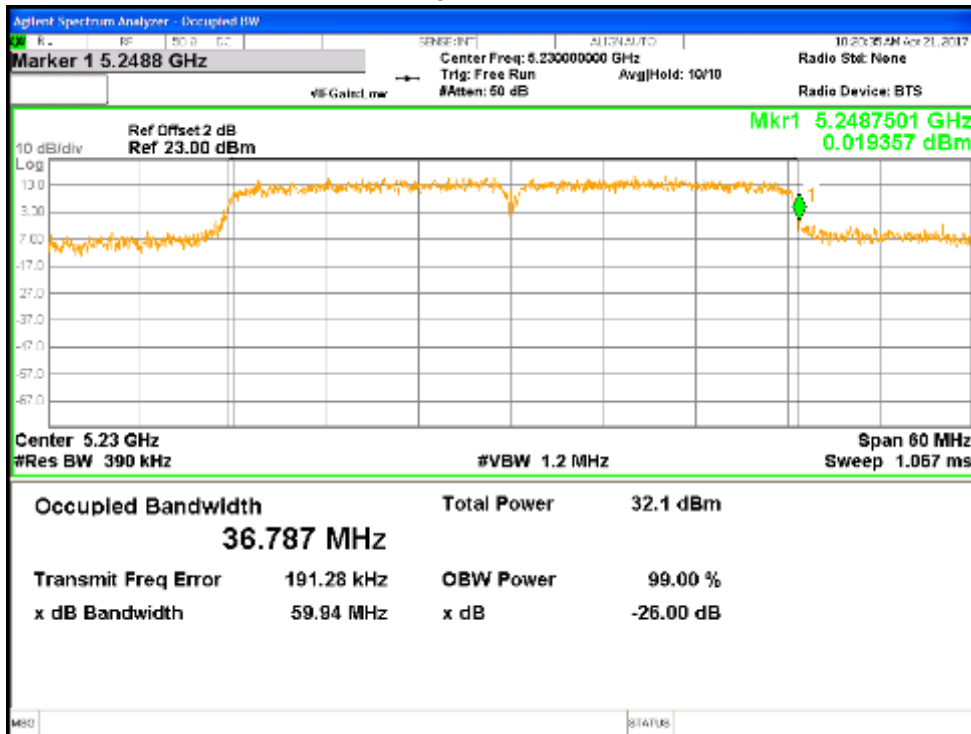

Figure 64: Measured In-Band edge for HT40-MCS0 at 5240 MHz, Chain 1

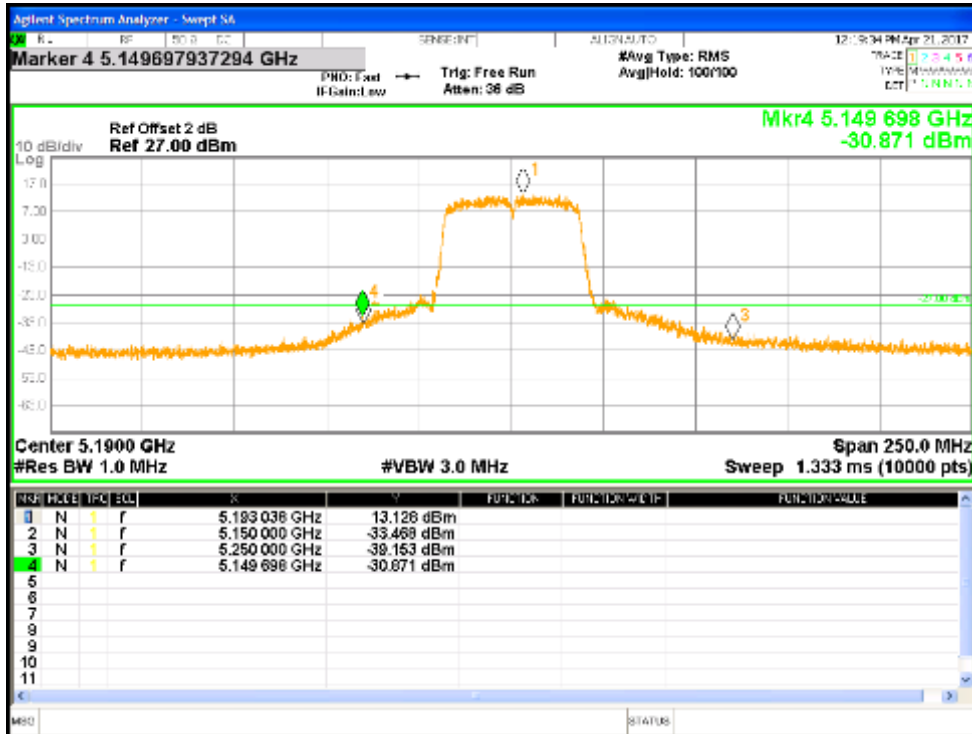

Figure 65: Measured Bandedge for VHT40-MCS0 at 5190 MHz, Chain 0

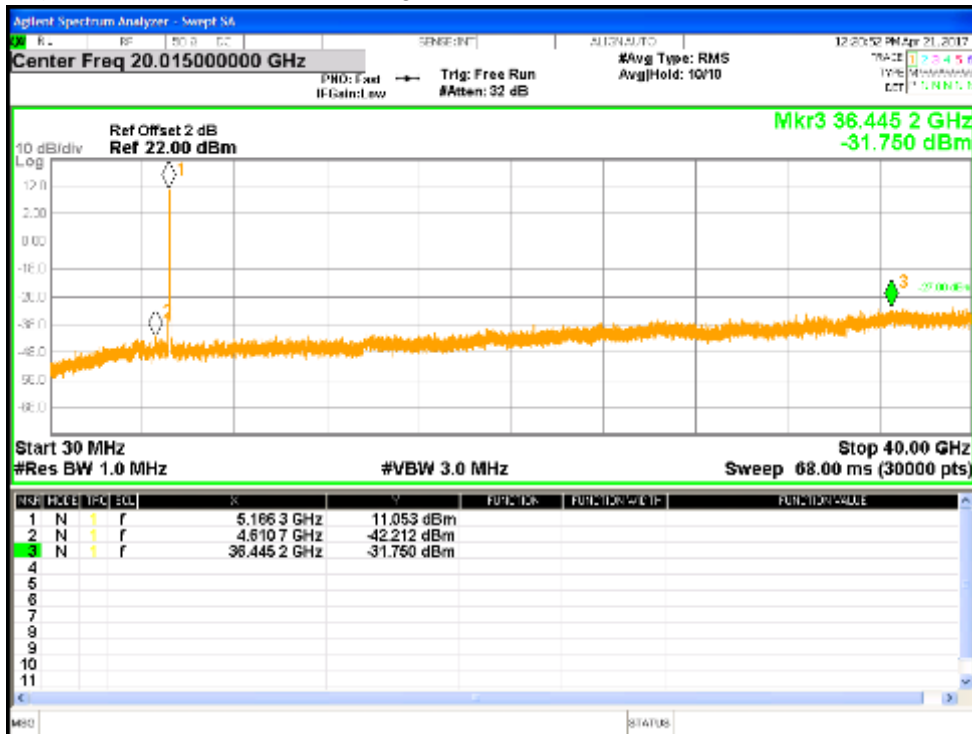

Figure 66: Undesirable Emission for VHT40-MCS0 at 5190 MHz, Chain 0

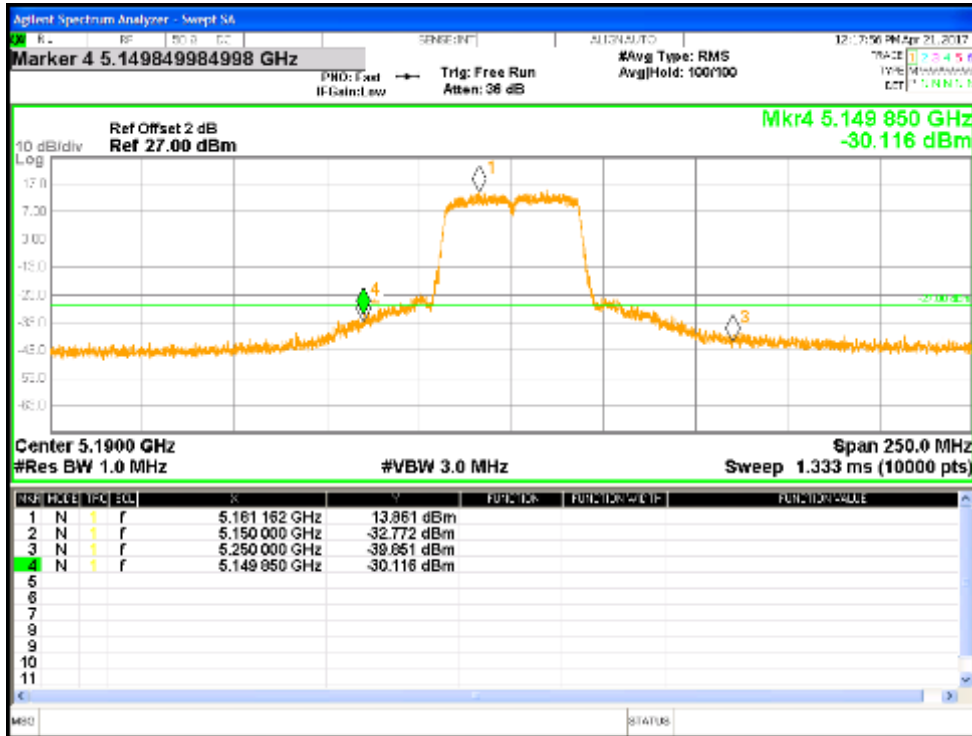

Figure 67: Measured Bandedge for VHT40-MCS0 at 5190 MHz, Chain 1

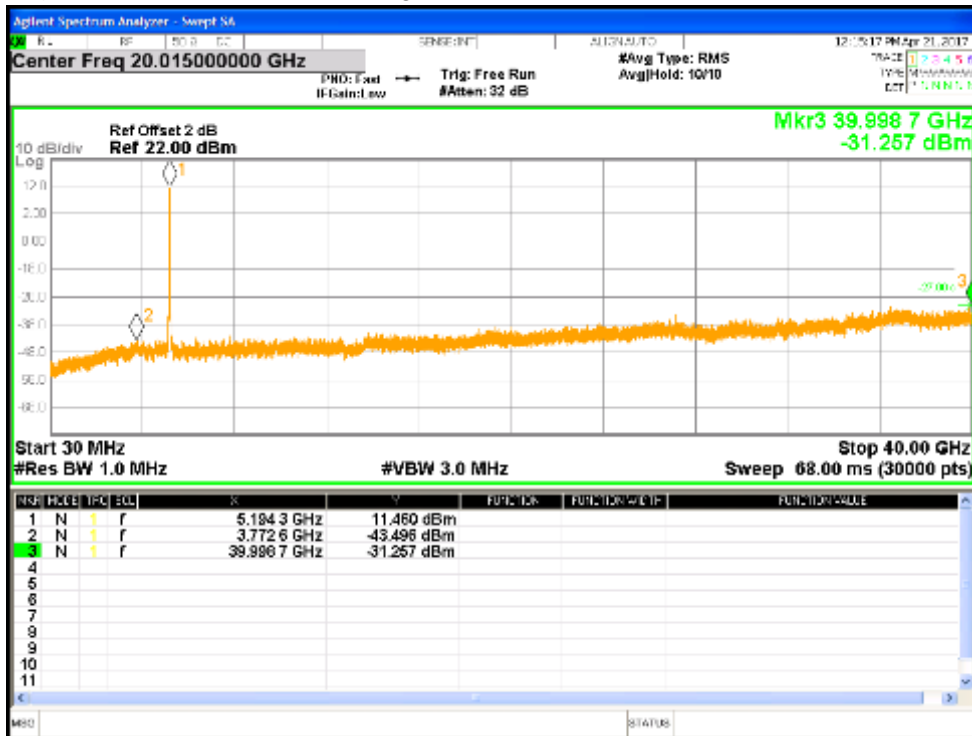

Figure 68: Undesirable Emission for VHT40-MCS0 at 5190 MHz, Chain 1

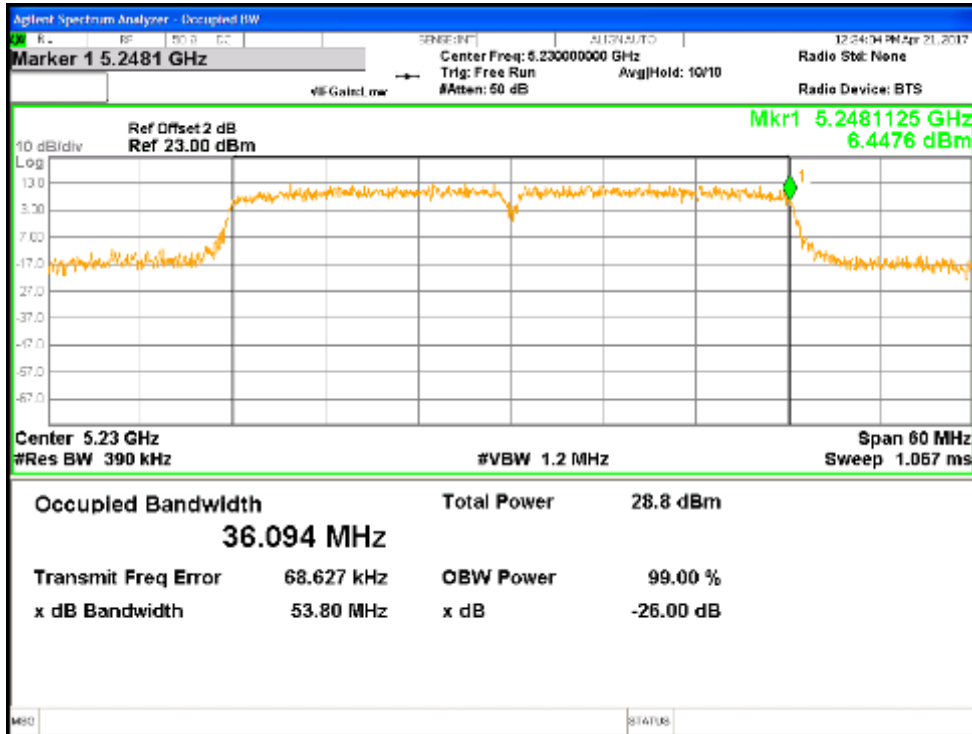

Figure 69: Measured In-Band edge for VHT40-MCS0 at 5240 MHz, Chain 0

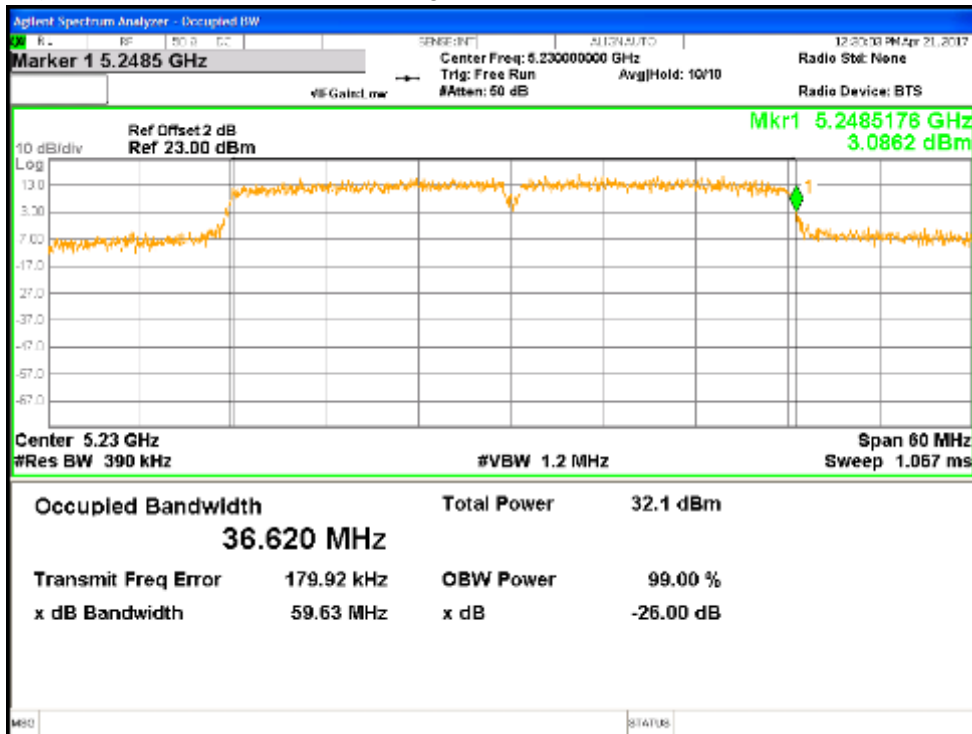

Figure 70: Measured In-Band edge for VHT40-MCS0 at 5240 MHz, Chain 1

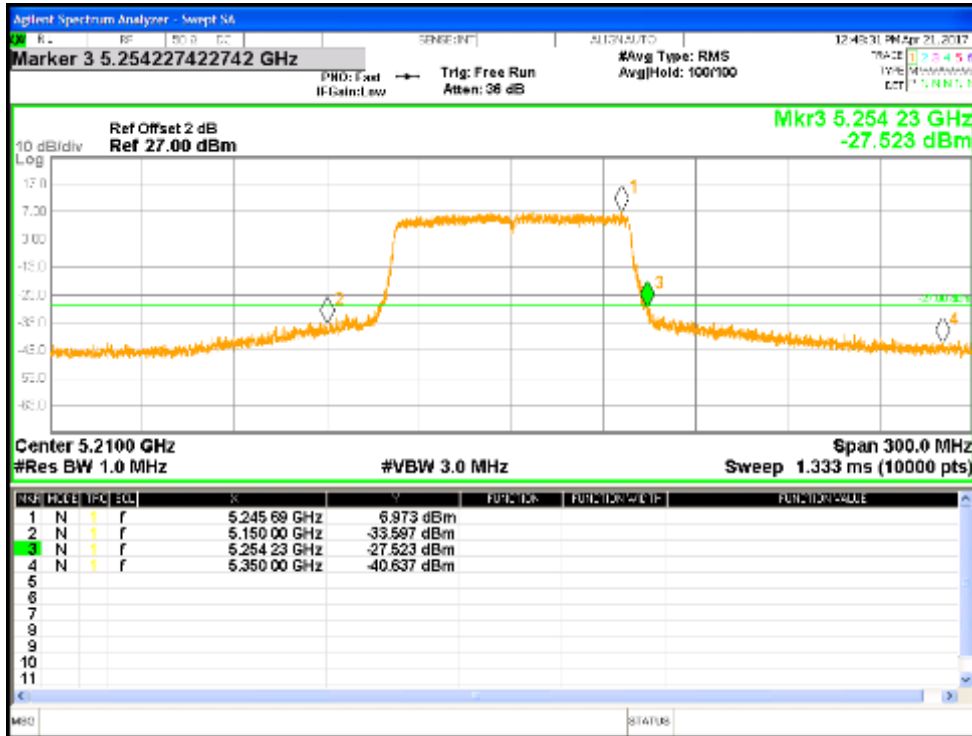

Figure 71: Measured Bandedge for VHT80-MCS0 at 5210 MHz, Chain 0

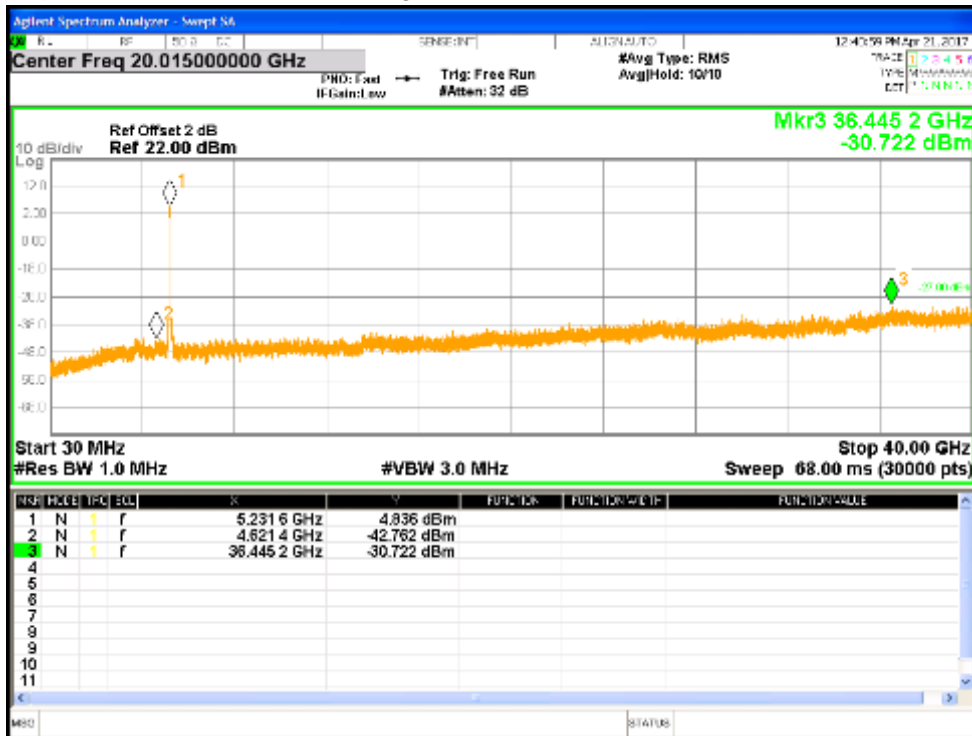

Figure 72: Undesirable Emission for VHT80-MCS0 at 5210 MHz, Chain 0

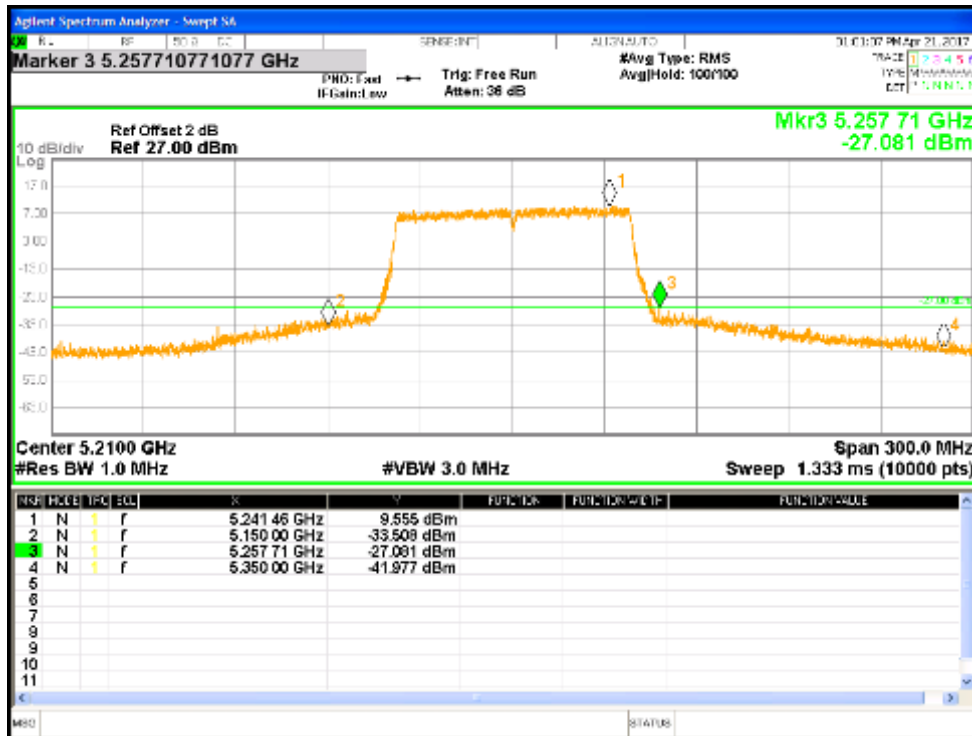

Figure 73: Measured Bandedge for VHT80-MCS0 at 5210 MHz, Chain 1

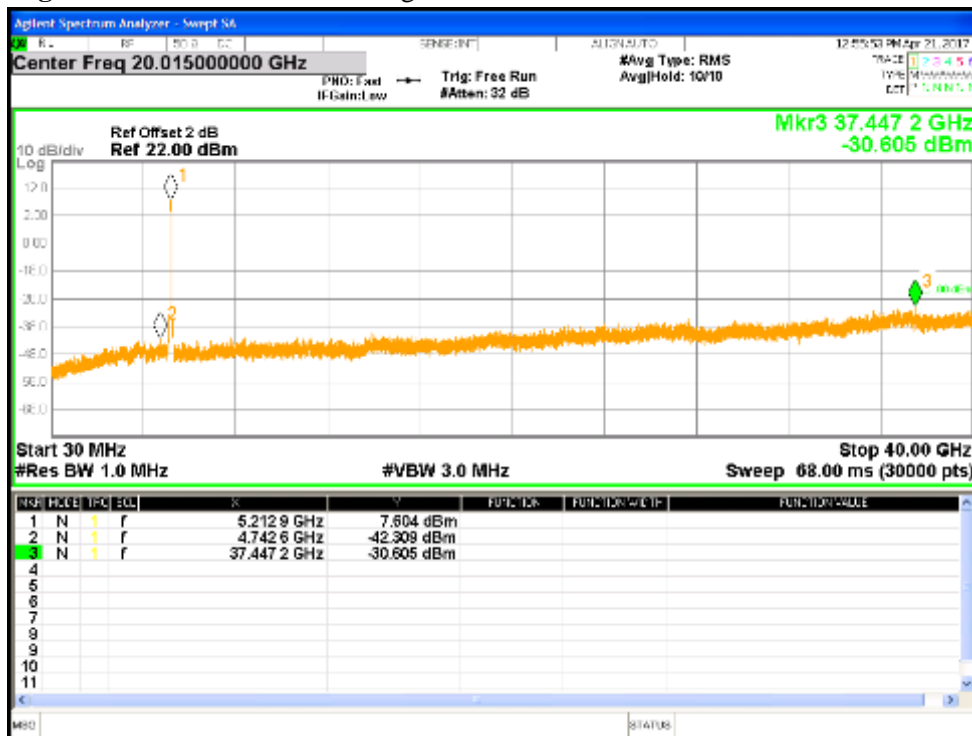

Figure 74: Undesirable Emission for VHT80-MCS0 at 5210 MHz, Chain 1

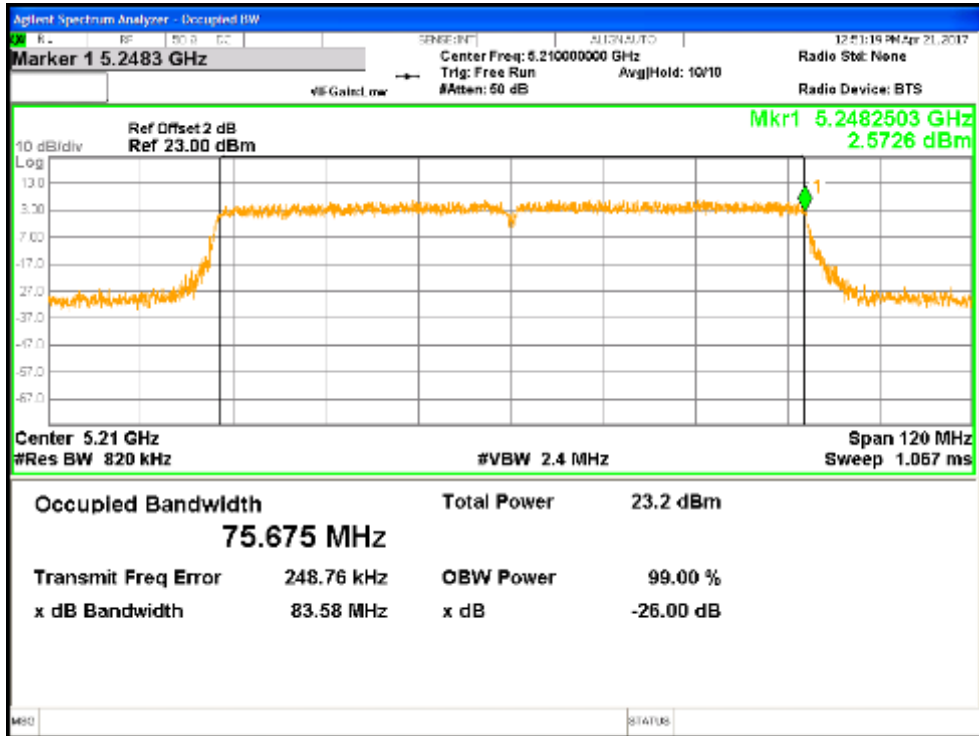

Figure 75: Measured In-Band edge for VHT80-MCS0 at 5240 MHz, Chain 0

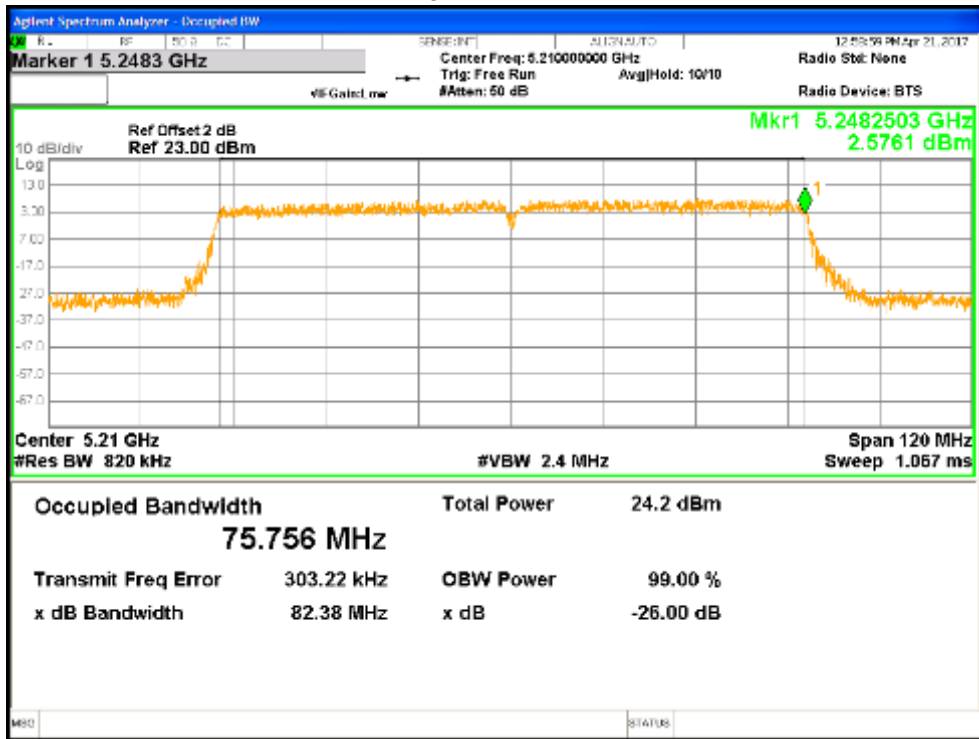

Figure 76: Measured In-Band edge for VHT80-MCS0 at 5240 MHz, Chain 1

4.5 Transmitter Spurious Emissions

Transmitter spurious emissions are emissions outside the frequency range of the equipment when the equipment is in transmit mode; per requirement of CFR47 15.205:2016, 15.209:2016, 15.407(b):2016, RSS 247 Sect. 6:2017, RSS GEN Sect.8.9 and 8.10:2014

4.5.1 Test Methodology

4.5.1.1 Preliminary Test

A test program that controls instrumentation and data logging was used to automate the preliminary RF emission test procedure. The frequency range of interest was divided into sub-ranges to yield a frequency resolution of approximately 120 kHz and provide a reading at each frequency for no more than 12° of turntable rotation. For each frequency sub-range the turntable was rotated 360° while peak emission data was recorded and plotted over the frequency range of interest in horizontal and vertical antenna polarization's.

Preliminary emission profile testing was performed inside the anechoic chamber. The EUT was placed on a 1.0m x 1.5m non-conductive table 80cm (<1 GHz) and 150cm (>1 GHz) above the floor. The EUT was positioned as shown in the setup photographs. The receiving antenna was placed at a distance of 3m at a fixed height of 1m. Measurement equipment was located outside of the chamber. A video camera was placed inside the chamber to view the EUT.

Pres-scans were performed to determine the worst, data rate/ chains for 802.11a, 802.11n (HT20 and HT40), 802.11ac (VHT20, VHT40 and VHT80).

4.5.1.2 Final Test

For each frequency measured, the peak emission was maximized by manipulating the receiving antenna from 1 to 4 meters above the ground plane and placing it at the position that produced the maximum signal strength reading. The turntable was then rotated through 360° while observing the peak signal and placing the EUT at the position that produced maximum radiation. The six highest emissions relative to the limit were measured unless such emissions were more than 20 dB below the limit. If less than six emissions are within 20 dB of the limit, than the noise level of the receiver is measured at frequencies where emissions are expected. Multiples of all oscillator and microprocessor frequencies were also checked.

Final testing was performed on an NSA compliant test site. The EUT was placed on a 1.0m x 1.5m non-conductive table 80cm (<1 GHz) and 150cm (>1 GHz) above the ground plane. The placement of EUT and cables were the same as for preliminary testing and is shown in the setup photographs.

Final results are:

1. 802.11a at 6Mbps with 2 Chains (covering HT20 & VHT20)
2. HT40 at MCS0 with 2 Chains (covering VHT40)
3. VHT80 at MCS0 with 2 Chains

4.5.1.3 Deviations

None.

Test Setup:

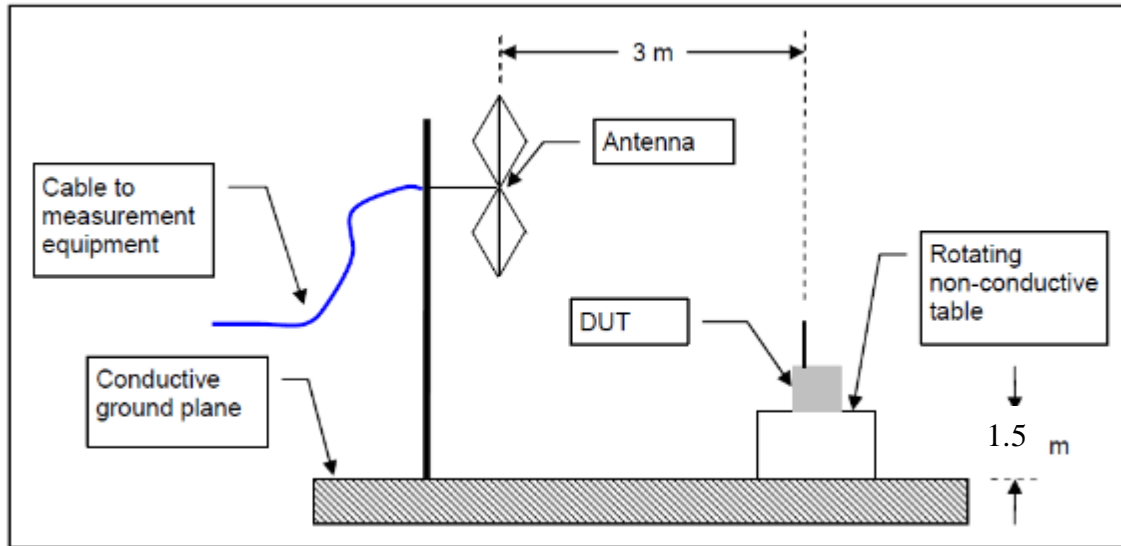

4.5.2 Transmitter Spurious Emission Limit

The spurious emissions of the transmitter shall not exceed the values in CFR47 Part 15.205, 15.209, RSS 247 Sect. 6, RSS GEN Sect. 8.9 and 8.10

Frequency (MHz)	Field strength (microvolts/meter)	Measurement distance (meters)
0.009-0.490	2400/F (kHz)	300
0.490-1.705	24000/F (kHz)	30
1.705-30.0	30	30
30-88	100 **	3
88-216	150 **	3
216-960	200 **	3
Above 960	500	3

According to CFR47 15.407 (b) and RSS 247 Sect. 6.2.1.2, all harmonics and spurious emissions which are outside the 5150 MHz - 5250 MHz, 5250 MHz – 5350 MHz, or 5470 MHz – 5725 MHz shall not exceed -27 dBm/MHz. This is equivalent to 68.2 dBuV/m at 3 meter distance.

4.5.3 Results

The final measurement data was taken under the worst case operating modes, configurations, and/or cable positions. It also reflects the results including any modifications and/or special accessories listed in Sections 1.4 and test plan.

As originally tested, the EUT was found to be compliant to the requirements of the test standard(s).

Table 22: Transmit Spurious Emission at Band-Edge Requirements

Test Conditions: Radiated Measurement, Normal Temperature and Voltage only								
Antenna Type: FPCB			Power Setting: See test plan					
Max. Directional Gain: Antenna 1 = + 3.01 dBi; Antenna 3 = + 4.58 dBi								
Total Directional Gain: + 6.84 dBi								
Signal State: Modulated at 100%.								
Ambient Temp.: 19° C				Relative Humidity: 35%				
Band-Edge Results								
Freq. (MHz)	Level (dBuV/m)	Pol. (H/V)	Limit (dBuV/m)	Margin (dB)	Det.	Table Deg.	Tower (cm)	Note
5150.0	66.23	H	74.00	-7.77	Pk	141	144	PLOT 76: 11a-6Mbps-5180MHz-TP23.5-Ch0 & Ch1
5150.0	53.07	H	54.00	-0.93	Ave	141	144	PLOT 77: 11a-6Mbps-5180MHz- TP23.5-Ch0 & Ch1
5150.0	65.18	V	74.00	-8.82	Pk	353	112	PLOT 78: 11a-6Mbps-5180MHz- TP23.5-Ch0 & Ch1
5150.0	52.21	V	54.00	-1.79	Ave	353	112	PLOT 79: 11a-6Mbps-5180MHz- TP23.5-Ch0 & Ch1
5149.0	67.42	H	74.00	-6.58	Pk	92	105	PLOT 80: HT20-MCS0-5180MHz- TP24-Ch0_Ch1
5150.0	53.33	H	54.00	-0.67	Ave	92	105	PLOT 81: HT20-MCS0-5180MHz- TP24-Ch0_Ch1
5150.0	67.23	V	74.00	-6.77	Pk	349	108	PLOT 82: HT20-MCS0-5180MHz- TP24-Ch0_Ch1
5150.0	53.27	V	54.00	-0.73	Ave	349	108	PLOT 83: HT20-MCS0-5180MHz- TP24-Ch0_Ch1
5144.8	66.46	H	74.00	-7.54	Pk	134	121	PLOT 84: HT40-MCS0-5190MHz-TP20.5-Ch0_Ch1
5145.1	51.97	H	54.00	-2.03	Ave	134	121	PLOT 85: HT40-MCS0-5190MHz-TP20.5-Ch0_Ch1
5149.1	64.18	V	74.00	-9.82	Pk	345	111	PLOT 86: HT40-MCS0-5190MHz-TP20.5-Ch0_Ch1
5142.1	49.86	V	54.00	-4.14	Ave	345	111	PLOT 87: HT40-MCS0-5190MHz-TP20.5-Ch0_Ch1
<p>Note: 1. Band-edge frequencies were taken at 5150 MHz since 5250-5350 MHz band is not a restricted band. 2. All the band-edge measurements met the restricted band requirements of CFR47 15.205. 3. For 5250 MHz In-band-edge, refer to Section 4.4.2. 4. Power level is the same for both HT20 & VHT20. HT20 found as worst case, therefore VHT20 is covered for band-edge measurements.</p>								

Table 23: Transmit Spurious Emission at Band-Edge Requirements Continued

Test Conditions: Radiated Measurement, Normal Temperature and Voltage only								
Antenna Type: FPCB			Power Setting: See test plan					
Max. Directional Gain: Antenna 1 = + 3.01 dBi; Antenna 3 = + 4.58 dBi								
Total Directional Gain: + 6.84 dBi								
Signal State: Modulated at 100%.								
Ambient Temp.: 19° C				Relative Humidity: 35%				
Band-Edge Results								
Freq. (MHz)	Level (dBUV/m)	Pol. (H/V)	Limit (dBUV/m)	Margin (dB)	Det.	Table Deg.	Tower (cm)	Note
5150.0	68.02	H	74.00	-5.98	Pk	137	107	PLOT 88: VHT40-MCS0-5190MHz-TP20-Ch0_Ch1
5150.0	53.94	H	54.00	-0.06	Ave	137	107	PLOT 89: VHT40-MCS0-5190MHz-TP20-Ch0_Ch1
5149.3	67.51	V	74.00	-6.49	Pk	349	112	PLOT 90: VHT40-MCS0-5190MHz-TP20-Ch0_Ch1
5150.0	52.35	V	54.00	-1.65	Ave	349	112	PLOT 91: VHT40-MCS0-5190MHz-TP20-Ch0_Ch1
5143.2	69.10	H	74.00	-4.90	Pk	134	109	PLOT 92: VHT80-MCS0-5210MHz-TP19-Ch0_Ch1
5143.4	53.23	H	54.00	-0.77	Ave	134	109	PLOT 93: VHT80-MCS0-5210MHz-TP19-Ch0_Ch1
5146.3	66.10	V	74.00	-7.90	Pk	4	128	PLOT 94: VHT80-MCS0-5210MHz-TP19-Ch0_Ch1
5147.4	51.23	V	54.00	-2.77	Ave	4	128	PLOT 95: VHT80-MCS0-5210MHz-TP19-Ch0_Ch1
<p>Note: 1. Band-edge frequencies were taken at 5150 MHz since 5250-5350 MHz band is not a restricted band. 2. All the band-edge measurements met the restricted band requirements of CFR47 15.205. 3. For 5250 MHz In-band-edge, refer to Section 4.4.2.</p>								

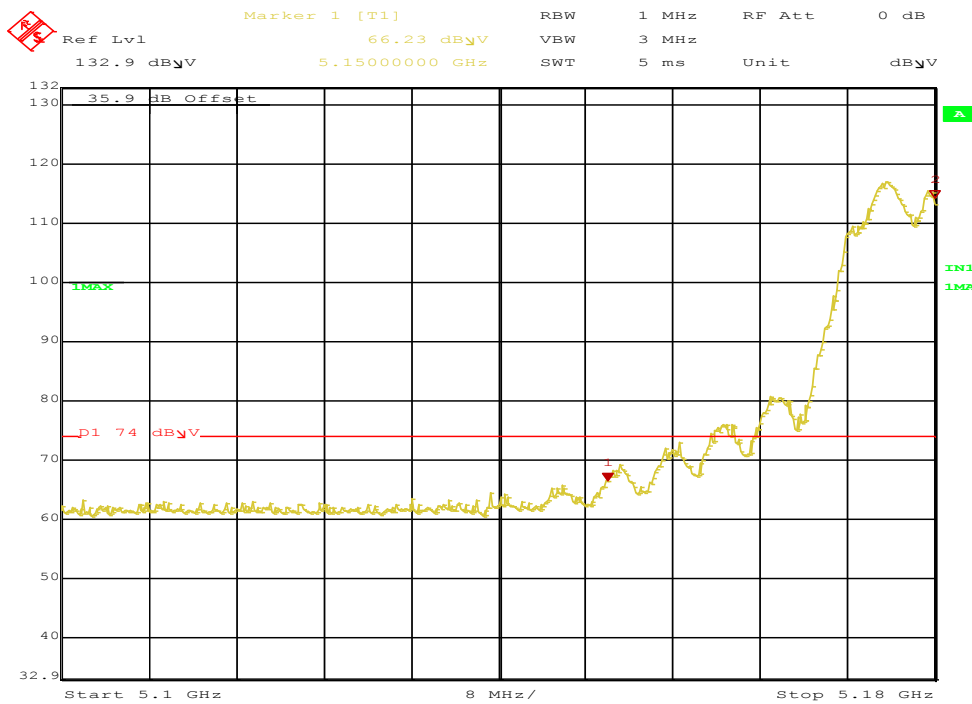

Date: 5.APR.2017 17:21:43

Figure 77: Radiated Emission 5150.0 MHz Edge for 11a 5180 MHz – Horz. (Pk)

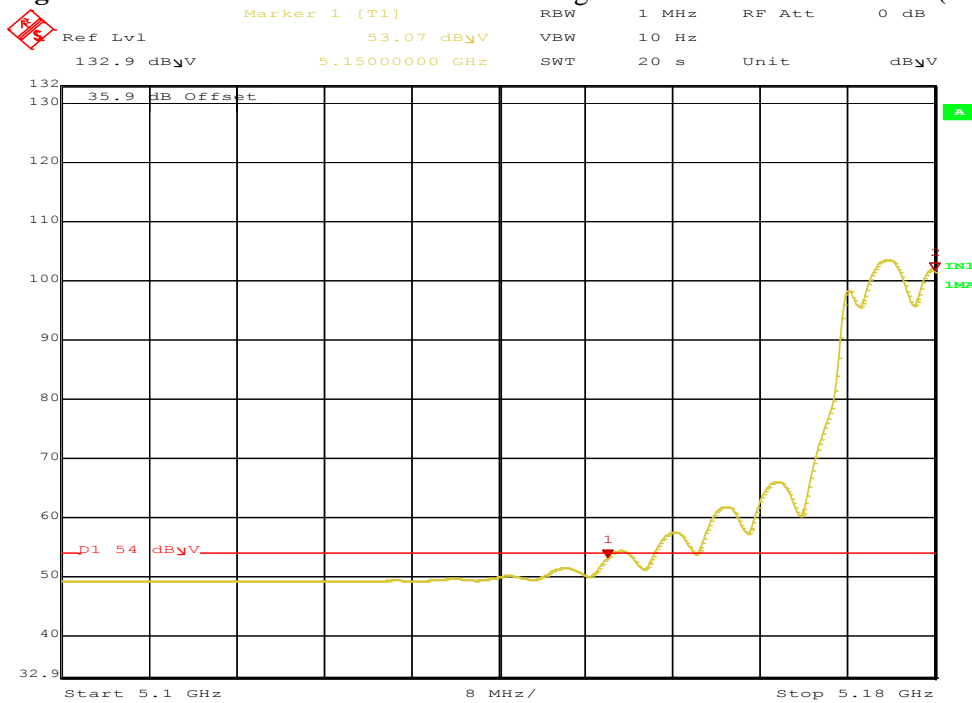

Date: 5.APR.2017 17:20:21

Figure 78: Radiated Emission 5150.0 MHz Edge for 11a 5180 MHz – Horz. (Ave)

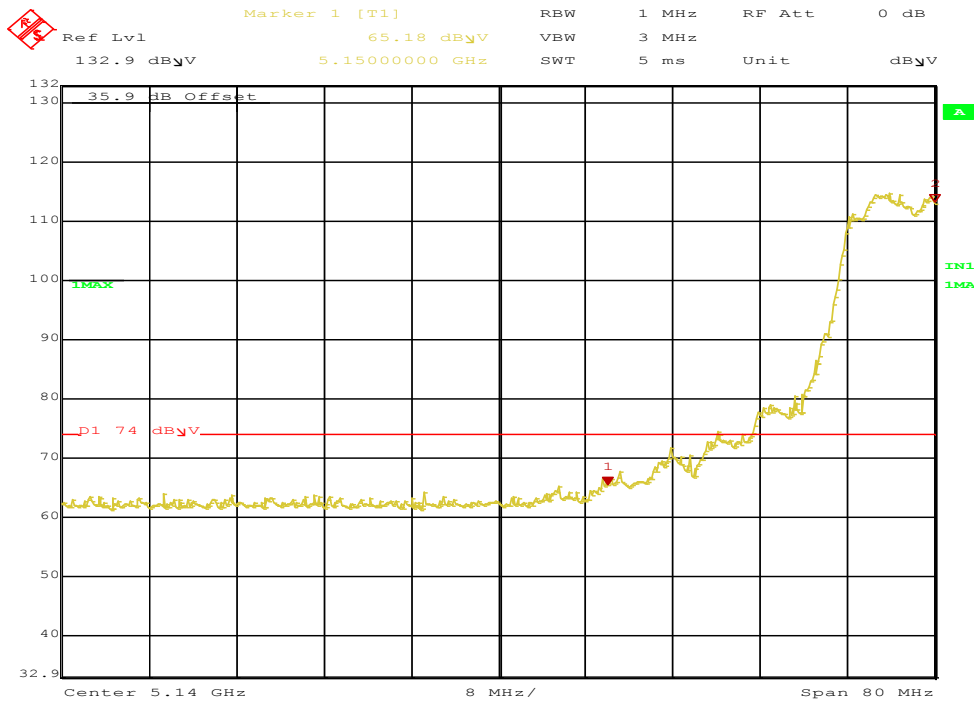

Date: 5.APR.2017 17:24:48

Figure 79: Radiated Emission 5150.0 MHz Edge for 11a 5180 MHz – Vert. (Pk)

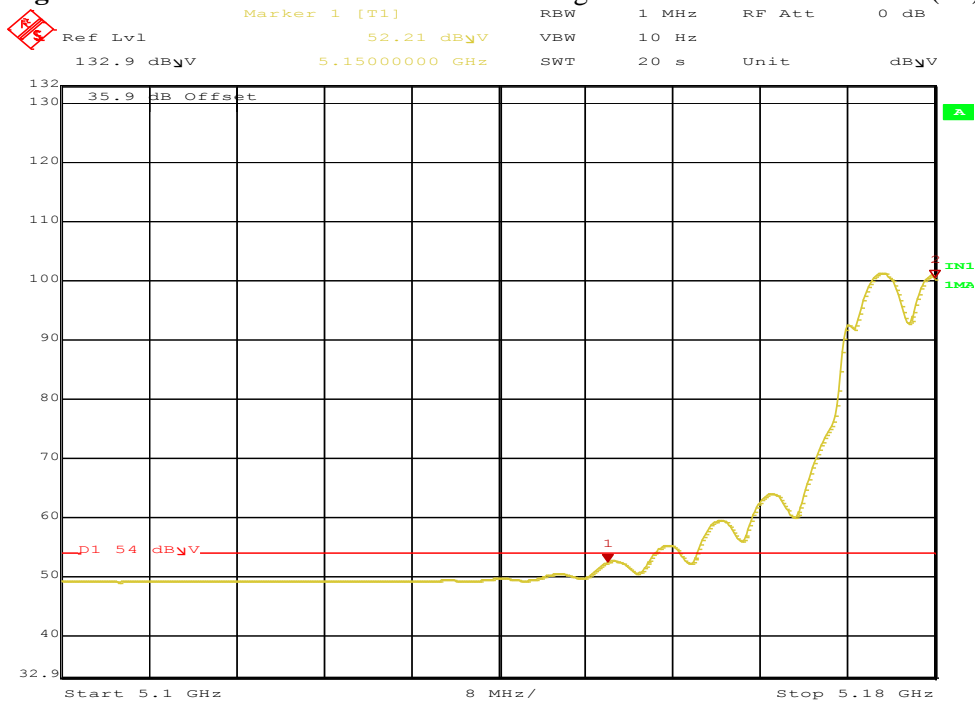

Date: 5.APR.2017 17:25:53

Figure 80: Radiated Emission 5150.0 MHz Edge for 11a 5180 MHz – Vert. (Ave)

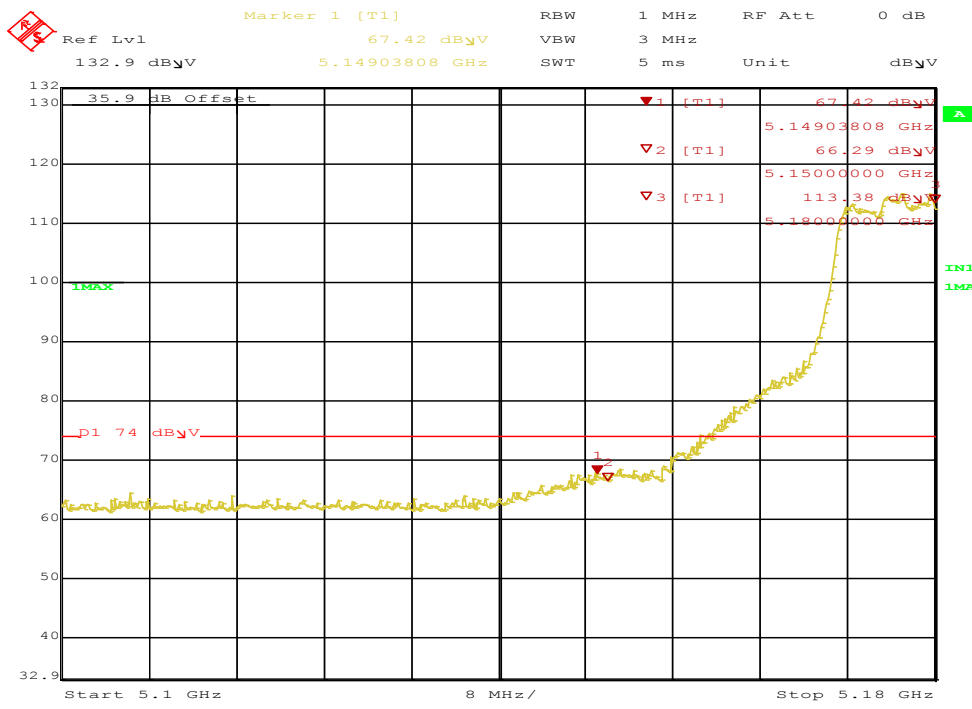

Figure 81: Radiated Emission 5149.0 MHz Edge for HT20 5180 MHz – Horz. (Pk)

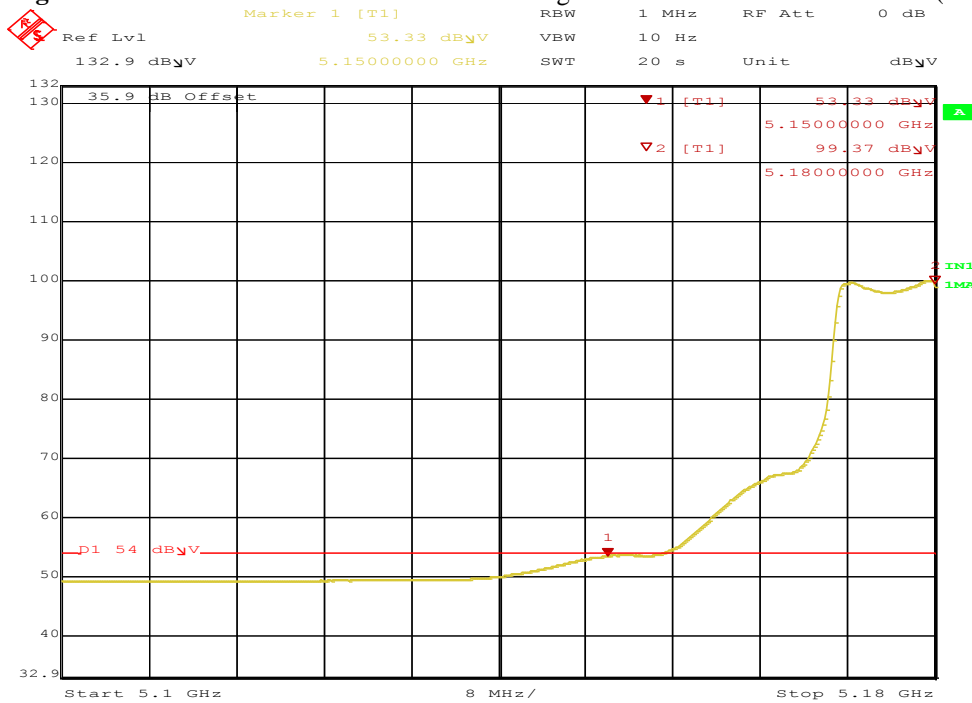
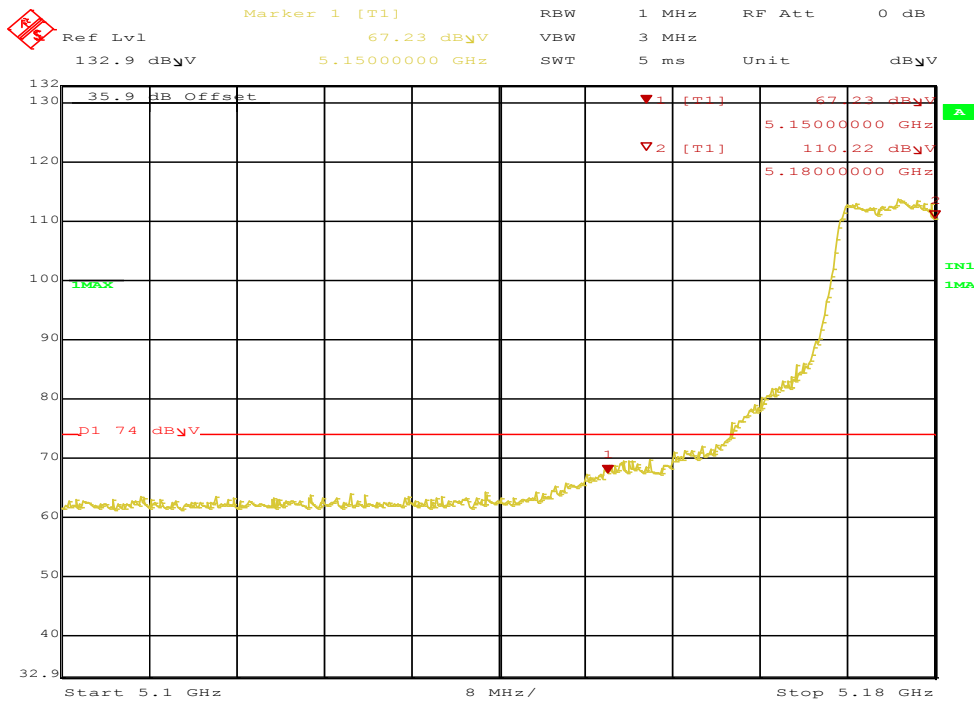
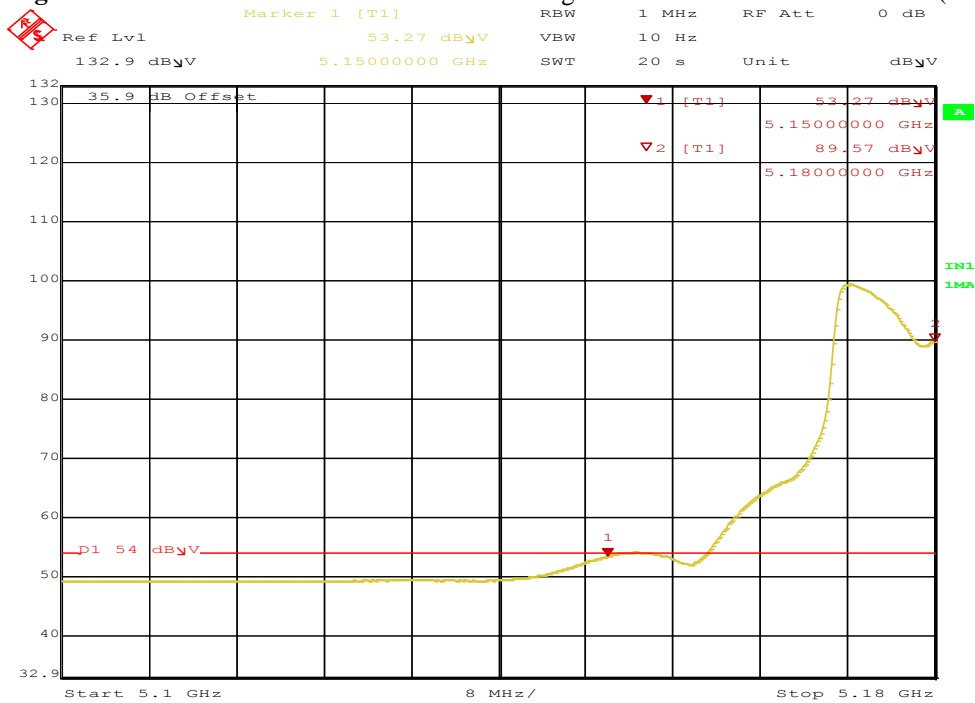

Figure 82: Radiated Emission 5150.0 MHz Edge for HT20 5180 MHz – Horz. (Ave)



Date: 5.APR.2017 17:39:41

Figure 83: Radiated Emission 5150.0 MHz Edge for HT20 5180 MHz – Vert. (Pk)



Date: 5.APR.2017 17:40:56

Figure 84: Radiated Emission 5150.0 MHz Edge for HT20 5180 MHz – Vert. (Ave)

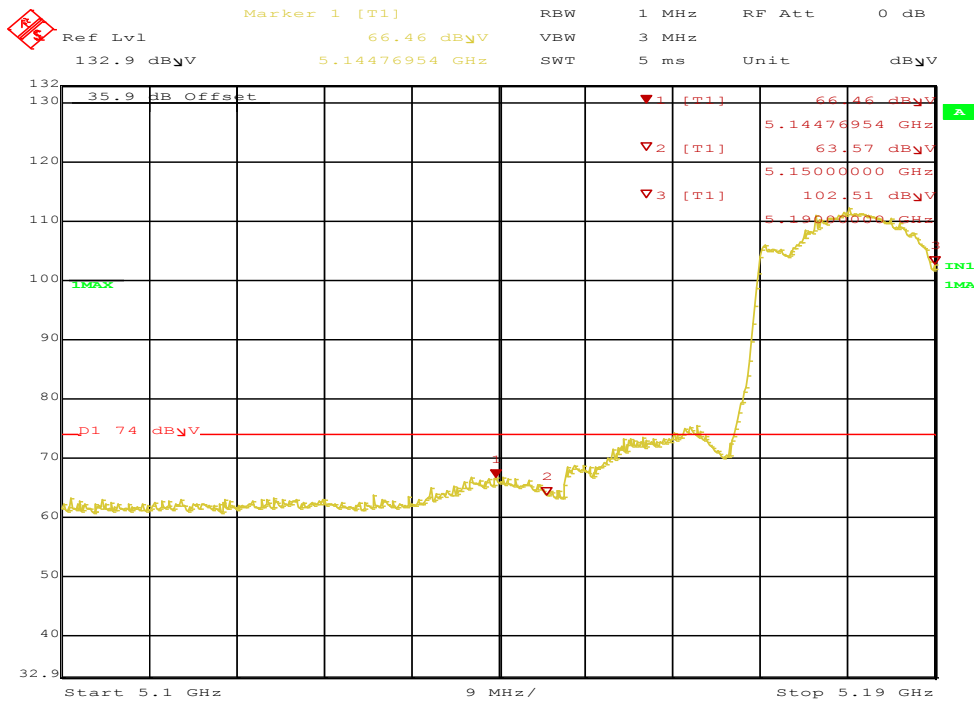

Date: 5.APR.2017 17:53:59

Figure 85: Radiated Emission 5144.8 MHz Edge for HT40 5190 MHz – Horz. (Pk)

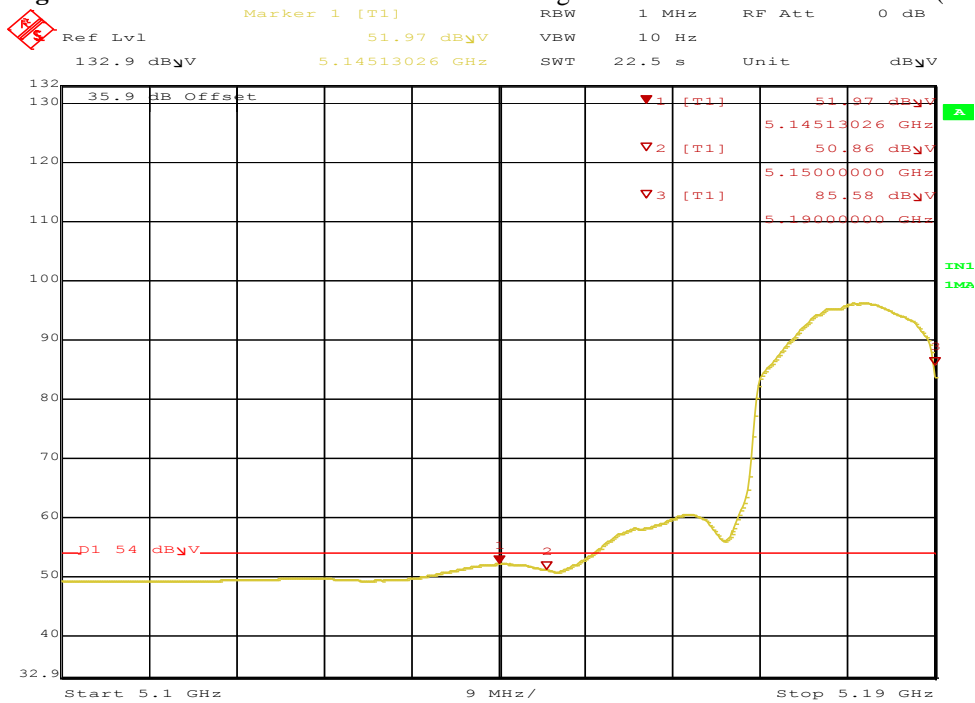

Date: 5.APR.2017 17:52:20

Figure 86: Radiated Emission 5145.1 MHz Edge for HT40 5190 MHz – Horz. (Ave)

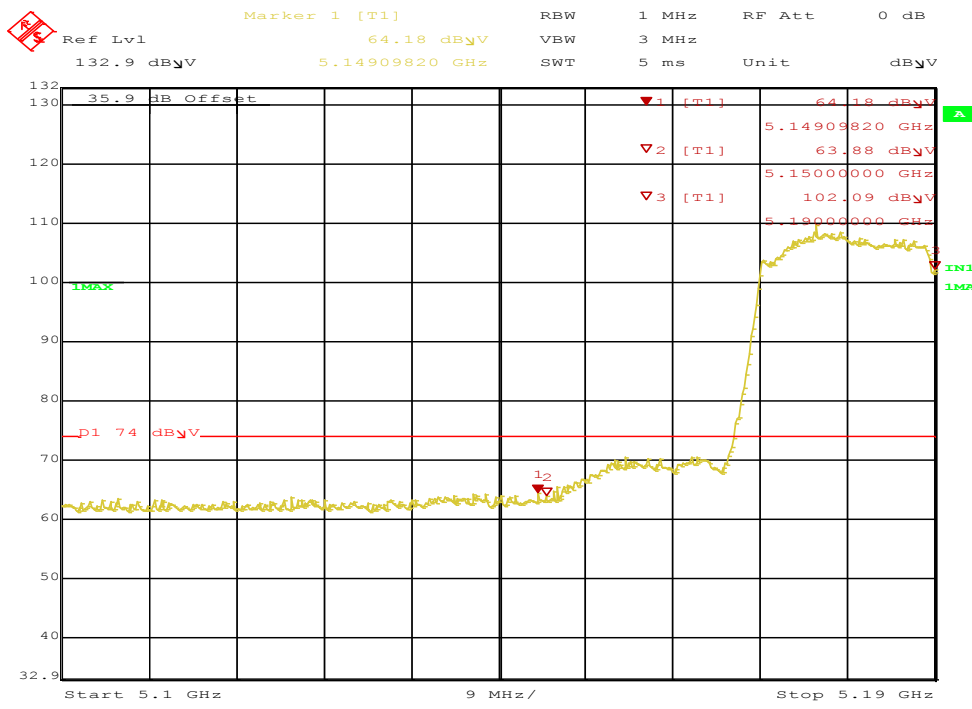

Date: 5.APR.2017 17:56:35

Figure 87: Radiated Emission 5149.1 MHz Edge for HT40 5190 MHz – Vert. (Pk)

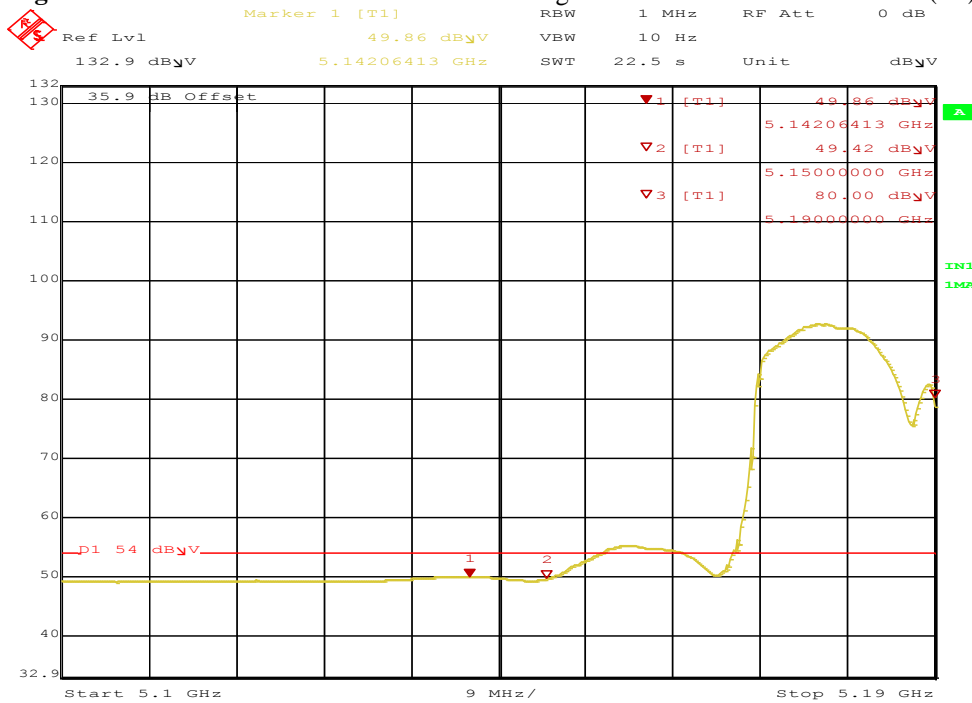

Date: 5.APR.2017 17:57:46

Figure 88: Radiated Emission 5142.1 MHz Edge for HT40 5190 MHz – Vert. (Ave)

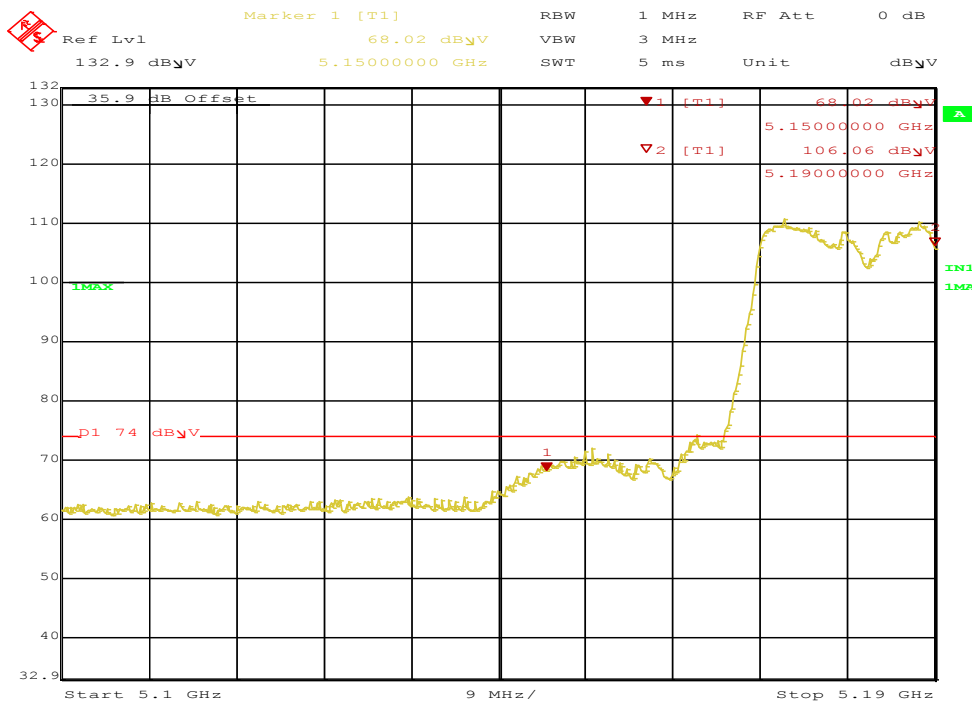

Date: 5.APR.2017 18:04:25

Figure 89: Radiated Emission 5150.0 MHz Edge for VHT40 5190 MHz – Horiz. (Pk)

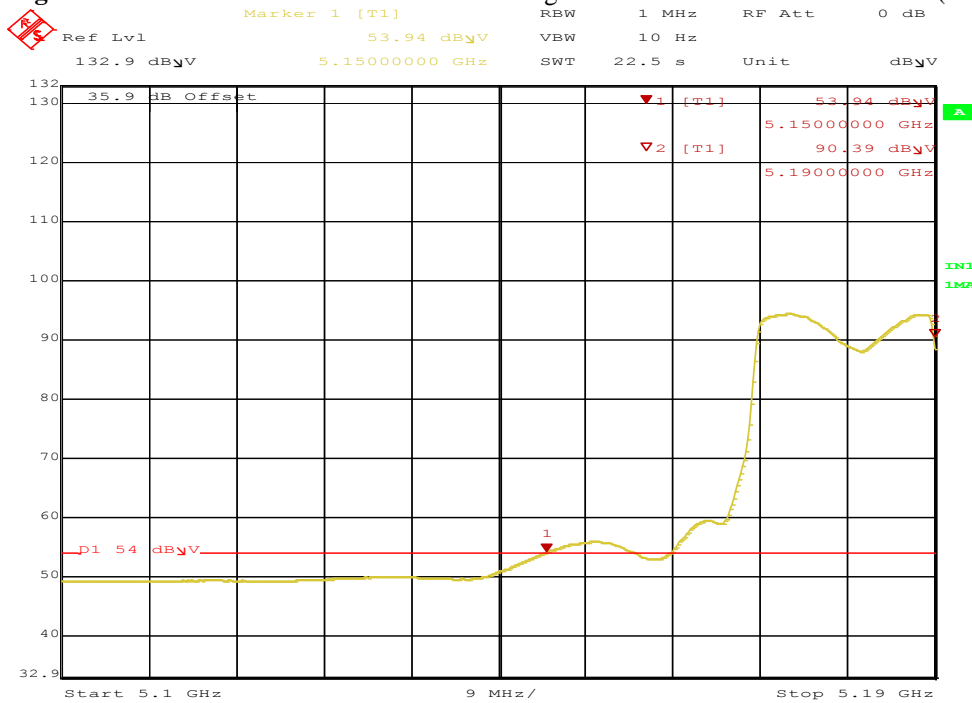

Date: 5.APR.2017 18:03:14

Figure 90: Radiated Emission 5150.0 MHz Edge for VHT40 5190 MHz – Horiz. (Ave)

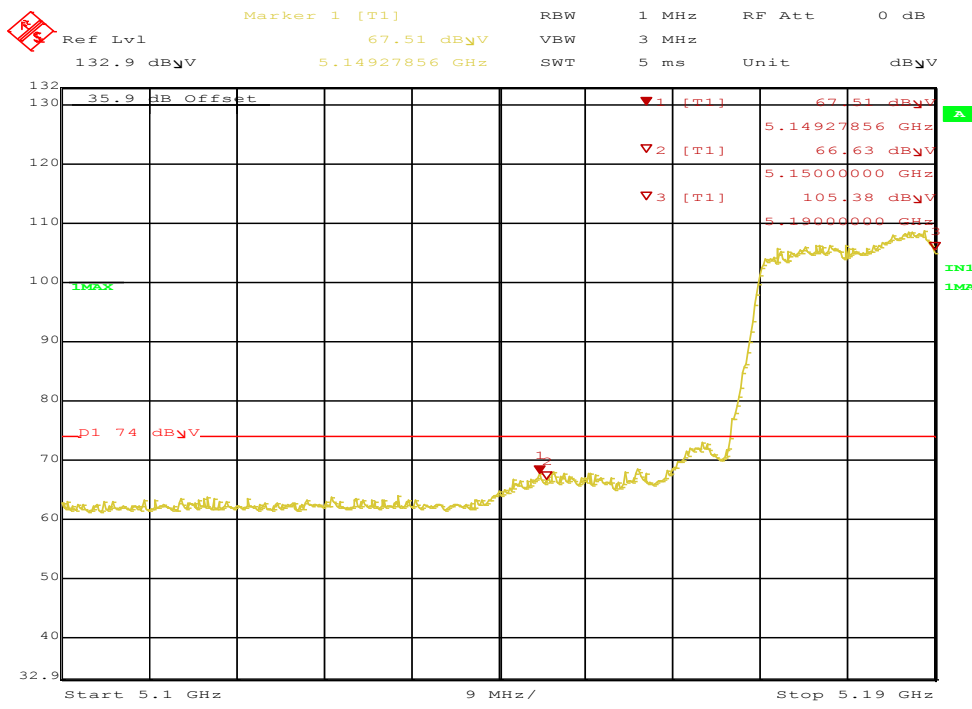

Date: 5.APR.2017 18:06:43

Figure 91: Radiated Emission 5149.3 MHz Edge for VHT40 5190 MHz – Vert. (Pk)

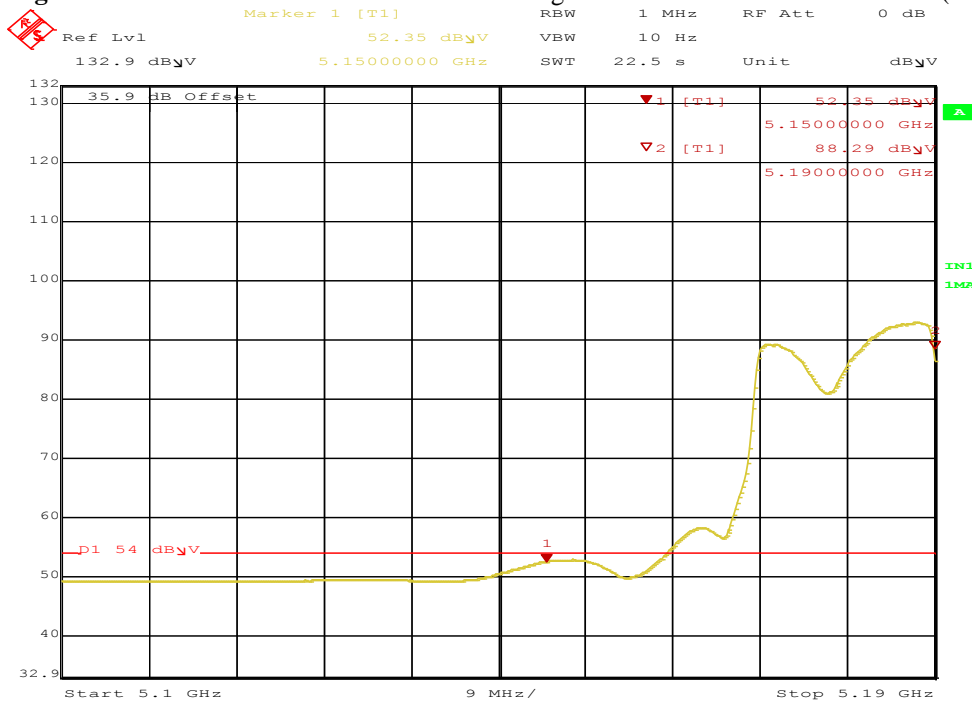

Date: 5.APR.2017 18:07:41

Figure 92: Radiated Emission 5150.0 MHz Edge for VHT40 5190 MHz – Vert. (Ave)

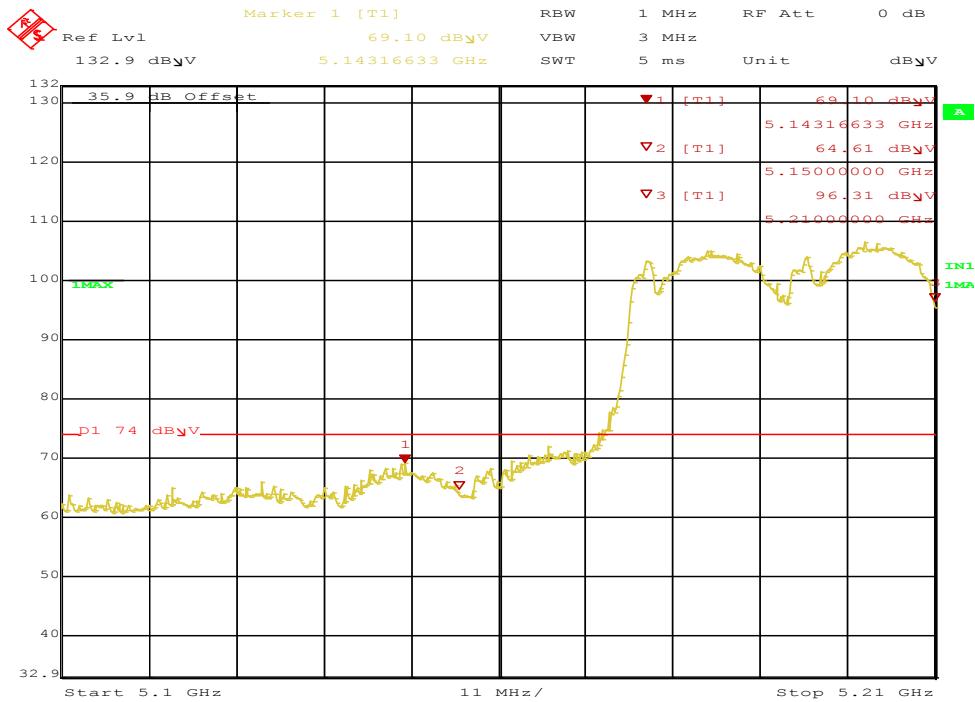

Date: 5.APR.2017 18:13:35

Figure 93: Radiated Emission 5143.2 MHz Edge for VHT80 5210 MHz – Horz. (Pk)

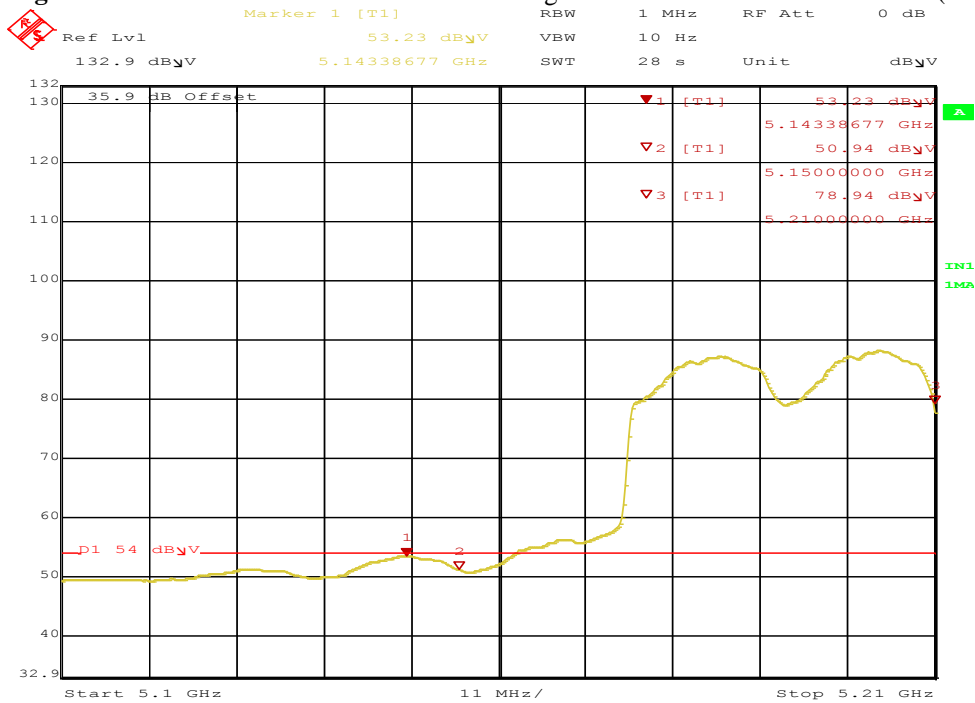

Date: 5.APR.2017 18:12:20

Figure 94: Radiated Emission 5143.4 MHz Edge for VHT80 5210 MHz – Horz. (Ave)

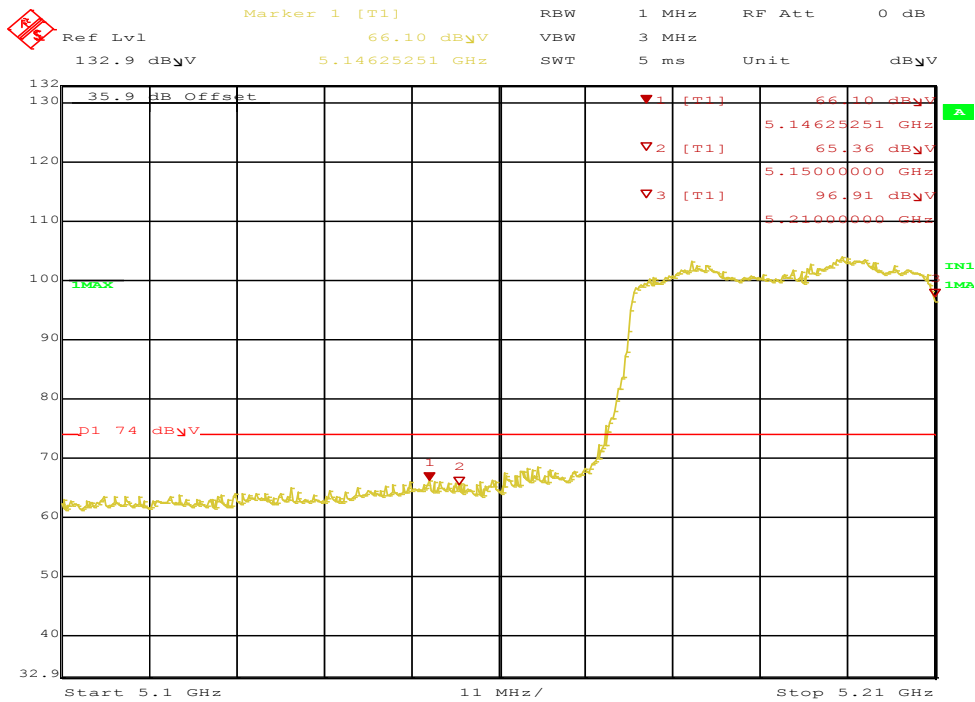

Date: 5.APR.2017 18:15:32

Figure 95: Radiated Emission 5146.3 MHz Edge for VHT80 5210 MHz – Vert. (Pk)

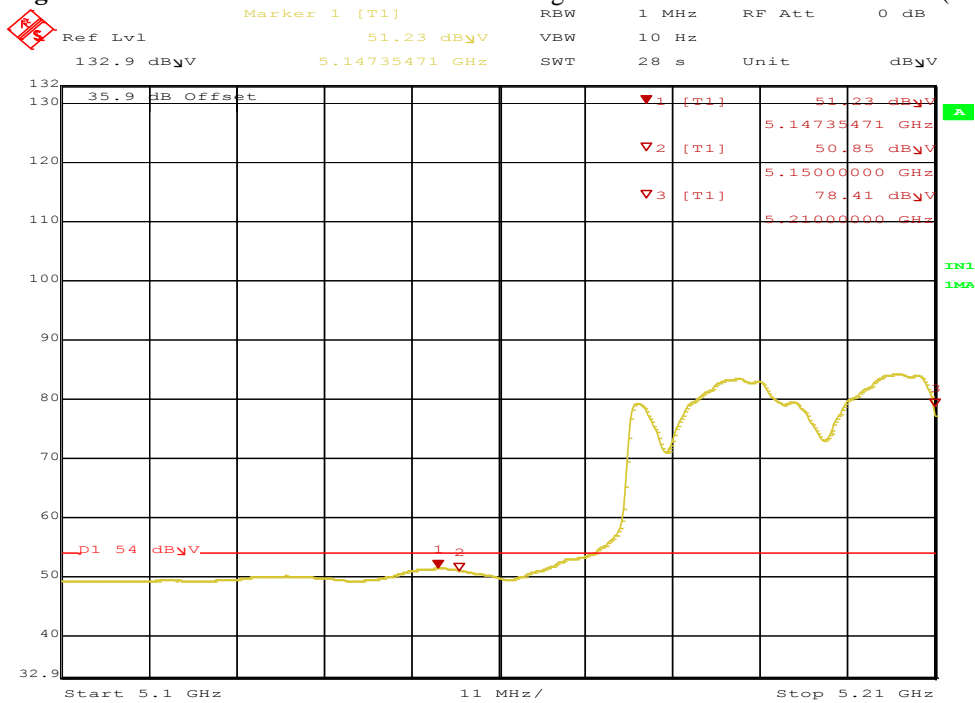

Date: 5.APR.2017 18:16:53

Figure 96: Radiated Emission 5147.4 MHz Edge for VHT80 5210 MHz – Vert. (Ave)

SOP 1 Radiated Emissions		Tracking # 31761399.001 Page 1 of 13	
EUT Name	Wi-Fi Router	Date	Apr 11, 2017
EUT Model	B010001 (USA), B010002 (IC)	Temp / Hum in	22° C / 37%rh
EUT Serial	SPE28JY	Temp / Hum out	N/A
EUT Config.	802.11a at 6Mbps / chain 0 & 1	Line AC / Freq	120 Vac / 60 Hz
Standard	CFR47 Part 15 Subpart C, RSS-247, RSS-GEN	RBW / VBW	120 kHz/ 300 kHz
Dist/Ant Used	3m / JB3	Performed by	Kerwinn Corpuz

30 MHz – 1 GHz Transmit at 5240 MHz

Frequency	Raw	Cable Loss	AF	Level	Detector	Polarity	Height	Azimuth	Limit	Margin
MHz	dBuV/m	dB	dB	dBuV/m		H/V	cm	deg	dBuV/m	dB
38.99	49.04	2.64	-17.33	34.35	QP	V	134	78	40.00	-5.65
47.03	54.28	2.71	-22.45	34.54	QP	V	107	4	40.00	-5.46
79.31	56.22	2.94	-24.44	34.72	QP	V	111	42	40.00	-5.28
94.39	46.89	3.03	-23.77	26.14	QP	V	116	254	43.50	-17.36
145.73	44.74	3.30	-19.45	28.59	QP	V	110	146	43.50	-14.92
174.43	47.17	3.43	-20.57	30.04	QP	V	110	92	43.50	-13.47

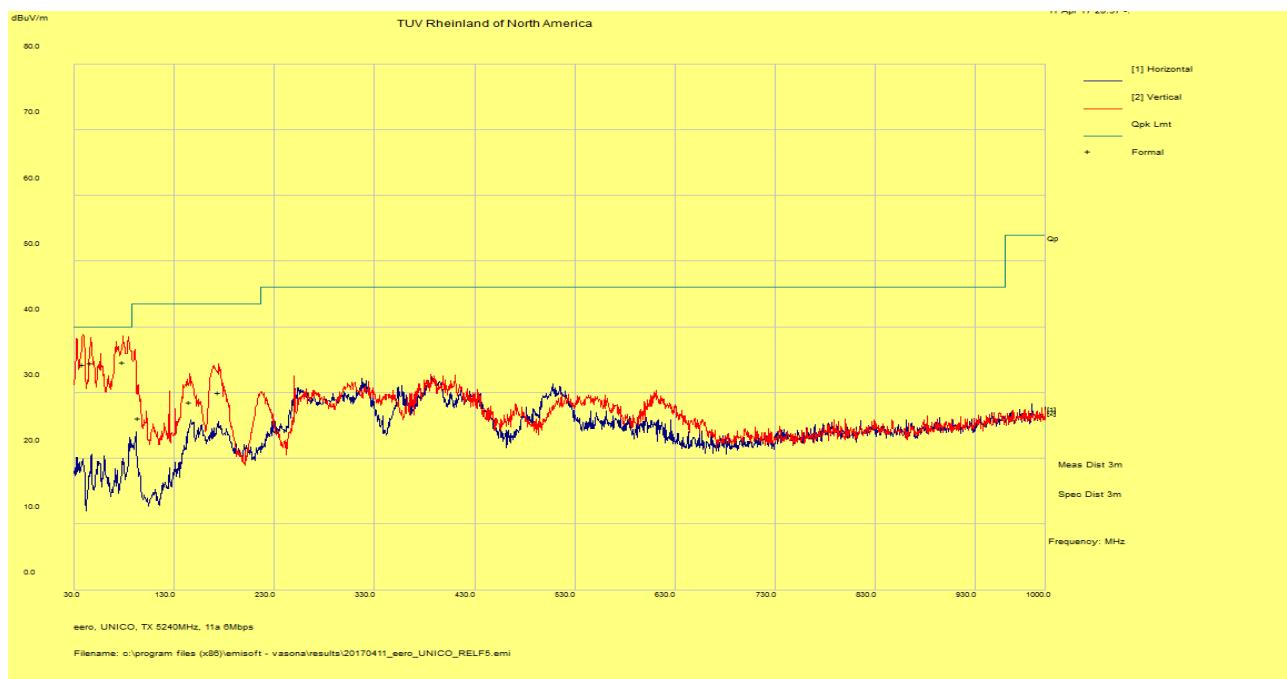

Spec Margin = E-Field QP - Limit, E-Field QP = FIM QP+ Total CF ± Uncertainty

Total CF= AF+ Cable Loss AF= Antenna factor + Preamp

- Note: 1. Worst case was observed on Mid channel of 802.11a 6Mbps mode for 20MHz channel BW.
 2. Mode tested are 802.11a, HT20, VHT20, HT40, VHT40 & VHT80 (low, mid & high channel).
 3. No significant emission was observed below 30MHz.
 4. To reduce complexity and bulkiness of the report Worst case Plots are placed in the report.

SOP 1 Radiated Emissions

Tracking # 31761399.001 Page 2 of 13

EUT Name	Wi-Fi Router	Date	Apr 10, 2017
EUT Model	B010001 (USA), B010002 (IC)	Temp / Hum in	21° C / 40%rh
EUT Serial	SPE28JY	Temp / Hum out	N/A
EUT Config.	802.11a at 6Mbps / chain 0 & 1	Line AC / Freq	120 Vac / 60 Hz
Standard	CFR47 Part 15 Subpart C, RSS-247, RSS-GEN	RBW / VBW	1 MHz/ 3 MHz
Dist/Ant Used	3m - EMCO3115 / 1m - AHA-840	Performed by	Kerwinn Corpuz

1 – 18 GHz Transmit at 5180 MHz (Low Channel)

Frequency	Raw	Cable Loss	AF	Level	Detector	Polarity	Height	Azimuth	Limit	Margin
MHz	dBuV/m	dB	dB	dBuV/m		H/V	cm	deg	dBuV/m	dB
10359.89	50.80	2.68	-12.75	40.72	Average	H	120	98	54.00	-13.28
17937.42	40.03	3.74	-3.17	40.60	Average	V	187	222	54.00	-13.40
15545.85	45.17	3.42	-12.50	36.08	Average	H	117	-8	54.00	-17.92

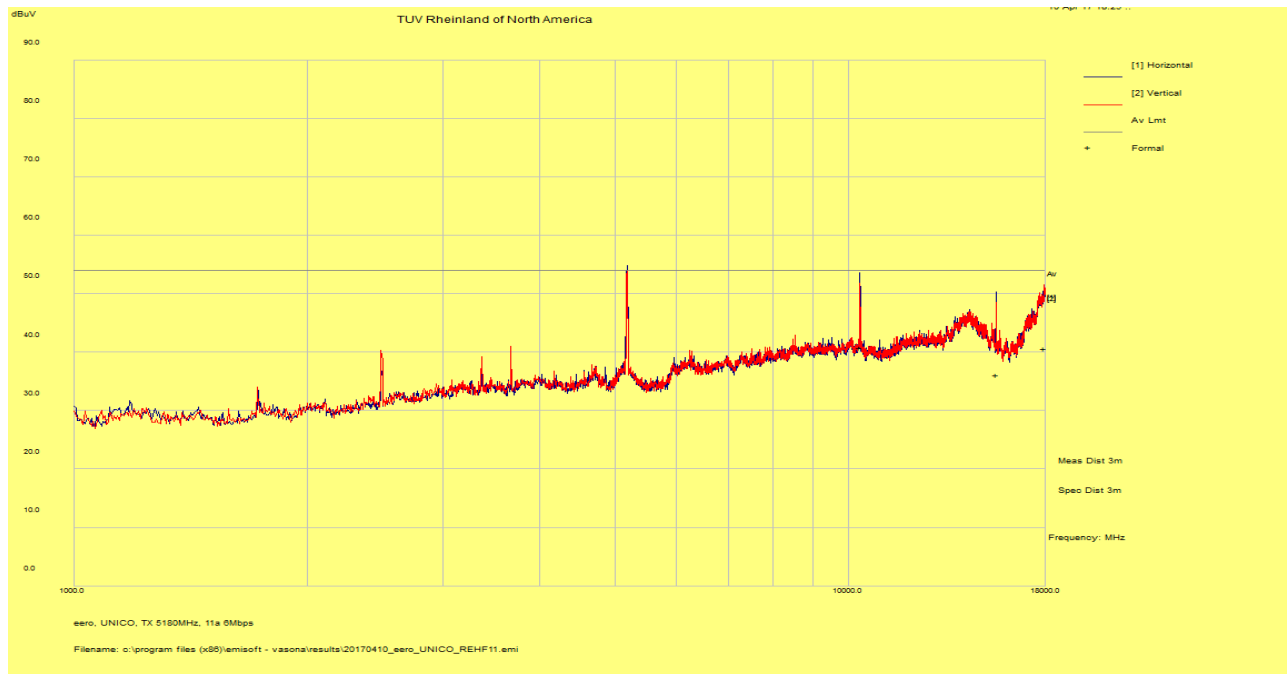

Spec Margin = E-Field AVG - Limit, E-Field AVG = FIM AVG+ Total CF ± Uncertainty

Total CF= AF+ Cable Loss AF= Antenna factor + Preamp

- Note:
1. Worst case was observed on 802.11a 6Mbps mode.
 2. Modes covered are HT20 and VHT20.
 3. To reduce complexity and bulkiness of the report Worst case Plots are placed in the report.
 4. Emission above the limit is the fundamental.

SOP 1 Radiated Emissions		Tracking # 31761399.001 Page 3 of 13	
EUT Name	Wi-Fi Router	Date	Apr 13, 2017
EUT Model	B010001 (USA), B010002 (IC)	Temp / Hum in	22° C / 42%rh
EUT Serial	SPE28JY	Temp / Hum out	N/A
EUT Config.	802.11a at 6Mbps / chain 0 & 1	Line AC / Freq	120 Vac / 60 Hz
Standard	CFR47 Part 15 Subpart C, RSS-247, RSS-GEN	RBW / VBW	1 MHz/ 3 MHz
Dist/Ant Used	3m - EMCO3115 / 1m - AHA-840	Performed by	Colton Aliff

18 – 40 GHz Transmit at 5180 MHz (Low Channel)

Frequency	Raw	Cable Loss	AF	Level	Detector	Polarity	Height	Azimuth	Limit	Margin
MHz	dBuV/m	dB	dB	dBuV/m		H/V	cm	deg	dBuV/m	dB
37930.95	43.38	10.05	-12.27	41.16	Average	V	133	104	54.00	-12.84
39913.84	47.90	10.91	-13.52	45.28	Average	V	144	202	54.00	-8.72

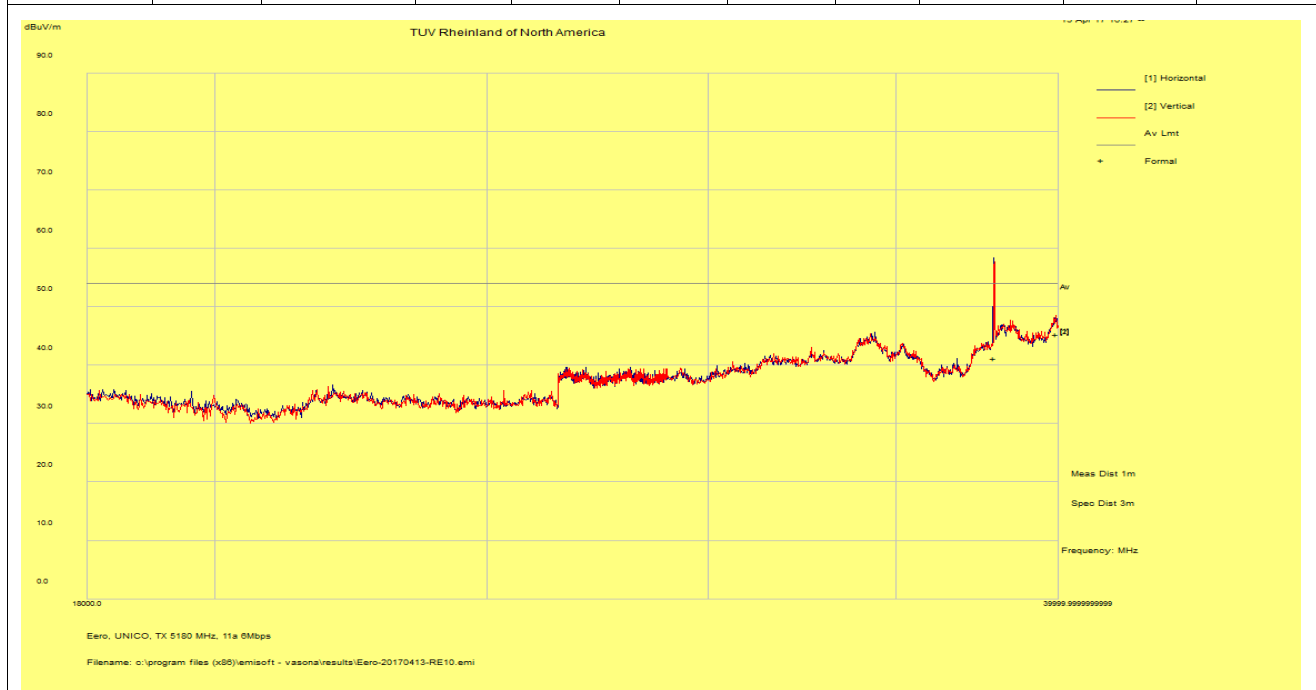

Spec Margin = E-Field AVG - Limit, E-Field AVG = FIM AVG+ Total CF ± Uncertainty

Total CF= AF+ Cable Loss AF= Antenna factor + Preamp

Note: 1. Worst case was observed on 802.11a 6Mbps mode.

2. Modes covered are HT20 and VHT20.

3. To reduce complexity and bulkiness of the report Worst case Plots are placed in the report.

SOP 1 Radiated Emissions

Tracking # 31761399.001 Page 4 of 13

EUT Name	Wi-Fi Router	Date	Apr 10, 2017
EUT Model	B010001 (USA), B010002 (IC)	Temp / Hum in	21° C / 40%rh
EUT Serial	SPE28JY	Temp / Hum out	N/A
EUT Config.	802.11a at 6Mbps / chain 0 & 1	Line AC / Freq	120 Vac / 60 Hz
Standard	CFR47 Part 15 Subpart C, RSS-247, RSS-GEN	RBW / VBW	1 MHz/ 3 MHz
Dist/Ant Used	3m - EMCO3115 / 1m - AHA-840	Performed by	Kerwinn Corpuz

1 – 18 GHz Transmit at 5240 MHz (High Channel)

Frequency	Raw	Cable Loss	AF	Level	Detector	Polarity	Height	Azimuth	Limit	Margin
MHz	dBuV/m	dB	dB	dBuV/m		H/V	cm	deg	dBuV/m	dB
17988.18	39.03	3.75	-2.92	39.86	Average	H	114	86	54.00	-14.14
10476.27	49.67	2.73	-12.73	39.66	Average	H	175	104	54.00	-14.34
15716.27	49.30	3.42	-12.79	39.93	Average	H	122	352	54.00	-14.07

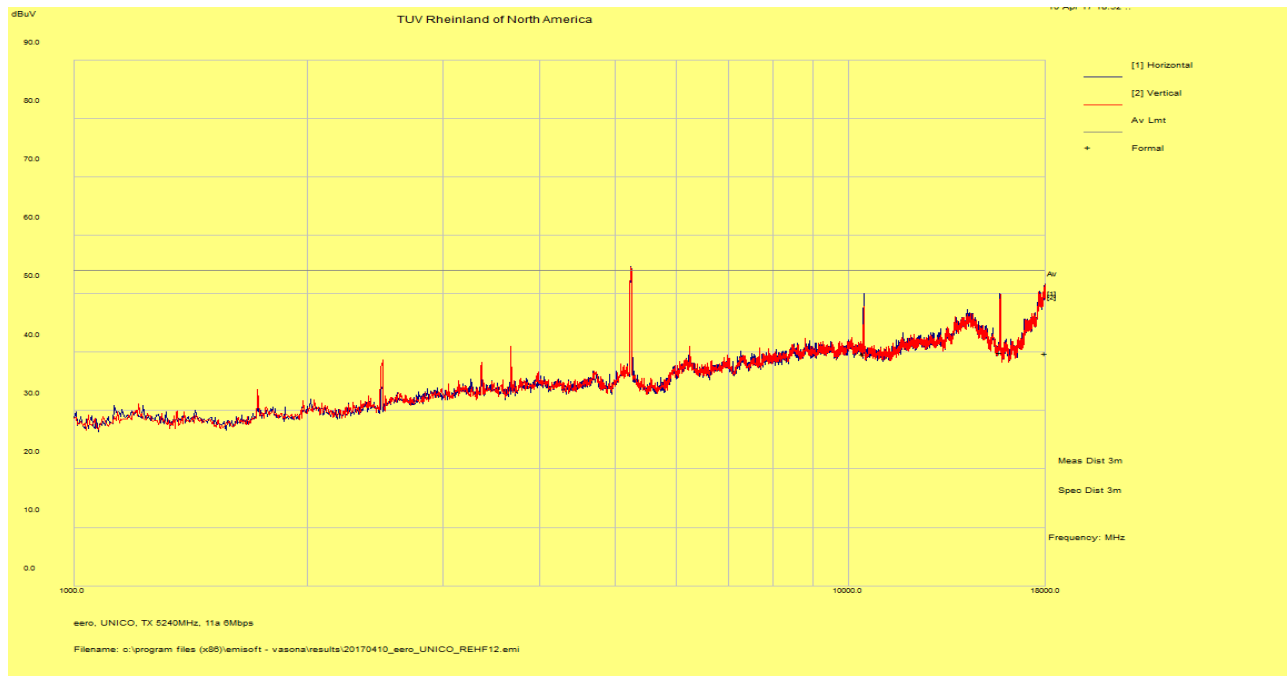

Spec Margin = E-Field AVG - Limit, E-Field AVG = FIM AVG+ Total CF ± Uncertainty

Total CF= AF+ Cable Loss AF= Antenna factor + Preamp

- Note:
1. Worst case was observed on 802.11a 6Mbps mode.
 2. Modes covered are HT20 and VHT20.
 3. To reduce complexity and bulkiness of the report Worst case Plots are placed in the report.
 4. Emission near the Spurious Limit is the Fundamental.

SOP 1 Radiated Emissions		Tracking # 31761399.001 Page 5 of 13	
EUT Name	Wi-Fi Router	Date	Apr 13, 2017
EUT Model	B010001 (USA), B010002 (IC)	Temp / Hum in	22° C / 42%rh
EUT Serial	SPE28JY	Temp / Hum out	N/A
EUT Config.	802.11a at 6Mbps / chain 0 & 1	Line AC / Freq	120 Vac / 60 Hz
Standard	CFR47 Part 15 Subpart C, RSS-247, RSS-GEN	RBW / VBW	1 MHz/ 3 MHz
Dist/Ant Used	3m - EMCO3115 / 1m – AHA-840	Performed by	Colton Aliff

18 – 40 GHz Transmit at 5240 MHz (High Channel)

Frequency	Raw	Cable Loss	AF	Level	Detector	Polarity	Height	Azimuth	Limit	Margin
MHz	dBuV/m	dB	dB	dBuV/m		H/V	cm	deg	dBuV/m	dB
37882.68	43.25	10.03	-12.41	40.86	Average	213	216	54.00	-13.14	213
39847.46	48.35	10.87	-13.54	45.68	Average	111	124	54.00	-8.32	111

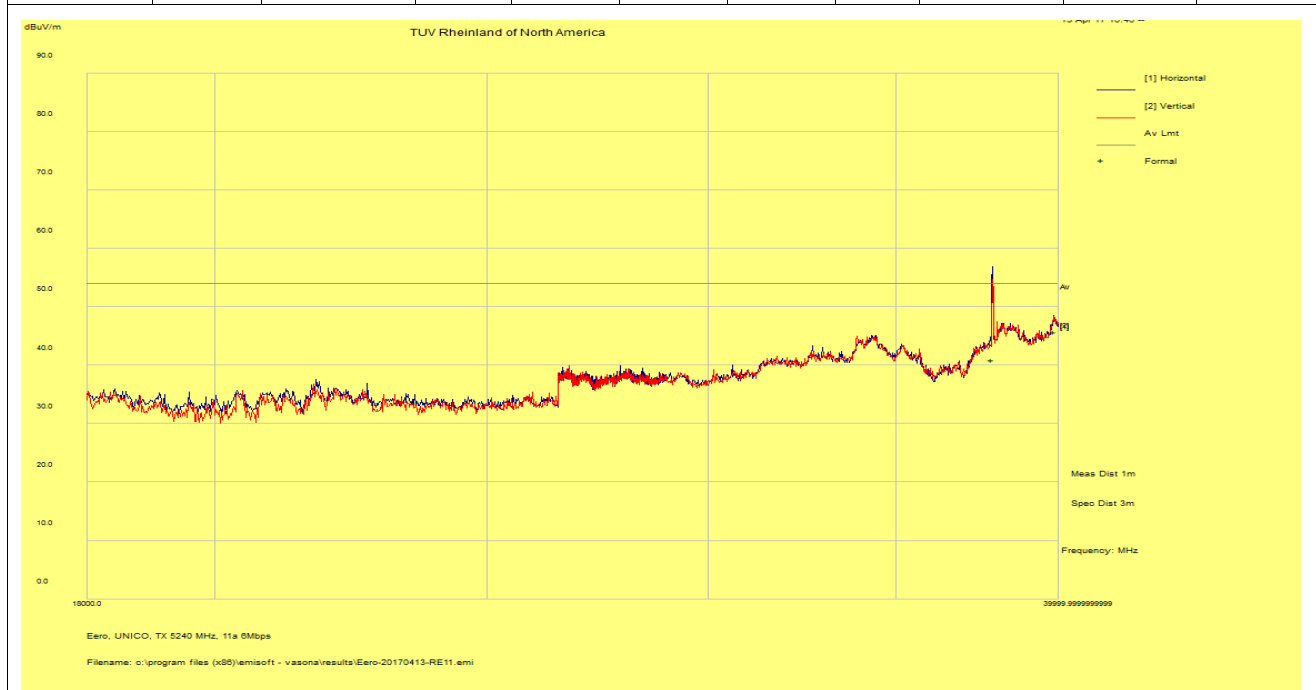

Spec Margin = E-Field AVG - Limit, E-Field AVG = FIM AVG+ Total CF ± Uncertainty

Total CF= AF+ Cable Loss AF= Antenna factor + Preamp

Note: 1. Worst case was observed on 802.11a 6Mbps mode.

2. Modes covered are HT20 and VHT20.

3. To reduce complexity and bulkiness of the report Worst case Plots are placed in the report.

SOP 1 Radiated Emissions		Tracking # 31761399.001 Page 6 of 13	
EUT Name	Wi-Fi Router	Date	Apr 11, 2017
EUT Model	B010001 (USA), B010002 (IC)	Temp / Hum in	22° C / 37%rh
EUT Serial	SPE28JY	Temp / Hum out	N/A
EUT Config.	802.11n at HT40 MCS0 / chain 0 & 1	Line AC / Freq	120 Vac / 60 Hz
Standard	CFR47 Part 15 Subpart C, RSS-247, RSS-GEN	RBW / VBW	120 kHz/ 300 kHz
Dist/Ant Used	3m / JB3	Performed by	Kerwinn Corpuz

30 MHz – 1 GHz Transmit at 5230 MHz

Frequency	Raw	Cable Loss	AF	Level	Detector	Polarity	Height	Azimuth	Limit	Margin
MHz	dBuV/m	dB	dB	dBuV/m		H/V	cm	deg	dBuV/m	dB
39.49	50.21	2.64	-17.69	35.17	QP	V	118	30	40.00	-4.83
46.76	53.35	2.71	-22.31	33.75	QP	V	121	324	40.00	-6.25
78.87	56.02	2.94	-24.40	34.57	QP	V	108	16	40.00	-5.44
93.55	47.48	3.03	-24.02	26.48	QP	V	123	288	43.50	-17.02
143.44	44.50	3.29	-19.30	28.48	QP	V	104	254	43.50	-15.02
172.93	46.53	3.43	-20.42	29.53	QP	V	121	108	43.50	-13.97

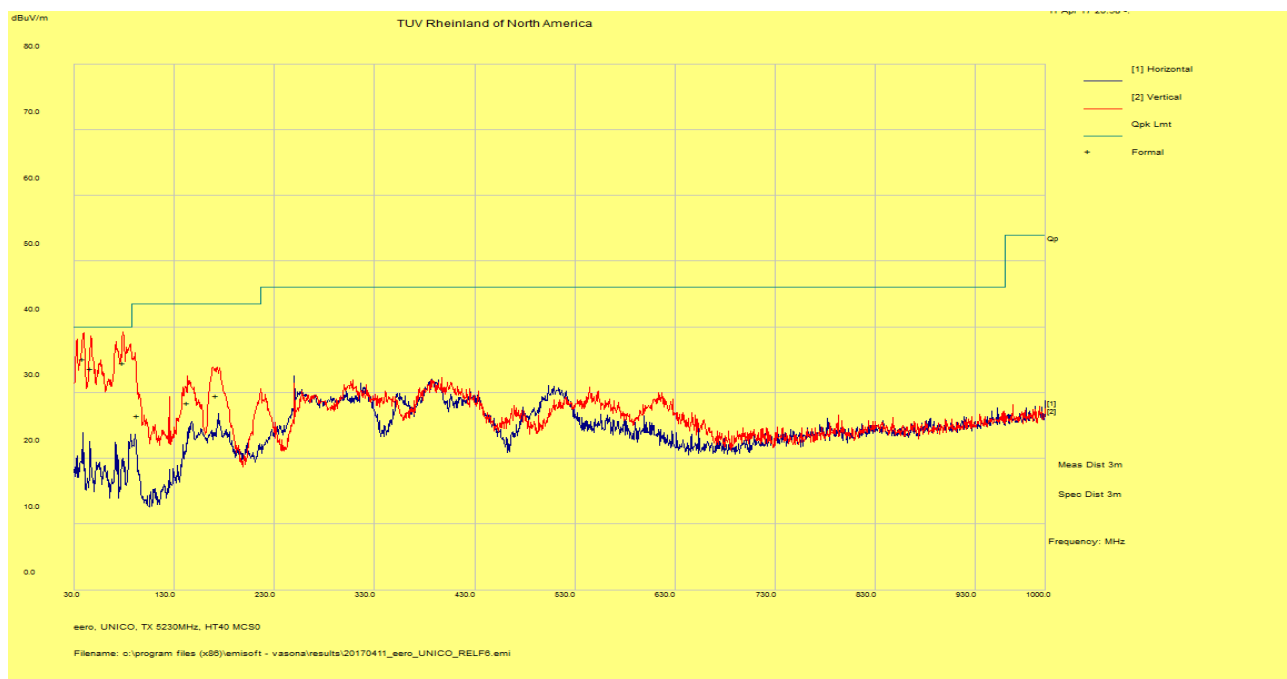

Spec Margin = E-Field QP - Limit, E-Field QP = FIM QP+ Total CF ± Uncertainty

Total CF= AF+ Cable Loss AF= Antenna factor + Preamp

- Note:
1. Worst case was observed on Mid channel of 802.11n HT40 MCS0 mode for 40MHz channel BW.
 2. Mode tested are 802.11a, HT20, VHT20, HT40, VHT40 & VHT80 (low, mid & high channel).
 3. No significant emission was observed below 30MHz.
 4. To reduce complexity and bulkiness of the report Worst case Plots are placed in the report.

SOP 1 Radiated Emissions		Tracking # 31761399.001 Page 7 of 13	
EUT Name	Wi-Fi Router	Date	Apr 12, 2017
EUT Model	B010001 (USA), B010002 (IC)	Temp / Hum in	22° C / 40%rh
EUT Serial	SPE28JY	Temp / Hum out	N/A
EUT Config.	802.11n at HT40 MCS0 / chain 0 & 1	Line AC / Freq	120 Vac / 60 Hz
Standard	CFR47 Part 15 Subpart C, RSS-247, RSS-GEN	RBW / VBW	1 MHz/ 3 MHz
Dist/Ant Used	3m - EMCO3115 / 1m - AHA-840	Performed by	Colton Aliff

1 – 18 GHz Transmit at 5190 MHz (Low Channel)

Frequency	Raw	Cable Loss	AF	Level	Detector	Polarity	Height	Azimuth	Limit	Margin
MHz	dBuV/m	dB	dB	dBuV/m		H/V	cm	deg	dBuV/m	dB
17952.50	40.15	3.76	-3.09	40.81	Average	H	190	312	54.00	-13.19
14275.53	40.38	3.12	-8.24	35.26	Average	V	240	358	54.00	-18.75

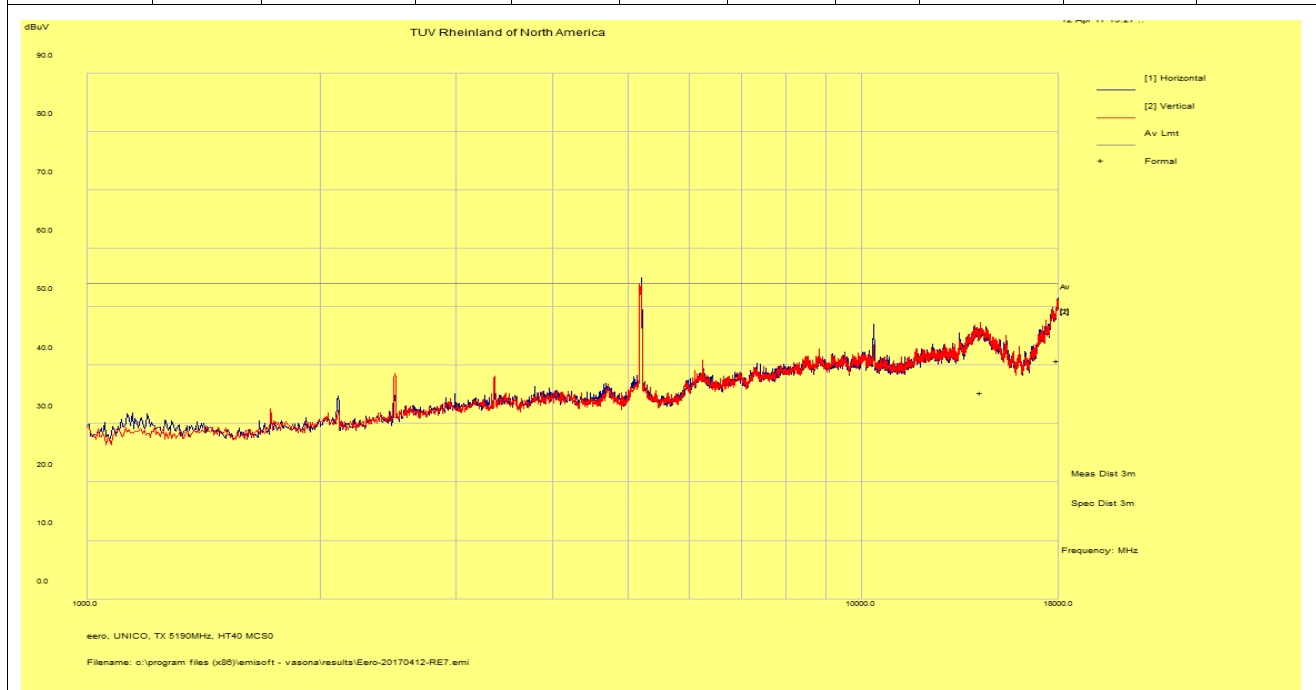

Spec Margin = E-Field AVG - Limit, E-Field AVG = FIM AVG+ Total CF ± Uncertainty

Total CF= AF+ Cable Loss AF= Antenna factor + Preamp

Note: 1. Worst case was observed on HT40 MCS0 mode.

2. Mode covered is VHT40.

3. To reduce complexity and bulkiness of the report Worst case Plots are placed in the report.

4. Emission above the Spurious Limit is the Fundamental.

SOP 1 Radiated Emissions		Tracking # 31761399.001 Page 8 of 13	
EUT Name	Wi-Fi Router	Date	Apr 13, 2017
EUT Model	B010001 (USA), B010002 (IC)	Temp / Hum in	22° C / 42%rh
EUT Serial	SPE28JY	Temp / Hum out	N/A
EUT Config.	802.11n at HT40 MCS0 / chain 0 & 1	Line AC / Freq	120 Vac / 60 Hz
Standard	CFR47 Part 15 Subpart C, RSS-247, RSS-GEN	RBW / VBW	1 MHz/ 3 MHz
Dist/Ant Used	3m - EMCO3115 / 1m - AHA-840	Performed by	Colton Aliff

18 – 40 GHz Transmit at 5190 MHz (Low Channel)

Frequency	Raw	Cable Loss	AF	Level	Detector	Polarity	Height	Azimuth	Limit	Margin
MHz	dBuV/m	dB	dB	dBuV/m		H/V	cm	deg	dBuV/m	dB
37884.75	43.27	10.03	-12.41	40.89	Average	V	138	142	54.00	-13.11
39870.03	48.32	10.88	-13.53	45.67	Average	H	146	40	54.00	-8.33

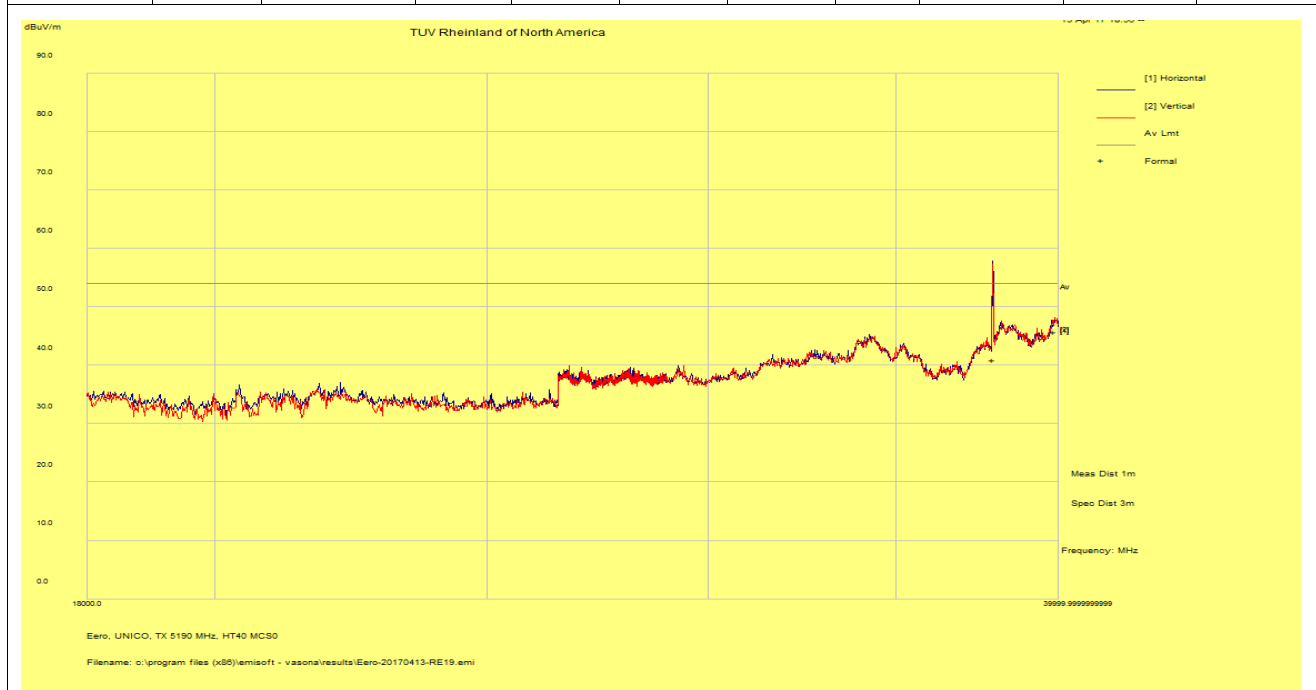

Spec Margin = E-Field AVG - Limit, E-Field AVG = FIM AVG+ Total CF ± Uncertainty

Total CF= AF+ Cable Loss AF= Antenna factor + Preamp

Note: 1. Worst case was observed on HT40 MCS0 mode.

2. Mode covered is VHT40.

3. To reduce complexity and bulkiness of the report Worst case Plots are placed in the report.

SOP 1 Radiated Emissions				Tracking # 31761399.001 Page 9 of 13			
EUT Name	Wi-Fi Router			Date	Apr 12, 2017		
EUT Model	B010001 (USA), B010002 (IC)			Temp / Hum in	22° C / 40%rh		
EUT Serial	SPE28JY			Temp / Hum out	N/A		
EUT Config.	802.11n at HT40 MCS0 / chain 0 & 1			Line AC / Freq	120 Vac / 60 Hz		
Standard	CFR47 Part 15 Subpart C, RSS-247, RSS-GEN			RBW / VBW	1 MHz/ 3 MHz		
Dist/Ant Used	3m - EMCO3115 / 1m - AHA-840			Performed by	Colton Aliff		

1 – 18 GHz Transmit at 5230 MHz (High Channel)

Frequency	Raw	Cable Loss	AF	Level	Detector	Polarity	Height	Azimuth	Limit	Margin
MHz	dBuV/m	dB	dB	dBuV/m		H/V	cm	deg	dBuV/m	dB
17930.24	40.12	3.73	-3.21	40.64	Average	V	143	333	54.00	-13.36
14083.96	40.48	3.22	-8.58	35.12	Average	V	176	20	54.00	-18.88

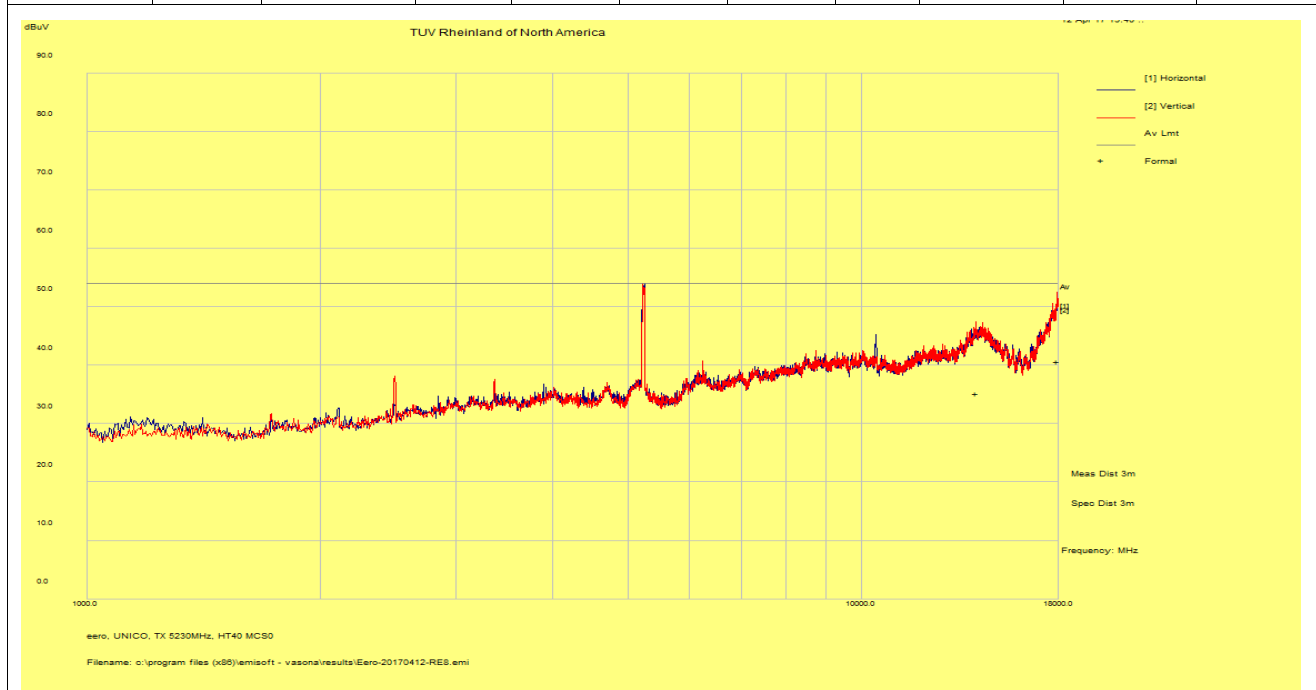

Spec Margin = E-Field AVG - Limit, E-Field AVG = FIM AVG+ Total CF ± Uncertainty

Total CF= AF+ Cable Loss AF= Antenna factor + Preamp

Note: 1. Worst case was observed on HT40 MCS0 mode.

2. Mode covered is VHT40.

3. To reduce complexity and bulkiness of the report Worst case Plots are placed in the report.

4. Emission above the Spurious Limit is the Fundamental.

SOP 1 Radiated Emissions				Tracking # 31761399.001 Page 10 of 13			
EUT Name	Wi-Fi Router			Date	Apr 13, 2017		
EUT Model	B010001 (USA), B010002 (IC)			Temp / Hum in	22° C / 42%rh		
EUT Serial	SPE28JY			Temp / Hum out	N/A		
EUT Config.	802.11n at HT40 MCS0 / chain 0 & 1			Line AC / Freq	120 Vac / 60 Hz		
Standard	CFR47 Part 15 Subpart C, RSS-247, RSS-GEN			RBW / VBW	1 MHz/ 3 MHz		
Dist/Ant Used	3m - EMCO3115 / 1m - AHA-840			Performed by	Colton Aliff		

18 – 40 GHz Transmit at 5230 MHz (High Channel)

Frequency	Raw	Cable Loss	AF	Level	Detector	Polarity	Height	Azimuth	Limit	Margin
MHz	dBuV/m	dB	dB	dBuV/m		H/V	cm	deg	dBuV/m	dB
37908.18	43.18	10.04	-12.34	40.87	Average	V	205	114	54.00	-13.13
39937.32	47.58	10.93	-13.52	44.99	Average	H	167	316	54.00	-9.01

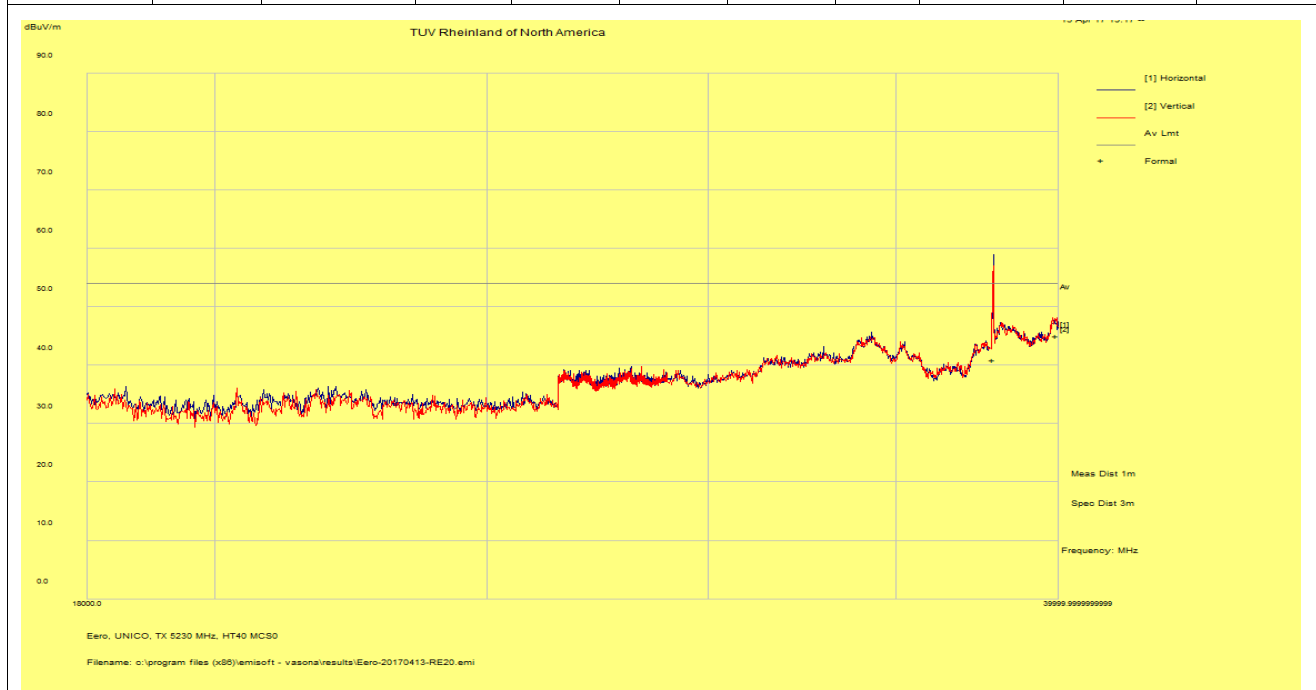

Spec Margin = E-Field AVG - Limit, E-Field AVG = FIM AVG+ Total CF ± Uncertainty

Total CF= AF+ Cable Loss AF= Antenna factor + Preamp

Note: 1. Worst case was observed on HT40 MCS0 mode.

2. Mode covered is VHT40.

3. To reduce complexity and bulkiness of the report Worst case Plots are placed in the report.

SOP 1 Radiated Emissions

Tracking # 31761399.001 Page 11 of 13

EUT Name	Wi-Fi Router	Date	Apr 11, 2017
EUT Model	B010001 (USA), B010002 (IC)	Temp / Hum in	22° C / 37%rh
EUT Serial	SPE28JY	Temp / Hum out	N/A
EUT Config.	802.11ac at VHT80 MCS0 / chain 0 & 1	Line AC / Freq	120 Vac / 60 Hz
Standard	CFR47 Part 15 Subpart C, RSS-247, RSS-GEN	RBW / VBW	120 kHz/ 300 kHz
Dist/Ant Used	3m / JB3	Performed by	Kerwinn Corpuz

30 MHz – 1 GHz Transmit at 5210 MHz

Frequency	Raw	Cable Loss	AF	Level	Detector	Polarity	Height	Azimuth	Limit	Margin
MHz	dBuV/m	dB	dB	dBuV/m		H/V	cm	deg	dBuV/m	dB
39.01	48.54	2.64	-17.35	33.84	QP	V	147	278	40.00	-6.16
47.05	52.27	2.71	-22.46	32.53	QP	V	142	106	40.00	-7.48
85.31	55.03	2.97	-24.90	33.10	QP	V	148	168	40.00	-6.90
92.44	48.70	3.02	-24.31	27.41	QP	V	116	266	43.50	-16.09
144.97	42.66	3.30	-19.45	26.52	QP	V	131	-8	43.50	-16.98
168.44	47.40	3.40	-20.07	30.73	QP	V	109	144	43.50	-12.77

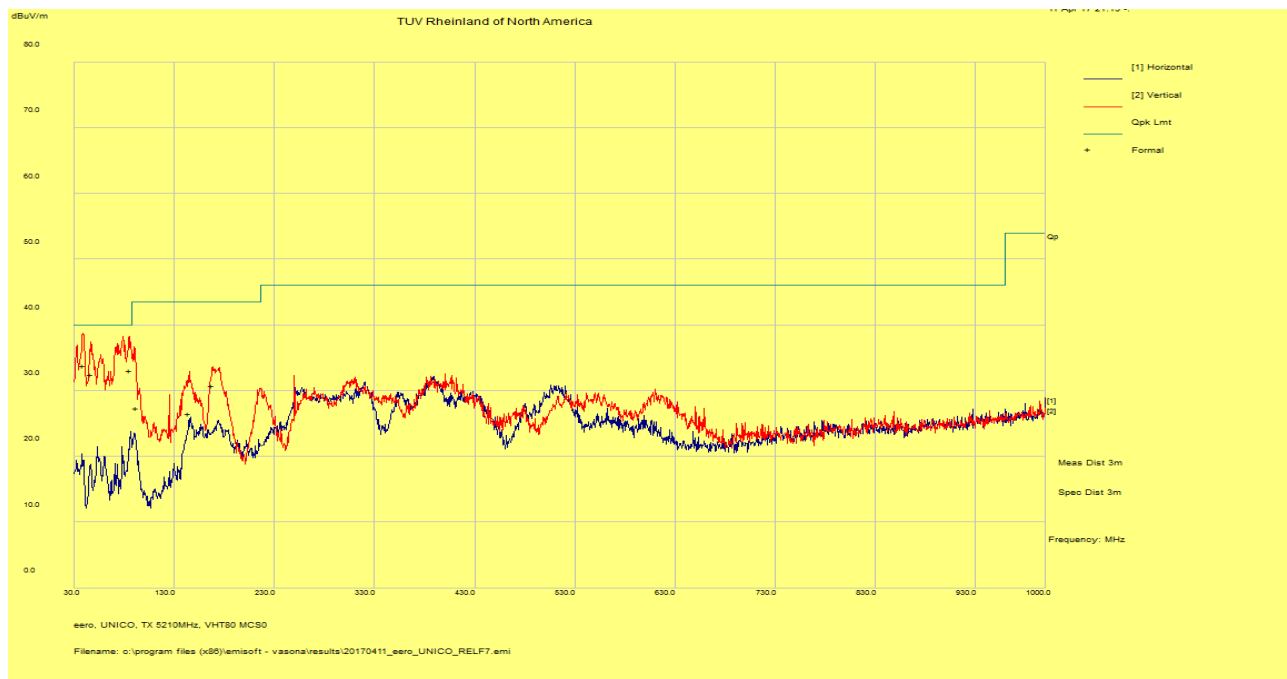

Spec Margin = E-Field QP - Limit, E-Field QP = FIM QP+ Total CF ± Uncertainty

Total CF= AF+ Cable Loss AF= Antenna factor + Preamp

- Note:
1. Worst case was observed on Mid channel of 802.11ac VHT80 MCS0 mode for 80MHz channel BW.
 2. Mode tested are 802.11a, HT20, VHT20, HT40, VHT40 & VHT80 (low, mid & high channel).
 3. No significant emission was observed below 30MHz.
 4. To reduce complexity and bulkiness of the report Worst case Plots are placed in the report.

SOP 1 Radiated Emissions				Tracking # 31761399.001 Page 12 of 13			
EUT Name	Wi-Fi Router			Date	Apr 12, 2017		
EUT Model	B010001 (USA), B010002 (IC)			Temp / Hum in	22° C / 40%rh		
EUT Serial	SPE28JY			Temp / Hum out	N/A		
EUT Config.	802.11n at VHT80 MCS0 / chain 0 & 1			Line AC / Freq	120 Vac / 60 Hz		
Standard	CFR47 Part 15 Subpart C, RSS-247, RSS-GEN			RBW / VBW	1 MHz/ 3 MHz		
Dist/Ant Used	3m - EMCO3115 / 1m - AHA-840			Performed by	Colton Aliff		

1 – 18 GHz Transmit at 5210 MHz (Mid Channel)

Frequency	Raw	Cable Loss	AF	Level	Detector	Polarity	Height	Azimuth	Limit	Margin
MHz	dBuV/m	dB	dB	dBuV/m		H/V	cm	deg	dBuV/m	dB
17929.37	40.06	3.73	-3.21	40.58	Average	H	117	264	54.00	-13.43
14355.57	40.59	3.20	-8.31	35.47	Average	H	192	228	54.00	-18.53

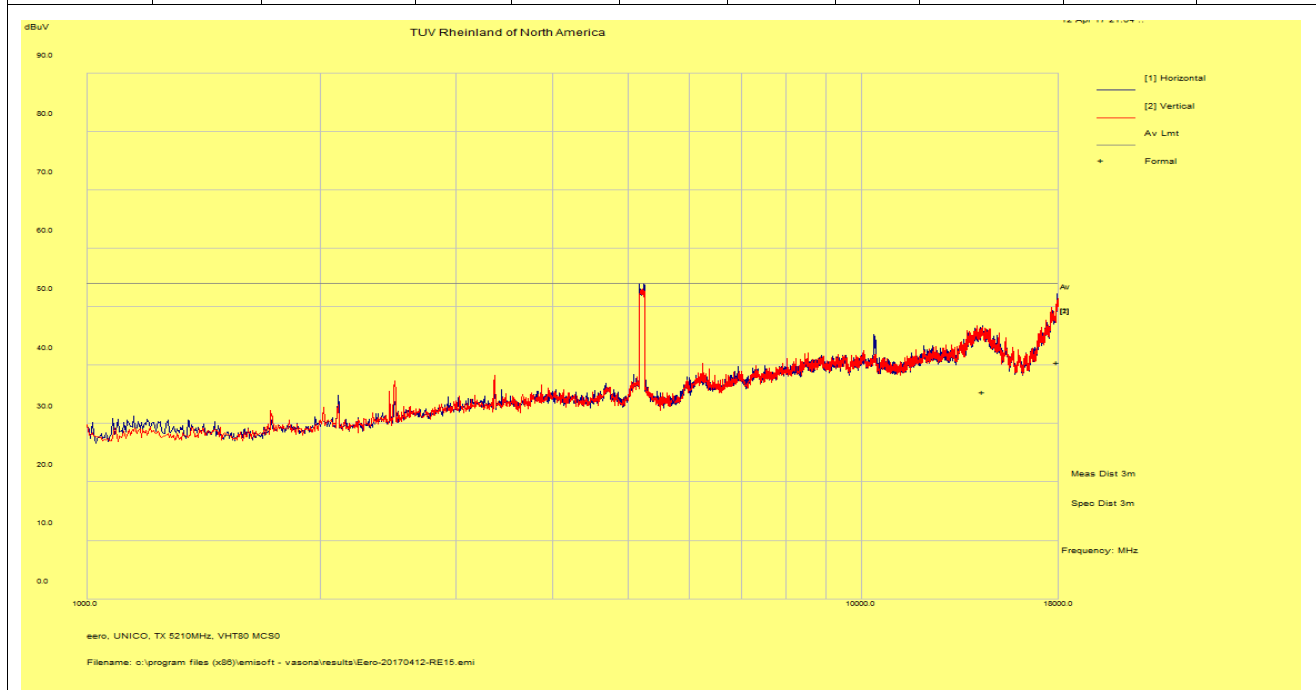

Spec Margin = E-Field AVG - Limit, E-Field AVG = FIM AVG+ Total CF ± Uncertainty

Total CF= AF+ Cable Loss AF= Antenna factor + Preamp

- Note: 1. To reduce complexity and bulkiness of the report Worst case Plots are placed in the report.
 2. Emission above the Spurious Limit is the Fundamental.

SOP 1 Radiated Emissions

Tracking # 31761399.001 Page 13 of 13

EUT Name	Wi-Fi Router	Date	Apr 13, 2017
EUT Model	B010001 (USA), B010002 (IC)	Temp / Hum in	22° C / 42%rh
EUT Serial	SPE28JY	Temp / Hum out	N/A
EUT Config.	802.11n at VHT80 MCS0 / chain 0 & 1	Line AC / Freq	120 Vac / 60 Hz
Standard	CFR47 Part 15 Subpart C, RSS-247, RSS-GEN	RBW / VBW	1 MHz/ 3 MHz
Dist/Ant Used	3m - EMCO3115 / 1m – AHA-840	Performed by	Colton Aliff

18 – 40 GHz Transmit at 5210 MHz (Mid Channel)

Frequency	Raw	Cable Loss	AF	Level	Detector	Polarity	Height	Azimuth	Limit	Margin
MHz	dBuV/m	dB	dB	dBuV/m		H/V	cm	deg	dBuV/m	dB
37883.40	42.42	10.03	-12.41	40.03	Average	V	109	122	54.00	-13.97

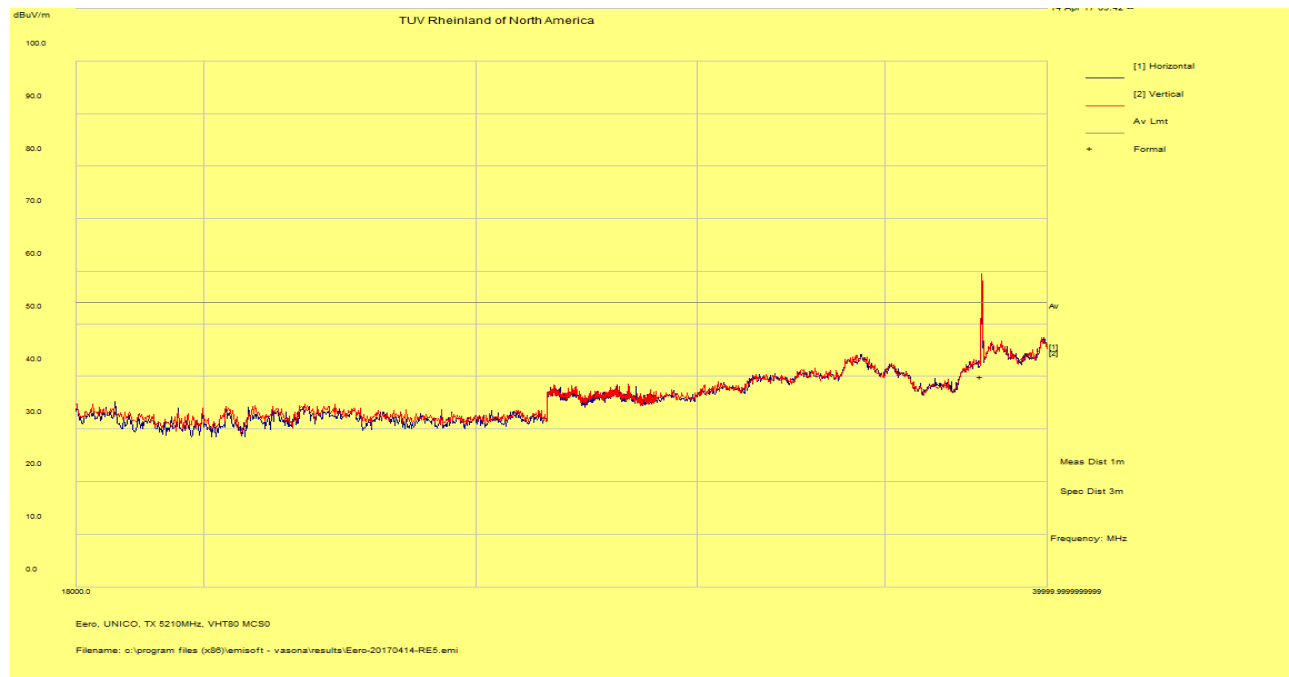

Spec Margin = E-Field AVG - Limit, E-Field AVG = FIM AVG+ Total CF ± Uncertainty
 Total CF= AF+ Cable Loss AF= Antenna factor + Preamp

Note: To reduce complexity and bulkiness of the report Worst case Plots are placed in the report.

4.6 AC Conducted Emissions

Testing was performed in accordance with ANSI C63.4: 2014. These test methods are listed under the laboratory's A2LA Scope of Accreditation.

This test measures the levels emanating from the EUT's AC input port, thus evaluating the potential for the EUT to cause radio frequency interference to other electronic devices.

The AC conducted emissions of equipment under test shall not exceed the values in CFR47 Part 15.207: 2016 and RSS GEN: 2014.

4.6.1 Test Methodology

A test program that controls instrumentation and data logging was used to automate the AC Power Line Conducted emission test procedure. The frequency range of interest was divided into sub-ranges such as to yield a frequency resolution of 9 kHz. Each phase and neutral of the AC power line were measured with respect to ground. Measurements were performed using a set of 50µH / 50Ω LISNs.

Testing is performed in Lab 5. The setup photographs clearly identify which site was used. The vertical ground plane used in the semi-anechoic chamber is a 2m x 2m solid aluminum frame and panel, and it is bonded to the horizontal ground plane.

In the case of tabletop equipment, the EUT is placed on a 1.0m x 1.5m non-conductive table 80cm above the ground plane and 40cm from a vertical ground reference plane. The rear of the EUT was positioned flush with the backside of the table and directly over the LISNs. The power and I/O cables were routed over the edge of the table and bundled approximately 40cm from the ground plane. Support equipment was powered from a separate LISN.

4.6.1.1 Deviations

There were no deviations from this test methodology.

4.6.2 Test Results

As originally tested, the EUT was found to be compliant to the requirements of the test standard(s).

Table 24: AC Conducted Emissions – Test Results

Test Conditions: Conducted Measurement at Normal Conditions only		
Antenna Type: FPCB	Power Level: See Test Plan	
AC Power: 120 Vac/60 Hz	Configuration: Tabletop	
Ambient Temperature: 22° C	Relative Humidity: 41% RH	
Configuration	Frequency Range	Test Result
Line 1 (Hot)	0.15 to 30 MHz	Pass
Line 2 (Neutral)	0.15 to 30 MHz	Pass

SOP 2 Conducted Emissions						Tracking # 31761399.001 Page 1 of 4			
EUT Name		Wi-Fi Router				Date		Apr 14, 2017	
EUT Model		B010001 (USA), B010002 (IC)				Temp / Hum in		22° C / 41% rh	
EUT Serial		SPE28JY				Temp / Hum out		N/A	
EUT Config.		TX mode / chain 0 & 1				Line AC / Freq		120Vac / 60Hz	
Standard		CFR47 Part 15.207 and RSS Gen				RBW / VBW		9 kHz / 30 kHz	
Lab/LISN		Lab #5 /Com-Power, Line 1				Performed by		Colton Aliff	
Frequency	Raw	Limiters	Ins. Loss	Level	Detector	Line	Limit	Margin	Result
MHz	dBuV	dB	dB	dBuV		Line	dBuV	dB	
1.253	32.05	9.87	0.03	41.95	QP	Live	56.00	-14.05	Pass
1.253	20.67	9.87	0.03	30.57	Ave	Live	46.00	-15.43	Pass
1.631	29.53	9.88	0.03	39.44	QP	Live	56.00	-16.56	Pass
1.631	18.83	9.88	0.03	28.74	Ave	Live	46.00	-17.26	Pass
2.947	32.48	9.90	0.03	42.41	QP	Live	56.00	-13.59	Pass
2.947	22.90	9.90	0.03	32.83	Ave	Live	46.00	-13.17	Pass
3.238	32.02	9.90	0.03	41.95	QP	Live	56.00	-14.05	Pass
3.238	22.40	9.90	0.03	32.33	Ave	Live	46.00	-13.67	Pass
3.627	29.83	9.91	0.03	39.77	QP	Live	56.00	-16.23	Pass
3.627	19.69	9.91	0.03	29.63	Ave	Live	46.00	-16.37	Pass
6.839	32.07	9.94	0.03	42.04	QP	Live	60.00	-17.96	Pass
6.839	22.42	9.94	0.03	32.39	Ave	Live	50.00	-17.61	Pass
Spec Margin = QP./Ave. - Limit, ± Uncertainty									
Combined Standard Uncertainty $u_c(y) = \pm 1.2$ dB Expanded Uncertainty $U = k u_c(y)$ $k = 2$ for 95% confidence									
Notes: The EUT was set horizontally on the table top and transmitted at 5180 MHz in 802.11a at 6Mbps									

SOP 2 Conducted Emissions

Tracking # 31761399.001 Page 2 of 4

EUT Name	Wi-Fi Router	Date	Apr 14, 2017
EUT Model	B010001 (USA), B010002 (IC)	Temp / Hum in	22° C / 41% rh
EUT Serial	SPE28JY	Temp / Hum out	N/A
EUT Config.	TX mode / chain 0 & 1	Line AC	120Vac / 60Hz
Standard	CFR47 Part 15.207 and RSS Gen	RBW / VBW	9 kHz / 30 kHz
Lab/LISN	Lab #5 /Com-Power, Line 1	Performed by	Colton Aliff

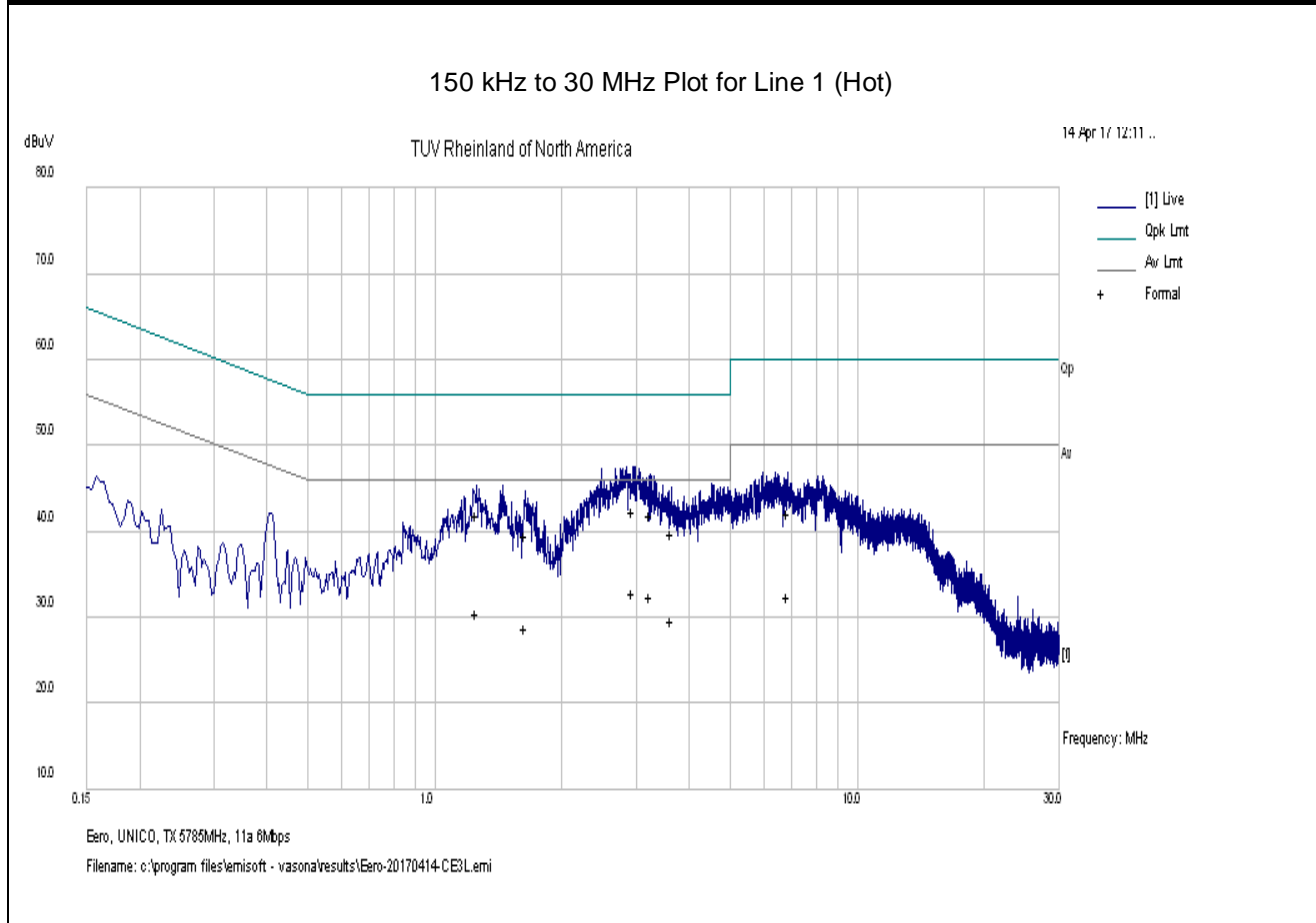

Note: Met FCC Class B limit.

SOP 2 Conducted Emissions						Tracking # 31761399.001 Page 3 of 4			
EUT Name		Wi-Fi Router				Date		Apr 14, 2017	
EUT Model		B010001 (USA), B010002 (IC)				Temp / Hum in		22° C / 41% rh	
EUT Serial		SPE28JY				Temp / Hum out		N/A	
EUT Config.		TX mode / chain 0 & 1				Line AC / Freq		120Vac / 60Hz	
Standard		CFR47 Part 15.207 and RSS Gen				RBW / VBW		9 kHz / 30 kHz	
Lab/LISN		Lab #5 /Com-Power, Line 2				Performed by		Colton Aliff	
Frequency	Raw	Limiter	Ins. Loss	Level	Detector	Line	Limit	Margin	Result
MHz	dBuV	dB	dB	dBuV		Line	dBuV	dB	
1.496	29.11	9.88	0.03	39.01	QP	Neutral	56.00	-16.99	Pass
1.496	19.58	9.88	0.03	29.49	Ave	Neutral	46.00	-16.51	Pass
1.664	30.05	9.88	0.03	39.96	QP	Neutral	56.00	-16.04	Pass
1.664	21.08	9.88	0.03	30.98	Ave	Neutral	46.00	-15.02	Pass
2.371	31.21	9.89	0.03	41.12	QP	Neutral	56.00	-14.88	Pass
2.371	21.38	9.89	0.03	31.30	Ave	Neutral	46.00	-14.70	Pass
2.801	33.43	9.90	0.03	43.36	QP	Neutral	56.00	-12.64	Pass
2.801	22.16	9.90	0.03	32.08	Ave	Neutral	46.00	-13.92	Pass
3.242	32.19	9.90	0.03	42.12	QP	Neutral	56.00	-13.88	Pass
3.242	21.37	9.90	0.03	31.30	Ave	Neutral	46.00	-14.70	Pass
4.827	31.00	9.92	0.03	40.95	QP	Neutral	56.00	-15.05	Pass
4.827	20.12	9.92	0.03	30.07	Ave	Neutral	46.00	-15.93	Pass
Spec Margin = QP./Ave. - Limit, ± Uncertainty									
Combined Standard Uncertainty $u_c(y) = \pm 1.2$ dB Expanded Uncertainty $U = k u_c(y)$ $k = 2$ for 95% confidence									
Notes: The EUT was set horizontally on the table top and transmitted at 5180 MHz in 802.11a at 6Mbps									

SOP 2 Conducted Emissions

Tracking # 31761399.001 Page 4 of 4

EUT Name	Wi-Fi Router	Date	Apr 14, 2017
EUT Model	B010001 (USA), B010002 (IC)	Temp / Hum in	22° C / 41% rh
EUT Serial	SPE28JY	Temp / Hum out	N/A
EUT Config.	TX mode / chain 0 & 1	Line AC	120Vac / 60Hz
Standard	CFR47 Part 15.207 and RSS Gen	RBW / VBW	9 kHz / 30 kHz
Lab/LISN	Lab #5 /Com-Power, Line 2	Performed by	Colton Aliff

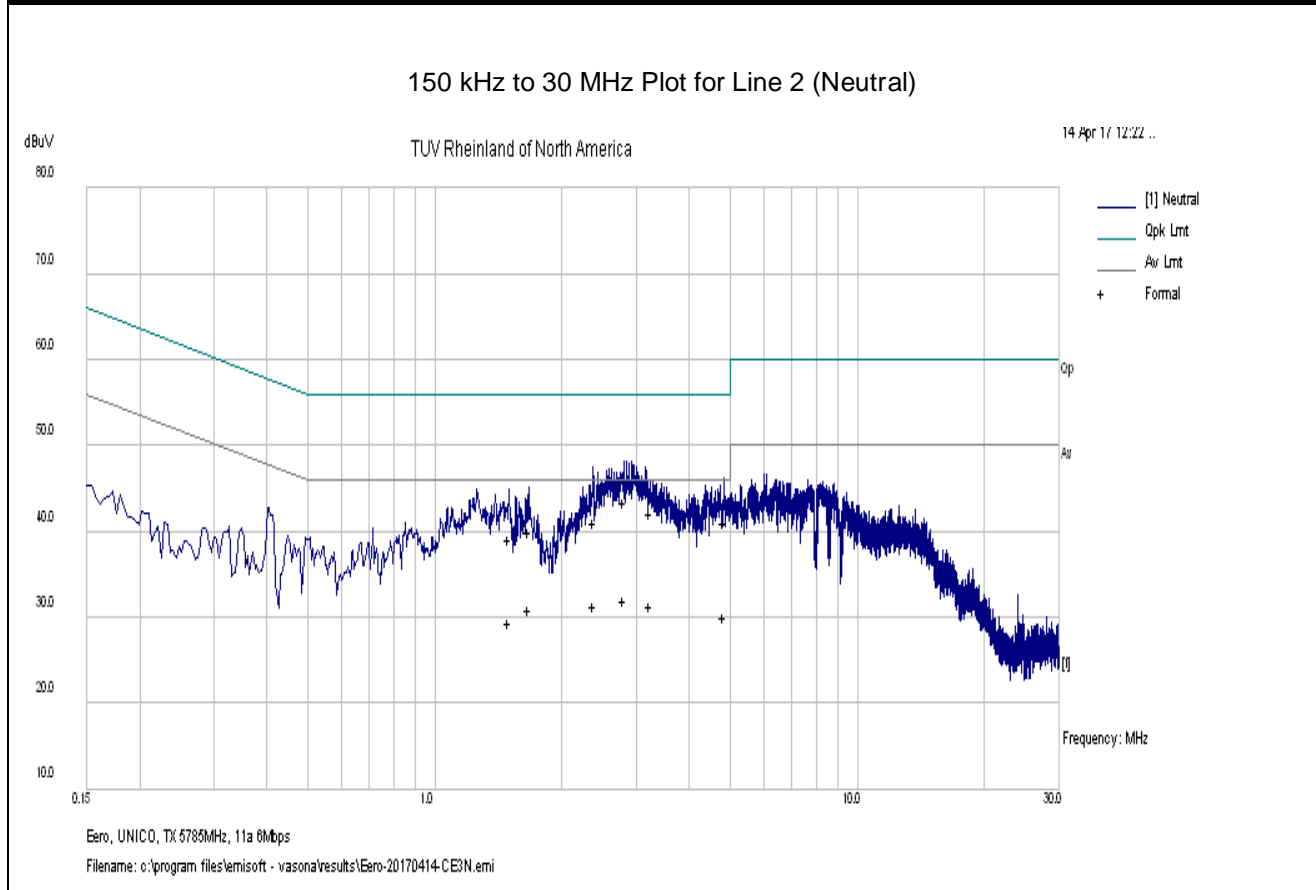

Note: Met FCC Class B Limit.

4.7 Frequency Stability

In accordance with 47 CFR Part 15.407(g) and RSS GEN Sect. 6.11 the frequency stability of U-NII devices must be such that an emission is maintained within the band of operation under all conditions of normal operation as specified in the user's manual. The Manufacturer calls out operating temperature ranges of +0° to +35° C

4.7.1 Test Methodology

The manufacturer of the equipment is responsible for ensuring that the frequency stability is such that emissions are always maintained within the band of operation under all conditions. This test performs according to ANSI C63.10-2013 Section 6.8

4.7.2 Manufacturer Declaration

The frequency stability of the reference oscillator sets the frequency stability of the RF transceiver signals. Therefore all of the RF signal should have ± 20 ppm stability.

This stability accounts for room temp tolerance of the crystal oscillator circuit, frequency variation across temperature, and crystal ageing.

Worst case:

5.180 GHz - ± 20 ppm/104 kHz

± 20 ppm at 5.18 GHz translates to a maximum frequency shift of ± 104 kHz. As the edge of the channels are at least one MHz from either of the band edges, ± 103 kHz is more than sufficient to guarantee that the intentional emission will remain in the band over the entire operating range of the radio.

4.7.3 Limit

CFR47 Part 15.407(g) and RSS GEN Sect. 6.11 - Manufacturers of U-NII devices are responsible for ensuring frequency stability such that an emission is maintained within the band of operation under all conditions of normal operation as specified in the user's manual.

4.7.4 Test results:

As originally tested, the EUT was found to be compliant to the requirements of the test standard(s) since the maximum frequency drift was 9.92 ppm.

Table 25: Frequency Stability – Test Results

Temperature	Time	PPM
0° C	Start	8.41
	2 Min.	9.92
	5 Min	9.42
	10 min	9.06
10° C	Start	9.06
	2 Min.	8.70
	5 Min	7.62
	10 min	7.62
20° C	Start	7.25
	2 Min.	6.17
	5 Min	5.80
	10 min	5.08
30° C	Start	0.73
	2 Min.	0.38
	5 Min	0.38
	10 min	2.18
40° C	Start	1.81
	2 Min.	0.01
	5 Min	-0.35
	10 min	-0.45
50° C	Start	-1.19
	2 Min.	0.63
	5 Min	0.26
	10 min	0.26

Note: All frequency drifts were less than ± 20 ppm. The worst frequency drift was 9.92 ppm

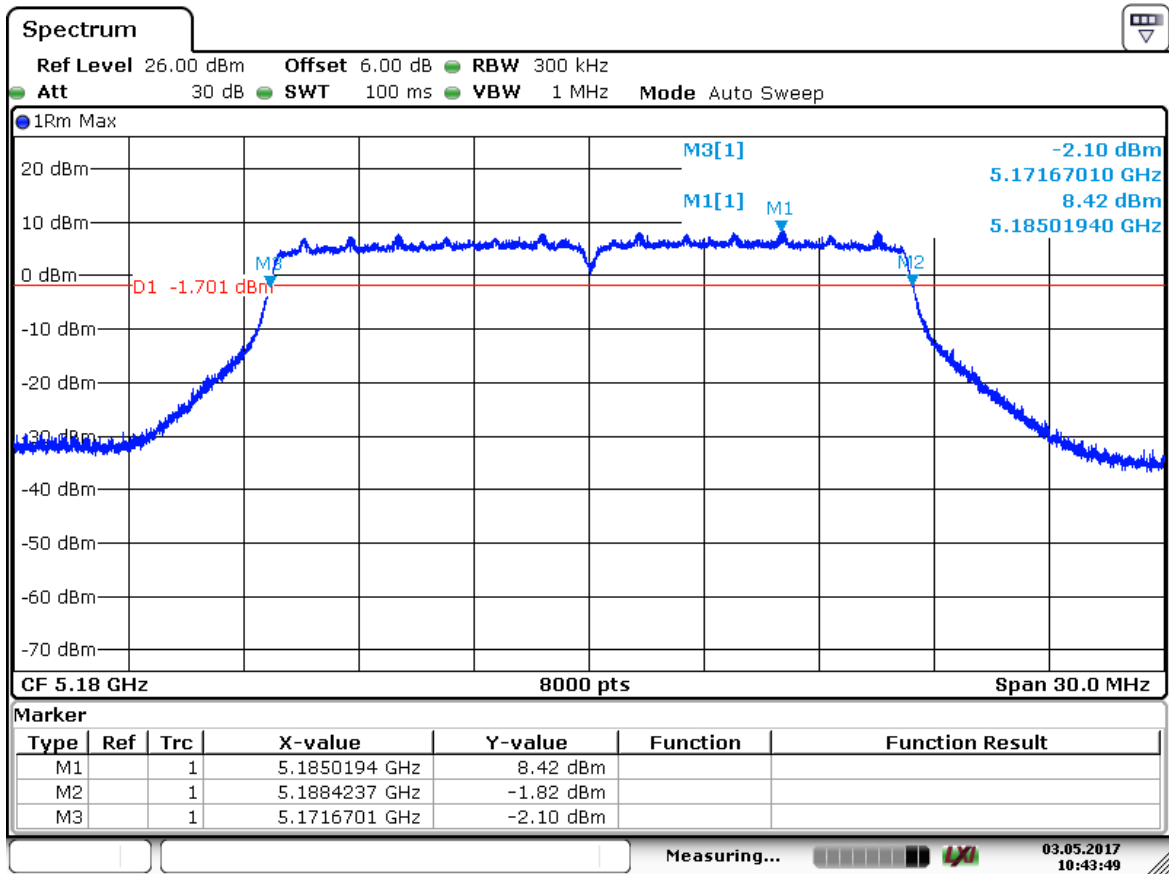

Date: 3 MAY 2017 10:43:49

Figure 97: Frequency Stability – Worst Case

4.8 Voltage Variation

In accordance with 47 CFR Part 15.31 (e) intentional radiators, measurements of the variation of the input power or the radiated signal level of the fundamental frequency component of the emission, as appropriate, shall be performed with the supply voltage varied between 85% and 115% of the nominal rated supply voltage. For battery operated equipment, the equipment tests shall be performed using a new battery.

4.8.1 Test Methodology

The ac supply voltage was varied between 85% and 115% of the nominal rated supply voltage. The fundamental frequency was observed during the variation. The access point was powered 120 Vac / 60 Hz by programmable power supply. The voltage was varied from 102 Vac to 138 Vac mean while the fundamental frequencies were observed and record for the maximum drift in ppm; part per millions.

4.8.2 Test results

As originally tested, the EUT was found to be compliant to the requirements of the test standard(s). The fundamental frequencies drifted less than ± 20 ppm.

Table 26: Voltage Variation – Test Results

Frequency	Nominal (120Vac)	Lo Voltage (102Vac)	Hi Voltage (138Vac)	Max Drift
MHz	MHz	MHz	MHz	ppm
5180	4.31	4.31	-2.87	4.31

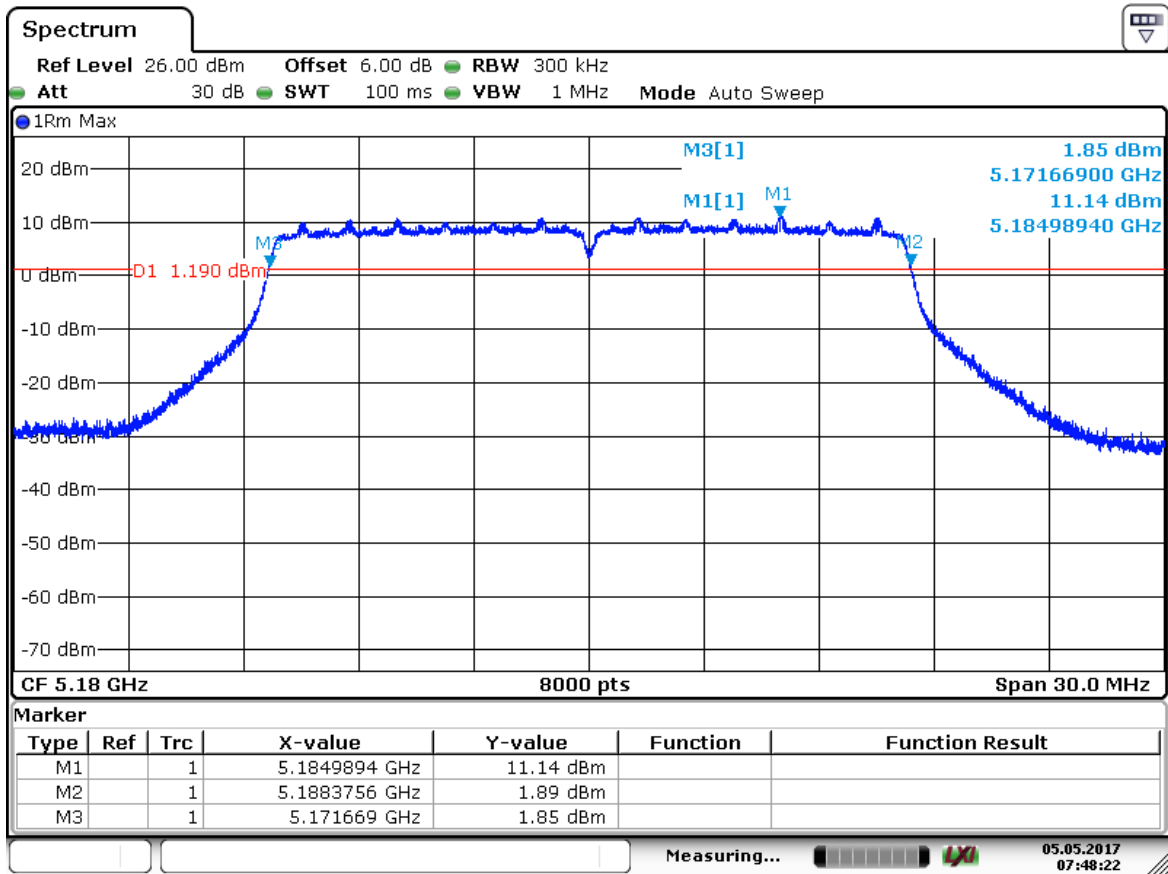

Date: 5 MAY 2017 07:48:22

Figure 98: Voltage Variation – Worst Case

4.9 Maximum Permissible Exposure

4.9.1 Test Methodology

In this document, we try to prove the safety of radiation harmfulness to the human body for our product. The limit for Maximum Permissible Exposure (MPE) specified in FCC 1.1310 is followed. The Gain of the antenna used in this calculation is declared by the manufacturer, and the maximum total power input to the antenna is measured. Through the Friis transmission formula and the maximum gain of the antenna, we can calculate the distance, away from the product, where the limit of MPE is reached.

Although the Friis transmission formula is a far field assumption, the calculated result of that is an over-prediction for near field power density. We will take that as the worst case to specify the safety range.

4.9.2 RF Exposure Limit

According to FCC 1.1310 table 1: The criteria listed in the following table shall be used to evaluate the environmental impact of human exposure to radio-frequency (RF) radiation as specified in 1.1307(b)

LIMITS FOR MAXIMUM PERMISSIBLE EXPOSURE (MPE)

Frequency Range (MHz)	Electric Field Strength (V/m)	Magnetic Field Strength (A/m)	Power Density (mW/cm ²)	Average Time (minutes)
(A)Limits For Occupational / Control Exposures				
0.3–3.0	614	1.63	*(100)	6
3.0–30	1842/f	4.89/f	*(900/f ²)	6
30–300	1.0	6
300 - 1500	f/300	6
1500 - 100,000	5	6
(B)Limits For General Population / Uncontrolled Exposure				
0.3–1.34	614	1.63	*(100)	30
1.34-30	824/f	2.19/f	*(180/ f ²)	30
30–300	27.5	0.037	0.2	30
300 - 1500	f/1500	30
1500 - 100,000	1.0	30

F = Frequency in MHz

* = Plane-wave equivalent power density

4.9.3 EUT Operating Condition

The software provided by Manufacturer enabled the EUT to transmit data at lowest, middle and highest channel individually.

4.9.4 Classification

The antenna of the product, under normal use condition, is at least 20cm away from the body of the user. Warning statement to the user for keeping at least 20cm or more separation distance with the antenna should be included in user's manual. So, this device is classified as a **Mobile Device**.

See below calculation for 5.24 GHz, worse case, RF Exposure at a distance of 20cm.

4.9.5 Test Results

4.9.5.1 Antenna Gain

The 5.24 GHz transmitting beam forming antenna gain was +6.84 dBi or 4.83 (numeric).

4.9.5.2 Output Power into Antenna & RF Exposure value at distance 20cm:

Calculations for this report are based on highest power measurement.

Limit for MPE (from FCC part 1.1310 table1) is 1.0 mW/cm²

The highest measured total power is +29.05 dBm or 803.53 mW (summed 2 chains)

Using the Friss transmission formula, the EIRP is Pout*G, and R is 20cm.

$P_d = (803.53 * 4.83) / (1600\pi) = 0.7721 \text{ mW/cm}^2$, which is 0.2279 mW/cm² below to the limit.

As originally tested, the EUT was found to be compliant to the requirements of the test standard(s).

4.9.6 Sample Calculation

The Friss transmission formula: $P_d = (P_{out} * G) / (4 * \pi * R^2)$

Where;

P_d = power density in mW/cm²

P_{out} = output power to antenna in mW

G = gain of antenna in linear scale

$\pi \approx 3.1416$

R = distance between observation point and center of the radiator in cm

Ref. : David K. Cheng, *Field and Wave Electromagnetics*, Second Edition, Page 640, Eq. (11-133).

5 Test Equipment List

5.1 Equipment List

Equipment	Manufacturer	Model #	Serial/Inst #	Last Cal mm/dd/yyyy	Next Cal mm/dd/yyyy
Bilog Antenna	Sunol Sciences	JB3	A102606	06/15/2016	06/15/2018
Horn Antenna	Sunol Sciences	3115	9710-5301	10/08/2015	10/08/2017
Antenna (18-40 GHz)	Com-Power	AHA-840	105005	07/08/2015	07/08/2017
Loop Antenna	EMCO	6502	9110-2683	06/13/2016	06/13/2017
Spectrum Analyzer	Rohde & Schwarz	FSL6	100169	01/13/2017	01/13/2018
Spectrum Analyzer	Agilent	N9038A	MY552260210	01/16/2017	01/16/2018
Spectrum Analyzer	Agilent	N9030A	MY52350885	05/17/2016	05/17/2017
Spectrum Analyzer	Rohde Schwarz	ESIB40	832427/002	01/16/2017	01/16/2018
Spectrum Analyzer	Rohde Schwarz	FSV40	1321.3008K40	08/30/2016	08/30/2017
Amplifier	Sonoma Instruments	310	165516	01/19/2017	01/19/2018
Amplifier	Miteq	TTA1800-30-HG	2020728	11/12/2016	11/12/2017
Amplifier	Rohde & Schwarz	TS-PR26	100011	11/04/2017	11/04/2018
Amplifier	Rohde & Schwarz	TS-PR40	100012	08/02/2017	08/02/2017
Power Meter	Agilent	E4418B	MY45103902	01/11/2017	01/11/2018
Power Sensor	Hewlett Packard	8482A	1925A04647	01/01/2017	01/01/2018
Thermometer	Fluke	52II	88650033	11/04/2016	11/04/2017
Thermo Chamber	Espec	BTZ-133	0613436	NCR	NCR
Multimeter	Fluke	177	92780312	01/11/2017	01/11/2018
DC Power Supply	Agilent	E3634A	MY400004331	01/12/2017	01/12/2018
Notch Filter	Micro-Tronics	BRM50702	037	07/18/2016	07/18/2017
Signal Generator	Anritsu	MG3694A	42803	01/13/2017	01/13/2018
Signal Generator	Rohde & Schwarz	SMF100A	1167.0000K02	09/06/2016	09/06/2017
Signal Generator	Rohde & Schwarz	SMBV100A	1407.6004K02	09/06/2016	09/06/2017
Power Sensors	Rohde & Schwarz	OSP120	1520.9010.02	09/06/2016	09/06/2017

* Calibration of equipment past due for re-calibration will be performed expeditiously. If any equipment is found to be out of tolerance at that time, affected customers will be notified accordingly.

6 EMC Test Plan

6.1 Introduction

This section provides a description of the Equipment Under Test (EUT), configurations, operating conditions, and performance acceptance criteria. It is an overview of information provided by the manufacturer so that the test laboratory may perform the requested testing.

6.2 Customer

Table 27: Customer Information

Company Name	eero inc.
Address	500 Howard Street, Suite 900
City, State, Zip	San Francisco, CA 94105
Country	USA
Phone	(415) 738-7972
Fax	

Table 28: Technical Contact Information

Name	Clifford Clarke
E-mail	cliff@eero.com
Phone	(415) 738-7972
Fax	

6.3 Equipment Under Test (EUT)

Table 29: EUT Specifications

EUT Specifications	
Dimensions	W: 4.75in (121mm) x D: 4.75in (121mm) x H: 0.85-1.26in (22-33mm)
AC Input	100-240V AC, 50 – 60 Hz
Environment	Indoor
Operating Temperature Range:	0 to 35 degrees C
Multiple Feeds:	<input type="checkbox"/> Yes and how many <input checked="" type="checkbox"/> No
Product Marketing Name (PMN)	B010001 (USA), B010002 (IC)
Hardware Version Identification Number (HVIN)	B010001 (USA), B010002 (IC)
Firmware Version Identification Number (FVIN)	3.0.0
802.11-radio modules	
Operating Mode	802.11a, 802.11n (HT20, HT40), 802.11ac (VHT20, VHT40, VHT80)
Transmitter Frequency Band	5.150 GHz – 5.250 GHz, U-NII-1 band
Max. Rated Power Output	See Channel Planning Table.
Power Setting @ Operating Channel	See Channel Planning Table.
Antenna Type	Qty 7 – 2 custom antennas at 5.18-5.24GHz. See Table 30 for details
Antenna Gain	Antenna 1 = +3.01 dBi, Antenna 3 = +4.58 dBi
Modulation Type	<input type="checkbox"/> AM <input type="checkbox"/> FM <input checked="" type="checkbox"/> DTS <input checked="" type="checkbox"/> OFDM <input type="checkbox"/> Other describe: 16QAM and 64 QAM
Data Rate	802.11a: 1 Spatial Streams: 6, 9, 12, 18, 24, 36, 48, 54 Mbps 802.11n/ac HT20/VHT20: 2 Spatial Streams: 13, 26, 39, 52, 78, 104, 117, 130 /156 Mbps (LGI) 802.11n/ac HT40/VHT40: 2 Spatial Streams: 27, 54, 81, 108, 162, 216, 243, 270 / 324, 370 Mbps (LGI) 802.11ac VHT 80: 2 Spatial Streams: 58.5, 117, 175.5, 234, 351, 468, 526.5, 585, 702, 780 Mbps (LGI)
TX/RX Chain (s)	MIMO (2x2)

EUT Specifications	
Directional Gain Type	<input type="checkbox"/> Correlated <input checked="" type="checkbox"/> Beam-Forming <input type="checkbox"/> Other describe:
Type of Equipment	<input checked="" type="checkbox"/> Table Top <input checked="" type="checkbox"/> Wall-mount <input type="checkbox"/> Floor standing cabinet <input type="checkbox"/> Other:
Note: All 2 chains will be on / transmitted at all time.	

Table 30: Antenna Information

Number	Antenna Type	Description	Max Gain (dBi)
Antenna 1	Flex PCB	5 GHz Wi-Fi U-NII-1 Band, Chain 0	3.01
Antenna 1	Flex PCB	5 GHz Wi-Fi U-NII-2A Band, Chain 0	2.52
Antenna 2	Flex PCB	Bluetooth LE and Thread (Zigbee)	3.09
Antenna 3	Flex PCB	5 GHz Wi-Fi U-NII-1 Band, Chain 1	4.58
Antenna 3	Flex PCB	5 GHz Wi-Fi U-NII-2A Band, Chain 1	4.37
Antenna 4	Flex PCB	2.4 GHz Wi-Fi Chain 0	3.84
Antenna 5	Flex PCB	5 GHz Wi-Fi U-NII-2C Band, Chain 0	4.46
Antenna 5	Flex PCB	5 GHz Wi-Fi U-NII-3 Band, Chain 0	3.84
Antenna 6	Flex PCB	5 GHz Wi-Fi U-NII-2C Band, Chain 1	3.34
Antenna 6	Flex PCB	5 GHz Wi-Fi U-NII-3 Band, Chain 1	3.29
Antenna 7	Flex PCB	2.4 GHz Wi-Fi Chain 1	5.43

Table 31: EUT Channel Power Specifications

FCC Total Power for Non-Beamforming Mode

No.	Frequency (MHz)	Target Power Value dBm					
		802.11a	802.11n HT20	802.11n HT40	802.11ac VHT40	802.11ac VHT80	
36	5180	25.93****	26.15*****				
38	5190			22.60***	22.08**		
42	5210					19.99*	
46	5230			28.94*****	29.05*****		
48	5240	27.19*****	27.88*****				

Note: 1. The adjusted power target values are updated at the evaluated frequencies.
 2. TP setting: * = 19, ** = 20, *** = 20.5, ****=23.5, *****=24, ***** = 25, ***** = 26, ***** = 26.5.

RSS Total Power for Non-Beamforming Mode

No.	Frequency (MHz)	Target Power Value dBm					
		802.11a	802.11n HT20	802.11n HT40	802.11ac VHT40	802.11ac VHT80	
36	5180	15.64*	15.85**				
38	5190			17.88***	17.92***		
42	5210					18.18*****	
46	5230			17.82***	17.81***		
48	5240	15.38*	15.47**				

Note: 1. The adjusted power target values are updated at the evaluated frequencies.
 2. TP setting: * = 13.5, ** = 14, *** = 16, **** = 16.5.

FCC Total Power for Beamforming Mode

No.	Frequency (MHz)	Target Power Value dBm					
		802.11a	802.11n HT20	802.11n HT40	802.11ac VHT40	802.11ac VHT80	
36	5180	25.93****	26.15*****				
38	5190			22.60***	22.08**		
42	5210					19.99*	
46	5230			28.94*****	29.05*****		
48	5240	26.17*****	27.88*****				

Note: 1. The adjusted power target values are updated at the evaluated frequencies.
 2. TP setting: * = 19, ** = 20, *** = 20.5, ****=23.5, ***** = 24, ***** = 25, ***** = 26.5.

RSS Total Power for Beamforming Mode

No.	Frequency (MHz)	Target Power Value dBm					
		802.11a	802.11n HT20	802.11n HT40	802.11ac VHT40	802.11ac VHT80	
36	5180	13.49*	13.68**				
38	5190			15.97***	15.98***		
42	5210					15.69*****	
46	5230			15.86***	15.82***		
48	5240	13.20*	13.31**				

Note: 1. The adjusted power target values are updated at the evaluated frequencies.
 2. TP setting: * = 11.5, ** = 12, *** = 14, **** = 14.5.

Table 32: Interface Specifications

Interface Type	Cabled with what type of cable?	Is the cable shielded?	Maximum potential length of the cable?	Metallic (M), Coax (C), Fiber (F), or Not Applicable?
Ethernet	RJ45	<input checked="" type="checkbox"/> No	<input checked="" type="checkbox"/> Metric: 2 m	<input type="checkbox"/> N/A

Table 33: Supported Equipment

Equipment	Manufacturer	Model	Serial	Used for
Laptop	Dell	Latitude	35521341769	Setup EUT operating channel
Note: None.				

Table 34: Description of Sample used for Testing

Device	Serial	RF Connection	CFR47 Part 15.407
Wi-Fi Router	SPE28JY	FPCB Antenna	TX Emission, AC Conducted Emission
		Direct Connection	Peak Transmit Power, Peak Power Spectral Density, Occupied Bandwidth Band-Edge Out-of-Band Emission
Note: N/A			

Table 35: Description of Test Configuration used for Radiated Measurement.

Device	Antenna	Mode	Setup Photo (X-Axis)	Setup Photo (Y-Axis)	Setup Photo (Z-Axis)
Wi-Fi Router	FPCB	Transmit	EUT laid flat	N/A	N/A
Note: N/A					

6.4 Test Specifications

Testing requirements

Table 36: Test Specifications

Emissions and Immunity	
Standard	Requirement
CFR 47 Part 15.407: 2016	All
RSS 247 Issue 2, 2017	All

END OF REPORT