

---

1E0671-1 MCR2.9

1E0671 LCM

---

Installation Instruction

Version 1.00

29.4.2015

HABERL ELECTRONIC

Kochstraße 2

94424 Arnstorf

+49 8723 9622-0

[info@haberl-electronic.de](mailto:info@haberl-electronic.de)

## Content

About these instructions .....	3
Contents of Installation Kit.....	3
Installation .....	4
Precautions of Use .....	6
Technical Assistance .....	7

This document and its contents are proprietary to haberl electronic GmbH & Co. KG and are intended solely for the contractual use of its customer in connection with the use of the product(s) described herein and for no other purpose. This document and its contents shall not be used or distributed for any other purpose and/or otherwise communicated, disclosed, or reproduced in any way whatsoever without the prior written consent of haberl electronic.

The instructions in this document must be strictly and explicitly followed by qualified and properly trained personnel in order to ensure the proper and safe use of the product(s) described herein. All of the contents of this document must be fully read and understood prior to using such product(s).

FAILURE TO COMPLETELY READ AND EXPLICITLY FOLLOW ALL OF THE INSTRUCTIONS CONTAINED HEREIN MAY RESULT IN DAMAGE TO THE PRODUCT(S), INJURY TO PERSONS, INCLUDING TO USERS OR OTHERS, AND DAMAGE TO OTHER PROPERTY.

HABERL ELECTRONIC DOES NOT ASSUME ANY LIABILITY ARISING OUT OF THE IMPROPER USE OF THE PRODUCT(S) DESCRIBED HEREIN (INCLUDING PARTS THEREOF OR SOFTWARE) OR ANY USE OF SUCH PRODUCT(S) OUTSIDE THE SCOPE OF THE EXPRESS WRITTEN LICENSES OR PERMISSIONS GRANTED BY HABERL ELECTRONIC IN CONNECTION WITH CUSTOMER'S ACQUISITION OF SUCH PRODUCT(S).

© 20153 haberl electronic GmbH & Co. KG , All rights reserved.

## About these instructions

These instructions describe the physical installation of a MCR2.9/ LCM unit. For a complete List of RFID commands and functionality, please refer to the reference manual for your operating system.

## Contents of Installation Kit

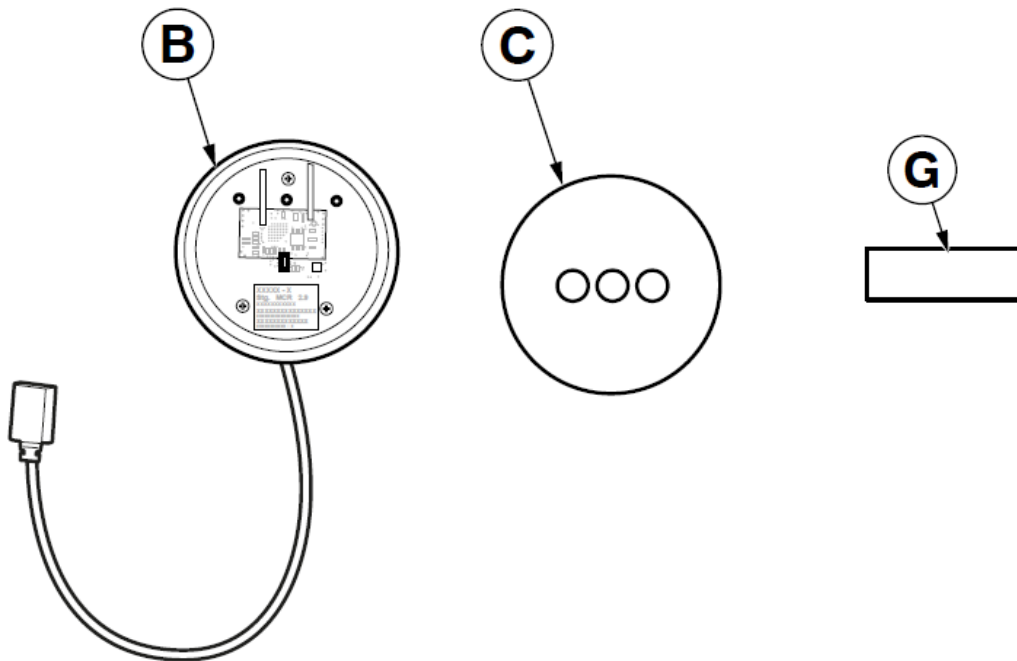

Explanation:

B: LCM / MCR2.9

C: label

G: diffusion disk

## Installation

- Remove the A-Pillar covering on the driver side.
- Connect the plug A322\*1B, which is behind the A-pillar covering, with the cable of the LCM/MCR2.9 unit.

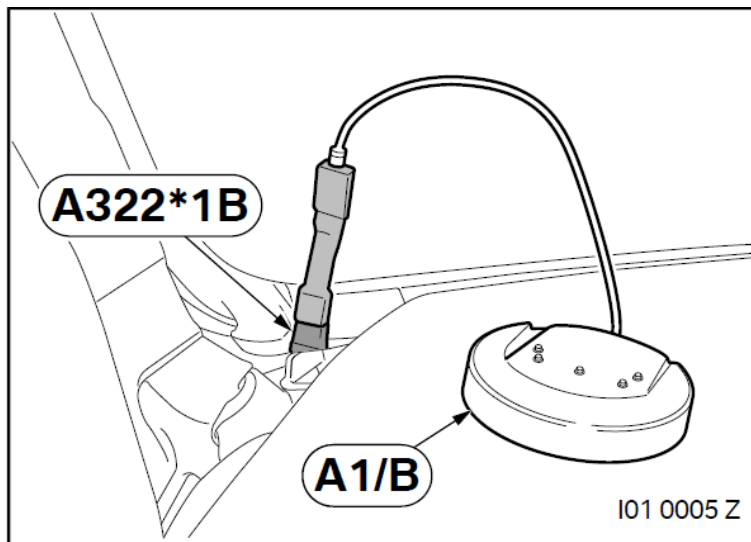

Place the A-pillar covering on his position again.

Position the label on the corner of the front window.

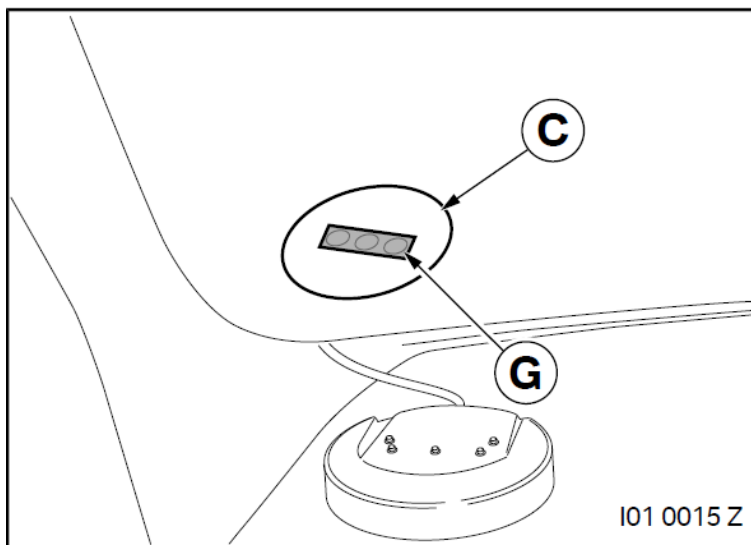

Put the diffusion disk above the 3 holes.

Artikel: 1E0671-1

Bezeichnung: MCR 2.9

---

Remove the red cap of the ring, which is on top of the LCM/MCR2.9.

Stick the Reader above the label. Be care that the 3 LEDs are behind the 3 holes on the label.

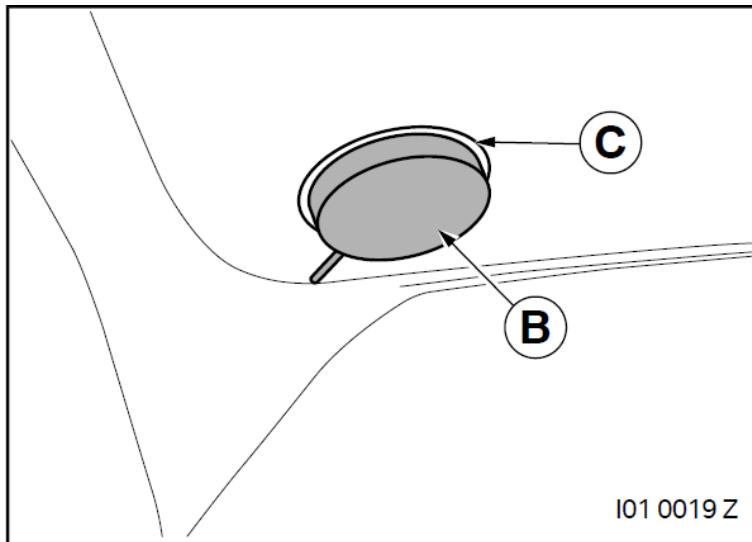

The installation is finished.

## **Precautions of Use**

### **Avoid using the RFID Reader in the presence of strong electromagnetic waves.**

The RFID Reader supplies power to the card or tag using an electromagnetic wave to communicate with the card or tag. The presence of strong electromagnetic waves affects communication between the RFID Reader and card or tag, causing reduced access area or inability to access the card. Test the RFID Reader using the actual power source in the installation location environment before use.

### **Keep precision devices that might be affected by electromagnetic waves away from the RFID Reader.**

Because the RFID Reader constantly emits an electromagnetic wave of about 125 KHz and 13.56 MHz, placing precision devices that might be affected by electromagnetic waves near the reader can cause malfunction or failure of the devices. When operating the reader, keep precision devices away from the RFID Reader. If such precision devices must be located near the RFID Reader, shield the precision devices with a metal cover and test the devices to check for any influence.

### **Avoid using multiple RFID Readers in proximity to each other.**

The RFID Reader supplies power to the card or tag using an electromagnetic wave to communicate with the card or tag and constantly emits an electromagnetic wave of about 125 KHz and 13.56 MHz. Using multiple readers in proximity to each other causes interference, interrupts communication between the card and reader, and prevents access to the card.

## Safety Information

To maintain compliance with the FCC RF exposure guidelines, install and operate this equipment with a minimum distance of 20 cm between the radiator and your body.

Use only with the supplied antenna. Unauthorized antenna, modification, or attachments can damage the transmitter and violate FCC regulations.

## Technical Assistance

Haberl electronic general contact information:

Haberl electronic GmbH & Co. KG

Kochstrasse 2

D-94424 Arnstorf

Tel. +49-8723-9622-0

Fax: +49-8723-9622-33

Email: [info@haberl-electronic.de](mailto:info@haberl-electronic.de)