



FCC TEST REPORT FCC 47 CFR Part 22H Industry Canada RSS-132, Issue 3 Cellular Telephones Operating in the Bands 824-849MHz and 869-894MHz FCC 47 CFR Part 24E Industry Canada RSS-133, Issue 6 2GHz Personal Communication Services	
Report Reference No.:	G0M-1502-4503-TFC224GS-V01
Testing Laboratory	Eurofins Product Service GmbH
Address.....:	Storkower Str. 38c 15526 Reichenwalde Germany
Accreditation	<div style="display: flex; justify-content: center; align-items: center;">   </div> <p style="text-align: center; font-size: small;">A2LA Accredited Testing Laboratory, Certificate No.: 1983.01 FCC Filed Test Laboratory, Reg.-No.: 96970 IC OATS Filing assigned code: 3470A</p>
Applicant's name	SMT & Hybrid GmbH
Address.....:	An der Priessnitzau 22 01328 Dresden GERMANY
Test specification:	Standard
	47 CFR Part 22H, 47 CFR Part 24E RSS-132, Issue 3 : 2013-01, RSS-133, Issue 6 : 2013-01 SRSP-503 Issue 7 : 2008-09, SRSP-510 Issue 5 : 2009-02 RSS-Gen, Issue 4, 2014-11, ANSI/TIA-603-C-2004
Equipment under test (EUT):	
Product description	Datenlogger
Model No.	data link sensor
Additional Model(s)	None
Brand Name(s)	MONI LOG data link sensor
Hardware version	R3
Firmware / Software version	0.90
	FCC-ID: 2AELT-08MONILOG Contains IC: 5131A-HE910
Test result	Passed

Possible test case verdicts:

- neither assessed nor tested: N/N
- required by standard but not appl. to test object.....: N/A
- required by standard but not tested.....: N/T
- not required by standard for the test object: N/R
- test object does meet the requirement.....: P (Pass)
- test object does not meet the requirement.....: F (Fail)

Testing:

Test Lab Temperature.....: 20 – 23 °C

Test Lab Humidity: 32 – 38 %

Date of receipt of test item: 2015-03-23

Date (s) of performance of tests: 2015-06-08 - 2015-06-11

Compiled by: Matthias Handrik

Tested by (+ signature).....: Matthias Handrik 
 (Responsible for Test)

Approved by (+ signature): Christian Weber 
 (Head of Lab)

Date of issue: 2015-06-18

Total number of pages: 28

General remarks:

The test results presented in this report relate only to the object tested.

The results contained in this report reflect the results for this particular model and serial number. It is the responsibility of the manufacturer to ensure that all production models meet the intent of the requirements detailed within this report.

This report shall not be reproduced, except in full, without the written approval of the Issuing testing laboratory.

Additional comments:

Version History

Version	Issue Date	Remarks	Revised by
01	2015-06-18	Initial Release	

REPORT INDEX

1	EQUIPMENT (TEST ITEM) DESCRIPTION	5
1.1	Photos – Equipment External	7
1.2	Photos – Equipment internal	8
1.3	Photos – Test setup	10
1.4	Supporting Equipment Used During Testing	11
1.5	Test Modes	12
1.6	Test Equipment Used During Testing	13
1.7	Sample emission level calculation	14
2	RESULT SUMMARY	15
3	TEST CONDITIONS AND RESULTS	16
3.1	Test Conditions and Results – Occupied Bandwidth	16
3.2	Test Conditions and Results – Effective radiated power / Equivalent isotropic radiated power	23
3.3	Test Conditions and Results – Transmitter radiated emissions	25
3.4	Test Conditions and Results – Receiver radiated emissions	27

1 Equipment (Test item) Description

Description	Datenlogger		
Model	data link sensor		
Additional Model(s)	None		
Brand Name(s)	MONI LOG data link sensor		
Serial number	20158xxx		
Hardware version	R3		
Software / Firmware version	0.90		
FCC-ID	2AELT-08MONILOG		
Contains IC	5131A-HE910		
Equipment type	End product		
Equipment classification	Mobile Device (Human Body distance > 20 cm)		
Radio type	Transceiver		
Radio technology	GSM850 / GSM1900		
Operating frequency range	GSM850 : TX = 824 - 849 MHz, RX = 869 - 894 MHz GSM1900 : TX = 1850 - 1910 MHz, RX = 1930 - 1990 MHz		
Assigned frequency band	Cell. Service Block A & B : 824 - 849 MHz & 869 - 894 MHz Broadband PCS : 1850 - 1910 MHz & 1930 - 1990 MHz		
Main test frequencies GSM850	F _{LOW}	CH : 128 UL: 824.2 MHz	CH : 128 DL: 869.2 MHz
	F _{MID}	CH : 188 UL: 836.2 MHz	CH : 188 DL: 881.2 MHz
	F _{HIGH}	CH : 251 UL: 848.8 MHz	CH : 251 DL: 893.8 MHz
Main test frequencies GSM1900	F _{LOW}	CH : 512 UL: 1850.2 MHz	CH : 512 DL: 1930.2 MHz
	F _{MID}	CH : 661 UL: 1880.0 MHz	CH : 661 DL: 1960.0 MHz
	F _{HIGH}	CH : 810 UL: 1909.8 MHz	CH : 810 DL: 1989.8 MHz
Supported transmission modes	GSM, GPRS		
Modulations	GSM, GPRS : GMSK		
Multislot class	10		
Number of antennas	1		
Radio module	Type	GSM/GPRS module	
	Model	HE910-G	
	Manufacturer	Telit Wireless Solutions	
	HW Version	00	
	SW Version	12.00.xx5	
	FCC-ID	RI7HE910	
	IC	5131A-HE910	
Antenna	Type	external dedicated	
	Model	TG 22.0111	
	Manufacturer	Taoglas	
	Gain	2.14 dBi (customer declaration)	

Test Report No.: G0M-1502-4503-TFC224GS-V01

Manufacturer	SMT & Hybrid GmbH An der Priessnitzau 22 01328 Dresden GERMANY	
Power supply	V _{NOM}	6 or 12 VDC
	V _{MIN}	N/A
	V _{MIN}	N/A
AC/DC-Adaptor	Model	N/A
	Vendor	N/A
	Input	N/A
	Output	N/A

1.1 Photos – Equipment External

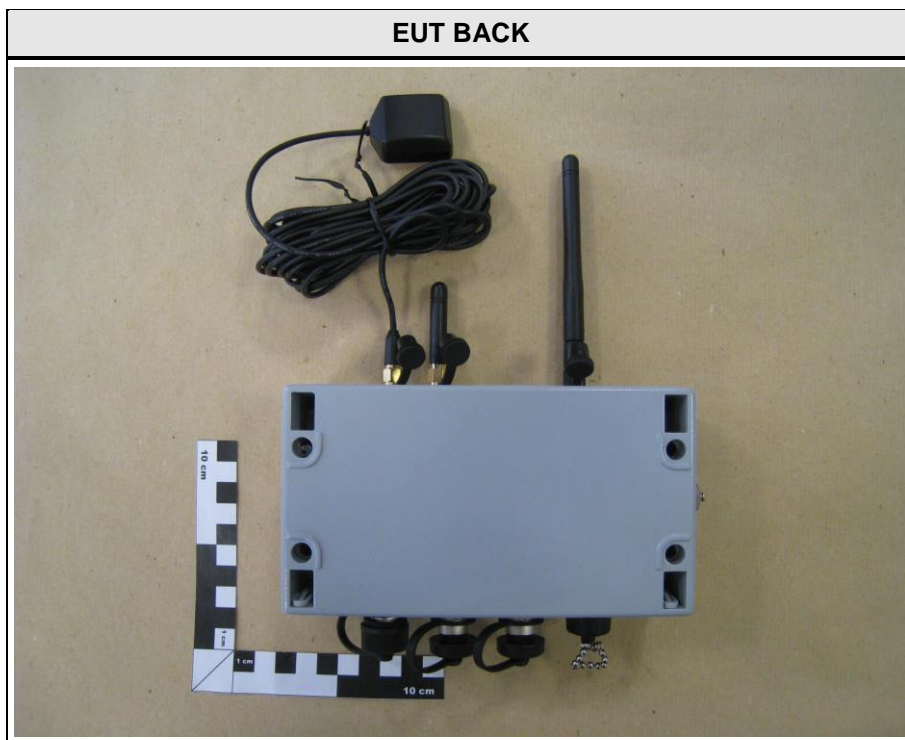

1.2 Photos – Equipment internal

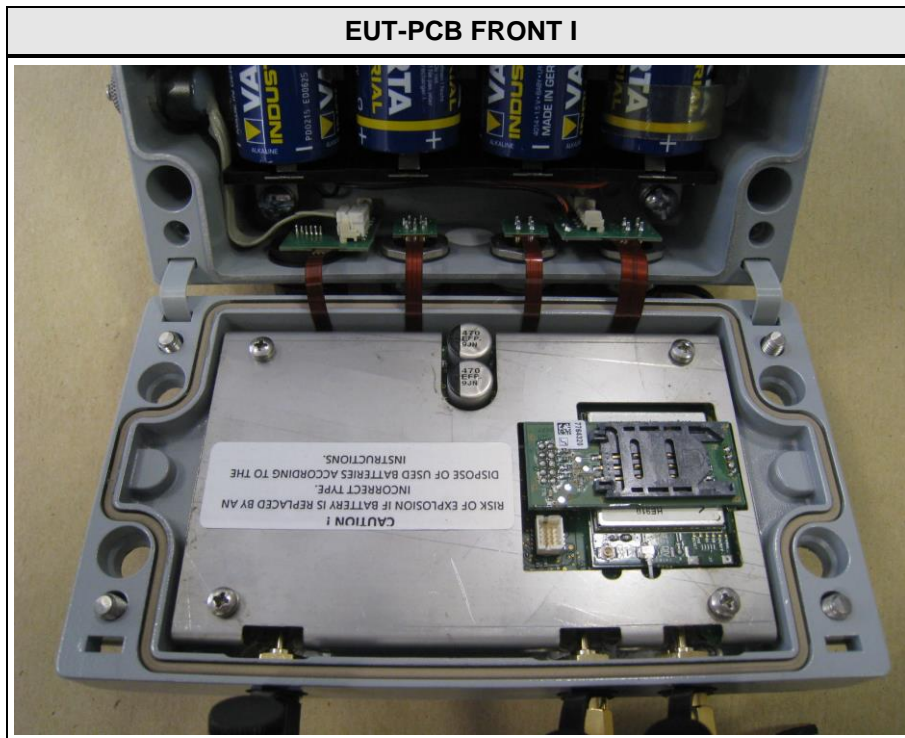
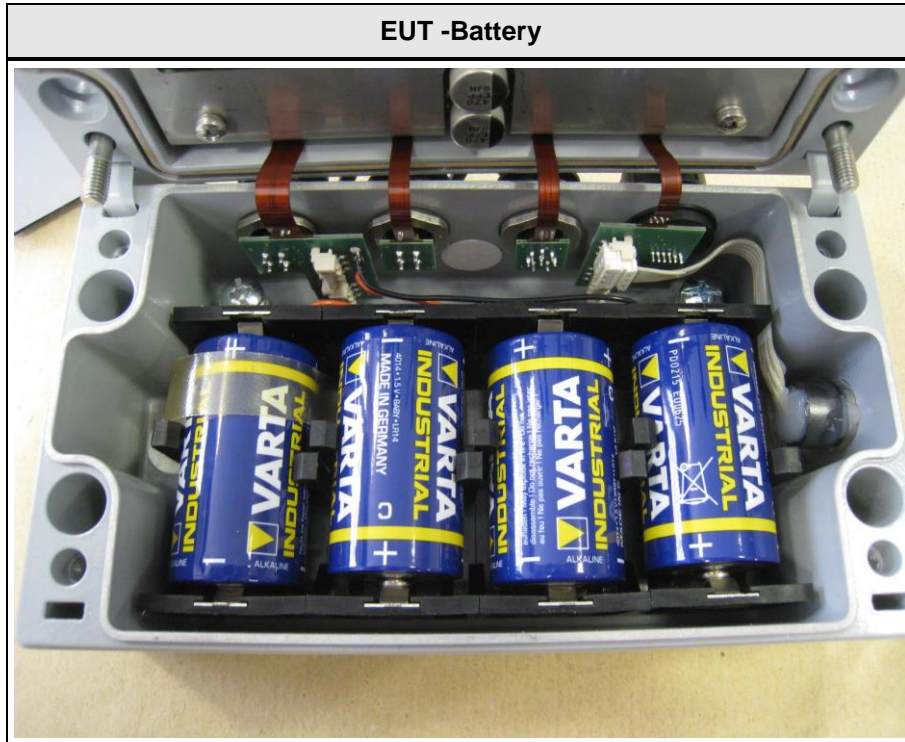

EUT-PCB FRONT II

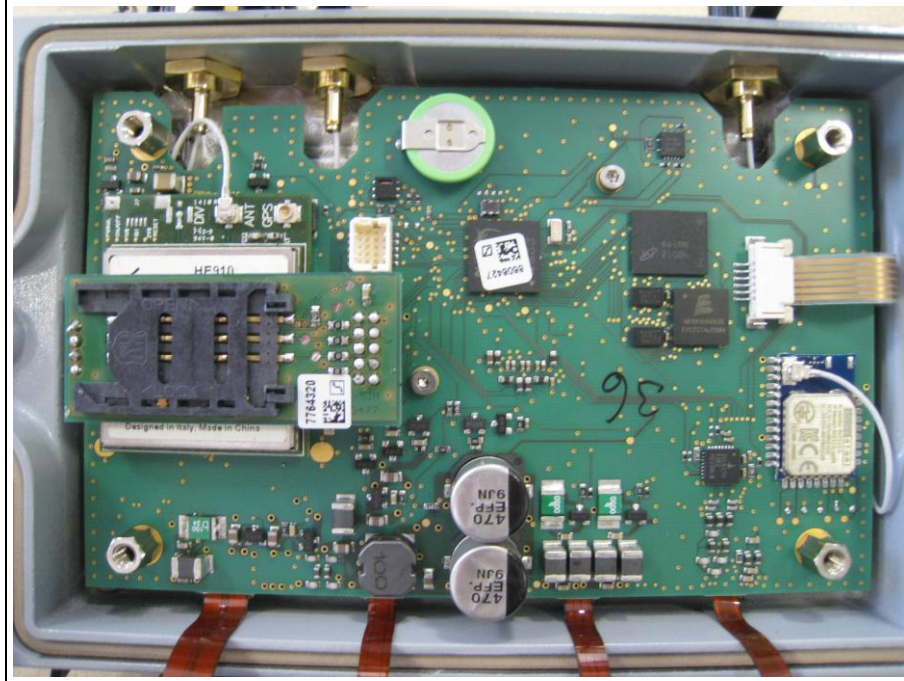

EUT-PCB BACK



1.3 Photos – Test setup

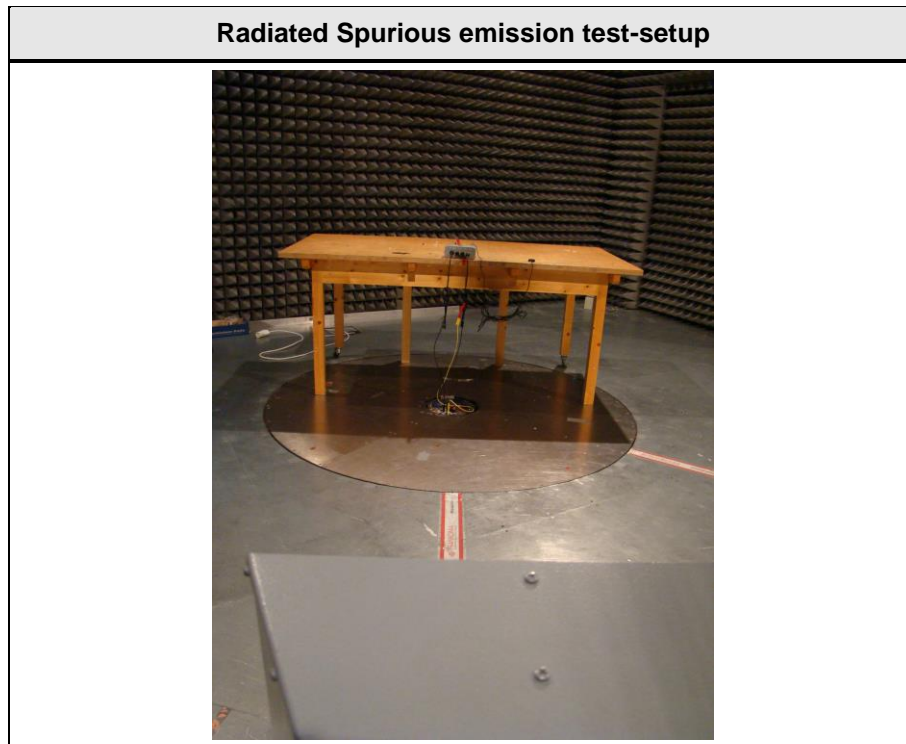

1.4 Supporting Equipment Used During Testing

Product Type*	Device	Manufacturer	Model No.	Comments
SIM	Radio communication tester	R&S	CMU200	
SIM : Simulator (Not Subjected to Test)				

1.5 Test Modes

Mode #	Description	
GSM850	General conditions:	EUT powered by laboratory power supply. External GSM and GPS antenna connected. Active data call to communication tester.
	Radio conditions:	Mode = transmit Connection = Packet data Modulation = GMSK Slot configuration = 1 up / 1 down Power level = Maximum (Gamma 3)
GSM1900	General conditions:	EUT powered by laboratory power supply. External GSM and GPS antenna connected. Active data call to communication tester.
	Radio conditions:	Mode = transmit Connection = Packet data Modulation = GMSK Slot configuration = 1 up / 1 down Power level = Maximum (Gamma 3)

1.6 Test Equipment Used During Testing

Measurement Software			
Description	Manufacturer	Name	Version
EMC Test Software	Dare Instruments	Radimation	2014.1.15

Occupied Bandwidth					
Description	Manufacturer	Model	Identifier	Cal. Date	Cal. Due
Spectrum Analyzer	R&S	FSIQ 26	EF00242	2015-04	2016-04

Radiated power					
Description	Manufacturer	Model	Identifier	Cal. Date	Cal. Due
Fully-anechoic chamber	Frankonia	AC 3	EF00199	-	-
Spectrum Analyzer	R&S	FSIQ 26	EF00242	2015-04	2016-04
Biconical Antenna	R&S	HK 116	EF00012	2013-02	2016-02
LPD Antenna	R&S	HL 223	EF00187	2014-03	2017-03
Horn antenna	Schwarzbeck	BBHA 9120D	EF00019	2014-03	2016-03

Radiated spurious emissions					
Description	Manufacturer	Model	Identifier	Cal. Date	Cal. Due
Semi-anechoic chamber	Frankonia	AC 1	EF00062	-	-
Spectrum Analyzer	R&S	FSEK 30	EF00168	2015-01	2016-01
Biconical Antenna	R&S	HK 116	EF00012	2013-02	2016-02
LPD Antenna	R&S	HL 223	EF00212	2013-02	2016-02
Horn antenna	Schwarzbeck	BBHA 9120D	EF00019	2014-03	2016-03

1.7 Sample emission level calculation

The following is a description of terms and a sample calculation, as appears in the radiated emissions data table. The numbers used in the calculation are for example only. There is no direct correlation to the specific data taken for the product described in this document:

Reading:

This is the reading obtained on the spectrum analyzer in dB μ V. Any external preamplifiers used are taken into account through internal analyzer settings.

A.F.:

This is the antenna factor for the receiving antenna. It is a conversion factor, which converts electric fields strengths to voltages, which can be measured directly on the spectrum analyzer. It is treated as a loss in dB. Cable losses have been included with the A.F. to simplify the calculations. The antenna factor is used in calculations as follows:

$$\text{Reading on Analyzer (dB}\mu\text{V)} + \text{A.F. (dB)} = \text{Net field strength (dB}\mu\text{V/m)}$$

Net:

This is the net field strength measurement (as shown above).

Limit:

This is the FCC Class B radiated emission limit (in units of dB μ V/m). The FCC limits are given in units of μ V/m. The following formula is used to convert the units of μ V/m to dB μ V/m:

$$\text{Limit (dB}\mu\text{V/m)} = 20 * \log (\mu\text{V/m})$$

Margin:

This is the margin of compliance below the FCC limit. The units are given in dB. A negative margin indicates the emission was below the limit. A positive margin indicates that the emission exceeds the limit.

Example only:

$$\begin{array}{rclcl} \text{Reading} & + & \text{AF} & = & \text{Net Reading} & : & \text{Net reading} - \text{FCC limit} & = & \text{Margin} \\ 21.5 \text{ dB}\mu\text{V} & + & 26 \text{ dB} & = & 47.5 \text{ dB}\mu\text{V/m} & : & 47.5 \text{ dB}\mu\text{V/m} - 57.0 \text{ dB}\mu\text{V/m} & = & -9.5 \text{ dB} \end{array}$$

2 Result Summary

FCC 47 CFR Part 22H, 24E, IC RSS-132, 133				
Product Specific Standard Section	Requirement – Test	Reference Method	Result	Remarks
RSS-Gen 6.6	Occupied Bandwidth	RSS-Gen 6.6		Informational only
FCC § 24.235 FCC § 22.355 IC RSS-132 § 4.3 IC RSS-133 § 6.3	Frequency stability	FCC § 24.235 FCC § 22.355 IC RSS-132 § 4.3 IC RSS-133 § 6.3	N/R	Conducted results of licensed radio unaffected. See module radio report.
FCC § 22.913(a)	Effective radiated power	ANSI/TIA-603-C	PASS	
FCC § 24.232(c) IC RSS-132 § 4.4 IC RSS-133 § 6.4	Equivalent isotropic radiated power	ANSI/TIA-603-C	PASS	
FCC § 24.232(d) IC RSS-133 § 6.4	Peak to average ratio	FCC § 24.232(d) IC RSS-133 § 6.4	N/R	Conducted results of licensed radio unaffected. See module radio report
FCC § 22.917(b) FCC § 24.238(b) IC RSS-132 § 4.5 IC RSS-133 § 6.5	Band-edge compliance	FCC § 22.917(b) FCC § 24.238(b) IC RSS-132 § 4.5 IC RSS-133 § 6.5	N/R	Conducted results of licensed radio unaffected. See module radio report
FCC § 22.917(a) FCC § 24.238(a) IC RSS-132 § 4.5 IC RSS-133 § 6.5	Conducted out-of-band emissions	FCC § 22.917(a) FCC § 24.238(a) IC RSS-132 § 4.5 IC RSS-133 § 6.5	N/R	Conducted results of licensed radio unaffected. See module radio report
FCC § 22.917(a) FCC § 24.238(a) IC RSS-132 § 4.5 IC RSS-133 § 6.5	Radiated out-of-band emissions	ANSI/TIA-603-C	PASS	
IC RSS-132 § 4.6 IC RSS-133 § 6.6 IC RSS-Gen 7.1	Receiver radiated spurious emissions	IC RSS-132 § 4.6 IC RSS-133 § 6.6 IC RSS-Gen 7.1	PASS	
Remarks:				

3 Test Conditions and Results

3.1 Test Conditions and Results – Occupied Bandwidth

Occupied Bandwidth acc. to IC RSS-Gen			
Test according to measurement reference	Reference Method		
	RSS-Gen 6.6		
Test frequency range	Tested frequencies		
	$F_{LOW} / F_{MID} / F_{HIGH}$		
Limits			
None (Informational only)			
Test setup			
 <pre> graph LR SA[Spectrum Analyzer] --- EUT[EUT] </pre>			
Test procedure			
<ol style="list-style-type: none"> EUT set to test mode (Communication tester is used if needed) Span set to at least twice the emission spectrum Resolution bandwidth set to 1 % of span Occupied Bandwidth (99 %) measurement with spectrum analyzer built in measurement function 			
Test results – GSM850			
Channel	Frequency [MHz]	Mode	Occupied Bandwidth [kHz]
F_{LOW}	824.2	GPRS 850	390.782
F_{MID}	836.2	GPRS 850	390.782
F_{HIGH}	848.8	GPRS 850	390.782
Test results – GSM1900			
Channel	Frequency [MHz]	Mode	Occupied Bandwidth [kHz]
F_{LOW}	1850.2	GPRS 1900	393.788
F_{MID}	1880	GPRS 1900	396.794
F_{HIGH}	1909.8	GPRS 1900	393.788
Comments:			

Occupied Bandwidth – GPRS850 F_{Low}
Occupied Bandwidth acc. to RSS-Gen

Project Number: G0M-1502-4503

Applicant: SMT & Hybrid GmbH
 EUT Name: Datenlogger
 Model: data link sensor
 Test Site: Eurofins Product Service GmbH
 Operator: Handrik
 Test Conditions: Tnom / Vnom
 Mode: GPRS 850, CH 128, UL 1x Slot, Gamma 3
 Test Date: 2015-06-11
 Verdict: NONE (INFORMATION ONLY)
 Note 1: A spectrum analyzer with an integrated 99% power bandwidth function is used

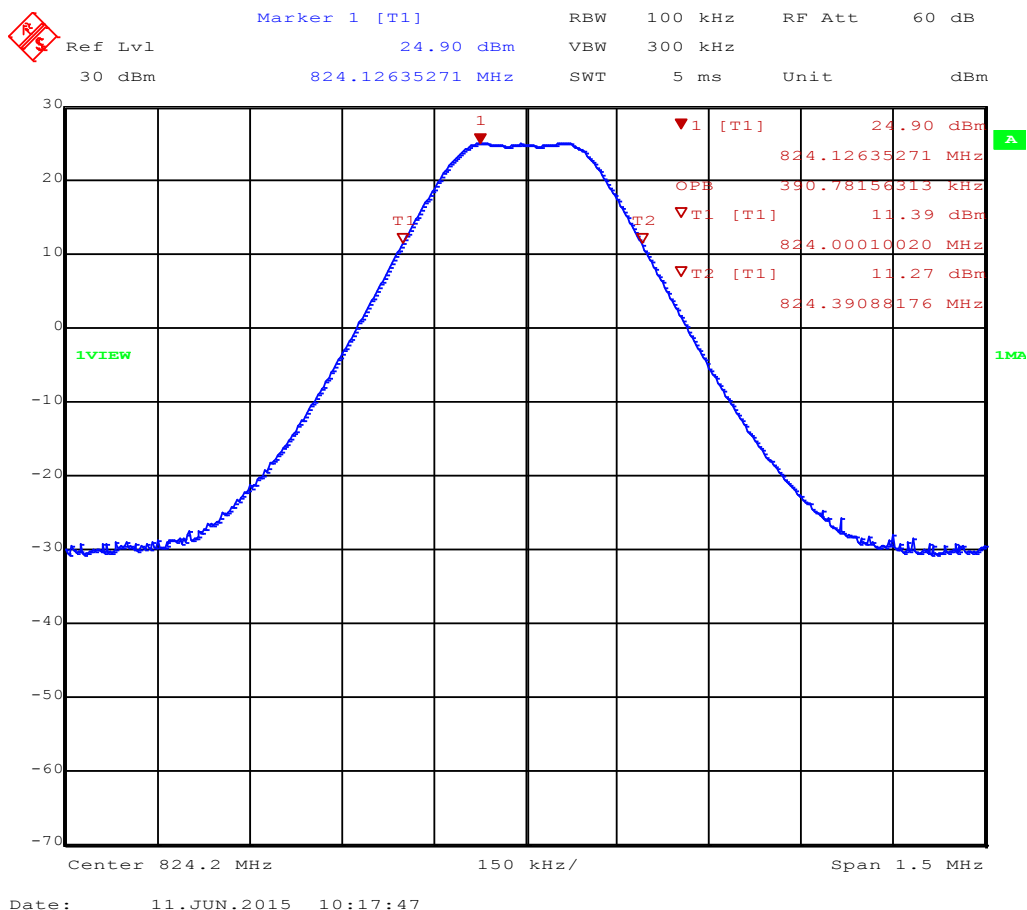

Occupied Bandwidth – GPRS850 F_{MID}
Occupied Bandwidth acc. to RSS-Gen

Project Number: G0M-1502-4503

Applicant: SMT & Hybrid GmbH
 EUT Name: Datenlogger
 Model: data link sensor
 Test Site: Eurofins Product Service GmbH
 Operator: Handrik
 Test Conditions: Tnom / Vnom
 Mode: GPRS 850, CH 188, UL 1x Slot, Gamma 3
 Test Date: 2015-06-11
 Verdict: NONE (INFORMATION ONLY)
 Note 1: A spectrum analyzer with an integrated 99% power bandwidth function is used

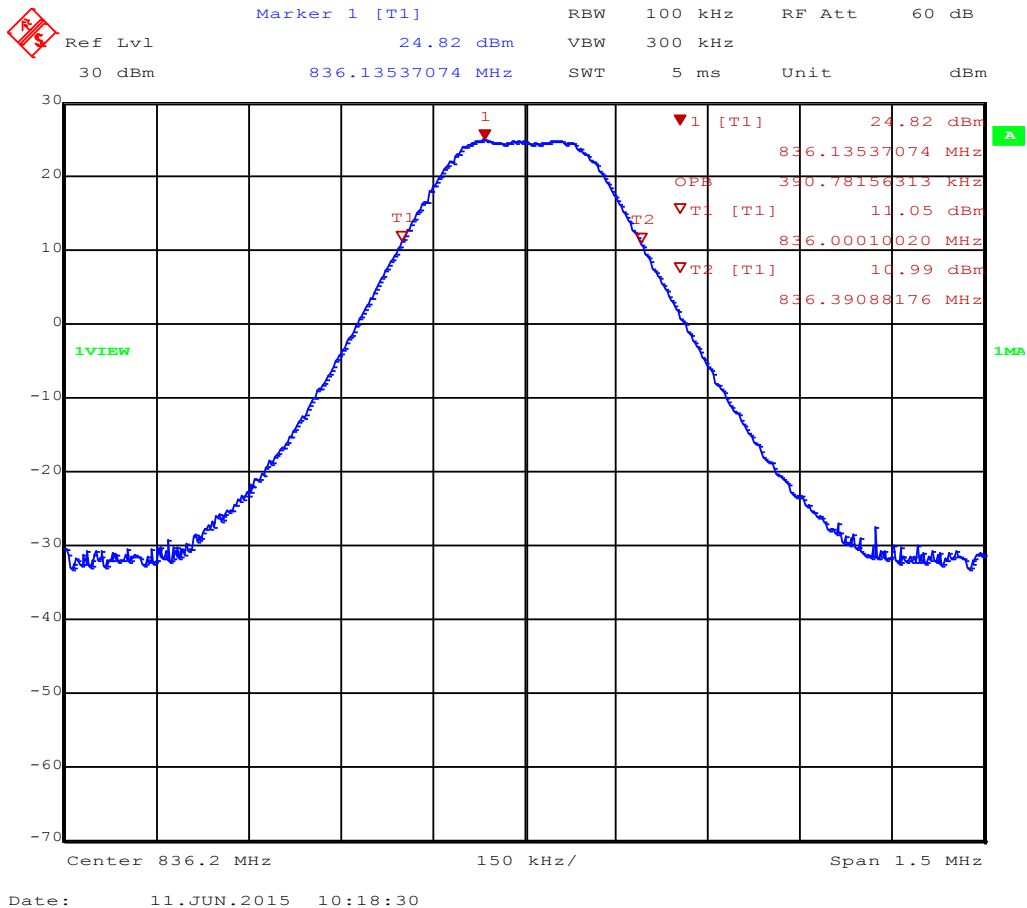

Occupied Bandwidth – GPRS850 F_{HIGH}
Occupied Bandwidth acc. to RSS-Gen

Project Number: G0M-1502-4503

Applicant: SMT & Hybrid GmbH
 EUT Name: Datenlogger
 Model: data link sensor
 Test Site: Eurofins Product Service GmbH
 Operator: Handrik
 Test Conditions: Tnom / Vnom
 Mode: GPRS 850, CH 251, UL 1x Slot, Gamma 3
 Test Date: 2015-06-11
 Verdict: NONE (INFORMATION ONLY)
 Note 1: A spectrum analyzer with an integrated 99% power bandwidth function is used

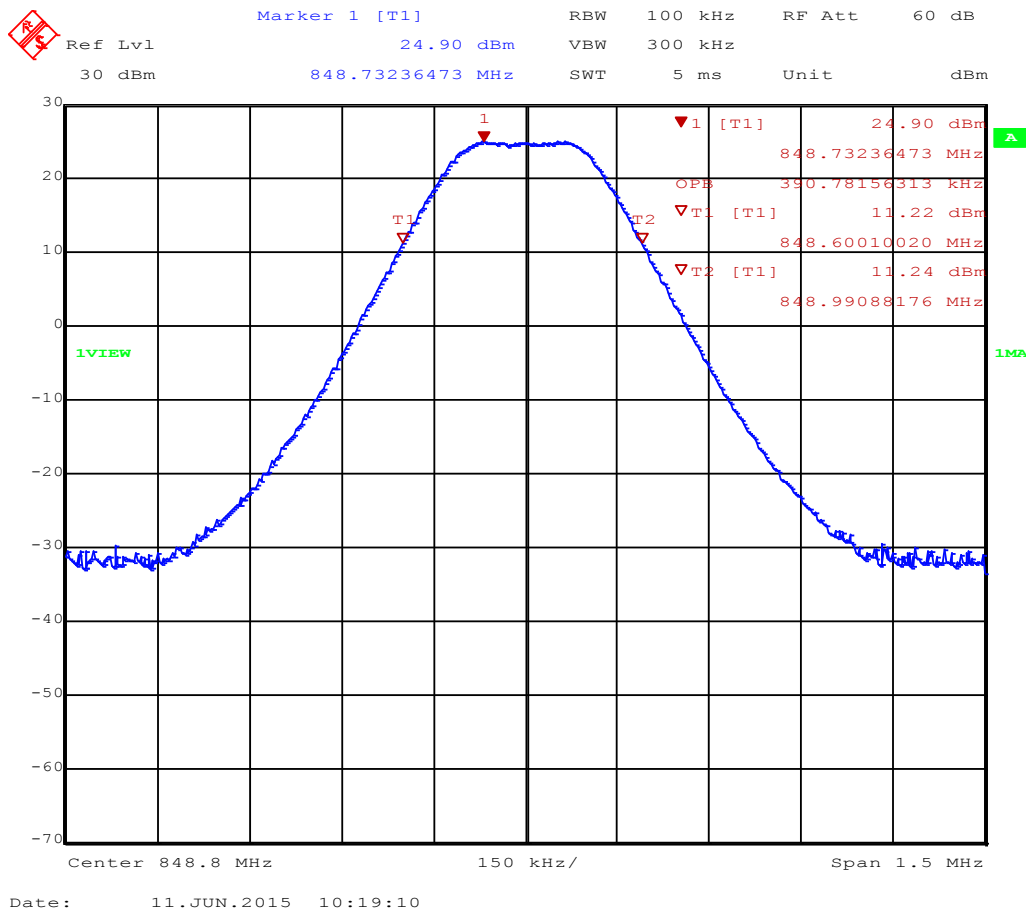

Occupied Bandwidth – GPRS1900 F_{Low}
Occupied Bandwidth acc. to RSS-Gen

Project Number: G0M-1502-4503

Applicant: SMT & Hybrid GmbH
 EUT Name: Datenlogger
 Model: data link sensor
 Test Site: Eurofins Product Service GmbH
 Operator: Handrik
 Test Conditions: Tnom / Vnom
 Mode: GPRS 1900, CH 512, UL 1x Slot, Gamma 3
 Test Date: 2015-06-11
 Verdict: NONE (INFORMATION ONLY)
 Note 1: A spectrum analyzer with an integrated 99% power bandwidth function is used

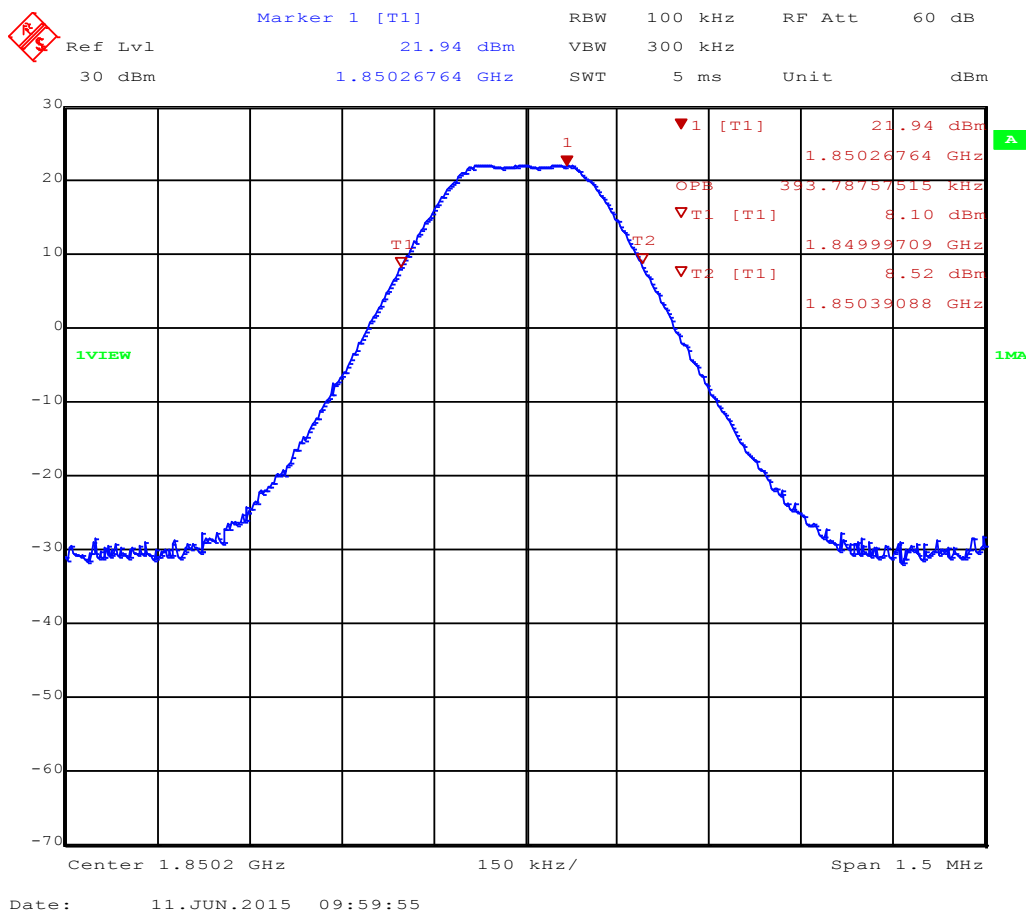

Occupied Bandwidth – GPRS1900 F_{MID}
Occupied Bandwidth acc. to RSS-Gen

Project Number: G0M-1502-4503

Applicant: SMT & Hybrid GmbH
 EUT Name: Datenlogger
 Model: data link sensor
 Test Site: Eurofins Product Service GmbH
 Operator: Handrik
 Test Conditions: Tnom / Vnom
 Mode: GPRS 1900, CH 661, UL 1x Slot, Gamma 3
 Test Date: 2015-06-11
 Verdict: NONE (INFORMATION ONLY)
 Note 1: A spectrum analyzer with an integrated 99% power bandwidth function is used

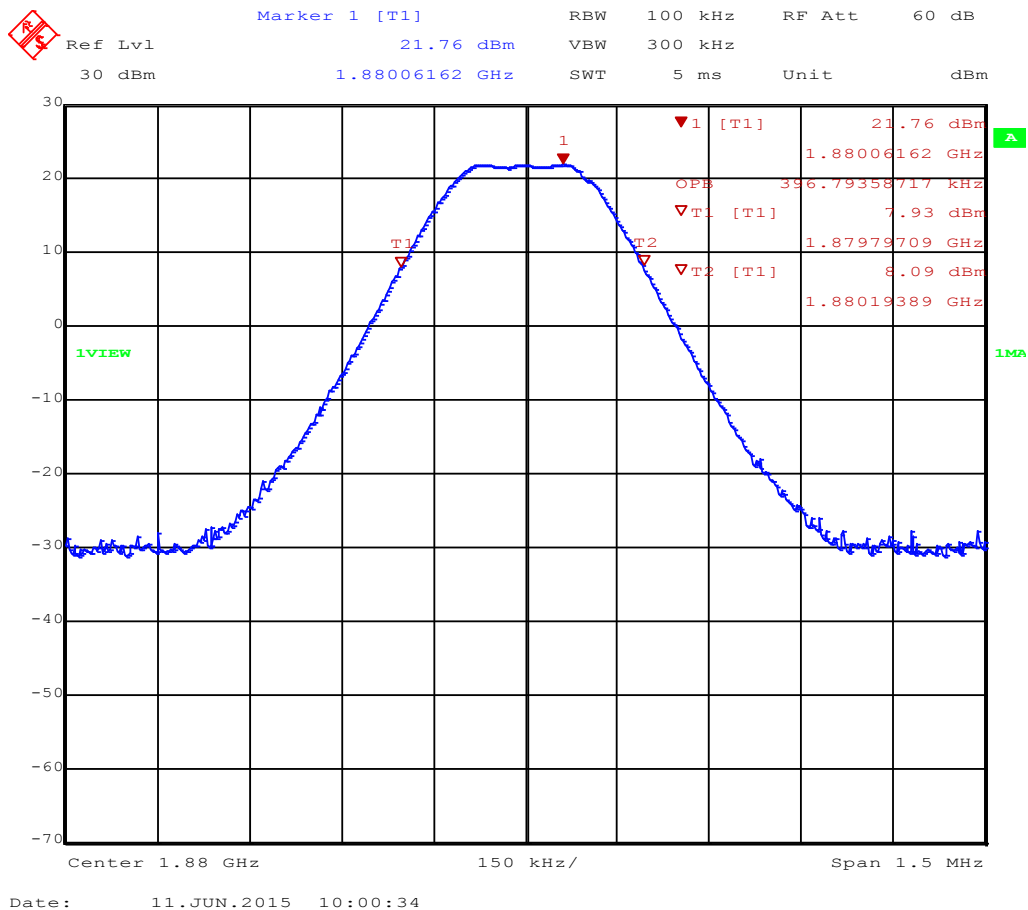

Occupied Bandwidth – GPRS1900 F_{HIGH}
Occupied Bandwidth acc. to RSS-Gen

Project Number: G0M-1502-4503

Applicant: SMT & Hybrid GmbH
 EUT Name: Datenlogger
 Model: data link sensor
 Test Site: Eurofins Product Service GmbH
 Operator: Handrik
 Test Conditions: Tnom / Vnom
 Mode: GPRS 1900, CH 810, UL 1x Slot, Gamma 3
 Test Date: 2015-06-11
 Verdict: NONE (INFORMATION ONLY)
 Note 1: A spectrum analyzer with an integrated 99% power bandwidth function is used

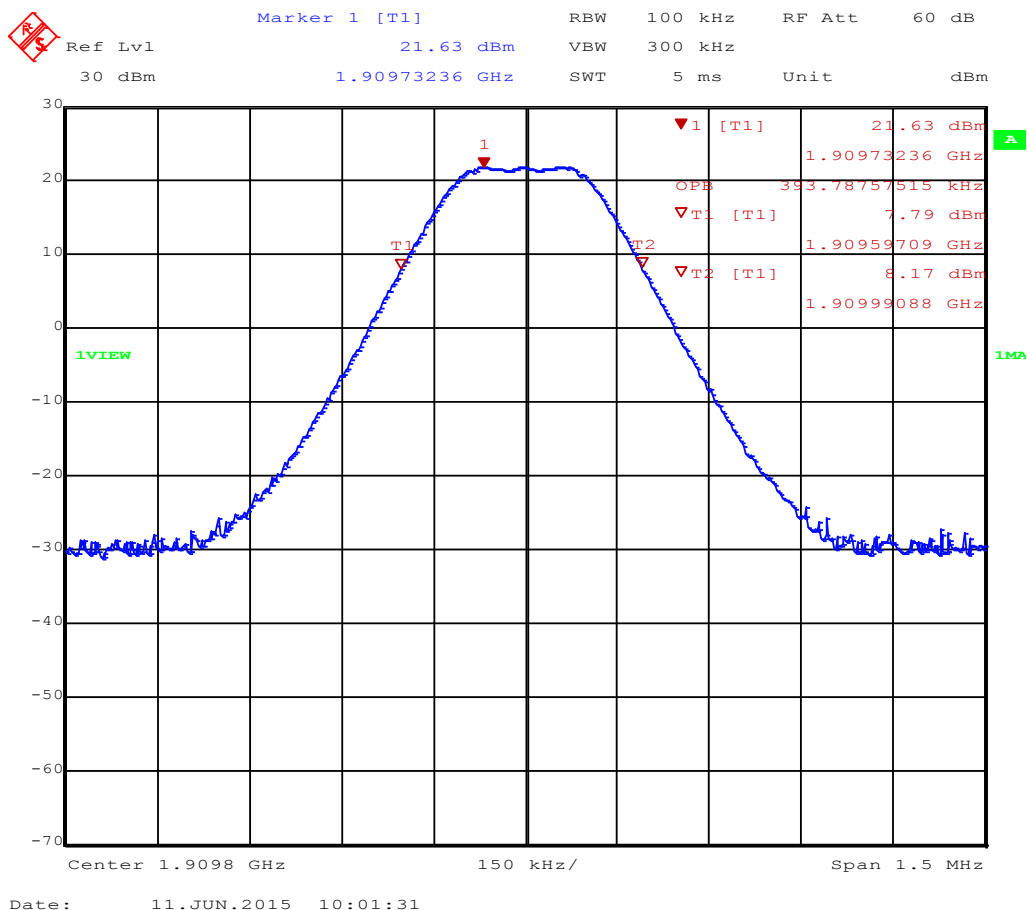

3.2 Test Conditions and Results – Effective radiated power / Equivalent isotropic radiated power

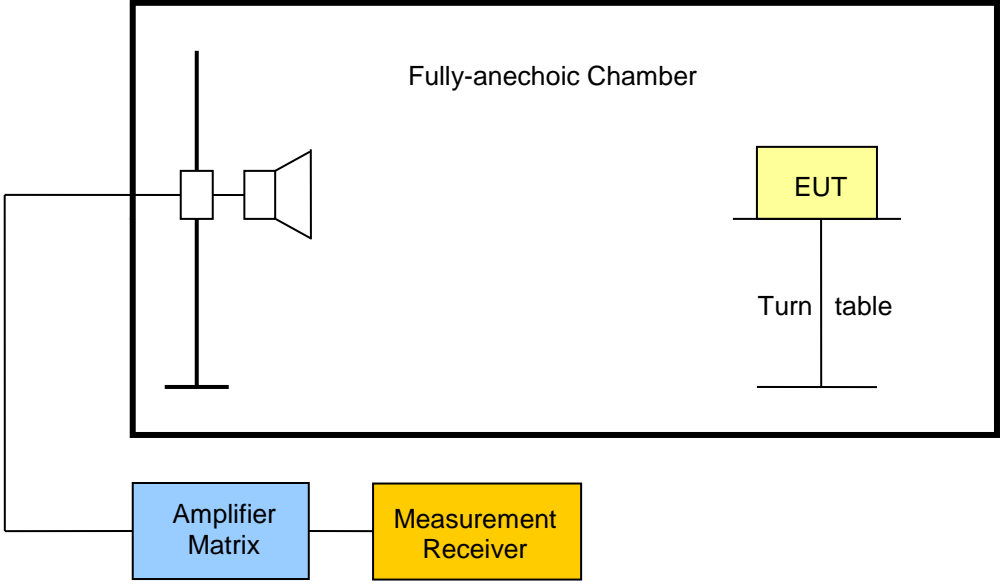
Radiated power acc. to FCC 22H / FCC 24E / IC RSS-132 / IC RSS-133		Verdict: PASS
EUT requirement rule parts and clause	Reference	
	FCC § 22.913(a) / FCC § 24.232(c) IC RSS-132 § 4.4 /IC RSS-133 § 6.4	
Test according to measurement reference	Reference Method	
	FCC § 22.913(a) / FCC § 24.232(c) / ANSI/TIA-603-C IC RSS-132 § 4.4 /IC RSS-133 § 6.4	
Test frequency range	Tested frequencies	
	$F_{LOW} / F_{MID} / F_{HIGH}$	
Limits		
Frequency range	Equipment type	Power limit
824-849 MHz	Mobile transmitter	FCC : 7 Watts (38.45 dBm) e.i.r.p. IC : 11.5 Watts (40.6 dBm) e.i.r.p.
1850-1910 MHz	Mobile transmitter	FCC : 2 Watts (33 dBm) e.i.r.p. IC : 2 Watts (33 dBm) e.i.r.p.
Test setup		
		
Test procedure		
<ol style="list-style-type: none"> 1. EUT set to test mode 2. The radiated power is measured with a measurement antenna in vertical polarization 3. To obtain maximum level the EUT is rotated 4. The EUT is replaced with a half-wave dipole and the power to the dipole is adjusted to obtain same radiated power measurement value 		

Test results – GSM850 E.R.P.							
Channel	Frequency [MHz]	Mode	Pol.	Power [dBm e.r.p]	Limit [dBm e.r.p]	Margin [dB]	Result
F _{LOW}	824.2	GPRS 850	ver	24.8	38.45	-13.65	PASS
F _{MID}	836.2	GPRS 850	ver	26.3	38.45	-12.15	PASS
F _{HIGH}	848.8	GPRS 850	ver	28.2	38.45	-10.25	PASS
Test results – GSM850 E.I.R.P.							
Channel	Frequency [MHz]	Mode	Pol.	Power [dBm e.i.r.p]	Limit [dBm e.i.r.p]	Margin [dB]	Result
F _{LOW}	824.2	GPRS 850	ver	26.95	40.6	-13.65	PASS
F _{MID}	836.2	GPRS 850	ver	28.45	40.6	-12.15	PASS
F _{HIGH}	848.8	GPRS 850	ver	30.35	40.6	-10.25	PASS
Test results – GSM1900 E.I.R.P.							
Channel	Frequency [MHz]	Mode	Pol.	Power [dBm e.i.r.p]	Limit [dBm e.i.r.p]	Margin [dB]	Result
F _{LOW}	1850.2	GPRS 1900	hor	30.4	33	-02.60	PASS
F _{MID}	1880	GPRS 1900	hor	29.4	33	-03.60	PASS
F _{HIGH}	1909.8	GPRS 1900	hor	30.4	33	-02.60	PASS
Comments:							

3.3 Test Conditions and Results – Transmitter radiated emissions

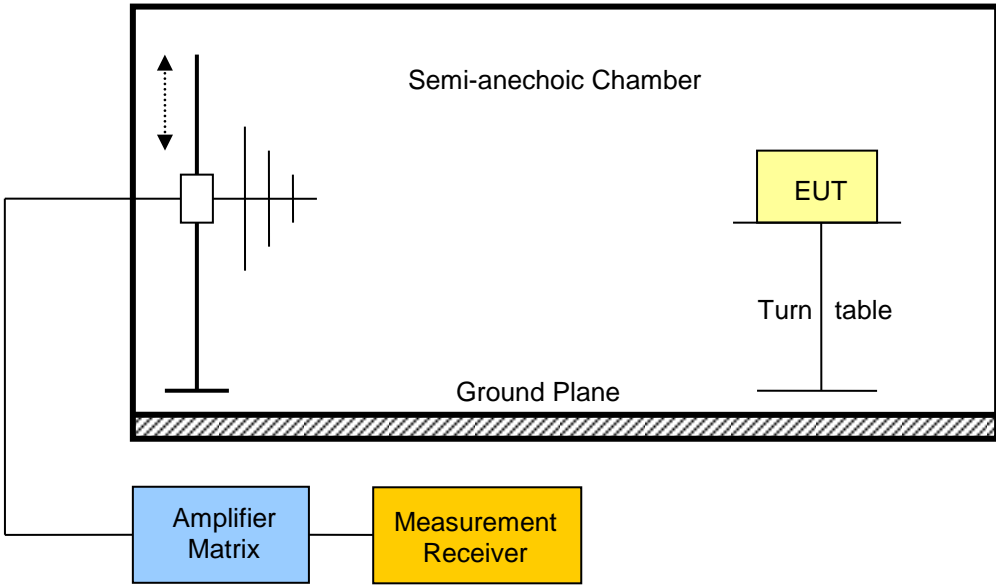
Transmitter radiated power acc. to FCC 22H / FCC 24E / IC RSS-132 / IC RSS-133		Verdict: PASS
Test according referenced standards	Reference Method	
	FCC § 22.917(a) / FCC § 24.238(a) IC RSS-132 § 4.5 / IC RSS-133 § 6.5	
Test according to measurement reference	Reference Method	
	ANSI/TIA-603-C	
Test frequency range	Tested frequencies	
	30 MHz – 10 th Harmonic	
Limits		
Frequency range	Limit	
824-849 MHz	Attenuation below transmitter power $\geq 43 + 10 \cdot \log_{10}(P)$ [dB] = -13 dBm	
1850-1910 MHz	Attenuation below transmitter power $\geq 43 + 10 \cdot \log_{10}(P)$ [dB] = -13 dBm	
Test setup		
 <p>The diagram illustrates the test setup within a Semi-anechoic Chamber. A Ground Plane is at the bottom. An antenna is positioned on the left, connected to an Amplifier Matrix. The EUT (Equipment Under Test) is placed on a Turn table on the right. A Measurement Receiver is connected to the Amplifier Matrix. The antenna height is adjustable, as indicated by a vertical double-headed arrow.</p>		
Test procedure		
<ol style="list-style-type: none"> 1. EUT set to test mode 2. Maximum emission level is measured by rotating the EUT and adjusting the antenna height for vertical polarization 3. The EUT is replaced by a substitution antenna and generator 4. The power level is set to obtain the same power reading 5. Measurement is repeated for horizontal polarization 		

Test results – GSM850								
Channel	Frequency [MHz]	Mode	Emission [MHz]	Level [dBm]	Pol.	Limit [dBm]	Margin [dB]	
CH. 128	824.2	GPRS 850	823.996	-19.40	hor	-13.00	-06.41	
CH. 128	824.2	GPRS 850	823.998	-21.20	ver	-13.00	-08.23	
CH. 128	824.2	GPRS 850	883.5	-24.90	hor	-13.00	-11.93	
CH. 188	826.2	GPRS 850	No significant spurious emissions					
CH. 251	848.8	GPRS 850	849.002	-18.50	ver	-13.00	-05.49	
CH. 251	848.8	GPRS 850	849.002	-18.80	hor	-13.00	-05.81	
Test results – GSM1900								
Channel	Frequency [MHz]	Mode	Emission [MHz]	Level [dBm]	Pol.	Limit [dBm]	Margin [dB]	
CH 512	1850.2	GPRS 1900	1850	-22.60	hor	-13.00	-09.65	
CH 512	1850.2	GPRS 1900	1850	-26.50	ver	-13.00	-13.50	
CH 661	1880.0	GPRS 1900	No significant spurious emissions					
CH.810	1909.8	GPRS 1900	1910	-25.70	ver	-13.00	-12.68	
CH 810	1909.8	GPRS 1900	1910	-19.30	hor	-13.00	-06.33	
Comments: after check with 6V DC and 12 V DC spurious measurement with 6 V DC worst case								

3.4 Test Conditions and Results – Receiver radiated emissions

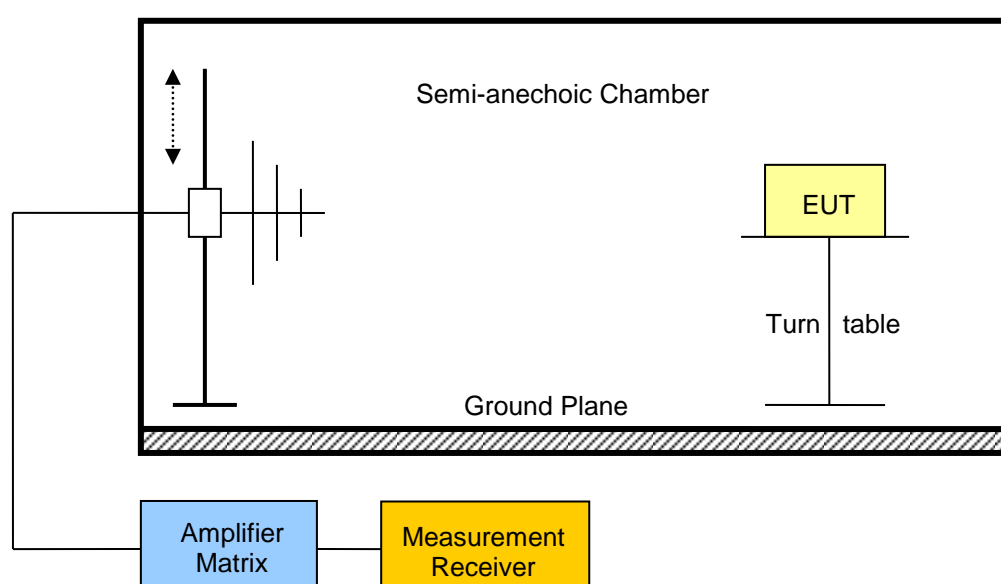
Receiver radiated emissions acc. to IC RSS-210		Verdict: PASS		
Test according referenced standards	Reference Method			
	IC RSS-132 5.6 / 133 6.6			
Test according to measurement reference	Reference Method			
	ANSI C63.4			
Test frequency range	Tested frequencies			
	30 MHz – 5 th Harmonic			
EUT test mode	Receive			
Limits				
Frequency range [MHz]	Detector	Limit [μ V/m]	Limit [dB μ V/m]	Limit Distance [m]
30 – 88	Quasi-Peak	100	40	3
88 – 216	Quasi-Peak	150	43.5	3
216 – 960	Quasi-Peak	200	46	3
960 – 1000	Quasi-Peak	500	54	3
> 1000	Average	500	54	3
Test setup				
				

Test procedure

1. EUT set to receive mode (Communication tester is used if needed)
2. Span it set according to measurement range
3. Resolution bandwidth below 1GHz is set according to CISPR 16 with peak/quasi-peak detector and RBW of 1MHz with peak/average detector is used above 1GHz
4. Markers are set to peak emission levels

Test results GSM 850

Channel	Frequency [MHz]	Emission [MHz]	Emission Level [db μ V/m]	Emission Level [μ V/m]	Det.	Limit [μ V/m]	Margin [μ V/m]
CH 188	836.2	3855	43.17	144.05	pk	500	-355.95
CH 188	836.2	3503	42.56	134.28	pk	500	-365.72

Test results GSM 1900

Channel	Frequency [MHz]	Emission [MHz]	Emission Level [db μ V/m]	Emission Level [μ V/m]	Det.	Limit [μ V/m]	Margin [μ V/m]
CH 661	1880	7032	51.02	355.63	pk	500	-144.37
CH 661	1880	7400	51.52	376.70	pk	500	-123.30

Comments: