



FCC Part 15E Test Report

FCC ID: 2AEKR-TG08RK

| | |
|------------------|---|
| Product Name: | Tablet PC |
| Trademark: | N/A |
| Model Name : | TG08RK TG08RK1, TG08RK2, TG08RK3, TG08RK4, TG08RK5, TG08RK6, TG08RK7, TG08RK8, TG08RK9, M806 |
| Prepared For : | Elitegroup Computer System CO., LTD. |
| Address : | No. 239, Sec. 2 Ti Ding Blvd., Taipei, Taiwan (R.O.C) |
| Prepared By : | Shenzhen BCTC Testing Co., Ltd. |
| Address : | BCTC Building & 1-2F, East of B Building, Pengzhou Industrial, Fuyuan 1st Road, Qiaotou Community, Fuyong Street, Bao'an District, Shenzhen, China |
| Test Date: | May 21, 2019 – May 28, 2019 |
| Date of Report : | May 28, 2019 |
| Report No.: | BCTC-FY190502668-3E |



TEST RESULT CERTIFICATION

Applicant's name : Elitegroup Computer System CO., LTD.
Address : No. 239, Sec. 2 Ti Ding Blvd., Taipei, Taiwan (R.O.C)
Manufacture's Name..... : Shenzhen NST Industry and Trade Co.,Ltd
Address : 3/F, Bldg 1, Hongbang Technology Park, No.30 Cuibao Road,
 Baolong Street, Longgang District, Shenzhen, China

Product description

Product name : Tablet PC
Trademark : N/A

Model and/or type reference : TG08RK
 TG08RK1, TG08RK2, TG08RK3, TG08RK4, TG08RK5,
 TG08RK6, TG08RK7, TG08RK8, TG08RK9, M806

Standards : FCC Part15 15.407
 ANSI C63.10-2013
 KDB 662911 D01 v02r01
 KDB 789033 D02 v01r02

This device described above has been tested by BCTC, and the test results show that the equipment under test (EUT) is in compliance with the FCC requirements. And it is applicable only to the tested sample identified in the report.

This report shall not be reproduced except in full, without the written approval of BCTC, this document may be altered or revised by BCTC, personal only, and shall be noted in the revision of the document.



| | | |
|------------------------|-----------|--|
| Prepared by(Engineer): | Leke Xie |  |
| Reviewer(Supervisor): | Eric Yang |  |
| Approved(Manager): | Zero Zhou |  |





Table of Contents

| | Page |
|--|-----------|
| 1 . SUMMARY OF TEST RESULTS | 7 |
| 1.1 TEST FACILITY | 8 |
| 1.2 MEASUREMENT UNCERTAINTY | 8 |
| 3 . EMC EMISSION TEST | 15 |
| 3.1 CONDUCTED EMISSION MEASUREMENT | 15 |
| 3.1.1 POWER LINE CONDUCTED EMISSION LIMITS | 15 |
| 3.1.2 TEST PROCEDURE | 16 |
| 3.1.3 DEVIATION FROM TEST STANDARD | 16 |
| 3.1.4 TEST SETUP | 16 |
| 3.1.5 EUT OPERATING CONDITIONS | 16 |
| 3.2 RADIATED EMISSION MEASUREMENT | 19 |
| 3.2.1 APPLICABLE STANDARD | 19 |
| 3.2.2 CONFORMANCE LIMIT | 19 |
| 3.2.3 MEASURING INSTRUMENTS | 19 |
| 3.2.4 TEST CONFIGURATION | 20 |
| 3.2.5 TEST PROCEDURE | 21 |
| 3.2.6 TEST RESULTS (9KHZ – 30 MHZ) | 22 |
| 3.2.7 TEST RESULTS (30MHZ – 1GHZ) | 23 |
| 3.2.8 TEST RESULTS (1GHZ-40GHZ) | 25 |
| 4 . POWER SPECTRAL DENSITY TEST | 27 |
| 4.1 APPLIED PROCEDURES / LIMIT | 27 |
| 4.2 TEST PROCEDURE | 28 |
| 4.3 DEVIATION FROM STANDARD | 28 |
| 4.4 TEST SETUP | 28 |
| 4.5 EUT OPERATION CONDITIONS | 28 |
| 4.6 TEST RESULTS | 29 |
| 5 . 26DB & 99% EMISSION BANDWIDTH | 37 |
| 5.1 APPLIED PROCEDURES / LIMIT | 37 |
| 5.2 TEST PROCEDURE | 37 |
| 5.3 EUT OPERATION CONDITIONS | 38 |
| 5.4 TEST RESULTS | 39 |
| 6 . MINIMUM 6 DB BANDWIDTH | 49 |
| 6.1 APPLIED PROCEDURES / LIMIT | 49 |
| 6.2 TEST PROCEDURE | 49 |
| 6.3 DEVIATION FROM STANDARD | 49 |



Table of Contents

| | Page |
|--|-----------|
| 6.4 TEST SETUP | 49 |
| 6.5 EUT OPERATION CONDITIONS | 49 |
| 6.6 TEST RESULTS | 50 |
| 7 . MAXIMUM CONDUCTED OUTPUT POWER | 54 |
| 7.1 PPLIED PROCEDURES / LIMIT | 54 |
| 7.2 TEST PROCEDURE | 54 |
| 7.3 DEVIATION FROM STANDARD | 56 |
| 7.4 TEST SETUP | 56 |
| 7.5 EUT OPERATION CONDITIONS | 56 |
| 7.6 TEST RESULTS | 57 |
| 8 . OUT OF BAND EMISSIONS | 59 |
| 8.1 APPLICABLE STANDARD | 59 |
| 8.2 TEST PROCEDURE | 59 |
| 8.3 DEVIATION FROM STANDARD | 59 |
| 8.4 TEST SETUP | 59 |
| 8.5 EUT OPERATION CONDITIONS | 59 |
| 8.6 TEST RESULTS | 60 |
| 9.SPURIOUS RF CONDUCTED EMISSIONS | 66 |
| 9.1CONFORMANCE LIMIT | 66 |
| 9.2MEASURING INSTRUMENTS | 66 |
| 9.3TEST SETUP | 66 |
| 9.4TEST PROCEDURE | 66 |
| 9.5TEST RESULTS | 66 |
| 10. FREQUENCY STABILITY MEASUREMENT | 81 |
| 10.1 LIMIT | 81 |
| 10.2 TEST PROCEDURES | 81 |
| 10.3 TEST SETUP LAYOUT | 81 |
| 10.4 EUT OPERATION DURING TEST | 81 |
| 10.5 TEST RESULTS | 82 |
| 11. ANTENNA REQUIREMENT | 88 |
| 11.1 STANDARD REQUIREMENT | 88 |
| 11.2 EUT ANTENNA | 88 |
| 12. EUT TEST PHOTO | 89 |



Table of Contents

| | Page |
|---------------|------|
| 13. EUT PHOTO | 92 |



Revision History

| Report No. | Version | Description | Issued Date |
|---------------------|---------|-------------------------|--------------|
| BCTC-FY190502668-3E | Rev.01 | Initial issue of report | May 28, 2019 |
| | | | |
| | | | |
| | | | |
| | | | |
| | | | |
| | | | |
| | | | |
| | | | |
| | | | |
| | | | |
| | | | |
| | | | |
| | | | |
| | | | |
| | | | |
| | | | |
| | | | |



1. SUMMARY OF TEST RESULTS

Test procedures according to the technical standards:

| FCC Part15 (15.407) , Subpart E | | | |
|---|---|----------|--------|
| Standard Section | Test Item | Judgment | Remark |
| 15.209(a), 15.407 (b)(1) 15.407 (b)(4) 15.407 (b)(6) | Spurious Radiated Emissions | PASS | |
| 15.407 (a)(1) 15.407 (a)(3) 15.1049 | 26 dB and 99% Emission Bandwidth | PASS | |
| 15.407(e) | Minimum 6 dB bandwidth | PASS | |
| 15.407 (a)(1) 15.407 (a)(3) | Maximum Conducted Output Power | PASS | |
| 2.1051, 15.407(b)(1) 15.407(b)(4) | Band Edge | PASS | |
| 15.407 (a)(1) 15.407 (a)(3) | Power Spectral Density | PASS | |
| 2.1051, 15.407(b) | Spurious Emissions at Antenna Terminals | PASS | |
| 15.203 | Antenna Requirement | PASS | |

NOTE:

(1) "N/A" denotes test is not applicable in this Test Report

Outsourcing: The 26G-40G Spurious Radiated Emissions in this test were outsourced to the Shenzhen Academy of Metrology & Quality Inspection



1.1 TEST FACILITY

Shenzhen BCTC Testing Co., Ltd.

Add. : BCTC Building & 1-2F, East of B Building, Pengzhou Industrial, Fuyuan 1st Road, Qiaotou Community, Fuyong Street, Bao'an District, Shenzhen, China

FCC Test Firm Registration Number: 712850

IC Registered No.: 23583

1.2 MEASUREMENT UNCERTAINTY

The reported uncertainty of measurement $y \pm U$, where expanded uncertainty U is based on a standard uncertainty multiplied by a coverage factor of $k=2$, providing a level of confidence of approximately 95 %.

| No. | Item | Uncertainty |
|-----|--|-------------|
| 1 | 3m chamber Radiated spurious emission(30MHz-1GHz) | U=4.3dB |
| 2 | 3m chamber Radiated spurious emission(1GHz-18GHz) | U=4.5dB |
| 3 | 3m chamber Radiated spurious emission(18GHz-40GHz) | U=3.34dB |
| 4 | Conducted Adjacent channel power | U=1.38dB |
| 5 | Conducted output power uncertainty Above 1G | U=1.576dB |
| 6 | Conducted output power uncertainty below 1G | U=1.28dB |
| 7 | humidity uncertainty | U=5.3% |
| 8 | Temperature uncertainty | U=0.59℃ |



2. GENERAL INFORMATION

2.1 GENERAL DESCRIPTION OF EUT

| | | | |
|------------------------|--|--|--|
| Equipment | Tablet PC | | |
| Trade Name | N/A | | |
| Model Name | TG08RK TG08RK1, TG08RK2, TG08RK3, TG08RK4, TG08RK5, TG08RK6, TG08RK7, TG08RK8, TG08RK9, M806 | | |
| Model Difference | All the model are the same circuit and RF module, except model names . | | |
| Product Description | IEEE 802.11 WLAN Mode Supported | <input checked="" type="checkbox"/> 802.11a/n/ac(20MHz channel bandwidth) <input type="checkbox"/> 802.11n/ac(40MHz channel bandwidth) <input type="checkbox"/> 802.11ac(80MHz channel bandwidth) | |
| | Data Rate | 802.11a: 6,9,12,18,24,36,48,54Mbps; 802.11n(HT20/HT40):MCS0-MCS15; 802.11ac(VHT20): NSS1, MCS0-MCS8 802.11ac(VHT40/VHT80):NSS1, MCS0-MCS9 | |
| | Modulation | OFDM with BPSK/QPSK/16QAM/64QAM/256QAM for 802.11a/n/ac; | |
| | Operating Frequency Range | <input checked="" type="checkbox"/> 5180-5240MHz for 802.11a/n(HT20)/ac20; 5190-5230MHz for 802.11n(HT40)/ac40; 5210MHz for 802.11 ac80; <input checked="" type="checkbox"/> 5745-5825 MHz for 802.11a/n(HT20)/ac20; 5755-5795 MHz for 802.11a/n(HT40)/ac40; 5775MHz for 802.11 ac80; | |
| | Number of Channels | <input checked="" type="checkbox"/> 4 channels for 802.11a/n20/ac20 in the 5180-5240MHz band ; 2 channels for 802.11 n40/ac40 in the 5190-5230MHz band ; 1 channels for 802.11 ac80 in the 5210MHz band ; <input checked="" type="checkbox"/> 5 channels for 802.11a/n20/ac20 in the 5745-5825MHz band ; 2 channels for 802.11 n40/ac40 in the 5755-5795MHz band ; 1 channels for 802.11 ac80 in the 5775MHz band ; | |
| | Antenna Type | FPCB Antenna | |
| | Antenna Gain | 1dBi | |
| | | | Based on the application, features, or specification exhibited in User's Manual, the EUT is considered as an ITE/Computing Device. More details of EUT technical specification, please refer to the User's Manual. |
| | Channel List | Please refer to the Note 2. | |
| | Ratings | DC 5V From adapter, DC 3.7V For battery | |
| hardware version | H1.0 | | |
| Software version | S1.0 | | |
| Connecting I/O Port(s) | Please refer to the User's Manual | | |

Note:



1. For a more detailed features description, please refer to the manufacturer's specifications or the User's Manual.
2. Frequency and Channel list for 802.11a/n(20MHz) band I (5180-5240MHz):

| 802.11a/n/ac(20MHz) Carrier Frequency Channel | | | | | | | |
|--|-----------------|---------|-----------------|---------|-----------------|---------|-----------------|
| Channel | Frequency (MHz) | Channel | Frequency (MHz) | Channel | Frequency (MHz) | Channel | Frequency (MHz) |
| 36 | 5180 | 44 | 5220 | - | - | - | - |
| 40 | 5200 | 48 | 5240 | - | - | - | - |

| 802.11n /ac(40MHz) Carrier Frequency Channel | | | | | | | |
|--|-----------------|---------|-----------------|---------|-----------------|---------|-----------------|
| Channel | Frequency (MHz) | Channel | Frequency (MHz) | Channel | Frequency (MHz) | Channel | Frequency (MHz) |
| 38 | 5190 | - | - | - | - | - | - |
| 46 | 5230 | - | - | - | - | - | - |

| 802.11ac (80MHz) Carrier Frequency Channel | |
|--|-----------------|
| Channel | Frequency (MHz) |
| 42 | 5210 |

Frequency and Channel list for 802.11a/n(20 MHz) band IV (5745-5825MHz):

| 802.11a/n/ac(20 MHz) Carrier Frequency Channel | | | | | | | |
|---|-----------------|---------|-----------------|---------|-----------------|---------|-----------------|
| Channel | Frequency (MHz) | Channel | Frequency (MHz) | Channel | Frequency (MHz) | Channel | Frequency (MHz) |
| 149 | 5745 | 153 | 5765 | 157 | 5785 | 161 | 5805 |
| 165 | 5825 | - | - | - | - | - | - |

| 802.11n/ac 40MHz Carrier Frequency Channel | | | | | |
|--|-----------------|---------|-----------------|---------|-----------------|
| Channel | Frequency (MHz) | Channel | Frequency (MHz) | Channel | Frequency (MHz) |
| 151 | 5755 | 159 | 5795 | - | - |

| 802.11ac 80MHz Carrier Frequency Channel | |
|--|-----------------|
| Channel | Frequency (MHz) |
| 155 | 5775 |

The EUT has two types of antenna. The wireless module is 1x1 Wi-Fi support 802.11a / n / ac;

Tx Antenna

| Antenna | Antenna Type | Antenna Gain(dBi) |
|---------|--------------|-------------------|
| A(main) | FPCB | 1 |



2.2 DESCRIPTION OF TEST MODES

| Pretest Mode | Description |
|--------------|--|
| Mode 5 | 802.11a / n/ ac 20 CH36/ CH40/ CH 48 802.11a /n/ ac 20 CH149/ CH157/ CH 165 |
| Mode 2 | 802.11n/ ac40 CH38/ CH 46 802.11n/ ac40 CH 151 / CH 159 |
| Mode 3 | 802.11 ac80 CH 42/CH 155 |
| Mode 4 | 802.11a / n/ ac 20 CH36/ CH40/ CH 48 802.11a /n/ ac 20 CH149/ CH157/ CH 165 |
| Mode 5 | Link Mode |

| Conducted Emission | |
|--------------------|-------------|
| Final Test Mode | Description |
| Mode 5 | Link Mode |

| For Radiated Emission | |
|-----------------------|--|
| Final Test Mode | Description |
| Mode 5 | 802.11a / n/ ac 20 CH36/ CH40/ CH 48 802.11a /n/ ac 20 CH149/ CH157/ CH 165 |
| Mode 2 | 802.11n/ ac40 CH38/ CH 46 802.11n/ ac40 CH 151 / CH 159 |
| Mode 3 | 802.11 ac80 CH 42/CH 155 |
| Mode 4 | 802.11a / n/ ac 20 CH36/ CH40/ CH 48 802.11a /n/ ac 20 CH149/ CH157/ CH 165 |

Note:

(1) The measurements are performed at all Bit Rate of Transmitter, the worst data was reported.

2.3 BLOCK DIGRAM SHOWING THE CONFIGURATION OF SYSTEM TESTED

Conducted Emission Test

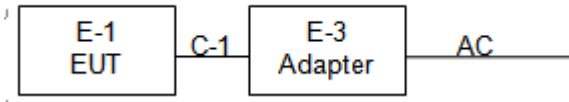

Radiated Spurious Emission

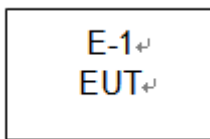

2.4 DESCRIPTION OF SUPPORT UNITS(CONDUCTED MODE)

The EUT has been tested as an independent unit together with other necessary accessories or support units. The following support units or accessories were used to form a representative test configuration during the tests.

| | Device Type | Brand | Model | Series No. | Data Cable |
|-----|-------------|-------|---------|------------|------------|
| E-1 | Tablet PC | N/A | TG80RK | N/A | EUT |
| E-2 | Adapter | N/A | BCTC005 | N/A | Auxiliary |

| Item | Shielded Type | Ferrite Core | Length | Note |
|------|---------------|--------------|--------|---------------------|
| C-1 | NO | NO | 0.8M | DC cable unshielded |

Note:

- (1) The support equipment was authorized by Declaration of Confirmation.
- (2) For detachable type I/O cable should be specified the length in cm in 『Length』 column.



2.5 EQUIPMENTS LIST FOR ALL TEST ITEMS

Radiation Test equipment

| Item | Equipment | Manufacturer | Type No. | Serial No. | Last calibration | Calibrated until |
|------|----------------------------------|--------------|---------------|---------------|------------------|------------------|
| 1 | Spectrum Analyzer (9kHz-26.5GHz) | Agilent | E4407B | MY45109572 | 2018.06.20 | 2019.06.20 |
| 2 | Test Receiver (9kHz-7GHz) | R&S | ESR7 | 101154 | 2018.06.20 | 2019.06.20 |
| 3 | Bilog Antenna (30MHz-3GHz) | SCHWARZBECK | VULB9163 | VULB9163-942 | 2018.06.23 | 2019.06.23 |
| 4 | Horn Antenna (1GHz-18GHz) | SCHWARZBECK | BBHA9120D | 1541 | 2018.06.23 | 2021.06.22 |
| 5 | Horn Antenna (18GHz-40GHz) | SCHWARZBECK | BBHA9170 | 822 | 2018.08.06 | 2019.08.06 |
| 6 | Amplifier (9KHz-6GHz) | SCHWARZBECK | BBV9744 | 9744-0037 | 2018.06.20 | 2019.06.20 |
| 7 | Amplifier (0.5GHz-18GHz) | SCHWARZBECK | BBV9718 | 9718-309 | 2018.06.20 | 2019.06.20 |
| 8 | Amplifier (18GHz-40GHz) | MITEQ | TTA1840-35-HG | 2034381 | 2018.08.06 | 2019.08.06 |
| 9 | Loop Antenna (9KHz-30MHz) | SCHWARZBECK | FMZB1519B | 014 | 2018.06.23 | 2019.06.23 |
| 10 | RF cables1 (9kHz-30MHz) | Huber+Suhnar | 9kHz-30MHz | B1702988-0008 | 2019.02.12 | 2020.02.12 |
| 11 | RF cables2 (30MHz-1GHz) | Huber+Suhnar | 30MHz-1GHz | 1486150 | 2019.03.27 | 2020.03.27 |
| 12 | RF cables3 (1GHz-40GHz) | Huber+Suhnar | 1GHz-40GHz | 1607106 | 2018.06.19 | 2019.06.19 |
| 13 | Power Metter | Keysight | E4419 | \ | 2018.06.15 | 2019.06.15 |
| 14 | Power Sensor (AV) | Keysight | E9 300A | \ | 2018.06.15 | 2019.06.15 |
| 15 | Signal Analyzer 20kHz-26.5GHz | KEYSIGHT | N9020A | MY49100060 | 2018.08.14 | 2019.08.13 |
| 16 | Test Receiver 9kHz-40GHz | R&S | FSP40 | 100550 | 2018.06.13 | 2019.06.12 |
| 17 | D.C. Power Supply | LongWei | TPR-6405D | \ | \ | \ |
| 18 | Software | Frad | EZ-EMC | FA-03A2 RE | \ | \ |



Conduction Test equipment

| Item | Equipment | Manufacturer | Type No. | Serial No. | Last calibration | Calibrated until |
|------|---------------|-----------------|------------|-------------------|------------------|------------------|
| 1 | Test Receiver | R&S | ESR3 | 102075 | 2018.06.20 | 2019.06.20 |
| 2 | LISN | SCHWARZBEC K | NSLK8127 | 8127739 | 2018.06.19 | 2019.06.19 |
| 3 | LISN | R&S | ENV216 | 101375 | 2018.06.20 | 2019.06.20 |
| 4 | RF cables | Huber+Suhnar | 9kHz-30MHz | B1702988-00 08 | 2019.02.12 | 2020.02.12 |
| 5 | Software | Frad | EZ-EMC | EMC-CON 3A1 | \ | \ |



3. EMC EMISSION TEST

3.1 CONDUCTED EMISSION MEASUREMENT

3.1.1 POWER LINE CONDUCTED EMISSION Limits (Frequency Range 150KHz-30MHz)

| FREQUENCY (MHz) | Class B (dBuV) | | Standard |
|-----------------|----------------|-----------|----------|
| | Quasi-peak | Average | |
| 0.15 -0.5 | 66 - 56 * | 56 - 46 * | CISPR |
| 0.50 -5.0 | 56.00 | 46.00 | CISPR |
| 5.0 -30.0 | 60.00 | 50.00 | CISPR |

| | | | |
|-----------|-----------|-----------|-----------------|
| 0.15 -0.5 | 66 - 56 * | 56 - 46 * | FCC/ RSS-247 |
| 0.50 -5.0 | 56.00 | 46.00 | FCC/ RSS-247 |
| 5.0 -30.0 | 60.00 | 50.00 | FCC/ RSS-247 |

Note:

- (1) The tighter limit applies at the band edges.
- (2) The limit of " * " marked band means the limitation decreases linearly with the logarithm of the frequency in the range.

The following table is the setting of the receiver

| Receiver Parameters | Setting |
|---------------------|----------|
| Attenuation | 10 dB |
| Start Frequency | 0.15 MHz |
| Stop Frequency | 30 MHz |
| IF Bandwidth | 9 kHz |

3.1.2 TEST PROCEDURE

- a. The EUT was placed 0.8 meters from the horizontal ground plane with EUT being connected to the power mains through a line impedance stabilization network (LISN). All other support equipments powered from additional LISN(s). The LISN provide 50 Ohm/ 50uH of coupling impedance for the measuring instrument.
- b. Interconnecting cables that hang closer than 40 cm to the ground plane shall be folded back and forth in the center forming a bundle 30 to 40 cm long.
- c. I/O cables that are not connected to a peripheral shall be bundled in the center. The end of the cable may be terminated, if required, using the correct terminating impedance. The overall length shall not exceed 1 m.
- d. LISN at least 80 cm from nearest part of EUT chassis.
- e. For the actual test configuration, please refer to the related Item –EUT Test Photos.

3.1.3 DEVIATION FROM TEST STANDARD

No deviation

3.1.4 TEST SETUP

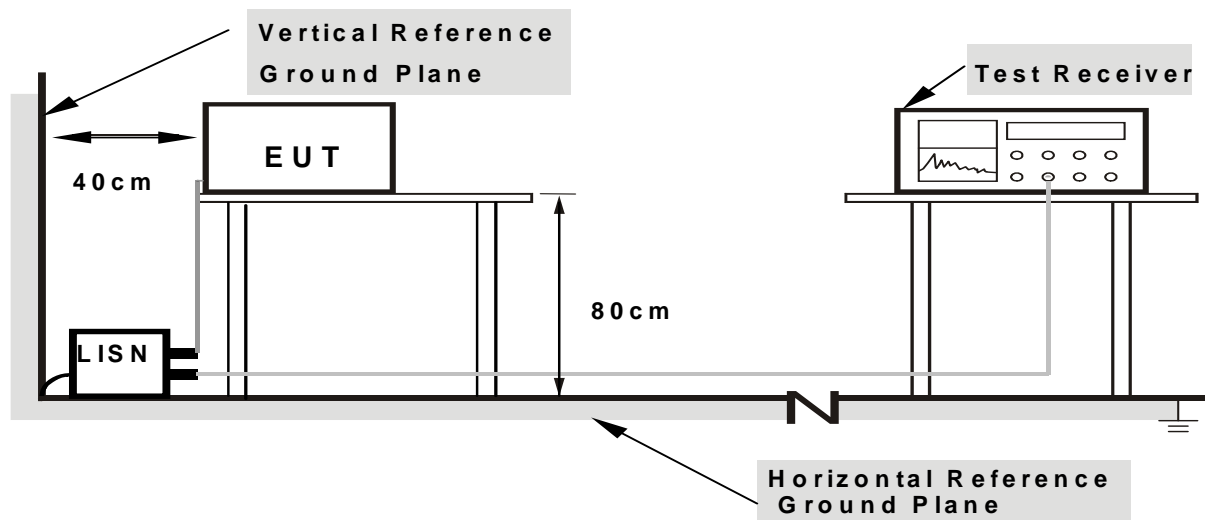

Note: 1. Support units were connected to second LISN.

2. Both of LISNs (AMN) are 80 cm from EUT and at least 80 cm from other units and other metal planes

3.1.5 EUT OPERATING CONDITIONS

The EUT was configured for testing in a typical fashion (as a customer would normally use it). The EUT has been programmed to continuously transmit during test. This operating condition was tested and used to collect the included data.



| | | | |
|----------------|-------------|---------------------|--------|
| Temperature : | 26 °C | Relative Humidity : | 54% |
| Pressure : | 101kPa | Phase : | L |
| Test Voltage : | AC120V 60Hz | Test Mode : | Mode 5 |

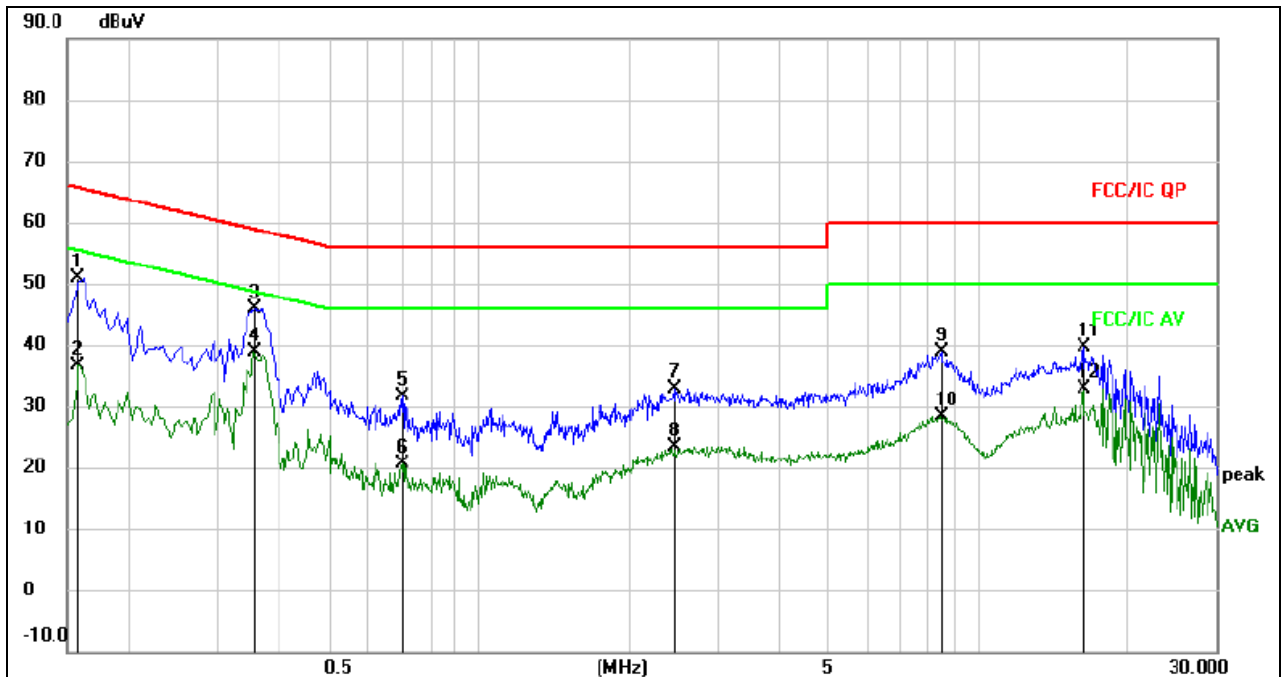

Remark:

1. All readings are Quasi-Peak and Average values.
2. Factor = Insertion Loss + Cable Loss.

| No. | Mk. | Freq. MHz | Reading Level dBuV | Correct Factor | Measure- ment dBuV | Limit dBuV | Over dB | Detector | Comment |
|-----|-----|--------------|--------------------------|-------------------|--------------------------|---------------|------------|----------|---------|
| 1 | | 0.1580 | 41.26 | 9.51 | 50.77 | 65.57 | -14.80 | QP | |
| 2 | | 0.1580 | 27.12 | 9.51 | 36.63 | 55.57 | -18.94 | AVG | |
| 3 | | 0.3540 | 36.45 | 9.54 | 45.99 | 58.87 | -12.88 | QP | |
| 4 | * | 0.3540 | 29.45 | 9.54 | 38.99 | 48.87 | -9.88 | AVG | |
| 5 | | 0.7019 | 21.87 | 9.65 | 31.52 | 56.00 | -24.48 | QP | |
| 6 | | 0.7019 | 11.00 | 9.65 | 20.65 | 46.00 | -25.35 | AVG | |
| 7 | | 2.4700 | 23.25 | 9.62 | 32.87 | 56.00 | -23.13 | QP | |
| 8 | | 2.4700 | 13.88 | 9.62 | 23.50 | 46.00 | -22.50 | AVG | |
| 9 | | 8.4060 | 29.05 | 9.71 | 38.76 | 60.00 | -21.24 | QP | |
| 10 | | 8.4060 | 18.70 | 9.71 | 28.41 | 50.00 | -21.59 | AVG | |
| 11 | | 16.2300 | 29.87 | 9.72 | 39.59 | 60.00 | -20.41 | QP | |
| 12 | | 16.2300 | 23.17 | 9.72 | 32.89 | 50.00 | -17.11 | AVG | |



| | | | |
|----------------|-------------|---------------------|--------|
| Temperature : | 26 °C | Relative Humidity : | 54% |
| Pressure : | 101kPa | Phase : | N |
| Test Voltage : | AC120V 60Hz | Test Mode : | Mode 5 |

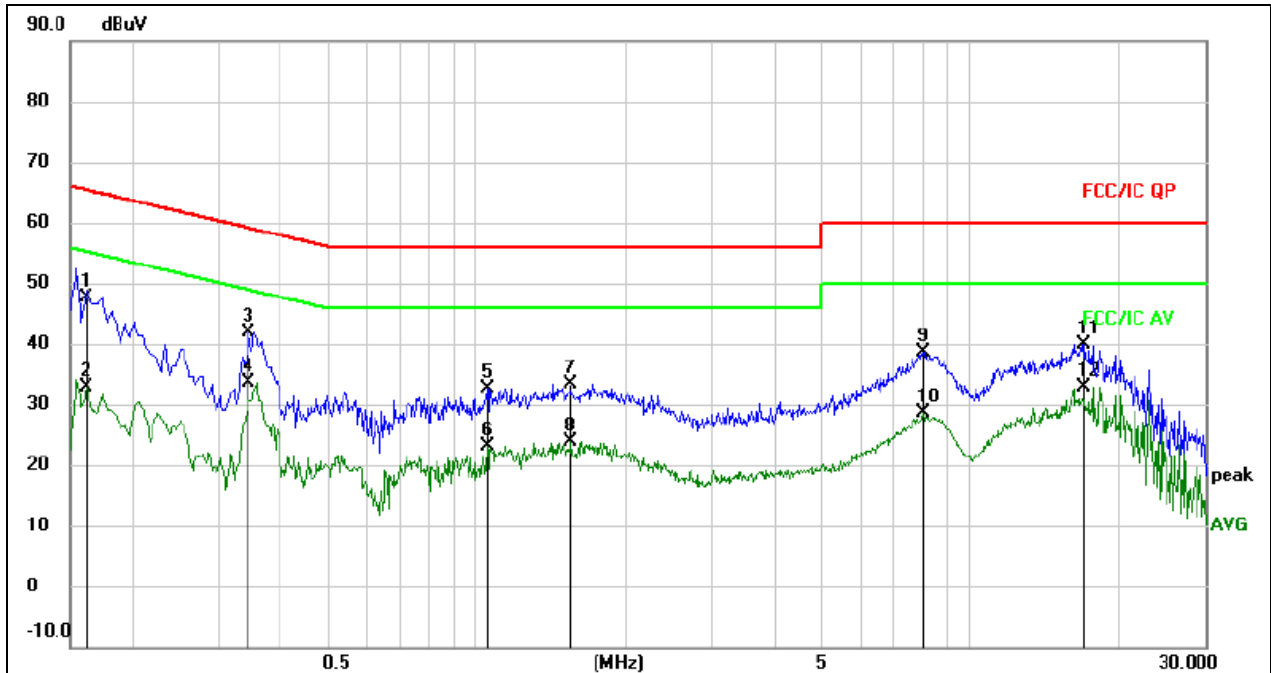

Remark:

- All readings are Quasi-Peak and Average values.
- Factor = Insertion Loss + Cable Loss.

| No. | Mk. | Freq. MHz | Reading Level dBuV | Correct Factor | Measure- ment dBuV | Limit dBuV | Over dB | Detector | Comment |
|-----|-----|--------------|--------------------------|-------------------|--------------------------|---------------|------------|----------|---------|
| 1 | | 0.1620 | 38.07 | 9.51 | 47.58 | 65.36 | -17.78 | QP | |
| 2 | | 0.1620 | 23.46 | 9.51 | 32.97 | 55.36 | -22.39 | AVG | |
| 3 | | 0.3460 | 32.28 | 9.54 | 41.82 | 59.06 | -17.24 | QP | |
| 4 | * | 0.3460 | 24.00 | 9.54 | 33.54 | 49.06 | -15.52 | AVG | |
| 5 | | 1.0540 | 23.04 | 9.57 | 32.61 | 56.00 | -23.39 | QP | |
| 6 | | 1.0540 | 13.64 | 9.57 | 23.21 | 46.00 | -22.79 | AVG | |
| 7 | | 1.5540 | 23.78 | 9.58 | 33.36 | 56.00 | -22.64 | QP | |
| 8 | | 1.5540 | 14.37 | 9.58 | 23.95 | 46.00 | -22.05 | AVG | |
| 9 | | 8.0460 | 29.01 | 9.71 | 38.72 | 60.00 | -21.28 | QP | |
| 10 | | 8.0460 | 18.92 | 9.71 | 28.63 | 50.00 | -21.37 | AVG | |
| 11 | | 17.0860 | 30.22 | 9.74 | 39.96 | 60.00 | -20.04 | QP | |
| 12 | | 17.0860 | 23.20 | 9.74 | 32.94 | 50.00 | -17.06 | AVG | |



3.2 RADIATED EMISSION MEASUREMENT

3.2.1 APPLICABLE STANDARD

According to FCC Part 15.407(d) and 15.209

3.2.2 CONFORMANCE LIMIT

According to FCC Part 15.407(b)(7): radiated emissions which fall in the restricted bands, as defined in §15.205(a), must also comply with the radiated emission limits specified in §15.209(a) (see §15.205(c)).
According to FCC Part 15.205, Restricted bands

| MHz | MHz | MHz | GHz |
|-------------------|---------------------|---------------|-------------|
| 0.090-0.110 | 16.42-16.423 | 399.9-410 | 4.5-5.15 |
| 10.495-0.505 | 16.69475-16.69525 | 608-614 | 5.35-5.46 |
| 2.1735-2.1905 | 16.80425-16.80475 | 960-1240 | 7.25-7.75 |
| 4.125-4.128 | 25.5-25.67 | 1300-1427 | 8.025-8.5 |
| 4.17725-4.17775 | 37.5-38.25 | 1435-1626.5 | 9.0-9.2 |
| 4.20725-4.20775 | 73-74.6 | 1645.5-1646.5 | 9.3-9.5 |
| 6.215-6.218 | 74.8-75.2 | 1660-1710 | 10.6-12.7 |
| 6.26775-6.26825 | 123-138 | 2200-2300 | 14.47-14.5 |
| 8.291-8.294 | 149.9-150.05 | 2310-2390 | 15.35-16.2 |
| 8.362-8.366 | 156.52475-156.52525 | 2483.5-2500 | 17.7-21.4 |
| 8.37625-8.38675 | 156.7-156.9 | 2690-2900 | 22.01-23.12 |
| 8.41425-8.41475 | 162.0125-167.17 | 3260-3267 | 23.6-24.0 |
| 12.29-12.293 | 167.72-173.2 | 3332-3339 | 31.2-31.8 |
| 12.51975-12.52025 | 240-285 | 3345.8-3358 | 36.43-36.5 |
| 12.57675-12.57725 | 322-335.4 | 3600-4400 | (2) |
| 13.36-13.41 | | | |

20dBc in any 100 kHz bandwidth outside the operating frequency band. In case the emission fall within the restricted band specified on 15.205(a), then the 15.209(a) limit in the table below has to be followed.

| Restricted Frequency(MHz) | Field Strength (μV/m) | Field Strength (dBμV/m) | Measurement Distance |
|---------------------------|-----------------------|-------------------------|----------------------|
| 0.009~0.490 | 2400/F(KHz) | 20 log (uV/m) | 300 |
| 0.490~1.705 | 2400/F(KHz) | 20 log (uV/m) | 30 |
| 1.705~30.0 | 30 | 29.5 | 30 |
| 30-88 | 100 | 40 | 3 |
| 88-216 | 150 | 43.5 | 3 |
| 216-960 | 200 | 46 | 3 |
| Above 960 | 500 | 54 | 3 |

Limits of Radiated Emission Measurement(Above 1000MHz)

| Frequency(MHz) | Class B (dBuV/m) (at 3M) | |
|----------------|--------------------------|---------|
| | PEAK | AVERAGE |
| Above 1000 | 74 | 54 |

Remark :1. Emission level in dBuV/m=20 log (uV/m)

2. Measurement was performed at an antenna to the closed point of EUT distance of meters.

3. Distance extrapolation factor =40log(Specific distance/ test distance)(dB);

Limit line=Specific limits(dBuV) + distance extrapolation factor.

3.2.3 MEASURING INSTRUMENTS

The Measuring equipment is listed in the section 6.3 of this test report.

3.2.4 TEST CONFIGURATION

(a) For radiated emissions below 30MHz

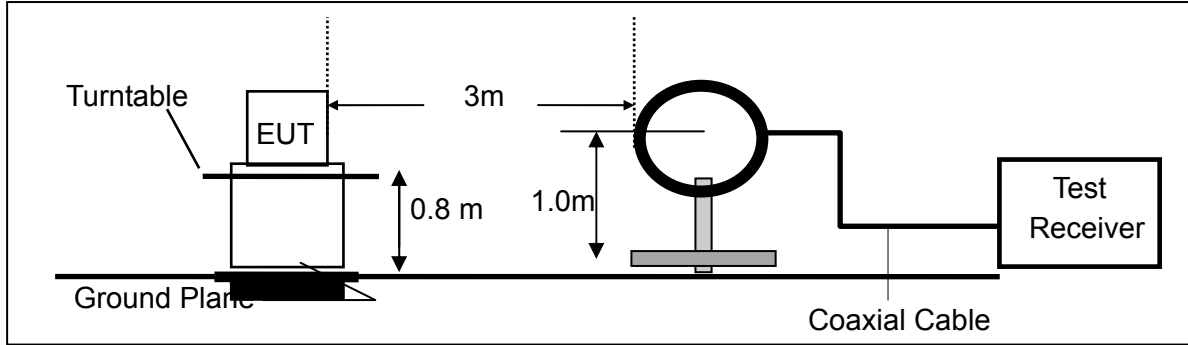

(b) For radiated emissions from 30MHz to 1000MHz

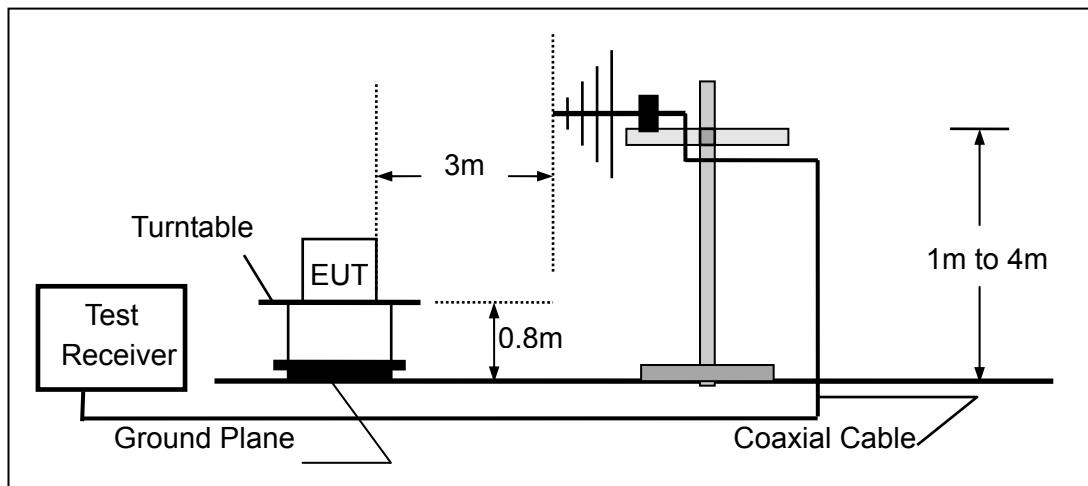

(c) For radiated emissions above 1000MHz

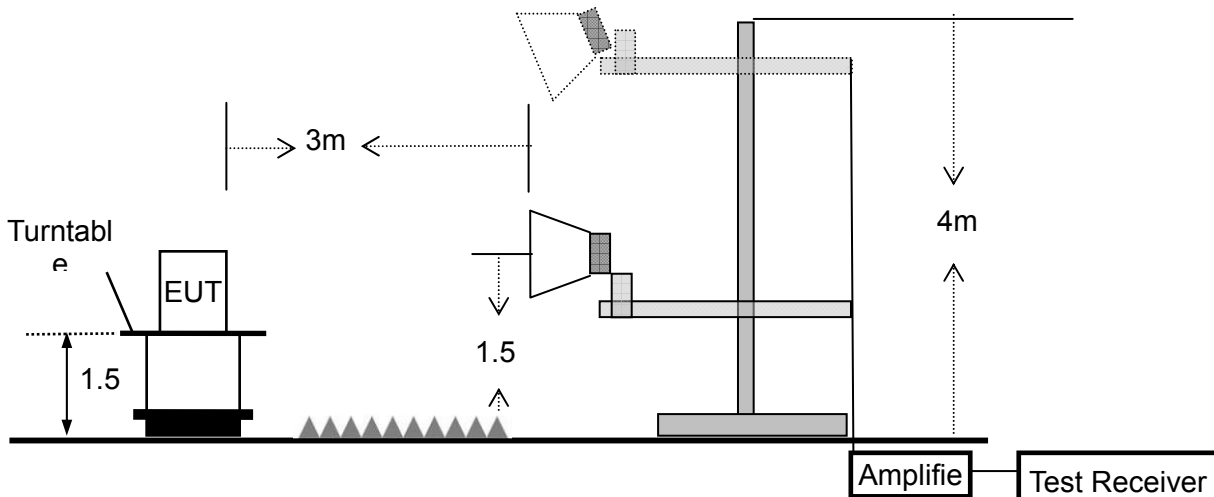



3.2.5 TEST PROCEDURE

The test site semi-anechoic chamber has met the requirement of NSA tolerance 4 dB according to the standards: ANSI C63.10-2013. The test distance is 3m. The setup is according to the requirements in Section 13.1.4.1 of ANSI C63.10-2013 and CAN/CSA-CEI/IEC CISPR 22.

This test is required for any spurious emission that falls in a Restricted Band, as defined in Section 15.205. It must be performed with the highest gain of each type of antenna proposed for use with the EUT.

Use the following spectrum analyzer settings:

| Spectrum Parameter | Setting |
|---------------------------------------|--|
| Attenuation | Auto |
| Start Frequency | 1000 MHz |
| Stop Frequency | 10th carrier harmonic |
| RB / VB (emission in restricted band) | 1 MHz / 1 MHz for Peak, 1 MHz / 10Hz for Average |

| Receiver Parameter | Setting |
|------------------------|----------------------------------|
| Attenuation | Auto |
| Start ~ Stop Frequency | 9kHz~150kHz / RB 200Hz for QP |
| Start ~ Stop Frequency | 150kHz~30MHz / RB 9kHz for QP |
| Start ~ Stop Frequency | 30MHz~1000MHz / RB 120kHz for QP |

- The measuring distance of at 3 m shall be used for measurements at frequency up to 1GHz. For frequencies above 1GHz, any suitable measuring distance may be used.
- The EUT was placed on the top of a rotating table 0.8 m for below 1GHz and 1.5m for above 1GHz the ground at a 3 meter. The table was rotated 360 degrees to determine the position of the highest radiation.
- The height of the equipment or of the substitution antenna shall be 0.8 m for below 1GHz and 1.5m for above 1GHz; the height of the test antenna shall vary between 1 m to 4 m. Both horizontal and vertical polarizations of the antenna are set to make the measurement.
- The initial step in collecting conducted emission data is a spectrum analyzer peak detector mode pre-scanning the measurement frequency range. Significant peaks are then marked and then Quasi Peak detector mode re-measured.
- If the Peak Mode measured value compliance with and lower than Quasi Peak Mode Limit, the EUT shall be deemed to meet QP Limits and then no additional QP Mode measurement performed.
- For the actual test configuration, please refer to the related Item –EUT Test Photos.

Note:

Both horizontal and vertical antenna polarities were tested and performed pretest to three orthogonal axis. The worst case emissions were reported

During the radiated emission test, the Spectrum Analyzer was set with the following configurations:

| Frequency Band (MHz) | Function | Resolution bandwidth | Video Bandwidth |
|----------------------|----------|----------------------|-----------------|
| 30 to 1000 | QP | 120 kHz | 300 kHz |
| Above 1000 | Peak | 1 MHz | 1 MHz |
| | Average | 1 MHz | 10 Hz |

Note: for the frequency ranges below 30 MHz, a narrower RBW is used for these ranges but the measured value should add a RBW correction factor (RBWCF) where $RBWCF [dB] = 10 * \lg(100 [kHz] / \text{narrower RBW [kHz]})$. , the narrower RBW is 1 kHz and RBWCF is 20 dB for the frequency 9 kHz to 150 kHz, and the narrower RBW is 10 kHz and RBWCF is 10 dB for the frequency 150 kHz to 30 MHz.



3.2.6 TEST RESULTS (9KHZ – 30 MHZ)

| | | | |
|--------------|--------|--------------------|---------|
| Temperature: | 26℃ | Relative Humidity: | 54% |
| Pressure: | 101kPa | Test Voltage : | DC 3.7V |
| Test Mode : | Mode 5 | Polarization : | -- |

| Freq. | Reading | Limit | Margin | State |
|-------|----------|----------|--------|-------|
| (MHz) | (dBuV/m) | (dBuV/m) | (dB) | P/F |
| -- | -- | -- | -- | N/A |
| -- | -- | -- | -- | N/A |

NOTE:

The amplitude of spurious emissions which are attenuated by more than 20dB below the permissible value has no need to be reported.

Distance extrapolation factor = 40 log (specific distance/test distance)(dB);

Limit line = specific limits(dBuv) + distance extrapolation factor.



3.2.7 TEST RESULTS (30MHZ – 1GHZ)

| | | | |
|----------------|---------|---------------------|------------|
| Temperature : | 26℃ | Relative Humidity : | 54% |
| Pressure : | 101 kPa | Polarization : | Horizontal |
| Test Voltage : | DC 3.7V | | |
| Test Mode : | Mode 5 | | |

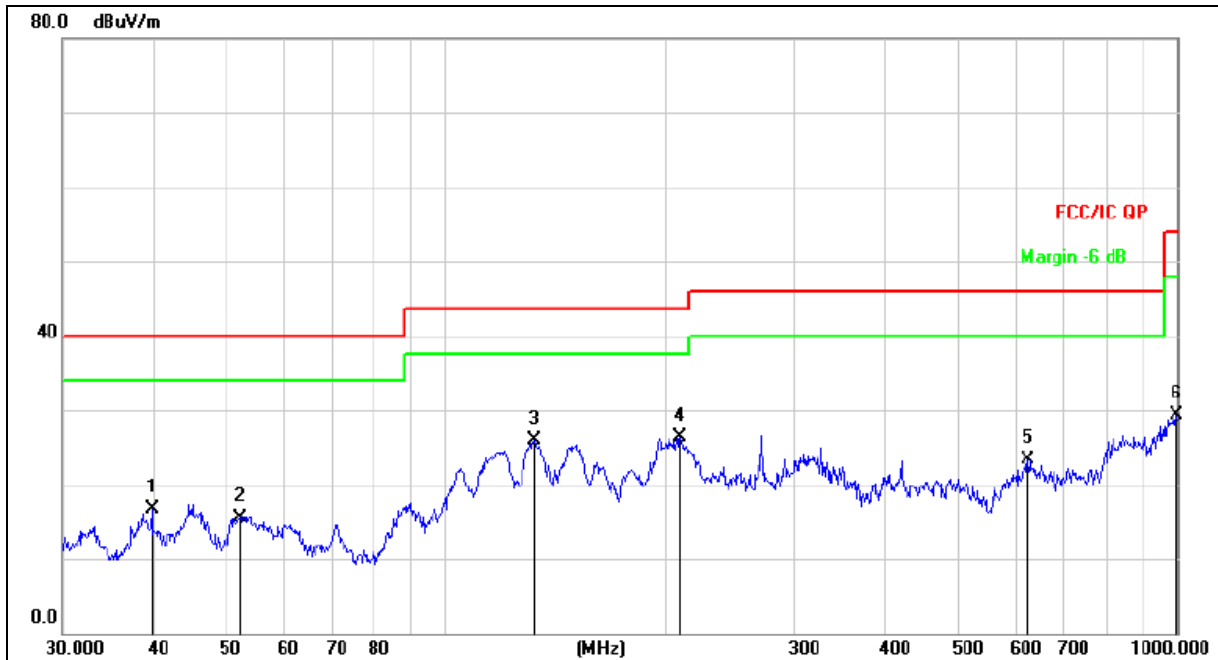

Remark:
Factor = Antenna Factor + Cable Loss – Pre-amplifier.

| No. | Mk. | Freq. MHz | Reading Level dBuV | Correct Factor dB | Measure- ment dBuV/m | Limit dB/m | Over dB | Detector |
|-----|-----|--------------|--------------------------|-------------------------|----------------------------|---------------|------------|----------|
| 1 | | 39.7146 | 31.60 | -14.83 | 16.77 | 40.00 | -23.23 | QP |
| 2 | | 52.3912 | 29.94 | -14.35 | 15.59 | 40.00 | -24.41 | QP |
| 3 | | 132.2206 | 45.06 | -19.15 | 25.91 | 43.50 | -17.59 | QP |
| 4 | * | 209.3129 | 42.58 | -16.23 | 26.35 | 43.50 | -17.15 | QP |
| 5 | | 625.0780 | 29.76 | -6.49 | 23.27 | 46.00 | -22.73 | QP |
| 6 | | 996.4996 | 30.89 | -1.60 | 29.29 | 54.00 | -24.71 | QP |



| | | | |
|----------------|---------|---------------------|----------|
| Temperature : | 26°C | Relative Humidity : | 54% |
| Pressure : | 101kPa | Polarization : | Vertical |
| Test Voltage : | DC 3.7V | | |
| Test Mode : | Mode 5 | | |

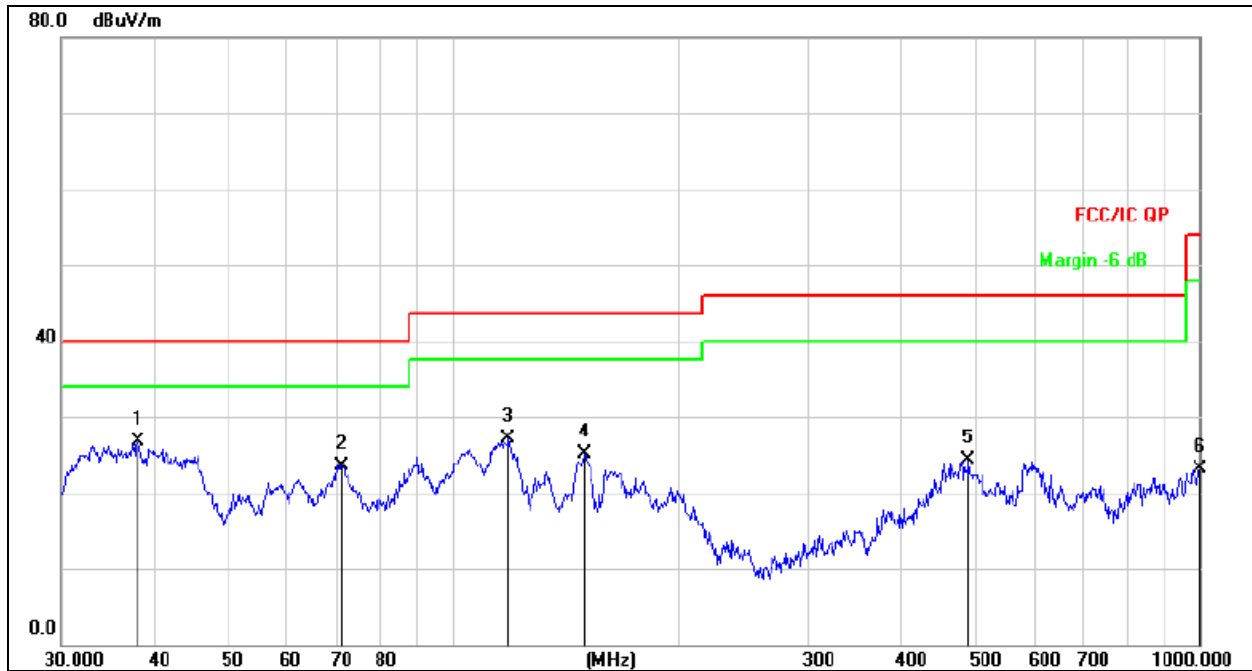

Remark:
Factor = Antenna Factor + Cable Loss – Pre-amplifier.

| No. | Mk. | Freq. MHz | Reading Level dBuV | Correct Factor dB | Measure- ment dBuV/m | Limit dB/m | Over dB | Detector |
|-----|-----|--------------|--------------------------|-------------------------|----------------------------|---------------|------------|----------|
| 1 | * | 37.9450 | 42.11 | -15.45 | 26.66 | 40.00 | -13.34 | QP |
| 2 | | 71.0803 | 41.38 | -17.81 | 23.57 | 40.00 | -16.43 | QP |
| 3 | | 119.0180 | 44.41 | -17.28 | 27.13 | 43.50 | -16.37 | QP |
| 4 | | 150.0108 | 44.00 | -18.97 | 25.03 | 43.50 | -18.47 | QP |
| 5 | | 490.7447 | 34.11 | -9.76 | 24.35 | 46.00 | -21.65 | QP |
| 6 | | 1000.000 | 24.61 | -1.54 | 23.07 | 54.00 | -30.93 | QP |



3.2.8 TEST RESULTS (1GHz-40GHz)

| | |
|-------------|--------------------|
| Test Mode : | TX(5.2G) - 802.11a |
|-------------|--------------------|

| Polar | Frequency | Meter Reading | Cable loss | Antenna Factor | Preamp Factor | Emission Level | Limits | Margin | Detector Type |
|------------------------------------|-----------|---------------|------------|----------------|---------------|----------------|----------|--------|---------------|
| (H/V) | (MHz) | (dBuV) | (dB) | dB/m | (dB) | (dBuV/m) | (dBuV/m) | (dB) | |
| Low Channel (5180 MHz)-Above 1G | | | | | | | | | |
| Vertical | 4434.157 | 62.21 | 5.94 | 35.40 | 44.00 | 59.55 | 74.00 | -14.45 | Pk |
| Vertical | 4434.157 | 46.53 | 5.94 | 35.40 | 44.00 | 43.87 | 54.00 | -10.13 | AV |
| Vertical | 10370.362 | 60.42 | 8.46 | 39.75 | 44.50 | 64.13 | 74.00 | -9.87 | Pk |
| Vertical | 10370.362 | 42.96 | 8.46 | 39.75 | 44.50 | 46.67 | 54.00 | -7.33 | AV |
| Vertical | 15540.196 | 61.42 | 10.12 | 38.80 | 44.10 | 66.24 | 74.00 | -7.76 | Pk |
| Vertical | 15540.196 | 37.52 | 10.12 | 38.80 | 42.70 | 43.74 | 54.00 | -10.26 | AV |
| Horizontal | 4434.521 | 66.53 | 5.94 | 35.18 | 44.00 | 63.65 | 74.00 | -10.35 | Pk |
| Horizontal | 4434.521 | 44.15 | 5.94 | 35.18 | 44.00 | 41.27 | 54.00 | -12.73 | AV |
| Horizontal | 10370.623 | 58.92 | 8.46 | 38.71 | 44.50 | 61.59 | 74.00 | -12.41 | Pk |
| Horizontal | 10370.623 | 41.06 | 8.46 | 38.71 | 44.50 | 43.73 | 54.00 | -10.27 | AV |
| Horizontal | 10540.865 | 56.92 | 10.12 | 38.38 | 44.10 | 61.32 | 74.00 | -12.68 | Pk |
| Horizontal | 10540.865 | 38.88 | 10.12 | 38.38 | 44.10 | 43.28 | 54.00 | -10.72 | AV |
| middle Channel (5200 MHz)-Above 1G | | | | | | | | | |
| Vertical | 4592.093 | 60.23 | 6.48 | 36.35 | 44.05 | 59.01 | 74.00 | -14.99 | Pk |
| Vertical | 4592.093 | 41.98 | 6.48 | 36.35 | 44.05 | 40.76 | 54.00 | -13.24 | AV |
| Vertical | 10401.424 | 59.62 | 8.47 | 37.88 | 44.51 | 61.46 | 74.00 | -12.54 | Pk |
| Vertical | 10401.424 | 42.77 | 8.47 | 37.88 | 44.51 | 44.61 | 54.00 | -9.39 | AV |
| Vertical | 15600.218 | 56.52 | 10.12 | 38.8 | 44.10 | 61.34 | 74.00 | -12.66 | Pk |
| Vertical | 15600.218 | 36.64 | 10.12 | 38.8 | 42.70 | 42.86 | 54.00 | -11.14 | AV |
| Horizontal | 4592.691 | 59.83 | 6.48 | 36.37 | 44.05 | 58.63 | 74.00 | -15.37 | Pk |
| Horizontal | 4592.691 | 43.13 | 6.48 | 36.37 | 44.05 | 41.93 | 54.00 | -12.07 | AV |
| Horizontal | 10400.114 | 58.85 | 8.47 | 38.64 | 44.50 | 61.46 | 74.00 | -12.54 | Pk |
| Horizontal | 10400.114 | 42.24 | 8.47 | 38.64 | 44.50 | 44.85 | 54.00 | -9.15 | AV |
| Horizontal | 15600.187 | 59.82 | 10.12 | 38.38 | 44.10 | 64.22 | 74.00 | -9.78 | Pk |
| Horizontal | 15600.187 | 38.78 | 10.12 | 38.38 | 44.10 | 43.18 | 54.00 | -10.82 | AV |
| High Channel (5240 MHz)-Above 1G | | | | | | | | | |
| Vertical | 4739.246 | 61.23 | 7.10 | 37.24 | 43.50 | 62.07 | 74.00 | -11.93 | Pk |
| Vertical | 4739.246 | 44.41 | 7.10 | 37.24 | 43.50 | 45.25 | 54.00 | -8.75 | AV |
| Vertical | 10480.371 | 60.52 | 8.46 | 37.68 | 44.50 | 62.16 | 74.00 | -11.84 | Pk |
| Vertical | 10480.371 | 40.37 | 8.46 | 37.68 | 44.50 | 42.01 | 54.00 | -11.99 | AV |
| Vertical | 15720.359 | 61.74 | 10.12 | 38.8 | 44.10 | 66.56 | 74.00 | -7.44 | Pk |
| Vertical | 15720.359 | 39.68 | 10.12 | 38.8 | 42.70 | 45.9 | 54.00 | -8.1 | AV |
| Horizontal | 4739.352 | 62.24 | 7.10 | 37.24 | 43.50 | 63.08 | 74.00 | -10.92 | Pk |
| Horizontal | 4739.352 | 43.27 | 7.10 | 37.24 | 43.50 | 44.11 | 54.00 | -9.89 | AV |
| Horizontal | 10481.111 | 62.55 | 8.46 | 38.57 | 44.50 | 65.08 | 74.00 | -8.92 | Pk |
| Horizontal | 10481.111 | 43.32 | 8.46 | 38.57 | 44.50 | 45.85 | 54.00 | -8.15 | AV |
| Horizontal | 15720.357 | 60.74 | 10.12 | 38.38 | 44.10 | 65.14 | 74.00 | -8.86 | Pk |
| Horizontal | 15720.357 | 42.21 | 10.12 | 38.38 | 44.10 | 46.61 | 54.00 | -7.39 | AV |

Note:"802.11n20(5G)" mode is the worst mode. PK value is lower than the Average value limit, So average didn't record.

The amplitude of spurious emissions that are attenuated by more than 20dB below the permissible value has no need to be reported.

Emission level (dBuV/m) = 20 log Emission level (uV/m).

Corrected Reading: Antenna Factor + Cable Loss + Read Level - Preamp Factor = Level.



| | |
|-------------|----------------------|
| Test Mode : | TX (5.8G) -- 802.11a |
|-------------|----------------------|

| Polar | Frequency | Meter Reading | Cable loss | Antenna Factor | Preamp Factor | Emission Level | Limits | Margin | Detector Type |
|------------------------------------|-----------|---------------|------------|----------------|---------------|----------------|----------|--------|---------------|
| (H/V) | (MHz) | (dBuV) | (dB) | dB/m | (dB) | (dBuV/m) | (dBuV/m) | (dB) | |
| Low Channel (5745 MHz)-Above 1G | | | | | | | | | |
| Vertical | 4679.195 | 59.93 | 5.94 | 35.40 | 44.00 | 57.27 | 74.00 | -16.73 | Pk |
| Vertical | 4679.195 | 39.67 | 5.94 | 35.40 | 44.00 | 37.01 | 54.00 | -16.99 | AV |
| Vertical | 11490.364 | 59.55 | 8.46 | 39.75 | 44.50 | 63.26 | 74.00 | -10.74 | Pk |
| Vertical | 11490.364 | 42.16 | 8.46 | 39.75 | 44.50 | 45.87 | 54.00 | -8.13 | AV |
| Vertical | 17235.101 | 55.53 | 10.12 | 38.80 | 44.10 | 60.35 | 74.00 | -13.65 | Pk |
| Vertical | 17235.101 | 38.62 | 10.12 | 38.80 | 42.70 | 44.84 | 54.00 | -9.16 | AV |
| Horizontal | 4679.332 | 57.91 | 5.94 | 35.18 | 44.00 | 55.03 | 74.00 | -18.97 | Pk |
| Horizontal | 4679.332 | 44.54 | 5.94 | 35.18 | 44.00 | 41.66 | 54.00 | -12.34 | AV |
| Horizontal | 11490.164 | 56.68 | 8.46 | 38.71 | 44.50 | 59.35 | 74.00 | -14.65 | Pk |
| Horizontal | 11490.164 | 40.16 | 8.46 | 38.71 | 44.50 | 42.83 | 54.00 | -11.17 | AV |
| Horizontal | 17235.196 | 58.65 | 10.12 | 38.38 | 44.10 | 63.05 | 74.00 | -10.95 | Pk |
| Horizontal | 17235.196 | 42.23 | 10.12 | 38.38 | 44.10 | 46.63 | 54.00 | -7.37 | AV |
| middle Channel (5785 MHz)-Above 1G | | | | | | | | | |
| Vertical | 4592.228 | 59.82 | 6.48 | 36.35 | 44.05 | 58.6 | 74.00 | -15.4 | Pk |
| Vertical | 4592.228 | 43.32 | 6.48 | 36.35 | 44.05 | 42.1 | 54.00 | -11.9 | AV |
| Vertical | 11570.203 | 61.11 | 8.47 | 37.88 | 44.51 | 62.95 | 74.00 | -11.05 | Pk |
| Vertical | 11570.203 | 43.26 | 8.47 | 37.88 | 44.51 | 45.1 | 54.00 | -8.9 | AV |
| Vertical | 17355.147 | 59.53 | 10.12 | 38.8 | 44.10 | 64.35 | 74.00 | -9.65 | Pk |
| Vertical | 17355.147 | 42.27 | 10.12 | 38.8 | 42.70 | 48.49 | 54.00 | -5.51 | AV |
| Horizontal | 4592.526 | 58.63 | 6.48 | 36.37 | 44.05 | 57.43 | 74.00 | -16.57 | Pk |
| Horizontal | 4592.526 | 43.37 | 6.48 | 36.37 | 44.05 | 42.17 | 54.00 | -11.83 | AV |
| Horizontal | 11570.123 | 60.09 | 8.47 | 38.64 | 44.50 | 62.7 | 74.00 | -11.3 | Pk |
| Horizontal | 11570.123 | 42.28 | 8.47 | 38.64 | 44.50 | 44.89 | 54.00 | -9.11 | AV |
| Horizontal | 17355.269 | 57.59 | 10.12 | 38.38 | 44.10 | 61.99 | 74.00 | -12.01 | Pk |
| Horizontal | 17355.269 | 42.22 | 10.12 | 38.38 | 44.10 | 46.62 | 54.00 | -7.38 | AV |
| High Channel (5825 MHz)-Above 1G | | | | | | | | | |
| Vertical | 6039.199 | 57.61 | 7.10 | 37.24 | 43.50 | 58.45 | 74.00 | -15.55 | Pk |
| Vertical | 6039.199 | 42.22 | 7.10 | 37.24 | 43.50 | 43.06 | 54.00 | -10.94 | AV |
| Vertical | 11652.562 | 58.96 | 8.46 | 37.68 | 44.50 | 60.6 | 74.00 | -13.4 | Pk |
| Vertical | 11652.562 | 41.12 | 8.46 | 37.68 | 44.50 | 42.76 | 54.00 | -11.24 | AV |
| Vertical | 17473.128 | 58.51 | 10.12 | 38.8 | 44.10 | 63.33 | 74.00 | -10.67 | Pk |
| Vertical | 17473.128 | 40.32 | 10.12 | 38.8 | 42.70 | 46.54 | 54.00 | -7.46 | AV |
| Horizontal | 6039.232 | 59.92 | 7.10 | 37.24 | 43.50 | 60.76 | 74.00 | -13.24 | Pk |
| Horizontal | 6039.232 | 43.33 | 7.10 | 37.24 | 43.50 | 44.17 | 54.00 | -9.83 | AV |
| Horizontal | 11652.319 | 52.26 | 8.46 | 38.57 | 44.50 | 54.79 | 74.00 | -19.21 | Pk |
| Horizontal | 11652.319 | 40.14 | 8.46 | 38.57 | 44.50 | 42.67 | 54.00 | -11.33 | AV |
| Horizontal | 17474.062 | 57.76 | 10.12 | 38.38 | 44.10 | 62.16 | 74.00 | -11.84 | Pk |
| Horizontal | 17474.062 | 40.32 | 10.12 | 38.38 | 44.10 | 44.72 | 54.00 | -9.28 | AV |

Note:"802.11a(5G)" mode is the worst mode. PK value is lower than the Average value limit, So average didn't record.

The amplitude of spurious emissions that are attenuated by more than 20dB below the permissible value has no need to be reported.

Emission level (dBuV/m) = 20 log Emission level (uV/m).

Corrected Reading: Antenna Factor + Cable Loss + Read Level - Preamp Factor = Level.



4. POWER SPECTRAL DENSITY TEST

4.1 APPLIED PROCEDURES / LIMIT

According to FCC §15.407(a)(3)

For the band 5.15-5.25 GHz,

(i) For an outdoor access point operating in the band 5.15-5.25 GHz, the maximum power spectral density shall not exceed 17 dBm in any 1 megahertz band. If transmitting antennas of directional gain greater than 6 dBi are used, both the maximum conducted output power and the maximum power spectral density shall be reduced by the amount in dB that the directional gain of the antenna exceeds 6 dBi. The maximum e.i.r.p. at any elevation angle above 30 degrees as measured from the horizon must not exceed 125 mW (21 dBm).

(ii) For an indoor access point operating in the band 5.15-5.25 GHz, the maximum power spectral density shall not exceed 17 dBm in any 1 megahertz band. If transmitting antennas of directional gain greater than 6 dBi are used, both the maximum conducted output power and the maximum power spectral density shall be reduced by the amount in dB that the directional gain of the antenna exceeds 6 dBi.

(iii) For fixed point-to-point access points operating in the band 5.15-5.25 GHz, the maximum power spectral density shall not exceed 17 dBm in any 1 megahertz band. Fixed point-to-point U-NII devices may employ antennas with directional gain up to 23 dBi without any corresponding reduction in the maximum conducted output power or maximum power spectral density. For fixed point-to-point transmitters that employ a directional antenna gain greater than 23 dBi, a 1 dB reduction in maximum conducted output power and maximum power spectral density is required for each 1 dB of antenna gain in excess of 23 dBi. Fixed, point-to-point operations exclude the use of point-to-multipoint systems, omnidirectional applications, and multiple collocated transmitters transmitting the same information. The operator of the U-NII device, or if the equipment is professionally installed, the installer, is responsible for ensuring that systems employing high gain directional antennas are used exclusively for fixed, point-to-point operations.

(iv) For client devices in the 5.15-5.25 GHz band, the maximum power spectral density shall not exceed 11 dBm in any 1 megahertz band. If transmitting antennas of directional gain greater than 6 dBi are used, both the maximum conducted output power and the maximum power spectral density shall be reduced by the amount in dB that the directional gain of the antenna exceeds 6 dBi.

For the band 5.725-5.85 GHz

(3) For the band 5.725-5.85 GHz, the maximum power spectral density shall not exceed 30 dBm in any 500-kHz band. If transmitting antennas of directional gain greater than 6 dBi are used, both the maximum conducted output power and the maximum power spectral density shall be reduced by the amount in dB that the directional gain of the antenna exceeds 6 dBi.

4.2 TEST PROCEDURE

For devices operating in the bands 5.15-5.25 GHz, 5.25-5.35 GHz, and 5.47-5.725 GHz, the above procedures make use of 1 MHz RBW to satisfy directly the 1 MHz reference bandwidth specified in § 15.407(a)(5). For devices operating in the band 5.725-5.85 GHz, the rules specify a measurement bandwidth of 500 kHz. Many spectrum analyzers do not have 500 kHz RBW, thus a narrower RBW may need to be used. The rules permit the use of a RBWs less than 1 MHz, or 500 kHz, “provided that the measured power is integrated over the full reference bandwidth” to show the total power over the specified measurement bandwidth (i.e., 1 MHz, or 500 kHz). If measurements are performed using a reduced resolution bandwidth (< 1 MHz, or < 500 kHz) and integrated over 1 MHz, or 500 KHz bandwidth, the following adjustments to the procedures apply:

- a) Set $RBW \geq 1/T$, where T is defined in section II.B.I.a).
- b) Set $VBW \geq 3 RBW$.
- c) If measurement bandwidth of Maximum PSD is specified in 500 kHz, add $10\log(500\text{kHz}/RBW)$ to the measured result, whereas $RBW (< 500 \text{ KHz})$ is the reduced resolution bandwidth of the spectrum analyzer set during measurement.
- d) If measurement bandwidth of Maximum PSD is specified in 1 MHz, add $10\log(1\text{MHz}/RBW)$ to the measured result, whereas $RBW (< 1 \text{ MHz})$ is the reduced resolution bandwidth of spectrum analyzer set during measurement.
- e) Care must be taken to ensure that the measurements are performed during a period of continuous transmission or are corrected upward for duty cycle.

Note: As a practical matter, it is recommended to use reduced RBW of 100 KHz for the sections 5.c) and 5.d) above, since $RBW=100 \text{ KHz}$ is available on nearly all spectrum analyzers.

4.3 DEVIATION FROM STANDARD

No deviation.

4.4 TEST SETUP

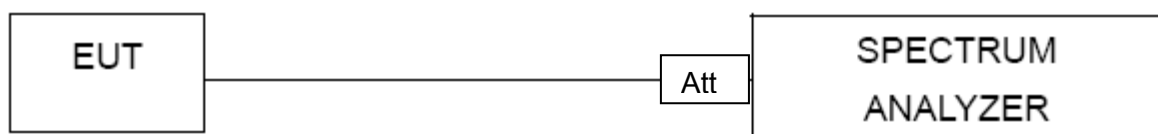

4.5 EUT OPERATION CONDITIONS

The EUT tested system was configured as the statements of 2.1 Unless otherwise a special operating condition is specified in the follows during the testing.



4.6 TEST RESULTS

| | | | |
|---------------|------------------------------------|---------------------|---------|
| Temperature : | 26 °C | Relative Humidity : | 54% |
| Pressure : | 101kPa | Test Voltage : | DC 3.7V |
| Test Mode : | TX Frequency Band I (5150-5250MHz) | | |

| Mode | Frequency | Measured Power Density (dBm) | Limit (dBm) | Result |
|-------------|-----------|------------------------------|-------------|--------|
| 802.11 a | 5180 MHz | -20.302 | 11 | PASS |
| | 5200 MHz | -19.752 | 11 | PASS |
| | 5240 MHz | -19.140 | 11 | PASS |
| 802.11 n20 | 5180 MHz | -21.138 | 11 | PASS |
| | 5200 MHz | -20.213 | 11 | PASS |
| | 5240 MHz | -18.981 | 11 | PASS |
| 802.11 n40 | 5190 MHz | -22.772 | 11 | PASS |
| | 5230 MHz | -21.319 | 11 | PASS |
| 802.11 AC20 | 5180 MHz | -19.488 | 11 | PASS |
| | 5200 MHz | -20.055 | 11 | PASS |
| | 5240 MHz | -19.586 | 11 | PASS |
| 802.11 AC40 | 5190 MHz | -23.282 | 11 | PASS |
| | 5230 MHz | -22.544 | 11 | PASS |
| 802.11 AC80 | 5210 MHz | -23.739 | 11 | PASS |



(802.11a) PSD plot on channel 36

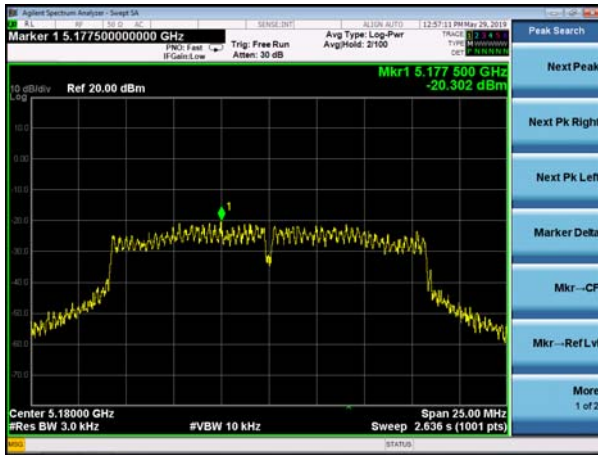

(802.11n20) PSD plot on channel 36

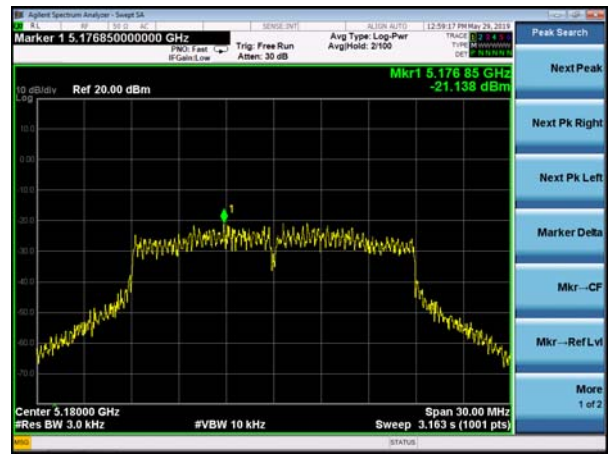

(802.11a) PSD plot on channel 40

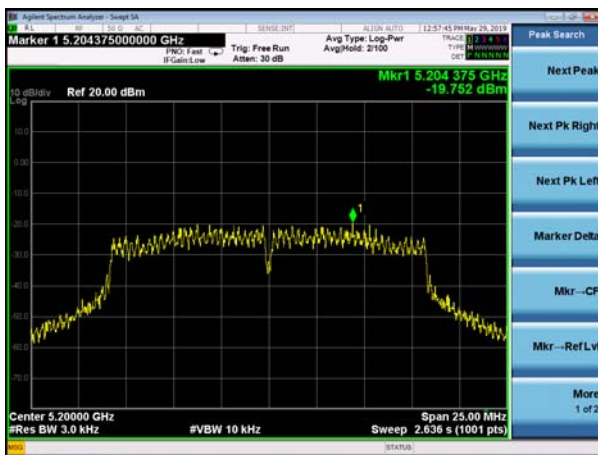

(802.11n20) PSD plot on channel 40

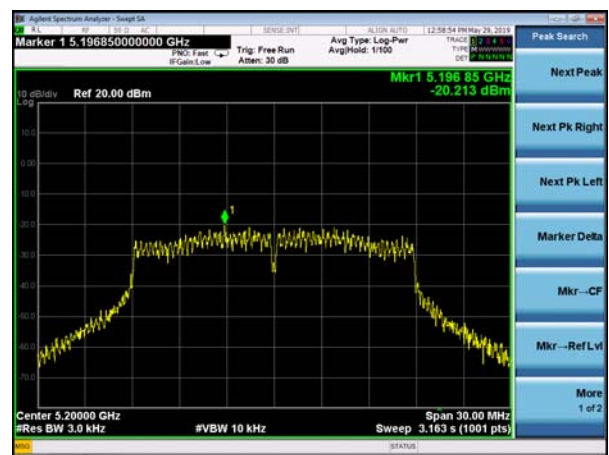

(802.11a) PSD plot on channel 48

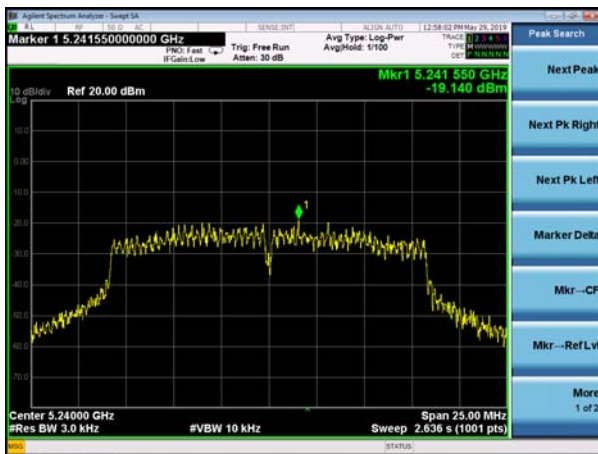

(802.11n20) PSD plot on channel 48

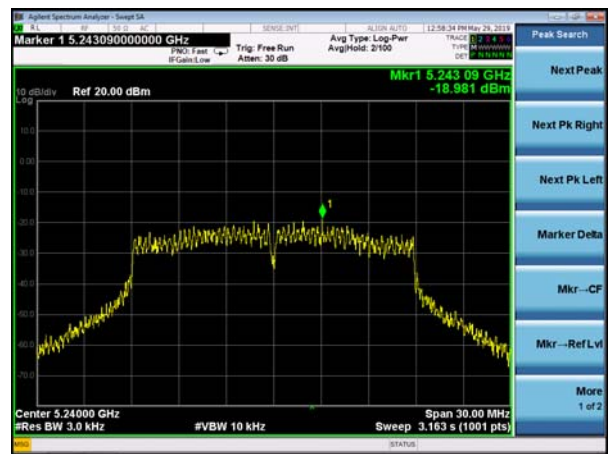



(802.11n40) PSD plot on channel 38

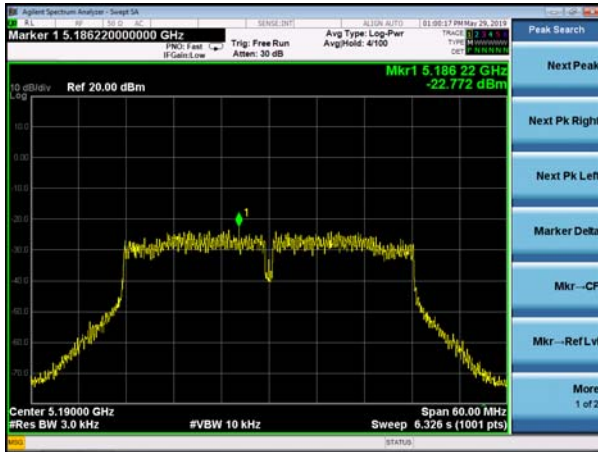

(802.11ac20) PSD plot on channel 36

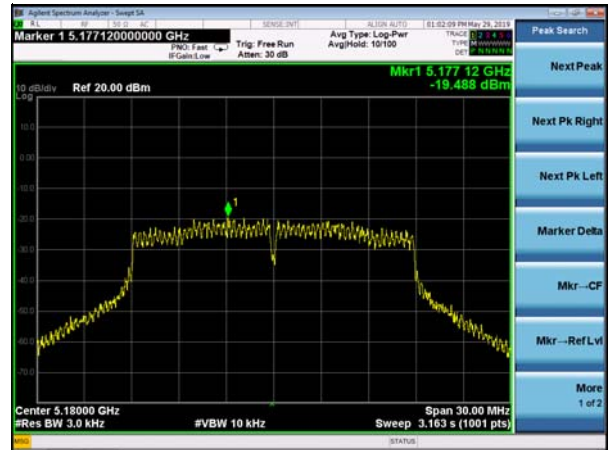

(802.11n40) PSD plot on channel 46

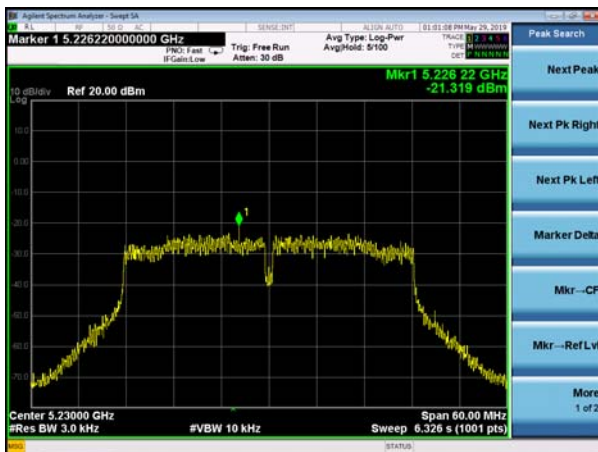

(802.11ac20) PSD plot on channel 40

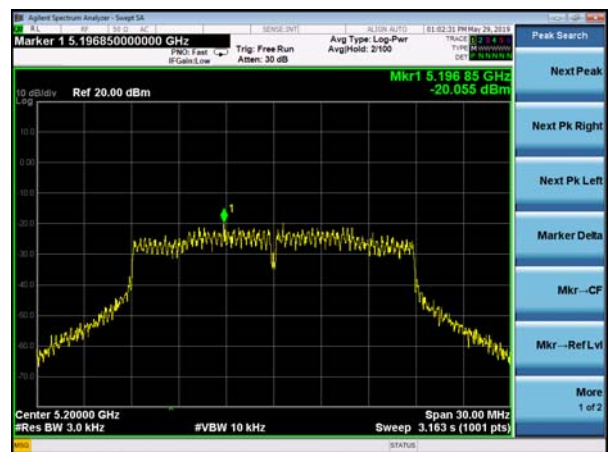

(802.11ac20) PSD plot on channel 48

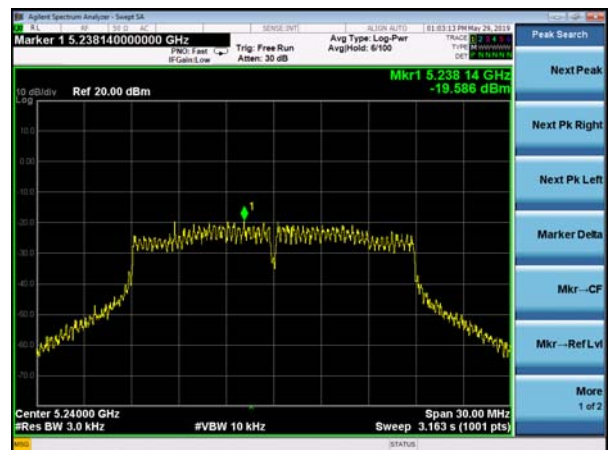



(802.11ac40) PSD plot on channel 38

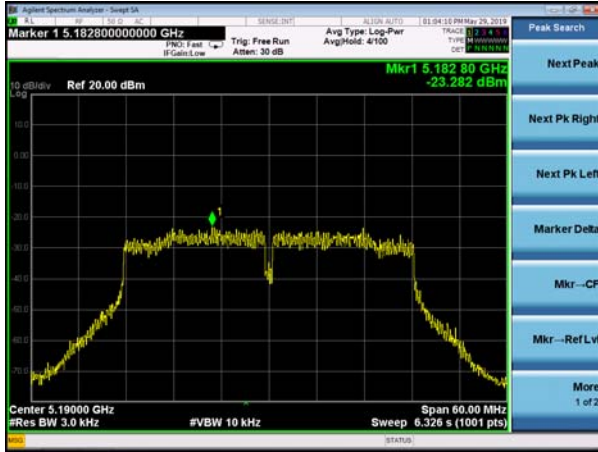

(802.11ac80) PSD plot on channel 42

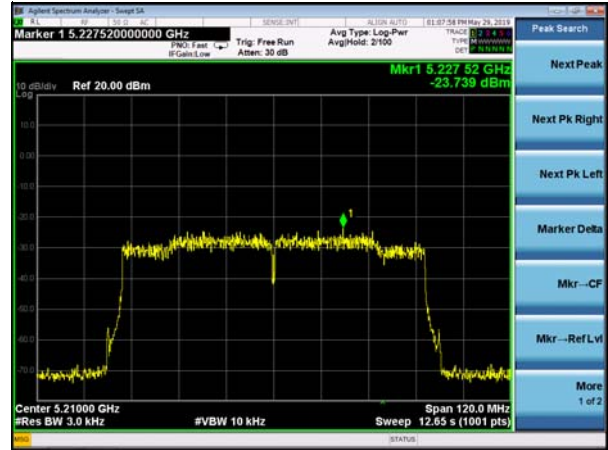

(802.11ac40) PSD plot on channel 46

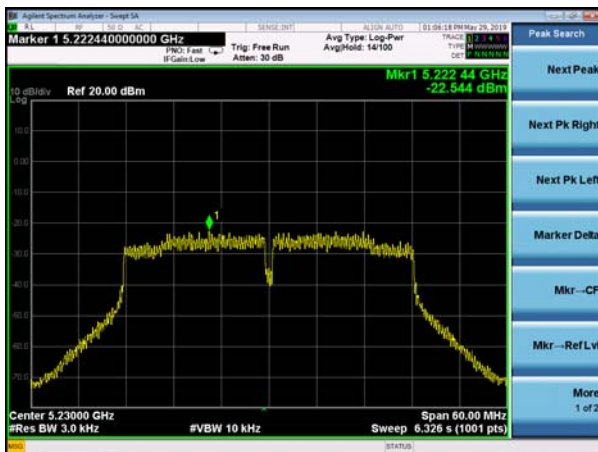



| | | | |
|---------------|-------------------------------------|---------------------|---------|
| Temperature : | 26 °C | Relative Humidity : | 54% |
| Pressure : | 101kPa | Test Voltage : | DC 3.7V |
| Test Mode : | TX Frequency Band IV (5745-5825MHz) | | |

| Mode | Frequency | Measured Power Density (dBm) | Limit (dBm) | Result |
|-------------|-----------|------------------------------|-------------|--------|
| 802.11 a | 5745 MHz | -21.739 | 30 | PASS |
| | 5785 MHz | -20.503 | 30 | PASS |
| | 5825 MHz | -20.308 | 30 | PASS |
| 802.11 n20 | 5745 MHz | -21.344 | 30 | PASS |
| | 5785 MHz | -20.075 | 30 | PASS |
| | 5825 MHz | -21.996 | 30 | PASS |
| 802.11 n40 | 5755 MHz | -21.949 | 30 | PASS |
| | 5795 MHz | -23.139 | 30 | PASS |
| 802.11 AC20 | 5745 MHz | -20.981 | 30 | PASS |
| | 5785 MHz | -20.847 | 30 | PASS |
| | 5825 MHz | -20.859 | 30 | PASS |
| 802.11 AC40 | 5755 MHz | -23.375 | 30 | PASS |
| | 5795 MHz | -22.912 | 30 | PASS |
| 802.11 AC80 | 5775 MHz | -24.639 | 30 | PASS |



(802.11a) PSD plot on channel 149

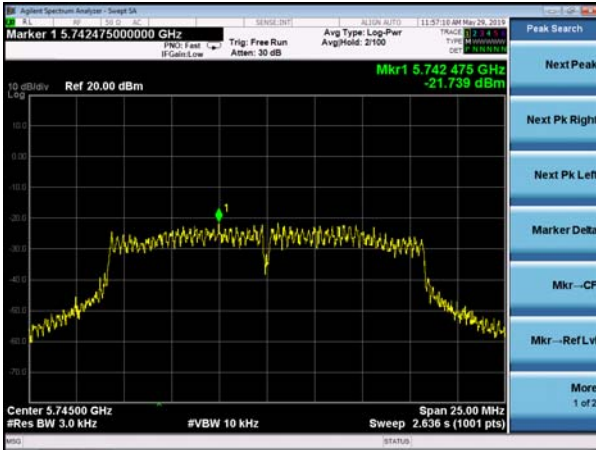

(802.11n20) PSD plot on channel 149

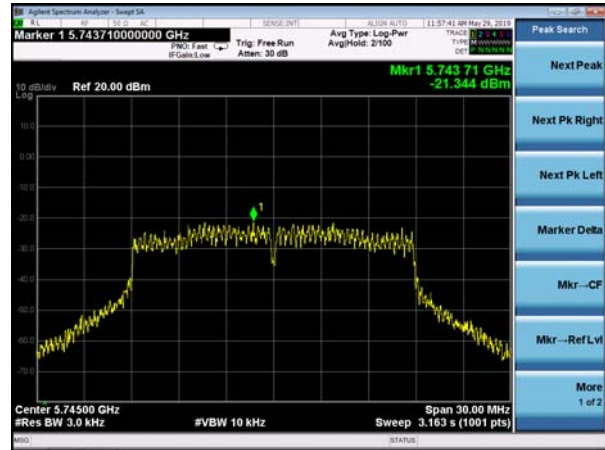

(802.11a) PSD plot on channel 157

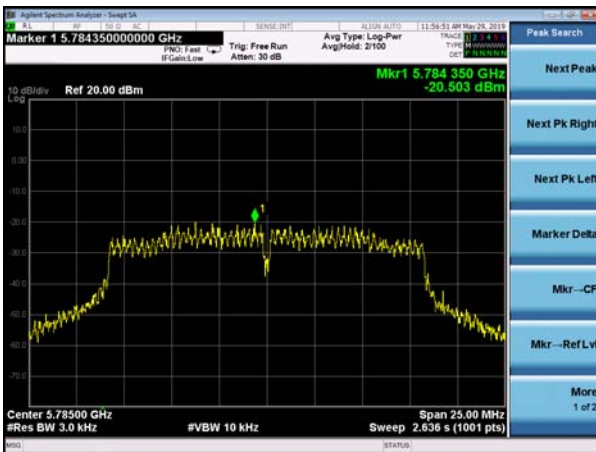

(802.11n20) PSD plot on channel 157

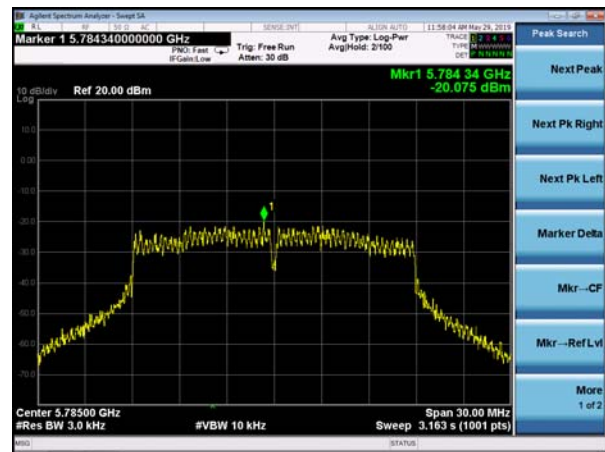

(802.11a) PSD plot on channel 165

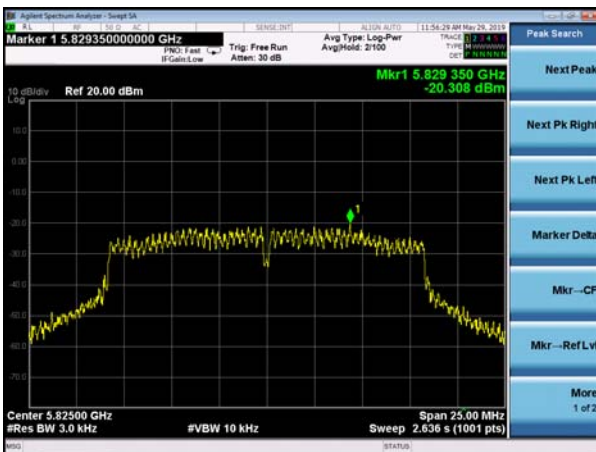

(802.11n20) PSD plot on channel 165

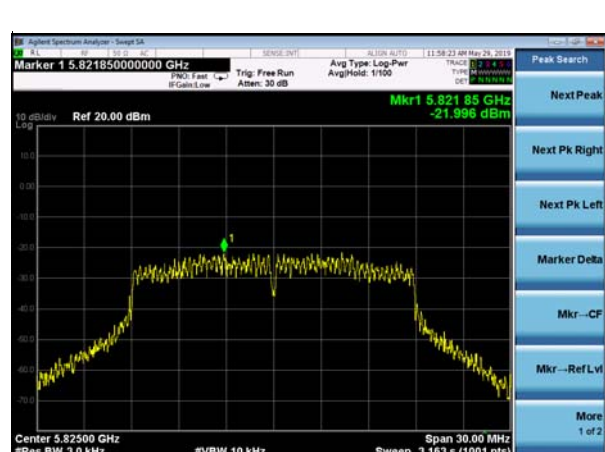



(802.11n40) PSD plot on channel 151

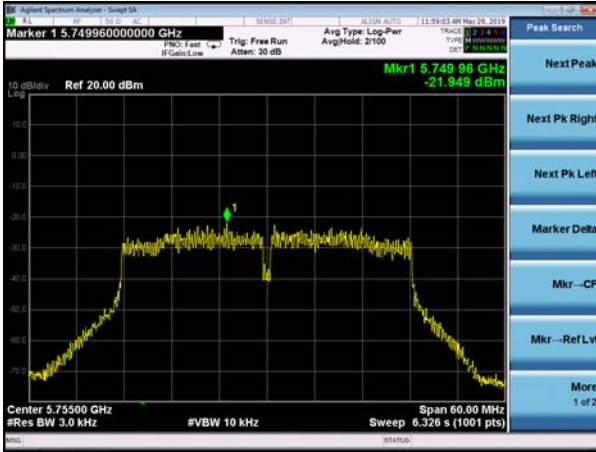

(802.11ac20) PSD plot on channel 149

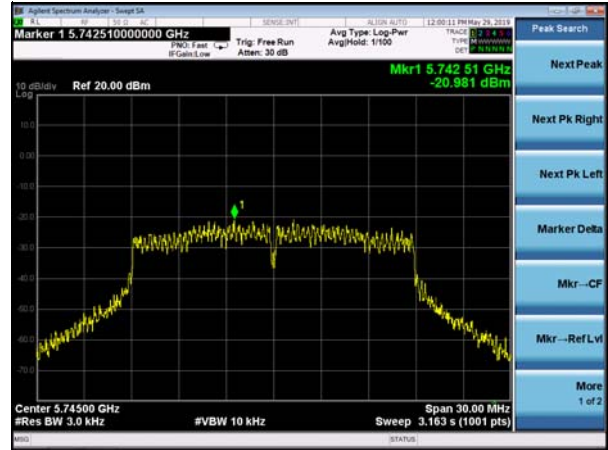

(802.11n40) PSD plot on channel 159

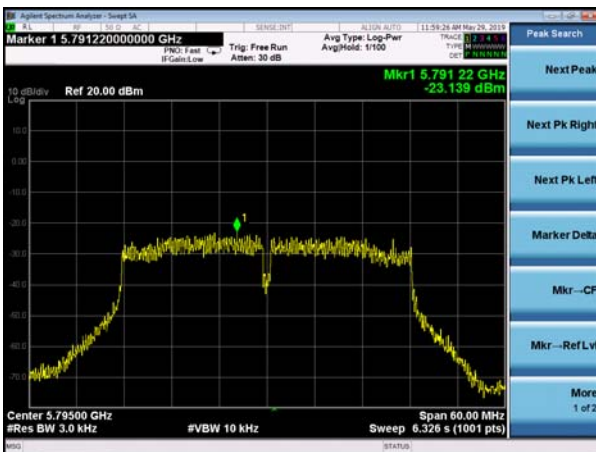

(802.11ac20) PSD plot on channel 157

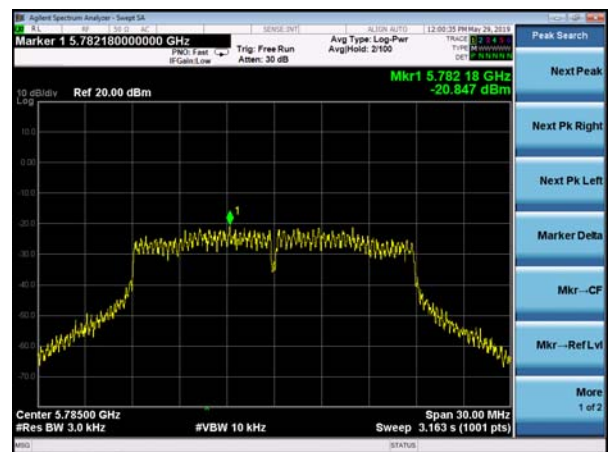

(802.11ac20) PSD plot on channel 165

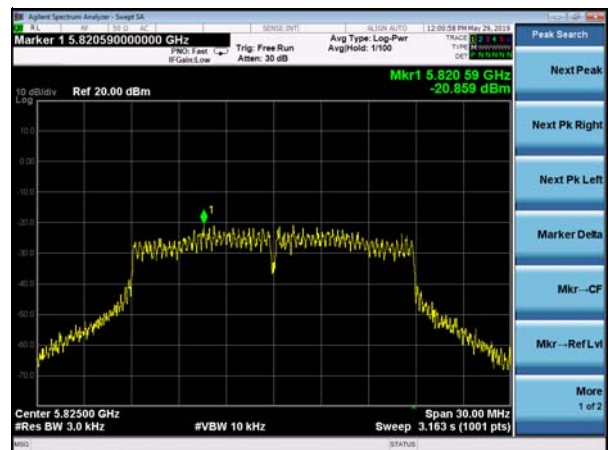



(802.11ac40) PSD plot on channel 151

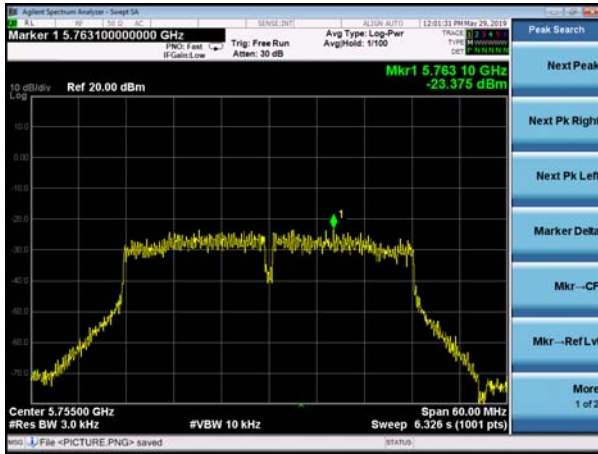

(802.11ac80) PSD plot on channel 155

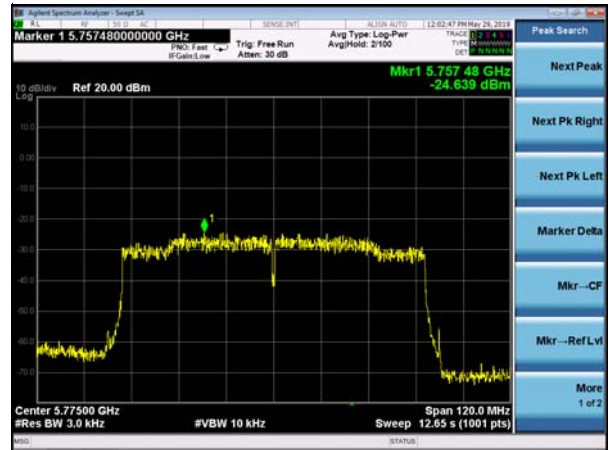

(802.11ac40) PSD plot on channel 159

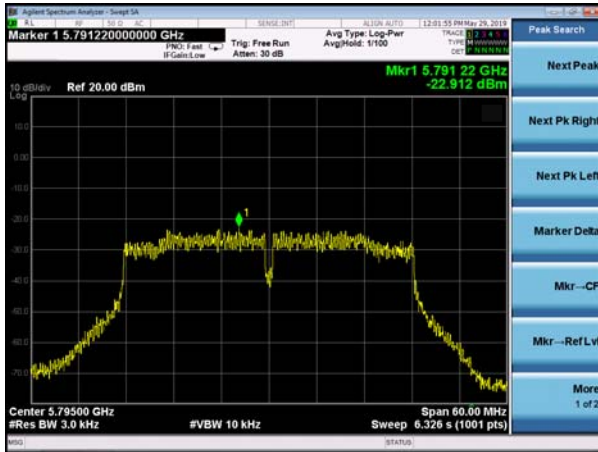



5. 26DB & 99% EMISSION BANDWIDTH

5.1 APPLIED PROCEDURES / LIMIT

The maximum power spectral density is measured as a conducted emission by direct connection of a calibrated test instrument to the equipment under test. If the device cannot be connected directly, alternative techniques acceptable to the Commission may be used. Measurements in the 5.725-5.85 GHz band are made over a reference bandwidth of 500 kHz or the 26 dB emission bandwidth of the device, whichever is less. Measurements in the 5.15-5.25 GHz, 5.25-5.35 GHz, and the 5.47-5.725 GHz bands are made over a bandwidth of 1 MHz or the 26 dB emission bandwidth of the device, whichever is less. A narrower resolution bandwidth can be used, provided that the measured power is integrated over the full reference bandwidth.

5.2 TEST PROCEDURE



- a) Set RBW = approximately 1% of the emission bandwidth.
- b) Set the VBW > RBW.
- c) Detector = Peak.
- d) Trace mode = max hold.
- e) Measure the maximum width of the emission that is 26 dB down from the maximum of the emission. Compare this with the RBW setting of the analyzer. Readjust RBW and repeat measurement as needed until the RBW/EBW ratio is approximately 1%.

The following procedure shall be used for measuring (99 %) power bandwidth:

1. Set center frequency to the nominal EUT channel center frequency.
2. Set span = 1.5 times to 5.0 times the OBW.
3. Set RBW = 1 % to 5 % of the OBW
4. Set $VBW \geq 3 \cdot RBW$
5. Video averaging is not permitted. Where practical, a sample detection and single sweep mode shall be used. Otherwise, peak detection and max hold mode (until the trace stabilizes) shall be used.
6. Use the 99 % power bandwidth function of the instrument (if available).
7. If the instrument does not have a 99 % power bandwidth function, the trace data points are recovered and directly summed in power units. The recovered amplitude data points, beginning at the lowest frequency, are placed in a running sum until 0.5 % of the total is reached; that frequency is recorded as the lower frequency. The process is repeated until 99.5 % of the total is reached; that frequency is recorded as the upper frequency. The 99% occupied bandwidth is the difference between these two frequencies.

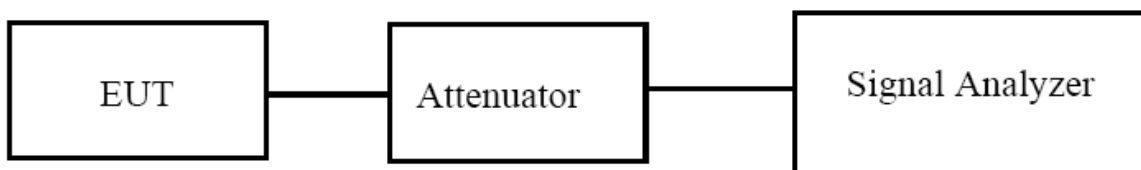

5.3 EUT OPERATION CONDITIONS

The EUT tested system was configured as the statements of 2.4 Unless otherwise a special operating condition is specified in the follows during the testing.



5.4 TEST RESULTS

| | | | |
|---------------|------------------------------------|---------------------|---------|
| Temperature : | 26 °C | Relative Humidity : | 54% |
| Pressure : | 101kPa | Test Voltage : | DC 3.7V |
| Test Mode : | TX Frequency Band I (5150-5250MHz) | | |

| Mode | Channel | Frequency (MHz) | 99% bandwidth(MHz) | 26dB bandwidth (MHz) | Result |
|-------------|---------|-----------------|--------------------|----------------------|--------|
| | | | Antenna A | Antenna A | |
| 802.11a | CH36 | 5180 | 16.365 | 20.33 | Pass |
| | CH40 | 5200 | 16.374 | 20.69 | Pass |
| | CH48 | 5240 | 16.388 | 20.88 | Pass |
| 802.11 n20 | CH36 | 5180 | 17.582 | 19.78 | Pass |
| | CH40 | 5200 | 17.578 | 21.20 | Pass |
| | CH48 | 5240 | 17.587 | 20.87 | Pass |
| 802.11 n40 | CH 38 | 5190 | 35.904 | 39.33 | Pass |
| | CH 46 | 5230 | 35.961 | 39.92 | Pass |
| 802.11 AC20 | CH36 | 5180 | 17.575 | 20.78 | Pass |
| | CH40 | 5200 | 17.576 | 20.00 | Pass |
| | CH48 | 5240 | 17.592 | 19.99 | Pass |
| 802.11 AC40 | CH 38 | 5190 | 35.889 | 39.04 | Pass |
| | CH 46 | 5230 | 36.031 | 39.77 | Pass |
| 802.11 AC80 | CH 42 | 5210 | 75.285 | 77.87 | Pass |



Test plot

(802.11a) -26dB&99%Bandwidth plot on channel 36

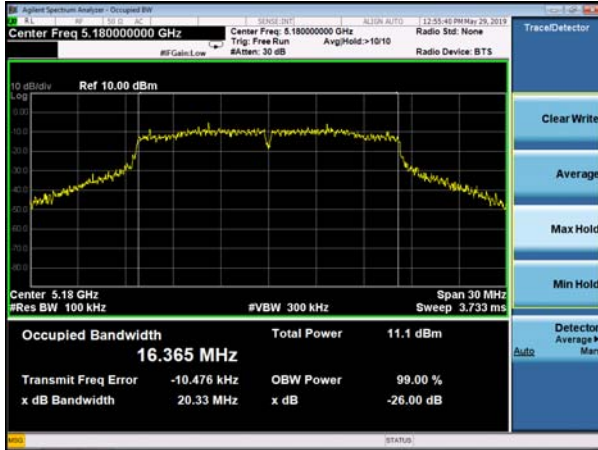

(802.11 n20) -26dB&99%Bandwidth plot on channel 36

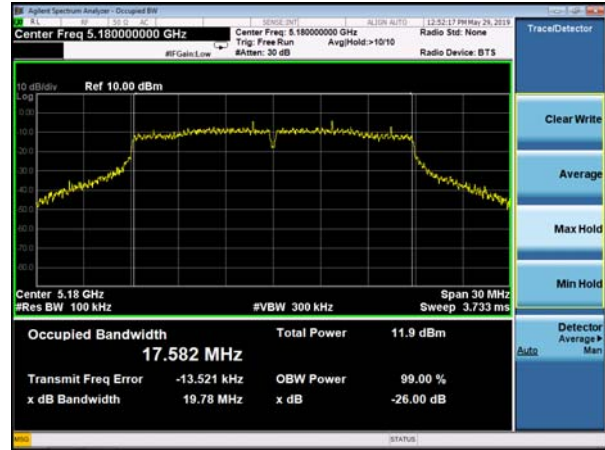

(802.11a) -26dB&99%Bandwidth plot on channel 40

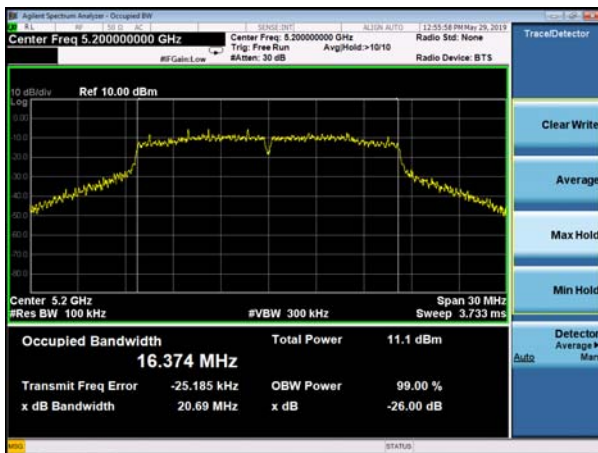

(802.11 n20) -26dB&99%Bandwidth plot on channel 40



(802.11a) -26dB&99%Bandwidth plot on channel 48



(802.11 n20) -26dB&99%Bandwidth plot on channel 48

