



# FCC TEST REPORT

According to

## FCC Rules and Regulations Part 15 Subpart C

Applicant : EGROUP COMPUTER SYSTEMS CO., LTD.

---

Address : No.239, Sec. 2, Tiding Blvd., Neihu Dist, Taipei City 14, Taiwan (R.O.C)

---

Applicant : EGROUP COMPUTER SYSTEMS CO., LTD.

---

Address : No.239, Sec. 2, Tiding Blvd., Neihu Dist, Taipei City 14, Taiwan (R.O.C)

---

Equipment : Tablet PC

---

Model No : TE70SA3

---

FCC ID : 2AEKR-TE70SA3

---

- The test result refers exclusively to the test presented test model / sample.
- Without written approval of **CerpPASS Technology Corp.** the test report shall not be reproduced except in full.
- The test report must not be used by the clients to claim product certification approval by **NVLAP** or any agency of the Government.

I HEREBY CERTIFY THAT :

The measurements shown in this test report were made in accordance with the procedures given in **ANSI C63.10– 2013** and the energy emitted by this equipment was **passed**.  
**CISPR PUB. 22 and FCC Part 15** in both radiated and conducted emission class B limits. Testing was carried out on Jul 30 ,2015 at **CerpPASS Technology Corp.**

Prepared By: Leo Chen  
 Leo Chen

Laboratory accreditation

Approved By: Miro Chueh  
 Miro Chueh





### Release History

Attachment No.	Date	Description
SEFI1507030	2015-07-30	Initial release



## Table of Contents

<b>1. Report of Measurements and Examinations .....</b>	<b>5</b>
1.1 List of Measurements and Examinations .....	5
<b>2. Test Configuration of Equipment under Test .....</b>	<b>6</b>
2.1 Feature of Equipment under Test .....	6
2.2 Carrier Frequency of Channels .....	8
2.3 Power Setting Levels.....	8
2.4 Duty cycle .....	9
2.5 Test Manner.....	10
2.6 Description of Test System .....	10
2.7 General Information of Test .....	10
2.8 Measurement Uncertainty .....	11
<b>3. Antenna Requirements .....</b>	<b>12</b>
3.1 Standard Applicable.....	12
3.2 Antenna Construction and Directional Gain .....	12
<b>4. Test of Conducted Emission .....</b>	<b>13</b>
4.1 Test Limit .....	13
4.2 Test Procedures.....	13
4.3 Typical Test Setup .....	14
4.4 Measurement Equipment .....	14
4.5 Test Result and Data .....	15
<b>5. Test of Radiated Emission .....</b>	<b>17</b>
5.1 Test Limit .....	17
5.2 Test Procedures.....	17
5.3 Typical Test Setup .....	18
5.4 Measurement Equipment .....	20
5.5 Test Result and Data .....	21
<b>6. Occupied Bandwidth.....</b>	<b>27</b>
6.1 Test Limit .....	27
6.2 Test Procedures.....	27
6.3 Test Setup Layout.....	27
6.4 Measurement Equipment .....	27
6.5 Test Result and Data .....	28
<b>7. Maximum Output Power .....</b>	<b>31</b>
7.1 Test Limit .....	31
7.2 Test Procedure .....	31
7.3 Test Setup Layout.....	31
7.4 Measurement Equipment .....	31
7.5 Test Result and Data .....	32
<b>8. Band Edges Measurement .....</b>	<b>34</b>
8.1 Test Limit .....	34
8.2 Test Procedure .....	34



---

8.3 Test Setup Layout.....	34
8.4 Measurement Equipment .....	35
Test Result and Data .....	36
<b>9. Power Spectral Density .....</b>	<b>50</b>
9.1 Test Limit .....	50
9.2 Test Procedure .....	50
9.3 Test Setup Layout.....	50
9.4 Measurement Equipment .....	50
9.5 Test Result and Data .....	51
<b>10. Restricted Bands of Operation .....</b>	<b>54</b>
10.1 Labeling Requirement .....	54



## 1. Report of Measurements and Examinations

### 1.1 List of Measurements and Examinations

Performed Test Item	Normative References	Test Performed	Deviation	Result
Conducted Emission	FCC CFR Title 47 Part 15 Subpart C: 2014 Section 15.207	Yes	N/A	Pass
Radiated Emission	FCC CFR Title 47 Part 15 Subpart C: 2014 Section 15.209 RSS-Gen Issue 4 November 2014 Section 6.13 and Section 7.1.2	Yes	No	Pass
RF Antenna Conducted Spurious	FCC CFR Title 47 Part 15 Subpart C: 2014 Section 15.247(d) RSS-247 Issue 1 May 2015 Section 5.5	Yes	No	Pass
Radiated Emission Band Edge	FCC CFR Title 47 Part 15 Subpart C: 2014 15.247(d) RSS-247 Issue 1 May 2015 Section 5.5	Yes	No	Pass
Operation Frequency Range of 20dB Bandwidth	FCC CFR Title 47 Part 15 Subpart C: 2014 15.215(c)	Yes	No	Pass
Occupied Bandwidth	FCC CFR Title 47 Part 15 Subpart C: 2014 Section 15.247(a)(2) RSS-247 Issue 1 May 2015 Section 5.2(1)	Yes	No	Pass
Output Power	FCC CFR Title 47 Part 15 Subpart C: 2014 Section 15.247(b)(3) RSS-247 Issue 1 May 2015 Section 5.4(4)	Yes	No	Pass
Power Spectral Density	FCC CFR Title 47 Part 15 Subpart C: 2014 Section 15.247(e) RSS-247 Issue 1 May 2015 Section 5.2(2)	Yes	No	Pass



## 2. Test Configuration of Equipment under Test

### 2.1 Feature of Equipment under Test

<b>Product Name:</b>	Tablet PC	
<b>Model Name:</b>	TE70SA3	
<b>GPS</b>	Class of SRD	Class 3
	Antenna Gain	PCB 1.27dBi
<b>2G:</b>	Support Band	GSM850/PCS1900
	GPRS Class	Class 12
	Uplink	GSM 850: 824~849MHz PCS 1900: 1850~1910MHz
	Downlink	GSM 850: 869~894MHz PCS 1900: 1930~1990MHz
	Type of modulation	GMSK for GPRS; 8PSK for EDGE
	Antenna Type	Dipole
	Antenna Gain	GSM 850: 1.17dBi PCS1900: 1.89dBi
<b>3G</b>	Support Band	WCDMA Band 2/WCDMA Band 5
	Uplink	WCDMA Band 2: 1850~1910MHz WCDMA Band 5: 824~849MHz
	Downlink	WCDMA Band 2: 1930~1990MHz WCDMA Band 5: 869~894MHz
	Type of modulation	QPSK for Uplink
	Antenna Type	Dipole
	Antenna Gain	Band 2: 1.98dBi Band 5: 1.34dBi
<b>Bluetooth:</b>	Bluetooth Specification	3.0HS + Version 4.0
	Modulation Type	V3.0+HS: GFSK, Pi/4 DQPSK, 8DPSK V4.0: GFSK
	Frequency Range	2402 - 2480 MHz
	Channel Number	V3.0+HS: 79



		V4.0: 40
	Data Rate	V3.0+HS: 1Mbps(GFSK), 2Mbps(Pi/4 DQPSK), 3Mbps (8DPSK) V4.0: 1Mbps(GFSK)
	Channel Separation	V3.0+HS: 1MHz V4.0: 2MHz
	Antenna Type/ gain	PCB Antenna 1.27 dBi
<b>Wi-Fi</b>	Spreading	802.11b: DSSS 802.11g / n: OFDM
	Frequency Range	802.11b/g/n(20MHz): 2412-2462MHz
	Number of Channels	802.11b/g/n (20MHz):11
	Data Rate	802.11b: 11, 5.5, 2, 1 Mbps 802.11g: 54, 48, 36, 24, 18, 12, 9, 6 Mbps 802.11n: up to 300Mbps
	Antenna Type	PCB Antenna
	Peak Antenna Gain	1.27dBi
<b>Adapter</b>	Model No.:	WB-10E05FU
	Input	100-240V~50-60Hz 0.4A max.
	Output:	DC 5V, 2A



## 2.2 Carrier Frequency of Channels

### For 2.4G 802.11b, 802.11g, 802.11n (20MHz)

Channel	Frequency(MHz)	Channel	Frequency(MHz)
01	2412	07	2442
02	2417	08	2447
03	2422	09	2452
04	2427	10	2457
05	2432	11	2462
06	2437	---	---

## 2.3 Power Setting Levels

Mode	Frequency (MHz)	Power setting
802.11b	2412	62
	2437	63
	2462	63
802.11g	2412	64
	2437	64
	2462	64
802.11n20	2412	64
	2437	64
	2462	64

Note: MTool software is used for power transmission control offered by the manufactory.





### 2.4 Duty cycle

Test Item	Duty cycle
Test Date	2015-07-22

Mode	Frequency (MHz)	Measurement (%)
802.11b	2437	99
802.11g	2437	88
802.11n(20MHz)	2437	88

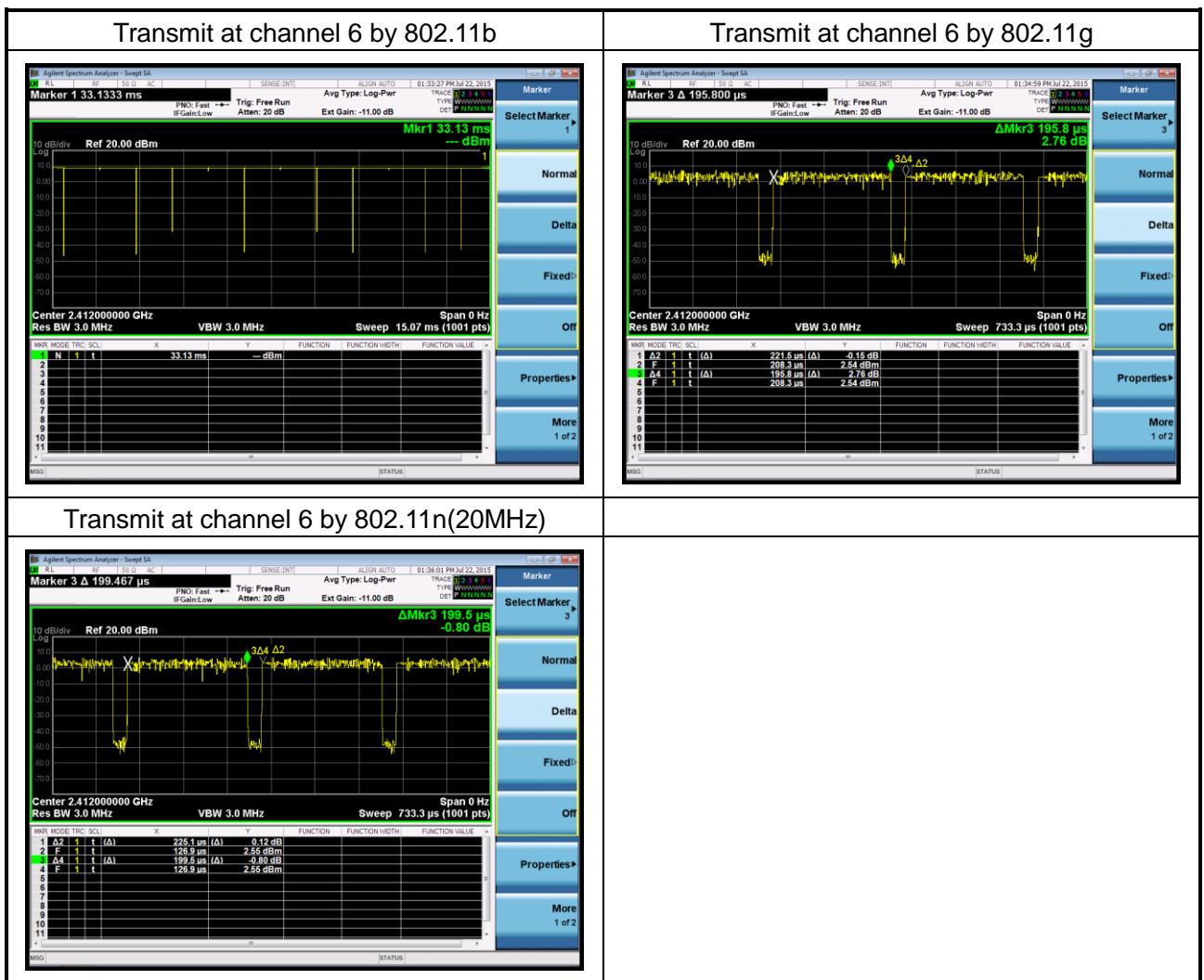



## 2.5 Test Manner

Test Manner	
1	During testing, the interface cables and equipment positions were varied according to FCC Rules and Regulations Part 15 Subpart C
2	Connect the HUB, Notebook, IP Express and EUT.
3	Adjust the EUT at the test mode and the test channel. Then test.
Test mode	
1	Transmit by 802.11b
2	Transmit by 802.11g
3	Transmit by 802.11n (20MHz)

## 2.6 Description of Test System

No	Device	Manufacturer	Model No.	Description
1	N/A	N/A	N/A	N/A

## 2.7 General Information of Test

Test Site:	CerpPASS Technology Corp.
Performand Location :	No.66,Tangzhuang Road, Suzhou Industrial Park, Jiangsu 215006, China
NVLAP LAB Code :	200814-0
FCC Registration Number :	916572, 331395
IC Registration Number :	7290A-1, 7290A-2



## 2.8 Measurement Uncertainty

Measurement Item	Measurement Frequency	Polarization	Uncertainty
Conducted Emission	9 kHz ~ 30 MHz	LINE/NEUTRAL	±2.71 dB
Radiated Emission	30 MHz ~ 25GHz	Vertical	±4.11 dB
		Horizontal	±4.10 dB
Occupied Bandwidth	---	---	±7500 Hz
Maximum Peak Output Power	---	---	±1.4 dB
Band Edges	---	---	±2.2 dB
Power Spectral Density	---	---	±2.2 dB



### 3. Antenna Requirements

#### 3.1 Standard Applicable

For intentional device, according to FCC 47 CFR Section 15.203, an intentional radiator shall be designed to ensure that no antenna other than that furnished by the responsible party shall be used with the device.

And according to FCC 47 CFR Section 15.247 (b), if transmitting antennas of directional gain greater than 6dBi are used, the power shall be reduced by the amount in dB that the directional gain of the antenna exceeds 6dBi.

#### 3.2 Antenna Construction and Directional Gain

Antenna	Antenna 1 PCB (1.27 dBi)
---------	--------------------------



## 4. Test of Conducted Emission

### 4.1 Test Limit

Conducted Emissions were measured from 150 kHz to 30 MHz with a bandwidth of 9 KHz on the 120 VAC power and return leads of the EUT according to the methods defined in ANSI C63.10-2013 Section 6.2. The EUT was placed on a nonmetallic stand in a shielded room 0.8 meters above the ground plane as shown in section 6.2.2. The interface cables and equipment positioning were varied within limits of reasonable applications to determine the position produced maximum conducted emissions.

Frequency (MHz)	Quasi Peak (dB $\mu$ V)	AVG (dB $\mu$ V)
0.15 – 0.5	66-56*	56-46*
0.5 – 5.0	56	46
5.0 – 30.0	60	50

\*Decreases with the logarithm of the frequency.

### 4.2 Test Procedures

The EUT was setup according to ANSI C63.10, 2013 and tested according to DTS test procedure of Oct 2014 KDB558074 for compliance to FCC 47CFR 15.247 requirements. The EUT was placed on a platform of nominal size, 1 m by 1.5 m, raised 80 cm above the conducting ground plane. The vertical conducting plane was located 40 cm to the rear of the EUT. All other surfaces of EUT were at least 80 cm from any other grounded conducting surface. The EUT and simulators are connected to the main power through a line impedance stabilization network (LISN). The LISN provides a 50 ohm /50uH coupling impedance for the measuring equipment. The peripheral devices are also connected to the main power through a LISN. (Please refer to the block diagram of the test setup and photographs) Each current-carrying conductor of the EUT power cord, except the ground (safety) conductor, was individually connected through a LISN to the input power source. The excess length of the power cord between the EUT and the LISN receptacle were folded back and forth at the center of the lead to form a bundle not exceeding 40 cm in length. Conducted emissions were investigated over the frequency range from 0.15MHz to 30MHz using a receiver bandwidth of 9kHz.



### 4.3 Typical Test Setup

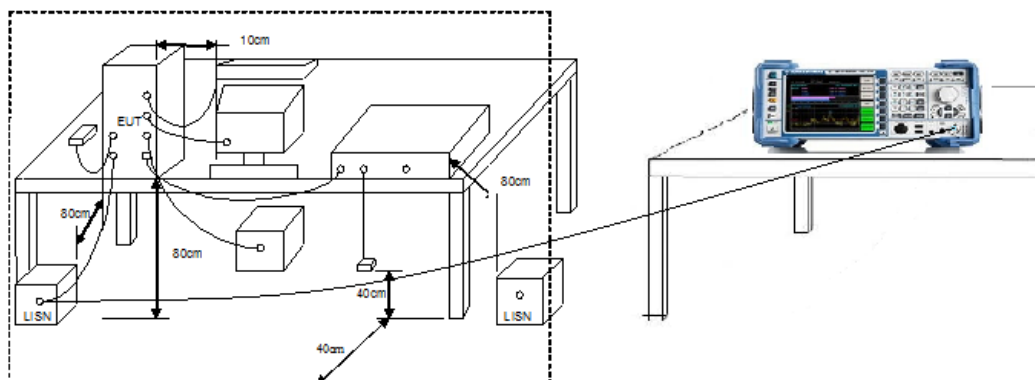

### 4.4 Measurement Equipment

Instrument	Manufacturer	Model No.	Serial No.	Calibration Date	Valid Date.
Test Receiver	R&S	ESCI	100565	2015.03.24	2016.03.23
AMN	R&S	ESH2-Z5	100182	2014.09.04	2015.09.03
Two-Line V-Network	R&S	ENV216	100325	2014.12.04	2015.12.03
ISN	FCC	FCC-TLISN-T2-02	20379	2015.03.24	2016.03.23
ISN	FCC	FCC-TLISN-T4-02	20380	2015.03.24	2016.03.23
ISN	FCC	FCC-TLISN-T8-02	20381	2015.03.24	2016.03.23
ISN	TESEQ	ISN ST08	30175	2015.03.24	2016.03.23
Current Probe	R&S	EZ-17	100303	2015.04.04	2016.04.03
Passive Voltage Probe	R&S	ESH2-Z3	100026	2015.03.29	2016.03.28
Pulse Limiter	R&S	ESH3-Z2	100529	2015.03.29	2016.03.28
Temperature/Humidity Meter	Zhicheng	ZC1-11	CEP-TH-004	2015.03.31	2016.03.30



### 4.5 Test Result and Data

Test Mode :	Mode 1: Normal Operation with wifi on		
AC Power :	AC 120V/60Hz	Phase :	LINE
Temperature :	22°C	Humidity :	50%
Pressure(mbar) :	1002	Date:	2015/07/22

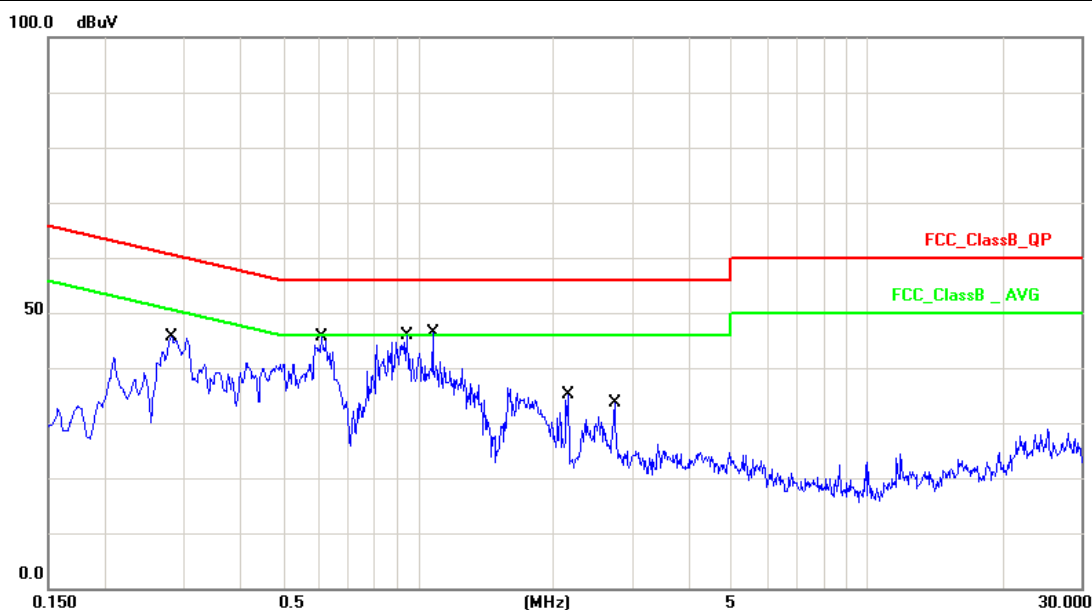

No.	Frequency (MHz)	Factor (dB)	Reading (dBuV)	Level (dBuV)	Limit (dBuV)	Margin (dB)	Detector
1	0.2819	10.14	39.37	49.51	60.76	-11.25	QP
2	0.2819	10.14	33.04	43.18	50.76	-7.58	AVG
3	0.6100	10.15	44.30	54.45	56.00	-1.55	QP
4	0.6100	10.15	26.43	36.58	46.00	-9.42	AVG
5	0.9460	10.16	32.08	42.24	56.00	-13.76	QP
6	0.9460	10.16	23.51	33.67	46.00	-12.33	AVG
7	1.0820	10.16	29.66	39.82	56.00	-16.18	QP
8	1.0820	10.16	20.30	30.46	46.00	-15.54	AVG
9	2.1660	10.17	17.26	27.43	56.00	-28.57	QP
10	2.1660	10.17	8.20	18.37	46.00	-27.63	AVG
11	2.7500	10.18	15.63	25.81	56.00	-30.19	QP
12	2.7500	10.18	9.85	20.03	46.00	-25.97	AVG

Note: Measurement Level = Reading Level + Correct Factor



Test Mode :	Mode 1: Normal Operation with wifi on		
AC Power :	AC 120V/60Hz	Phase :	NEUTRAL
Temperature :	22°C	Humidity :	50%
Pressure(mbar) :	1002	Date:	2015/07/22

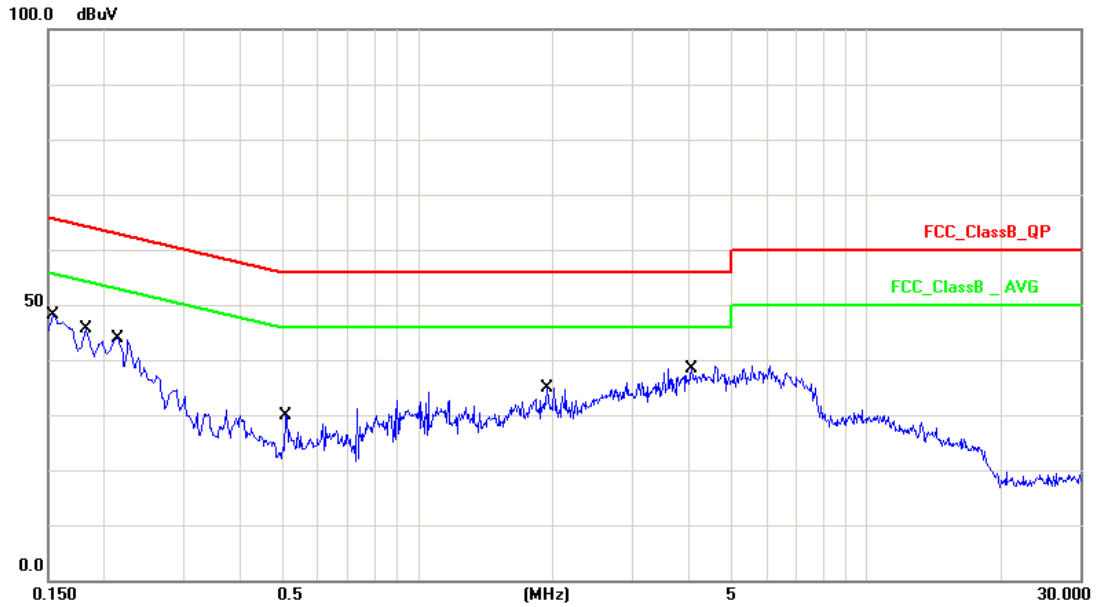

No.	Frequency (MHz)	Factor (dB)	Reading (dBuV)	Level (dBuV)	Limit (dBuV)	Margin (dB)	Detector
1	0.2900	10.14	39.23	49.37	60.52	-11.15	QP
2	0.2900	10.14	32.08	42.22	50.52	-8.30	AVG
3	0.5060	10.15	36.55	46.70	56.00	-9.30	QP
4	0.5060	10.15	26.46	36.61	46.00	-9.39	AVG
5	0.6100	10.16	43.09	53.25	56.00	-2.75	QP
6	0.6100	10.16	28.65	38.81	46.00	-7.19	AVG
7	0.8420	10.16	31.82	41.98	56.00	-14.02	QP
8	0.8420	10.16	21.31	31.47	46.00	-14.53	AVG
9	1.5580	10.18	17.82	28.00	56.00	-28.00	QP
10	1.5580	10.18	11.90	22.08	46.00	-23.92	AVG
11	2.2980	10.19	18.56	28.75	56.00	-27.25	QP
12	2.2980	10.19	11.23	21.42	46.00	-24.58	AVG

Note: Measurement Level = Reading Level + Correct Factor





## 5. Test of Radiated Emission

### 5.1 Test Limit

In any 100kHz bandwidth outside the frequency band in which the spread spectrum or digitally modulated intentional radiator is operating, the radio frequency power that is produced by the intentional radiator shall be at least 20dB below that in the 100kHz bandwidth within the band that contains the highest level of the desired power, based on either an RF conducted or a radiated measurement. If the transmitter measurement is based on the maximum conducted output power, the attenuation required under this paragraph shall be 30dB instead of 20dB. In addition, radiated emissions which fall in section 15.205(a) the restricted bands must also comply with the radiated emission limit specified in section 15.209(a).

FREQUENCIES(MHz)	FIELD STRENGTH (microvolts/meter)	MEASUREMENT DISTANCE(meters)
0.009~0.490	2400/F(kHz)	300
0.490~1.705	24000/F(kHz)	30
1.705~30.0	30	30
30~88	100	3
88~216	150	3
216~960	200	3
Above 960	500	3

### 5.2 Test Procedures

- The EUT was placed on a rotatable table top 0.8 meter for frequency below 1GHz and 1.5meter for frequency above 1GHz above ground.
- The EUT was set 3 meters from the interference receiving antenna which was mounted on the top of a variable height antenna tower.
- The table was rotated 360 degrees to determine the position of the highest radiation.
- The antenna is a broadband antenna and its height is varied between one meter and four meters above ground to find the maximum value of the field strength both horizontal polarization and vertical polarization of the antenna are set to make the measurement.
- For each suspected emission the EUT was arranged to its worst case and then tune the antenna tower (from 1 M to 4 M) and turn table (from 0 degree to 360 degrees) to find the maximum reading.
- Set the test-receiver system to Peak or CISPR quasi-peak Detect Function and specified bandwidth with Maximum Hold Mode.
- If the emission level of the EUT in peak mode was 3 dB lower than the limit specified, then testing will be stopped and peak values of EUT will be reported, otherwise, the emissions which do not have 3 dB margin will be repeated one by one using the quasi-peak method and reported.
- For testing above 1GHz, the emission level of the EUT in peak mode was 20dB lower than AVG limit (that means the emission level in peak mode also complies with the limit in AVG mode), then testing will be stopped and peak values of EUT will be reported, otherwise, the emissions will be measured in AVG mode again and reported.



### 5.3 Typical Test Setup

9kHz~30MHz Test Setup

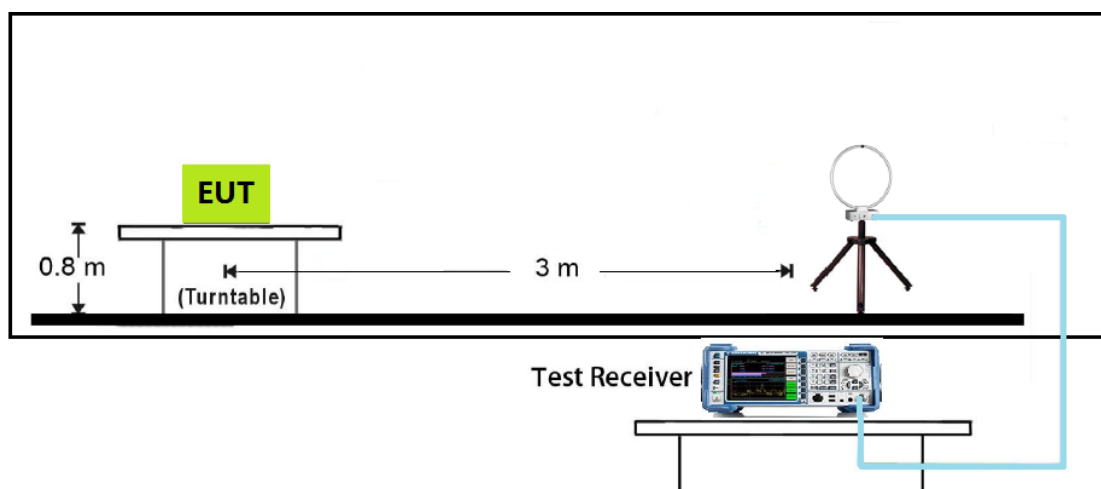

Below 1GHz Test Setup

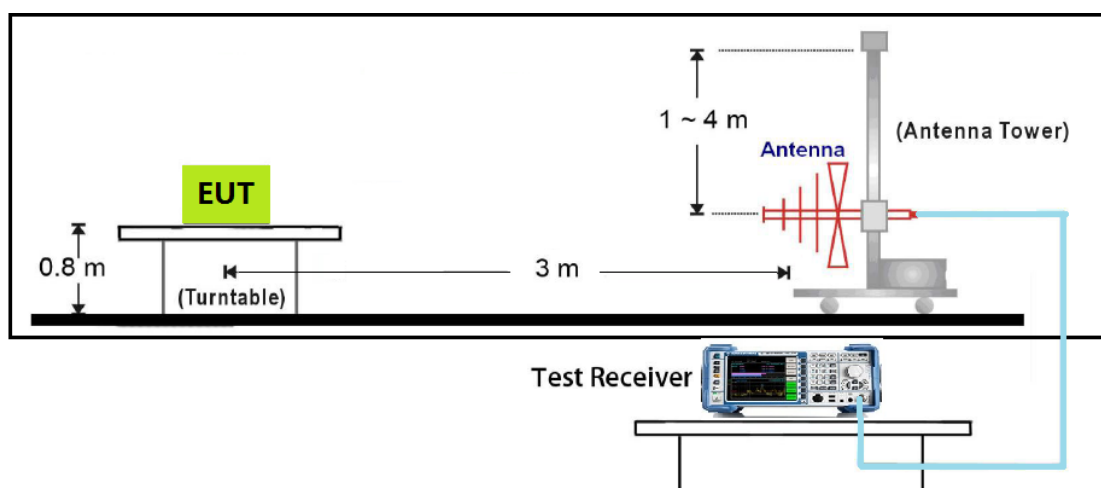



1GHz~18GHz Test Setup

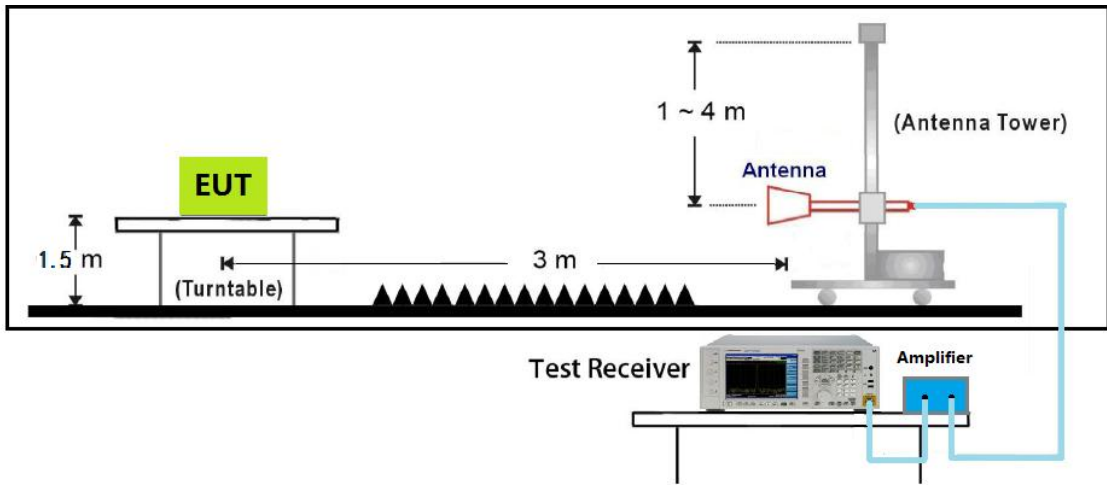

18GHz~40GHz Test Setup

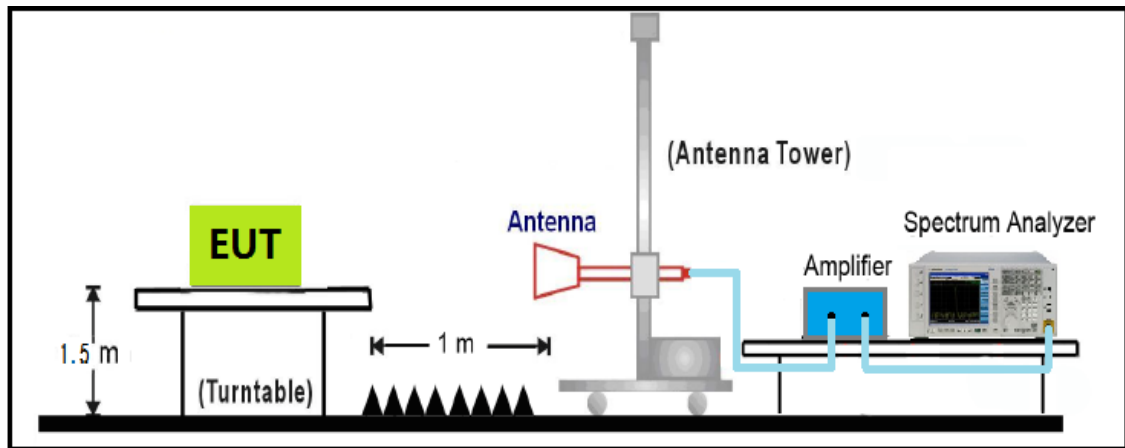

**5.4 Measurement Equipment**

Instrument/Ancillary	Manufacturer	Model No.	Serial No.	Calibration Date	Valid Date.
EMI Test Receiver	R&S	ESCI	100563	2015.02.10	2016.02.09
H64 Preamplifier	HP	8447F	3113A05582	2015.03.24	2016.03.23
Preamplifier	Agilent	8449B	3008A02342	2015.03.24	2016.03.23
Ultra Broadband Antenna	R&S	HL562	100362	2015.05.24	2016.05.23
Broad-Band Horn Antenna	Schwarzbeck	BBHA9120D	9120D-619	2015.05.24	2016.05.23
Broad-Band Horn Antenna	Schwarzbeck	BBHA9170	9170-348	2015.05.24	2016.05.23
Spectrum Analyzer	R&S	FSP40	100324	2015.03.23	2016.03.24
Temperature/ Humidity Meter	Zhicheng	ZC1-11	CEP-TH-002	2015.03.31	2016.03.30



## 5.5 Test Result and Data

The 9kHz-30MHz spurious emission is under limit 20dB more.

### 5.5.1 Test Result and Data of Transmitter

Under 1G:

Engineer :Wind	
Site : EMC Lab AC 102	Time : 2015-07-25
Limit : FCC_CLASS_B_03M_QP	Margin : 6
EUT : TE70SA3	Probe : VERTICAL/ HORIZONTAL
Power : AC 120V/60Hz	Note : Normal Link

No.	Frequency (MHz)	Factor (dB/m)	Reading (dBuV)	Level (dBuV/m)	Limit (dBuV/m)	Margin (dB)	Det.	AntPol. H/V
1	55.2200	-11.86	35.16	23.30	40.00	-16.70	QP	H
2	250.1899	-11.02	40.21	29.19	46.00	-16.81	QP	H
3	375.3199	-6.97	36.94	29.97	46.00	-16.03	QP	H
4	500.4499	-4.85	30.57	25.72	46.00	-20.28	QP	H
5	625.5800	-1.50	30.25	28.75	46.00	-17.25	QP	H
6	875.8400	2.05	27.99	30.04	46.00	-15.96	QP	H

No.	Frequency (MHz)	Factor (dB/m)	Reading (dBuV)	Level (dBuV/m)	Limit (dBuV/m)	Margin (dB)	Det.	AntPol. H/V
1	53.2800	-11.53	35.12	23.59	40.00	-16.41	QP	V
2	156.0999	-7.55	36.87	29.32	43.50	-14.18	QP	V
3	250.1899	-11.02	40.95	29.93	46.00	-16.07	QP	V
4	500.4499	-4.85	38.19	33.34	46.00	-12.66	QP	V
5	625.5800	-1.50	36.84	35.34	46.00	-10.66	QP	V
6	875.8400	2.05	34.97	37.02	46.00	-8.98	QP	V

Note:

1. All Readings below 1GHz are Quasi-Peak, above are performed with peak and/or AVG measurements as necessary.
2. Measurement Level = Reading Level + Correct Factor



Above 1G:

Engineer : Wind	
Site : EMC Lab AC 102	Time : 2015-07-25
Limit : FCC_15_03M_PK	Margin : 6
EUT : TE70SA3	Probe : VERTICAL/ HORIZONTAL
Power : AC 120V/60Hz	Note : Transmit by 802.11b (2412MHz)

No.	Frequency (MHz)	Factor (dB/m)	Reading (dBuV)	Level (dBuV/m)	Limit (dBuV/m)	Margin (dB)	Det.	AntPol. H/V
1	4824.000	4.24	44.52	48.76	74.00	-25.24	peak	H
2	7236.000	8.74	40.85	49.59	74.00	-24.41	peak	H
3	4824.000	4.24	44.82	49.06	74.00	-24.94	peak	V
4	7236.000	8.74	39.68	48.42	74.00	-25.58	peak	V

Engineer : Wind	
Site : EMC Lab AC 102	Time : 2015-07-25
Limit : FCC_15_03M_PK	Margin : 6
EUT : TE70SA3	Probe : VERTICAL/ HORIZONTAL
Power : AC 120V/60Hz	Note : Transmit by 802.11b (2437MHz)

No.	Frequency (MHz)	Factor (dB/m)	Reading (dBuV)	Level (dBuV/m)	Limit (dBuV/m)	Margin (dB)	Det.	AntPol. H/V
1	4874.000	4.09	44.46	48.55	74.00	-25.45	peak	H
2	7311.000	8.96	40.57	49.53	74.00	-24.47	peak	H
3	4874.000	4.09	43.84	47.93	74.00	-26.07	peak	V
4	7311.000	8.96	40.24	49.20	74.00	-24.80	peak	V

Note:

1. All Readings below 1GHz are Quasi-Peak, above are performed with peak and/or AVG measurements as necessary.
2. Measurement Level = Reading Level + Correct Factor



Engineer : Wind	
Site : EMC Lab AC 102	Time : 2015-07-25
Limit : FCC_15_03M_PK	Margin : 6
EUT : TE70SA3	Probe : VERTICAL/ HORIZONTAL
Power : AC 120V/60Hz	Note : Transmit by 802.11b (2462MHz)

No.	Frequency (MHz)	Factor (dB/m)	Reading (dBuV)	Level (dBuV/m)	Limit (dBuV/m)	Margin (dB)	Det.	AntPol. H/V
1	4924.000	4.18	43.04	47.22	74.00	-26.78	peak	H
2	7386.000	9.07	40.01	49.08	74.00	-24.92	peak	H
3	4924.000	4.18	43.39	47.57	74.00	-26.43	peak	V
4	7386.000	9.07	40.25	49.32	74.00	-24.68	peak	V

Engineer : Wind	
Site : EMC Lab AC 102	Time : 2015-07-25
Limit : FCC_15_03M_PK	Margin : 6
EUT : TE70SA3	Probe : VERTICAL/ HORIZONTAL
Power : AC 120V/60Hz	Note : Transmit by 802.11g (2412MHz)

No.	Frequency (MHz)	Factor (dB/m)	Reading (dBuV)	Level (dBuV/m)	Limit (dBuV/m)	Margin (dB)	Det.	AntPol. H/V
1	4824.000	4.24	44.02	48.26	74.00	-25.74	peak	H
2	7236.000	8.74	40.35	49.09	74.00	-24.91	peak	H
3	4824.000	4.24	44.32	48.56	74.00	-25.44	peak	V
4	7236.000	8.74	38.68	47.42	74.00	-26.58	peak	V

Note:

1. All Readings below 1GHz are Quasi-Peak, above are performed with peak and/or AVG measurements as necessary.
2. Measurement Level = Reading Level + Correct Factor



Engineer : Wind	
Site : EMC Lab AC 102	Time : 2015-07-25
Limit : FCC_15_03M_PK	Margin : 6
EUT : TE70SA3	Probe : VERTICAL/ HORIZONTAL
Power : AC 120V/60Hz	Note : Transmit by 802.11g (2437MHz)

No.	Frequency (MHz)	Factor (dB/m)	Reading (dBuV)	Level (dBuV/m)	Limit (dBuV/m)	Margin (dB)	Det.	AntPol. H/V
1	4874.000	4.09	44.96	49.05	74.00	-24.95	peak	H
2	7311.000	8.96	39.57	48.53	74.00	-25.47	peak	H
3	4874.000	4.09	43.34	47.43	74.00	-26.57	peak	V
4	7311.000	8.96	39.74	48.70	74.00	-25.30	peak	V

Engineer : Wind	
Site : EMC Lab AC 102	Time : 2015-07-25
Limit : FCC_15_03M_PK	Margin : 6
EUT : TE70SA3	Probe : VERTICAL/ HORIZONTAL
Power : AC 120V/60Hz	Note : Transmit by 802.11g (Ant 0) (2462MHz)

No.	Frequency (MHz)	Factor (dB/m)	Reading (dBuV)	Level (dBuV/m)	Limit (dBuV/m)	Margin (dB)	Det.	AntPol. H/V
1	4924.000	4.18	43.04	47.22	74.00	-26.78	peak	H
2	7386.000	9.07	39.01	48.08	74.00	-25.92	peak	H
3	4924.000	4.18	42.89	47.07	74.00	-26.93	peak	V
4	7386.000	9.07	39.75	48.82	74.00	-25.18	peak	V

Note:

- All Readings below 1GHz are Quasi-Peak, above are performed with peak and/or AVG measurements as necessary.
- Measurement Level = Reading Level + Correct Factor





Engineer : Wind	
Site : EMC Lab AC 102	Time : 2015-07-25
Limit : FCC_15_03M_PK	Margin : 6
EUT : TE70SA3	Probe : VERTICAL/ HORIZONTAL
Power : AC 120V/60Hz	Note : Transmit by 802.11n(20MHz) (2412MHz)

No.	Frequency (MHz)	Factor (dB/m)	Reading (dBuV)	Level (dBuV/m)	Limit (dBuV/m)	Margin (dB)	Det.	AntPol. H/V
1	4824.000	4.24	44.02	48.26	74.00	-25.74	peak	H
2	7236.000	8.74	40.85	49.59	74.00	-24.41	peak	H
3	4824.000	4.24	45.32	49.56	74.00	-24.44	peak	V
4	7236.000	8.74	39.68	48.42	74.00	-25.58	peak	V

Engineer : Wind	
Site : EMC Lab AC 102	Time : 2015-07-25
Limit : FCC_15_03M_PK	Margin : 6
EUT : TE70SA3	Probe : VERTICAL/ HORIZONTAL
Power : AC 120V/60Hz	Note : Transmit by 802.11n(20MHz) (2437MHz)

No.	Frequency (MHz)	Factor (dB/m)	Reading (dBuV)	Level (dBuV/m)	Limit (dBuV/m)	Margin (dB)	Det.	AntPol. H/V
1	4874.000	4.09	44.96	49.05	74.00	-24.95	peak	H
2	7311.000	8.96	39.57	48.53	74.00	-25.47	peak	H
3	4874.000	4.09	43.84	47.93	74.00	-26.07	peak	V
4	7311.000	8.96	40.74	49.70	74.00	-24.30	peak	V

Note:

1. All Readings below 1GHz are Quasi-Peak, above are performed with peak and/or AVG measurements as necessary.
2. Measurement Level = Reading Level + Correct Factor



Engineer : Wind	
Site : EMC Lab AC 102	Time : 2015-07-25
Limit : FCC_15_03M_PK	Margin : 6
EUT : TE70SA3	Probe : VERTICAL/ HORIZONTAL
Power : AC 120V/60Hz	Note : Transmit by 802.11n(20MHz) (2462MHz)

No.	Frequency (MHz)	Factor (dB/m)	Reading (dBuV)	Level (dBuV/m)	Limit (dBuV/m)	Margin (dB)	Det.	AntPol. H/V
1	4924.000	4.18	43.54	47.72	74.00	-26.28	peak	H
2	7386.000	9.07	38.51	47.58	74.00	-26.42	peak	H
3	4924.000	4.18	43.39	47.57	74.00	-26.43	peak	V
4	7386.000	9.07	40.75	49.82	74.00	-24.18	peak	V

Note:

1. All Readings below 1GHz are Quasi-Peak, above are performed with peak and/or AVG measurements as necessary.
2. Measurement Level = Reading Level + Correct Factor



## 6. Occupied Bandwidth

### 6.1 Test Limit

Systems using digital modulation techniques may operate in the 902 - 928 MHz, 2400 - 2483.5 MHz, and 5725- 5850 MHz band. The minimum 6 dB bandwidth shall be at least 500 kHz.

### 6.2 Test Procedures

- a. The transmitter output was connected to the spectrum analyzer.
- b. Set RBW of spectrum analyzer to 100KHz and  $VBW \geq 3x RBW$ .
- c. The 6 dB bandwidth is defined as the total spectrum the power of which is higher than peak power minus 6 dB.
- d. The 6dB Bandwidth was measured and recorded.

### 6.3 Test Setup Layout

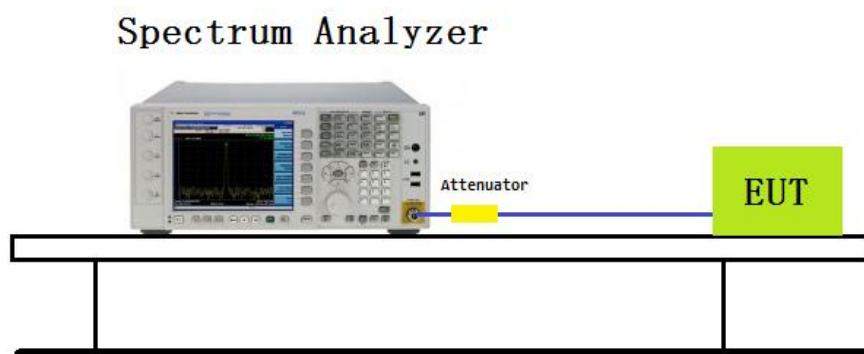

### 6.4 Measurement Equipment

Instrument/Ancillary	Model No.	Manufacturer	Serial No.	Calibration Date	Valid Date
Spectrum Analyzer	N9010A	Agilent	MY54200207	2014/10/9	2015/10/8



6.5 Test Result and Data

Test Item	Occupied Bandwidth
Test Mode	Transmit by 802.11b
Test Date	2015-07-22

Channel No.	Frequency (MHz)	Measurement Level (MHz)	99% Occupied Bandwidth (kHz)	Result
01	2412	9.93	14058	Pass
06	2437	10.06	13898	Pass
11	2462	10.10	14782	Pass

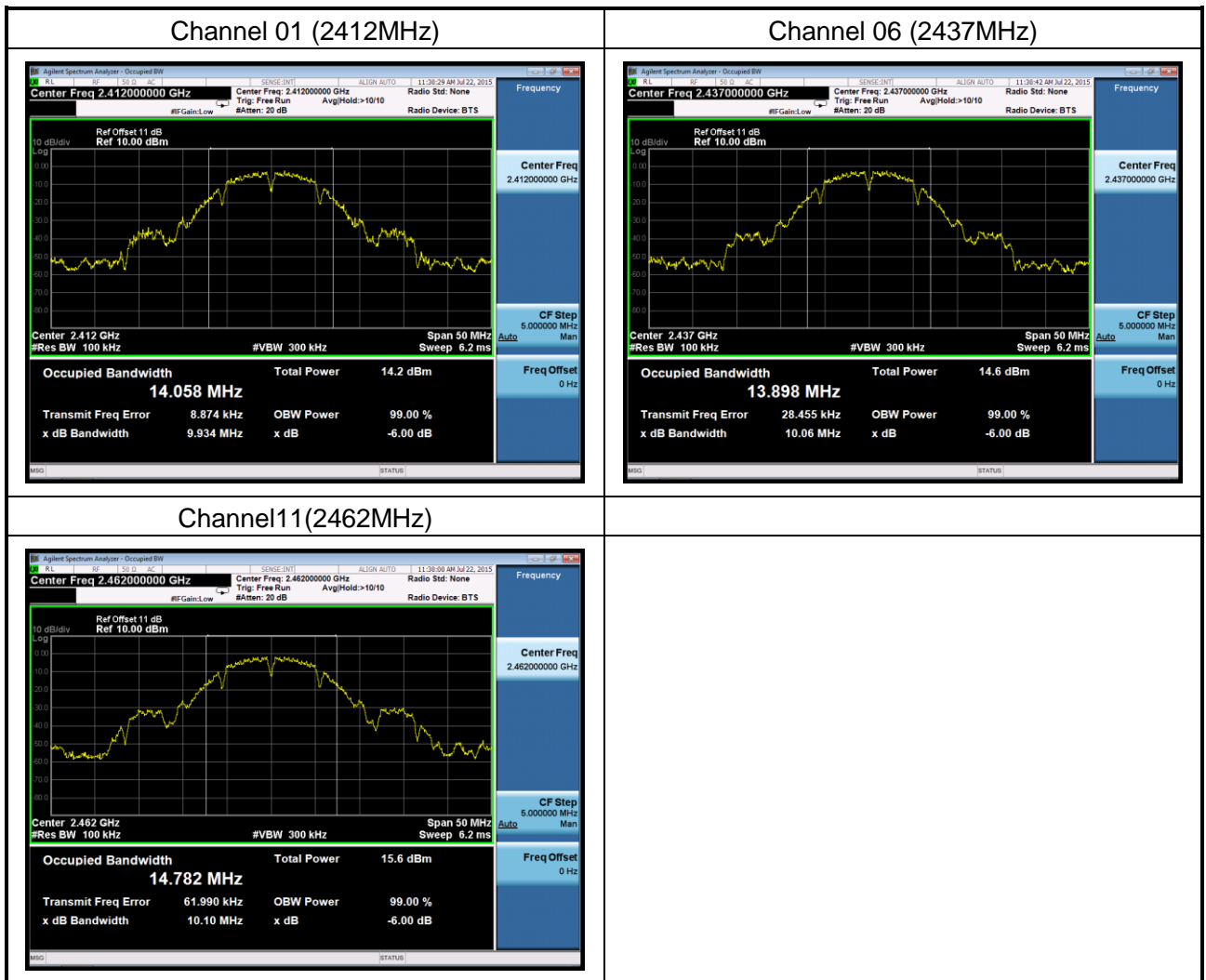



Test Item	Occupied Bandwidth
Test Mode	Transmit by 802.11g
Test Date	2015-07-22

Channel No.	Frequency (MHz)	Measurement Level (MHz)	99% Occupied Bandwidth (kHz)	Result
01	2412	16.38	20698	Pass
06	2437	16.37	20564	Pass
11	2462	16.37	20591	Pass

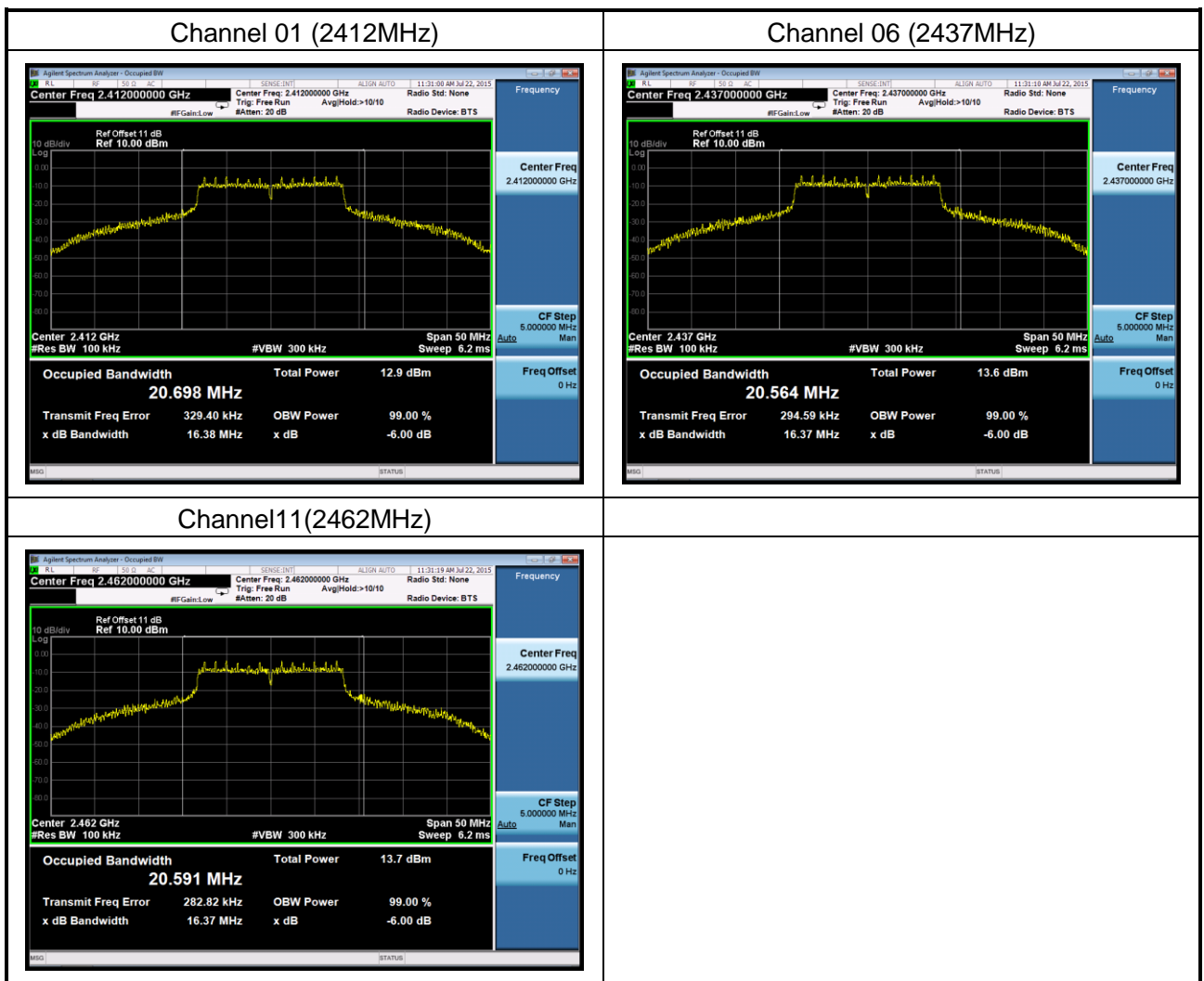



Test Item	Occupied Bandwidth
Test Mode	Transmit by 802.11n (20MHz)
Test Date	2015-07-22

Channel No.	Frequency (MHz)	Measurement Level (MHz)	99% Occupied Bandwidth (kHz)	Result
01	2412	17.62	21211	Pass
06	2437	17.61	21641	Pass
11	2462	17.62	21868	Pass

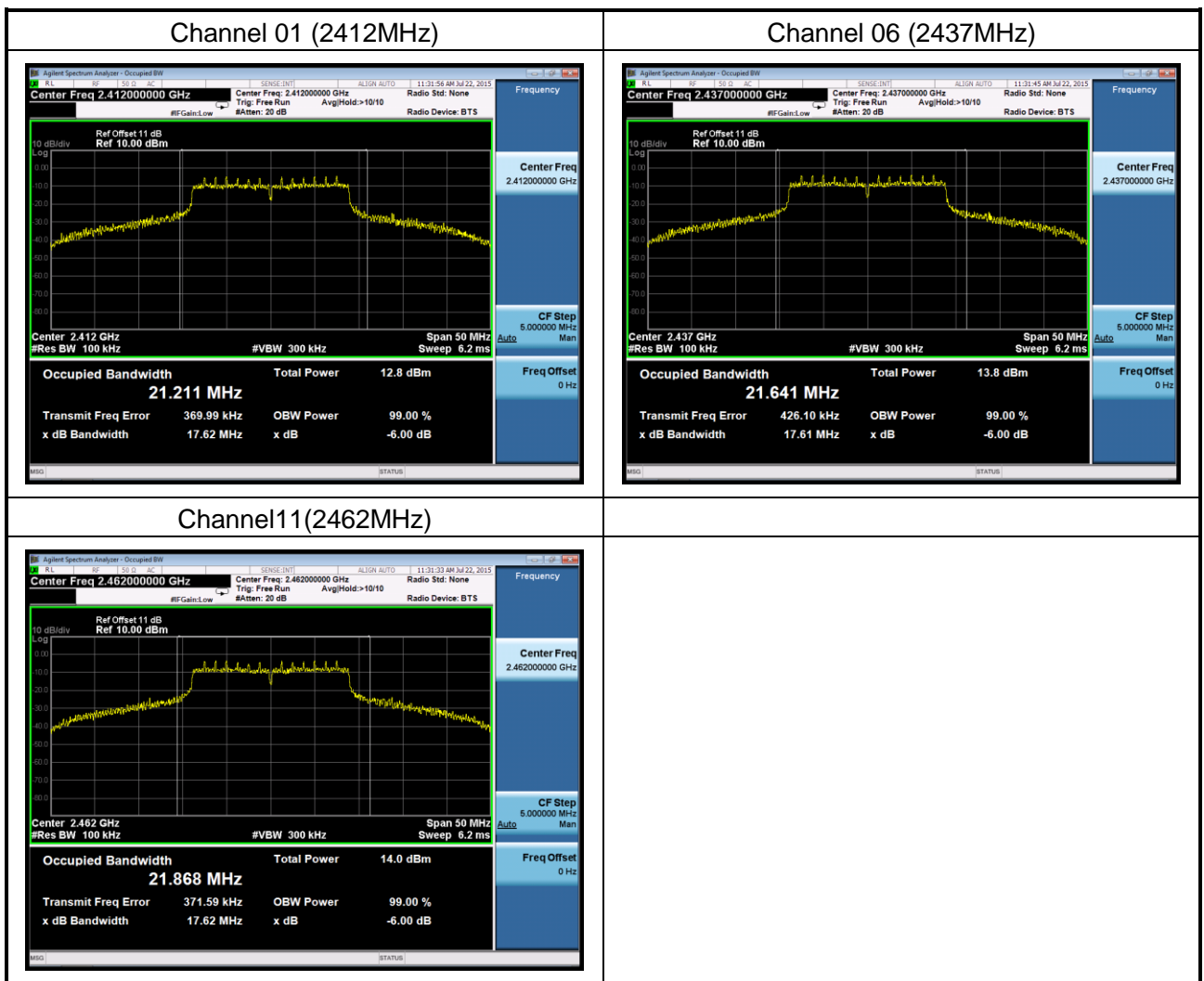



## 7. Maximum Output Power

### 7.1 Test Limit

The maximum power shall be less 1Watt (30dBm).

The conducted output power limits specified in §15.247(b) are based on the use of transmit antennae with directional gains that do not exceed 6 dBi. If transmit antennae with an effective directional gain greater than 6 dBi are used, then the conducted output power from the EUT shall be reduced as specified in §15.247(b) and (c).

Per RSS247 Issue 1 Section 5.4(4), for DTSs employing digital modulation techniques operating in the bands 902-928 MHz and 2400-2483.5 MHz, the maximum conducted output power shall not exceed 1W.

### 7.2 Test Procedure

The EUT was tested according to DTS test procedure of KDB 558074 for compliance to FCC 47CFR 15.247 requirements. The maximum conducted AVG output power using KDB 558074 D01v03r03 - Section 9.2.3.2 AVGPM-G Average Power Method.

### 7.3 Test Setup Layout

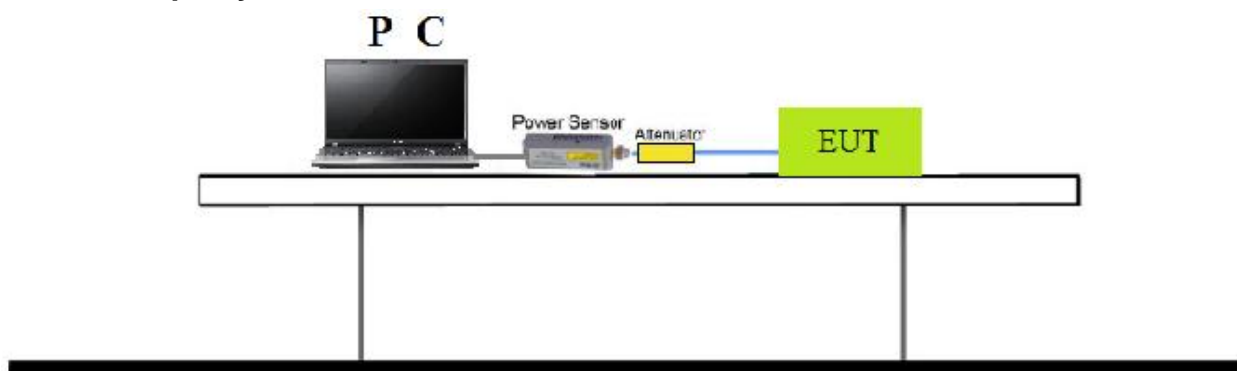

### 7.4 Measurement Equipment

Instrument	Manufacturer	Type No.	Serial No.	Calibration Date	Valid Date.
PC	Lenovo	E40-70	MP078UQV	N/A	N/A
POWER SENSOR	Agilent	U2021XA	MY53260020	2015/03/27	2016/03/26
Temperature/Humidity Meter	Zhicheng	ZC1-11	CEP-TH-003	2015.03.31	2016.03.30



### 7.5 Test Result and Data

Power output test was verified over all data rates of each mode shown as below, and then choose the maximum power output (blue marker) for final test of each channel.

MCS Index for 802.11n	Spatial Streams	Data Rate(Mbps)			
		802.11b	802.11g	20MHz Bandwidth	
				800ns GI	400ns GI
0	1	1	6	6.5	7.2
1	1	2	9	13.0	14.4
2	1	5.5	12	19.5	21.7
3	1	11	18	26.0	28.9
4	1	--	24	39.0	43.3
5	1	--	36	52.0	57.8
6	1	--	48	58.5	65.0
7	1	--	54	65.0	72.2
8	2	--	--	13.0	14.4
9	2	--	--	26.0	28.9
10	2	--	--	39.0	43.3
11	2	--	--	52.0	57.8
12	2	--	--	78.0	86.7
13	2	--	--	104.0	115.6
14	2	--	--	117.0	130.0
15	2	--	--	130.0	144.0





Test Item	Maximum Average Output Power
Test Mode	Transmit by 802.11b
Test Date	2015-07-22

Channel No.	Frequency (MHz)	Average Power (dBm)	Required Limit (dBm)	Result
01	2412	9.50	30	Pass
06	2437	10.03	30	Pass
11	2462	10.35	30	Pass

Test Item	Maximum Average Output Power
Test Mode	Transmit by 802.11g
Test Date	2015-07-22

Channel No.	Frequency (MHz)	Average Power (dBm)	Required Limit (dBm)	Result
01	2412	8.72	30	Pass
06	2437	9.43	30	Pass
11	2462	9.58	30	Pass

Test Item	Maximum Average Output Power
Test Mode	Transmit by 802.11n (20MHz)
Test Date	2015-07-22

Channel No.	Frequency (MHz)	Average Power (dBm)	Required Limit (dBm)	Result
01	2412	8.64	30	Pass
06	2437	9.42	30	Pass
11	2462	9.51	30	Pass



## 8. Band Edges Measurement

### 8.1 Test Limit

Below -20dB of the highest emission level of operating band (In 100 kHz Resolution Bandwidth)

### 8.2 Test Procedure

- The transmitter output was connected to the spectrum analyzer via a low lose cable.
- Set RBW of spectrum analyzer to 100 KHz and VBW of spectrum analyzer to 300 KHz with convenient frequency span including 100 KHz bandwidth from band edge.
- The band edges was measured and recorded.

### 8.3 Test Setup Layout

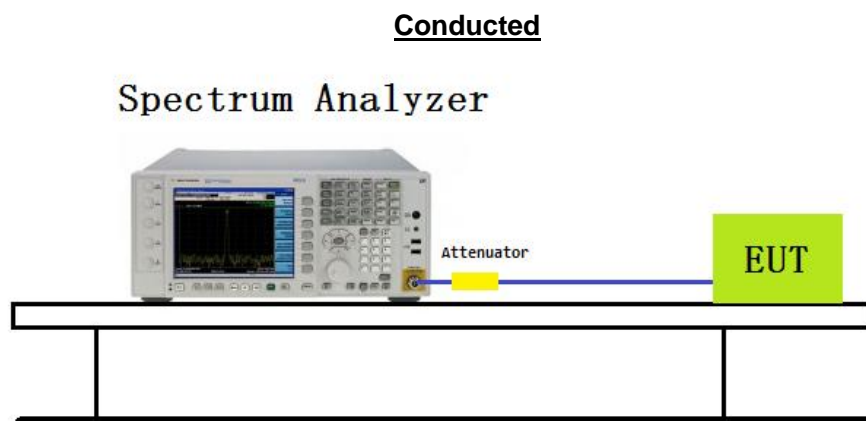
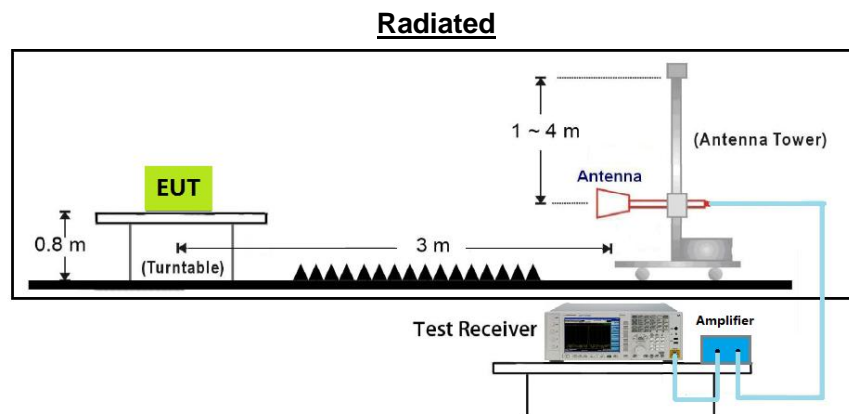

**8.4 Measurement Equipment**

Instrument/Ancillary	Manufacturer	Model No.	Serial No.	Calibration Date	Valid Date.
EMI Test Receiver	R&S	ESCI	100563	2015.02.10	2016.02.09
H64 Preamplifier	HP	8447F	3113A05582	2015.03.24	2016.03.23
Preamplifier	Agilent	8449B	3008A02342	2015.03.24	2016.03.23
Ultra Broadband Antenna	R&S	HL562	100362	2015.05.24	2016.05.23
Broad-Band Horn Antenna	Schwarzbeck	BBHA9120D	9120D-619	2015.05.24	2016.05.23
Broad-Band Horn Antenna	Schwarzbeck	BBHA9170	9170-348	2015.05.24	2016.05.23
Spectrum Analyzer	R&S	FSP40	100324	2015.03.23	2016.03.24
Spectrum Analyzer	N9010A	Agilent	MY54200207	2014.10.9	2015.10.08
Temperature/Humidity Meter	Zhicheng	ZC1-11	CEP-TH-002	2015.03.31	2016.03.30



Test Result and Data

Radiated

Site: AC102	Time: 2015/07/21
Limit: FCC_Part15.209_RE(3m)	Margin: 0
Probe: Horn_3117_00167055(1-18GHz)	Polarity: Horizontal
EUT: TE70SA3	Power: 120V/50Hz
Note: Mode1: Transmit at channel 2412MHz by 802.11b	

No	Mark	Frequency (MHz)	Measure Level (dBuV/m)	Reading Level (dBuV)	Over Limit (dB)	Limit (dBuV/m)	Factor (dB)	Type
1		2390.000	61.020	29.216	-12.980	74.000	31.804	PK
2	*	2410.800	106.03	74.15	N/A	N/A	31.879	PK

Site: AC102	Time: 2015/07/21
Limit: FCC_Part15.209_RE(3m)	Margin: 0
Probe: Horn_3117_00167055(1-18GHz)	Polarity: Horizontal
EUT: TE70SA3	Power: 120V/50Hz
Note: Mode1: Transmit at channel 2412MHz by 802.11b	

No	Mark	Frequency (MHz)	Measure Level (dBuV/m)	Reading Level (dBuV)	Over Limit (dB)	Limit (dBuV/m)	Factor (dB)	Type
1		2390.000	47.712	15.908	-6.288	54.000	31.804	AV
2	*	2412.704	90.101	58.215	N/A	N/A	31.886	AV

Site: AC102	Time: 2015/07/21
Limit: FCC_Part15.209_RE(3m)	Margin: 0
Probe: Horn_3117_00167055(1-18GHz)	Polarity: Vertical
EUT: TE70SA3	Power: 120V/50Hz
Note: Mode1: Transmit at channel 2412MHz by 802.11b	

No	Mark	Frequency (MHz)	Measure Level (dBuV/m)	Reading Level (dBuV)	Over Limit (dB)	Limit (dBuV/m)	Factor (dB)	Type
1		2390.000	60.356	28.552	-13.644	74.000	31.804	PK
2	*	2410.576	89.788	57.910	N/A	N/A	31.878	PK



Site: AC102	Time: 2015/07/21
Limit: FCC_Part15.209_RE(3m)	Margin: 0
Probe: Horn_3117_00167055(1-18GHz)	Polarity: Vertical
EUT: TE70SA3	Power: 120V/50Hz
Note: Mode1: Transmit at channel 2412MHz by 802.11b	

No	Mark	Frequency (MHz)	Measure Level (dBuV/m)	Reading Level (dBuV)	Over Limit (dB)	Limit (dBuV/m)	Factor (dB)	Type
1		2390.000	47.730	15.926	-6.270	54.000	31.804	AV
2	*	2411.472	84.756	52.874	N/A	N/A	31.882	AV

Site: AC102	Time: 2015/07/21
Limit: FCC_Part15.209_RE(3m)	Margin: 0
Probe: Horn_3117_00167055(1-18GHz)	Polarity: Horizontal
EUT: TE70SA3	Power: 120V/50Hz
Note: Mode1: Transmit at channel 2462MHz by 802.11b	

No	Mark	Frequency (MHz)	Measure Level (dBuV/m)	Reading Level (dBuV)	Over Limit (dB)	Limit (dBuV/m)	Factor (dB)	Type
1	*	2463.424	106.88	74.81	N/A	N/A	32.068	PK
2		2483.500	62.239	30.099	-11.761	74.000	32.140	PK

Site: AC102	Time: 2015/07/21
Limit: FCC_Part15.209_RE(3m)	Margin: 0
Probe: Horn_3117_00167055(1-18GHz)	Polarity: Horizontal
EUT: TE70SA3	Power: 120V/50Hz
Note: Mode1: Transmit at channel 2462MHz by 802.11b	

No	Mark	Frequency (MHz)	Measure Level (dBuV/m)	Reading Level (dBuV)	Over Limit (dB)	Limit (dBuV/m)	Factor (dB)	Type
1	*	2462.896	94.137	62.071	N/A	N/A	32.066	AV
2		2483.500	49.619	17.479	-4.381	54.000	32.140	AV



Site: AC102	Time: 2015/07/21
Limit: FCC_Part15.209_RE(3m)	Margin: 0
Probe: Horn_3117_00167055(1-18GHz)	Polarity: Vertical
EUT: TE70SA3	Power: 120V/50Hz
Note: Mode1: Transmit at channel 2462MHz by 802.11b	

No	Mark	Frequency (MHz)	Measure Level (dBuV/m)	Reading Level (dBuV)	Over Limit (dB)	Limit (dBuV/m)	Factor (dB)	Type
1	*	2463.040	98.657	66.590	N/A	N/A	32.067	PK
2		2483.500	61.929	29.789	-12.071	74.000	32.140	PK

Site: AC102	Time: 2015/07/21
Limit: FCC_Part15.209_RE(3m)	Margin: 0
Probe: Horn_3117_00167055(1-18GHz)	Polarity: Vertical
EUT: TE70SA3	Power: 120V/50Hz
Note: Mode1: Transmit at channel 2462MHz by 802.11b	

No	Mark	Frequency (MHz)	Measure Level (dBuV/m)	Reading Level (dBuV)	Over Limit (dB)	Limit (dBuV/m)	Factor (dB)	Type
1	*	2462.800	92.344	60.278	N/A	N/A	32.066	AV
2		2483.500	49.088	16.948	-4.912	54.000	32.140	AV

Site: AC102	Time: 2015/07/21
Limit: FCC_Part15.209_RE(3m)	Margin: 0
Probe: Horn_3117_00167055(1-18GHz)	Polarity: Horizontal
EUT: TE70SA3	Power: 120V/50Hz
Note: Mode2: Transmit at channel 2412MHz by 802.11g	

No	Mark	Frequency (MHz)	Measure Level (dBuV/m)	Reading Level (dBuV)	Over Limit (dB)	Limit (dBuV/m)	Factor (dB)	Type
1		2390.000	72.438	40.634	-1.562	74.000	31.804	PK
2	*	2405.312	105.25	73.39	N/A	N/A	31.859	PK



Site: AC102	Time: 2015/07/21
Limit: FCC_Part15.209_RE(3m)	Margin: 0
Probe: Horn_3117_00167055(1-18GHz)	Polarity: Horizontal
EUT: TE70SA3	Power: 120V/50Hz
Note: Mode2: Transmit at channel 2412MHz by 802.11g	

No	Mark	Frequency (MHz)	Measure Level (dBuV/m)	Reading Level (dBuV)	Over Limit (dB)	Limit (dBuV/m)	Factor (dB)	Type
1		2390.000	53.200	21.396	-0.800	54.000	31.804	AV
2	*	2405.536	83.172	51.312	N/A	N/A	31.860	AV

Site: AC102	Time: 2015/07/21
Limit: FCC_Part15.209_RE(3m)	Margin: 0
Probe: Horn_3117_00167055(1-18GHz)	Polarity: Vertical
EUT: TE70SA3	Power: 120V/50Hz
Note: Mode2: Transmit at channel 2412MHz by 802.11g	

No	Mark	Frequency (MHz)	Measure Level (dBuV/m)	Reading Level (dBuV)	Over Limit (dB)	Limit (dBuV/m)	Factor (dB)	Type
1		2390.000	70.807	39.003	-3.193	74.000	31.804	PK
2	*	2418.080	98.121	66.216	N/A	N/A	31.905	PK

Site: AC102	Time: 2015/07/21
Limit: FCC_Part15.209_RE(3m)	Margin: 0
Probe: Horn_3117_00167055(1-18GHz)	Polarity: Vertical
EUT: TE70SA3	Power: 120V/50Hz
Note: Mode2: Transmit at channel 2412MHz by 802.11g	

No	Mark	Frequency (MHz)	Measure Level (dBuV/m)	Reading Level (dBuV)	Over Limit (dB)	Limit (dBuV/m)	Factor (dB)	Type
1		2390.000	52.304	20.500	-1.696	54.000	31.804	AV
2	*	2405.536	82.907	51.047	N/A	N/A	31.860	AV



Site: AC102	Time: 2015/07/21
Limit: FCC_Part15.209_RE(3m)	Margin: 0
Probe: Horn_3117_00167055(1-18GHz)	Polarity: Horizontal
EUT: TE70SA3	Power: 120V/50Hz
Note: Mode2: Transmit at channel 2462MHz by 802.11g	

No	Mark	Frequency (MHz)	Measure Level (dBuV/m)	Reading Level (dBuV)	Over Limit (dB)	Limit (dBuV/m)	Factor (dB)	Type
1	*	2469.328	106.11	74.02	N/A	N/A	32.089	PK
2		2483.500	73.444	41.304	-0.556	74.000	32.140	PK

Site: AC102	Time: 2015/07/21
Limit: FCC_Part15.209_RE(3m)	Margin: 0
Probe: Horn_3117_00167055(1-18GHz)	Polarity: Horizontal
EUT: TE70SA3	Power: 120V/50Hz
Note: Mode2: Transmit at channel 2462MHz by 802.11g	

No	Mark	Frequency (MHz)	Measure Level (dBuV/m)	Reading Level (dBuV)	Over Limit (dB)	Limit (dBuV/m)	Factor (dB)	Type
1	*	2469.472	82.152	50.062	N/A	N/A	32.090	AV
2		2483.500	52.055	19.915	-1.945	54.000	32.140	AV

Site: AC102	Time: 2015/07/21
Limit: FCC_Part15.209_RE(3m)	Margin: 0
Probe: Horn_3117_00167055(1-18GHz)	Polarity: Vertical
EUT: TE70SA3	Power: 120V/50Hz
Note: Mode2: Transmit at channel 2462MHz by 802.11g	

No	Mark	Frequency (MHz)	Measure Level (dBuV/m)	Reading Level (dBuV)	Over Limit (dB)	Limit (dBuV/m)	Factor (dB)	Type
1	*	2468.704	95.623	63.536	N/A	N/A	32.087	PK
2		2483.500	70.781	38.641	-3.219	74.000	32.140	PK
3		2483.728	73.010	40.869	-0.990	74.000	32.141	PK





Site: AC102	Time: 2015/07/21
Limit: FCC_Part15.209_RE(3m)	Margin: 0
Probe: Horn_3117_00167055(1-18GHz)	Polarity: Vertical
EUT: TE70SA3	Power: 120V/50Hz
Note: Mode2: Transmit at channel 2462MHz by 802.11g	

No	Mark	Frequency (MHz)	Measure Level (dBuV/m)	Reading Level (dBuV)	Over Limit (dB)	Limit (dBuV/m)	Factor (dB)	Type
1	*	2469.568	80.825	48.735	N/A	N/A	32.090	AV
2		2483.500	51.512	19.372	-2.488	54.000	32.140	AV

Site: AC102	Time: 2015/07/21
Limit: FCC_Part15.209_RE(3m)	Margin: 0
Probe: Horn_3117_00167055(1-18GHz)	Polarity: Horizontal
EUT: TE70SA3	Power: 120V/50Hz
Note: Mode3: Transmit at channel 2412MHz by 802.11n20	

No	Mark	Frequency (MHz)	Measure Level (dBuV/m)	Reading Level (dBuV)	Over Limit (dB)	Limit (dBuV/m)	Factor (dB)	Type
1		2389.632	73.314	41.512	-0.686	74.000	31.802	PK
2	*	2405.200	105.17	73.31	N/A	N/A	31.859	PK

Site: AC102	Time: 2015/07/21
Limit: FCC_Part15.209_RE(3m)	Margin: 0
Probe: Horn_3117_00167055(1-18GHz)	Polarity: Horizontal
EUT: TE70SA3	Power: 120V/50Hz
Note: Mode3: Transmit at channel 2412MHz by 802.11n20	

No	Mark	Frequency (MHz)	Measure Level (dBuV/m)	Reading Level (dBuV)	Over Limit (dB)	Limit (dBuV/m)	Factor (dB)	Type
1		2390.000	53.860	22.056	-0.140	54.000	31.804	AV
2	*	2405.536	82.944	51.084	N/A	N/A	31.860	AV



Site: AC102	Time: 2015/07/21
Limit: FCC_Part15.209_RE(3m)	Margin: 0
Probe: Horn_3117_00167055(1-18GHz)	Polarity: Vertical
EUT: TE70SA3	Power: 120V/50Hz
Note: Mode3: Transmit at channel 2412MHz by 802.11n20	

No	Mark	Frequency (MHz)	Measure Level (dBuV/m)	Reading Level (dBuV)	Over Limit (dB)	Limit (dBuV/m)	Factor (dB)	Type
1		2390.000	68.610	36.806	-5.390	74.000	31.804	PK
2	*	2405.312	93.803	61.944	N/A	N/A	31.859	PK

Site: AC102	Time: 2015/07/21
Limit: FCC_Part15.209_RE(3m)	Margin: 0
Probe: Horn_3117_00167055(1-18GHz)	Polarity: Vertical
EUT: TE70SA3	Power: 120V/50Hz
Note: Mode3: Transmit at channel 2412MHz by 802.11n20	

No	Mark	Frequency (MHz)	Measure Level (dBuV/m)	Reading Level (dBuV)	Over Limit (dB)	Limit (dBuV/m)	Factor (dB)	Type
1		2390.000	51.712	19.908	-2.288	54.000	31.804	AV
2	*	2419.312	80.616	48.706	N/A	N/A	31.910	AV

Site: AC102	Time: 2015/07/21
Limit: FCC_Part15.209_RE(3m)	Margin: 0
Probe: Horn_3117_00167055(1-18GHz)	Polarity: Horizontal
EUT: TE70SA3	Power: 120V/50Hz
Note: Mode3: Transmit at channel 2462MHz by 802.11n20	

No	Mark	Frequency (MHz)	Measure Level (dBuV/m)	Reading Level (dBuV)	Over Limit (dB)	Limit (dBuV/m)	Factor (dB)	Type
1	*	2469.136	106.04	74.18	N/A	N/A	32.089	PK
2		2483.500	71.906	39.766	-2.094	74.000	32.140	PK



Site: AC102	Time: 2015/07/21
Limit: FCC_Part15.209_RE(3m)	Margin: 0
Probe: Horn_3117_00167055(1-18GHz)	Polarity: Horizontal
EUT: TE70SA3	Power: 120V/50Hz
Note: Mode3: Transmit at channel 2462MHz by 802.11n20	

No	Mark	Frequency (MHz)	Measure Level (dBuV/m)	Reading Level (dBuV)	Over Limit (dB)	Limit (dBuV/m)	Factor (dB)	Type
1	*	2468.944	81.222	49.134	27.222	54.000	32.088	AV
2		2483.500	52.762	20.622	N/A	N/A	32.140	AV

Site: AC102	Time: 2015/07/21
Limit: FCC_Part15.209_RE(3m)	Margin: 0
Probe: Horn_3117_00167055(1-18GHz)	Polarity: Vertical
EUT: TE70SA3	Power: 120V/50Hz
Note: Mode3: Transmit at channel 2462MHz by 802.11n20	

No	Mark	Frequency (MHz)	Measure Level (dBuV/m)	Reading Level (dBuV)	Over Limit (dB)	Limit (dBuV/m)	Factor (dB)	Type
1	*	2469.040	95.055	62.967	21.055	74.000	32.088	PK
2		2483.500	70.648	38.508	N/A	N/A	32.140	PK

Site: AC102	Time: 2015/07/21
Limit: FCC_Part15.209_RE(3m)	Margin: 0
Probe: Horn_3117_00167055(1-18GHz)	Polarity: Vertical
EUT: TE70SA3	Power: 120V/50Hz
Note: Mode3: Transmit at channel 2462MHz by 802.11n20	

No	Mark	Frequency (MHz)	Measure Level (dBuV/m)	Reading Level (dBuV)	Over Limit (dB)	Limit (dBuV/m)	Factor (dB)	Type
1	*	2469.040	79.668	47.580	N/A	N/A	32.088	AV
2		2483.500	51.380	19.240	-2.620	54.000	32.140	AV



### Band Edge (20dBc RF Conducted Measurement)

Mode 1: Transmit by 802.11b (2412MHz)

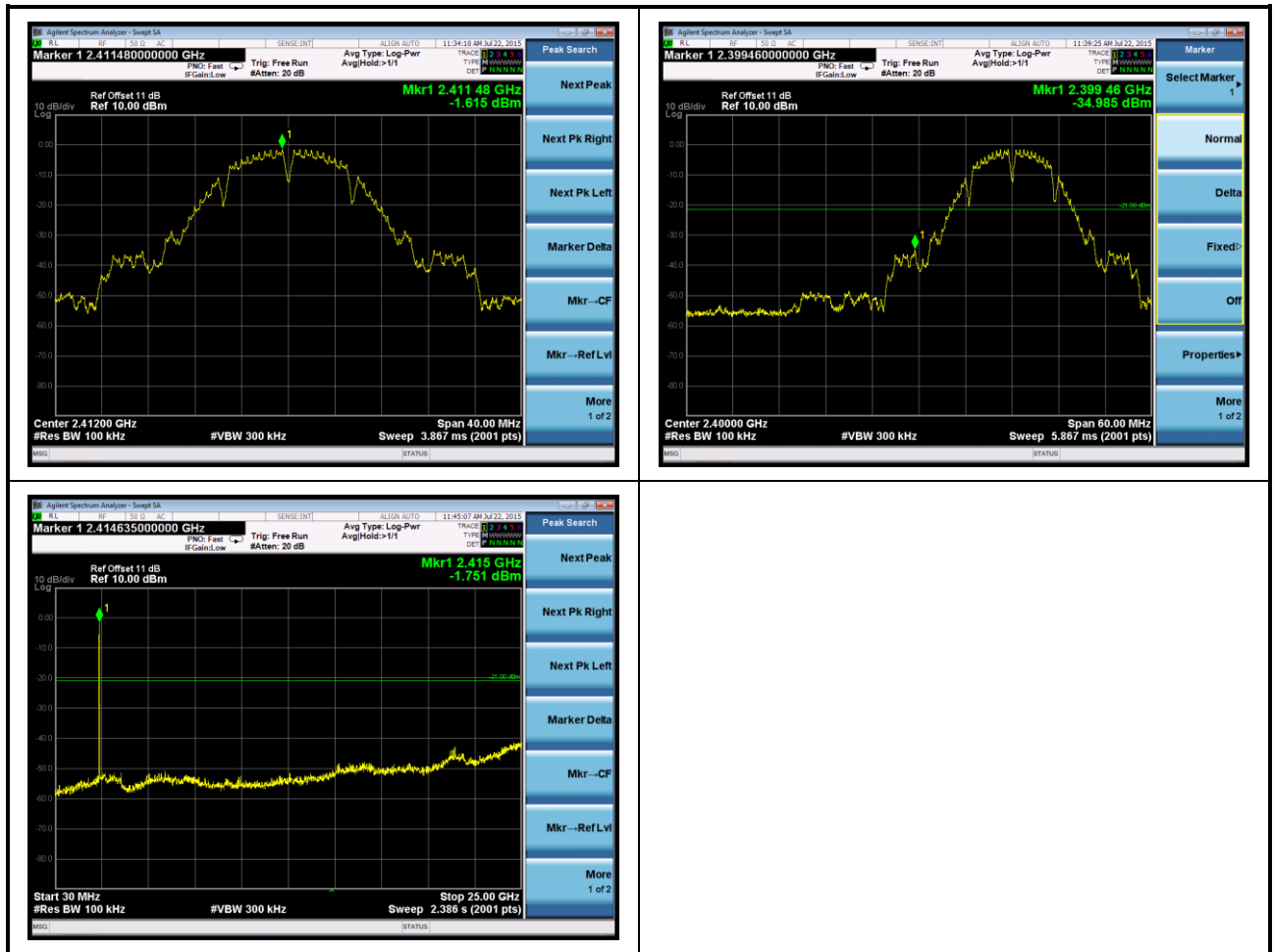



Mode 1: Transmit by 802.11b (2437MHz)



Mode 1: Transmit by 802.11b (2462MHz)

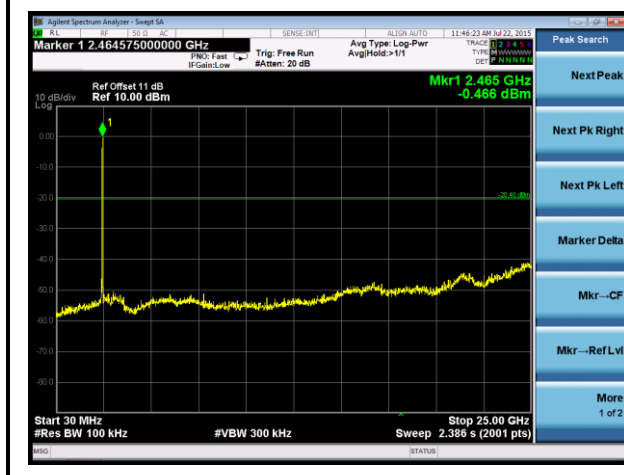
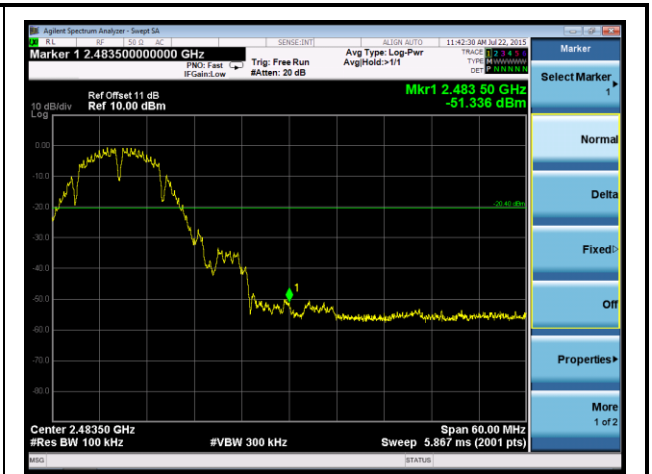
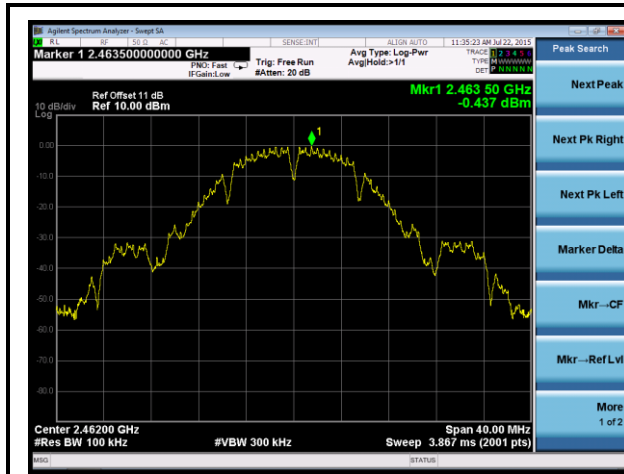



Mode 2: Transmit by 802.11g (2412MHz)

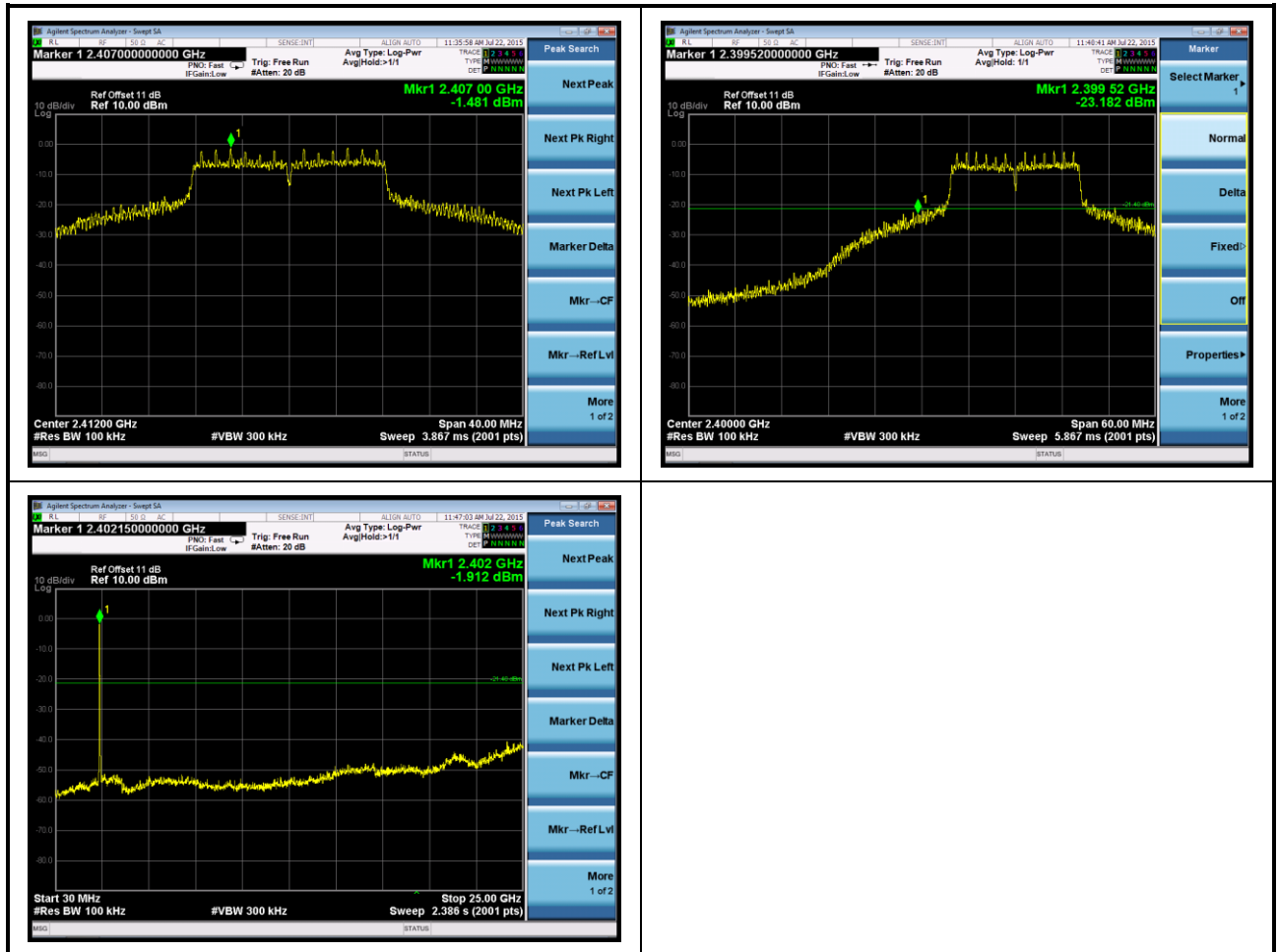



Mode 2: Transmit by 802.11g (2437MHz)

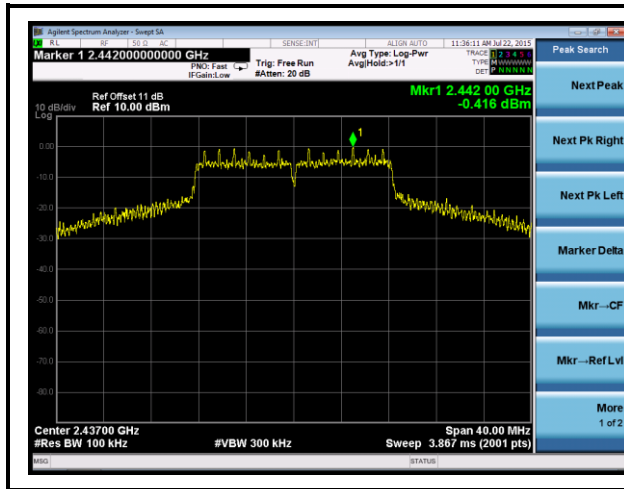

Mode 2: Transmit by 802.11g (2462MHz)

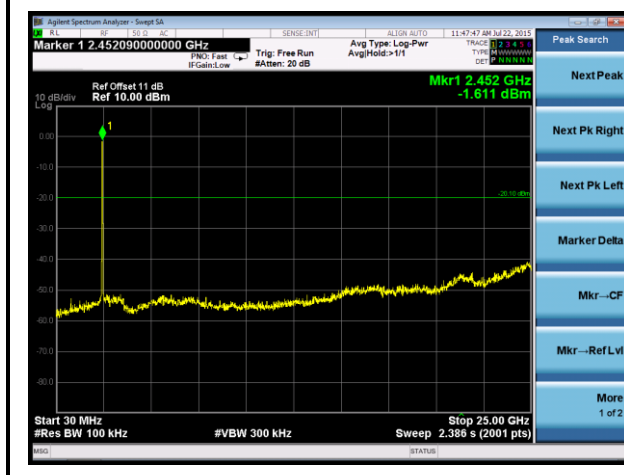
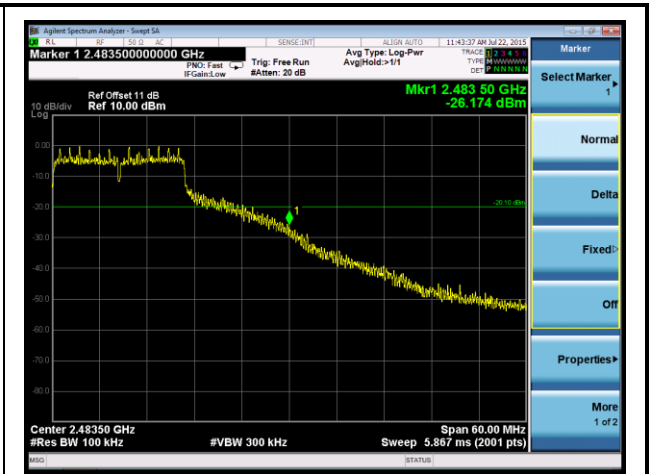
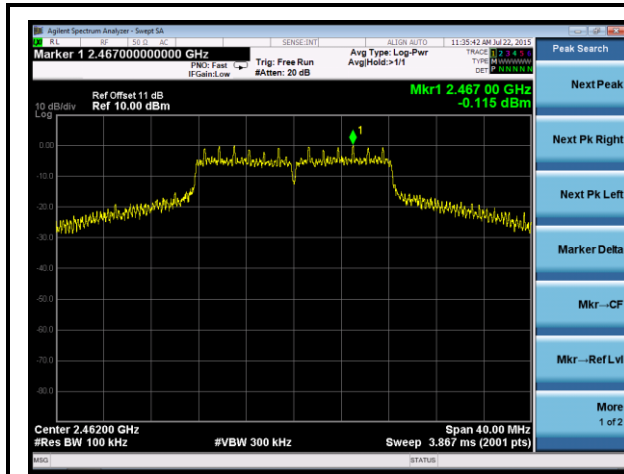



Mode 3: Transmit by 802.11n20 (2412MHz)

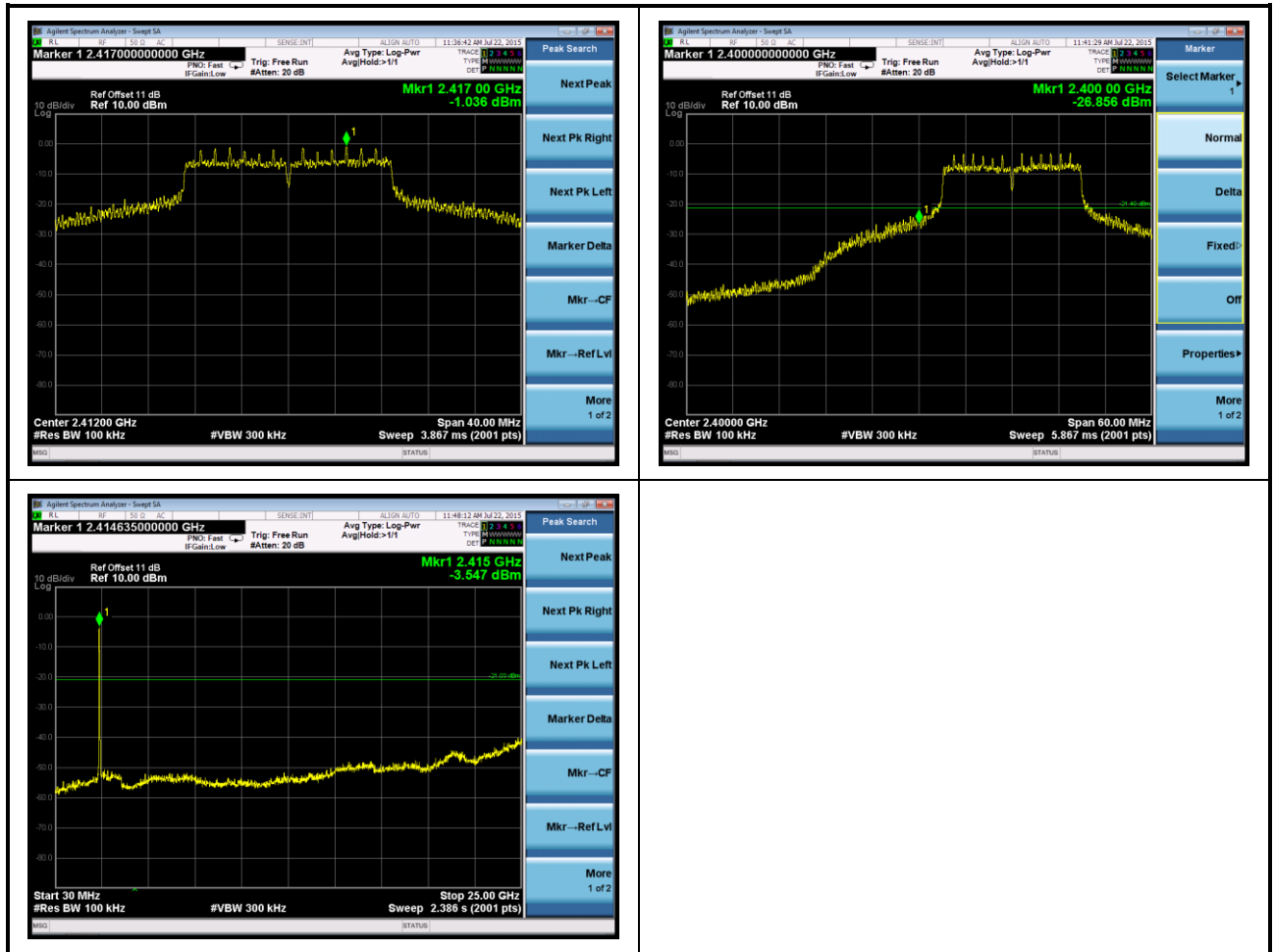





Mode 3: Transmit by 802.11n20 (2437MHz)

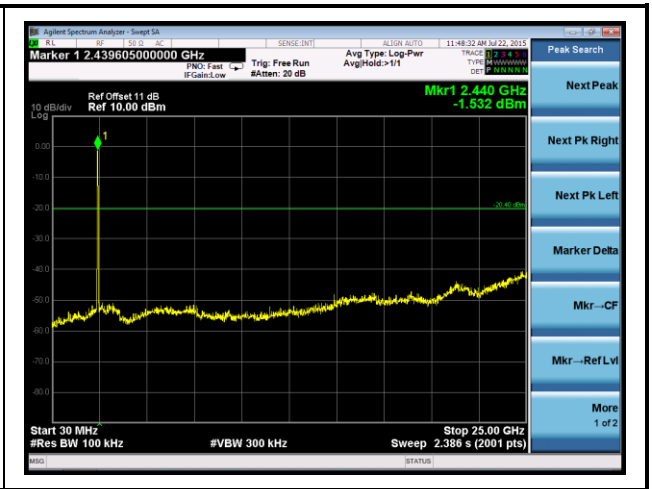
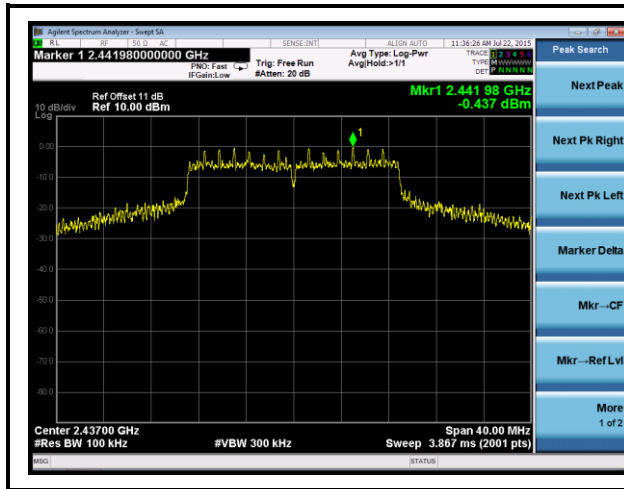

Mode 3: Transmit by 802.11n20 (2462MHz)

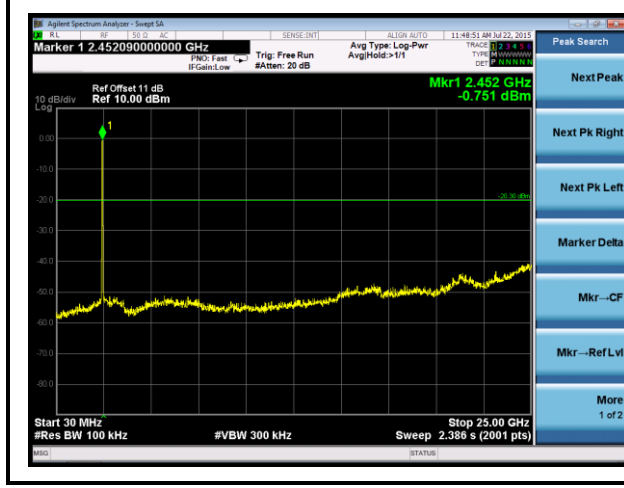
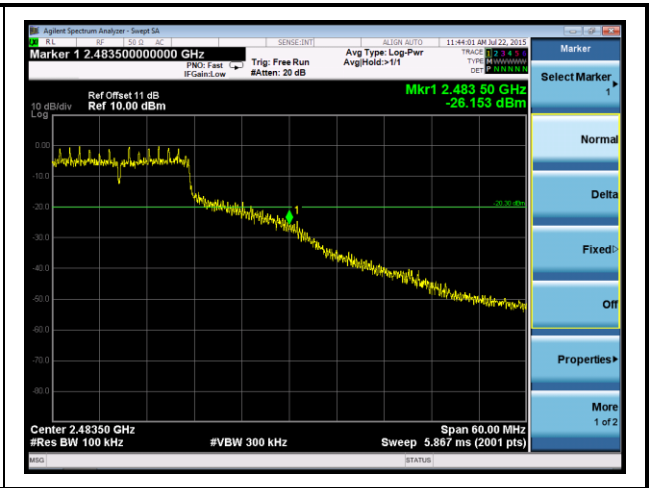
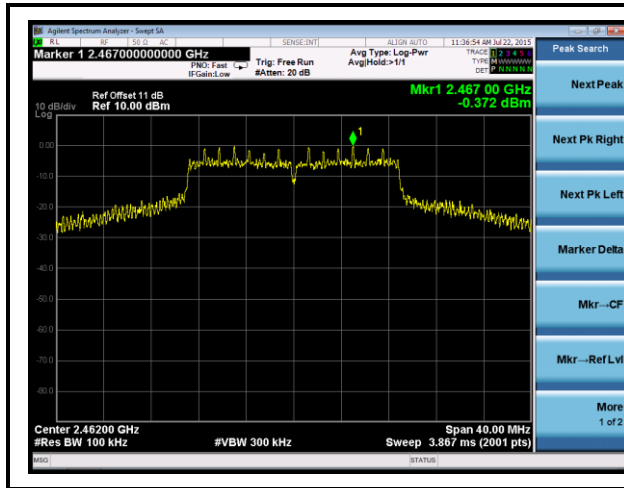



## 9. Power Spectral Density

### 9.1 Test Limit

The Maximum of Power Spectral Density Measurement is 8dBm.

### 9.2 Test Procedure

The EUT was setup according to ANSI C63.10, 2013; tested according to DTS test procedure of KDB 558074 for compliance to FCC 47CFR 15.247 requirements.

The maximum power spectral density using KDB 558074 section 10.2 PKPSD (peak PSD) method.

- a) Set analyzer center frequency to DTS channel center frequency.
- b) Set the span to 1.5 times the DTS bandwidth.
- c) Set the RBW to:  $3\text{ kHz} \leq \text{RBW} \leq 100\text{ kHz}$ . (Actually we use 3kHz RBW)
- d) Set the VBW  $\geq 3 \times \text{RBW}$ .
- e) Detector = peak.
- f) Sweep time = auto couple.
- g) Trace mode = max hold.
- h) Allow trace to fully stabilize.
- i) Use the peak marker function to determine the maximum amplitude level within the band.
- j) If measured value exceeds limit, reduce RBW (no less than 3 kHz) and repeat.

### 9.3 Test Setup Layout

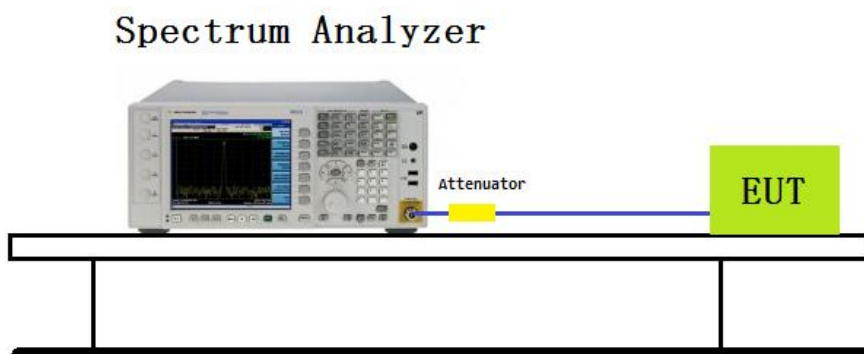

### 9.4 Measurement Equipment

Instrument/Ancillary	Model No.	Manufacturer	Serial No.	Calibration Date	Valid Date
Spectrum Analyzer	N9010A	Agilent	MY54200207	2014/10/9	2015/10/08



### 9.5 Test Result and Data

Test Item	Power Spectral Density
Test Mode	Transmit by 802.11b
Test Date	2015-07-22

Channel	Frequency (MHz)	Power Spectral Density (dBm/3kHz)	Limit (dBm/3kHz)	Result
01	2412	-15.993	8	Pass
06	2437	-14.526	8	Pass
11	2462	-14.764	8	Pass

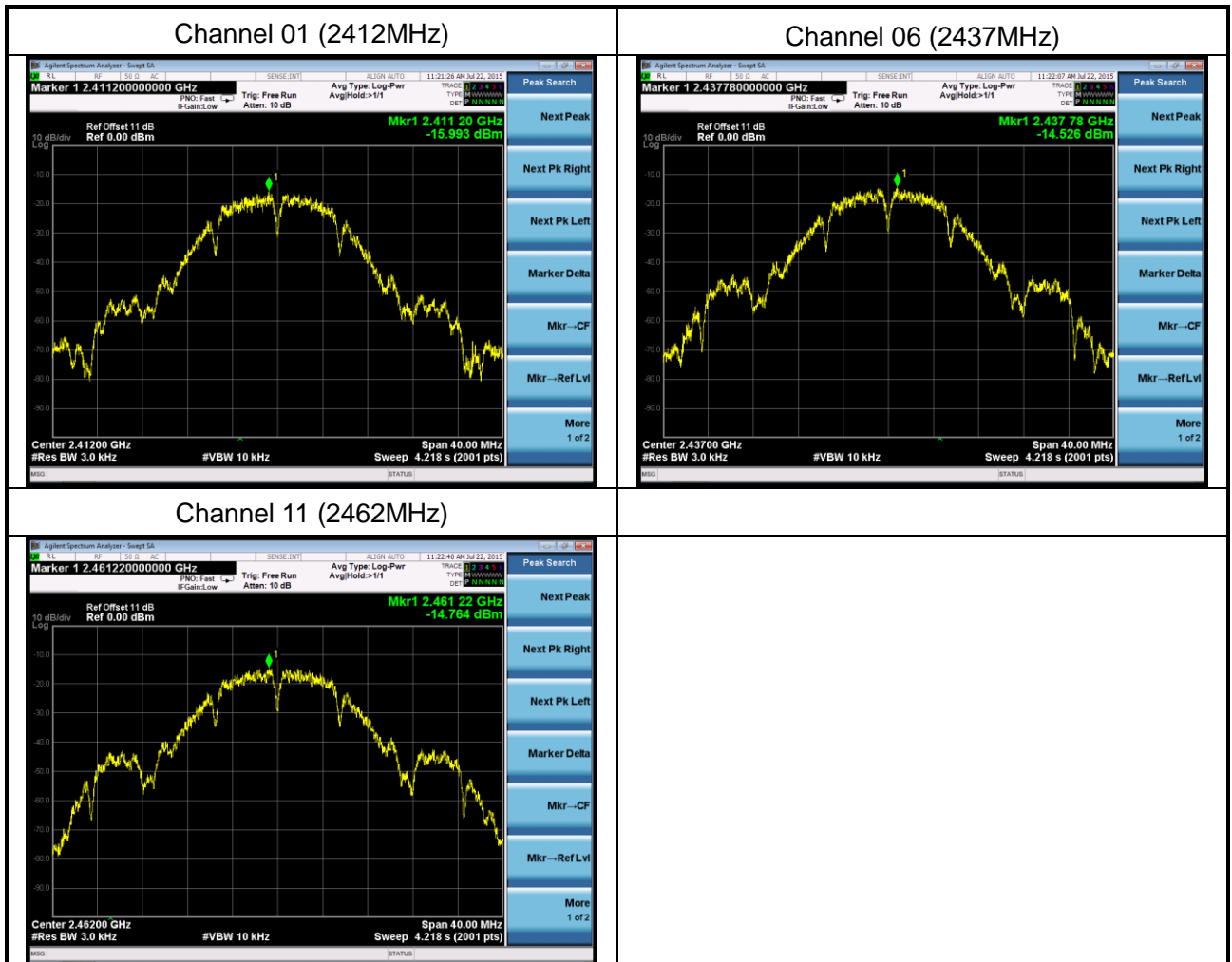



Test Item	Power Spectral Density
Test Mode	Transmit by 802.11g
Test Date	2015-07-22

Channel	Frequency (MHz)	Power Spectral Density (dBm/3kHz)	Limit (dBm/3kHz)	Result
01	2412	-17.103	8	Pass
06	2437	-15.703	8	Pass
11	2462	-16.451	8	Pass

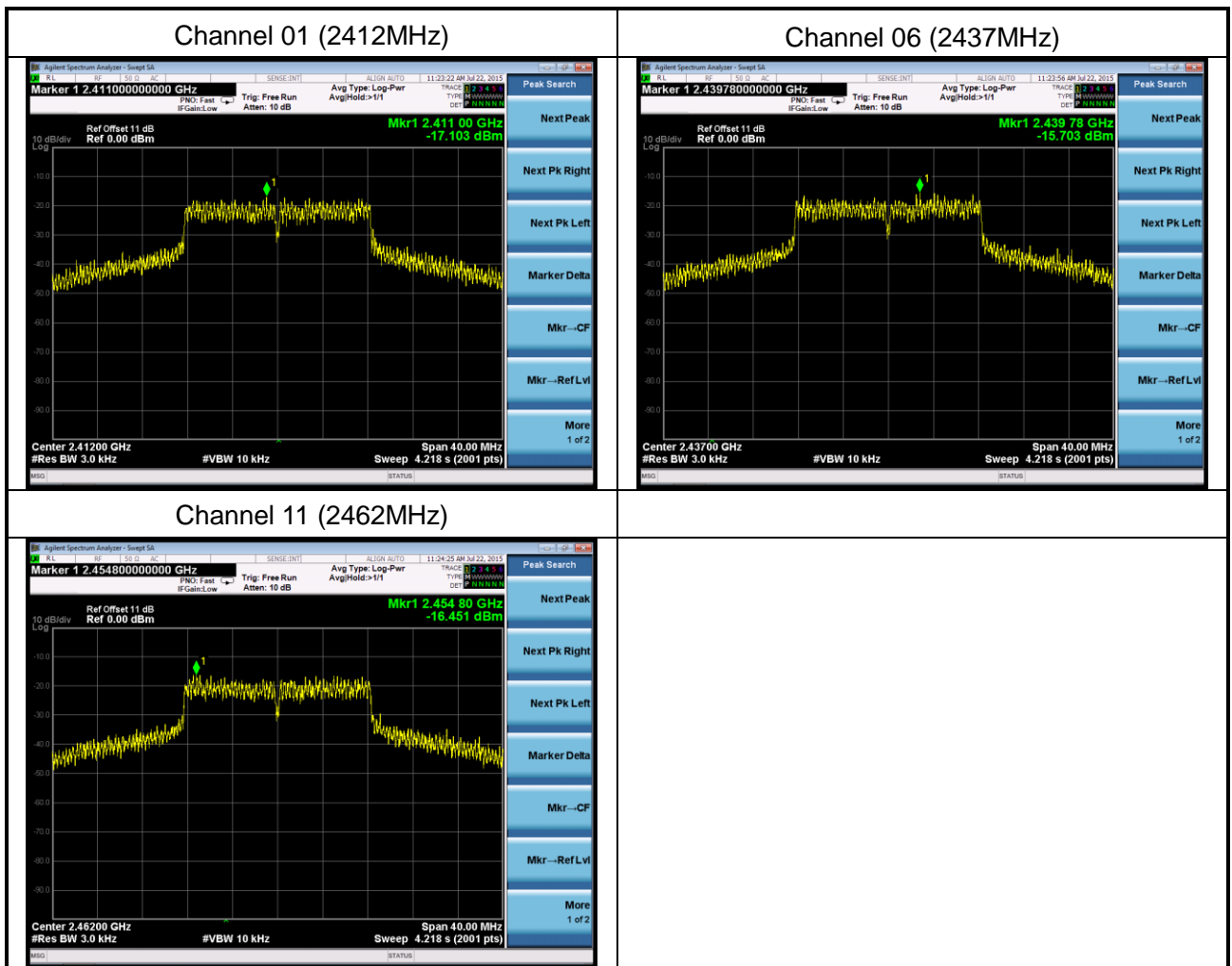



Test Item	Power Spectral Density
Test Mode	Transmit by 802.11n (20MHz)
Test Date	2015-07-22

Channel	Frequency (MHz)	Power Spectral Density (dBm/3kHz)	Limit (dBm/3kHz)	Result
01	2412	-17.351	8	Pass
06	2437	-15.542	8	Pass
11	2462	-16.061	8	Pass

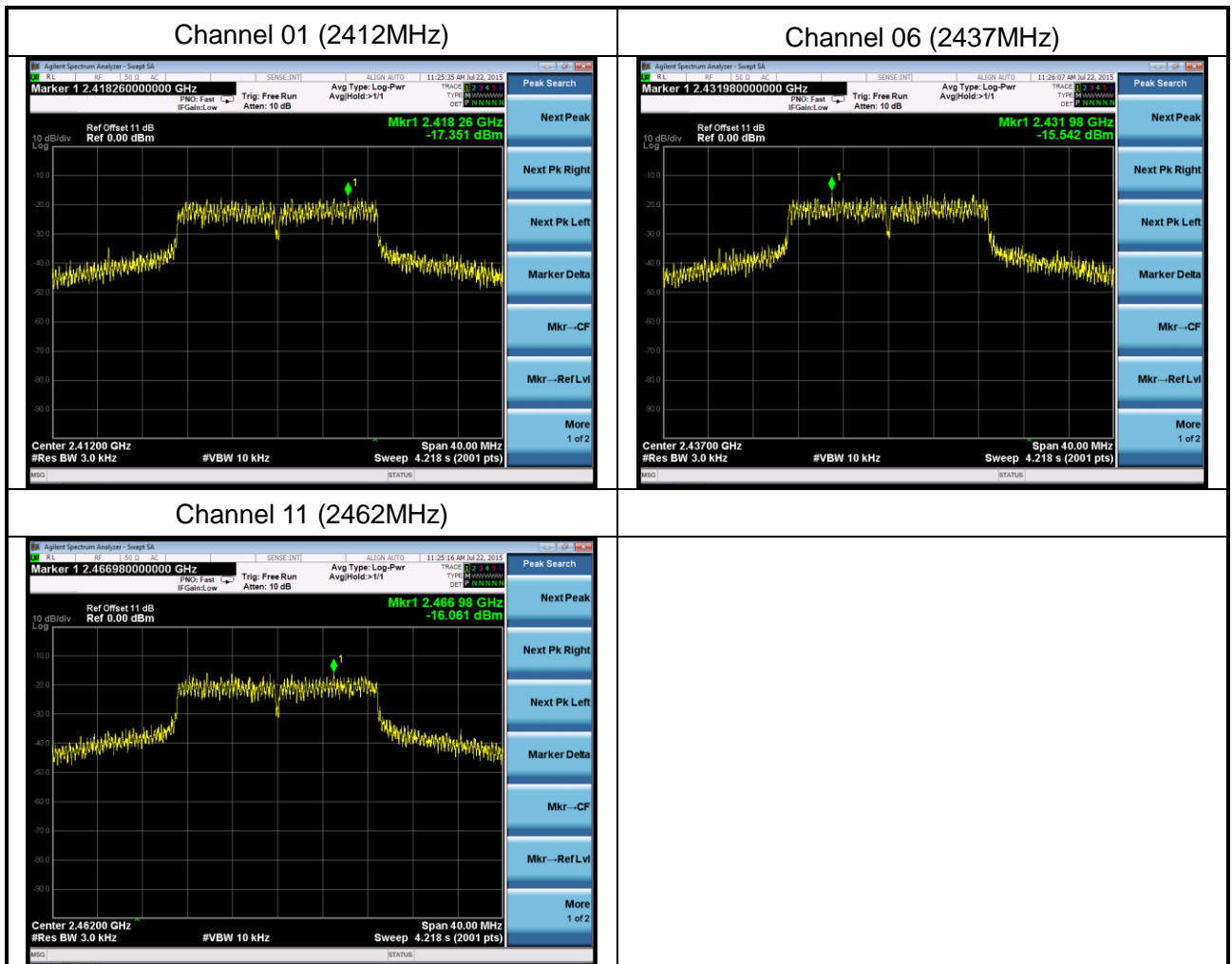



### 10. Restricted Bands of Operation

Only spurious emissions are permitted in any of the frequency bands listed below:

MHz	MHz	MHz	GHz
0.09000 – 0.11000	16.42000 – 16.42300	399.9 – 410.0	4.500 – 5.250
0.49500 – 0.505**	16.69475 – 16.69525	608.0 – 614.0	5.350 – 5.460
2.17350 – 2.19050	16.80425 – 16.80475	960.0 – 1240.0	7.250 – 7.750
4.12500 – 4.12800	25.50000 – 25.67000	1300.0 – 1427.0	8.025 – 8.500
4.17725 – 4.17775	37.50000 – 38.25000	1435.0 – 1626.5	9.000 – 9.200
4.20725 – 4.20775	73.00000 – 74.60000	1645.5 – 1646.5	9.300 – 9.500
6.21500 – 6.21800	74.80000 – 75.20000	1660.0 – 1710.0	10.600 – 12.700
6.26775 – 6.26825	108.00000 – 121.94000	1718.8 – 1722.2	13.250 – 13.400
6.31175 – 6.31225	123.00000 – 138.00000	2200.0 – 2300.0	14.470 – 14.500
8.29100 – 8.29400	149.90000 – 150.05000	2310.0 – 2390.0	15.350 – 16.200
8.36200 – 8.36600	156.52475 – 156.52525	2483.5 – 2500.0	17.700 – 21.400
8.37625 – 8.38675	156.70000 – 156.90000	2655.0 – 2900.0	22.010 – 23.120
8.41425 – 8.41475	162.01250 – 167.17000	3260.0 – 3267.0	23.600 – 24.000
12.29000 – 12.29300	167.72000 – 173.20000	3332.0 – 3339.0	31.200 – 31.800
12.51975 – 12.52025	240.00000 – 285.00000	3345.8 – 3358.0	36.430 – 36.500
12.57675 – 12.57725	322.00000 – 335.40000	3600.0 – 4400.0	Above 38.6
13.36000 – 13.41000			

\*\* : Until February 1, 1999, this restricted band shall be 0.490-0.510 MHz

#### 10.1 Labeling Requirement

The device shall bear the following statement in a conspicuous location on the device:

This device complies with part 15 of the FCC Rules. Operation is subject to the following two conditions:

- (1) This device may not cause harmful interference, and
- (2) this device must accept any interference received, including interference that may cause undesired operation.