

Test Plot 1#: Ant 1(AF701)_PTT FM_Face Up_136.0125 MHz_ PH790 VHF

DUT: DIGITAL PORTABLE RADIO; Type: PH790 VHF; Serial: 18080900821

Communication System: FM; Frequency: 136.012 MHz;Duty Cycle: 1:1

Medium parameters used: $f = 136.012$ MHz; $\sigma = 0.726$ S/m; $\epsilon_r = 52.929$; $\rho = 1000$ kg/m³

Phantom section: Flat Section

DASY5 Configuration:

- Probe: EX3DV4 - SN7329; ConvF(12.88, 12.88, 12.88); Calibrated: 2018/1/22;
- Sensor-Surface: 1.4mm (Mechanical Surface Detection)
- Electronics: DAE4 Sn1459; Calibrated: 2017/9/15
- Phantom: ELI v8.0; Type: QDOVA004AA; Serial: 2051
- Measurement SW: DASY52, Version 52.8 (8);

Area Scan (71x161x1): Interpolated grid: dx=1.500 mm, dy=1.500 mm

Maximum value of SAR (interpolated) = 3.23 W/kg

Zoom Scan (5x6x7)/Cube 0: Measurement grid: dx=8mm, dy=8mm, dz=5mm

Reference Value = 56.38 V/m; Power Drift = -0.10 dB

Peak SAR (extrapolated) = 4.09 W/kg

SAR(1 g) = 2.49 W/kg; SAR(10 g) = 1.86 W/kg

Maximum value of SAR (measured) = 3.40 W/kg

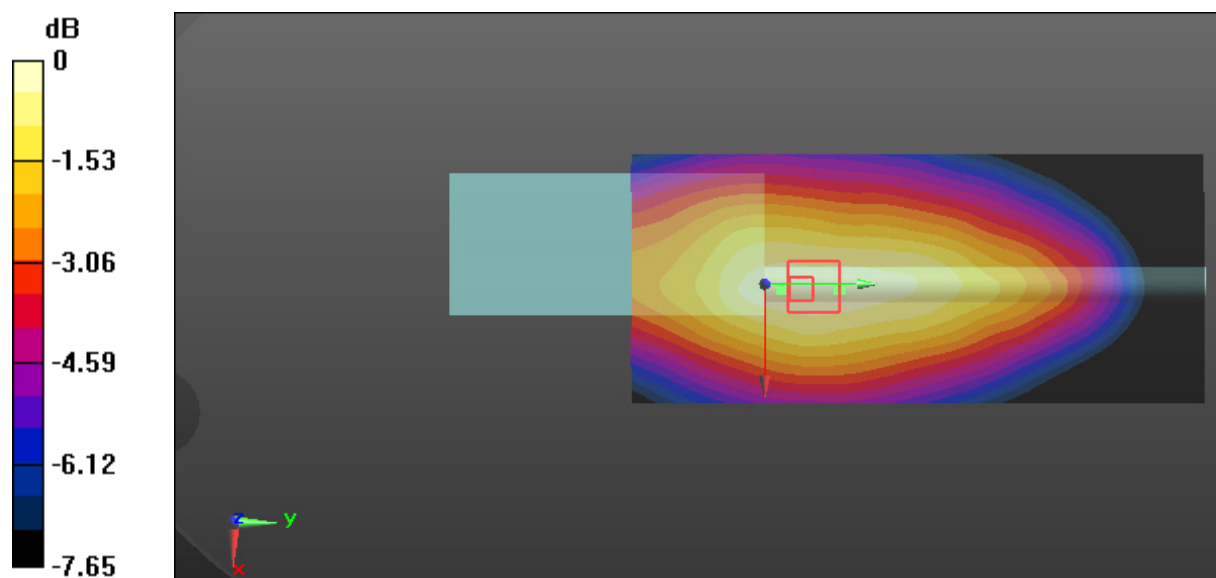

0 dB = 3.40 W/kg = 5.31 dBW/kg

Test Plot 2#: Ant 1(AF701)_PTT 4FSK_Face Up_136.0125 MHz_ PH790 VHF**DUT: DIGITAL PORTABLE RADIO; Type: PH790 VHF; Serial: 18080900821**

Communication System: 4FSK; Frequency: 136.012 MHz; Duty Cycle: 1:2

Medium parameters used: $f = 136.012$ MHz; $\sigma = 0.726$ S/m; $\epsilon_r = 52.929$; $\rho = 1000$ kg/m³

Phantom section: Flat Section

DASY5 Configuration:

- Probe: EX3DV4 - SN7329; ConvF(12.88, 12.88, 12.88); Calibrated: 2018/1/22;
- Sensor-Surface: 1.4mm (Mechanical Surface Detection)
- Electronics: DAE4 Sn1459; Calibrated: 2017/9/15
- Phantom: ELI v8.0; Type: QDOVA004AA; Serial: 2051
- Measurement SW: DASY52, Version 52.8 (8);

Area Scan (71x121x1): Interpolated grid: dx=1.500 mm, dy=1.500 mm

Maximum value of SAR (interpolated) = 1.40 W/kg

Zoom Scan (6x7x7)/Cube 0: Measurement grid: dx=8mm, dy=8mm, dz=5mm

Reference Value = 37.16 V/m; Power Drift = -0.19 dB

Peak SAR (extrapolated) = 1.71 W/kg

SAR(1 g) = 1.03 W/kg; SAR(10 g) = 0.767 W/kg

Maximum value of SAR (measured) = 1.40 W/kg

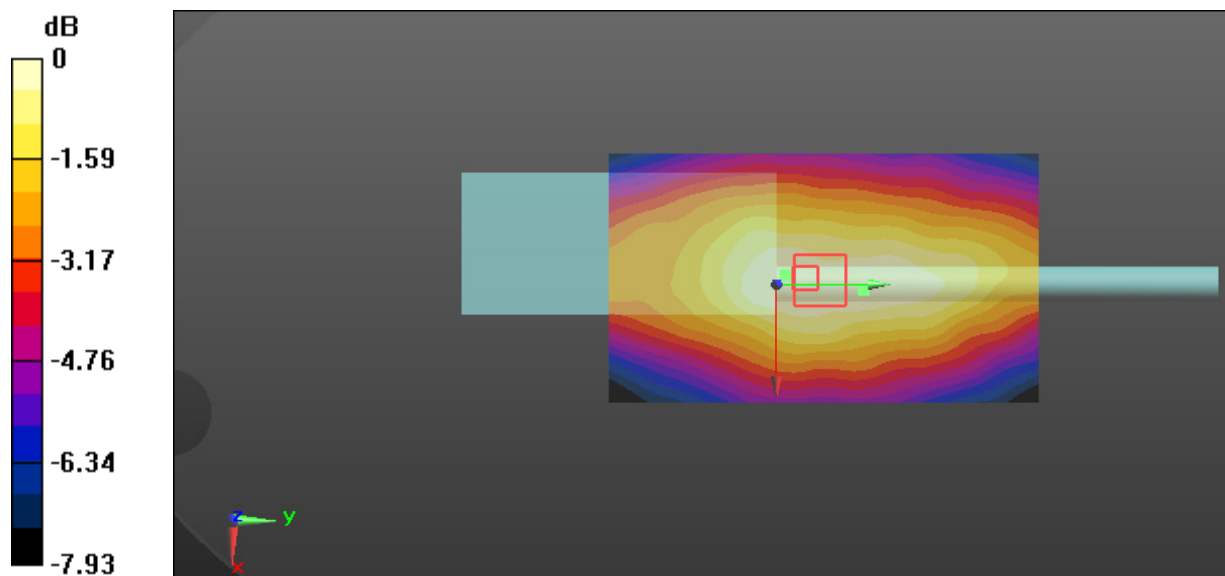

0 dB = 1.40 W/kg = 1.46 dBW/kg

Test Plot 3#: Ant 1(AF701)_PTT FM_Body Back_136.0125 MHz_ PH790 VHF

DUT: DIGITAL PORTABLE RADIO; Type: PH790 VHF; Serial: 18080900821

Communication System: FM; Frequency: 136.012 MHz; Duty Cycle: 1:1

Medium parameters used: $f = 136.012$ MHz; $\sigma = 0.791$ S/m; $\epsilon_r = 63.015$; $\rho = 1000$ kg/m³

Phantom section: Flat Section

DASY5 Configuration:

- Probe: EX3DV4 - SN7329; ConvF(12.56, 12.56, 12.56); Calibrated: 2018/1/22;
- Sensor-Surface: 1.4mm (Mechanical Surface Detection)
- Electronics: DAE4 Sn1459; Calibrated: 2017/9/15
- Phantom: ELI v8.0; Type: QDOVA004AA; Serial: 2051
- Measurement SW: DASY52, Version 52.8 (8);

Area Scan (61x161x1): Interpolated grid: dx=1.500 mm, dy=1.500 mm

Maximum value of SAR (interpolated) = 12.5 W/kg

Zoom Scan (5x5x7)/Cube 0: Measurement grid: dx=8mm, dy=8mm, dz=5mm

Reference Value = 91.21 V/m; Power Drift = -0.13 dB

Peak SAR (extrapolated) = 15.6 W/kg

SAR(1 g) = 7.02 W/kg; SAR(10 g) = 4.53 W/kg

Maximum value of SAR (measured) = 11.4 W/kg

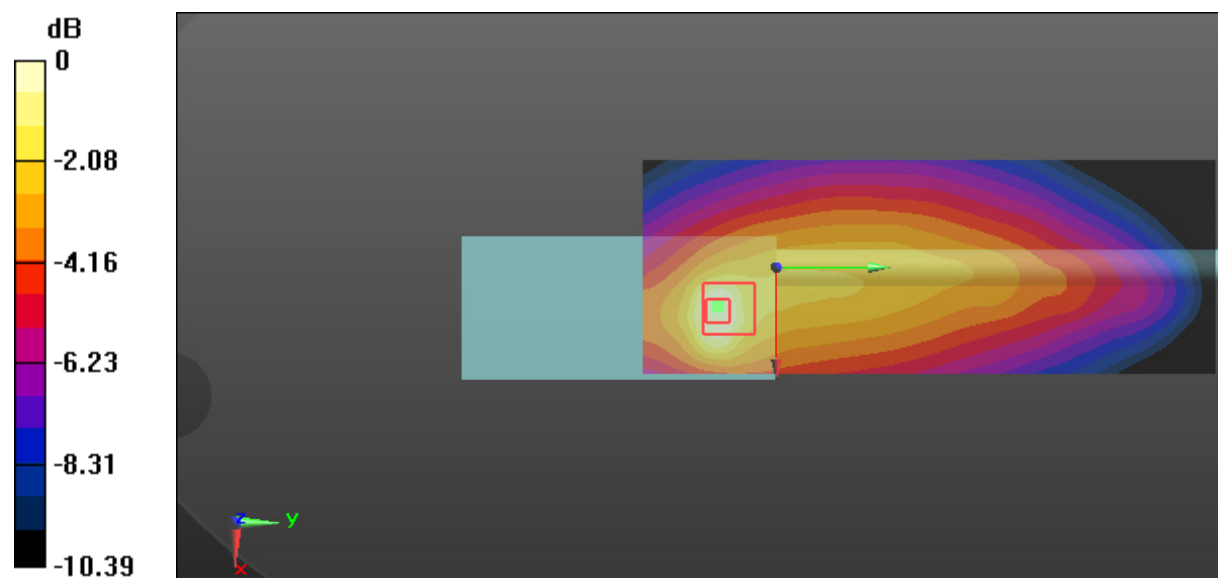

0 dB = 11.4 W/kg = 10.57 dBW/kg

Test Plot 4#: Ant 1(AF701)_PTT FM_Body Back_143 MHz_ PH790 VHF**DUT: DIGITAL PORTABLE RADIO; Type: PH790 VHF; Serial: 18080900821**

Communication System: FM; Frequency: 143 MHz; Duty Cycle: 1:1

Medium parameters used: $f = 143$ MHz; $\sigma = 0.796$ S/m; $\epsilon_r = 62.506$; $\rho = 1000$ kg/m³

Phantom section: Flat Section

DASY5 Configuration:

- Probe: EX3DV4 - SN7329; ConvF(12.56, 12.56, 12.56); Calibrated: 2018/1/22;
- Sensor-Surface: 1.4mm (Mechanical Surface Detection)
- Electronics: DAE4 Sn1459; Calibrated: 2017/9/15
- Phantom: ELI v8.0; Type: QDOVA004AA; Serial: 2051
- Measurement SW: DASY52, Version 52.8 (8);

Area Scan (61x161x1): Interpolated grid: dx=1.500 mm, dy=1.500 mm

Maximum value of SAR (interpolated) = 9.83 W/kg

Zoom Scan (6x5x7)/Cube 0: Measurement grid: dx=8mm, dy=8mm, dz=5mm

Reference Value = 82.54 V/m; Power Drift = -0.15 dB

Peak SAR (extrapolated) = 14.8 W/kg

SAR(1 g) = 5.67 W/kg; SAR(10 g) = 3.61 W/kg

Maximum value of SAR (measured) = 11.0 W/kg

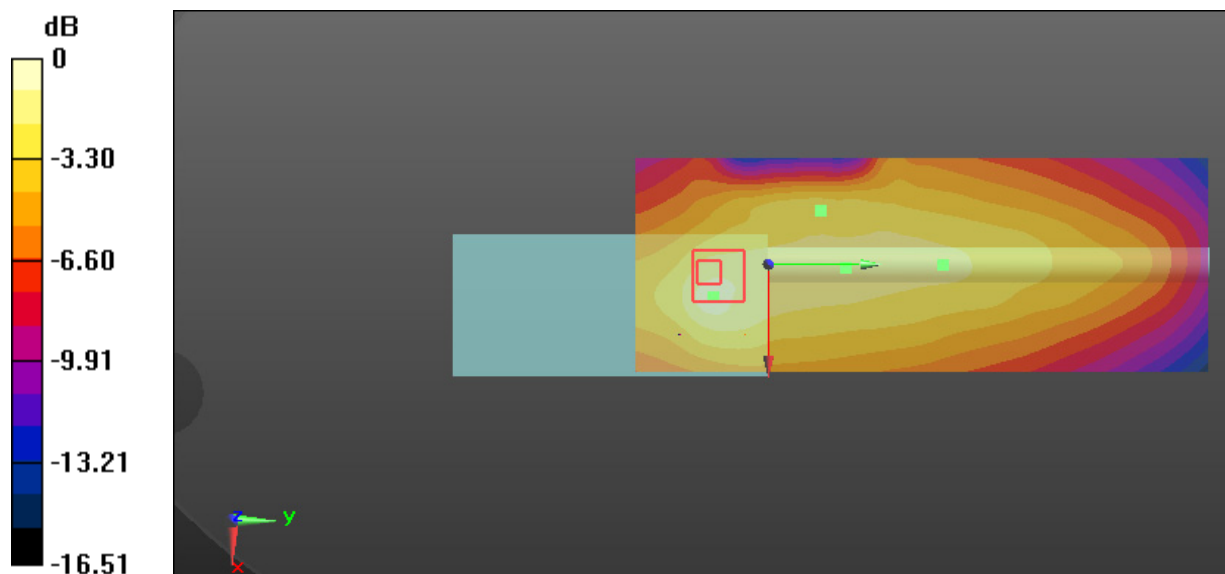

0 dB = 11.0 W/kg = 10.41 dBW/kg

Test Plot 5#: Ant 1(AF701)_PTT FM_Body Back_149.9875 MHz_ PH790 VHF**DUT: DIGITAL PORTABLE RADIO; Type: PH790 VHF; Serial: 18080900821**

Communication System: FM; Frequency: 149.988 MHz; Duty Cycle: 1:1

Medium parameters used: $f = 149.988$ MHz; $\sigma = 0.785$ S/m; $\epsilon_r = 61.679$; $\rho = 1000$ kg/m³

Phantom section: Flat Section

DASY5 Configuration:

- Probe: EX3DV4 - SN7329; ConvF(12.56, 12.56, 12.56); Calibrated: 2018/1/22;
- Sensor-Surface: 1.4mm (Mechanical Surface Detection)
- Electronics: DAE4 Sn1459; Calibrated: 2017/9/15
- Phantom: ELI v8.0; Type: QDOVA004AA; Serial: 2051
- Measurement SW: DASY52, Version 52.8 (8);

Area Scan (61x161x1): Interpolated grid: dx=1.500 mm, dy=1.500 mm

Maximum value of SAR (interpolated) = 6.62 W/kg

Zoom Scan (6x6x7)/Cube 0: Measurement grid: dx=8mm, dy=8mm, dz=5mm

Reference Value = 72.26 V/m; Power Drift = -0.10 dB

Peak SAR (extrapolated) = 8.86 W/kg

SAR(1 g) = 4.07 W/kg; SAR(10 g) = 2.73 W/kg

Maximum value of SAR (measured) = 6.39 W/kg

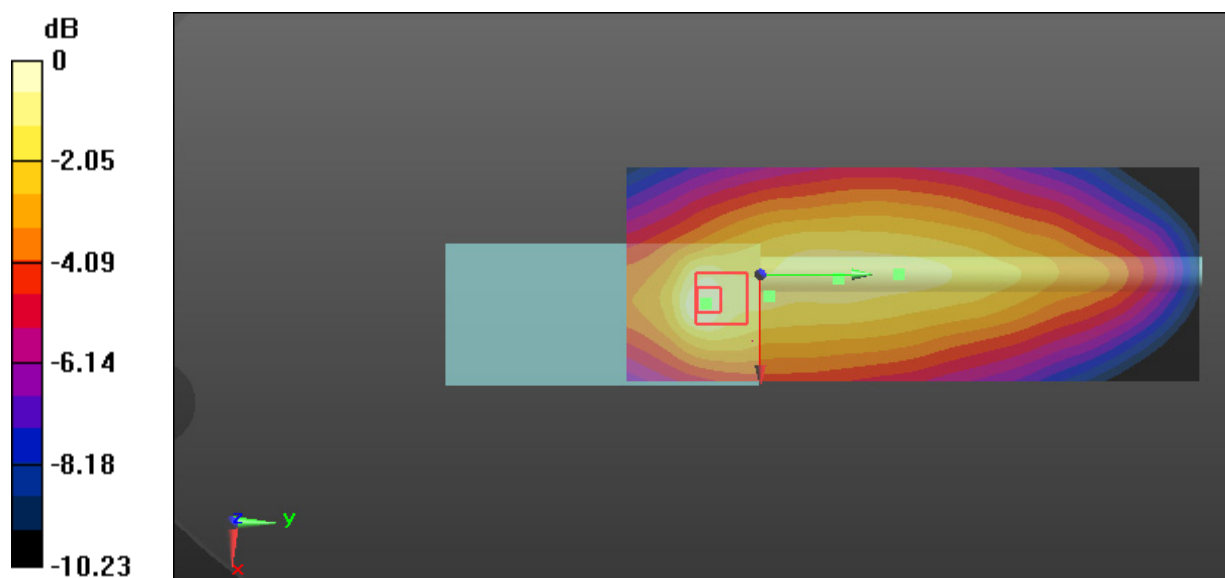

Test Plot 6#: Ant 1(AF701)_PTT 4FSK_Body Back_136.0125 MHz_ PH790 VHF

DUT: DIGITAL PORTABLE RADIO; Type: PH790 VHF; Serial: 18080900821

Communication System: 4FSK; Frequency: 136.012 MHz; Duty Cycle: 1:2

Medium parameters used: $f = 136.012 \text{ MHz}$; $\sigma = 0.791 \text{ S/m}$; $\epsilon_r = 63.015$; $\rho = 1000 \text{ kg/m}^3$

Phantom section: Flat Section

DASY5 Configuration:

- Probe: EX3DV4 - SN7329; ConvF(12.56, 12.56, 12.56); Calibrated: 2018/1/22;
- Sensor-Surface: 1.4mm (Mechanical Surface Detection)
- Electronics: DAE4 Sn1459; Calibrated: 2017/9/15
- Phantom: ELI v8.0; Type: QDOVA004AA; Serial: 2051
- Measurement SW: DASY52, Version 52.8 (8);

Area Scan (61x161x1): Interpolated grid: $dx=1.500 \text{ mm}$, $dy=1.500 \text{ mm}$

Maximum value of SAR (interpolated) = 5.31 W/kg

Zoom Scan (6x6x7)/Cube 0: Measurement grid: $dx=8\text{mm}$, $dy=8\text{mm}$, $dz=5\text{mm}$

Reference Value = 54.70 V/m; Power Drift = 0.04 dB

Peak SAR (extrapolated) = 9.08 W/kg

SAR(1 g) = 3.31 W/kg; SAR(10 g) = 2.03 W/kg

Maximum value of SAR (measured) = 5.84 W/kg

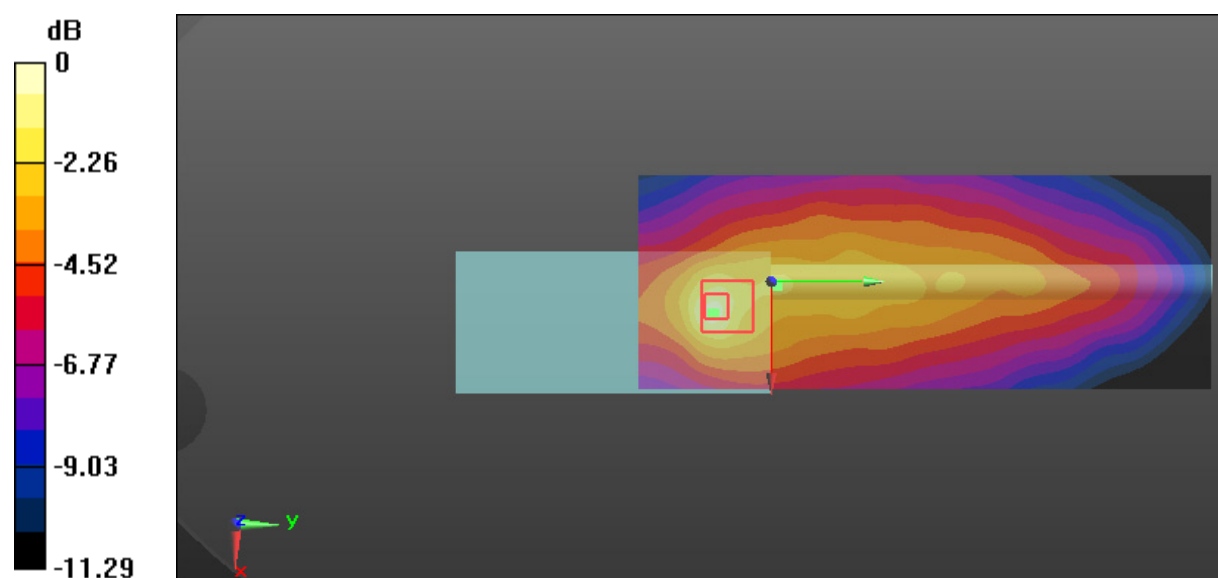

0 dB = 5.84 W/kg = 7.66 dBW/kg

Test Plot 7#: Ant 1(AF701)_PTT FM_Body Back_136.0125 MHz_ PH700 VHF

DUT: DIGITAL PORTABLE RADIO; Type: PH700 VHF; Serial: 18080900822

Communication System: FM; Frequency: 136.012 MHz; Duty Cycle: 1:1

Medium parameters used: $f = 136.012 \text{ MHz}$; $\sigma = 0.791 \text{ S/m}$; $\epsilon_r = 63.015$; $\rho = 1000 \text{ kg/m}^3$

Phantom section: Flat Section

DASY5 Configuration:

- Probe: EX3DV4 - SN7329; ConvF(12.56, 12.56, 12.56); Calibrated: 2018/1/22;
- Sensor-Surface: 1.4mm (Mechanical Surface Detection)
- Electronics: DAE4 Sn1459; Calibrated: 2017/9/15
- Phantom: ELI v8.0; Type: QDOVA004AA; Serial: 2051
- Measurement SW: DASY52, Version 52.8 (8);

Area Scan (61x161x1): Interpolated grid: $dx=1.500 \text{ mm}$, $dy=1.500 \text{ mm}$

Maximum value of SAR (interpolated) = 11.1 W/kg

Zoom Scan (6x6x7)/Cube 0: Measurement grid: $dx=8\text{mm}$, $dy=8\text{mm}$, $dz=5\text{mm}$

Reference Value = 81.58 V/m; Power Drift = -0.12 dB

Peak SAR (extrapolated) = 15.8 W/kg

SAR(1 g) = 6.74 W/kg; SAR(10 g) = 4.35 W/kg

Maximum value of SAR (measured) = 10.9 W/kg

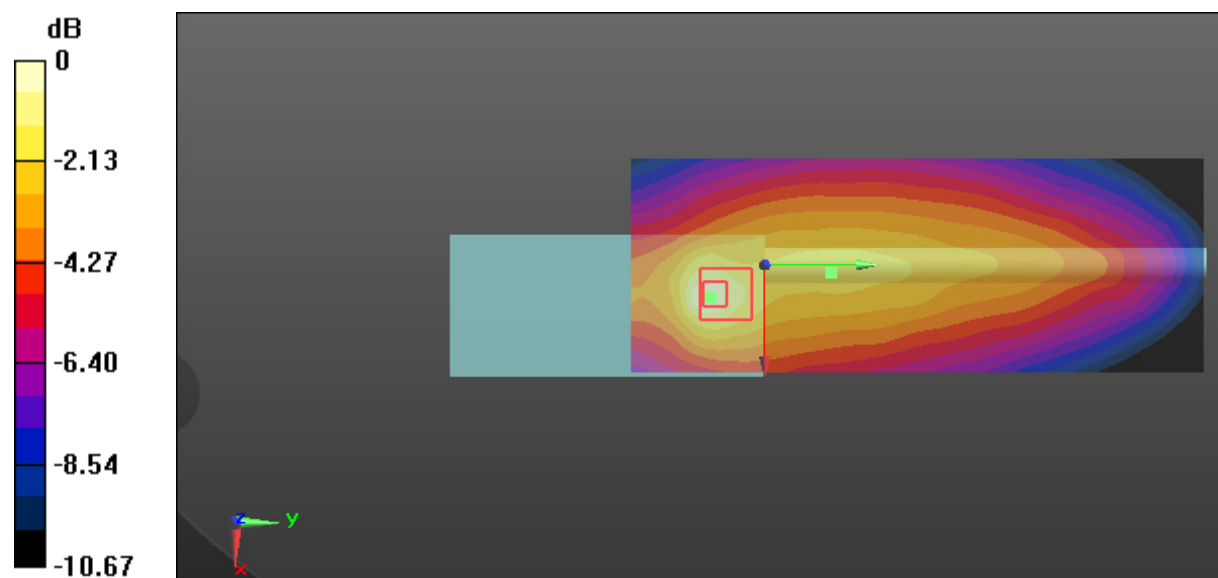

0 dB = 10.9 W/kg = 10.37 dBW/kg

Test Plot 8#: Ant 2(AF702)_PTT FM_Face Up_156 MHz_ PH790 VHF**DUT: DIGITAL PORTABLE RADIO; Type: PH790 VHF; Serial: 18080900821**

Communication System: FM; Frequency: 156 MHz; Duty Cycle: 1:1

Medium parameters used: $f = 156$ MHz; $\sigma = 0.754$ S/m; $\epsilon_r = 51.081$; $\rho = 1000$ kg/m³

Phantom section: Flat Section

DASY5 Configuration:

- Probe: EX3DV4 - SN7329; ConvF(12.88, 12.88, 12.88); Calibrated: 2018/1/22;
- Sensor-Surface: 1.4mm (Mechanical Surface Detection)
- Electronics: DAE4 Sn1459; Calibrated: 2017/9/15
- Phantom: ELI v8.0; Type: QDOVA004AA; Serial: 2051
- Measurement SW: DASY52, Version 52.8 (8);

Area Scan (61x161x1): Interpolated grid: dx=1.500 mm, dy=1.500 mm

Maximum value of SAR (interpolated) = 2.59 W/kg

Zoom Scan (6x6x7)/Cube 0: Measurement grid: dx=8mm, dy=8mm, dz=5mm

Reference Value = 98.04 V/m; Power Drift = -0.06 dB

Peak SAR (extrapolated) = 3.21 W/kg

SAR(1 g) = 2.04 W/kg; SAR(10 g) = 1.59 W/kg

Maximum value of SAR (measured) = 2.67 W/kg

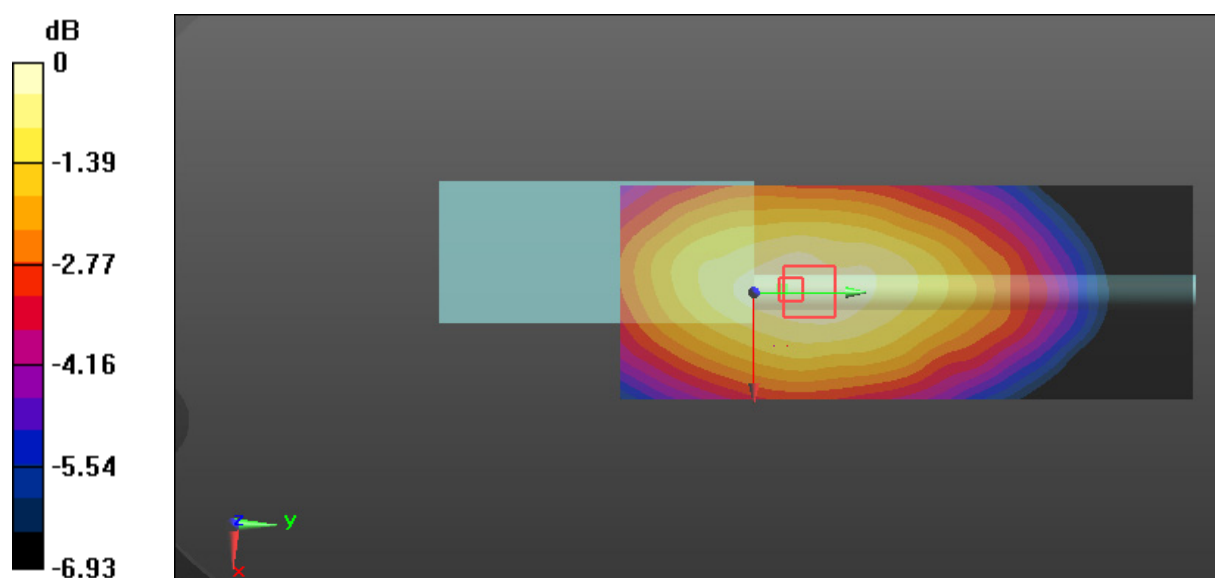

0 dB = 2.67 W/kg = 4.27 dBW/kg

Test Plot 9#: Ant 2(AF702)_PTT 4FSK_Face Up_156 MHz_PH790 VHF**DUT: DIGITAL PORTABLE RADIO; Type: PH790 VHF; Serial: 18080900821**

Communication System: 4FSK; Frequency: 156 MHz; Duty Cycle: 1:2

Medium parameters used: $f = 156$ MHz; $\sigma = 0.754$ S/m; $\epsilon_r = 51.081$; $\rho = 1000$ kg/m³

Phantom section: Flat Section

DASY5 Configuration:

- Probe: EX3DV4 - SN7329; ConvF(12.88, 12.88, 12.88); Calibrated: 2018/1/22;
- Sensor-Surface: 1.4mm (Mechanical Surface Detection)
- Electronics: DAE4 Sn1459; Calibrated: 2017/9/15
- Phantom: ELI v8.0; Type: QDOVA004AA; Serial: 2051
- Measurement SW: DASY52, Version 52.8 (8);

Area Scan (61x161x1): Interpolated grid: dx=1.500 mm, dy=1.500 mm

Maximum value of SAR (interpolated) = 1.35 W/kg

Zoom Scan (5x6x7)/Cube 0: Measurement grid: dx=8mm, dy=8mm, dz=5mm

Reference Value = 34.73 V/m; Power Drift = -0.12 dB

Peak SAR (extrapolated) = 1.58 W/kg

SAR(1 g) = 0.980 W/kg; SAR(10 g) = 0.747 W/kg

Maximum value of SAR (measured) = 1.28 W/kg

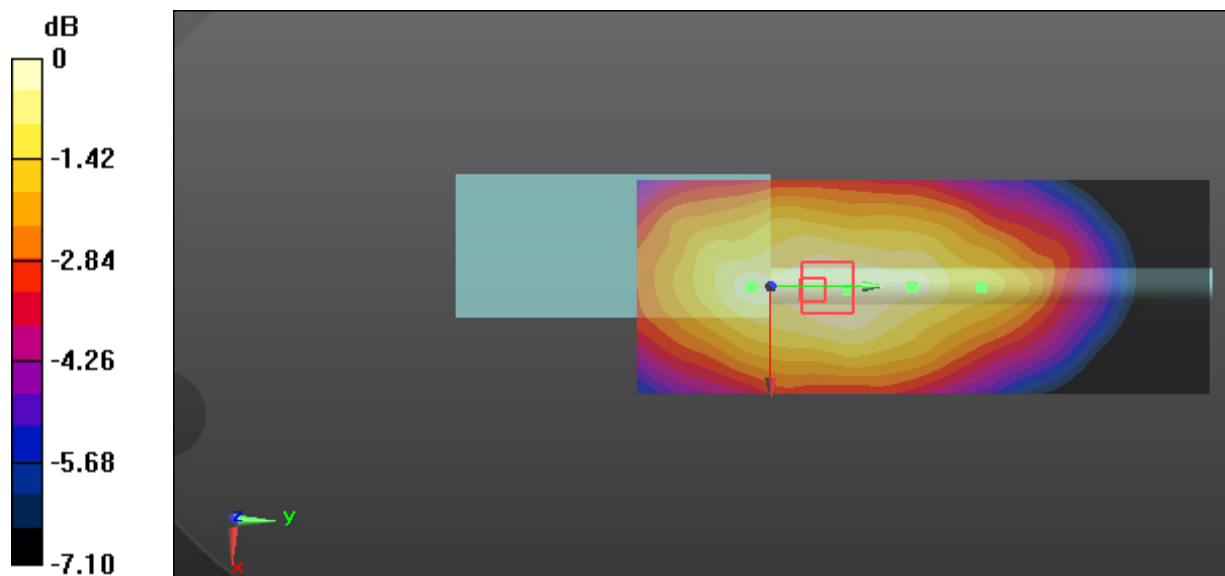

0 dB = 1.28 W/kg = 1.07 dBW/kg

Test Plot 10#: Ant 2(AF702)_PTT FM_Body Back_156 MHz_PH790 VHF**DUT: DIGITAL PORTABLE RADIO; Type: PH790 VHF; Serial: 18080900821**

Communication System: FM; Frequency: 156 MHz; Duty Cycle: 1:1

Medium parameters used: $f = 156$ MHz; $\sigma = 0.784$ S/m; $\epsilon_r = 61.29$; $\rho = 1000$ kg/m³

Phantom section: Flat Section

DASY5 Configuration:

- Probe: EX3DV4 - SN7329; ConvF(12.56, 12.56, 12.56); Calibrated: 2018/1/22;
- Sensor-Surface: 1.4mm (Mechanical Surface Detection)
- Electronics: DAE4 Sn1459; Calibrated: 2017/9/15
- Phantom: ELI v8.0; Type: QDOVA004AA; Serial: 2051
- Measurement SW: DASY52, Version 52.8 (8);

Area Scan (61x161x1): Interpolated grid: dx=1.500 mm, dy=1.500 mm

Maximum value of SAR (interpolated) = 8.60 W/kg

Zoom Scan (5x6x7)/Cube 0: Measurement grid: dx=8mm, dy=8mm, dz=5mm

Reference Value = 76.36 V/m; Power Drift = -0.14 dB

Peak SAR (extrapolated) = 10.4 W/kg

SAR(1 g) = 5.2 W/kg; SAR(10 g) = 3.57 W/kg

Maximum value of SAR (measured) = 7.79 W/kg

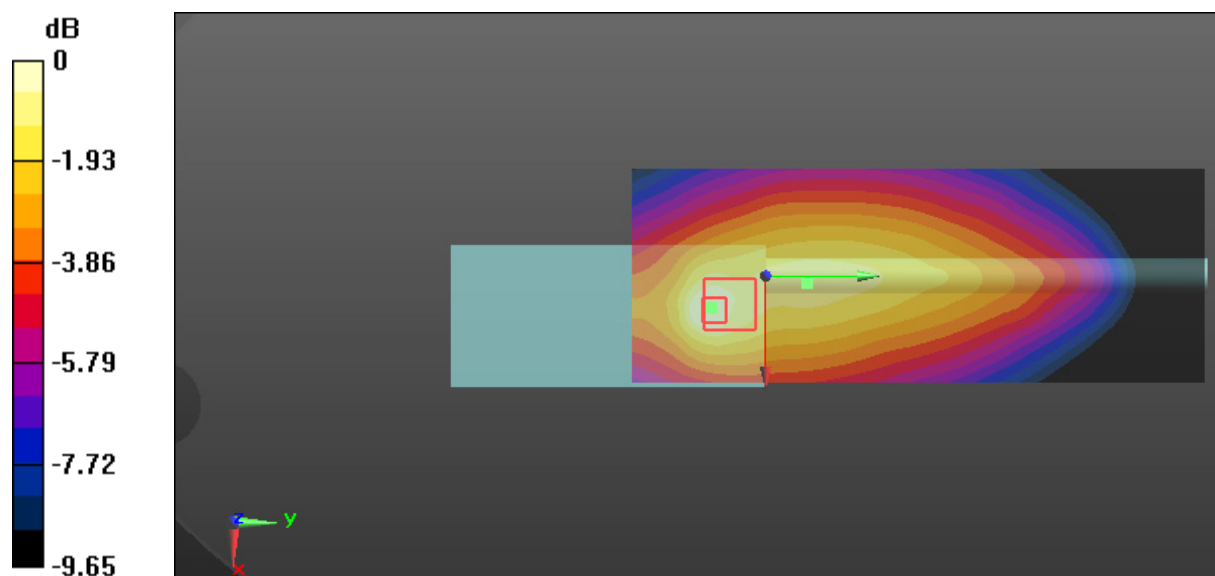

0 dB = 7.79 W/kg = 8.92 dBW/kg

Test Plot 11#: Ant 2(AF702)_PTT 4FSK_Body Back_156 MHz_PH790 VHF**DUT: DIGITAL PORTABLE RADIO; Type: PH790 VHF; Serial: 18080900821**

Communication System: 4FSK; Frequency: 156 MHz; Duty Cycle: 1:2

Medium parameters used: $f = 156$ MHz; $\sigma = 0.784$ S/m; $\epsilon_r = 61.29$; $\rho = 1000$ kg/m³

Phantom section: Flat Section

DASY5 Configuration:

- Probe: EX3DV4 - SN7329; ConvF(12.56, 12.56, 12.56); Calibrated: 2018/1/22;
- Sensor-Surface: 1.4mm (Mechanical Surface Detection)
- Electronics: DAE4 Sn1459; Calibrated: 2017/9/15
- Phantom: ELI v8.0; Type: QDOVA004AA; Serial: 2051
- Measurement SW: DASY52, Version 52.8 (8);

Area Scan (61x161x1): Interpolated grid: dx=1.500 mm, dy=1.500 mm

Maximum value of SAR (interpolated) = 3.59 W/kg

Zoom Scan (6x6x7)/Cube 0: Measurement grid: dx=8mm, dy=8mm, dz=5mm

Reference Value = 50.60 V/m; Power Drift = -0.17 dB

Peak SAR (extrapolated) = 4.86 W/kg

SAR(1 g) = 2.39 W/kg; SAR(10 g) = 1.63 W/kg

Maximum value of SAR (measured) = 3.61 W/kg

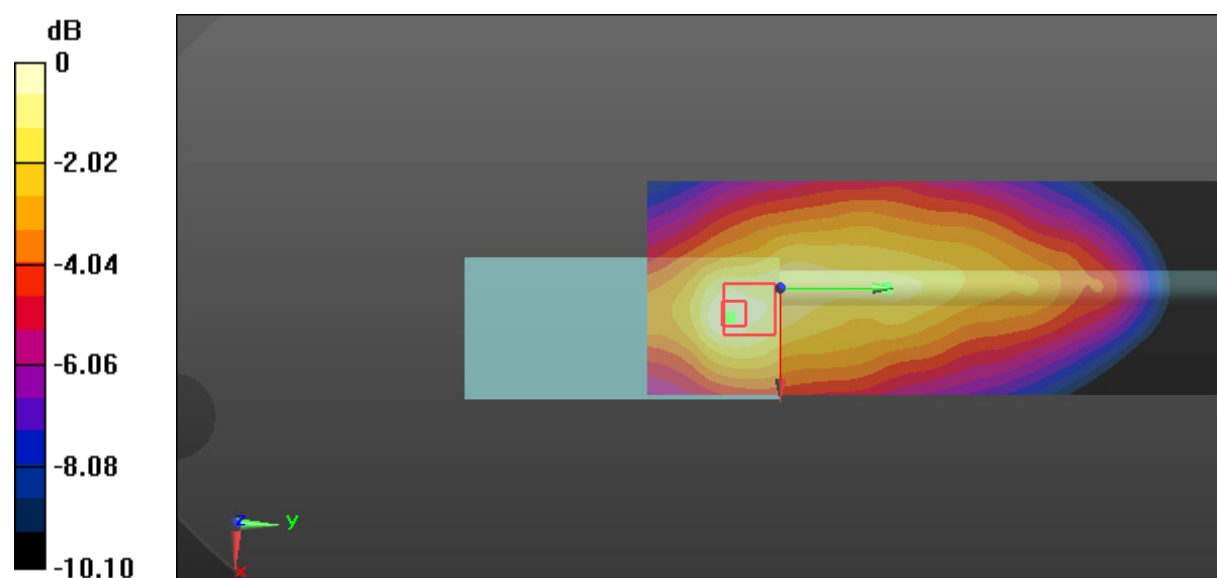

0 dB = 3.61 W/kg = 5.58 dBW/kg

Test Plot 12#: Ant 2(AF702)_PTT FM_Body Back_156 MHz_PH700 VHF**DUT: DIGITAL PORTABLE RADIO; Type: PH700 VHF; Serial: 18080900822**

Communication System: FM; Frequency: 156 MHz; Duty Cycle: 1:1

Medium parameters used: $f = 156$ MHz; $\sigma = 0.784$ S/m; $\epsilon_r = 61.29$; $\rho = 1000$ kg/m³

Phantom section: Flat Section

DASY5 Configuration:

- Probe: EX3DV4 - SN7329; ConvF(12.56, 12.56, 12.56); Calibrated: 2018/1/22;
- Sensor-Surface: 1.4mm (Mechanical Surface Detection)
- Electronics: DAE4 Sn1459; Calibrated: 2017/9/15
- Phantom: ELI v8.0; Type: QDOVA004AA; Serial: 2051
- Measurement SW: DASY52, Version 52.8 (8);

Area Scan (61x161x1): Interpolated grid: dx=1.500 mm, dy=1.500 mm

Maximum value of SAR (interpolated) = 5.80 W/kg

Zoom Scan (6x6x7)/Cube 0: Measurement grid: dx=8mm, dy=8mm, dz=5mm

Reference Value = 65.02 V/m; Power Drift = -0.11 dB

Peak SAR (extrapolated) = 9.37 W/kg

SAR(1 g) = 4.19 W/kg; SAR(10 g) = 2.8 W/kg

Maximum value of SAR (measured) = 6.77 W/kg

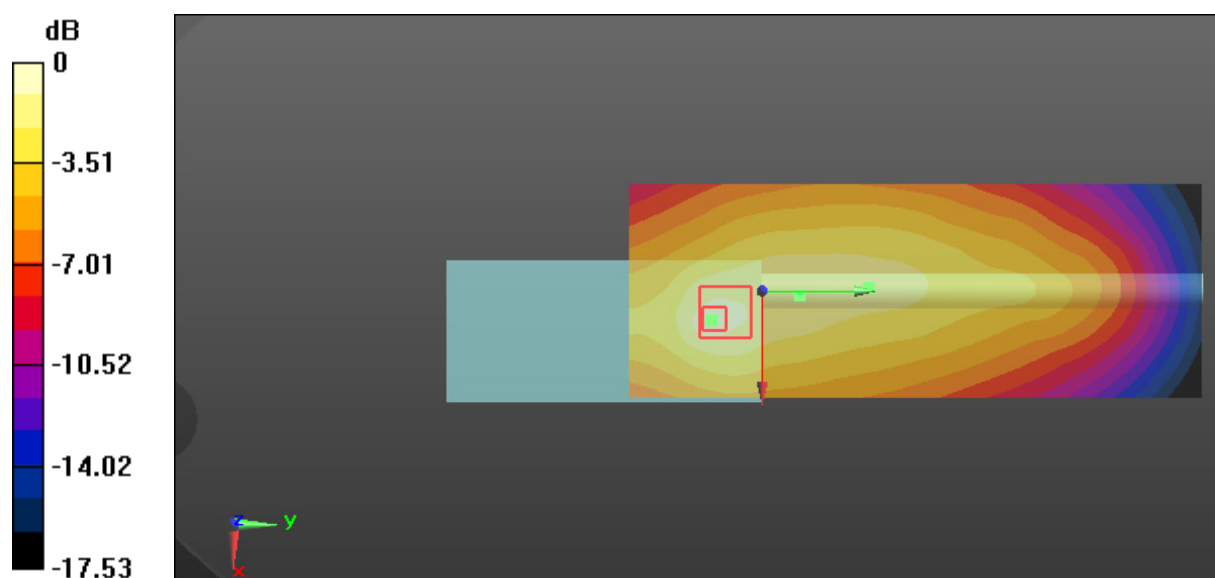

Test Plot 13#: Ant 3(AF703)_PTT FM_Face Up_162.0125 MHz_ PH790 VHF

DUT: DIGITAL PORTABLE RADIO; Type: PH790 VHF; Serial: 18080900821

Communication System: FM; Frequency: 162.012 MHz; Duty Cycle: 1:1

Medium parameters used: $f = 162.012$ MHz; $\sigma = 0.75$ S/m; $\epsilon_r = 51.587$; $\rho = 1000$ kg/m³

Phantom section: Flat Section

DASY5 Configuration:

- Probe: EX3DV4 - SN7329; ConvF(12.88, 12.88, 12.88); Calibrated: 2018/1/22;
- Sensor-Surface: 1.4mm (Mechanical Surface Detection)
- Electronics: DAE4 Sn1459; Calibrated: 2017/9/15
- Phantom: ELI v8.0; Type: QDOVA004AA; Serial: 2051
- Measurement SW: DASY52, Version 52.8 (8);

Area Scan (61x161x1): Interpolated grid: dx=1.500 mm, dy=1.500 mm

Maximum value of SAR (interpolated) = 3.04 W/kg

Zoom Scan (5x5x7)/Cube 0: Measurement grid: dx=8mm, dy=8mm, dz=5mm

Reference Value = 66.02 V/m; Power Drift = -0.04 dB

Peak SAR (extrapolated) = 3.63 W/kg

SAR(1 g) = 2.3 W/kg; SAR(10 g) = 1.78 W/kg

Maximum value of SAR (measured) = 3.01 W/kg

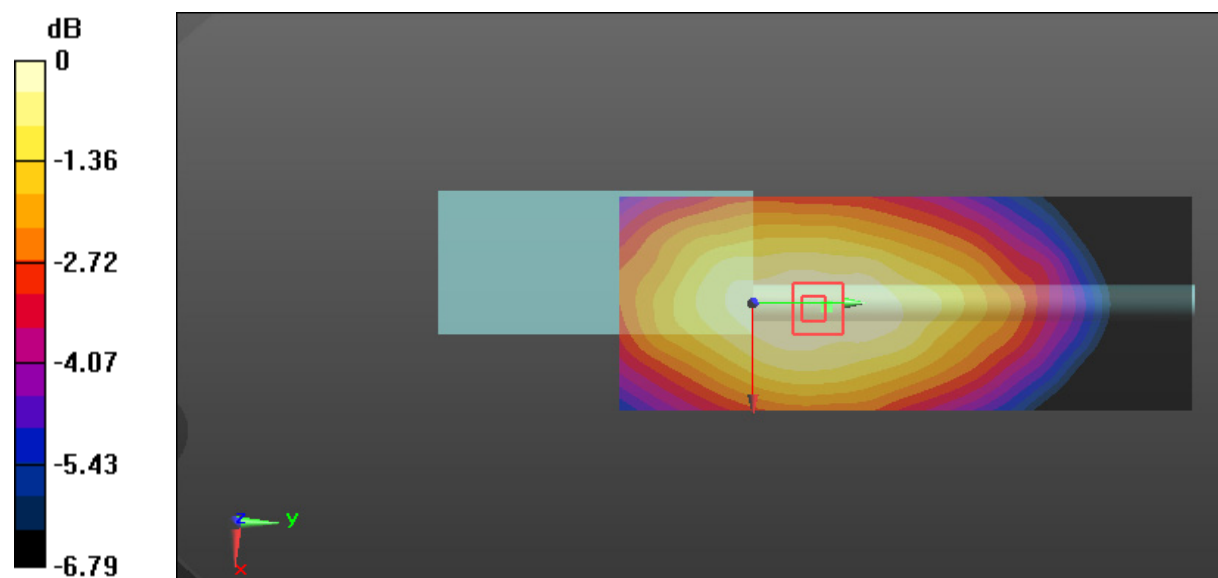

0 dB = 3.01 W/kg = 4.79 dBW/kg

Test Plot 14#: Ant 3(AF703)_PTT 4FSK_Face Up_162.0125 MHz_ PH790 VHF

DUT: DIGITAL PORTABLE RADIO; Type: PH790 VHF; Serial: 18080900821

Communication System: 4FSK; Frequency: 162.012 MHz; Duty Cycle: 1:2

Medium parameters used: $f = 162.012 \text{ MHz}$; $\sigma = 0.75 \text{ S/m}$; $\epsilon_r = 51.587$; $\rho = 1000 \text{ kg/m}^3$

Phantom section: Flat Section

DASY5 Configuration:

- Probe: EX3DV4 - SN7329; ConvF(12.88, 12.88, 12.88); Calibrated: 2018/1/22;
- Sensor-Surface: 1.4mm (Mechanical Surface Detection)
- Electronics: DAE4 Sn1459; Calibrated: 2017/9/15
- Phantom: ELI v8.0; Type: QDOVA004AA; Serial: 2051
- Measurement SW: DASY52, Version 52.8 (8);

Area Scan (61x161x1): Interpolated grid: $dx=1.500 \text{ mm}$, $dy=1.500 \text{ mm}$

Maximum value of SAR (interpolated) = 1.52 W/kg

Zoom Scan (6x6x7)/Cube 0: Measurement grid: $dx=8\text{mm}$, $dy=8\text{mm}$, $dz=5\text{mm}$

Reference Value = 36.42 V/m; Power Drift = 0.12 dB

Peak SAR (extrapolated) = 1.86 W/kg

SAR(1 g) = 1.15 W/kg; SAR(10 g) = 0.878 W/kg

Maximum value of SAR (measured) = 1.55 W/kg

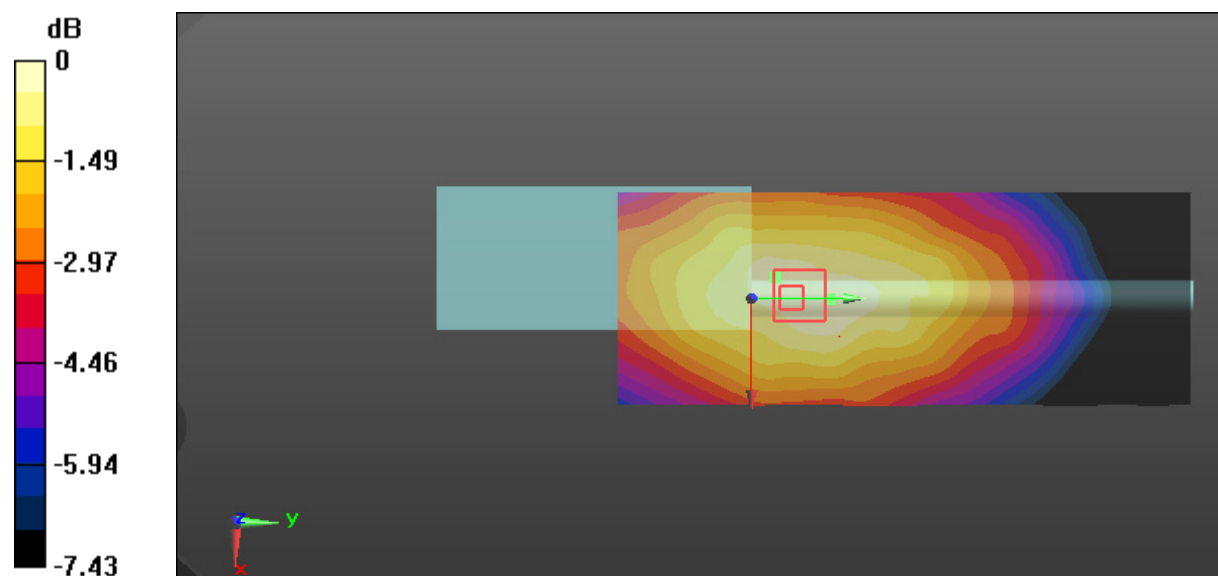

0 dB = 1.55 W/kg = 1.90 dBW/kg

Test Plot 15#: Ant 3(AF703)_PTT FM_Body Back_162.0125 MHz_PH790 VHF**DUT: DIGITAL PORTABLE RADIO; Type: PH790 VHF; Serial: 18080900821**

Communication System: FM; Frequency: 162.012 MHz; Duty Cycle: 1:1

Medium parameters used: $f = 162.012$ MHz; $\sigma = 0.777$ S/m; $\epsilon_r = 61.503$; $\rho = 1000$ kg/m³

Phantom section: Flat Section

DASY5 Configuration:

- Probe: EX3DV4 - SN7329; ConvF(12.56, 12.56, 12.56); Calibrated: 2018/1/22;
- Sensor-Surface: 1.4mm (Mechanical Surface Detection)
- Electronics: DAE4 Sn1459; Calibrated: 2017/9/15
- Phantom: ELI v8.0; Type: QDOVA004AA; Serial: 2051
- Measurement SW: DASY52, Version 52.8 (8);

Area Scan (61x161x1): Interpolated grid: dx=1.500 mm, dy=1.500 mm

Maximum value of SAR (interpolated) = 8.90 W/kg

Zoom Scan (6x6x7)/Cube 0: Measurement grid: dx=8mm, dy=8mm, dz=5mm

Reference Value = 73.00 V/m; Power Drift = -0.16 dB

Peak SAR (extrapolated) = 11.7 W/kg

SAR(1 g) = 5.26 W/kg; SAR(10 g) = 3.49 W/kg

Maximum value of SAR (measured) = 8.46 W/kg

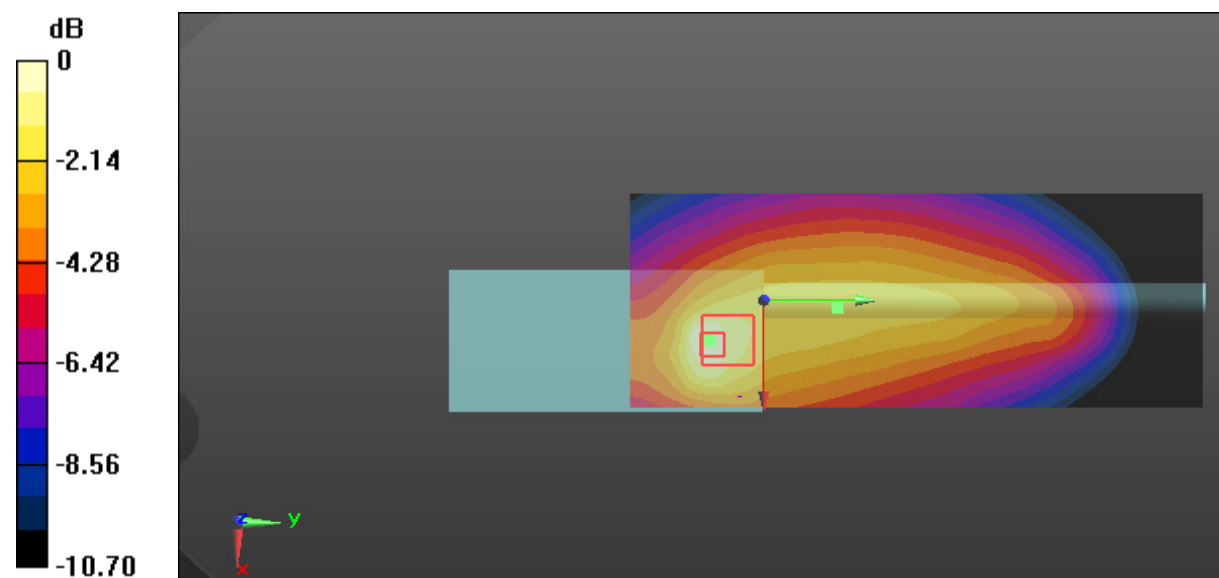

0 dB = 8.46 W/kg = 9.27 dBW/kg

Test Plot 16#: Ant 3(AF703)_PTT 4FSK_Body Back_162.0125 MHz_ PH790 VHF**DUT: DIGITAL PORTABLE RADIO; Type: PH790 VHF; Serial: 18080900821**

Communication System: 4FSK; Frequency: 162.012 MHz; Duty Cycle: 1:2

Medium parameters used: $f = 162.012$ MHz; $\sigma = 0.777$ S/m; $\epsilon_r = 61.503$; $\rho = 1000$ kg/m³

Phantom section: Flat Section

DASY5 Configuration:

- Probe: EX3DV4 - SN7329; ConvF(12.56, 12.56, 12.56); Calibrated: 2018/1/22;
- Sensor-Surface: 1.4mm (Mechanical Surface Detection)
- Electronics: DAE4 Sn1459; Calibrated: 2017/9/15
- Phantom: ELI v8.0; Type: QDOVA004AA; Serial: 2051
- Measurement SW: DASY52, Version 52.8 (8);

Area Scan (61x161x1): Interpolated grid: dx=1.500 mm, dy=1.500 mm

Maximum value of SAR (interpolated) = 3.99 W/kg

Zoom Scan (5x6x7)/Cube 0: Measurement grid: dx=8mm, dy=8mm, dz=5mm

Reference Value = 49.20 V/m; Power Drift = 0.14 dB

Peak SAR (extrapolated) = 6.00 W/kg

SAR(1 g) = 2.55 W/kg; SAR(10 g) = 1.68 W/kg

Maximum value of SAR (measured) = 4.19 W/kg

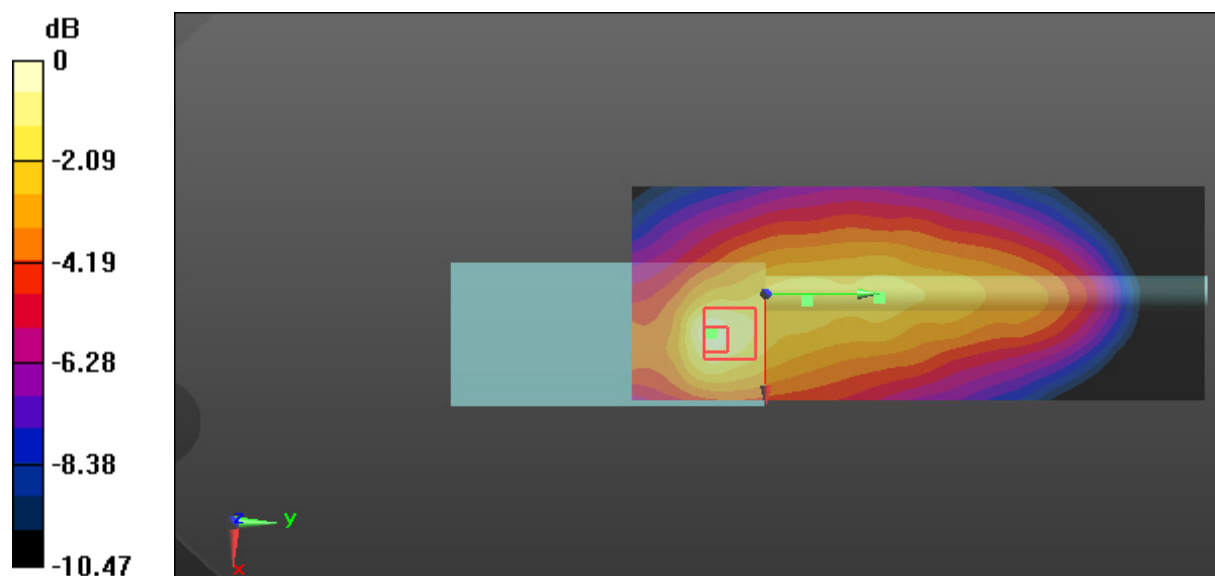

0 dB = 4.19 W/kg = 6.22 dBW/kg

Test Plot 17#: Ant 3(AF703)_PTT FM_Body Back_162.0125 MHz_ PH700 VHF

DUT: DIGITAL PORTABLE RADIO; Type: PH700 VHF; Serial: 18080900822

Communication System: FM; Frequency: 162.012 MHz; Duty Cycle: 1:1

Medium parameters used: $f = 162.012$ MHz; $\sigma = 0.777$ S/m; $\epsilon_r = 61.503$; $\rho = 1000$ kg/m³

Phantom section: Flat Section

DASY5 Configuration:

- Probe: EX3DV4 - SN7329; ConvF(12.56, 12.56, 12.56); Calibrated: 2018/1/22;
- Sensor-Surface: 1.4mm (Mechanical Surface Detection)
- Electronics: DAE4 Sn1459; Calibrated: 2017/9/15
- Phantom: ELI v8.0; Type: QDOVA004AA; Serial: 2051
- Measurement SW: DASY52, Version 52.8 (8);

Area Scan (61x161x1): Interpolated grid: dx=1.500 mm, dy=1.500 mm

Maximum value of SAR (interpolated) = 6.75 W/kg

Zoom Scan (5x6x7)/Cube 0: Measurement grid: dx=8mm, dy=8mm, dz=5mm

Reference Value = 69.38 V/m; Power Drift = -0.09 dB

Peak SAR (extrapolated) = 9.01 W/kg

SAR(1 g) = 4.28 W/kg; SAR(10 g) = 2.93 W/kg

Maximum value of SAR (measured) = 6.85 W/kg

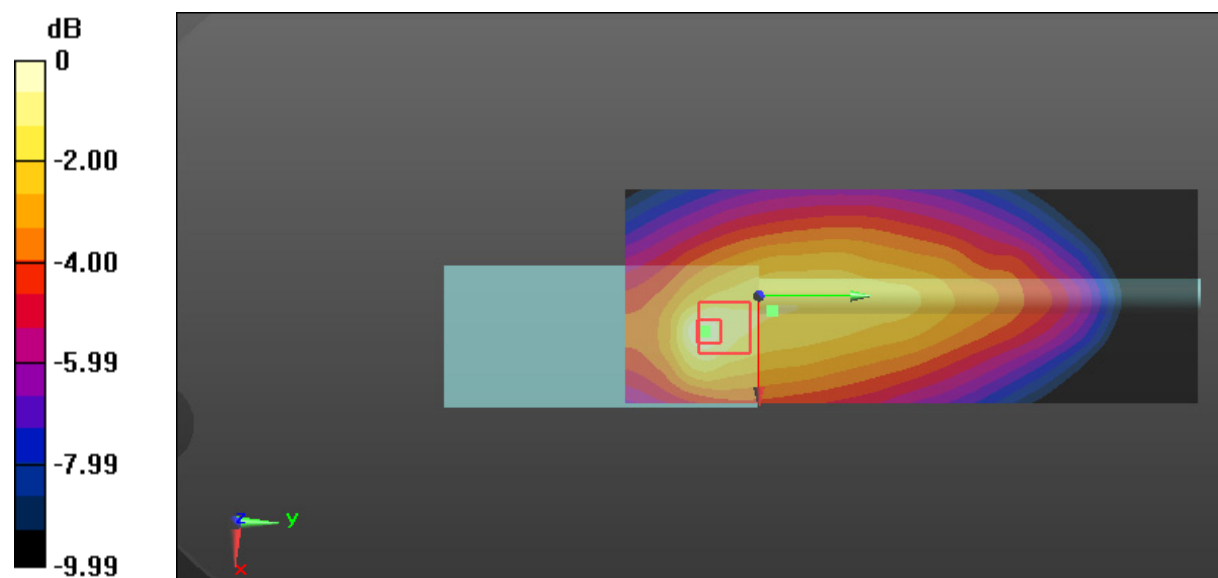

0 dB = 6.85 W/kg = 8.36 dBW/kg

Test Plot 18#: Ant 4(AF704)_PTT FM_Face Up_144.0125 MHz_ PH790 VHF

DUT: DIGITAL PORTABLE RADIO; Type: PH790 VHF; Serial: 18080900821

Communication System: FM; Frequency: 144.012 MHz; Duty Cycle: 1:1

Medium parameters used: $f = 144.012$ MHz; $\sigma = 0.742$ S/m; $\epsilon_r = 51.906$; $\rho = 1000$ kg/m³

Phantom section: Flat Section

DASY5 Configuration:

- Probe: EX3DV4 - SN7329; ConvF(12.88, 12.88, 12.88); Calibrated: 2018/1/22;
- Sensor-Surface: 1.4mm (Mechanical Surface Detection)
- Electronics: DAE4 Sn1459; Calibrated: 2017/9/15
- Phantom: ELI v8.0; Type: QDOVA004AA; Serial: 2051
- Measurement SW: DASY52, Version 52.8 (8);

Area Scan (61x161x1): Interpolated grid: dx=1.500 mm, dy=1.500 mm

Maximum value of SAR (interpolated) = 1.89 W/kg

Zoom Scan (6x6x7)/Cube 0: Measurement grid: dx=8mm, dy=8mm, dz=5mm

Reference Value = 42.30 V/m; Power Drift = -0.08 dB

Peak SAR (extrapolated) = 2.17 W/kg

SAR(1 g) = 1.4 W/kg; SAR(10 g) = 1.07 W/kg

Maximum value of SAR (measured) = 1.82 W/kg

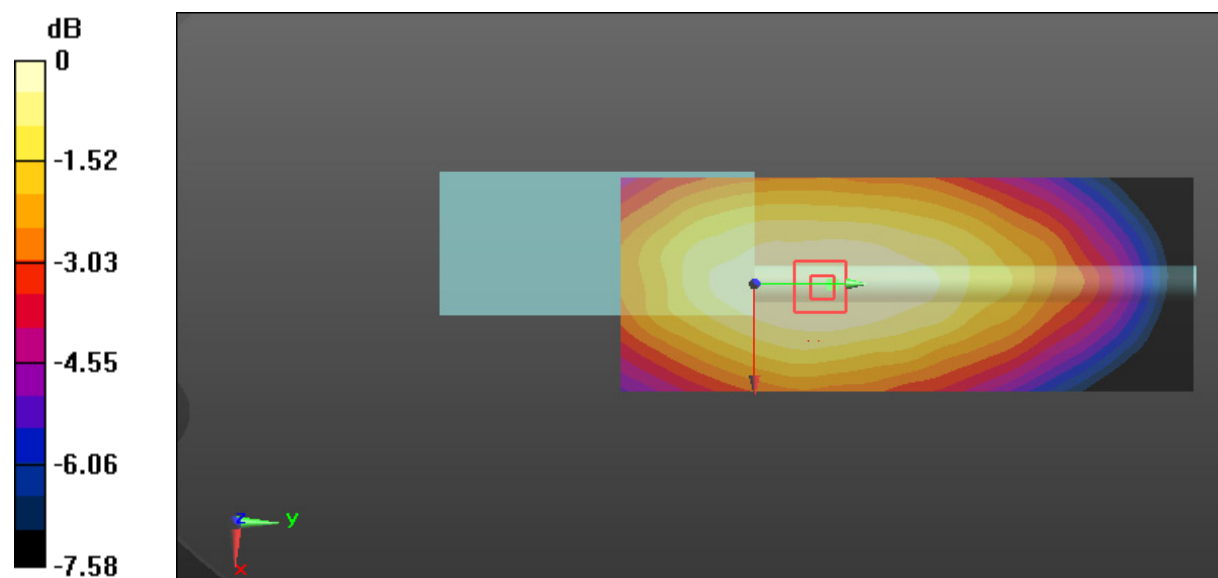

0 dB = 1.82 W/kg = 2.60 dBW/kg

Test Plot 19#: Ant 4(AF704)_PTT 4FSK_Face Up_144.0125 MHz_ PH790 VHF

DUT: DIGITAL PORTABLE RADIO; Type: PH790 VHF; Serial: 18080900821

Communication System: 4FSK; Frequency: 144.012 MHz; Duty Cycle: 1:2

Medium parameters used: $f = 144.012$ MHz; $\sigma = 0.742$ S/m; $\epsilon_r = 51.906$; $\rho = 1000$ kg/m³

Phantom section: Flat Section

DASY5 Configuration:

- Probe: EX3DV4 - SN7329; ConvF(12.88, 12.88, 12.88); Calibrated: 2018/1/22;
- Sensor-Surface: 1.4mm (Mechanical Surface Detection)
- Electronics: DAE4 Sn1459; Calibrated: 2017/9/15
- Phantom: ELI v8.0; Type: QDOVA004AA; Serial: 2051
- Measurement SW: DASY52, Version 52.8 (8);

Area Scan (61x161x1): Interpolated grid: dx=1.500 mm, dy=1.500 mm

Maximum value of SAR (interpolated) = 1.31 W/kg

Zoom Scan (6x7x7)/Cube 0: Measurement grid: dx=8mm, dy=8mm, dz=5mm

Reference Value = 36.04 V/m; Power Drift = -0.04 dB

Peak SAR (extrapolated) = 1.57 W/kg

SAR(1 g) = 1.01 W/kg; SAR(10 g) = 0.769 W/kg

Maximum value of SAR (measured) = 1.32 W/kg

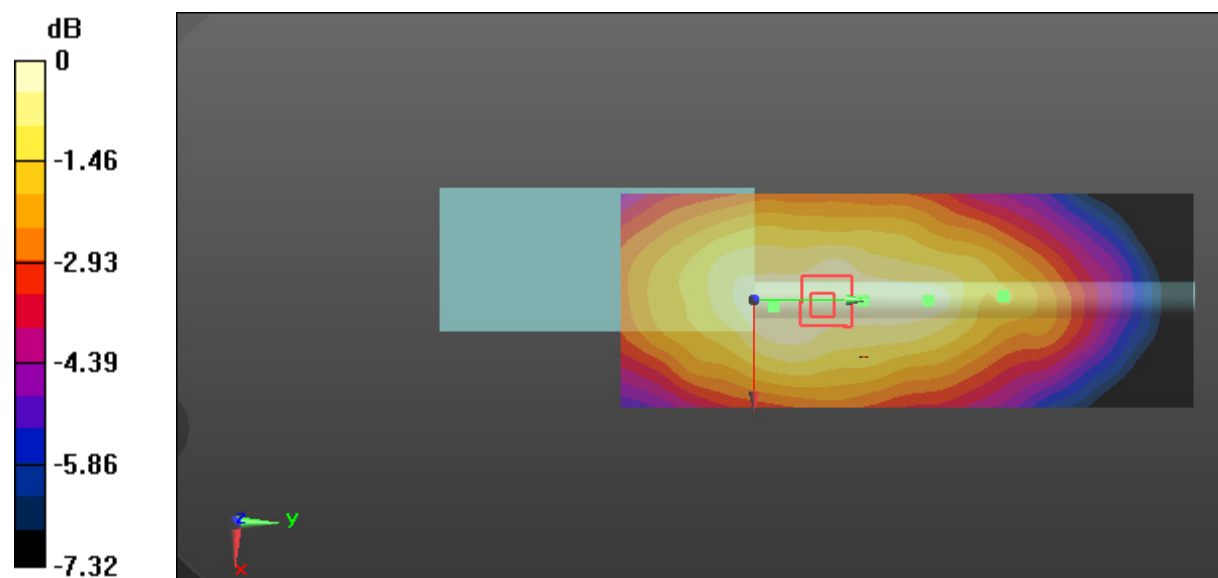

0 dB = 1.32 W/kg = 1.21 dBW/kg

Test Plot 20#: Ant 4(AF704)_PTT FM_Body Back_144.0125 MHz_PH790 VHF

DUT: DIGITAL PORTABLE RADIO; Type: PH790 VHF; Serial: 18080900821

Communication System: FM; Frequency: 144.012 MHz; Duty Cycle: 1:1

Medium parameters used: $f = 144.012$ MHz; $\sigma = 0.789$ S/m; $\epsilon_r = 62.609$; $\rho = 1000$ kg/m³

Phantom section: Flat Section

DASY5 Configuration:

- Probe: EX3DV4 - SN7329; ConvF(12.56, 12.56, 12.56); Calibrated: 2018/1/22;
- Sensor-Surface: 1.4mm (Mechanical Surface Detection)
- Electronics: DAE4 Sn1459; Calibrated: 2017/9/15
- Phantom: ELI v8.0; Type: QDOVA004AA; Serial: 2051
- Measurement SW: DASY52, Version 52.8 (8);

Area Scan (61x161x1): Interpolated grid: dx=1.500 mm, dy=1.500 mm

Maximum value of SAR (interpolated) = 8.35 W/kg

Zoom Scan (5x6x7)/Cube 0: Measurement grid: dx=8mm, dy=8mm, dz=5mm

Reference Value = 67.24 V/m; Power Drift = -0.19 dB

Peak SAR (extrapolated) = 12.5 W/kg

SAR(1 g) = 5.32 W/kg; SAR(10 g) = 3.38 W/kg

Maximum value of SAR (measured) = 8.88 W/kg

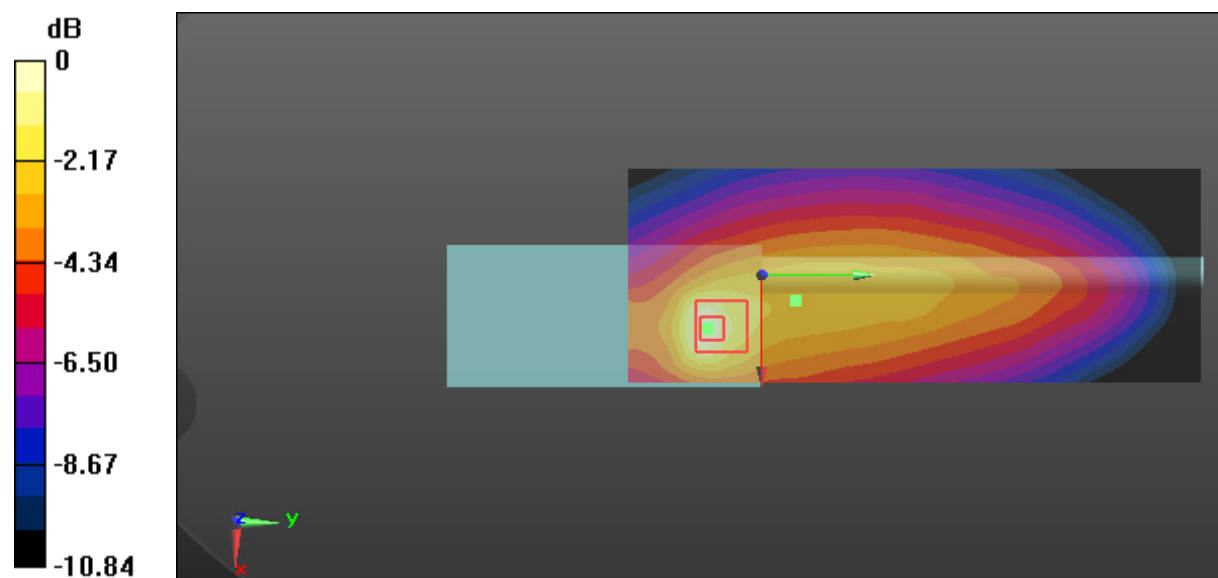

0 dB = 8.88 W/kg = 9.48 dBW/kg

Test Plot 21#: Ant 4(AF704)_PTT 4FSK_Body Back_144.0125 MHz_ PH790 VHF

DUT: DIGITAL PORTABLE RADIO; Type: PH790 VHF; Serial: 18080900821

Communication System: 4FSK; Frequency: 144.012 MHz; Duty Cycle: 1:2
 Medium parameters used: $f = 144.012 \text{ MHz}$; $\sigma = 0.789 \text{ S/m}$; $\epsilon_r = 62.609$; $\rho = 1000 \text{ kg/m}^3$
 Phantom section: Flat Section

DASY5 Configuration:

- Probe: EX3DV4 - SN7329; ConvF(12.56, 12.56, 12.56); Calibrated: 2018/1/22;
- Sensor-Surface: 1.4mm (Mechanical Surface Detection)
- Electronics: DAE4 Sn1459; Calibrated: 2017/9/15
- Phantom: ELI v8.0; Type: QDOVA004AA; Serial: 2051
- Measurement SW: DASY52, Version 52.8 (8);

Area Scan (61x161x1): Interpolated grid: $dx=1.500 \text{ mm}$, $dy=1.500 \text{ mm}$
 Maximum value of SAR (interpolated) = 4.00 W/kg

Zoom Scan (5x5x7)/Cube 0: Measurement grid: $dx=8\text{mm}$, $dy=8\text{mm}$, $dz=5\text{mm}$
 Reference Value = 49.93 V/m; Power Drift = -0.04 dB
 Peak SAR (extrapolated) = 6.14 W/kg
SAR(1 g) = 2.63 W/kg; SAR(10 g) = 1.7 W/kg
 Maximum value of SAR (measured) = 3.99 W/kg

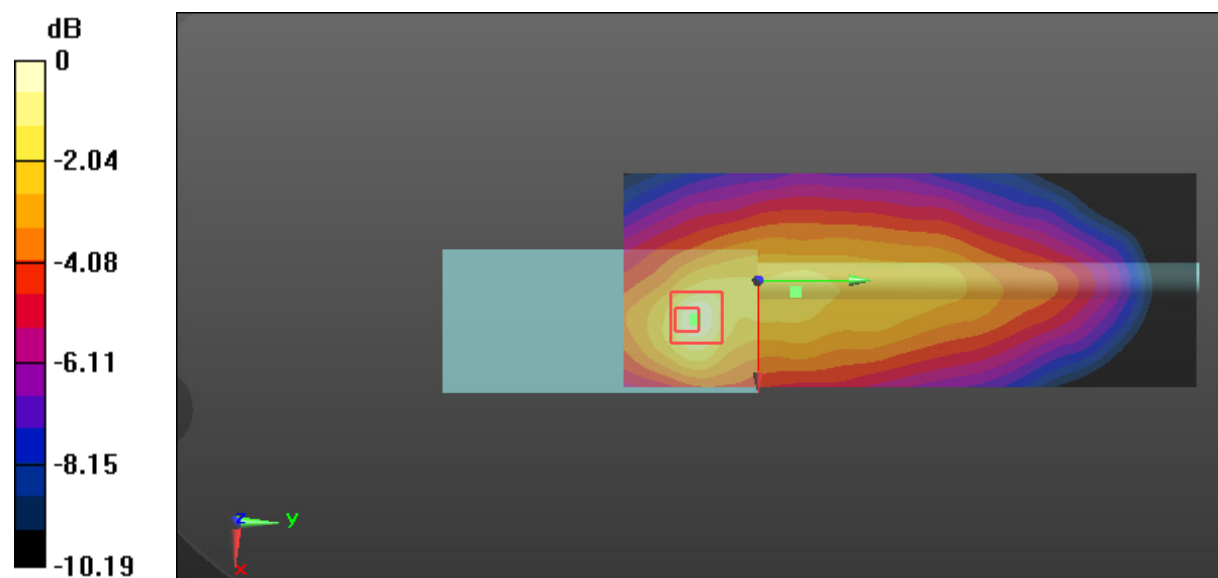

0 dB = 3.99 W/kg = 6.01 dBW/kg

Test Plot 22#: Ant 4(AF704)_PTT FM_Body Back_144.0125 MHz_ PH700 VHF**DUT: DIGITAL PORTABLE RADIO; Type: PH700 VHF; Serial: 18080900822**

Communication System: FM; Frequency: 144.012 MHz; Duty Cycle: 1:1

Medium parameters used: $f = 144.012$ MHz; $\sigma = 0.789$ S/m; $\epsilon_r = 62.609$; $\rho = 1000$ kg/m³

Phantom section: Flat Section

DASY5 Configuration:

- Probe: EX3DV4 - SN7329; ConvF(12.56, 12.56, 12.56); Calibrated: 2018/1/22;
- Sensor-Surface: 1.4mm (Mechanical Surface Detection)
- Electronics: DAE4 Sn1459; Calibrated: 2017/9/15
- Phantom: ELI v8.0; Type: QDOVA004AA; Serial: 2051
- Measurement SW: DASY52, Version 52.8 (8);

Area Scan (61x161x1): Interpolated grid: dx=1.500 mm, dy=1.500 mm

Maximum value of SAR (interpolated) = 8.00 W/kg

Zoom Scan (6x6x7)/Cube 0: Measurement grid: dx=8mm, dy=8mm, dz=5mm

Reference Value = 70.83 V/m; Power Drift = -0.19 dB

Peak SAR (extrapolated) = 10.5 W/kg

SAR(1 g) = 4.93 W/kg; SAR(10 g) = 3.27 W/kg

Maximum value of SAR (measured) = 7.86 W/kg

