

FCC Test Report

Product Name : Tire Pressure Monitoring System (TPMS)
Model No. : P12x
FCC ID. : 2AEJRP12X0

Applicant : Picolink Technology Co., Ltd.
Address : Rm.5, 8F, No.100, Sec.1, Jiafeng 11th Rd., Zhubei
City, Hsinchu County 302, Taiwan(R.O.C.)

Date of Receipt : 2015/04/23
Issued Date : 2015/05/18
Report No. : 1540501R-RFUSP14V00-A
Report Version : V1.0



The test results relate only to the samples tested.

The test report shall not be reproduced except in full without the written approval of QuieTek Corporation.

Test Report Certification

Issued Date : 2015/05/18

Report No. : 1540501R-RFUSP14V00-A



Product Name : Tire Pressure Monitoring System (TPMS)
 Applicant : Picolink Technology Co., Ltd.
 Address : Rm.5, 8F, No.100, Sec.1, Jiafeng 11th Rd., Zhubei City,
 Hsinchu County 302, Taiwan(R.O.C.)
 Manufacturer : Picolink Technology Co., Ltd.
 Model No. : P12x
 Trade Name : Picolink
 FCC ID. : 2AEJRP12X0
 EUT Voltage : DC 3V
 Applicable Standard : FCC 15 Subpart C Section 15.231(b): 2012
 Test Result : Complied

The test results relate only to the samples tested.

The test report shall not be reproduced except in full without the written approval of Quietek Corporation.

This report must not be used to claim product endorsement by NVLAP any agency of the U.S. Government

Documented By : Demi Chang

(Demi Chang / Engineering Adm. Specialist)

Reviewed By : Ken Huang

(Ken Huang / Engineer)

Approved By : Roy Wang

(Roy Wang / Director)

Laboratory Information

We, **Quietek Corporation**, are an independent RF consultancy that was established the whole facility in our laboratories. The test facility has been accredited/accepted (audited or listed) by the following related bodies in compliance with ISO 17025 specified testing scopes:

Taiwan R.O.C.	:	TAF, Accreditation Number: 3024 NCC, Certificate No : NCC-RCB-07
USA	:	FCC, Registration Number: 365520
Canada	:	IC, Submission No: 150981

The related certificate for our laboratories about the test site and management system can be downloaded from Quietek Corporation's Web Site:<http://www.quietek.com/chinese/about/certificates.aspx?bval=5>

The address and introduction of Quietek Corporation's laboratories can be founded in our Web site : <http://www.quietek.com/>

If you have any comments, Please don't hesitate to contact us. Our contact information is as below:

HsinChu Testing Laboratory:

No.75-2, 3rd Lin, Wangye Keng, Yonghxing Tsuen, Qionglin Shiang, Hsinchu County 307, Taiwan, R.O.C.
TEL:+886-3-592-8858 / FAX:+886-3-592-8859 E-Mail : service@quietek.com

Linkou Testing Laboratory:

No.5-22, Ruishukeng, Linkou Dist., New Taipei City 24451, Taiwan, R.O.C.
TEL : 886-2-8601-3788 / FAX : 886-2-8601-3789 E-Mail : service@quietek.com

TABLE OF CONTENTS

Description	Page
1. General Information.....	5
1.1. EUT Description.....	5
1.2. Test Mode.....	6
1.3. Tested System Details.....	7
1.4. Configuration of tested System.....	7
1.5. EUT Exercise Software.....	7
1.6. Test Facility.....	8
2. Radiated Emission.....	9
2.1. Test Equipment.....	9
2.2. Test Setup.....	10
2.3. Limits.....	11
2.4. Test Procedure.....	12
2.5. Test Specification.....	12
2.6. Uncertainty.....	12
2.7. Test Result.....	13
2.8. Test Photo.....	20
3. Occupied Bandwidth.....	22
3.1. Test Equipment.....	22
3.2. Test Setup.....	22
3.3. Limits.....	22
3.4. Test Specification.....	22
3.5. Uncertainty.....	22
3.6. Test Result.....	23
4. Duty cycle.....	24
4.1. Test Equipment.....	24
4.2. Test Setup.....	24
4.3. Limits.....	24
4.4. Test Specification.....	24
4.5. Uncertainty.....	24
4.6. Test Result.....	25
5. Transmitter time.....	26
5.1. Test Equipment.....	26
5.2. Test Setup.....	26
5.3. Limits.....	26
5.4. Test Specification.....	26
5.5. Uncertainty.....	26
5.6. Test Result.....	27
Attachment.....	28
EUT Photograph.....	29

1. General Information

1.1. EUT Description

Product Name	Tire Pressure Monitoring System (TPMS)
Model No.	P12x
Trade Name	Picolink
Frequency Range/Channel Number	433.92 MHz / 1 Channel
Antenna Gain	0dBi
Type of Modulation	FSK
Antenna Type	Soldered on PCB

Working Frequency of Each Channel	
Channel	Frequency
01	433.92MHz

Note:

1. This device is a Tire Pressure Monitoring System (TPMS) included a 433.92MHz transmitter and receiver function.
2. These tests are conducted on a sample for the purpose of demonstrating compliance with Part 15 Subpart C Paragraph 15.231.
3. The radiation measurements are performed in X, Y, Z axis positioning. Only the worst case is shown in the report.

1.2. Test Mode

QuieTek verified the construction and function in typical operation. All the test modes are performed in normal operation and are defined as:

Pre-Test Mode	
TX	Mode 1: Transmitter_Power by Battery (DC 3V)
Final Test Mode	
TX	Mode 1: Transmitter_Power by Battery (DC 3V)

Emission	
Performed Item	
Conducted Emission	No
Radiated Emission	Yes
Occupied Bandwidth	Yes
Duty cycle	Yes
Transmitter time	Yes

1.3. Tested System Details

The types for all equipments, plus descriptions of all cables used in the tested system (including inserted cards) are:

N/A

1.4. Configuration of tested System

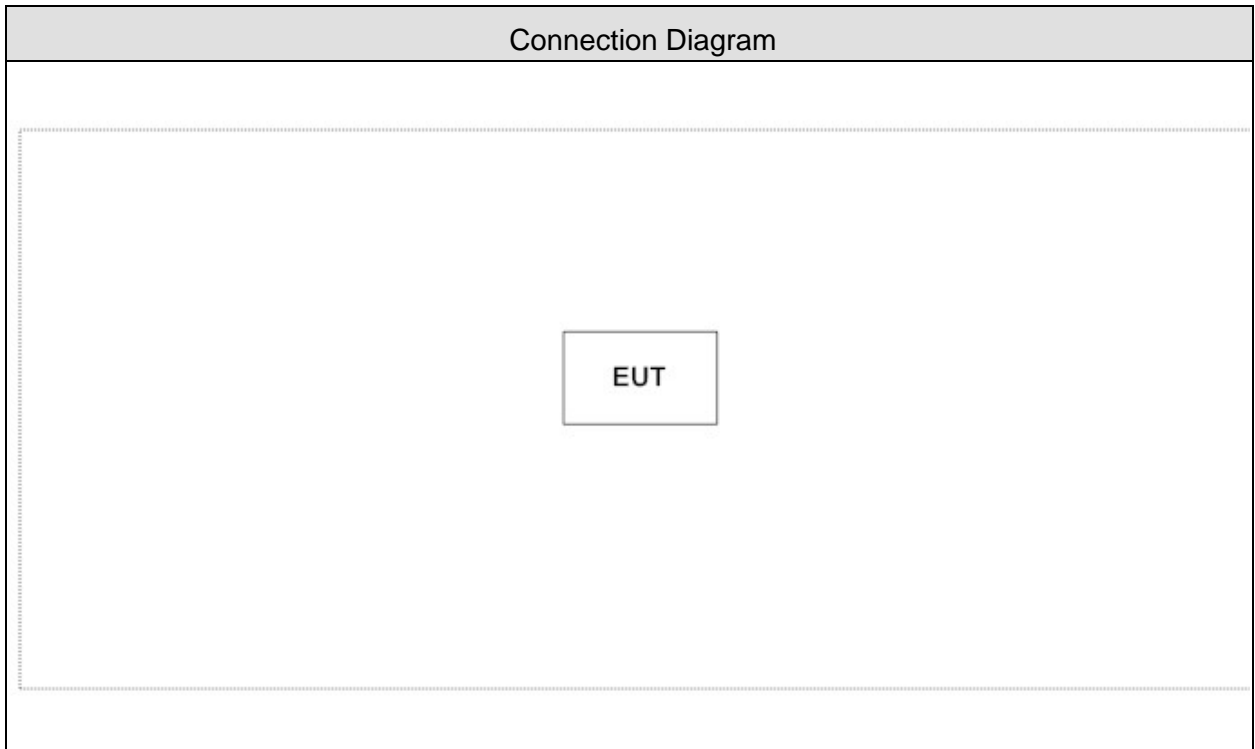

1.5. EUT Exercise Software

1	Setup the EUT as shown in section 1.4.
2	Turn on the EUT power.
3	The RF signal's status will continue transmit through EUT.
4	Repeat the above procedure.

1.6. Test Facility

Ambient conditions in the laboratory:

Items	Test Item	Required (IEC 68-1)	Actual
Temperature (°C)	FCC PART 15 C 15.231 Radiated Emission	15 - 35	25
Humidity (%RH)		25 - 75	50
Barometric pressure (mbar)		860 - 1060	950-1000
Temperature (°C)	FCC PART 15 C 15.231 Occupied Bandwidth	15 - 35	25
Humidity (%RH)		25 - 75	50
Barometric pressure (mbar)		860 - 1060	950-1000
Temperature (°C)	FCC PART 15 C 15.231 Duty Cycle	15 - 35	25
Humidity (%RH)		25 - 75	50
Barometric pressure (mbar)		860 - 1060	950-1000
Temperature (°C)	FCC PART 15 C 15.231 Transmitter Time	15 - 35	25
Humidity (%RH)		25 - 75	50
Barometric pressure (mbar)		860 - 1060	950-1000

2. Radiated Emission

2.1. Test Equipment

The following test equipments are used during the test:

Radiated Emission / CB1

Instrument	Manufacturer	Model No.	Serial No	Next Cal. Date
Bilog Antenna	SCHAFFNER	CBL6112B	2895(CB1)	2015/08/14
Double Ridged Guide				
Horn Antenna	Schwarzback	BBHA 9120	D743	2016/01/26
Pre-Amplifier	EMCI	EMC0031835	980233	2016/01/18
Pre-Amplifier	QuieTek	AP-025C	CHM-0706049	2016/01/18
Spectrum Analyzer	Agilent	E4440A	MY46187335	2016/01/07
k Type Cable	Huber Suhner	Sucoflex 102	25623/2	2016/01/26

Note: 1. All equipments that need to calibrate are with calibration period of 1 year.

2.2. Test Setup

Under 1GHz Test Setup:

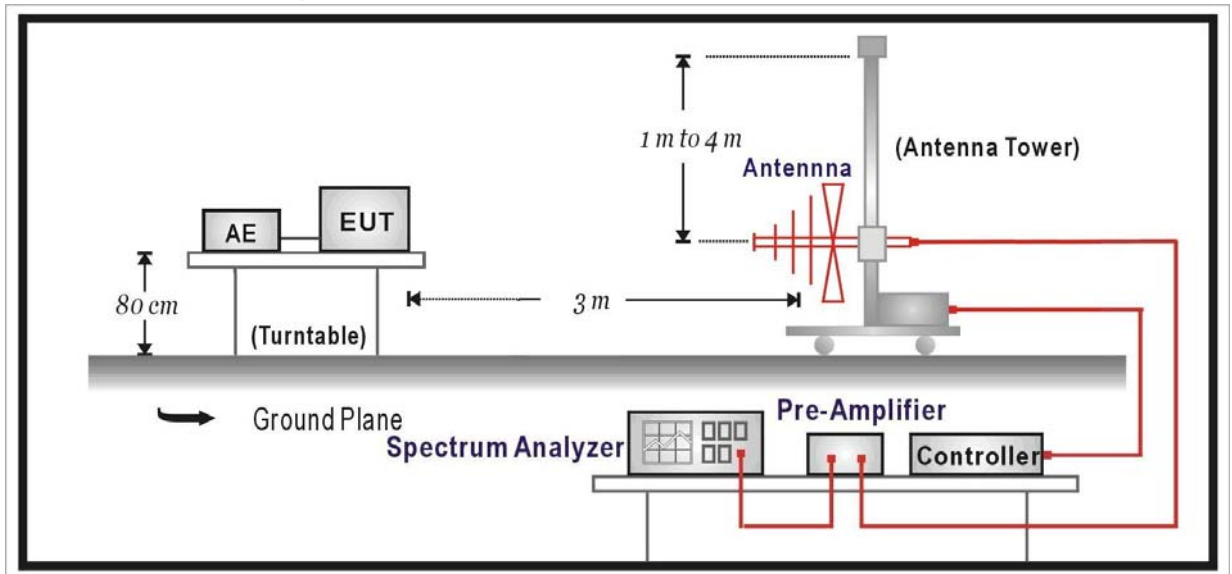

Above 1GHz Test Setup:

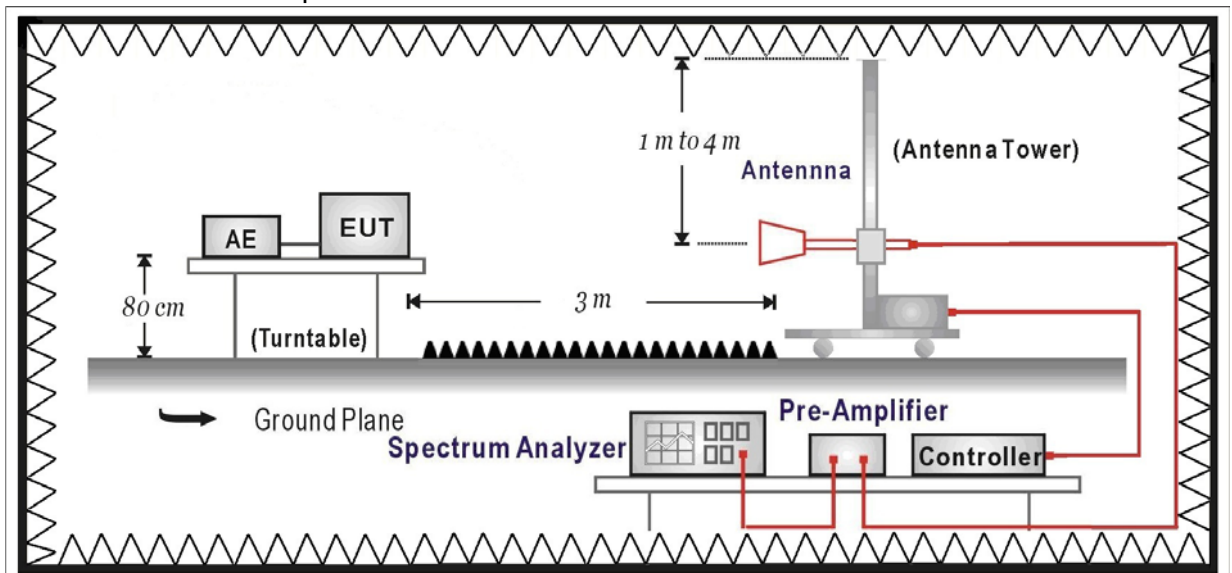

2.3. Limits

➤ Fundamental and Harmonics Emission Limits

FCC Part 15 Subpart C Paragraph 15.231(b) Limits				
Fundamental Frequency MHz	Field Strength of Fundamental		Field Strength of Harmonics	
	uV/m	dBuV/m	uV/m	dBuV/m
40.66-40.70	2250	67.04	225	47.04
70-130	1250	61.94	125	41.94
130-174	1250-3750	61.94-71.48	125-375	41.94-51.48
174-260	3750	71.48	375	51.48
260-470	3750-12500	71.48-81.94	375-1250	51.48-61.94
above 470	12500	81.94	1250	61.94

- Remarks: 1. RF Voltage (dBuV) = 20 log RF Voltage (uV)
 2. Distance refers to the distance in meters between the measuring instrument antenna and the closed point of any part of the device or system.
 3. The emission limit in this paragraph is based on measurement instrumentation employing an average detector.

➤ Spurious electric field strength limits

FCC Part 15 Subpart C Paragraph 15.209 Limits			
Frequency MHz	uV/m	dBuV/m	Measurement distance (meter)
0.009-0.490	2400/F(kHz)	See Remark ¹	300
0.490-1.705	24000/F(kHz)	See Remark ¹	30
1.705-30	30	29.5	30
30-88	100	40	3
88-216	150	43.5	3
216-960	200	46	3
Above 960	500	54	3

- Remarks : 1. RF Voltage (dBuV) = 20 log RF Voltage (uV)
 2. In the Above Table, the tighter limit applies at the band edges.
 3. Distance refers to the distance in meters between the measuring instrument antenna and the closed point of any part of the device or system.

2.4. Test Procedure

The EUT and its simulators are placed on a turn table which is 0.8 meter above ground. The turn table can rotate 360 degrees to determine the position of the maximum emission level. The EUT was positioned such that the distance from antenna to the EUT was 3 meters.

The antenna can move up and down between 1 meter and 4 meters to find out the maximum emission level.

Both horizontal and vertical polarizations of the antenna are set on measurement. In order to find the maximum emission, all of the interface cables must be manipulated according to ANSI C63.4: 2009 on radiated measurement.

The resolution bandwidth below 1GHz setting on the field strength meter is 120 kHz and above 1GHz is 1MHz.

Radiated emission measurements below 1GHz are made using broadband Bilog antenna and above 1GHz are made using Horn Antennas.

The measurement is divided into the Preliminary Measurement and the Final Measurement.

The suspected frequencies are searched for in Preliminary Measurement with the measurement antenna kept pointed at the source of the emission both in azimuth and elevation, with the polarization of the antenna oriented for maximum response. The antenna is pointed at an angle towards the source of the emission, and the EUT is rotated in both height and polarization to maximize the measured emission. The emission is kept within the illumination area of the 3 dB beamwidth of the antenna.

The worst radiated emission is measured on the Final Measurement.

The frequency range from 30MHz to 10th harmonics is checked.

2.5. Test Specification

According to FCC Part 15 Subpart C Paragraph 15.231(b): 2012

2.6. Uncertainty

± 3.8 dB below 1GHz

± 3.9 dB above 1GHz

2.7. Test Result

Product	Tire Pressure Monitoring System (TPMS)		
Test Item	Fundamental Radiated Emission		
Test Mode	Mode 1: Transmitter_Power by Battery (DC 3V)		
Date of Test	2015/05/06	Test Site	CB1

Frequency (MHz)	Correct Factor (dB)	Reading Level (dBuV)	Peak Measurement Level (dBuV/m)	Average Measurement Level (dBuV/m)	Average Limit (dBuV/m)
Horizontal					
433.920	15.843	25.921	41.763	21.763	80.830
Vertical					
433.920	15.843	46.679	62.521	42.521	80.830

Note1:

Peak Measurement Level = Reading Level + Correct Factor

Average Measurement Level = Peak Measurement Level + 20*Log (Duty Cycle)

Duty Cycle(Only Ton)= Ton/ Ton+off=(8.7ms/90.6ms)=0.096

20*Log(Duty Cycle) =-20.352

30MHz-1GHz Spurious :

Site : CB1	Time : 2015/05/06 - 23:04
Limit : FCC_CLASS_B_03M_QP	Margin : 6
Probe : CB1_FCC_EFS_30-1G-2_1011 - HORIZONTAL	Power : DC 3V
EUT : Tire Pressure Monitoring System (TPMS)	Note : 433MHz-Tx

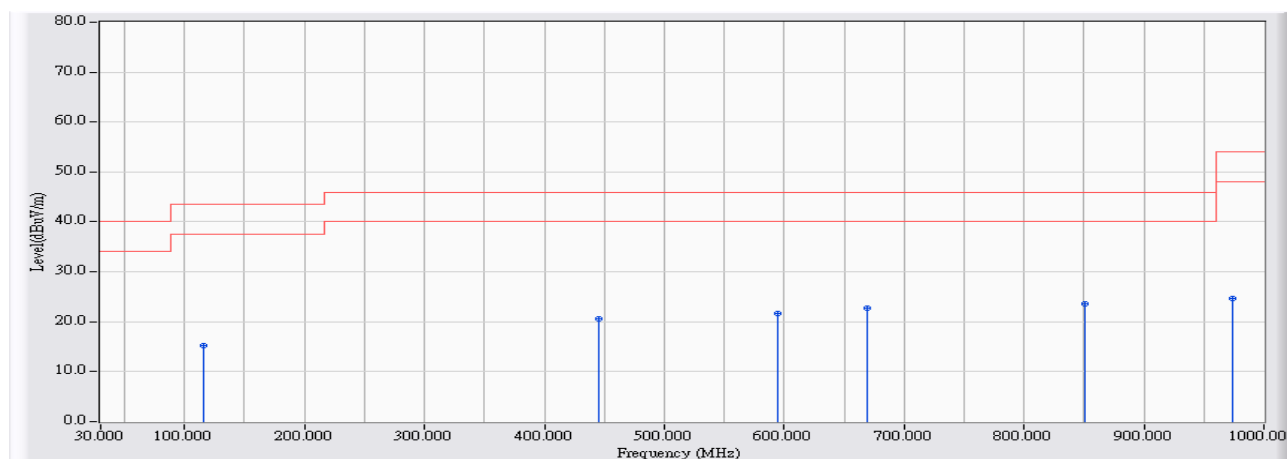

	Frequency (MHz)	Correct Factor (dB)	Reading Level (dBuV)	Measure Level (dBuV/m)	Margin (dB)	Limit (dBuV/m)	Detector Type
1	115.317	10.590	4.626	15.215	-28.285	43.500	QUASPEAK
2	445.922	16.086	4.564	20.650	-25.350	46.000	QUASPEAK
3	594.743	17.467	4.100	21.568	-24.432	46.000	QUASPEAK
4	668.911	17.834	5.006	22.840	-23.160	46.000	QUASPEAK
5	* 851.179	19.346	4.182	23.528	-22.472	46.000	QUASPEAK
6	973.823	20.075	4.496	24.571	-29.429	54.000	QUASPEAK

Note:

1. All Readings below 1GHz are QUASPEAK, above are performed with QUASPEAK measurements as necessary.
2. " * ", means this data is the worst emission level.
3. Measurement Level = Reading Level + Correct Factor.

Site : CB1	Time : 2015/05/06 - 23:06
Limit : FCC_CLASS_B_03M_QP	Margin : 6
Probe : CB1_FCC_EFS_30-1G-2_1011 - VERTICAL	Power : DC 3V
EUT : Tire Pressure Monitoring System (TPMS)	Note : 433MHz-Tx

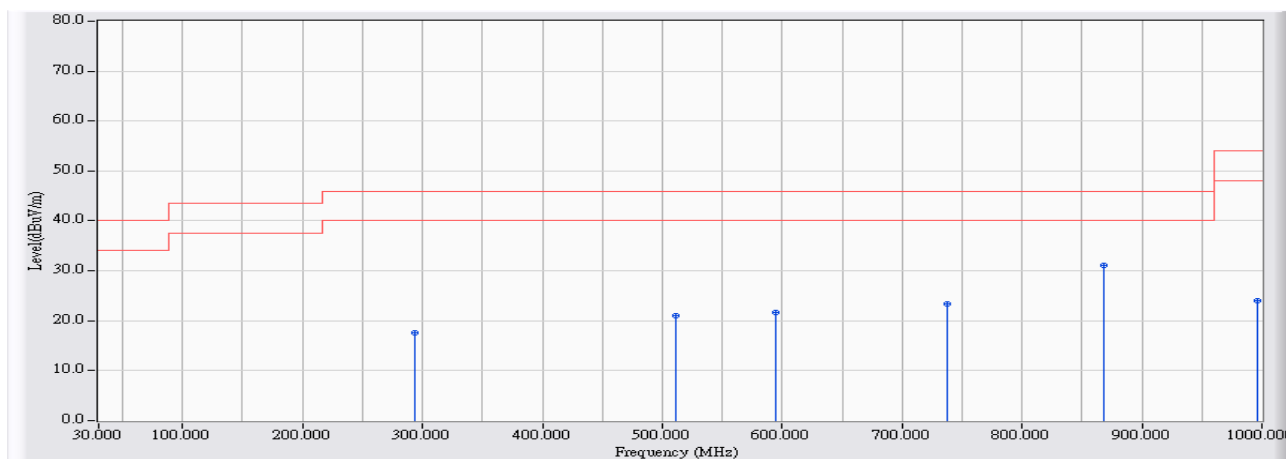

	Frequency (MHz)	Correct Factor (dB)	Reading Level (dBuV)	Measure Level (dBuV/m)	Margin (dB)	Limit (dBuV/m)	Detector Type
1	294.193	12.651	4.875	17.526	-28.474	46.000	QUASIPeAK
2	510.880	17.216	3.818	21.033	-24.967	46.000	QUASIPeAK
3	594.258	17.467	4.272	21.738	-24.262	46.000	QUASIPeAK
4	737.261	18.447	4.839	23.287	-22.713	46.000	QUASIPeAK
5	* 867.661	19.389	11.618	31.007	-14.993	46.000	QUASIPeAK
6	996.607	20.261	3.799	24.060	-29.940	54.000	QUASIPeAK

Note:

1. All Readings below 1GHz are QUASIPeAK, above are performed with QUASIPeAK measurements as necessary.
2. " * ", means this data is the worst emission level.
3. Measurement Level = Reading Level + Correct Factor.

Above 1GHz Spurious:

Site : CB1	Time : 2015/05/07 - 15:20
Limit : NCC_3.4.2_H_433.92MHz_03M_PK	Margin : 6
Probe : CB1_FCC_EFS_1-18G-1_0901 - HORIZONTAL	Power : DC 3V
EUT : Tire Pressure Monitoring System (TPMS)	Note : 433MHz-Tx

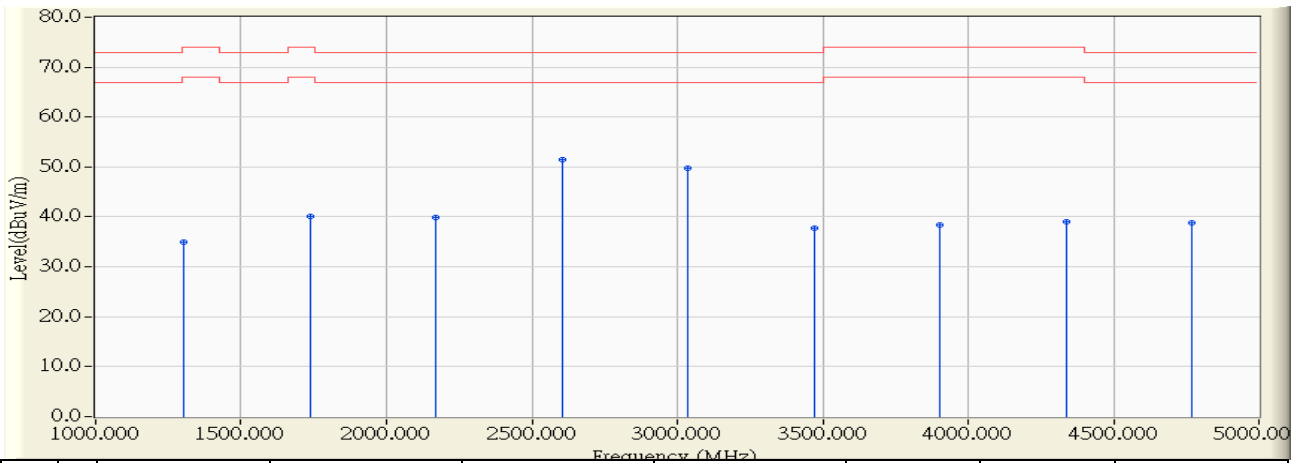

	Frequency (MHz)	Correct Factor (dB)	Reading Level (dBuV)	Measure Level (dBuV/m)	Margin (dB)	Limit (dBuV/m)	Detector Type
1	1301.230	-10.067	45.080	35.012	-38.988	74.000	PEAK
2	1736.000	-8.337	48.440	40.103	-33.897	74.000	PEAK
3	2170.140	-5.690	45.670	39.980	-32.890	72.870	PEAK
4	* 2603.940	-2.926	54.460	51.534	-21.336	72.870	PEAK
5	3036.880	-4.011	53.680	49.670	-23.200	72.870	PEAK
6	3470.710	-3.832	41.650	37.818	-35.052	72.870	PEAK
7	3904.630	-2.534	40.890	38.357	-35.643	74.000	PEAK
8	4340.020	-1.659	40.660	39.000	-35.000	74.000	PEAK
9	4767.200	-0.713	39.550	38.836	-34.034	72.870	PEAK

Note:

1. All Readings below 1GHz are Quasi-Peak, above are performed with peak and/or average measurements as necessary.
2. " * ", means this data is the worst emission level.
3. Measurement Level = Reading Level + Correct Factor.
4. The average measurement was not performed when the peak measured data under the limit of average detection. If the readings given are average, peak measurement should also be supplied.

Site : CB1	Time : 2015/05/07 – 16:30
Limit : NCC_3.4.2_H_433.92MHz_03M_AV	Margin : 6
Probe : CB1_FCC_EFS_1-18G-1_0901 - HORIZONTAL	Power : DC 3V
EUT : Tire Pressure Monitoring System (TPMS)	Note : 433MHz-Tx

		Frequency (MHz)	Peak Measurement (dBuV/m)	Duty Cycle Factor (dB)	Measurement Level (dBuV/m)	Margin (dB)	Limit (dBuV/m)	Detector Type
1		2603.940	-2.926	54.460	51.534	31.182	52.870	Average
2	*	3036.880	-4.011	53.680	49.670	29.318	52.870	Average

Note:

Peak Measure Value=Reading Value + Correct Factor

Average Measure Value=Peak Measure Value+20*LOG(Duty Cycle)

Duty Cycle=(Ton/(Ton+Toff))=8.7/90.6=0.096

20*LOG(Duty Cycle)=-20.352

Site : CB1	Time : 2015/05/07 - 16:00
Limit : NCC_3.4.2_H_433.92MHz_03M_PK	Margin : 6
Probe : CB1_FCC_EFS_1-18G_H2 - VERTICAL	Power : DC 3V
EUT : Tire Pressure Monitoring System (TPMS)	Note : 433MHz-Tx

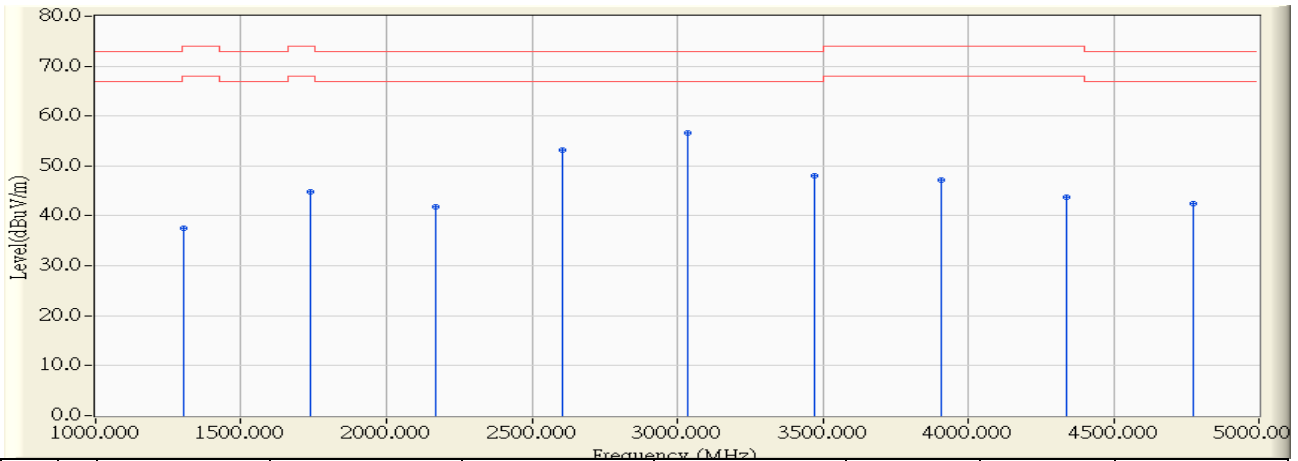

	Frequency (MHz)	Correct Factor (dB)	Reading Level (dBuV)	Measure Level (dBuV/m)	Margin (dB)	Limit (dBuV/m)	Detector Type
1	1301.550	-9.182	46.620	37.439	-36.561	74.000	PEAK
2	1736.150	-8.972	53.780	44.808	-29.192	74.000	PEAK
3	2169.250	-6.734	48.560	41.827	-31.043	72.870	PEAK
4	2603.990	-2.874	56.150	53.276	-19.594	72.870	PEAK
5	* 3037.920	-2.955	59.500	56.545	-16.325	72.870	PEAK
6	3471.970	-2.343	50.430	48.088	-24.782	72.870	PEAK
7	3906.000	-0.606	47.870	47.264	-26.736	74.000	PEAK
8	4338.420	-0.551	44.240	43.689	-30.311	74.000	PEAK
9	4773.750	-0.675	43.100	42.426	-30.444	72.870	PEAK

Note:

1. All Readings below 1GHz are Quasi-Peak, above are performed with peak and/or average measurements as necessary.
2. " * ", means this data is the worst emission level.
3. Measurement Level = Reading Level + Correct Factor.
4. The average measurement was not performed when the peak measured data under the limit of average detection. If the readings given are average, peak measurement should also be supplied.

Site : CB1	Time : 2015/05/07 – 17:00
Limit : NCC_3.4.2_H_433.92MHz_03M_AV	Margin : 6
Probe : CB1_FCC_EFS_1-18G-1_0901 - VERTICAL	Power : DC 3V
EUT : Tire Pressure Monitoring System (TPMS)	Note : 433MHz-Tx

		Frequency (MHz)	Peak Measurement (dBuV/m)	Duty Cycle Factor (dB)	Measurement Level (dBuV/m)	Margin (dB)	Limit (dBuV/m)	Detector Type
1		2603.990	-2.874	56.150	53.276	32.924	52.870	Average
2	*	3037.920	-2.955	59.500	56.545	36.193	52.870	Average

Note:

Peak Measure Value=Reading Value + Correct Factor

Average Measure Value=Peak Measure Value+20*LOG(Duty Cycle)

Duty Cycle=(Ton/(Ton+Toff))=8.7/90.6=0.096

20*LOG(Duty Cycle)=-20.352

3. Occupied Bandwidth

3.1. Test Equipment

The following test equipments are used during the radiated emission tests:

Occupied Bandwidth / SR7

Instrument	Manufacturer	Model No.	Serial No	Next Cal. Date
Spectrum Analyzer	Agilent	N9010A-EXA	US47140172	2015/07/14

Note: 1. All equipments that need to calibrate are with calibration period of 1 year.

3.2. Test Setup

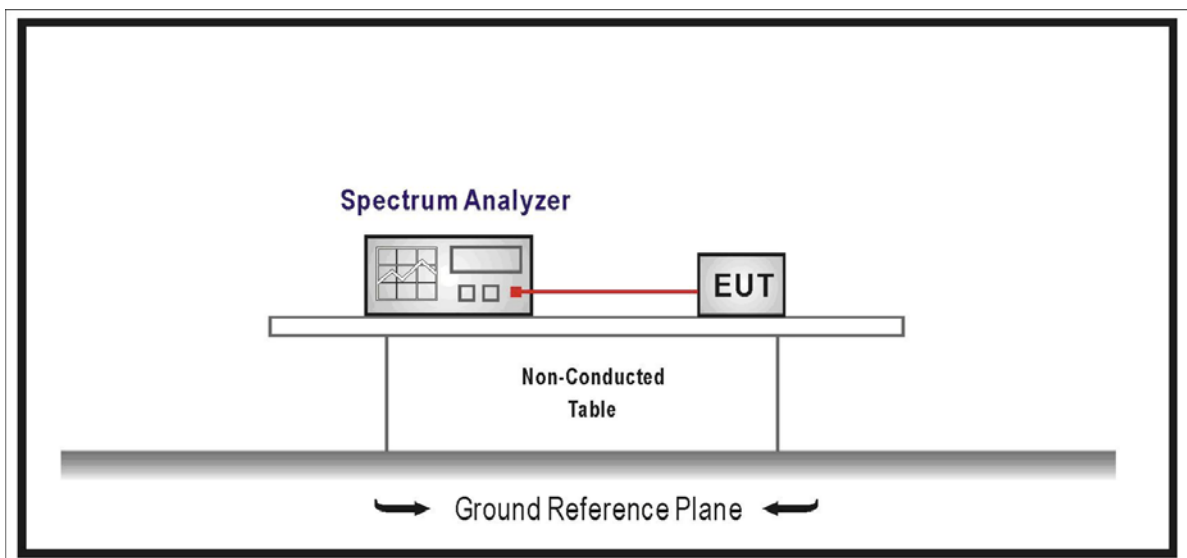

3.3. Limits

The bandwidth of the emission shall be no wider than 0.25% of the center frequency for devices operating above 70 MHz and below 900 MHz. For devices operating above 900 MHz, the emission shall be no wider than 0.5% of the center frequency. Bandwidth is determined at the points 20 dB down from the modulated carrier.

3.4. Test Specification

According to FCC Part 15 Subpart C Paragraph 15.231(b): 2012

3.5. Uncertainty

± 150Hz

3.6. Test Result

Product	Tire Pressure Monitoring System (TPMS)		
Test Item	Occupied Bandwidth		
Test Mode	Mode 1: Transmitter_Power by Battery (DC 3V)		
Date of Test	2015/05/07	Test Site	SR7

Center Frequency	433.920 MHz
Allowable Bandwidth (433.92 MHz: 0.25%)	1.08480 MHz
Bandwidth at 20dB down (Max)	960 kHz
Result	PASS

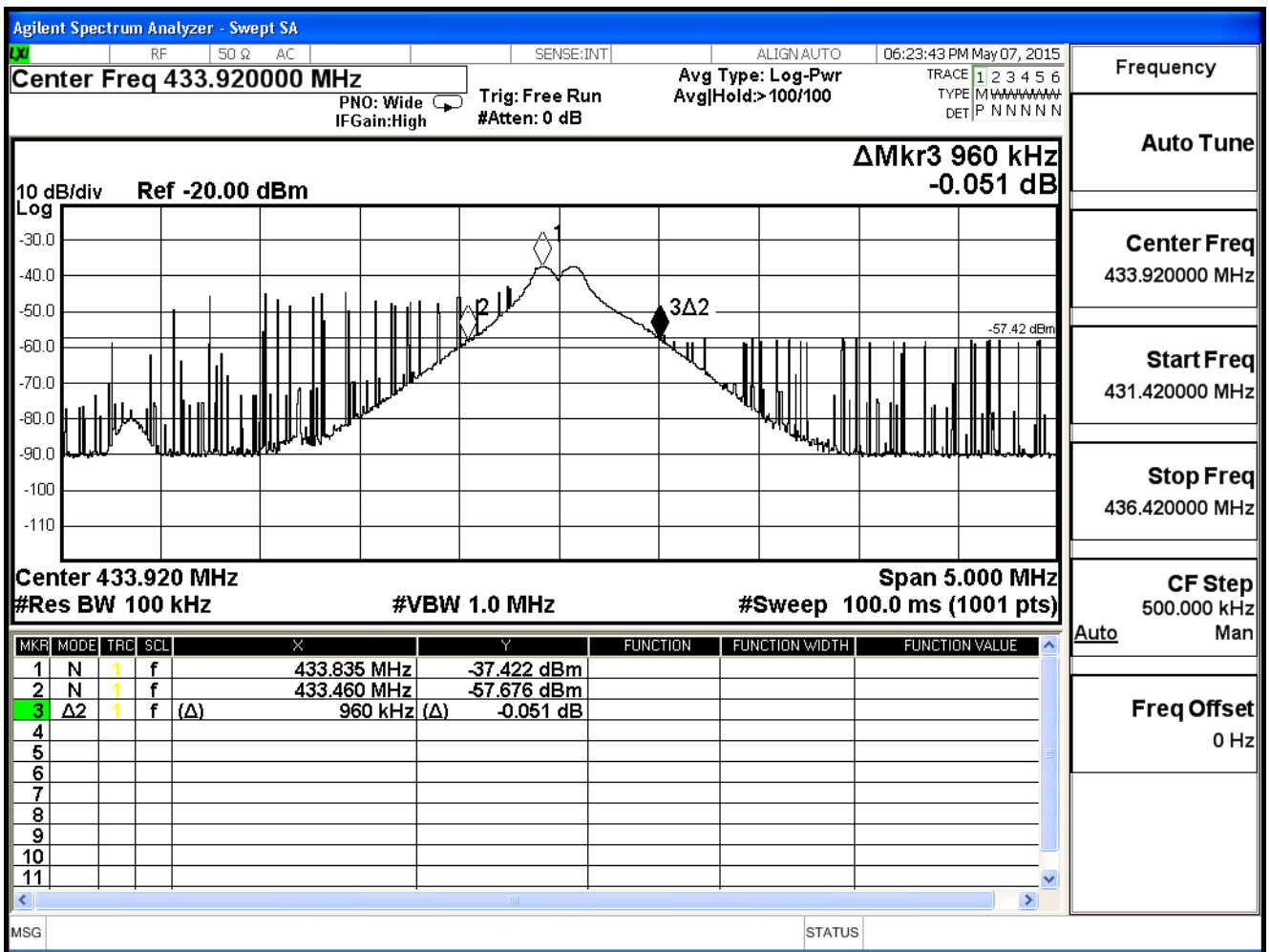

4. Duty cycle

4.1. Test Equipment

The following test equipments are used during the radiated emission tests:

Duty cycle / SR7

Instrument	Manufacturer	Model No.	Serial No	Next Cal. Date
Spectrum Analyzer	Agilent	N9010A-EXA	US47140172	2015/07/14

Note: 1. All equipments that need to calibrate are with calibration period of 1 year.

4.2. Test Setup

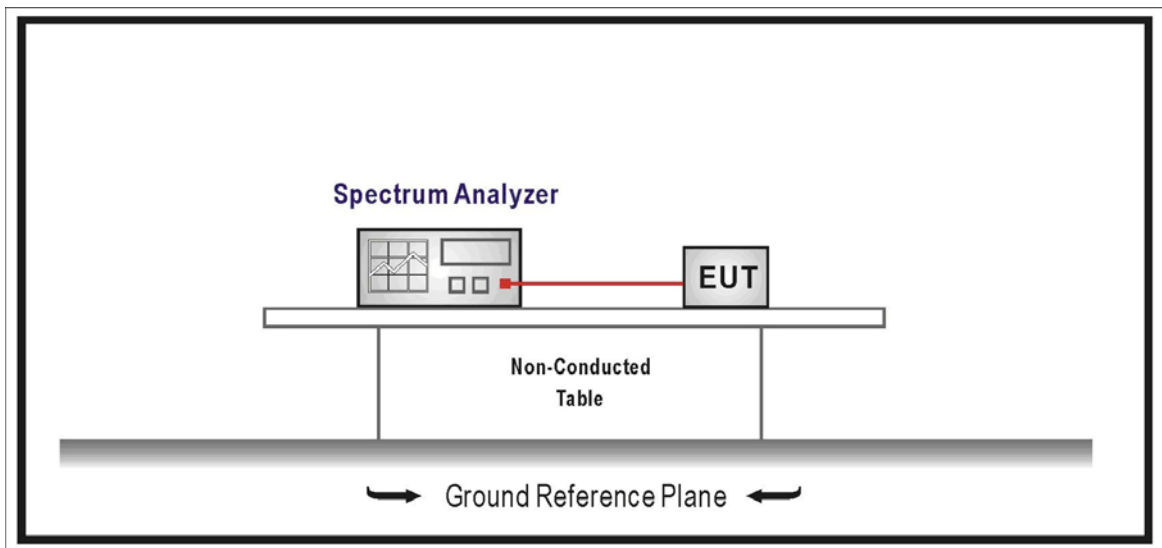

4.3. Limits

N/A

4.4. Test Specification

According to FCC Part 15 Subpart C Paragraph 15.231(b): 2012

4.5. Uncertainty

± 25msec

4.6. Test Result

Product	Tire Pressure Monitoring System (TPMS)		
Test Item	Duty Cycle		
Test Mode	Mode 1: Transmitter_Power by Battery (DC 3V)		
Date of Test	2015/05/07	Test Site	SR7

Center Frequency	433.920 MHz
Duty Cycle(Only Ton)	
= Ton/ Ton+off=(8.70ms/90.6ms)	
=0.096	

433.92 MHz

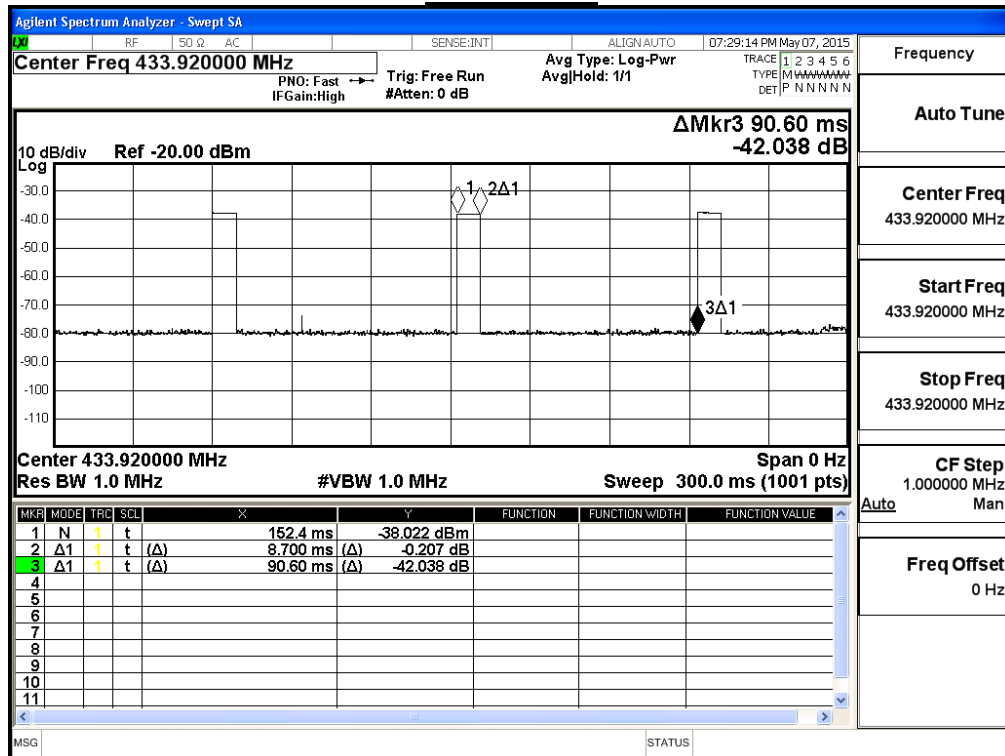

5. Transmitter time

5.1. Test Equipment

The following test equipments are used during the radiated emission tests:

Transmitter time / SR7

Instrument	Manufacturer	Model No.	Serial No	Next Cal. Date
Signal Analyzer	R&S	FSV7	101650	2015/12/17

Note: 1. All equipments that need to calibrate are with calibration period of 1 year.

5.2. Test Setup

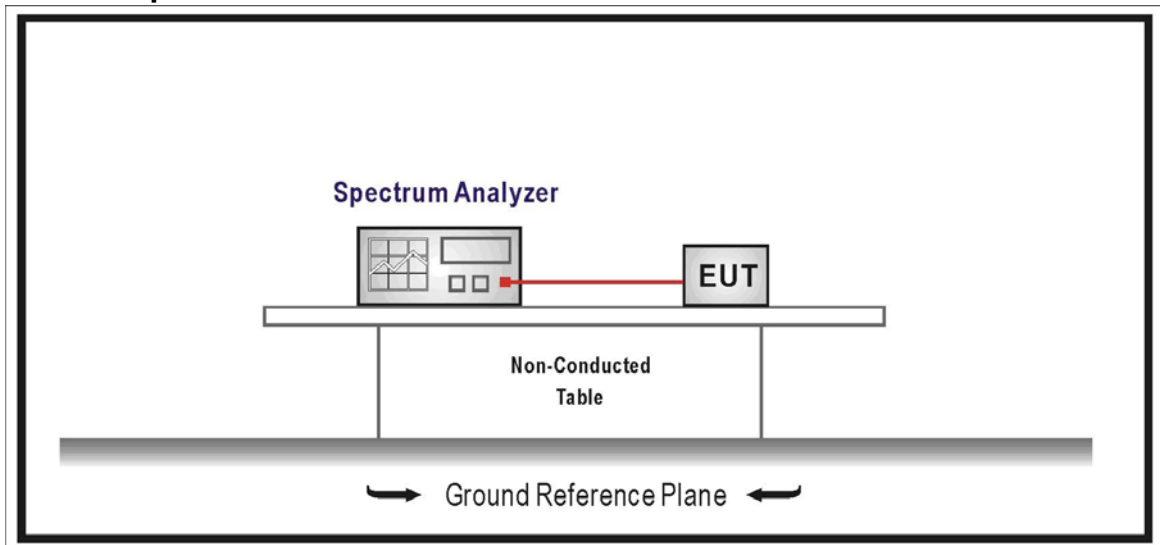

5.3. Limits

The duration of each transmission shall not be greater than one second and the silent period between transmissions shall be at least 30 times the duration of the transmission but in no case less than 10 seconds.

5.4. Test Specification

According to FCC Part 15 Subpart C Paragraph 15.231(b): 2012

5.5. Uncertainty

± 25msec

5.6. Test Result

Product	Tire Pressure Monitoring System (TPMS)		
Test Item	Transmitter time		
Test Mode	Mode 1: Transmitter_Power by Battery (DC 3V)		
Date of Test	2015/05/07	Test Site	SR7

Center Frequency	433.920 MHz
Transmitter time = 8.7ms < 5 sec.	Below 60.6 sec.
Result	PASS

Transmitter time in 300ms

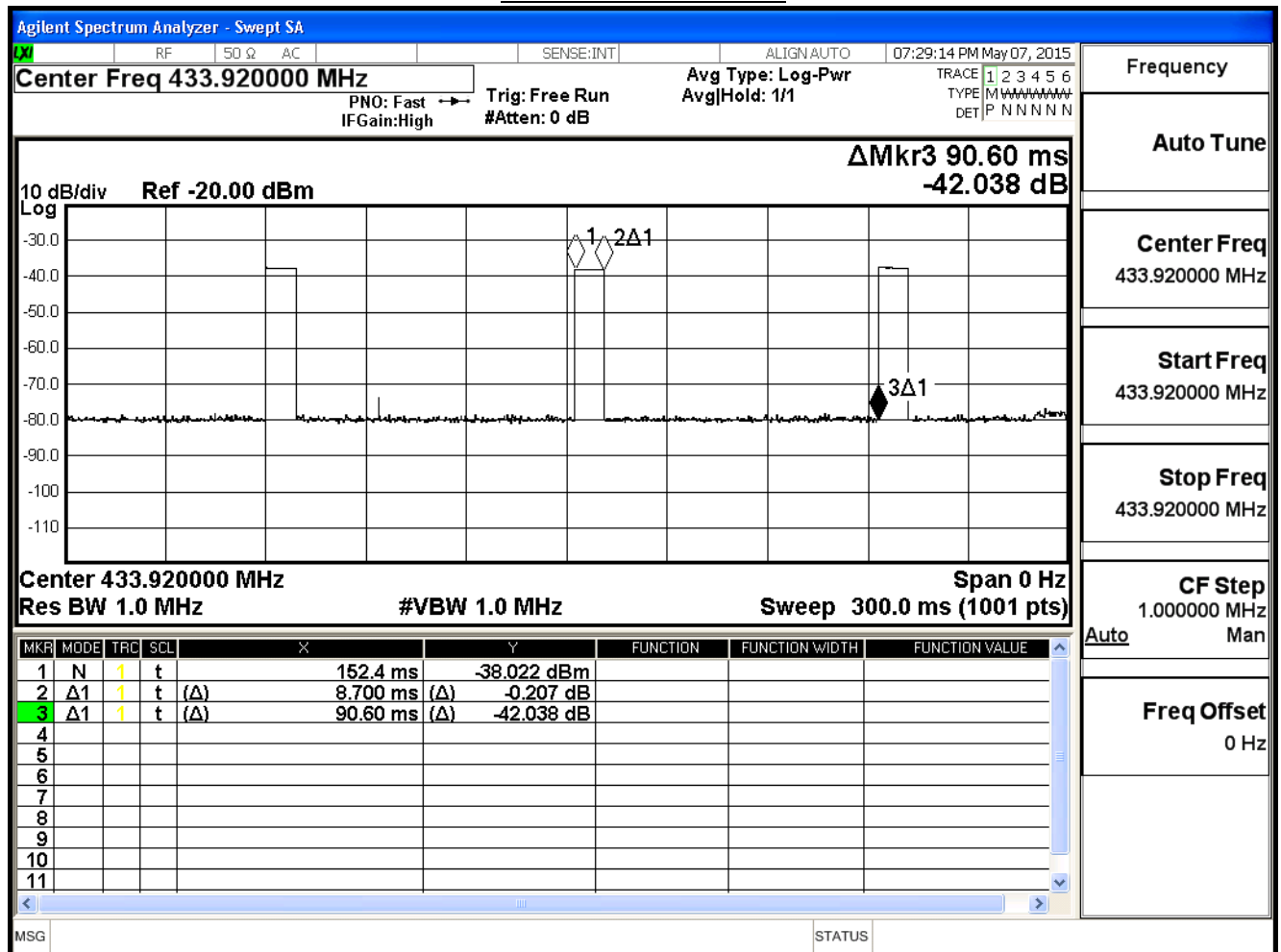

Total Transmitter time in 300sec.

