

SUNWAVE

INSTALLATION MANUAL



H2

Remote Unit iDAS-R311

HIGH POWER

Dual Band Digital Radios
43dBm per Band
Passive Cooling



Revision History

| Revision Number | Revision Date | Summary of Changes | Author |
|-----------------|-------------------------------|--------------------|----------------|
| 1.0.0 | 1 st November 2021 | Initial Release | Shuochao Zheng |
| | | | |
| | | | |
| | | | |
| | | | |
| | | | |

Copyright © 2022 Sunwave All rights reserved.

No part of this publication may be reproduced, transmitted, transcribed, stored in a retrieval system, or translated into any language, in any form or by any means, electronic, mechanical, photocopying, recording, or otherwise, without prior written permission from Sunwave.

All copyright, confidential information, patents, design rights, and all other intellectual property rights of whatsoever nature contained herein are and shall remain the sole and exclusive property of Sunwave. The information furnished herein is believed to be accurate and reliable.

However, no responsibility is assumed by Sunwave for its use or any infringements of patents or other rights of third parties resulting from its use.

The Sunwave and CrossFire names and logos are trademarks or registered trademarks of Sunwave.

All other trademarks are the property of their respective owners.



Content

Overview.....5

Preface 8

Safety Instructions 8

 Site Considerations 9

 Environmental Considerations..... 9

 DC Power Connections..... 10

 Warning Marks..... 11

 Unpacking and Inspecting..... 12

 Inspecting the Packing Container 12

 Unpacking the Device 12

 Verifying the Contents 12

 Inspecting the Device..... 12

 Installation Preparation 13

 Site Investigation..... 13

 Installation Tools..... 13

 Torque Settings 13

 Clearance 13

Installation of the A2..... 14

 Mount the A2 in the Rack 15

 A2 Accessories..... 15

 Attach A2 Handle 16

 Attach Sliding Rails and A2 to Rack..... 16

 Fan Installation..... 17

 Connect Power and Ground Cable to A2 18

 DC Power Connections..... 19

 Attach Handle to A2 19

 Mount A2 to Wall..... 19

 Connect Power and Ground Cable to A2 20

 A2 Mounting Dimension Spacing..... 20

Installation of the E2-O 22

 Mount the E2-O in the Rack..... 22



HIGH POWER

43dBm Dual Band
Digital Radio

| | |
|---|----|
| E2-O Accessories | 22 |
| Attach E2-O Handle | 23 |
| Attach Sliding Rails and E2-O to Rack | 23 |
| Connect Power and Ground Cable to E2-O | 24 |
| Mount the E2-O on the Wall | 25 |
| Attach Handle to E2-O | 25 |
| Mount E2-O to Wall | 25 |
| Connect Power and Ground Cable to E2-O | 26 |
| E2-O Mounting Dimension Spacing | 27 |
| Installation of the H2RU | 28 |
| Accessories List | 28 |
| Wall Installation (Back on the Wall) | 29 |
| Wall Installation (Side on the Wall) | 34 |
| Pole Installation | 39 |
| H2RU Mounting Dimension Spacing | 40 |
| Optical Connection | 41 |
| Optical Transceiver Module | 41 |
| Single Port Bidirectional SFP Transceiver | 41 |
| Dual Port SFP Transceiver | 41 |
| Optical Indicator | 42 |
| A2 Optical Port Description | 43 |
| E2-O Optical Port Description | 43 |
| RU Optical Port Description | 45 |

Overview

CrossFire H2 is a digital transport platform supporting cellular and wideband public safety technologies on fibre optic cable using the CPRI protocol. The power amplifier technology adopts Digital Pre-Distortion, allowing for a significant improvement in power consumption compared with analogue technology. This platform is ideal for multi-operator multi-band deployments of cellular services into large coverage areas, and as an alternative for single operator RAN solutions. The product is used in industrial environment, and doesn't support home/personal use.

Key Features

- Up to 43dBm Output Power per Band
- External Alarm Interface
- Optical cascading of E2-O's & RU's

- 2 x 3GPP Bands per Remote
- 600 to 6000MHz Range
- Up to 100MHz per Band

System Elements

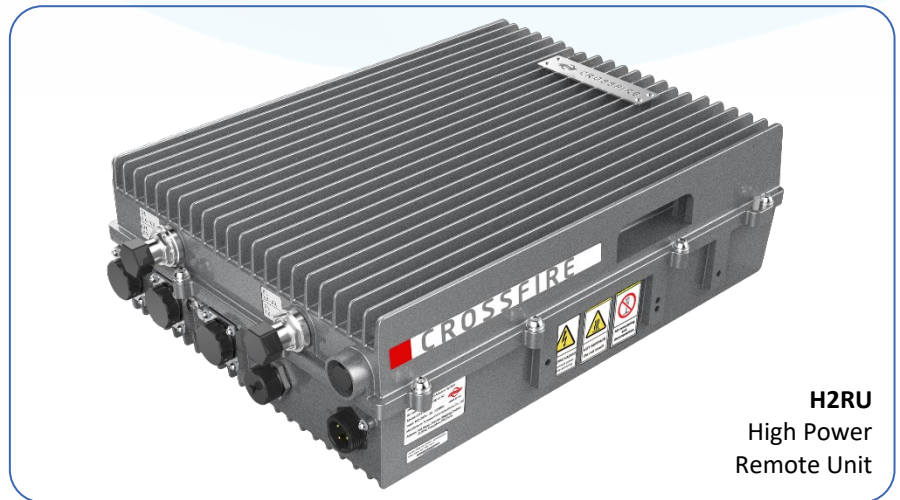
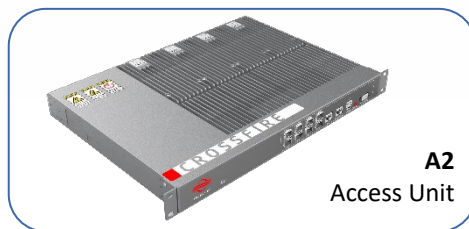

Block Diagram

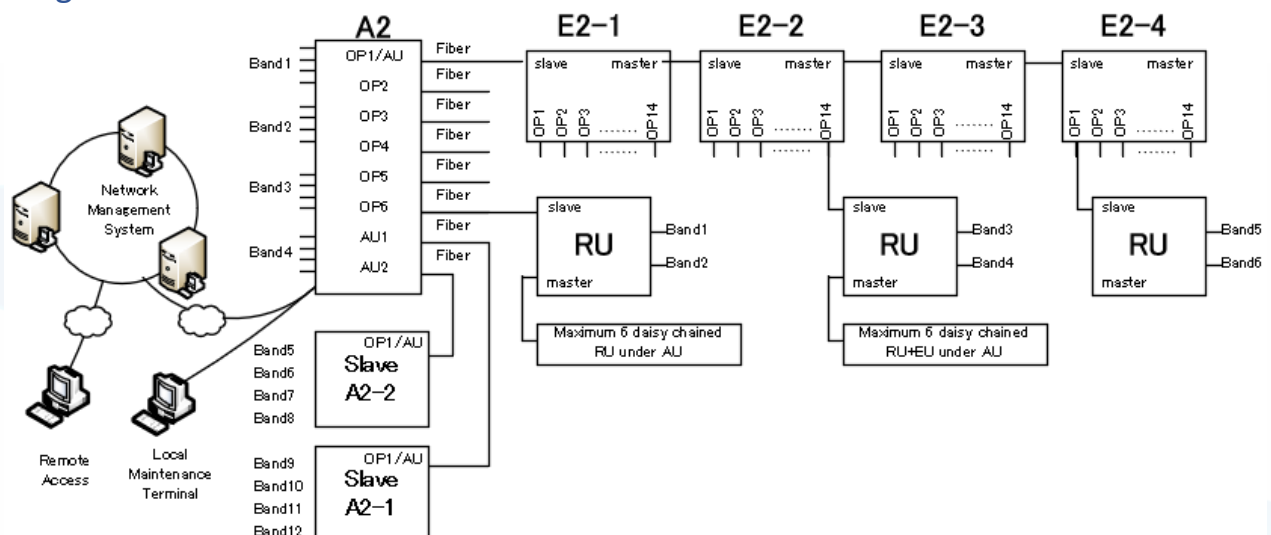



Technical Specifications

| System | |
|---|---|
| Maximum RF Bands per Access Unit | 4 |
| Maximum RF Bands per Remote Unit | 2 |
| Maximum RF Bands per System | 12 |
| Maximum Access Units per System | 3 (1 x Master / 2 x Slaves) |
| Maximum EUs per Master A2 | 8 |
| Maximum EUs cascaded | 5 |
| Maximum RUs cascaded | 6 |
| Frequency Range (Non-Contiguous) | 600MHz – 6000MHz |
| Bandwidth per Channel (Downlink & Uplink) | ≤100MHz (Contiguous) |
| Digital Bandwidth per Channel (Downlink & Uplink) | 20 / 30 / 40 / 50 / 60 / 80 / 100 MHz |
| Bandwidth per System (Downlink & Uplink) | ≤400MHz (in each direction) |
| MIMO | 2x2: 1 x RU 4x4: 2 x RU 8x8: 4 x RU |
| System Delay Adjustment | Up to 80.00μs |

| Forward Path (Downlink) | |
|-------------------------|------------------------------------|
| Output Power Accuracy | ±2dB |
| Maximum Gain | 43 ± 1dB |
| Maximum Input Power | +15dBm |
| Error Vector Magnitude | <3.5% @ 256 QAM ¹ |
| Ripple | 3dB Typical |
| Manual Gain Control | 45dB @ 1dB/step (AU:30dB, RU:15dB) |
| System Delay (AU+EU+RU) | 12μs |
| VSWR (AU/RU) | 1.5:1 |



Technical Specifications

Supported Bands

| Band | 3GPP Band | Uplink(RX) | Downlink(TX) | Max Bandwidth |
|------|-----------|------------|--------------|---------------|
| PCS | 25 | 1850-1915 | 1930-1995 | 65 |

Note: The unit is MHz.

Interfaces

| | |
|-------------------------------|--|
| Antenna Interface (All bands) | 4.3-10 Female |
| Antenna Gain | 12dBi |
| Access Unit RF Interface | QMA Female |
| Optical Connector Type | SFP+, Standard LC |
| Optical Transmission Rate | 10.1376Gb/s |
| Optical Fibre Length | 1.4km / 10km / 30km 0.87mi / 6.21mi / 18.64mi |
| Physical Alarms | DB9, Female (4x in, 4x out) |
| Maintenance Interface | Ethernet RJ45 / Wi-Fi / USB |

Electrical

| | |
|--|-------------------------------|
| Electromagnetic Compatibility/Interference (EMC/EMI) | 3GPP TS36.113 3GPP TS25.113 |
| Maximum Power Consumption (A2/E2-O/RU) | 80W / 60W / 250W |
| AC Power | 100-240V AC, 50/60Hz |
| DC Power | 48VDC \pm 20% (A2/E2-O) |

Technical Specifications

Environmental

| | |
|----------------------------------|--|
| Mean Time Between Failure (MTBF) | >100,000 hours |
| Operating Temperature (A2/E2) | -10°C to +50°C / 14°F to +122°F |
| Operating Temperature (RU) | -40°C to +50°C / -40°F to +122°F |
| Storage Temperature | -40°C to +70°C / -40°F to +158°F |
| Humidity | 5% to 85% (Non-Condensing) |
| Cooling | Passive |
| Installation | A2/E2: Wall or 19" Rack RU: Wall or Pole |
| Ingress Protection Rating | A2/E2: IP30 (Indoor) RU: IP65 (Outdoor) |

Mechanical

| | |
|--------------------------------------|--|
| A2 (Width / Height / Depth / Weight) | 440mm / 44mm / 329mm / 8.0kg 17.32in / 1.73in / 12.95in / 17.64lb |
|--------------------------------------|--|

Contact us today:

www.sunwave.com

cf_support@sunwave.com

SUNWAVE

© Sunwave IM_CF_H2 v1.0.0 | 7 of 47



| | |
|--|--|
| E2-O (Width / Height / Depth / Weight) | 440mm / 44mm / 220mm / 5.0kg 17.32in / 1.73in / 8.66in / 11.02lb |
| H2RU (Width / Height / Depth / Weight) <i>excluding Bands 12, 13 & 14</i> | 400mm / 125mm / 300mm / 16.0kg 15.75in / 4.92in / 11.81in / 35.27lb |
| H2-7 (Width / Height / Depth / Weight) <i>for Bands 12, 13 & 14</i> | 400mm / 135mm / 300mm / 18.0kg 15.75in / 5.31in / 11.81in / 39.68lb |

Element Management

| | |
|---|--|
| OMT (Operations and Maintenance Terminal) | Yes. Access via A2, E2 or RU (Web Based) |
| LMS (Local Management System) | Yes (Ordered separately) |
| NMS (Network Management System) | Yes (Ordered separately) |

Preface

Safety Instructions

 All the following “Safety Precautions” must be observed during the entire installation and operation of the CrossFire system.

The CrossFire system components are designed for maximum safety and reliability when they are installed, used, and maintained by trained and qualified technicians in accordance with the procedures and instructions contained in this manual. To assure the safe operation of your system, always follow the safety and operational recommendations in this manual.

1. The shells of the device have protective ground terminals. During installation, connect the ground terminals securely to the protective building ground with yellow and green conductors or with braided ground wire. The aerial and feeder must be adequately grounded.
2. The power source must be within the required range of the device. The rated voltage range for the AC power supply system is 100 ~ 240VAC, and the rated frequency range is 50Hz / 60Hz. The rated power of the A2, E2, and H2RU is 80W, 60W, and 250W, respectively. The ground terminal of the three-core power socket used at the device installation site must be securely connected to the protective building ground.
3. To avoid injuries or damage, use care, and obtain assistance before lifting any heavy system components or equipment.
4. While fiber optic power levels used in this system are very low, it is advisable to avoid exposing the human eye to the laser light emanating from a fiber port or plug.
5. Signals coupled from the BTS shall be no greater than +15dBm, otherwise, the device will not operate normally, and damage may occur to the circuit.
6. Reserve at least 40mm of height above the radiation fins during device installation; otherwise, the device temperature may rise and affect the service life of the device.
7. Please use Shielded Twisted Pair (STP) cables for WLAN application.
8. Low path loss cables connected to antennas are highly recommended.



Site Considerations

1. CrossFire complies with FCC RF exposure limits for an uncontrolled environment. This equipment must be installed and operated with a minimum distance of 400 cm for H2RU between the antennas and any person's body.
2. The system delay should be taken into consideration when there are neighboring BTS sites that are overlapping in coverage. Normal use of the system will not damage the base station; however, with the increase of RU during network coverage for indoor distribution, the uplink output noise level may affect the sensitivity of the base station, which should be considered during engineering design. Pick an ideal easy-to-reach location for installation convenience.
3. Pick an ideal easy-to-reach location for installation convenience.
4. Verify that there is a minimum of a 50cm radius of space around CrossFire equipment for the convenience of maintenance and on-site inspection.
5. Install CrossFire close to the service area for monitor and debugging.

Environmental Considerations

Humidity and temperature can adversely affect reliability of the CrossFire system. Therefore, it is highly recommended to install the equipment in locations with stable humidity, temperature, and ventilating.

The equipment has to operate at humidity level and temperature range as follow:

- ✧ Maximum humidity: 85%
- ✧ Operating Temperature range: -10°C to +50°C
- ✧ Storage Temperature range: -25°C to +70°C

DC Power Connections

Referring to the diagram, connect the power cables as follows:

Higher voltage wire linked to **RED** cable / Lower voltage wire linked to **BLUE** cable.

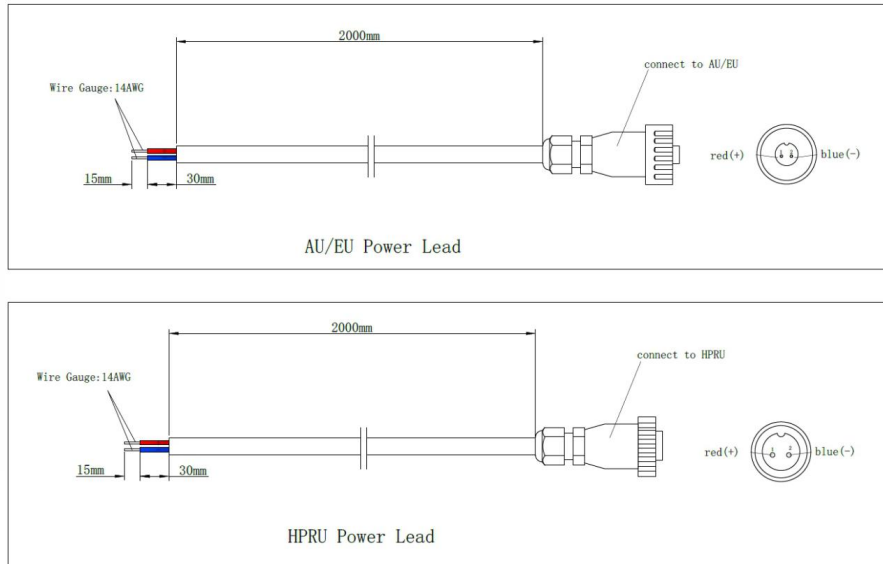

- ✧ Connect "+" to a high potential (+48VDC from a +48VDC power supply; 0VDC from a -48VDC power supply)
- ✧ Connect "-" to a low potential (0VDC from a +48VDC power supply; -48VDC from a -48VDC power supply)



| Cable Core | Cable Length | Maximum Expandable Length |
|------------|--------------|---------------------------|
| 14AWG | 2m | 10m |

Warning Marks

The warning marks on the CrossFire shell should be kept clean, readable, and identifiable.



ALWAYS disconnect all lines and power connections before servicing or disassembling this equipment.



NEVER touch the surface after the device's power on.



For performance and safety reasons, **NEVER** disassemble and remodel the devices.



Installation Preparation

Unpacking and Inspecting

This section discusses the procedures for receiving the shipment, inspecting the packing container, unpacking, and inspecting the device.

Inspecting the Packing Container

Handle the packing container carefully. Inspect the packing container immediately on arrival at the installation site to verify that no obvious damage occurred during shipment. Ensure that the container is sound and that the waterproof and vibration warning notices are still obvious. If possible, always inspect the equipment in the presence of the delivery person.

If any damage is observed:

1. Do not open or unpack the container.
2. Immediately contact the transportation carrier and notify them of the damage.
3. File a claim with the carrier once you determine the extent of any damage.
4. Return it to SUNWAVE's nearest RMA facility and contact SUNWAVE for RMA processing.

Unpacking the Device

If the container appears to be in satisfactory condition:

1. Ensure both user and supplier representatives are in attendance during shipment inspection.
2. Confirm where you will store the device.
3. Ensure procedures are in place to handle the device and other equipment properly.
4. Ensure the following tools are available to unpack the shipment: hammer, paper cutter, and crowbar.
5. Open the packing container carefully. The device is contained in a protective package inside the packing container; however, caution is still necessary so as not to damage the internal package and device.
6. Remove the internal package from the packing container.
7. Unpack the device from the internal package carefully.

Verifying the Contents

To verify the contents of the package:

1. Verify that the contents and quantities agree with the Delivery Packing List.
2. Check the device model against the Delivery Packing List.
3. Notify SUNWAVE immediately if any discrepancies are discovered, to verify whether the complete and correct shipment has been received.

Inspecting the Device

After unpacking the device, place the device on solid ground and check the following to ensure the device has not been damaged:

Contact us today:

www.sunwave.com

cf_support@sunwave.com



1. Inspect the device’s appearance, overall dimensions, and weight.
2. Check that the device has not been deformed or bent in any way.
3. Check that there are no warps, scratches, bubbles, or dirt marks.
4. Check that there are no loose, missing or incorrectly fastened screws.
5. Check that the installation slots in the cabinet sub-rack are rectangular.
6. Ensure that the guide bar has not been damaged and the fittings and auxiliary parts are intact.
7. Check that the silk-screened images on the device are visible and intact.

Installation Preparation

Site Investigation

Before installation, the installer should contact the project director to ensure that the site is suitable for installation. Details required include information about the installation site, such as whether there is an iron tower or high mast nearby, the surrounding environmental conditions such as temperature and humidity, the power source, and so on. Installation staff should complete a site investigation with the project director before construction and conduct field observation of the installation site and the coverage area of the device, to confirm factors such as signal intensity, signal quality, the required coverage range, device location, antenna-feeder system, and power supply system.

Note: Only maintenance personnel or users who understand the reason for access and are experienced with restricted area access and understand the necessary preventive measures should access the installation site.

Installation Tools

The following equipment and tools are required for a successful installation:

Electric percussion drill / Screwdriver / Wrench

Torque Settings

| Type | M3 | M6 | M10 |
|-------------------|-------|-----|------|
| Specified Torques | 0.6Nm | 5Nm | 50Nm |

Clearance

You must ensure the following mounting clearances for mounting within a 19” rack/cabinet:

✧ Convection cooling:

Maintain 3U clearance between the bottom of the device and any other.

Maintain 3U clearance from the top surface of the device to the top of the rack.

✧ FAN Cooling:

You can mount the fan between the bottom of the device and any other.

Maintain 2U clearance between the bottom of the device and any other.

Contact us today:

www.sunwave.com

cf_support@sunwave.com



HIGH POWER

43dBm Dual Band
Digital Radio

You must ensure the following mounting clearances for wall mounting:

✧ Convection cooling:

Maintain 150mm clearance from the bottom of the device to any other planar obstructions.

Maintain 150mm clearance from the top of the device to any other planar.

Maintain 150mm clearance from both sides of the device to any other planar obstructions.

Installation of the A2

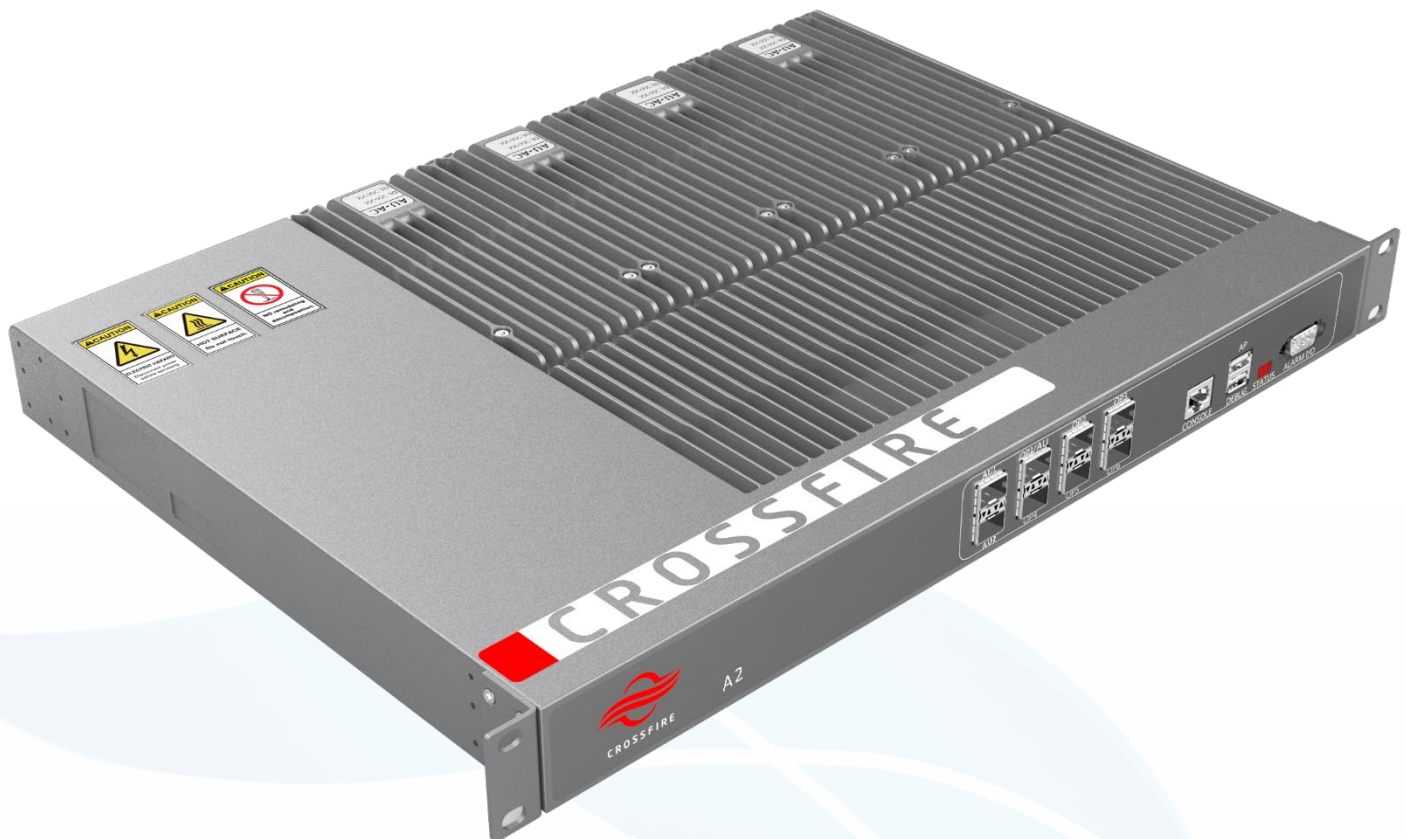







Contact us today:
www.sunwave.com
cf_support@sunwave.com

SUNWAVE

© Sunwave IM_CF_H2 v1.0.0 | 14 of 47

Mount the A2 in the Rack

A2 Accessories

| | | |
|---|--|---|
| | ① Screw M6*16 | ② Screw M3*6 |
| |  |  |
| ③ Suspension Loop | ④ AC Power Lead 2.5m | |
|  |  | |
| ⑤ CAT-5 Cable 1.5m | ⑥ Ground Wire 2m | |
|  |  | |

A2 Accessories

Note: the ground wire of A2 is 12AWG and 2 meter in Accessories package.

Attach A2 Handle

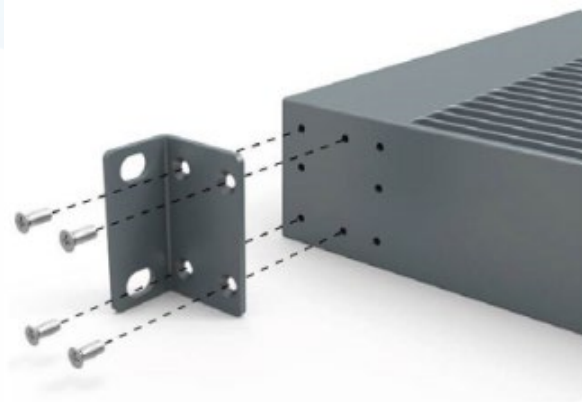

Attaching a 19" Mounting Bracket

1. Attach the 19" mounting brackets at the front of the A2, using 4 screws M3×16 per bracket and the Phillips screwdriver. Observe the orientation of the brackets.

Attach Sliding Rails and A2 to Rack

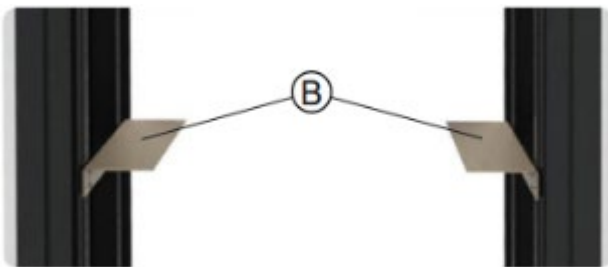

Attached Sliding Rails

1. Attach the sliding rails **B** to the rack.

Note: the sliding rails are not included in the delivery.



Place A2 in Rack

2. Place the A2 in the rack.

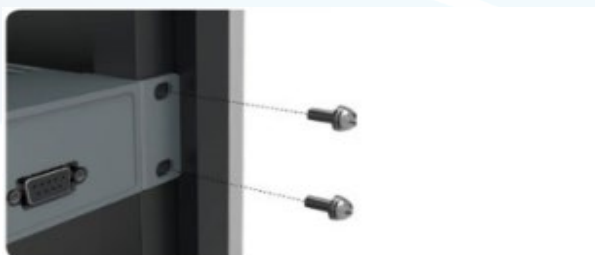

Fix A2 with Screws

3. Secure the A2 using 2 screws M6×16 on both sides and the Phillips screwdriver.

Contact us today:

www.sunwave.com

cf_support@sunwave.com



CROSSFIRE

HIGH POWER

43dBm Dual Band
Digital Radio



Separation of Adjacent A2

For rack installation, it is highly recommended to use a fan tray in the middle of 2 adjacent A2 for cooling.

Note: It will reduce service life if A2 is continuously working in environment of high temperature.

Fan Installation



Fix Fan with Screws

1. Secure the Fan using 2 screws M6×16 on both sides and the Phillips screwdriver



Plug AC Power Lead

2. Plug AC power lead.



CROSSFIRE

HIGH POWER

43dBm Dual Band
Digital Radio



Fan DC Version

Fan DC version has power cable embedded in chassis.

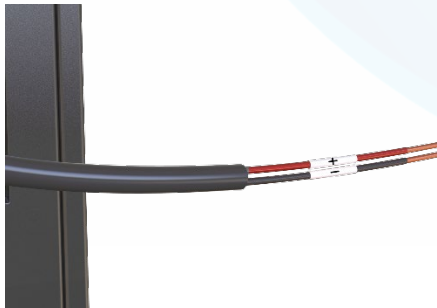

DC Power Cable

Note: Red is for positive; Blue is for negative.

Connect Power and Ground Cable to A2



Connect Power Cable at Rear Side

1. Connect and lock the power cable at the rear of the A2.



Connect Ground Cable at Rear Side

2. Connect and screw the ground wire at the rear of the A2.

Contact us today:
www.sunwave.com
cf_support@sunwave.com

SUNWAVE

© Sunwave IM_CF_H2 v1.0.0 | 18 of 47

DC Power Connections

Attach Handle to A2

Attach the 19" mounting brackets to the rear of the A2 unit, using 4 screws M3×16 per bracket and the Phillips screwdriver. Observe the orientation of the brackets shown in 0.

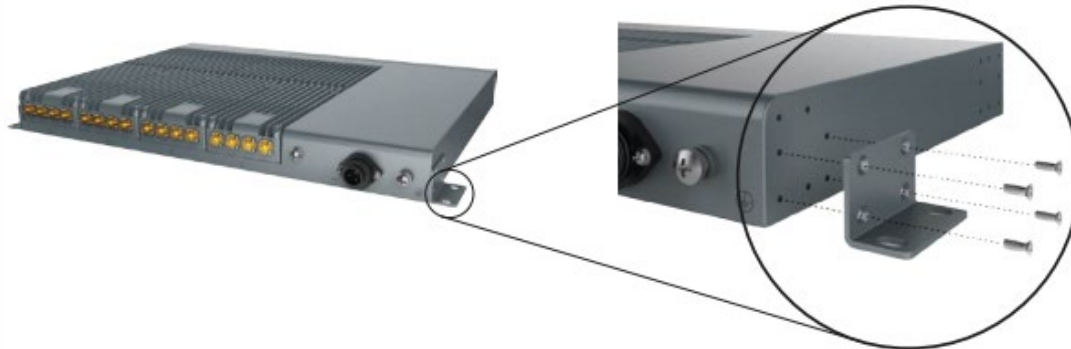

Attaching a 19" Mounting Bracket

Mount A2 to Wall

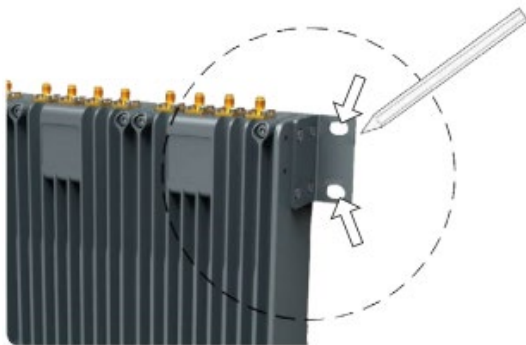

Marking the position of mounting holes

1. Hold the A2 to the installation location and mark the position of the 4 mounting holes in the mounting brackets.
2. Drill the mounting holes according to the chosen mounting accessories.
3. Attach the dowels, expansion screws, or the similar and fasten the A2 to the wall.

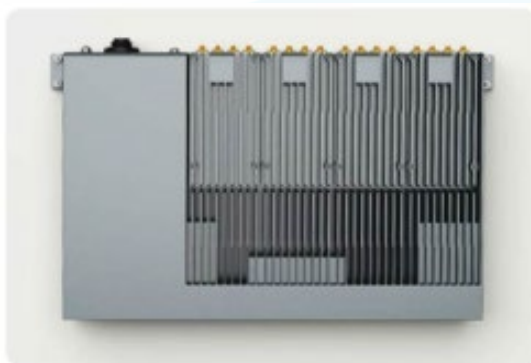

Mounting completed

Contact us today:

www.sunwave.com

cf_support@sunwave.com

Connect Power and Ground Cable to A2



Connect power cable at the rear of the unit



Connect ground cable at the rear of the unit

1. Connect and lock the power cable at the rear of the A2.

1. Connect and screw the ground wire at the rear of the A2.

A2 Mounting Dimension Spacing



CROSSFIRE

HIGH POWER

43dBm Dual Band
Digital Radio

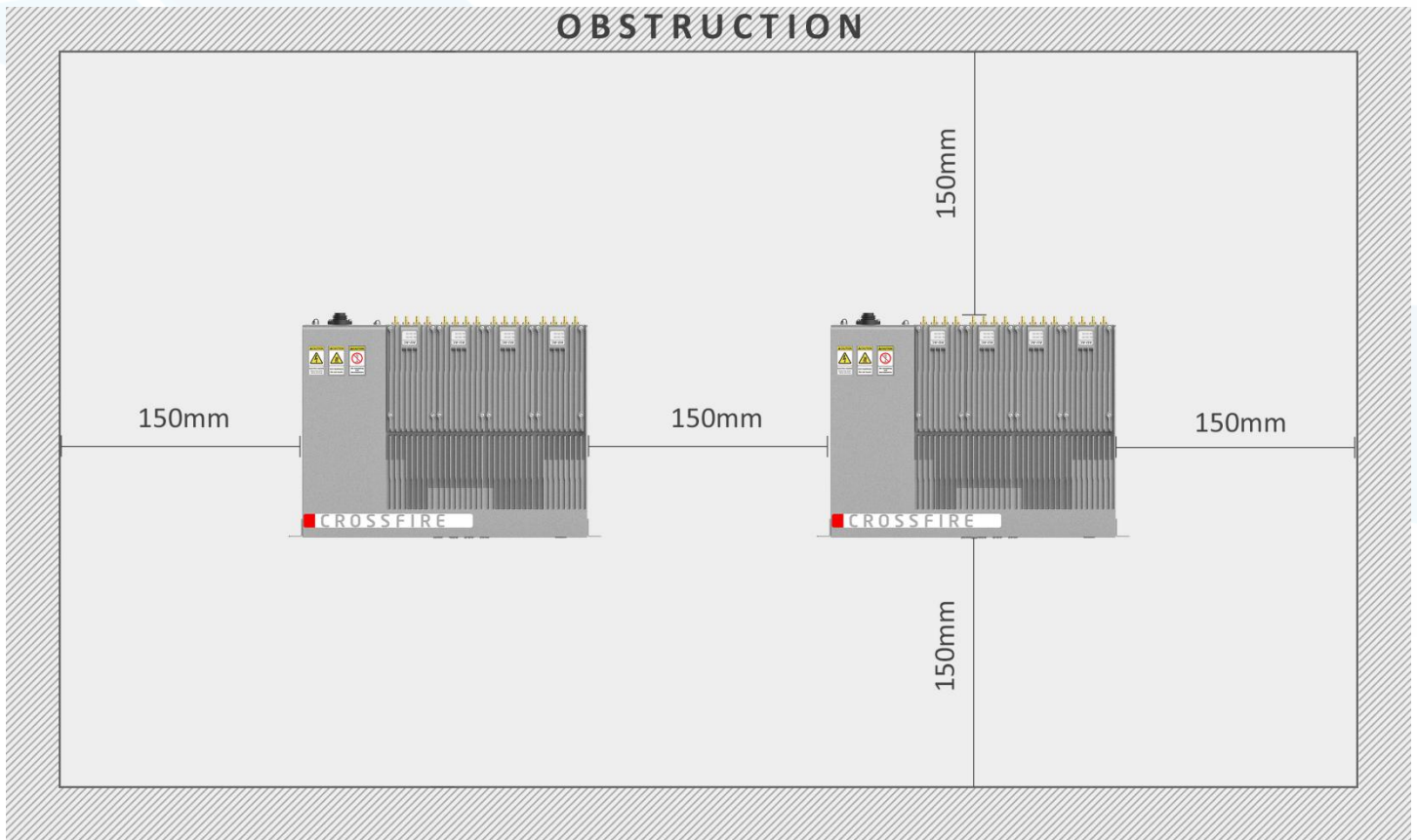

Contact us today:
www.sunwave.com
cf_support@sunwave.com

SUNWAVE

© Sunwave IM_CF_H2 v1.0.0 | 21 of 47







Installation of the E2-O

Installing the E2-O is virtually the same as installing the A2. Please refer to the steps described in the A2 installation for the E2-O.



Mount the E2-O in the Rack

E2-O Accessories

| | | |
|---|--|--|
| | ① Screw M6×16 | ② Screw M3×6 |
| |  |  |
| ③ Suspension Loop | ④ AC Power Lead 2.5m | |
|  |  | |
| ⑤ Optical Transceiver | ⑥ Ground Wire 2m | |
|  |  | |

E2-O Accessories

Note: the ground wire of E2-O is 12AWG and 2 meter in Accessories package.

Attach E2-O Handle

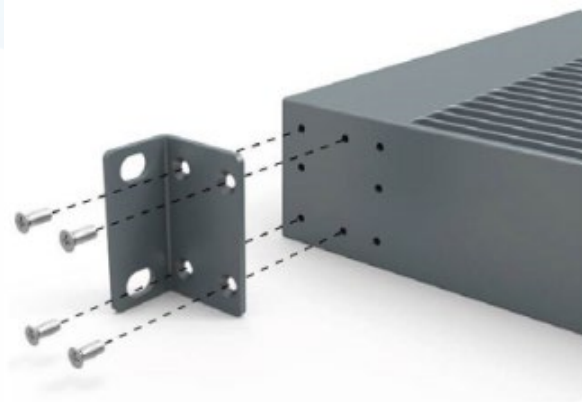

Attaching a 19" Mounting Bracket

1. Attach the 19" mounting brackets at the front of the E2-O, using 4 screws M3×16 per bracket and the Phillips screwdriver. Observe the orientation of the brackets.

Attach Sliding Rails and E2-O to Rack

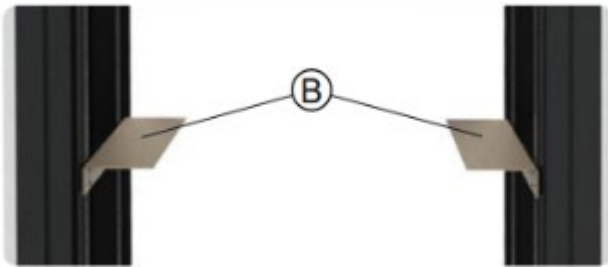

Attached Sliding Rails

1. Attach the sliding rails **B** to the rack

Note: the sliding rails are not included in the delivery.



Place E2-O in Rack

2. Place the E2-O in the rack

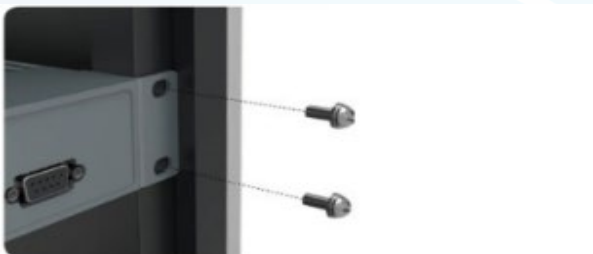

Fix E2-O with Screws

3. Secure the E2-O using 2 screws M6×16 on both sides and the Phillips screwdriver.

Contact us today:

www.sunwave.com

cf_support@sunwave.com



CROSSFIRE

HIGH POWER

43dBm Dual Band
Digital Radio

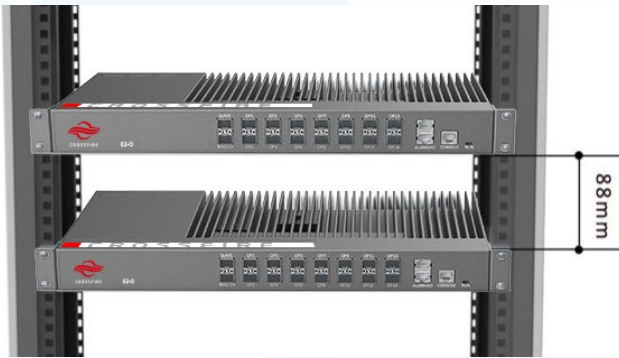

Separation of Adjacent E2-O

For rack installation, it is highly recommended to use a fan tray in the middle of 2 adjacent E2-O for cooling.

Keep 2U separation of 2 E2-O if there is no fan for cooling.

Note: It will reduce service life if E2-O is continuously working in environment of high temperature.

Connect Power and Ground Cable to E2-O



Connect Power Cable at Rear Side



Connect Ground Cable at Rear Side

1. Connect and lock the power cable at the rear of the E2-O.

2. Connect and screw the ground wire at the rear of the E2-O.

Mount the E2-O on the Wall

Attach Handle to E2-O

Attach the 19" mounting brackets to the rear of the E2-O, using 4 screws M3×16 per bracket and the Phillips screwdriver. Observe the orientation of the brackets.



Attaching a 19" Mounting Bracket

Mount E2-O to Wall



Marking the Position of Mounting Holes

1. Hold the E2-O to the installation location and mark the position of the 4 mounting holes in the mounting brackets; see arrows in 0
2. Drill the mounting holes according to the chosen mounting accessories.



Mounting Completed

1. Attach the dowels, expansion screws, or the similar and fasten the E2-O to the wall.

Contact us today:

www.sunwave.com

cf_support@sunwave.com

Connect Power and Ground Cable to E2-O



Connect power cable at the rear of the unit



Connect ground cable at the rear of the unit

1. Connect and lock the power cable at the rear of the E2-O
2. Connect and screw the ground wire at the rear of the E2-O



HIGH POWER

43dBm Dual Band
Digital Radio

E2-O Mounting Dimension Spacing

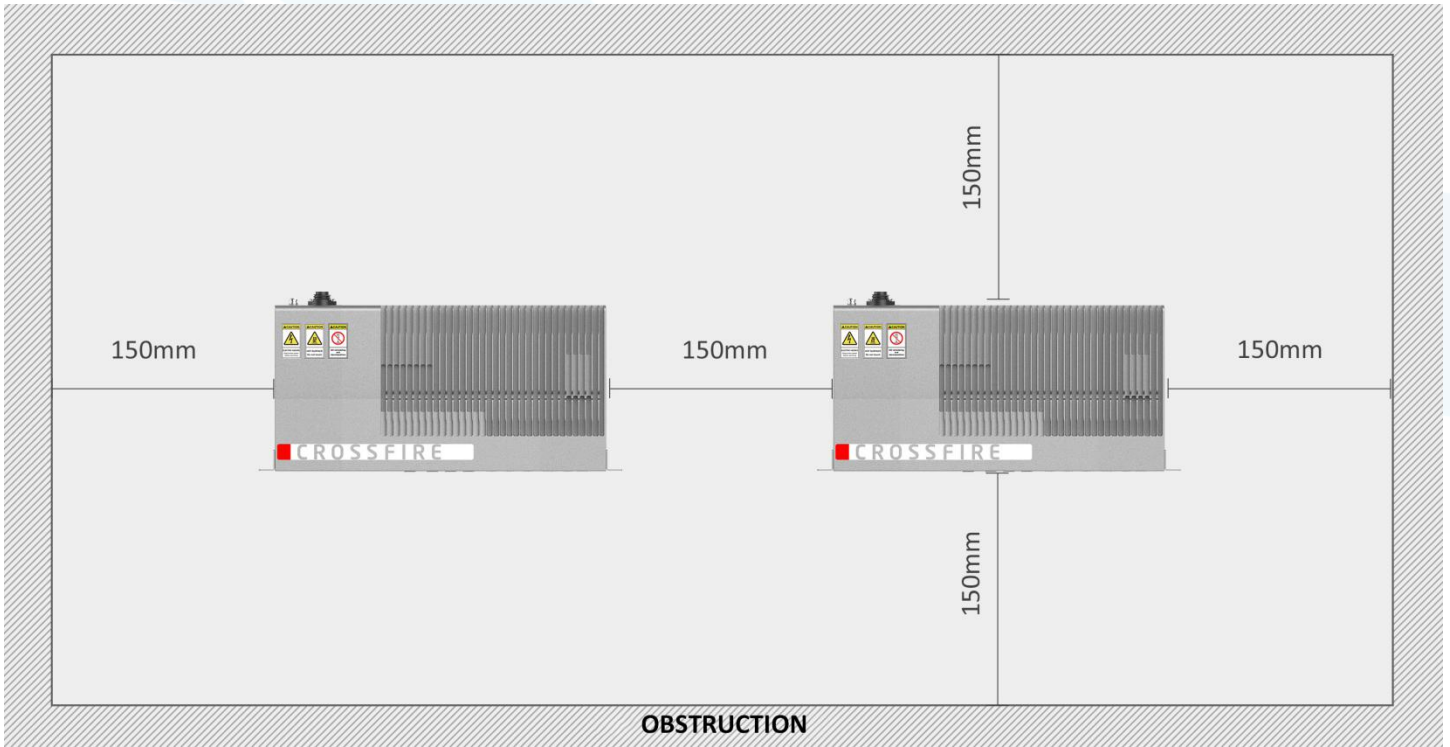

Contact us today:
www.sunwave.com
cf_support@sunwave.com

SUNWAVE

© Sunwave IM_CF_H2 v1.0.0 | 27 of 47

Installation of the H2RU



Accessories List

| HPRU Accessories List | | | |
|--|---|--|--|
| ① Nut M10 | ② Screw M6×14 | ③ Flat Washer M10 | ④ Spring Washer M10 |
|  |  |  |  |
| ⑤ Handle | | ⑥ Expansion Bolt M10×90 | |
|  | |  | |
| ⑦ Optical Transceiver FTLX2071D327 Optical Transceiver FTLX2071D333 | ⑧ HPRU Mounting Bracket I | ⑨ HPRU Mounting Bracket II | |
|  |  |  | |
| ⑩ AC Power Lead 2.5m | | | |
|  | | | |
| ⑪ Ground Wire 2m | | | |
|  | | | |

Wall Installation (Back on the Wall)

1. Attach and fasten the handle to the side of H2RU with screws M6×14 using T5 Wrench.

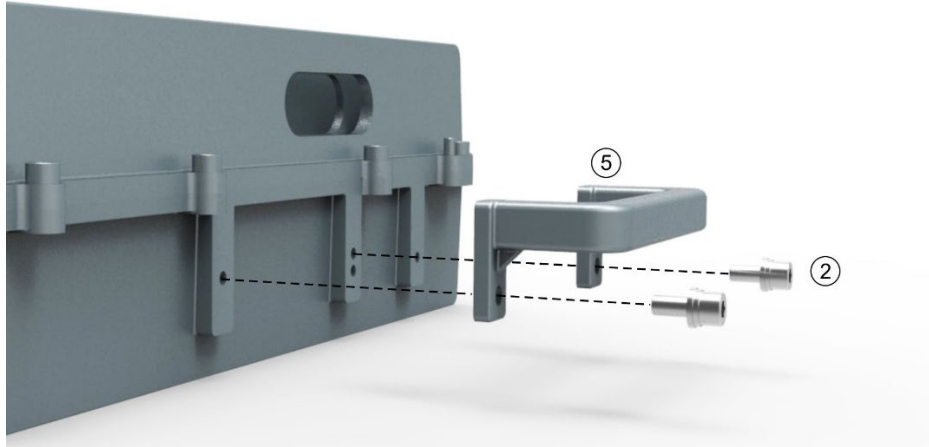

2. Attach and fasten the Bracket I to the back of H2RU with screws M6×14 using T5 Wrench.

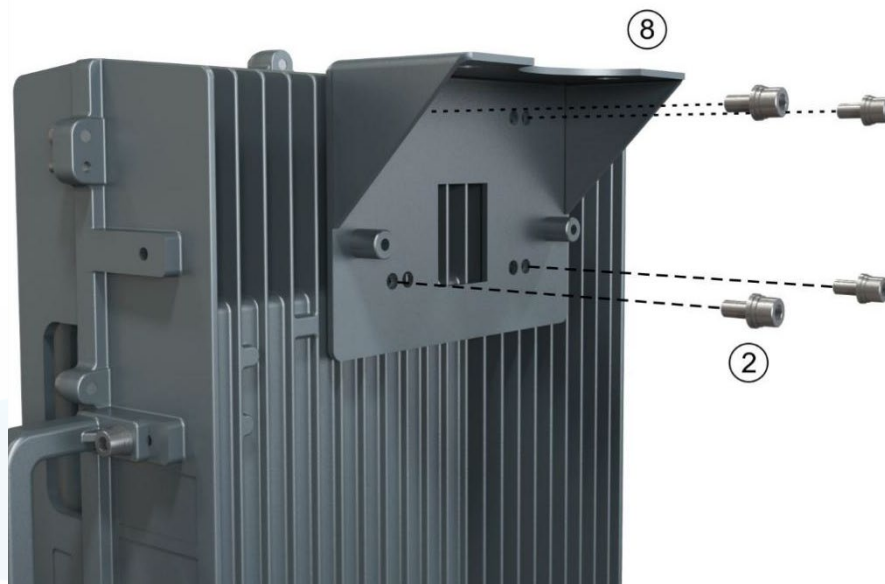

3. Mark the position of the drilling holes in the mounting Bracket II. Note: R=13mm.

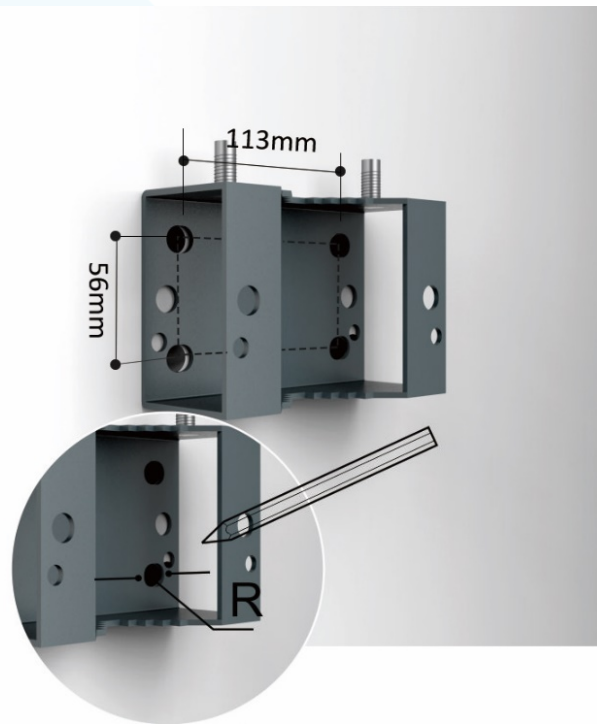

4. Drill 4 holes at the marked positions. Note: H=70mm



5. Attach the dowels, expansion screws or the like and fasten the Bracket II to the wall.

Contact us today:

www.sunwave.com

cf_support@sunwave.com

Tips: use Bracket II as a reference to control each devices' separation distance before hanging and locking H2RU up.

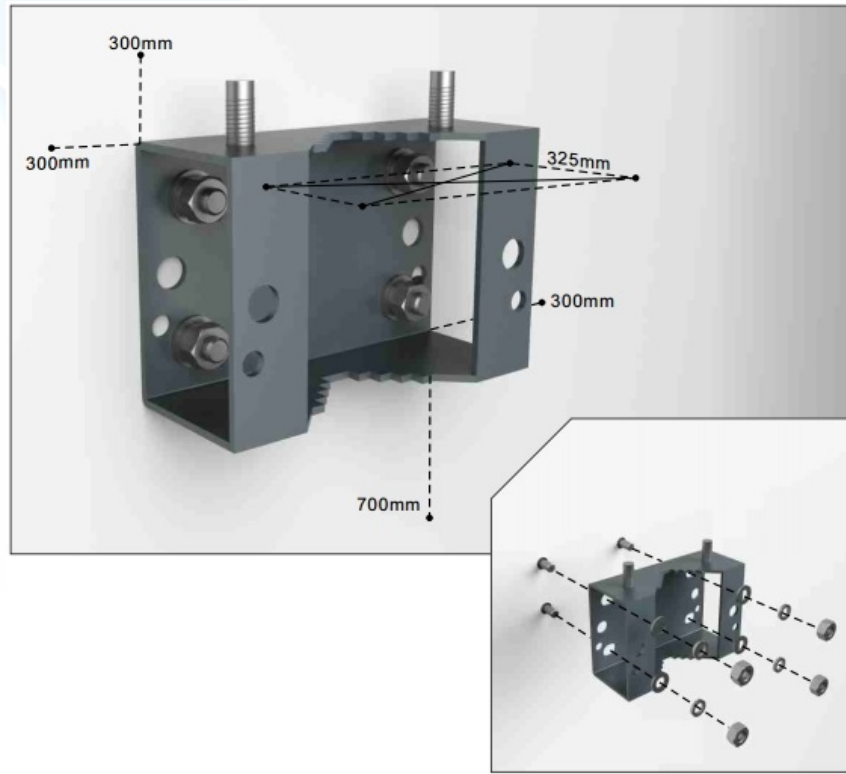

6. Hang the H2RU on the mounting bracket II and fasten with nuts M10.

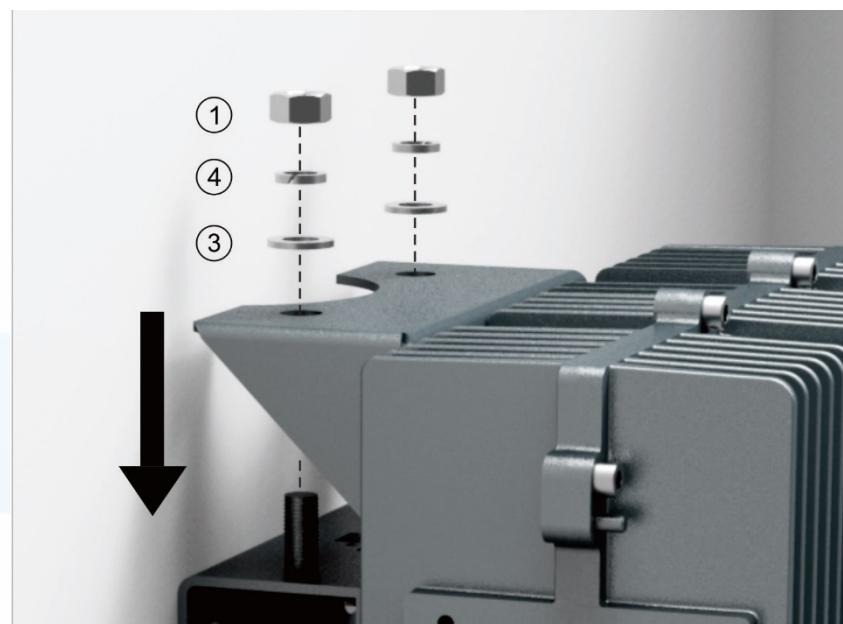

7. Fasten the Bracket I and II with screws M6×14.



8. Connect and lock the power cable at the H2RU rear side



9. Connect and screw the ground cable at the H2RU's left side

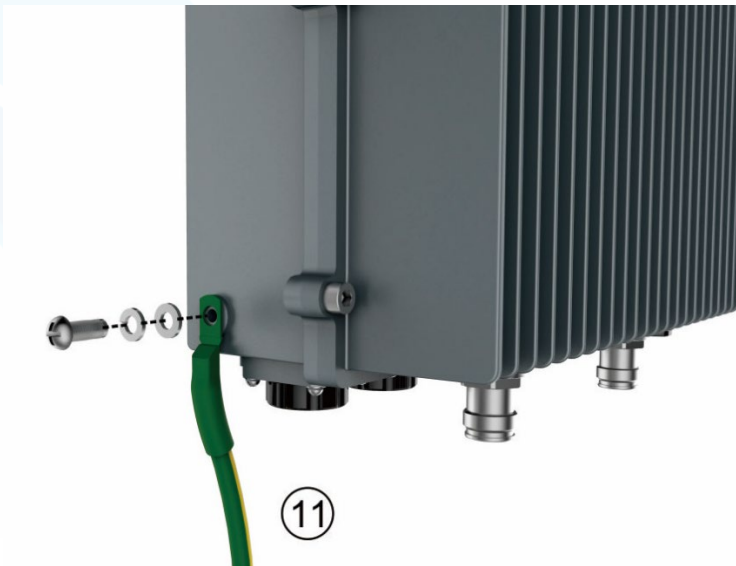

Wall Installation (Side on the Wall)

1. Attach and fasten the handle to the side of H2RU with screws M6×14 using T5 Wrench.

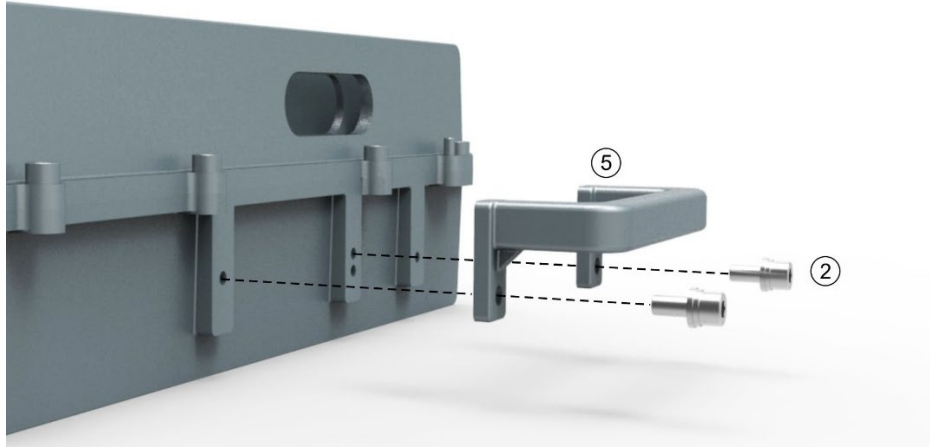

2. Attach and fasten the Bracket I to the left side of H2RU with screws M6×14 using T5 Wrench.

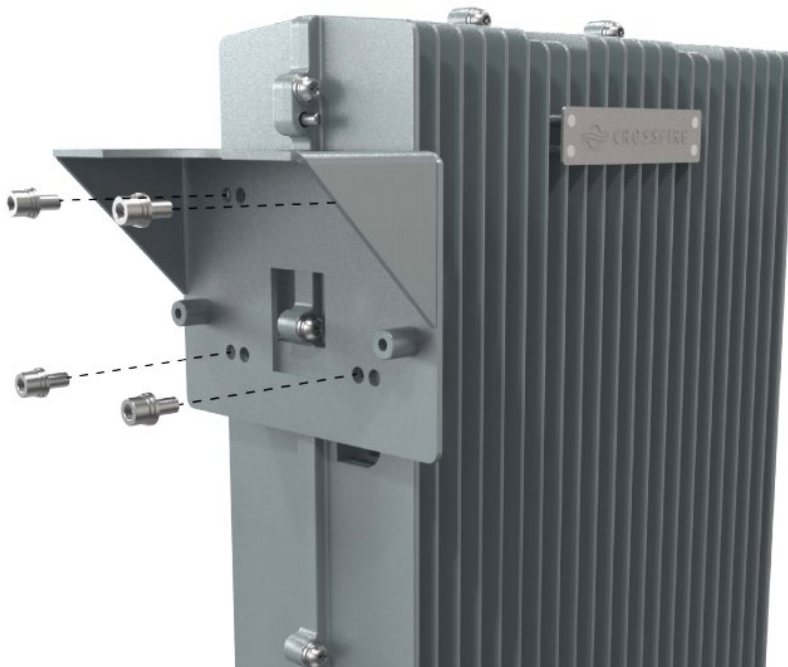

3. Mark the position of the drilling holes in the mounting Bracket II. Note: R=13mm.

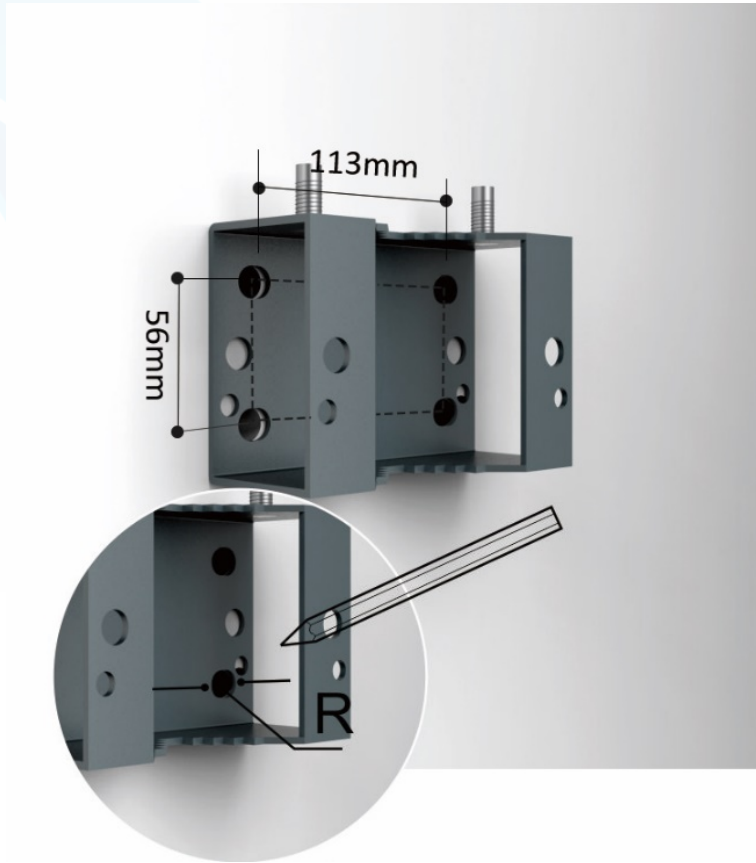

4. Drill 4 holes at the marked positions. Note: H=70mm.



5. Attach the dowels, expansion screws or the like and fasten the Bracket II to the wall.

Tips: use Bracket II as a reference to control each devices' separation distance before hanging and locking H2RU up.

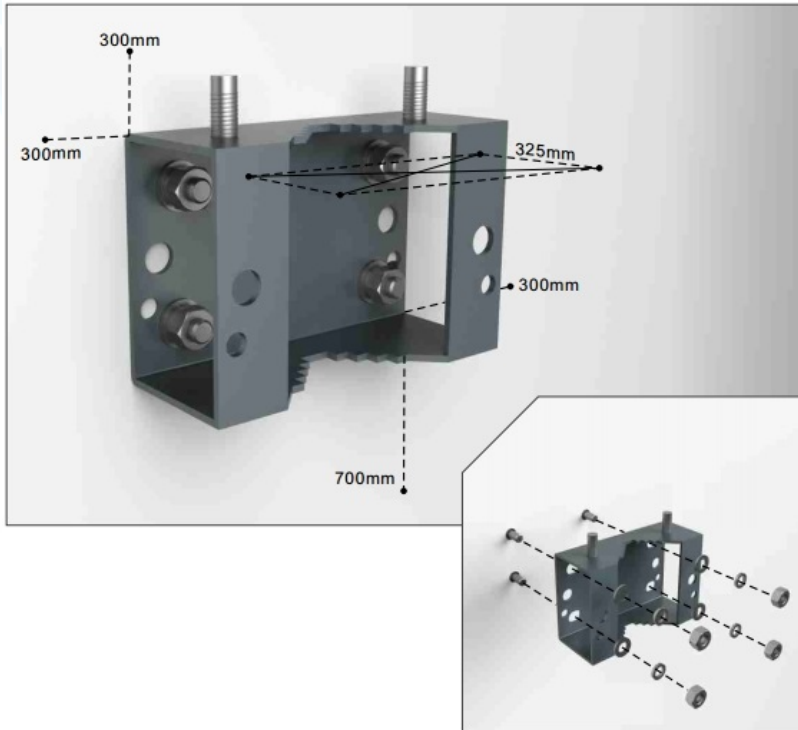

6. Hang the H2RU on the mounting bracket II and fasten with nuts M10.



7. Fasten the Bracket I and II with screws M6×14.

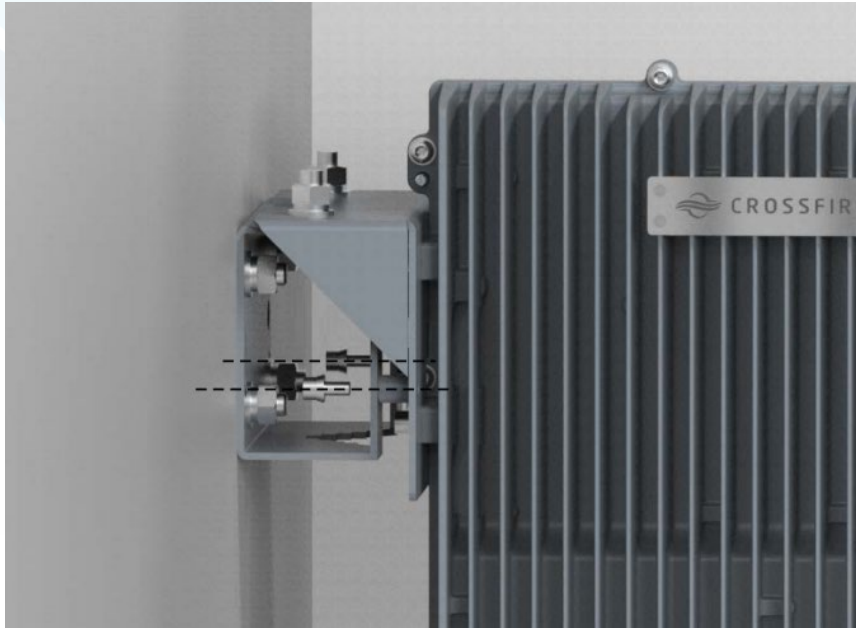

8. Connect and lock the power cable at the H2RU rear side



9. Connect and screw the ground cable at the H2RU left side.



HIGH POWER

43dBm Dual Band
Digital Radio

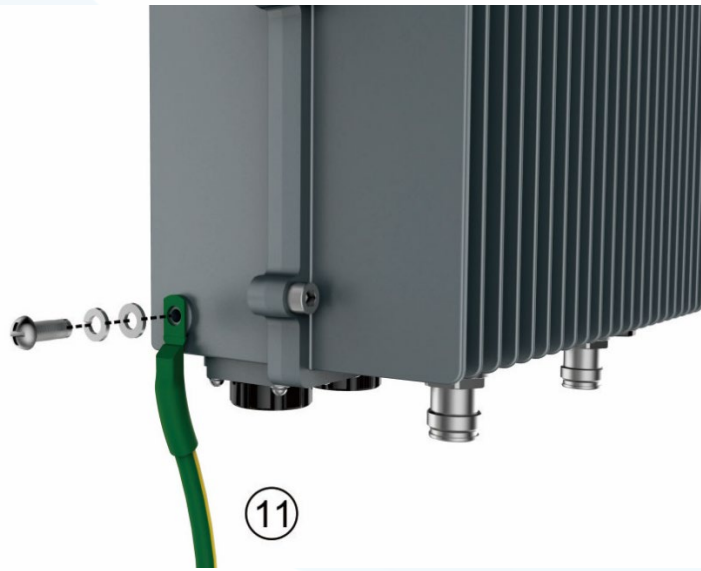

Contact us today:
www.sunwave.com
cf_support@sunwave.com



Pole Installation

1. Install the handle and Bracket I to the back of H2RU.
2. Install the bracket II and Bracket III to the pole.
3. Hang the H2RU on the mounting bracket and fasten with nuts M10.
4. Connect the ground cable and power cable.

 Extra accessories are required for pole installation and purchased separately.

Note: The diameter of Pole shall not be over 110mm or less than 55mm.

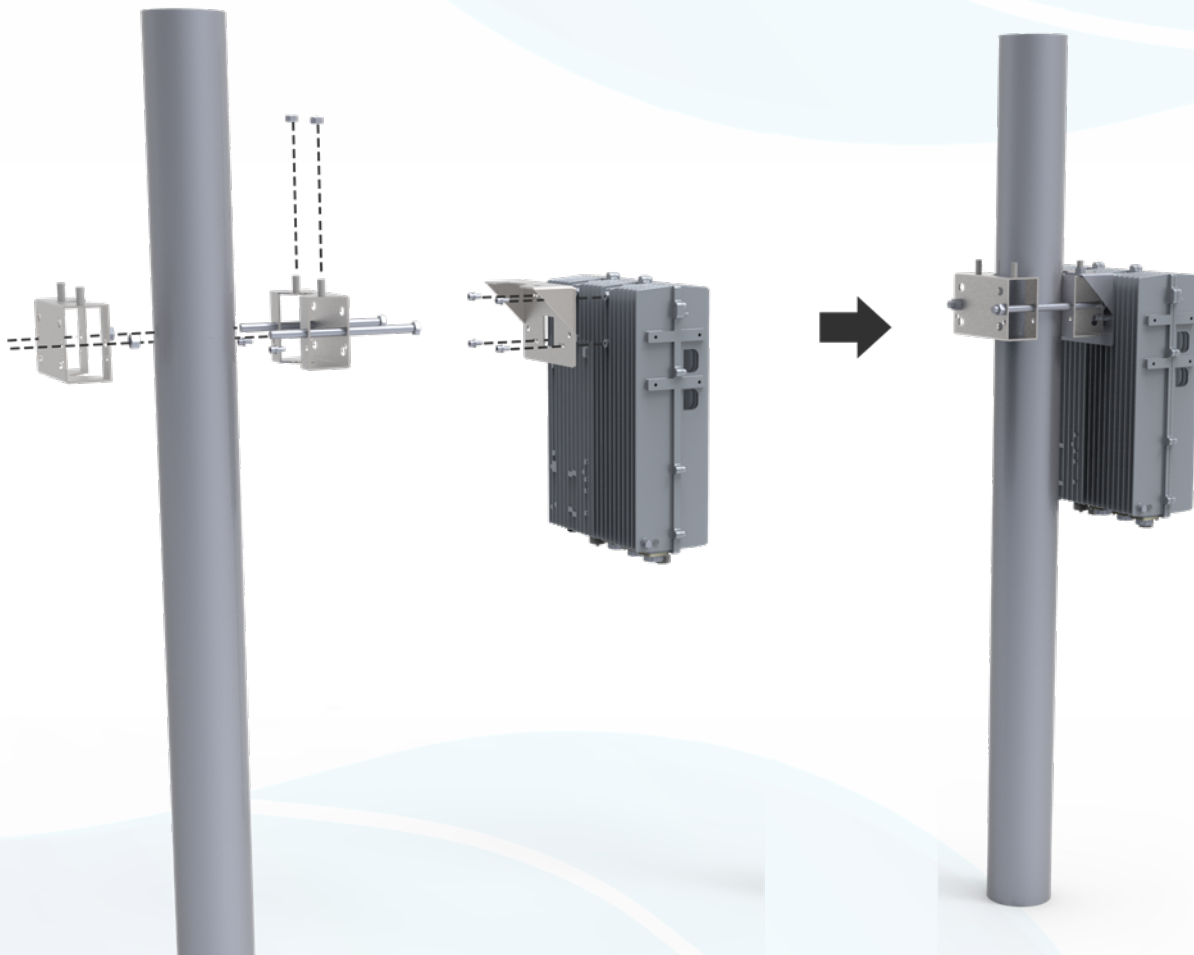

H2RU Mounting Dimension Spacing

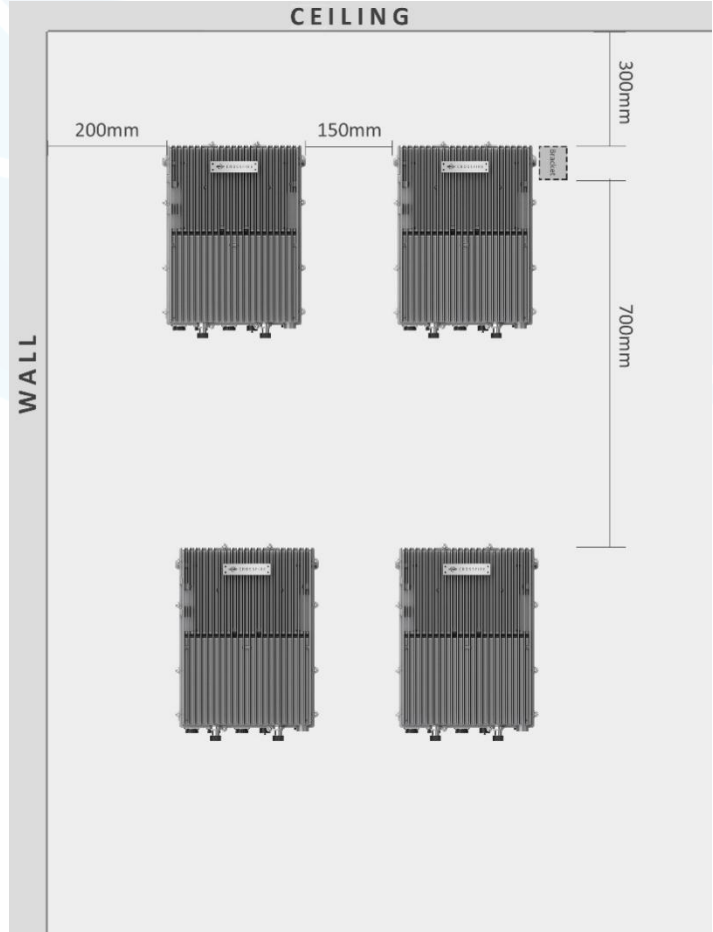
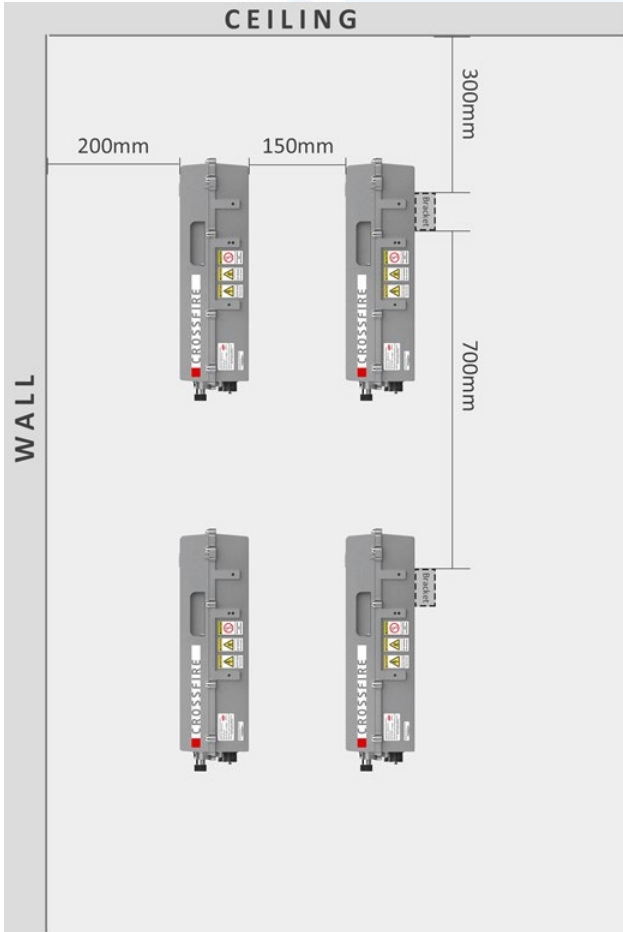

Optical Connection

Optical Transceiver Module

Single Port Bidirectional SFP Transceiver

The Figure below shows a pair of single port Bidirectional SFP transceivers. For devices optical connection, the transceivers of two sides must be paired - the wavelength of one side is 1271nm, and the wavelength of another side is 1331nm. Otherwise, it will fail the connection. All lower-level devices under this port won't be working in the system.

All the optical ports of all type devices have triangle LED indicators pointing to each port, which represent the synchronization status of the upper and lower optical modules. The indicator turns to green when optical modules are plugged in ports and synchronized. When the connection is down, or there is no optical module in port, the indicator remains red.



 The single port SFP modules have to be used in pairs.

Dual Port SFP Transceiver

The optical connector unit includes an optical module and optical fibre. The Figure below shows that when using a dual-port SFP module, the optical transmitter and optical receiver should correspond to each other. In other words, the optical transmitter of optical module A should correspond to the optical receiver of optical module B, and the receiver of A should correspond to the transmitter of B. The optical receiver and transmitter terminals of the optical module can be determined by the triangular mark on the optical module. The triangular mark in the yellow box and the red and blue lines indicate the optical fibre connections.

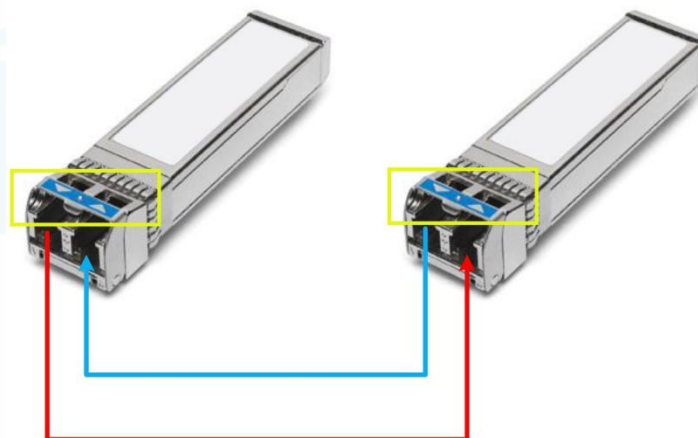

Optical Indicator

Each pair (2) of optical module cages has four LED indicator arrows. The two on the left are green, and the two on the right are red, as shown in Figure below. The indicator arrows represent the synchronization status of the upper and lower optical modules. When a pair of optical modules are synchronized (both uplink and downlink), the indicators turn green as shown in the right pair of indicators in Figure below. When the optical module is unplugged or not synchronized, the indicators are red, as shown in the left pair of indicators. Check whether both indicators turn green after connecting one pair of optical modules. If the indicators are red, the terminal has not synchronized.

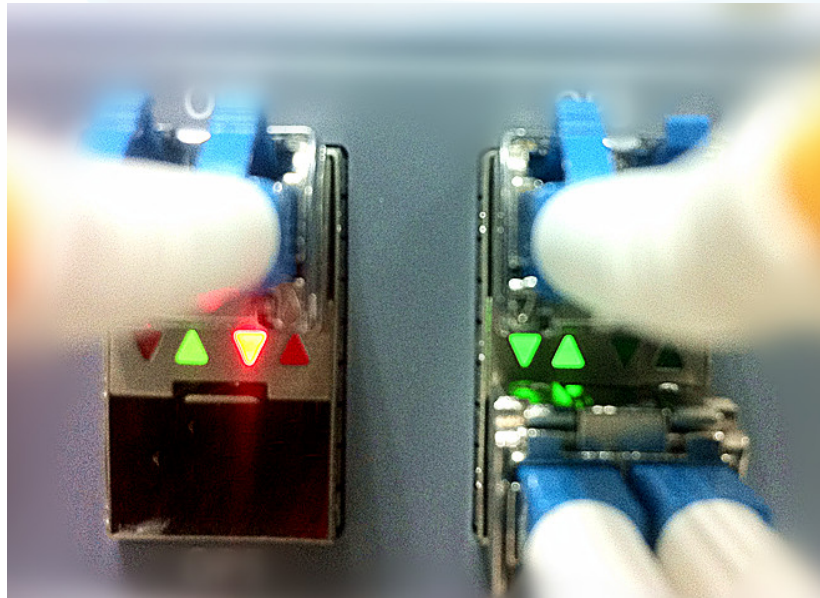

A2 Optical Port Description

Obtain the required lengths of optical fibers for all the optical connections and connect the fibers on the front panel of Access Unit.

The interface type of SFP transceivers is an LC connector.

It is important to label all ports on the fiber distribution panel correctly.

It is recommended to include additional length/slack in the optical fiber to allow future re-configurations without requiring additional splices.

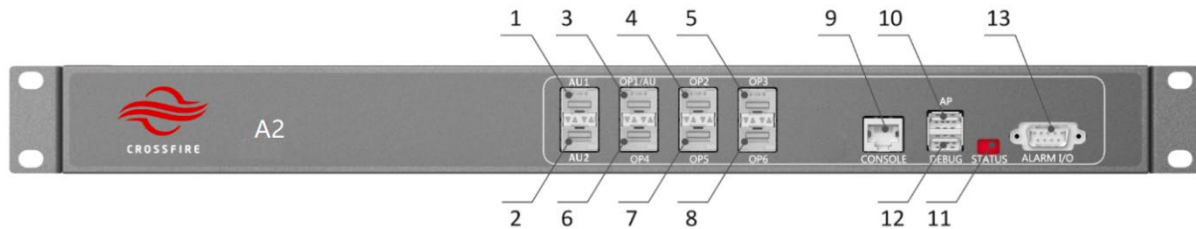

A2 Front Panel Interfaces

| SN | Interface Name | Description |
|----|----------------|--|
| 1 | AU1 | Connects Slave A2 1 |
| 2 | AU2 | Connects Slave A2 2 |
| 3 | OP1/AU | For Master A2: connects EU/RU For Slave A2: connects Master A2 |
| 4 | OP2 | Connects EU/RU |
| 5 | OP3 | Connects EU/RU |
| 6 | OP4 | Connects EU/RU |
| 7 | OP5 | Connects EU/RU |
| 8 | OP6 | Connects EU/RU |
| 9 | CONSOLE | Connects OMC or local PC through CAT-5 for local and remote monitoring |
| 10 | AP | Connects WLAN network adapters for monitoring device through Wi-Fi |
| 11 | STATUS | Indicates device operating status |
| 12 | DEBUG | Connects local debugging PC through a USB connection |
| 13 | ALARM I/O | Connects external environment alarm interface for environment monitoring |

E2-O Optical Port Description

Obtain the required lengths of optical fibers for all the optical connections and connect the fibers on the front panel of the Expansion Unit.

The interface type of SFP transceivers is an LC connector.

Contact us today:

www.sunwave.com

cf_support@sunwave.com



CROSSFIRE

HIGH POWER

43dBm Dual Band
Digital Radio

It is important to label all ports on the fiber distribution panel correctly.

It is recommended to include additional length/slack in the optical fiber to allow future re-configurations without requiring additional splices.

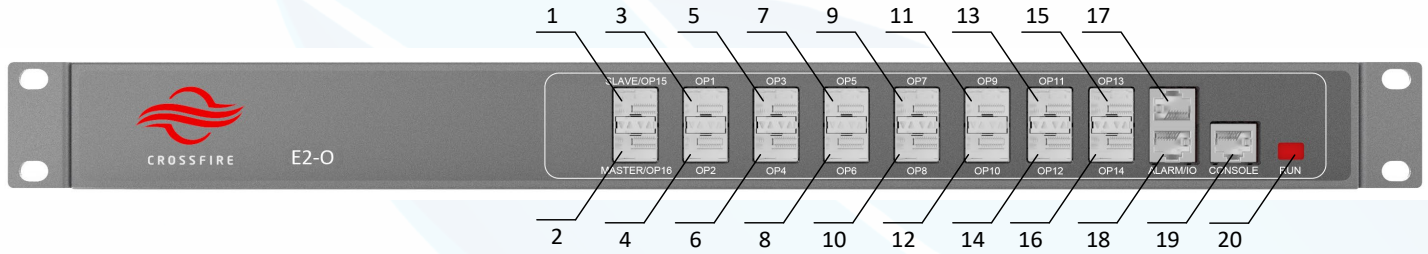

E2 Front Panel Interfaces

| SN | Interface Name | Description |
|----|----------------|--|
| 1 | SLAVE/OP15 | Connection for Master A2/EU at the next higher level |
| 2 | MASTER/OP16 | Connection for EU at the next lower level |
| 3 | OP1 | Connection for RU |
| 4 | OP2 | Connection for RU |
| 5 | OP3 | Connection for RU |
| 6 | OP4 | Connection for RU |
| 7 | OP5 | Connection for RU |
| 8 | OP6 | Connection for RU |
| 9 | OP7 | Connection for RU |
| 10 | OP8 | Connection for RU |
| 11 | OP9 | Connection for RU |
| 12 | OP10 | Connection for RU |
| 13 | OP11 | Connection for RU |
| 14 | OP12 | Connection for RU |
| 15 | OP13 | Connection for RU |
| 16 | OP14 | Connection for RU |
| 17 | Alarm | Alarm IN |
| 18 | Alarm | Alarm OUT |
| 19 | CONSOLE | Connection for local PC through CAT-5 for local monitoring |
| 20 | STATUS | Indicates device operating status |

Contact us today:
www.sunwave.com
cf_support@sunwave.com



RU Optical Port Description

Obtain the required lengths of optical fibers for all the optical connections and connect the fibers on the front panel of Remote Unit.

The interface type of SFP transceivers is an LC connector.

It is important to label all ports on the fiber distribution panel correctly.

It is recommended to include additional length/slack in the optical fiber to allow future re-configurations without requiring additional splices.

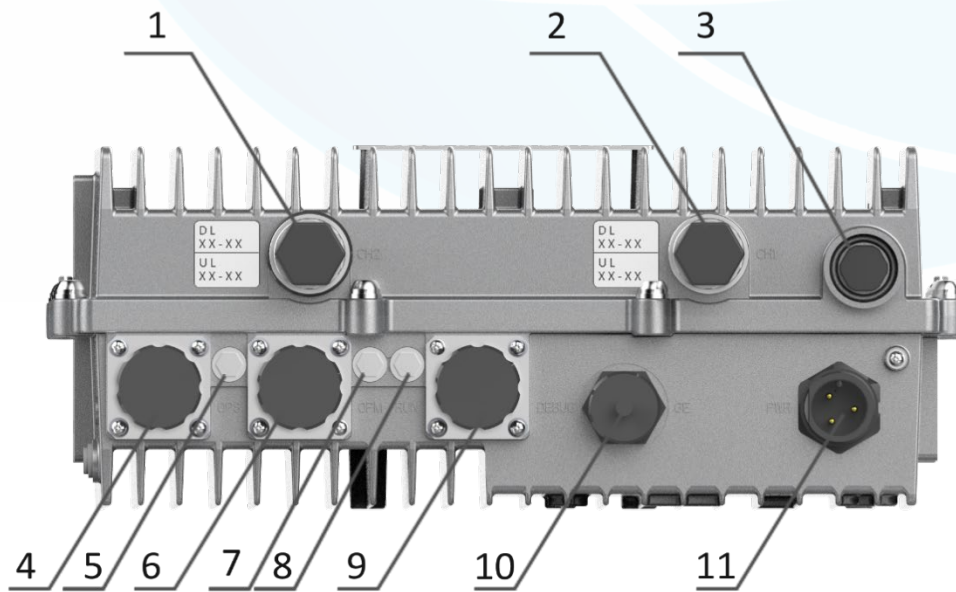

RU Front Panel Interfaces

| SN | Interface Name | Description |
|----|-------------------|--|
| 1 | CH2 | PA 2 Module Interface, 4.3-10 female Connector |
| 2 | CH1 | PA 1 Module Interface, 4.3-10 female Connector |
| 3 | Air Pressure hole | Make the pressure balance |
| 4 | Slave OP | Connection for EU or RU at the next higher level |
| 5 | Slave | Indicates Slave OP port operating status |
| 6 | MASTER OP | Connection for RU at the next lower level |
| 7 | Master | Indicates Master OP port operating status |
| 8 | RUN | Indicates device operating status |
| 9 | DEBUG | Connection for local PC through CAT-5 for local monitoring |
| 10 | GE | Reserved |
| 11 | PWR | Electrical Power Line Interface |



FCC Statement:

Any Changes or modifications not expressly approved by the party responsible for compliance could void the user's authority to operate the equipment.

This device complies with part 15 of the FCC Rules. Operation is subject to the following two conditions:

- (1) This device may not cause harmful interference, and
- (2) This device must accept any interference received, including interference that may cause undesired operation.

FCC Radiation Exposure Statement:

This equipment complies with FCC radiation exposure limits set forth for an uncontrolled environment .

This transmitter must not be co-located or operating in conjunction with any other antenna or transmitter. This equipment should be installed and operated with minimum distance 400 cm between the radiator & your body.

ISED RSS Warning:

This device complies with Innovation, Science and Economic Development Canada licence-exempt RSS standard(s). Operation is subject to the following two conditions: (1) this device may not cause interference, and (2) this device must accept any interference, including interference that may cause undesired operation of the device.

Le présent appareil est conforme aux CNR d'ISED applicables aux appareils radio exempts de licence. L'exploitation est autorisée aux deux conditions suivantes:

- (1) l'appareil ne doit pas produire de brouillage, et
- (2) l'utilisateur de l'appareil doit accepter tout brouillage radioélectrique subi, même si le brouillage est susceptible d'en compromettre le fonctionnement.

ISED RF exposure statement:

This equipment complies with ISED radiation exposure limits set forth for an uncontrolled environment. This equipment should be installed and operated with minimum distance 400 cm between the radiator & your body. This transmitter must not be co-located or operating in conjunction with any other antenna or transmitter.

Le rayonnement de la classe b respecte ISED fixaient un environnement non contrôlés. Installation et mise en œuvre de ce matériel devrait avec échangeur distance minimale entre 400 cm ton corps. Lanceurs ou ne peuvent pas coexister cette antenne ou capteurs avec d'autres.

Contact us today:

www.sunwave.com
cf_support@sunwave.com



CROSSFIRE

HIGH POWER

43dBm Dual Band
Digital Radio

WARNING. This is **NOT** a **CONSUMER** device. It is designed for installation by **FCC LICENSEES** and **QUALIFIED INSTALLERS**. You **MUST** have an **FCC LICENSE** or express consent of an FCC Licensee to operate this device. Unauthorized use may result in significant forfeiture penalties, including penalties in excess of \$100,000 for each continuing violation.

WARNING: This is **NOT** a **CONSUMER** device. It is designed for installation by an installer approved by an ISED licensee. You **MUST** have an **ISED LICENCE** or the express consent of an ISED licensee to operate this device.