



7.2.3.1 Measurement Record:

Downlink: 1930MHz to 1995MHz (LTE Mode)

1. 5MHz bandwidth

1.1 one signal input (Level=0dBm, modulation= LTE(64QAM),Frequency=1932.5MHz)—Lower Edge

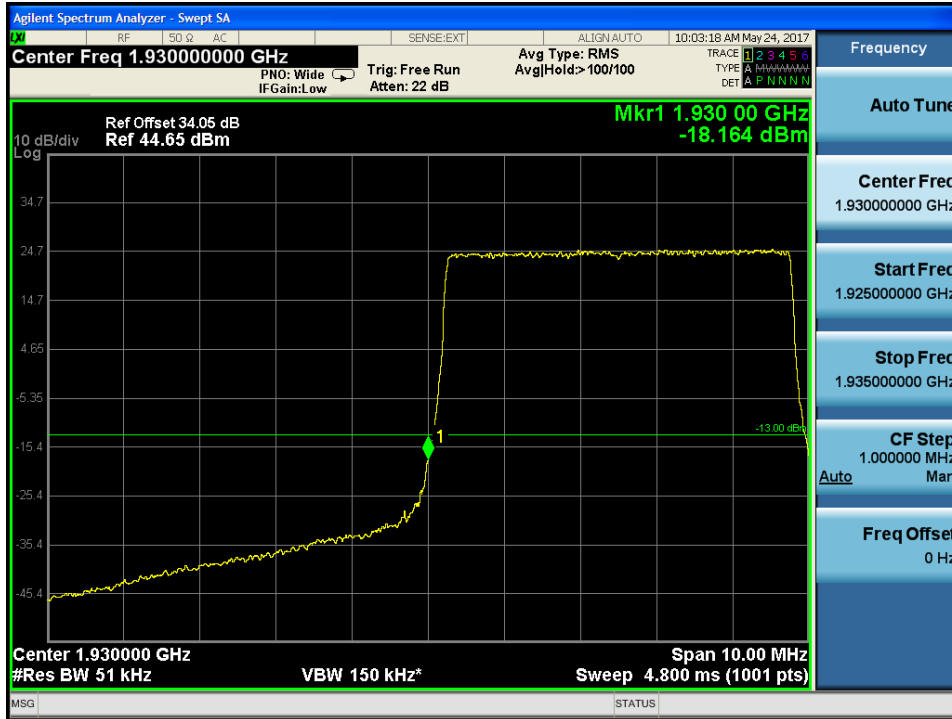

1.2 one signal input (Level=0dBm, modulation= LTE(64QAM),Frequency=1992.5MHz)—Upper Edge





1.3 two signal input (Level=0dBm, modulation=LTE(64QAM), Frequency1=1932.5MHz, Frequency2=1937.5MHz) —Lower Edge

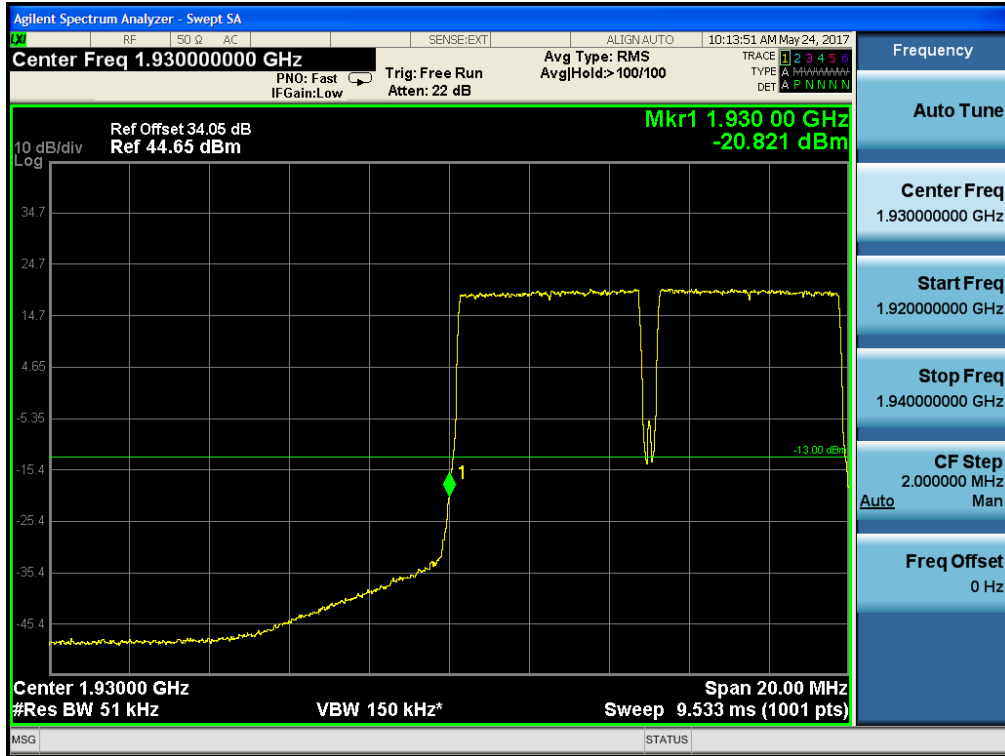

1.4 two signal input(Level=0dBm, modulation=LTE(64QAM), Frequency1=1992.5MHz, Frequency2=1987.5MHz) —Upper Edge





2. 20MHz bandwidth

2.1 one signal input(Level=0dBm, modulation=LTE(64QAM),Frequency=1940MHz) —Lower Edge

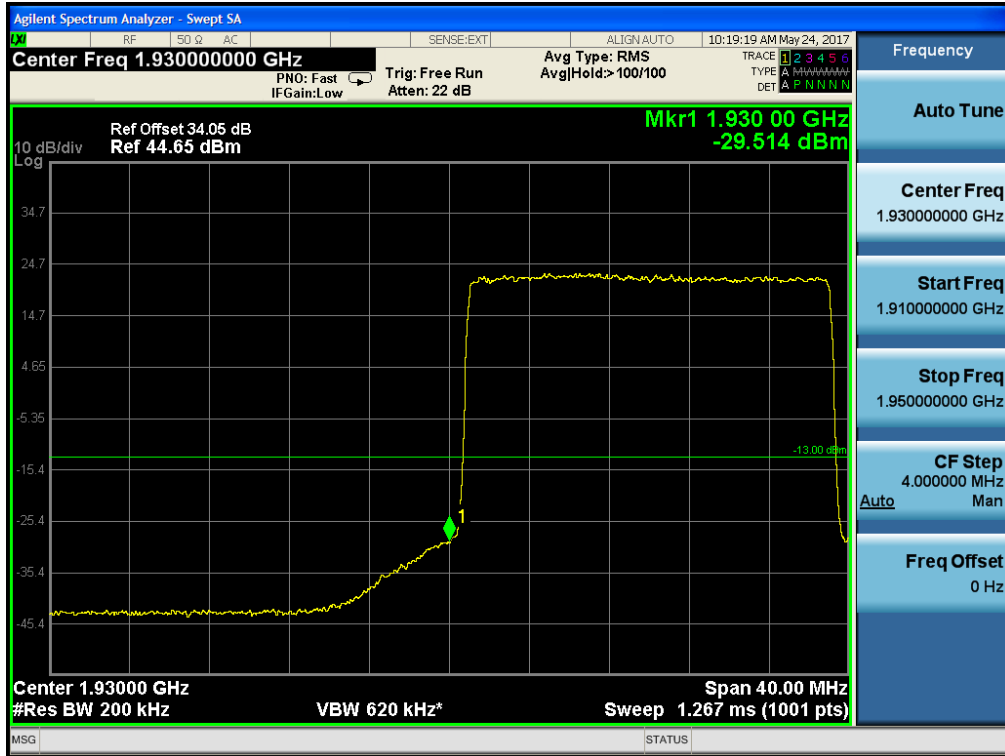

2.2 one signal input(Level=0dBm, modulation=LTE(64QAM),Frequency=1985MHz) —Upper Edge





2.3 two signal input (Level=0dBm, modulation=LTE(64QAM), Frequency1=1940MHz, Frequency2=1960MHz)—Lower Edge

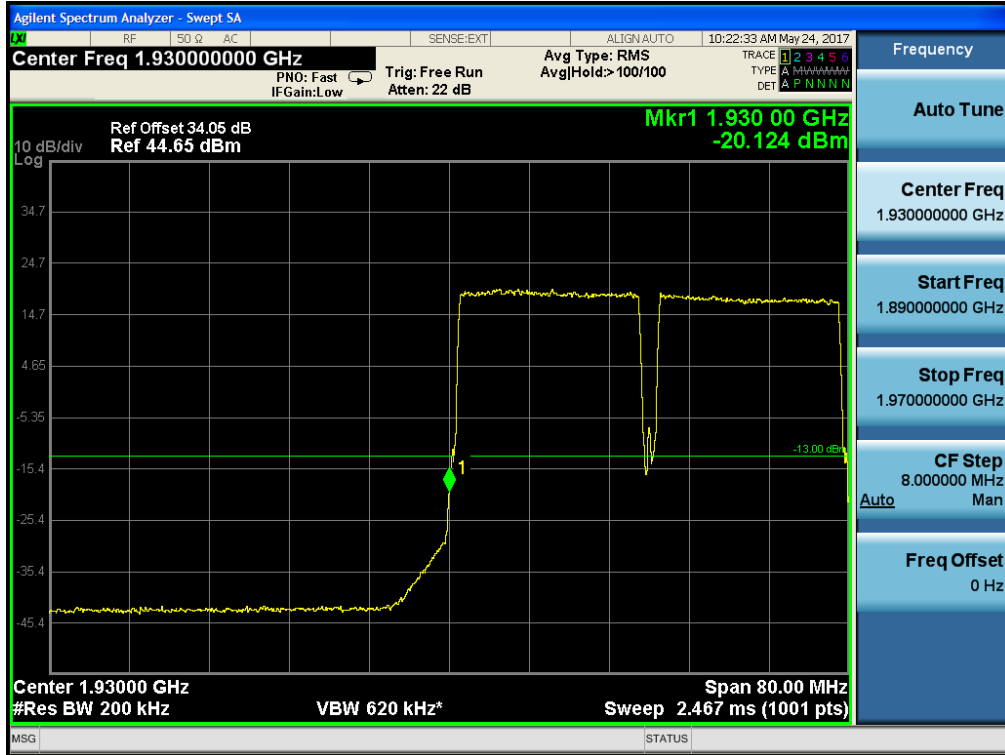

2.4 Two signal input (Level=0dBm, modulation= LTE (64QAM), Frequency1=1985MHz, Frequency2=1965MHz)—Upper Edge





Downlink: 1930MHz to 1995MHz (WCDMA Mode)

1. one signal input(Level=0dBm, modulation=WCDMA,Frequency=1932.4MHz) —Lower Edge

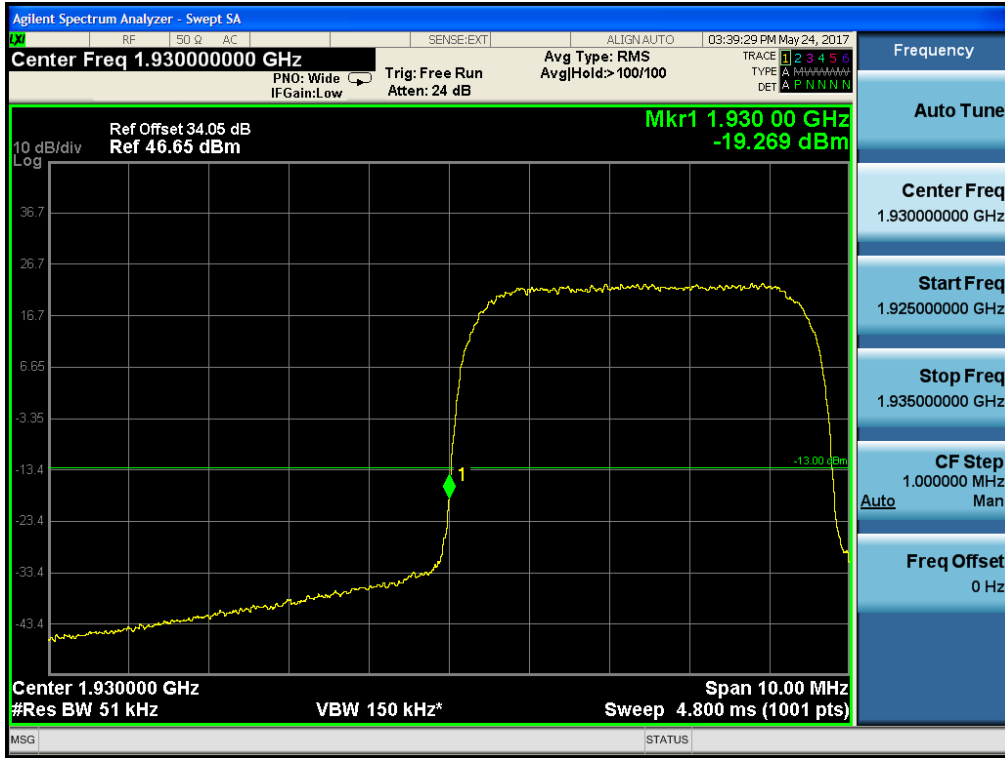

2. one signal input(Level=0dBm, modulation=WCDMA,Frequency=1992.6MHz) —Upper Edge





3. two signal input(Level=0dBm, modulation=WCDMA,Frequency1=1932.4MHz, Frequency2=1937.4MHz)
—Lower Edge

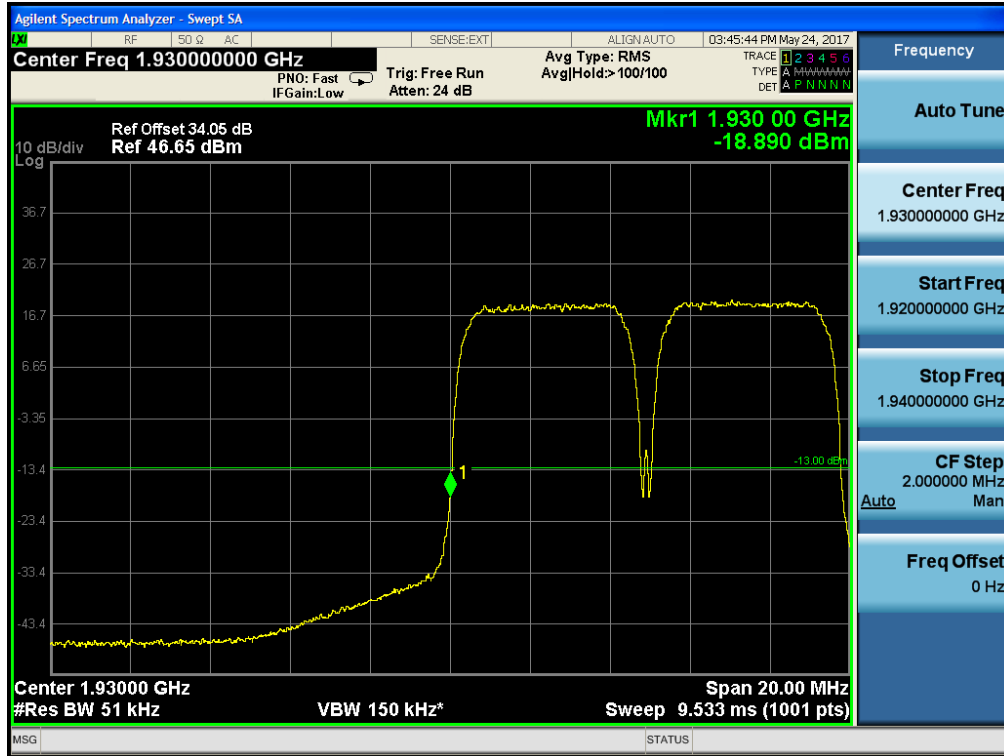

4. two signal input(Level=0dBm, modulation=WCDMA,Frequency1=1992.6MHz, Frequency2=1987.6MHz)
—Upper Edge

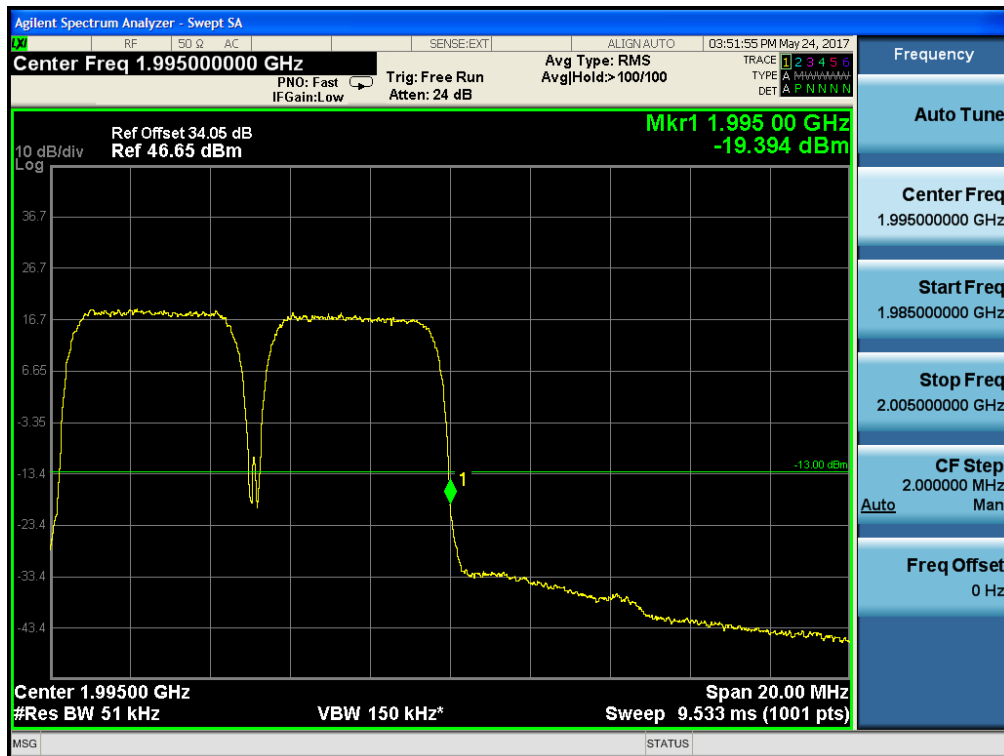



Downlink: 1930MHz to 1995MHz (CDMA Mode)

1. one signal input(Level=0dBm, modulation=CDMA, Frequency=1931.25MHz) —Lower Edge

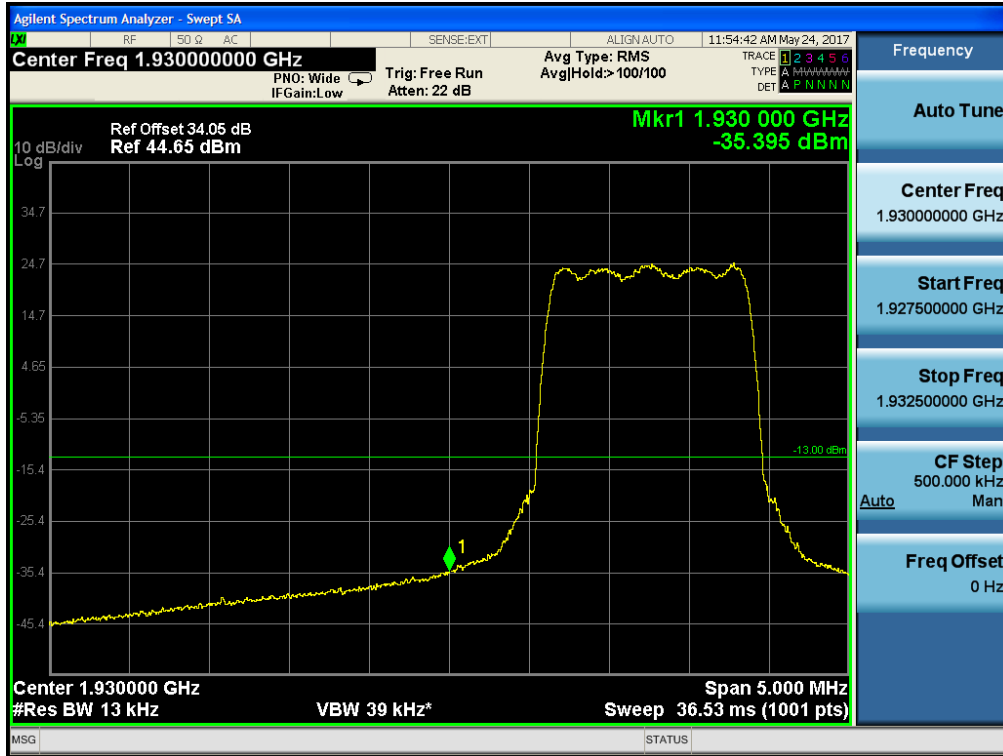

2. one signal input(Level=0dBm, modulation=CDMA, Frequency=1993.75MHz) —Upper Edge

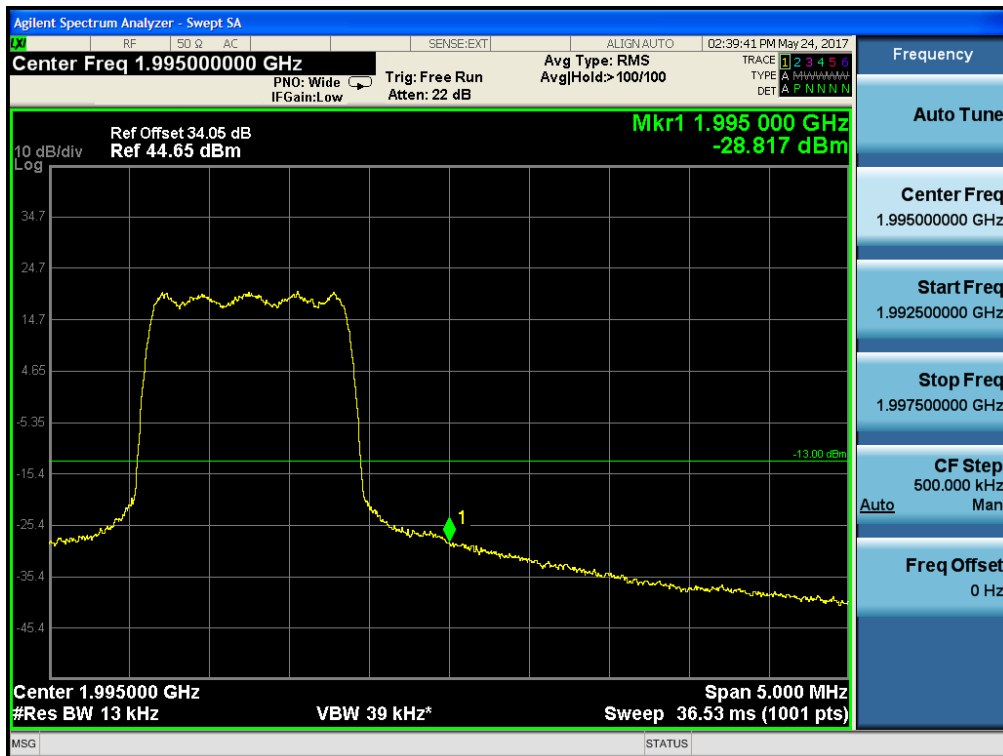



SGS-CSTC Standards Technical Services Ltd. Shenzhen Branch

Report No.: SZEM170600640811

Page: 53 of 90

3. two signal input(Level=0dBm, modulation=CDMA,Frequency1=1931.25MHz, Frequency2=1936.25MHz)
—Lower Edge

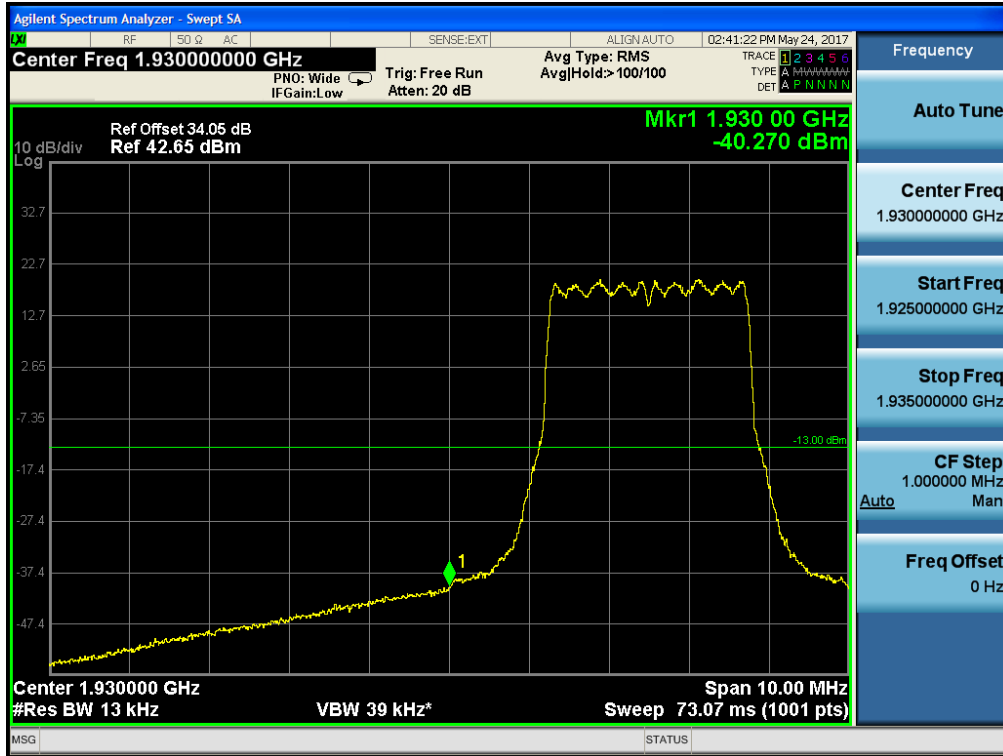

4. two signal input(Level=0dBm, modulation=CDMA,Frequency1=1993.75MHz, Frequency2=1988.75MHz)
—Upper Edge

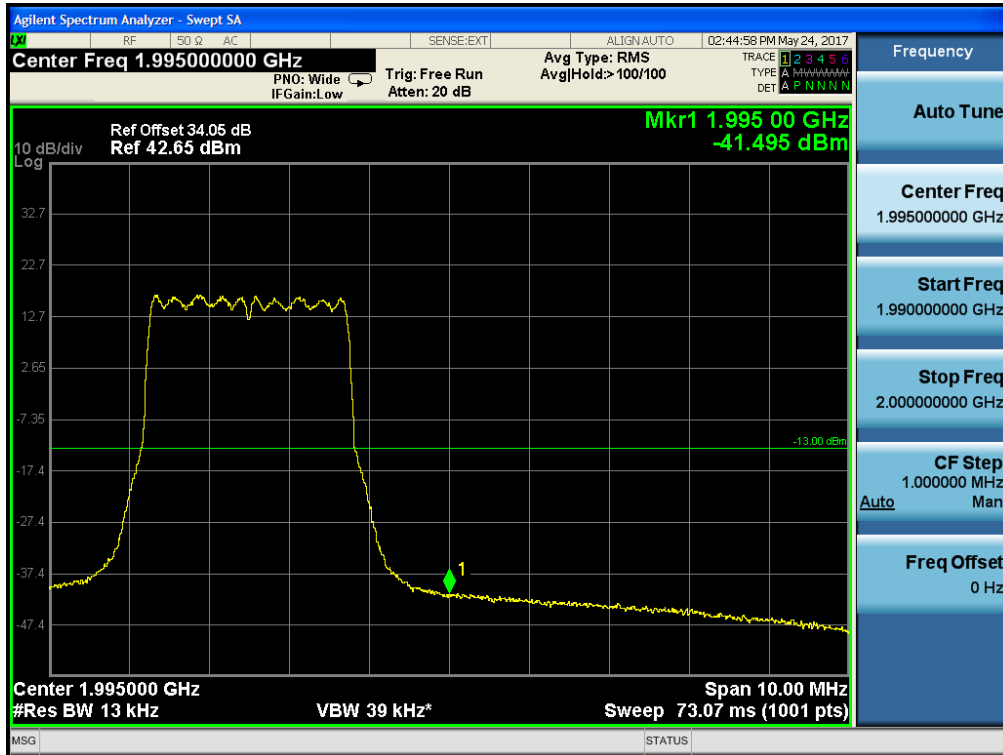

7.2.4 Radiated Spurious Emissions

- Test Requirement: FCC part 24
The limit is = -13 dBm.
- Test Method: KDB 935210 D05 Indus Booster Basic Meas v01r01
- EUT Operation:
Status: Drive the EUT to maximum output power.
Conditions: Normal conditions
Application: Enclosure
- Test Configuration:

30MHz to 1GHz emissions:

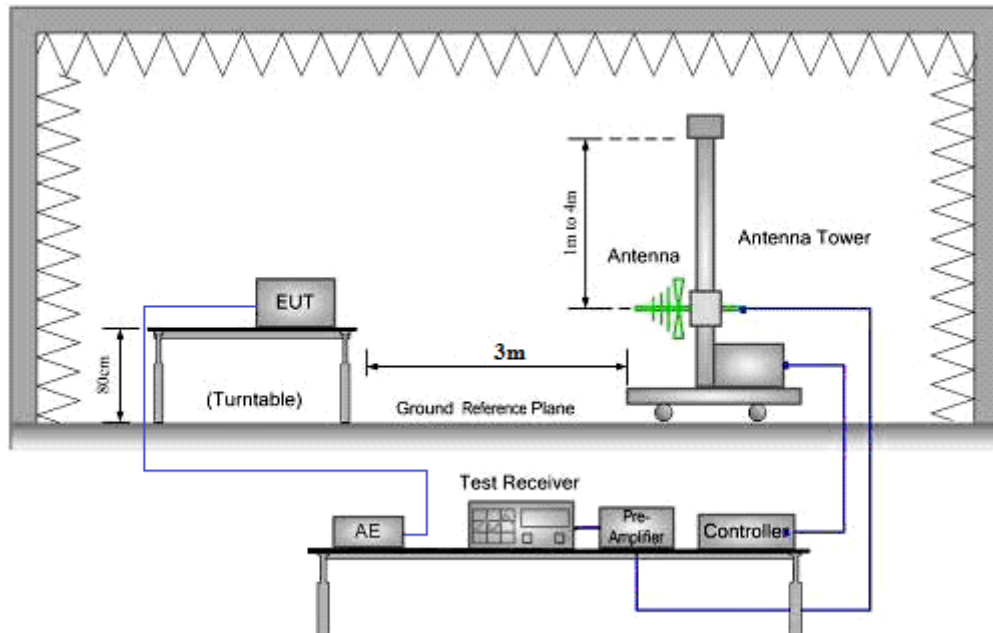

1GHz to 40GHz emissions:

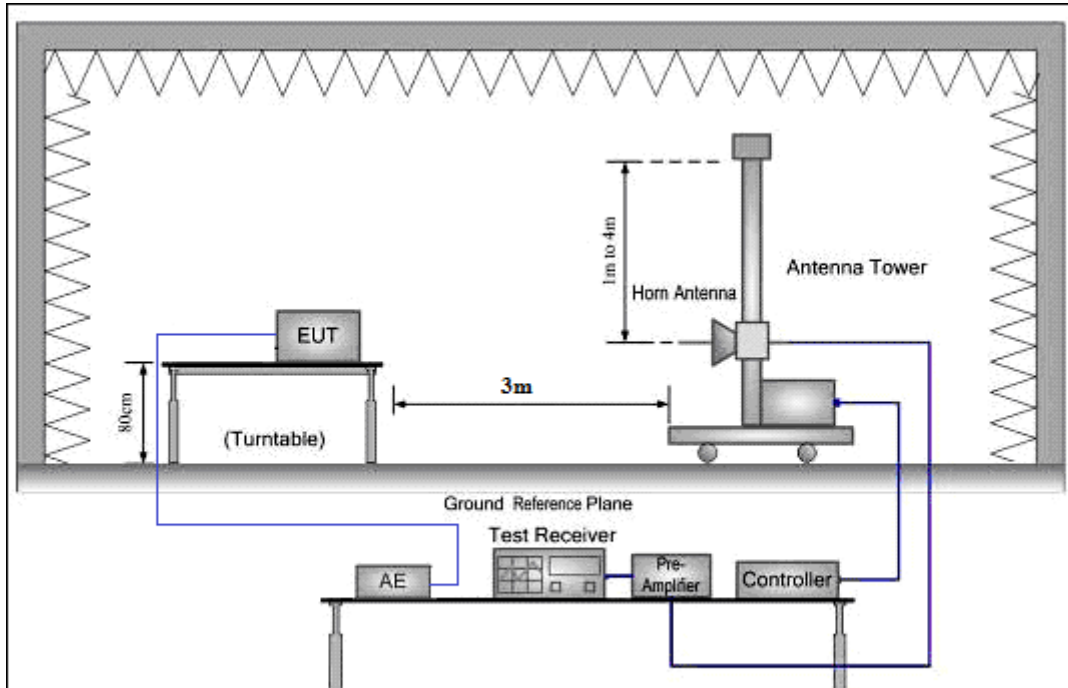

Test Procedure:

1. Test the background noise level with all the test facilities;
2. Keep one transmitting path, all other connectors shall be connected by normal power or RF leads;
3. Select the suitable RF notch filter to avoid the test receiver or spectrum analyzer produce unwanted spurious emissions;
4. Keep the EUT continuously transmitting in max power;
5. Read the radiated emissions of the EUT enclosure.

Radiated Emissions Test Procedure:

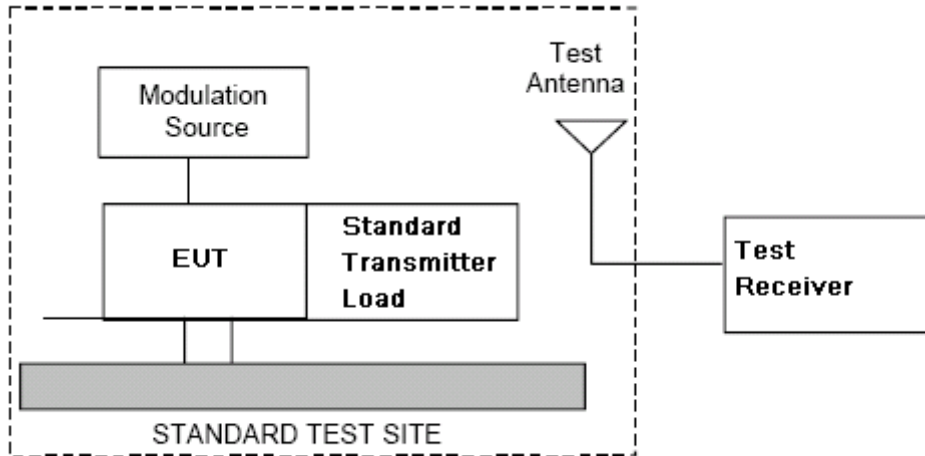

- a) Connect the equipment as illustrated.
- b) Adjust the spectrum analyzer for the following settings:
 - 1) Resolution Bandwidth = 100 kHz for spurious emissions below 1 GHz, and 1 MHz for spurious emissions above 1GHz.
 - 2) Video Bandwidth = 300 kHz for spurious emissions below 1 GHz, and 3 MHz for spurious emissions above 1 GHz.
 - 3) Sweep Speed slow enough to maintain measurement calibration.
 - 4) Detector Mode = Positive Peak.
- c) Place the transmitter to be tested on the turntable in the standard test site, The transmitter is transmitting into a no radiating load that is placed on the turntable. The RF cable to this load should be of minimum length.
- d) Measurements shall be made from 30MHz to 10 times of fundamental carrier, except for the region close to the carrier equal to \pm the carrier bandwidth.
- e) Key the transmitter without modulation or normal modulation base the standard.
- f) For each spurious frequency, raise and lower the test antenna from 1 m to 4 m to obtain a maximum reading on the spectrum analyzer with the test antenna at horizontal polarity. Then the turntable should be rotated 360° to determine the maximum reading. Repeat this procedure to obtain the highest possible reading. Record this maximum reading.
- g) Repeat step f) for each spurious frequency with the test antenna polarized vertically.

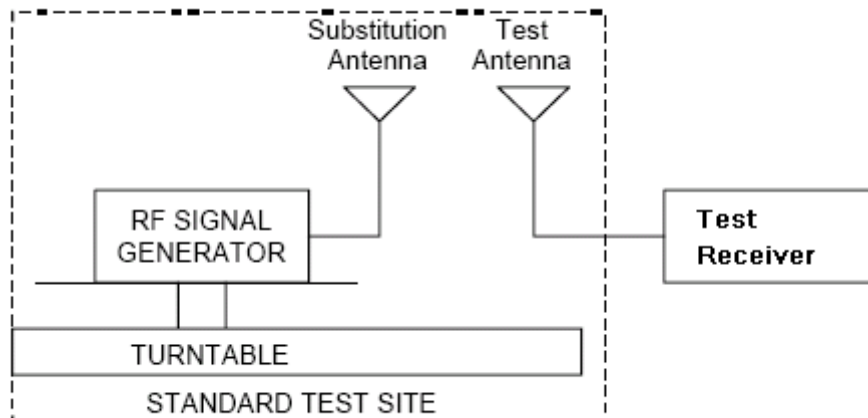



- h) Reconnect the equipment as illustrated.
- i) Keep the spectrum analyzer adjusted as in step b).
- j) Remove the transmitter and replace it with a substitution antenna (the antenna should be half-wavelength for each frequency involved). The center of the substitution antenna should be approximately at the same location as the center of the transmitter. At the lower frequencies, where the substitution antenna is very long, this will be impossible to achieve when the antenna is polarized vertically. In such case the lower end of the antenna should be 0.3 m above the ground.
- k) Feed the substitution antenna at the transmitter end with a signal generator connected to the antenna by means of a non-radiating cable. With the antennas at both ends horizontally polarized, and with the signal generator tuned to a particular spurious frequency, raise and lower the test antenna to obtain a maximum reading at the spectrum analyzer. Adjust the level of the signal generator output until the previously recorded maximum reading for this set of conditions is obtained. This should be done carefully repeating the adjustment of the test antenna and generator output.
- l) Repeat step k) with both antennas vertically polarized for each spurious frequency.
- m) Calculate power in dBm into a reference ideal half-wave dipole antenna by reducing the readings obtained in steps k) and l) by the power loss in the cable between the generator and the antenna, and further corrected for the gain of the substitution antenna used relative to an ideal half-wave dipole antenna by the following formula:

$$Pd(\text{dBm}) = Pg(\text{dBm}) - \text{cable loss (dB)} + \text{antenna gain (dB)}$$

where:

Pd is the dipole equivalent power and

Pg is the generator output power into the substitution antenna.

NOTE:

- 1) It is permissible to use other antennas provided they can be referenced to a dipole.
- 2) For below 1GHz signal, the *antenna gain* (dB) is dBd, and for above 1GHz signal, the *antenna gain* (dB) is dBi
- 3) Effective radiated power (e.r.p) refers to the radiation of a half wave tuned dipole instead of an isotropic antenna. There is a constant difference of 2.15 dB between e.i.r.p. and e.r.p.
 $\text{e.r.p (dBm)} = \text{e.i.r.p. (dBm)} - 2.15$
- 4) For this test, the AU and EU are put outside of the chamber; connect to the RU through the optical fiber



7.2.4.1 Measurement Record:

No emissions were detected within 20dB below the limit for the Downlink direction.

Downlink 1930MHz to 1995MHz:

Lowest Channel					
Frequency	Spurious Emission Level			Limit	Over limit
(MHz)	(Deg)	Polaxis	(dBm)	dBm	(dB)
349.20	80.0	H	-89.88	-13.0	-76.88
499.50	317.0	H	-88.05	-13.0	-75.05
1507.00	359.0	H	-66.19	-13.0	-53.19
2200.00	0.0	H	-61.19	-13.0	-48.19
3900.00	112.0	H	-68.43	-13.0	-55.43
6600.00	0.0	H	-66.02	-13.0	-53.02

Lowest Channel					
Frequency	Spurious Emission Level			Limit	Over limit
(MHz)	(Deg)	Polaxis	(dBm)	dBm	(dB)
189.60	28.0	V	-86.14	-13.0	-73.14
549.00	274.0	V	-87.33	-13.0	-74.33
1694.00	0.0	V	-64.54	-13.0	-51.54
2240.00	259.0	V	-59.32	-13.0	-46.32
3750.00	112.0	V	-69.14	-13.0	-56.14
6900.00	0.0	V	-65.77	-13.0	-52.77



**SGS-CSTC Standards Technical Services Ltd.
Shenzhen Branch**

Report No.: SZEM170600640811

Page: 60 of 90

Middle Channel					
Frequency	Spurious Emission Level			Limit	Over limit
(MHz)	(Deg)	Polaxis	(dBm)	dBm	(dB)
256.80	26.0	H	-84.84	-13.0	-71.84
582.00	275.0	H	-86.25	-13.0	-73.25
1276.00	0.0	H	-67.39	-13.0	-54.39
2200.00	215.0	H	-59.32	-13.0	-46.32
3150.00	112.0	H	-69.67	-13.0	-56.67
9750.00	112.0	H	-64.99	-13.0	-51.99

Middle Channel					
Frequency	Spurious Emission Level			Limit	Over limit
(MHz)	(Deg)	Polaxis	(dBm)	dBm	(dB)
189.60	28.0	V	-85.56	-13.0	-72.56
307.20	55.0	V	-87.96	-13.0	-74.96
1518.00	0.0	V	-66.57	-13.0	-53.57
2208.00	44.0	V	-59.25	-13.0	-46.25
6750.00	0.0	V	-65.73	-13.0	-52.73
11100.00	113.0	V	-64.62	-13.0	-51.62



**SGS-CSTC Standards Technical Services Ltd.
Shenzhen Branch**

Report No.: SZEM170600640811

Page: 61 of 90

Highest Channel					
Frequency	Spurious Emission Level			Limit	Over limit
(MHz)	(Deg)	Polaxis	(dBm)	dBm	(dB)
549.00	359.0	H	-77.95	-13.0	-64.95
791.00	319.0	H	-82.07	-13.0	-69.07
1045.00	142.0	H	-66.11	-13.0	-53.11
1441.00	0.0	H	-66.72	-13.0	-53.72
3600.00	0.0	H	-68.97	-13.0	-55.97
10350.00	111.0	H	-65.25	-13.0	-52.25

Highest Channel					
Frequency	Spurious Emission Level			Limit	Over limit
(MHz)	(Deg)	Polaxis	(dBm)	dBm	(dB)
185.40	190.0	V	-85.45	-13.0	-72.45
387.00	0.0	V	-89.02	-13.0	-76.02
1210.00	192.0	V	-66.28	-13.0	-53.28
2288.00	304.0	V	-59.44	-13.0	-46.44
3300.00	0.0	V	-69.48	-13.0	-56.48
5700.00	0.0	V	-67.14	-13.0	-54.14

Remark:

The cabinet radiation was measured with the equipment transmitting a CW signal into a non-radiating 50 Ohm load at maximum output power on a signal frequency .

Measured were performed in the lowest, middle and highest frequency for the Downlink.

The spectrum was searched from 30MHz to 26GHz (10th Harmonic) for downlink.

7.2.5 Occupied Bandwidth

Test Requirement: FCC part 2.1049
The spectral shape of the output should look similar to input for all modulations.

EUT Operation:
Status: Drive the EUT to maximum output power. .
Conditions: Normal conditions
Application: Cellular Band RF output ports

Test Configuration:

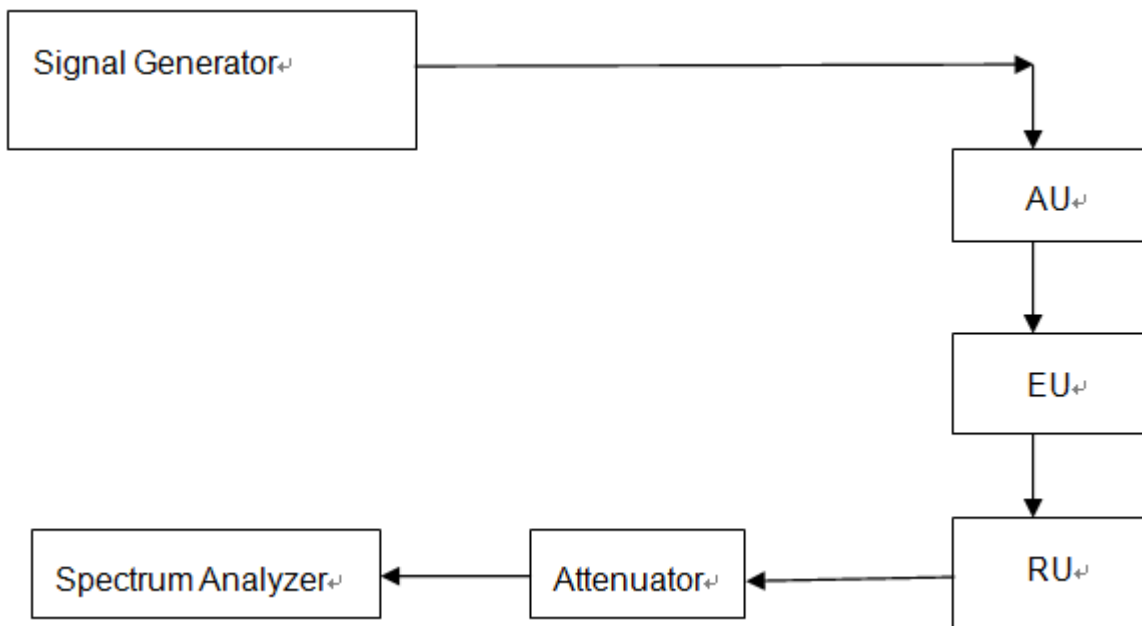

Fig.2. Conducted Spurious Emissions test configuration

Test Procedure:

- Set the spectrum analyzer RBW 300 Hz or $>1\%$ & $<2\%$ emission bandwidth of carrier.
- Capture the trace of input signal;
- Connect the equipment as illustrated;
- Capture the trace of output signal;
- Set the signal power level of the Signal Generator to 0dBm, and the modulation of the signal are LTE(64QAM), CDMA and WCDMA



7.2.5.1 Measurement Record:

1. Downlink: 1930MHz to 1995MHz (LTE mode)

1.1 lowest frequency – 5MHz bandwidth

Input:

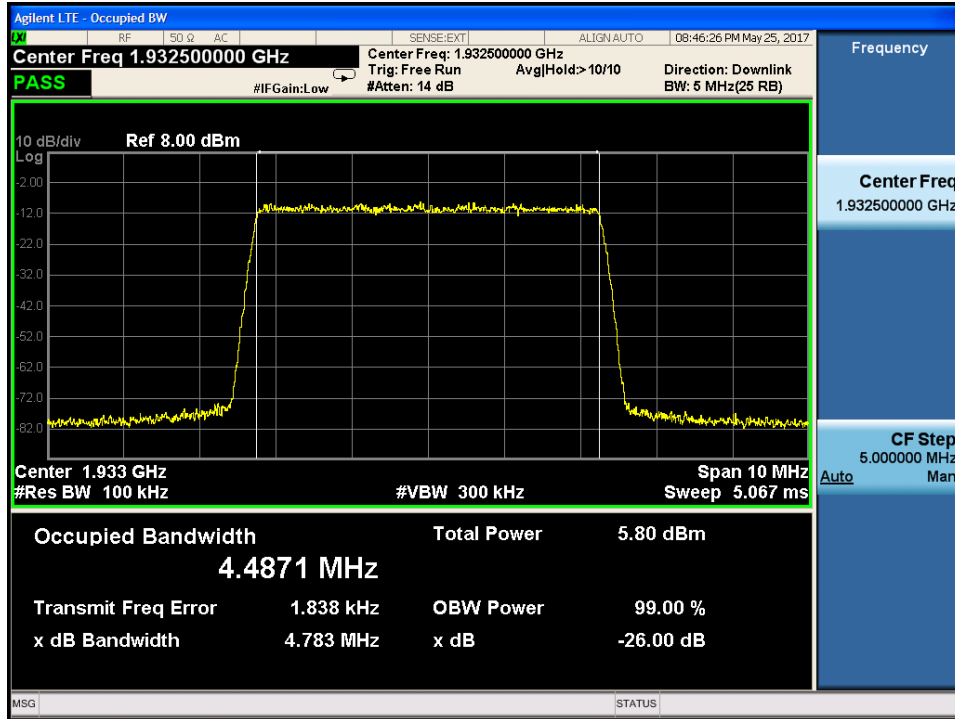

Output:

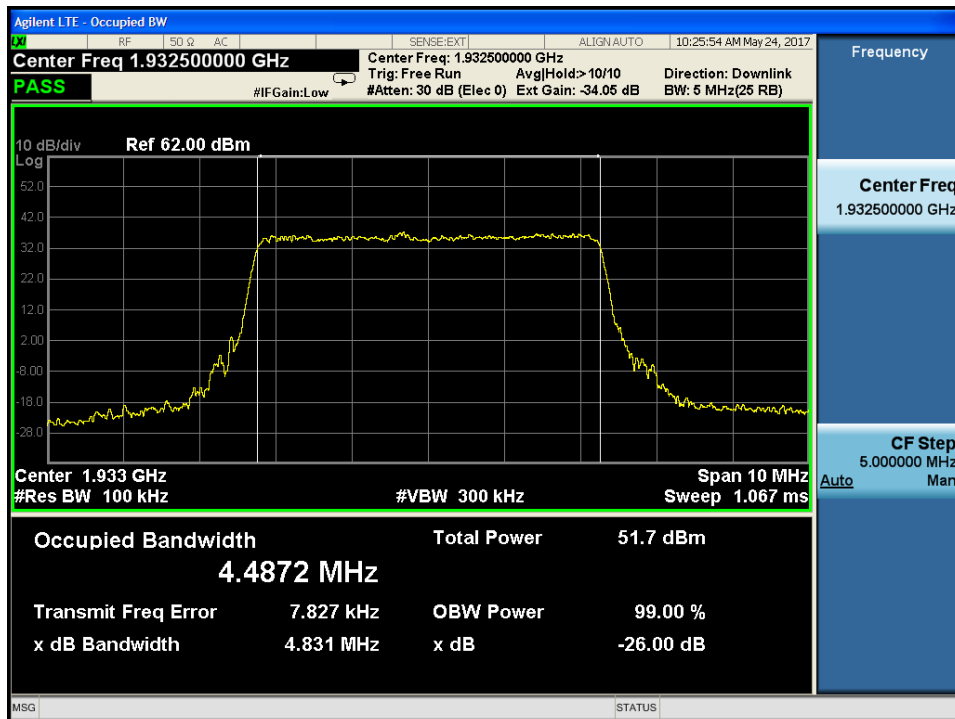



1.2 lowest frequency-- 20MHz bandwidth
Input:

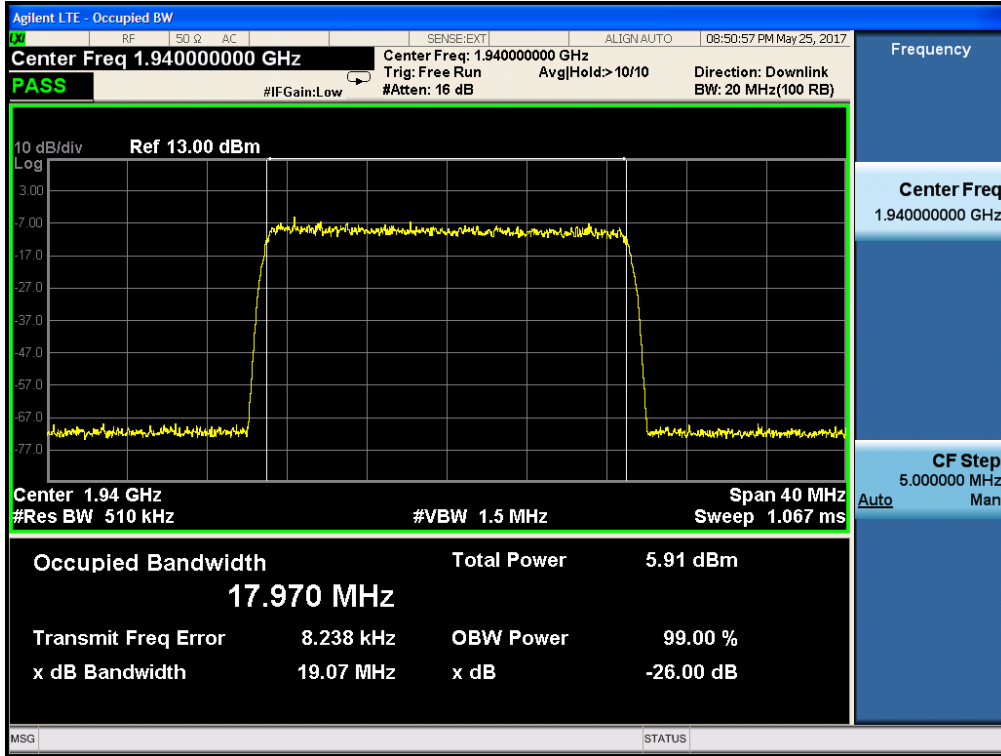

Output:

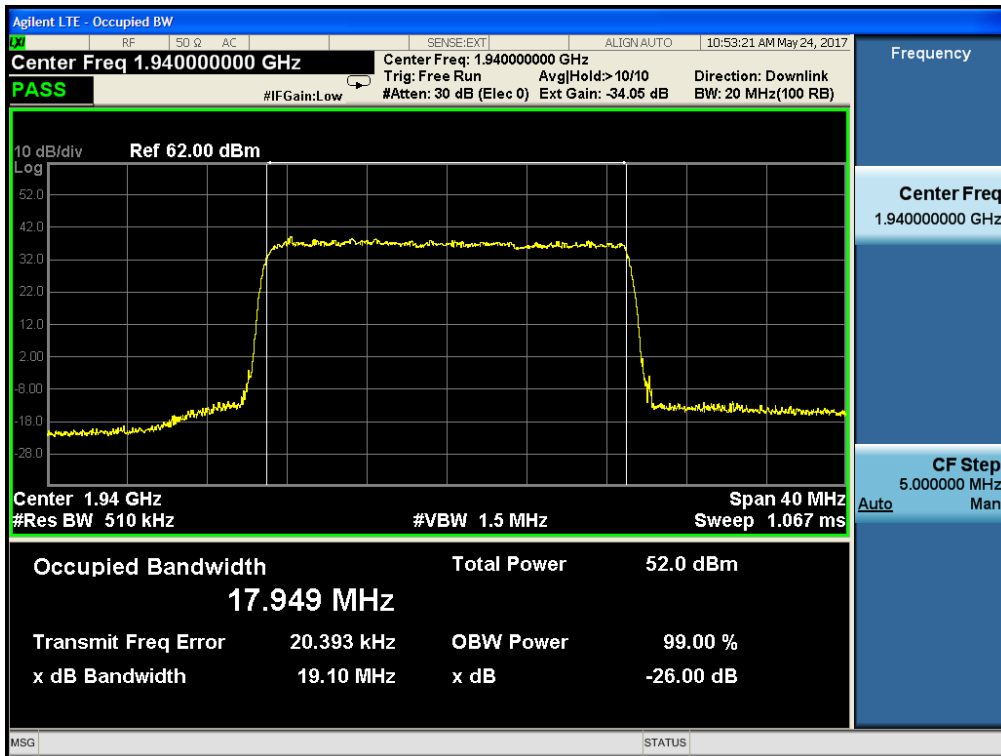



SGS-CSTC Standards Technical Services Ltd. Shenzhen Branch

Report No.: SZEM170600640811
Page: 65 of 90

1.3 middle frequency-- 5MHz bandwidth
Input:

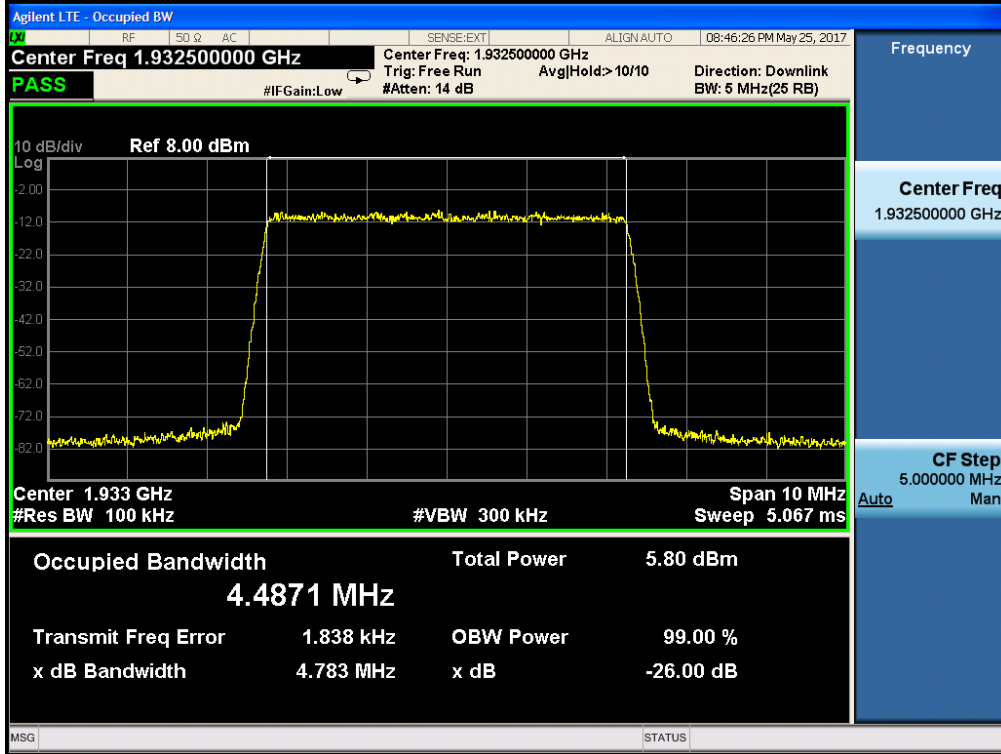

Output:

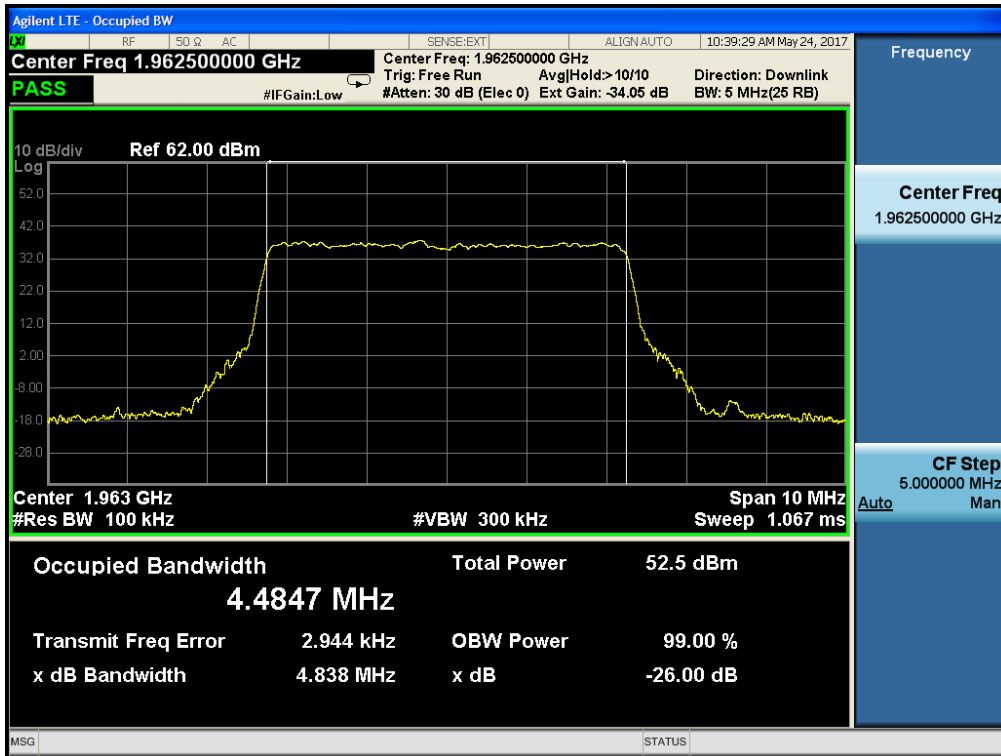



1.4 middle frequency-- 20MHz bandwidth
Input:

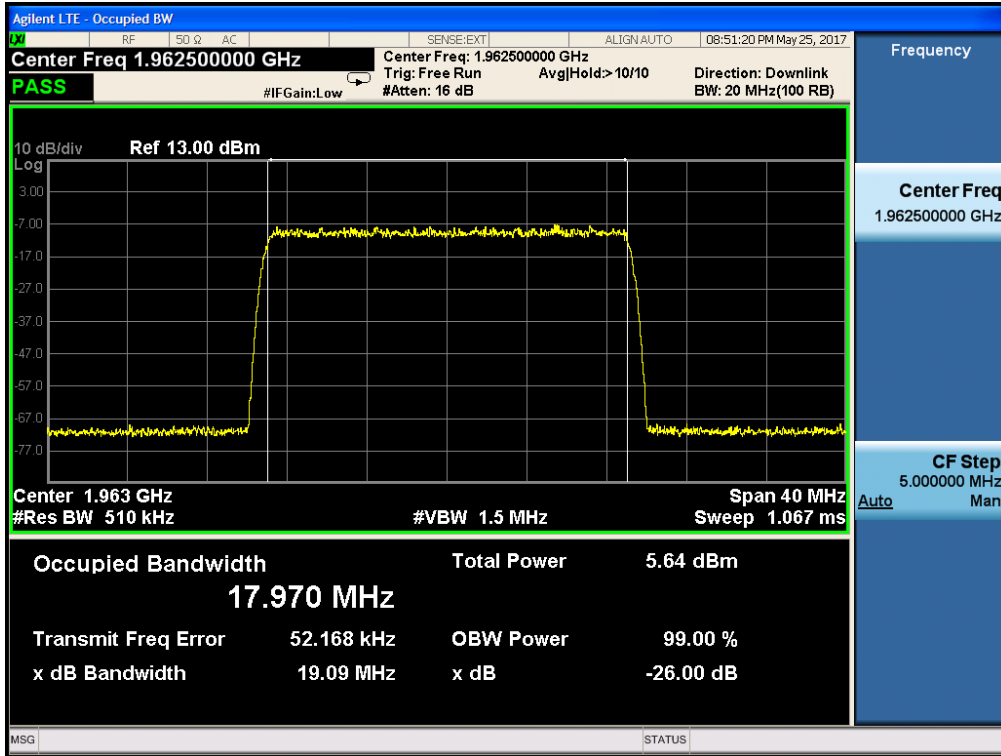

Output:

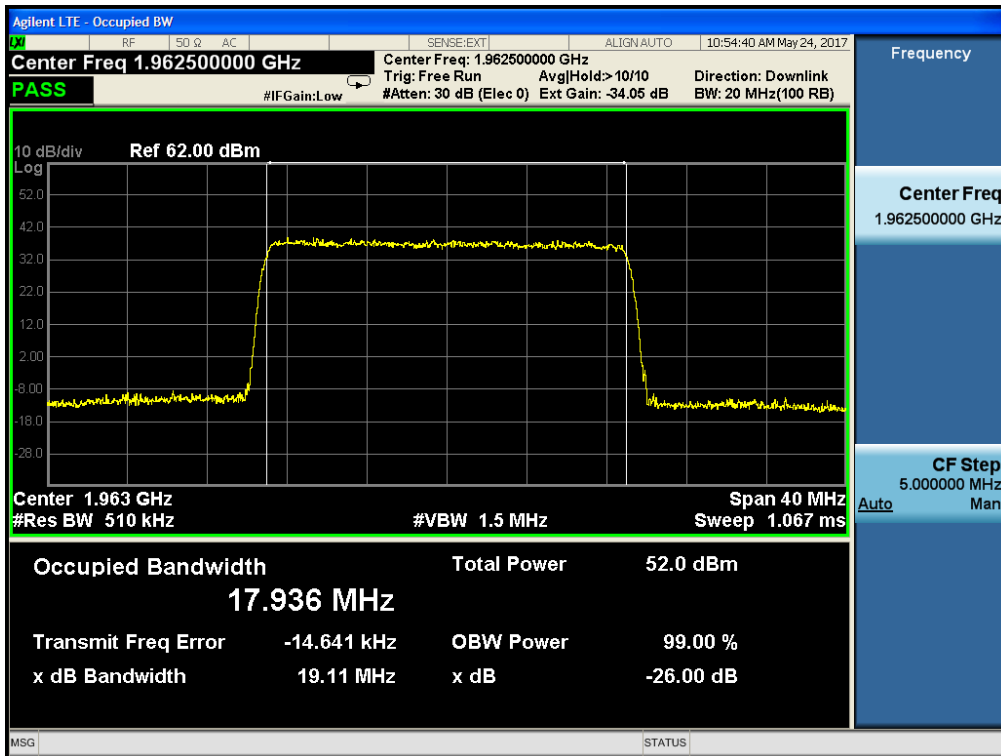



SGS-CSTC Standards Technical Services Ltd. Shenzhen Branch

Report No.: SZEM170600640811
Page: 67 of 90

1.5 highest frequency—5MHz bandwidth
Input:

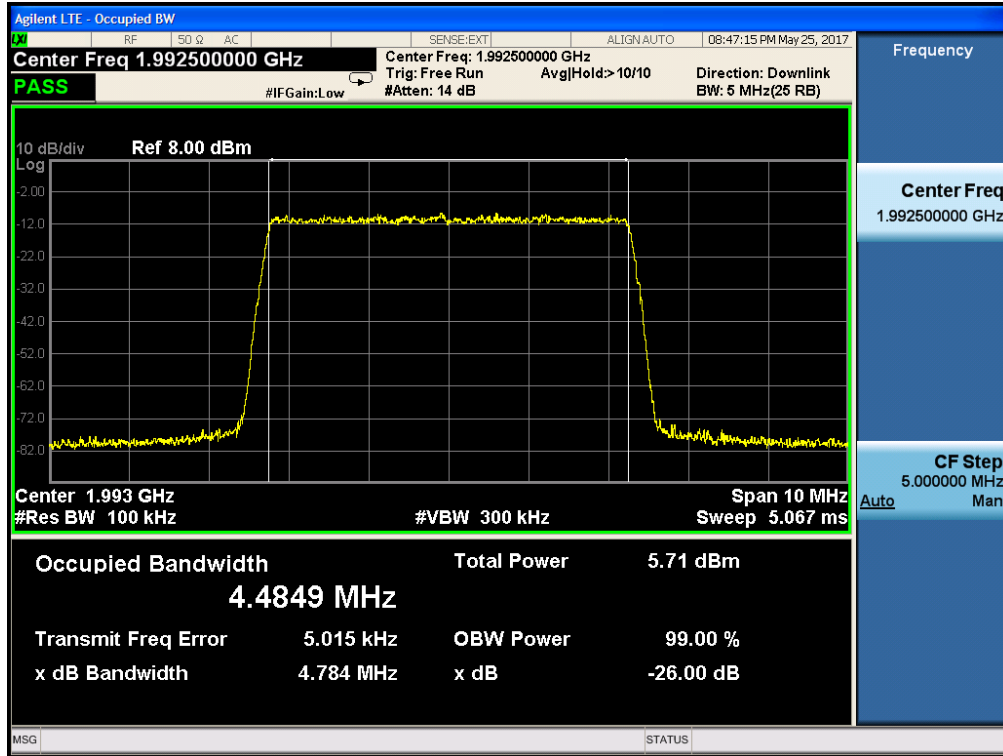

Output:

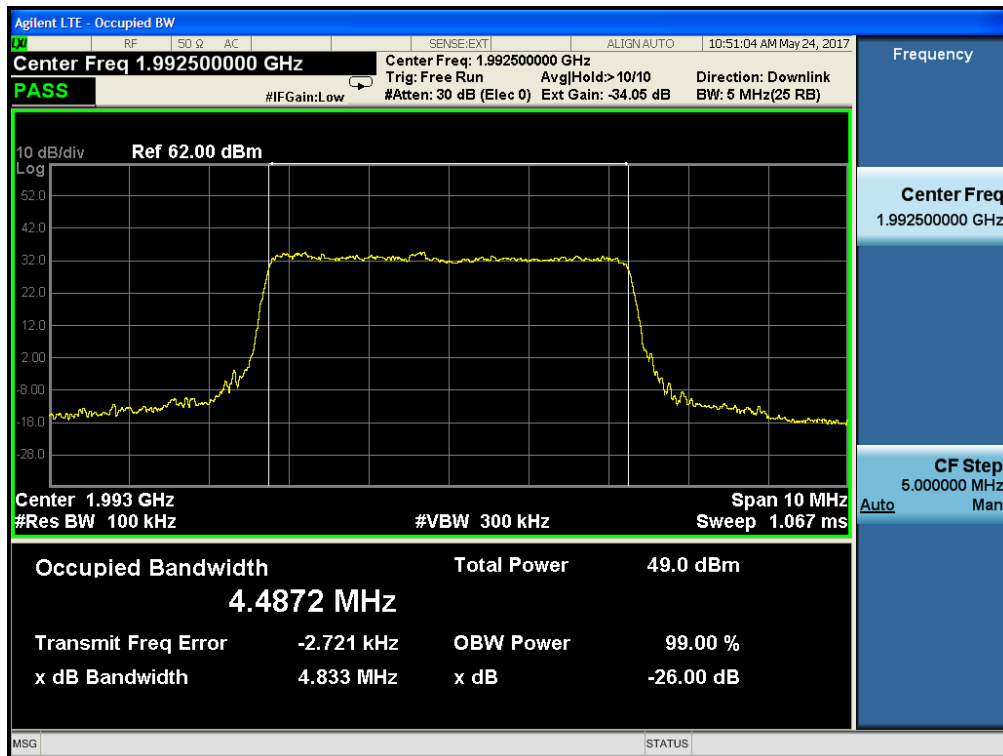



1.6 highest frequency--20MHz bandwidth
Input:

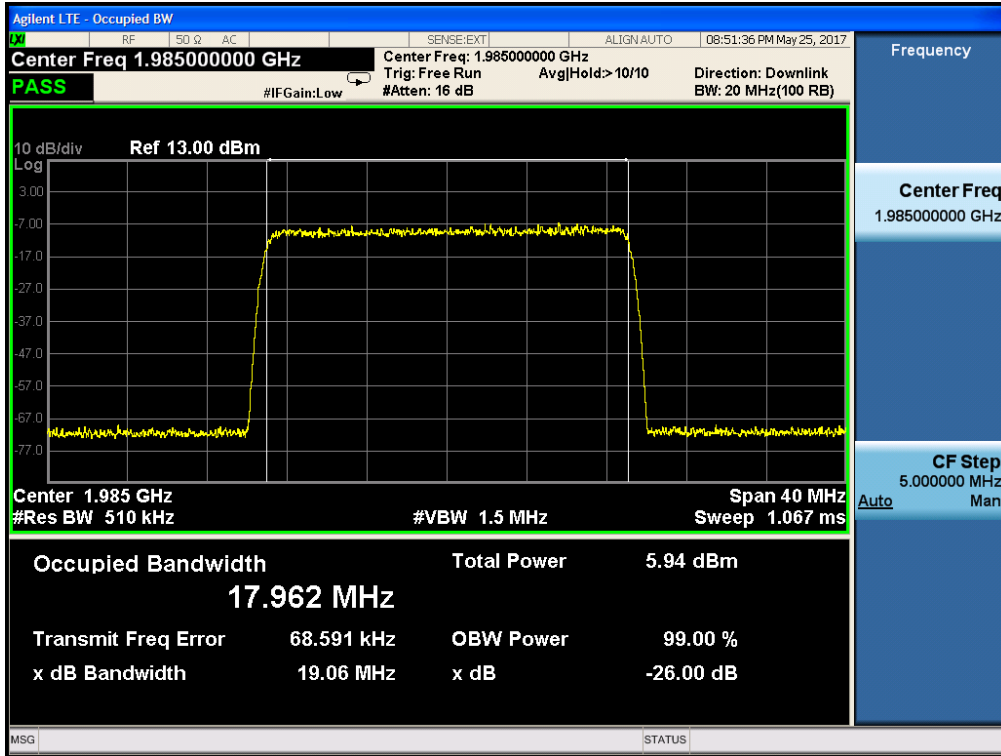

Output:

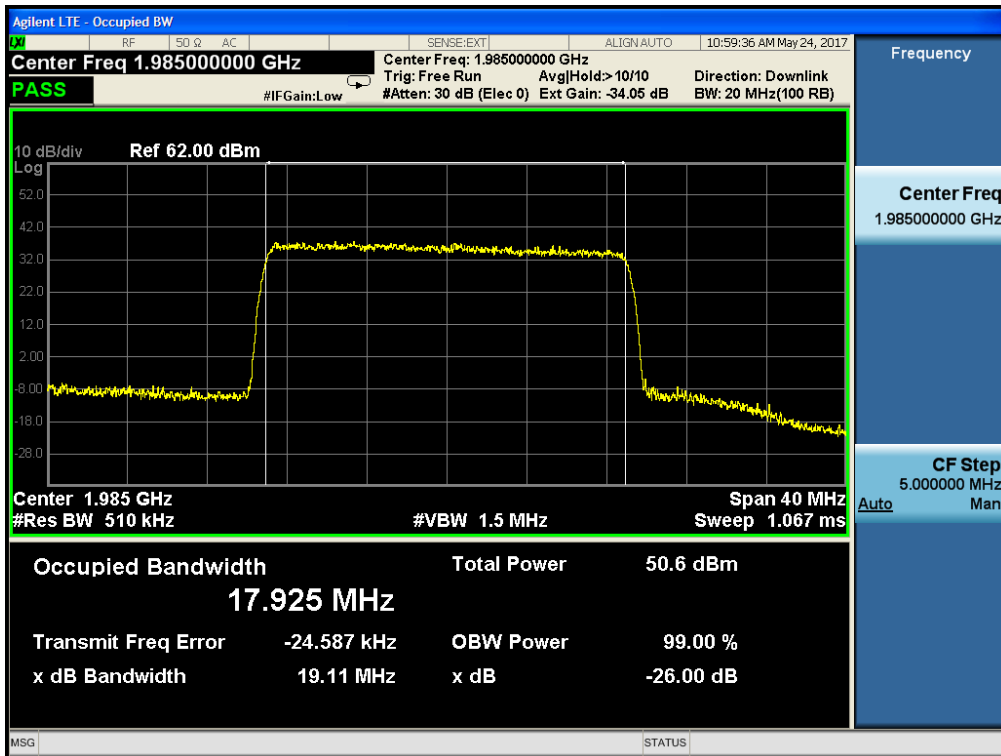



2. Downlink: 1930MHz to 1995MHz(WCDMA mode)

2.1 lowest frequency

Input:

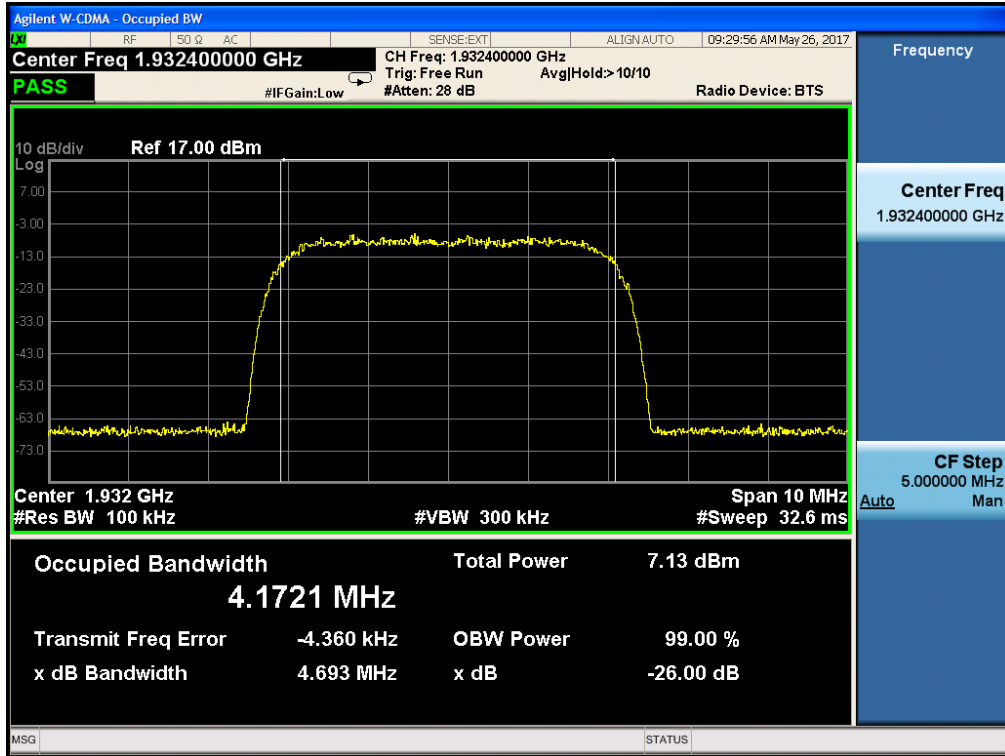

Output:

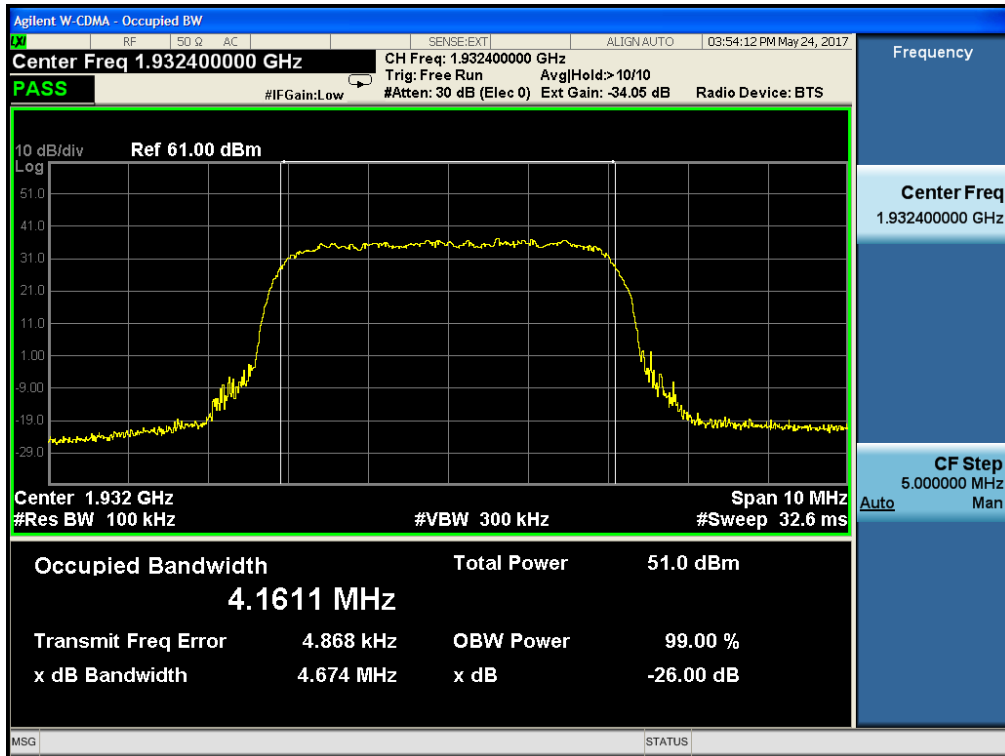



2.2 Middle frequency
Input:

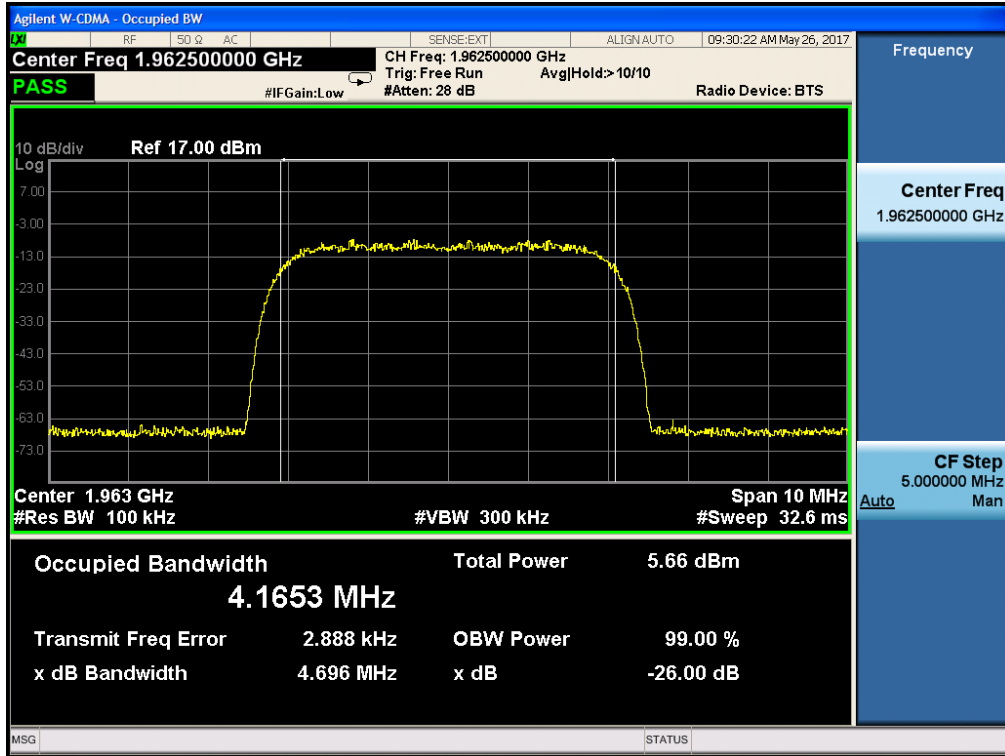

Output:

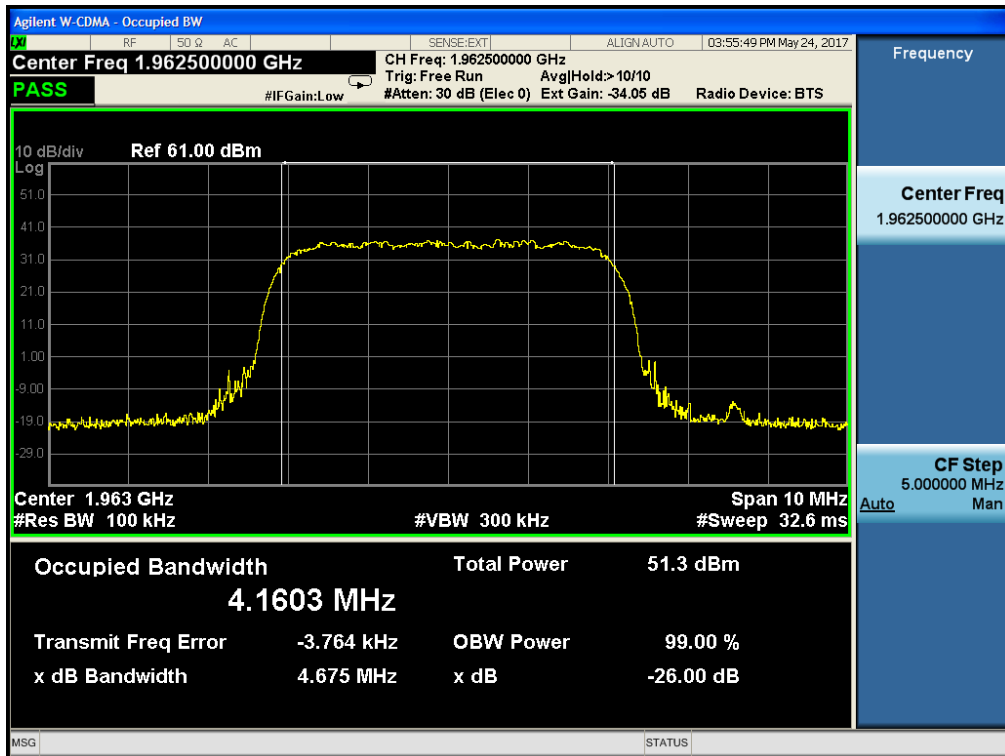



2.3 Highest frequency
Input:

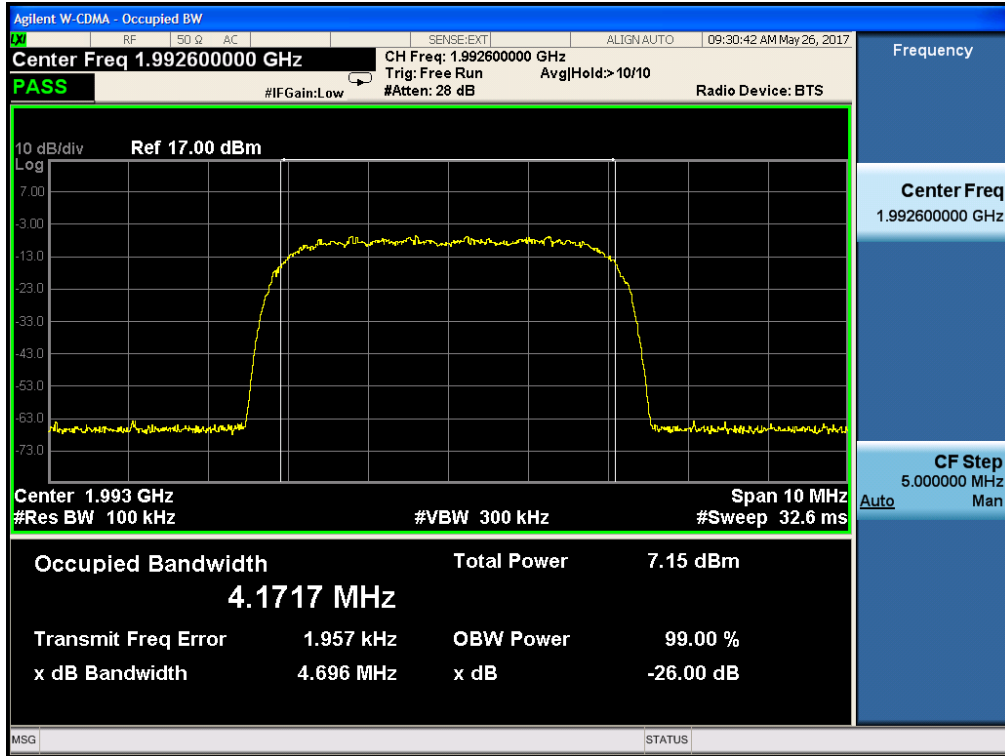

Output:

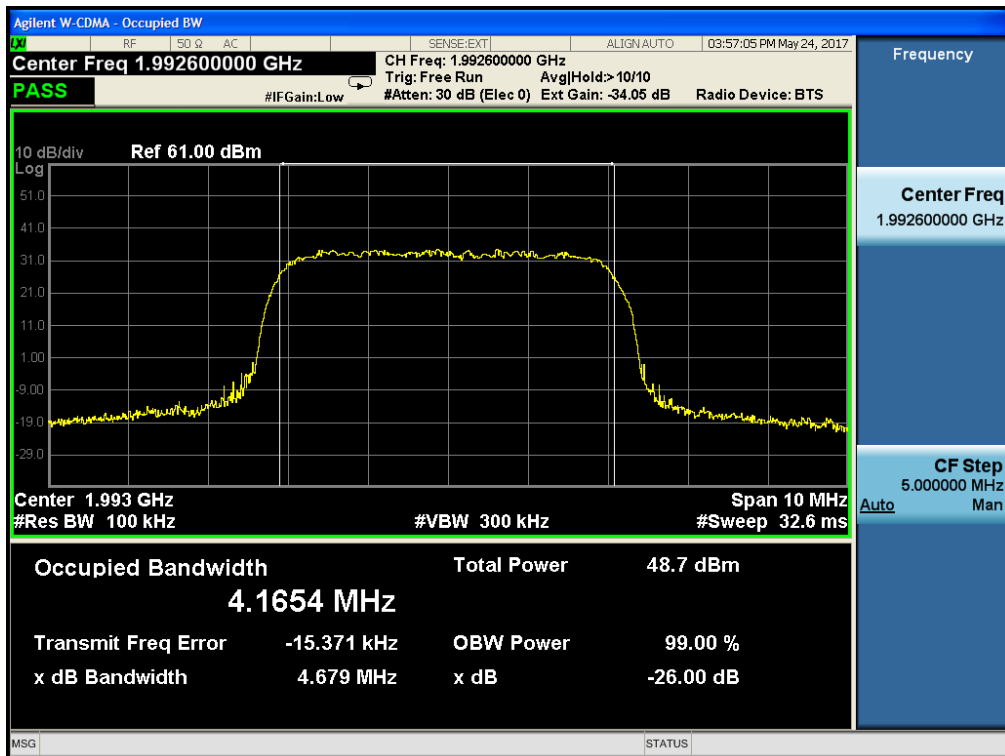



3. Downlink: 1930MHz to 1995MHz (CDMA mode)

3.1 lowest frequency

Input:

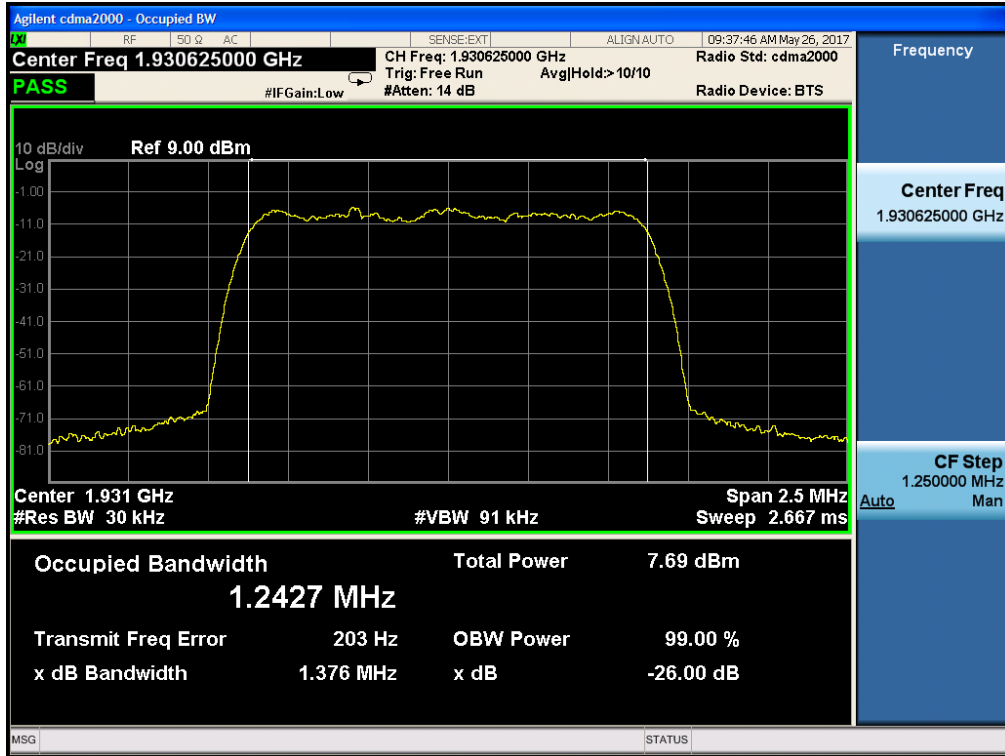

Output:

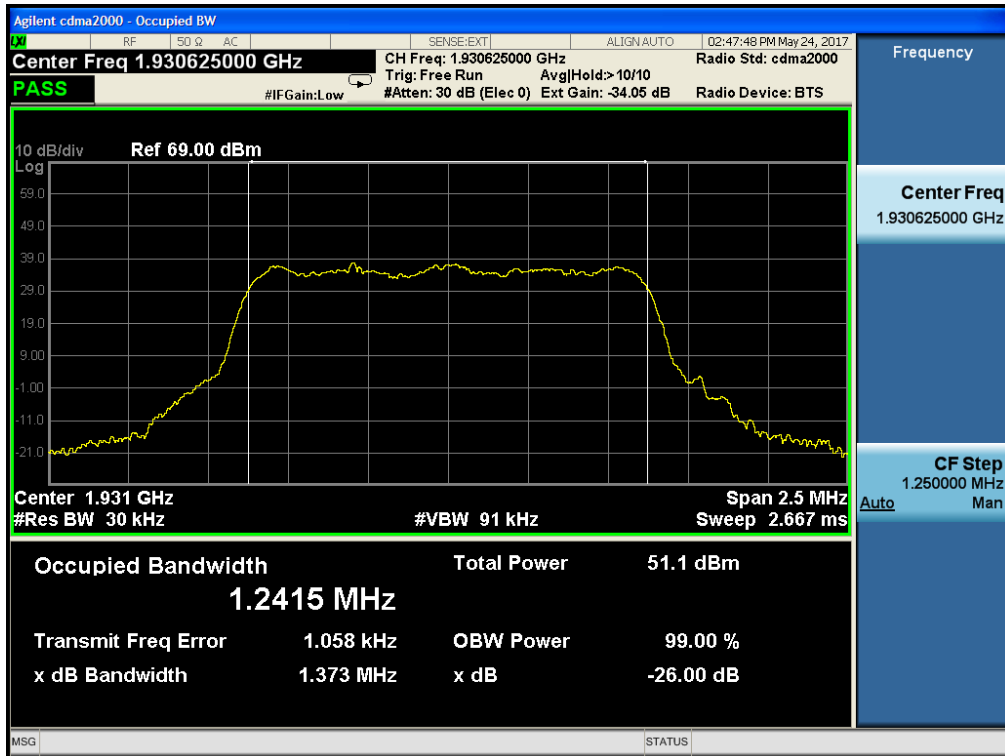



3.2 Middle frequency
Input:

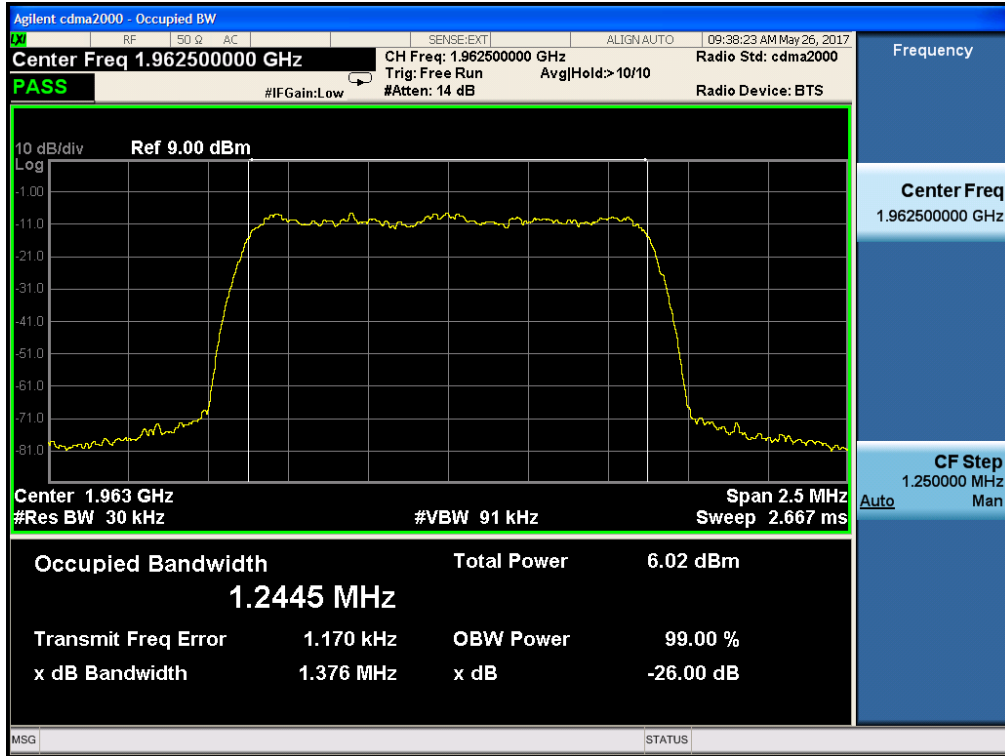

Output:

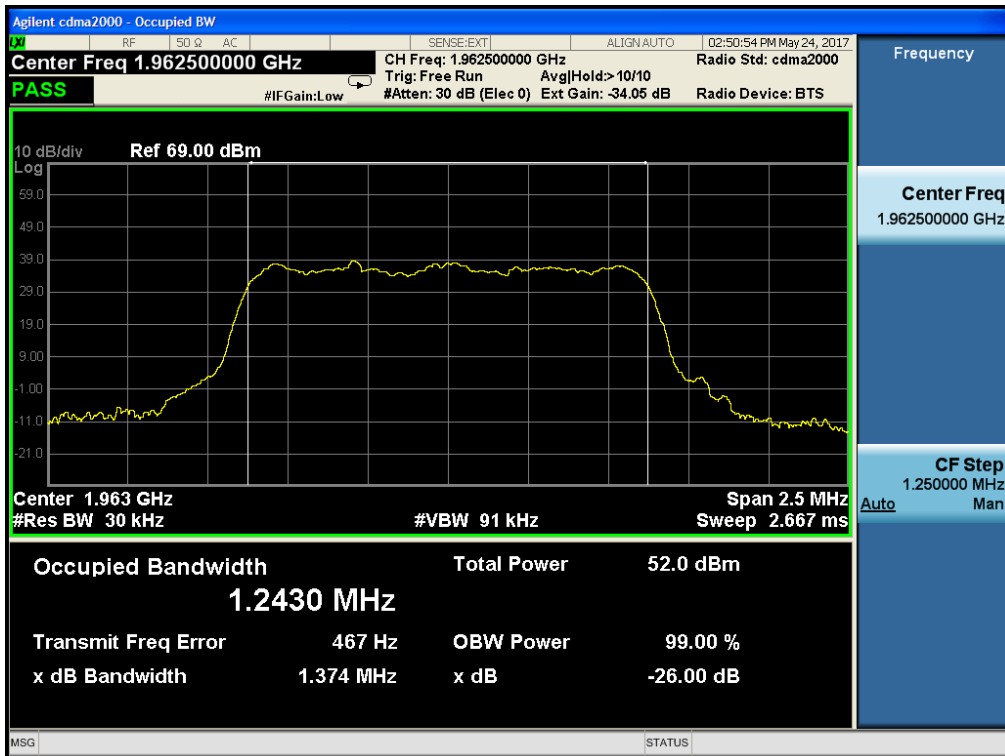



3.3 Highest frequency
Input:

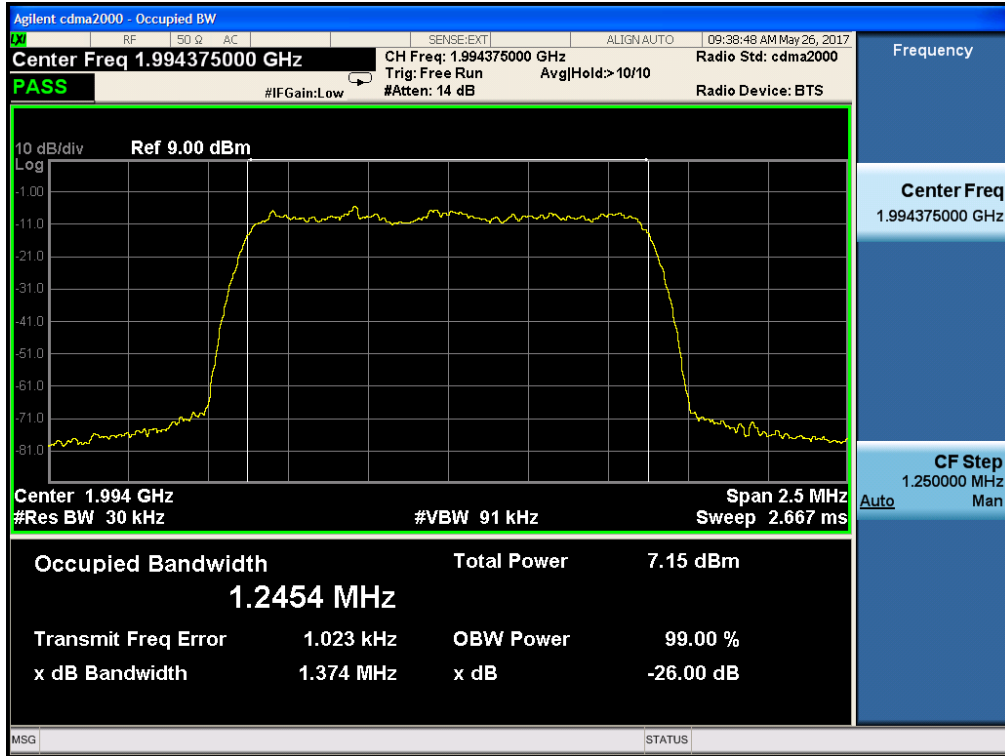

Output:

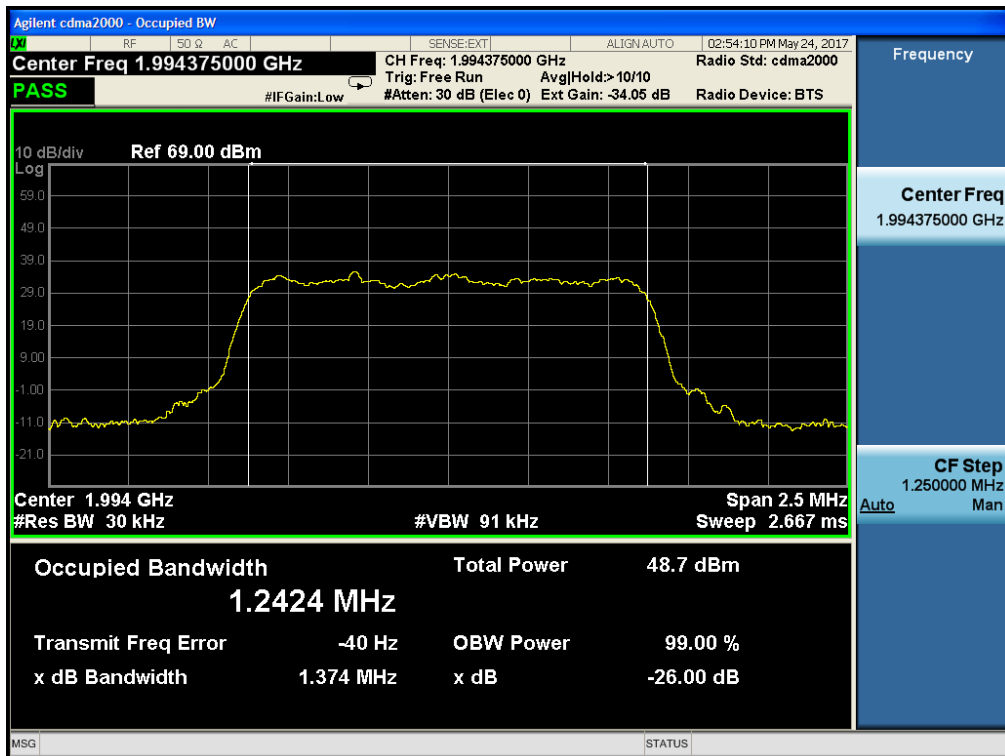

7.2.6 Out of Band Rejection

Test Requirement: Section D.3(l) of KDB 935210 D02 Signal Booster Certification v03r2
Test for rejection of out of band signals. Filter freq. response plots are acceptable.

Test Method: KDB 935210 D05 Indus Booster Basic Meas v01r01

EUT Operation:
Status: Drive the EUT to maximum output power. .
Conditions: Normal conditions
Application: Cellular Band RF output ports

Test Configuration:

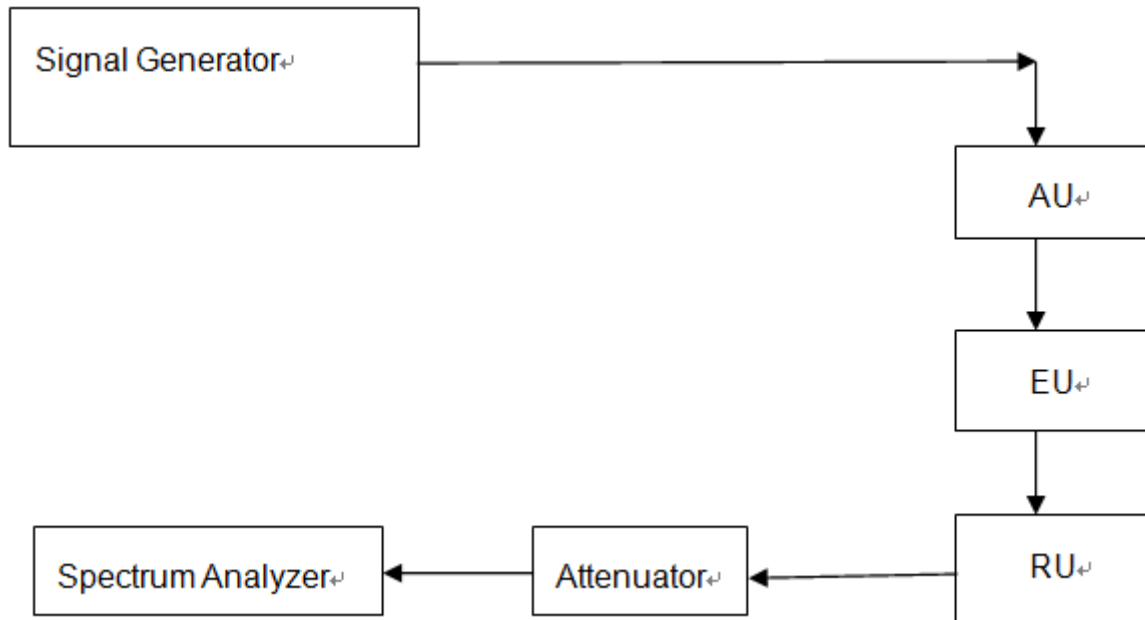

Fig.4. Out of Band rejection test configuration

Test Procedure:

1. Connect the equipment as illustrated;
2. Test the background noise level with all the test facilities;
3. Keep one transmitting path, all other connectors shall be connected by normal power or RF leads;
4. Select the attenuator to avoid the test receiver or spectrum analyzer being destroyed;
5. Keep the EUT continuously transmitting in max power;
6. Signal generator sweep from the frequency more lower than the product frequency to the frequency more higher than it, find the product band filter characteristic;
 - CW signal rather than typical signal is acceptable (for FM).
 - Multiple band filter will need test each other.



7.2.6.1 Measurement Record:

Downlink: 1930MHz to 1995MHz

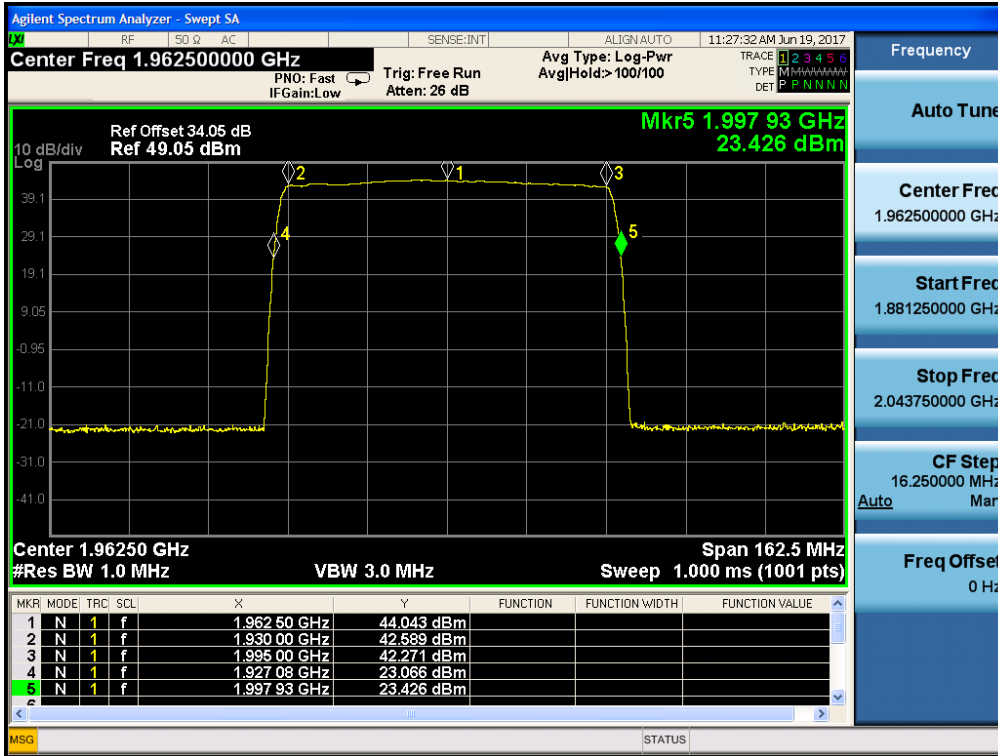



7.2.7 Frequency Stability

Test Requirement: FCC part 24

The frequency stability shall be sufficient to ensure that the fundamental emissions stay within the authorized bands of operation.

EUT Operation:

Status: Drive the EUT to maximum output power.

Conditions: Temperature conditions, voltage conditions

Application: Cellular Band RF output ports

Test Procedure:

1. Temperature conditions:
 - a) The RF output port of the EUT was connected to Frequency Meter;
 - b) Set the working Frequency in the middle channel;
 - c) record the 20°C and nominal voltage frequency value as reference point;
 - d) vary the temperature from -40°C to 50°C with step 10°C
 - e) when reach a temperature point, keep the temperature balance at least 1 hour to make the product working in this status;
 - f) read the frequency at the relative temperature.
2. Voltage conditions:
 - a) record the 20°C and nominal voltage frequency value as reference point;
 - b) vary the voltage from -15% nominal voltage to +15% voltage;
 - c) read the frequency at the relative voltage.



7.2.7.1 Measurement Record:

Frequency Stability vs temperature:

1.Test for Downlink: 1930MHz to 1995MHz (middle channel=1962.5MHz)

Temperature(°C)	Frequency(MHz)	Tolerance(ppm)
50	1962.500006	0.00306
40	1962.500006	0.00306
30	1962.500006	0.00306
20	1962.500006	0.00306
10	1962.500006	0.00306
0	1962.500006	0.00306
-10	1962.500006	0.00306
-20	1962.500006	0.00306
-30	1962.500006	0.00306
-40	1962.500006	0.00306

Frequency Stability vs voltage:

1.Test for Downlink: 1930MHz to 1995MHz (middle channel=1962.5MHz)

Voltage(V ac)	Frequency(MHz)	Tolerance(ppm)
102	1962.500006	0.00306
120	1962.500006	0.00306
138	1962.500006	0.00306

8 Photographs - Test Setup

Above 1GHz Radiated Emission

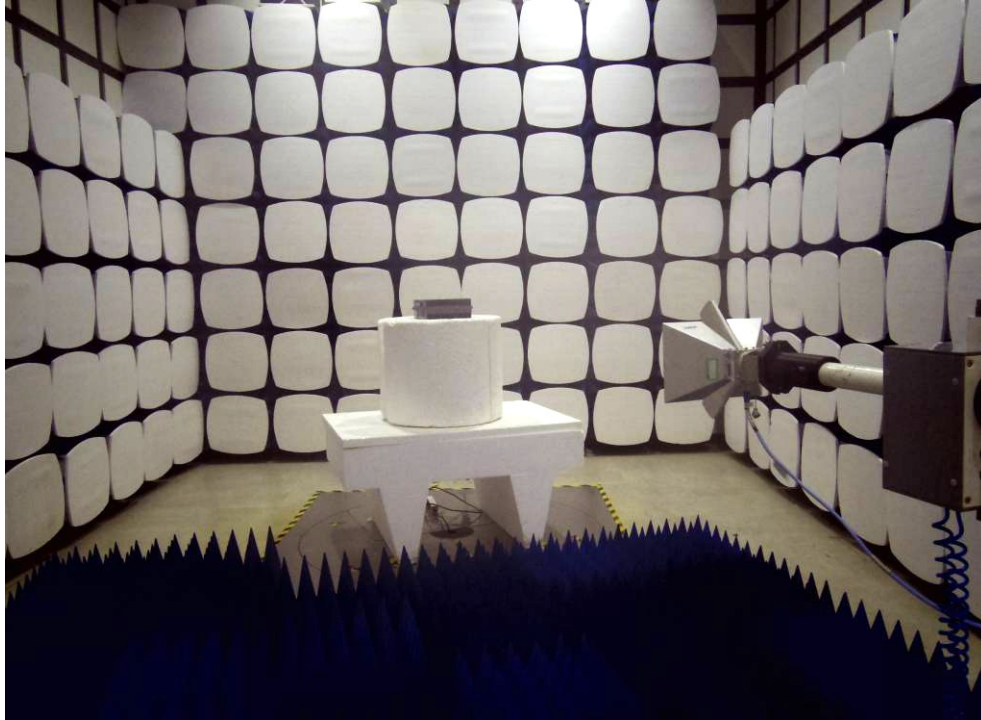

30MHz ~ 1GHz Radiated Emission

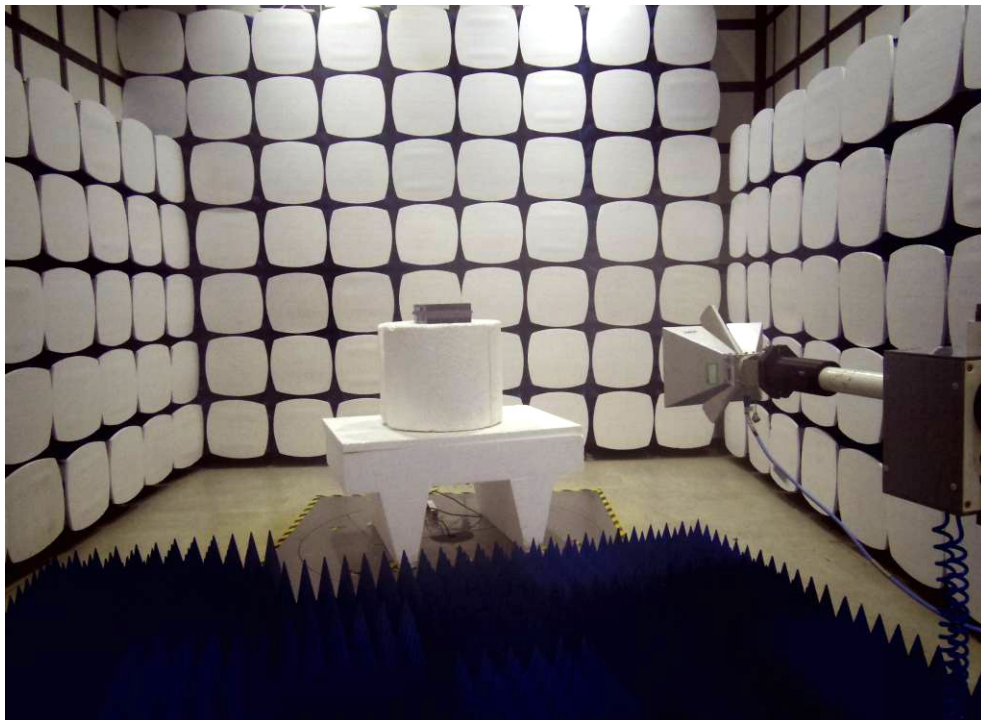

9 Photographs - EUT Constructional Details

Test Model No.: iDAS-R211





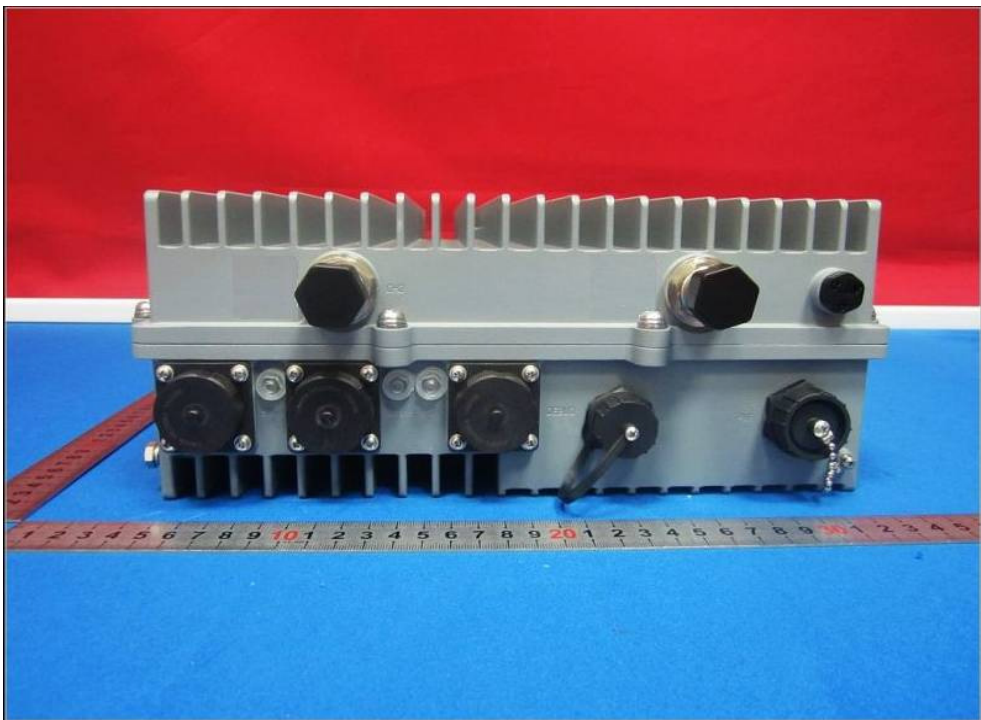

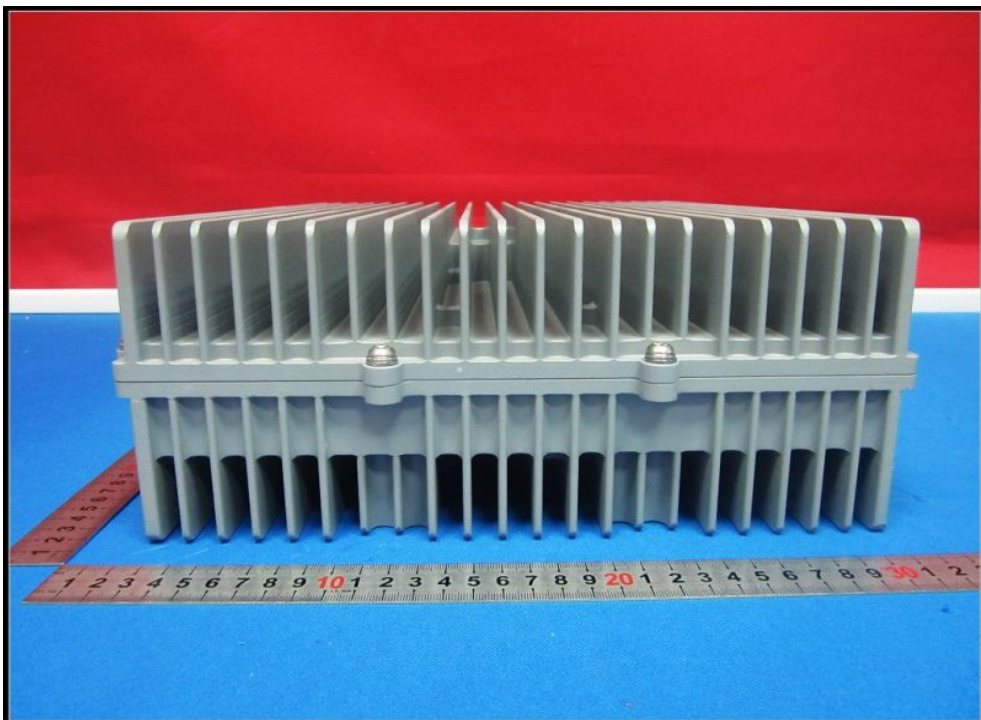

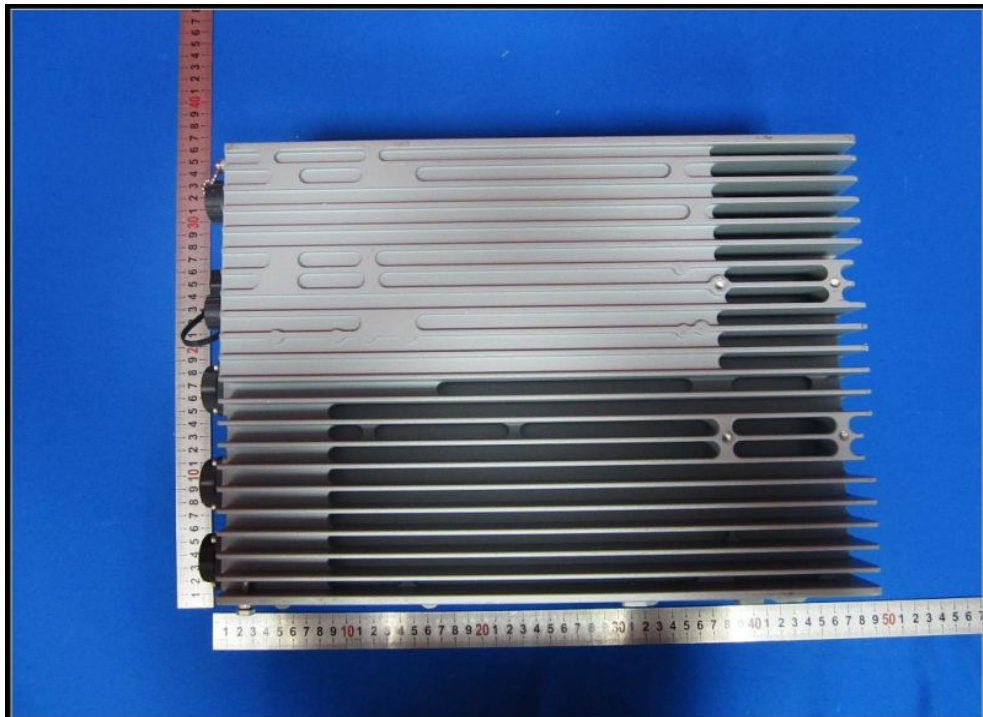
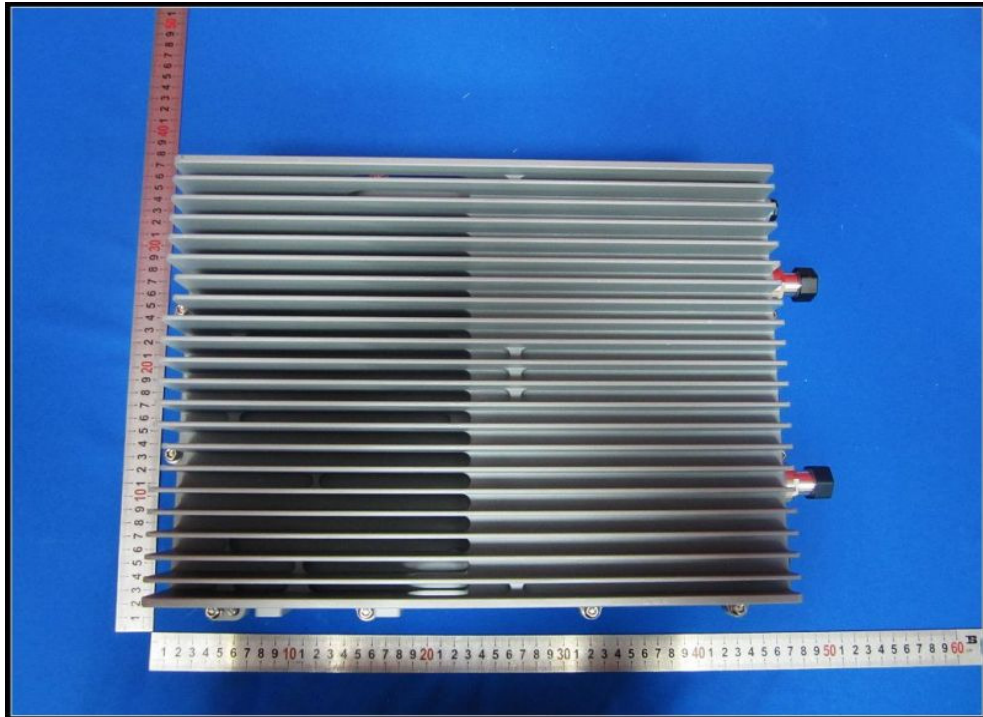

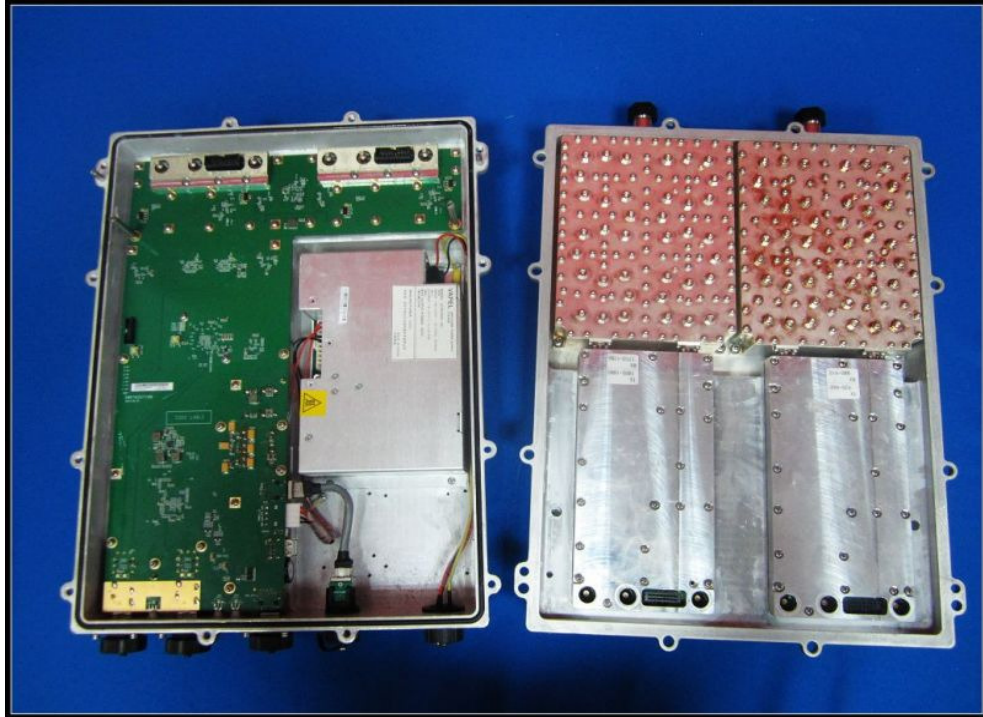

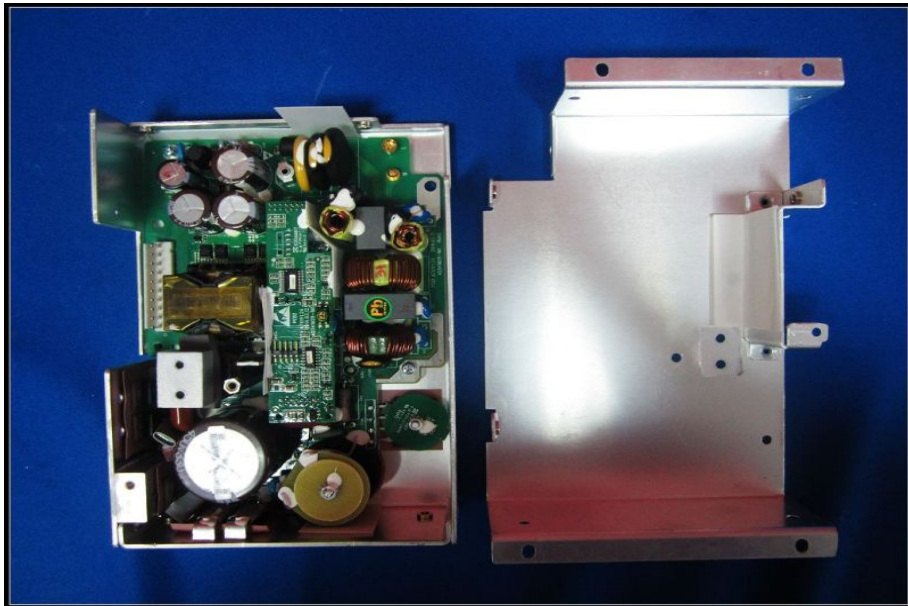
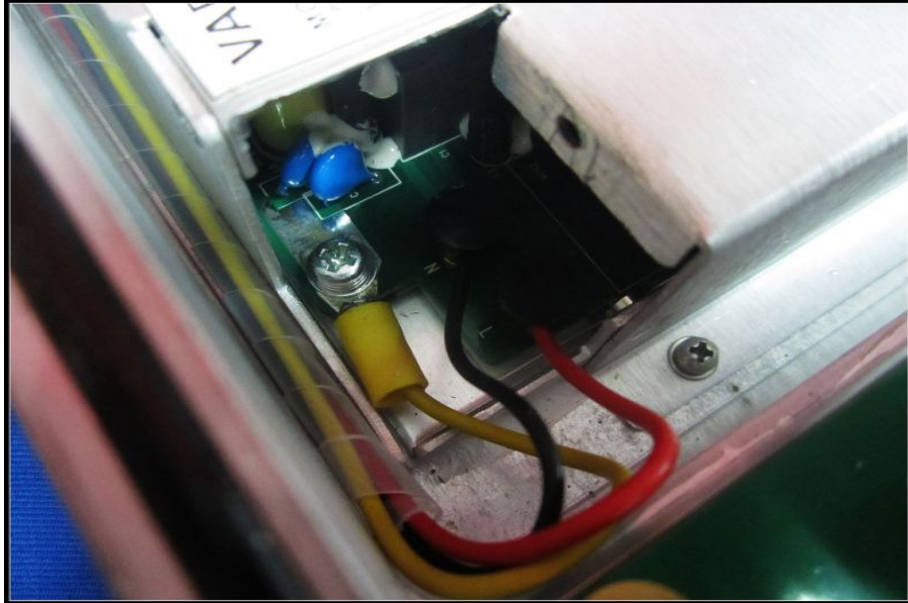

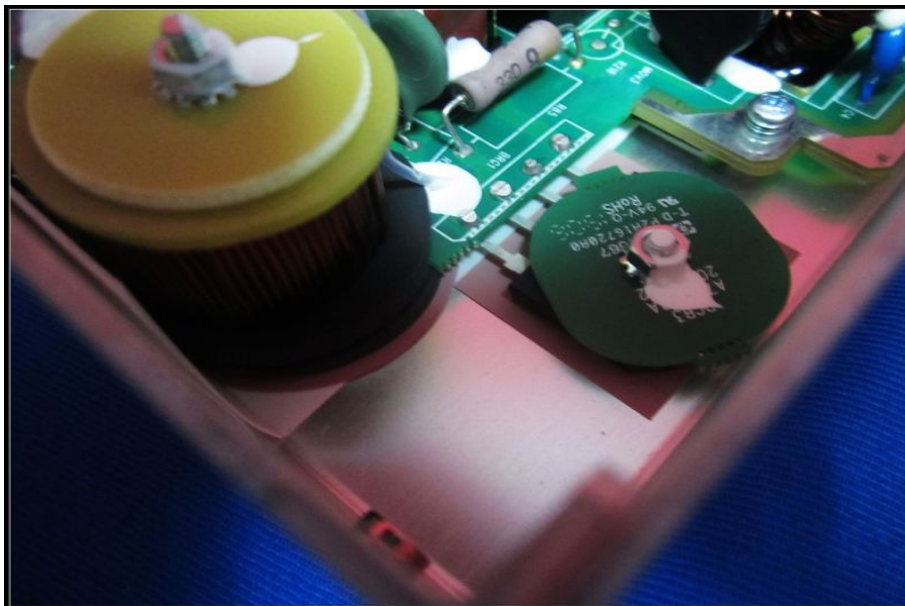
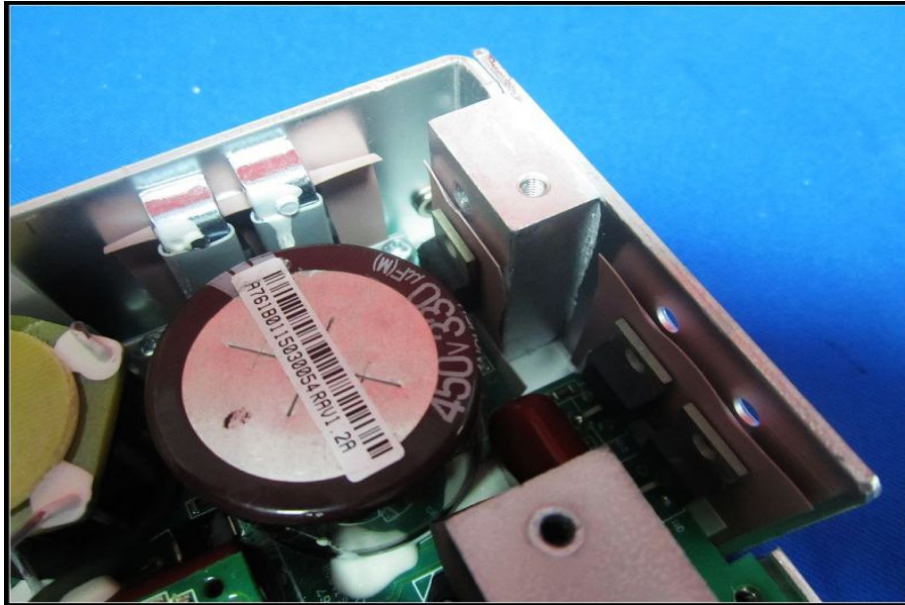

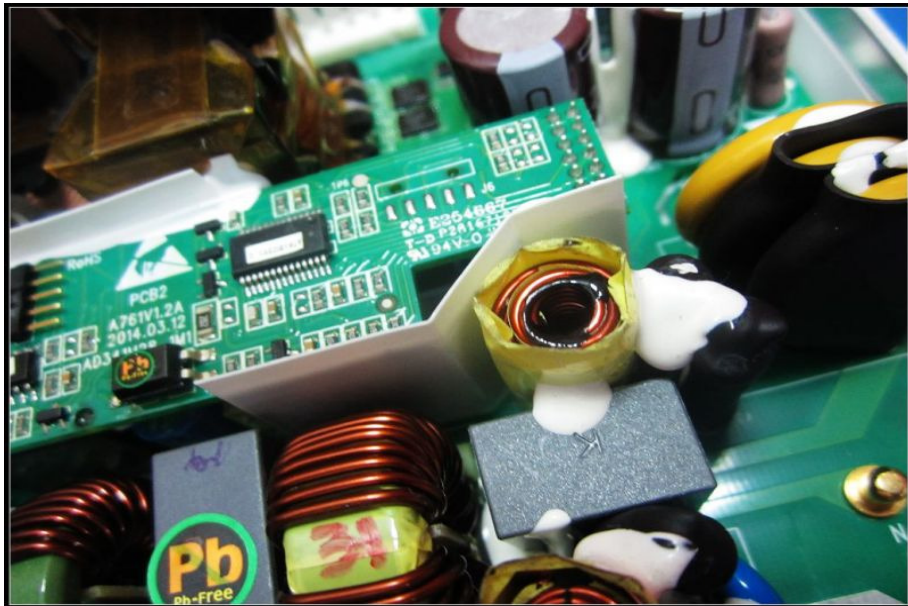
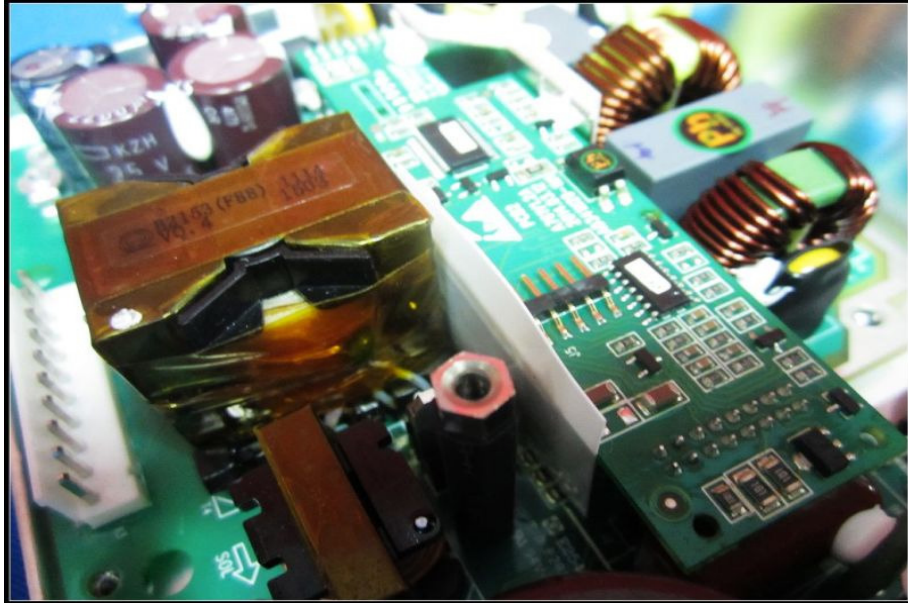

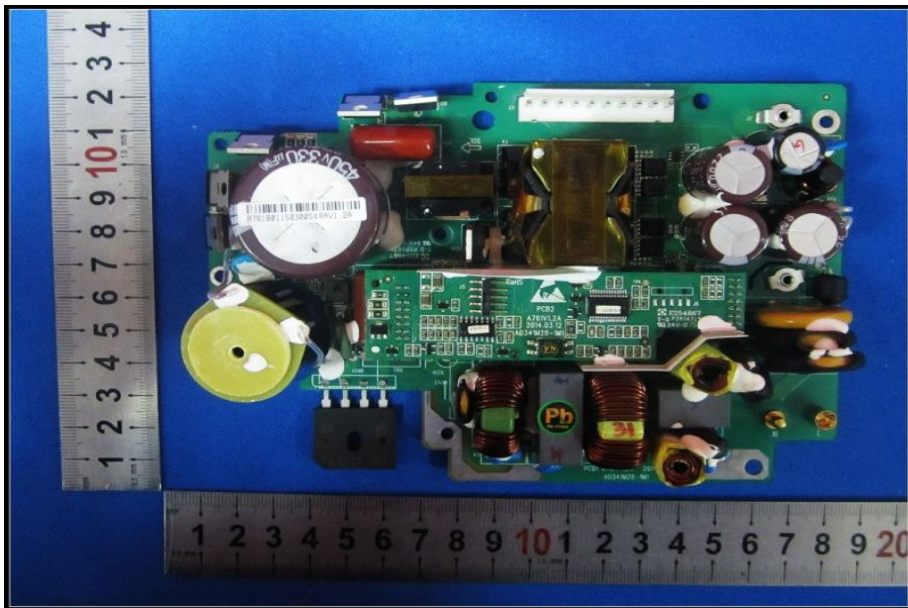
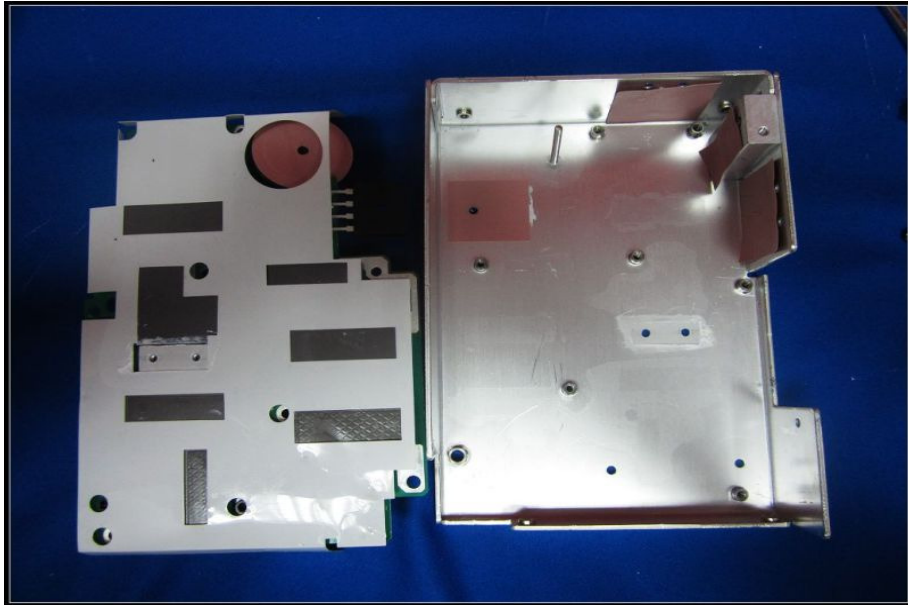

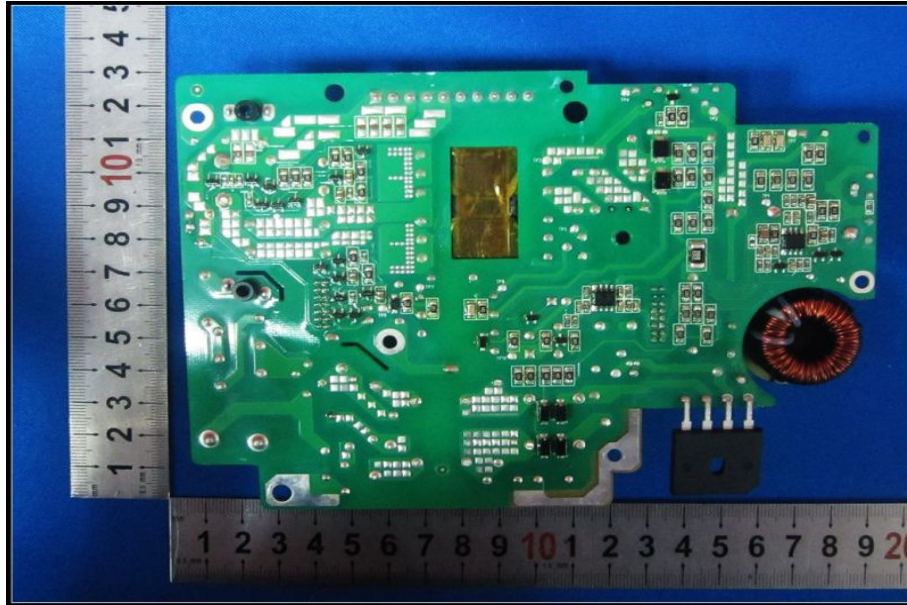

--The End of Report--