

ITEM NO.	PART NUMBER	DESCRIPTION	QTY.
1	000878	Prefold Main Body Assy	1

REVISIONS				
ZONE	REV.	DESCRIPTION	DATE	APPROVED
	1	INITIAL RELEASE	2020-03-23	AWR
	2	CMIIT NUMBER ADDED	05/08/2020	AP
	3	PRESSURE SENSOR REMOVED. RENAMED, WAS "SGP". SITE CODE ADDED TO ARTWORK, REFER REQ-000258.	2020-12-22	AP
	4	ARTWORK UPDATED TO SHOW NEW FCC#. NEW ARTWORK FILENAME . ECO-000073	2021-11-16	AP

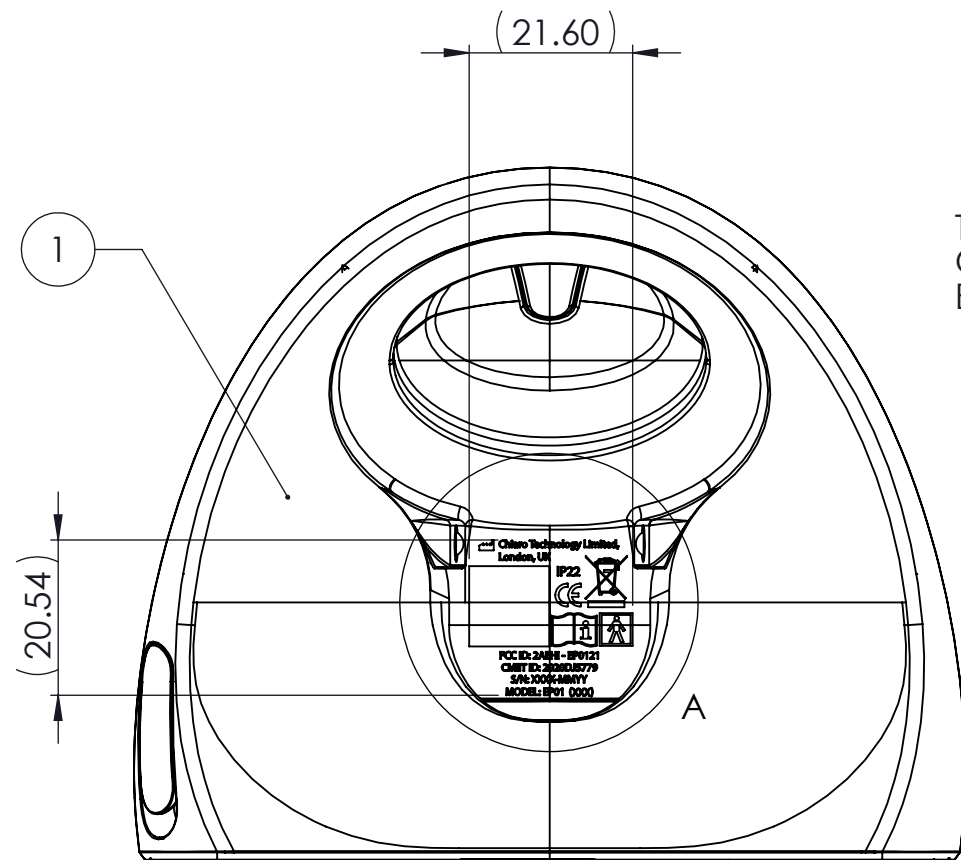

THIS AREA TO BE POPULATED BY QR CODE.
QR CODE TO BE GENERATED BY FVT
BEFORE LASER PRINTING.

4
REFER "AW-001017 MAIN BODY PRODUCT MARKINGS REV (LATEST).AI"
FOR ARTWORK SPECIFICATION.

REFERENCE DIMENSIONS AND MARKING VIEWS FOR GUIDANCE ONLY.
ARTWORK IS MASTER.
ARTWORK SHOULD BE CENTRAL TO MAIN BODY REAR.

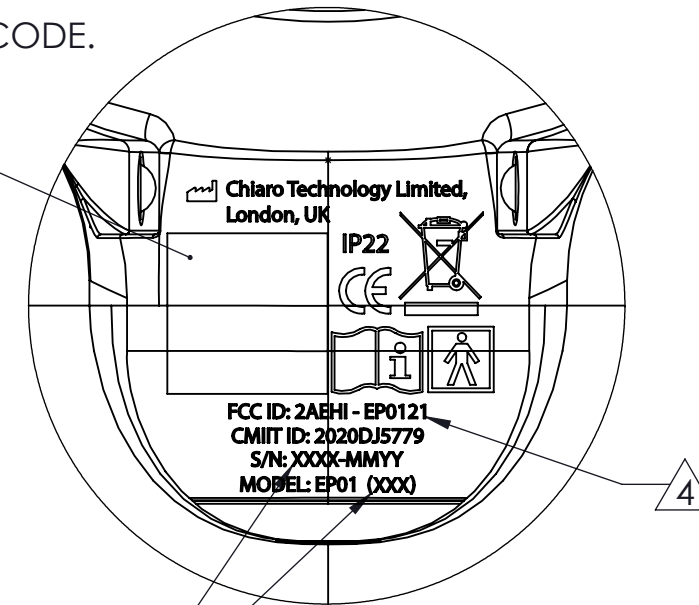

DETAIL A
SCALE 2 : 1

ALL TEXT REMAINS CONSTANT AND AS PER ARTWORK FILE
EXCEPT 9 CHARACTER (INCLUDING HYPHEN) SERIAL NUMBER,
AND 5 CHARACTER (INCLUDING BRACKETS) SITE CODE.
SERIAL NUMBER TO BE GENERATED BY FVT BEFORE LASER
PRINTING.

REFER TO REQ-000258 FOR SPECIFICATION OF SERIAL NUMBER
AND SITE CODE AND QR CODE.

FONT: MS GOTHIC
FONT SIZE: 1MM

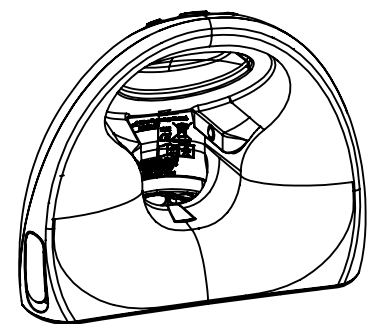

- △ = CHANGE ICON
- ◇ = KEY CHARACTERISTIC
- = LOW CPK CRITICAL FIT

TOLERANCE UNLESS SPECIFIED (±)	
L ≤ 3.0mm	0.13
3.0 < L ≤ 15.0mm	0.20
15.0 < L ≤ 30.0mm	0.25
30.0 < L ≤ 70.0mm	0.45
70.0 < L ≤ 120.0mm	0.60
L > 120.0mm	0.80
ANGLE (degree)	1.0

1. 3D CAD MODEL IS MASTER.
2. THIS DOCUMENT IS THE SOLE PROPERTY OF CHIARO
TECHNOLOGY LTD. & SHOULD NOT BE USED OR
DISTRIBUTED WITHOUT PRIOR WRITTEN CONSENT.

PROJECTION: THIRD ANGLE	DEBUR AND BREAK SHARP EDGES	DO NOT SCALE DRAWING	REVISION: 4
NAME	DATE	CHIARO TECHNOLOGY LTD	
DRAWN: HS	2020-03-12	TITLE: Main Body Product Markings	
CHECKED: -	-	DWG NO. 000875-04	A3
APPROVED: AP	17/11/2021	SCALE: 1:1	SHEET 1 OF 1
MATERIAL FINISH: N/A	N/A	WEIGHT: 133.78	
COLOUR: SEE ARTWORK FILE			