



RADIO TEST REPORT

Test Report No. : 11023664H-A

Applicant : Philips Consumer Lifestyle B.V.
Type of Equipment : Philips Health Watch
Model No. : DL8791
FCC ID : 2AEFK-DL8791
Test regulation : FCC Part 15 Subpart C: 2015
Test Result : Complied

1. This test report shall not be reproduced in full or partial, without the written approval of UL Japan, Inc.
2. The results in this report apply only to the sample tested.
3. This sample tested is in compliance with the above regulation.
4. The test results in this report are traceable to the national or international standards.
5. This test report must not be used by the customer to claim product certification, approval, or endorsement by NVLAP, NIST, or any agency of the Federal Government.
6. This test report covers Radio technical requirements. It does not cover administrative issues such as Manual or non-Radio test related Requirements. (if applicable)

Date of test: June 9 to 14, 2016

Representative test engineer:

Takafumi Noguchi
Engineer
Consumer Technology Division

Approved by:

Tsubasa Takayama
Engineer
Consumer Technology Division



NVLAP LAB CODE: 200572-0

This laboratory is accredited by the NVLAP LAB CODE 200572-0, U.S.A. The tests reported herein have been performed in accordance with its terms of accreditation.
*As for the range of Accreditation in NVLAP, you may refer to the WEB address,
http://japan.ul.com/resources/emc_accredited/

UL Japan, Inc.

Ise EMC Lab.

4383-326 Asama-cho, Ise-shi, Mie-ken 516-0021 JAPAN

Telephone : +81 596 24 8999

Facsimile : +81 596 24 8124

13-EM-F0429

REVISION HISTORY

Original Test Report No.: 11023664H-A

Revision	Test report No.	Date	Page revised	Contents
- (Original)	11023664H-A	June 16, 2016	-	-

CONTENTS	PAGE
SECTION 1: Customer information.....	4
SECTION 2: Equipment under test (E.U.T.).....	4
SECTION 3: Test specification, procedures & results.....	5
SECTION 4: Operation of E.U.T. during testing.....	8
SECTION 5: Radiated Spurious Emission	10
SECTION 6: Antenna Terminal Conducted Tests.....	12
APPENDIX 1: Test data	13
6dB Bandwidth	13
Maximum Peak Output Power	15
Average Output Power	16
Radiated Spurious Emission	18
Conducted Spurious Emission	24
Power Density	27
99%Occupied Bandwidth	29
APPENDIX 2: Test instruments	30
APPENDIX 3: Photographs of test setup	31
Radiated Spurious Emission	31
Worst Case Position	32

SECTION 1: Customer information

Company Name : Philips Consumer Lifestyle B.V.
Address : Tussendiepen 4, 9206 AD Drachten, The Netherlands
Contact Person : Wilbert Pennings

SECTION 2: Equipment under test (E.U.T.)

2.1 Identification of E.U.T.

Type of Equipment : Philips Health Watch
Model No. : DL8791
Serial No. : Refer to Section 4, Clause 4.2
Rating : DC 3.7 V (internal battery), USB charging cradle: DC 5 V
Receipt Date of Sample : June 7, 2016
Country of Mass-production : China
Condition of EUT : Engineering prototype
(Not for Sale: This sample is equivalent to mass-produced items.)
Modification of EUT : No Modification by the test lab

2.2 Product Description

Model: DL8791 (referred to as the EUT in this report) is a Philips Health Watch.

General Specification

Clock frequency(ies) in the system : Bluetooth chip 48 MHz;
other frequencies in the system: 24 MHz, 2.09 MHz, 32.768 kHz, 16 MHz,
5 to 200 kHz(the switching frequency range (from 5 to 200 KHz) of the
Buck Converter), 222 kHz

Radio Specification

Bluetooth Low Energy

Radio Type : Transceiver
Frequency of Operation : 2402 MHz - 2480 MHz
Modulation : GFSK
Power Supply (radio part input) : DC 3.0 V
Antenna type : Monopole type (internal)
Antenna Gain : 0 dBi
Operating temperature range : +5 to +40deg.C

Model differences

Model DL8790, DL8791 and DL8792 are identical. Only difference is the model number.

UL Japan, Inc.

Ise EMC Lab.

4383-326 Asama-cho, Ise-shi, Mie-ken 516-0021 JAPAN

Telephone : +81 596 24 8999

Facsimile : +81 596 24 8124

SECTION 3: Test specification, procedures & results

3.1 Test Specification

Test Specification : FCC Part 15 Subpart C: 2015, final revised on November 23, 2015
*Some parts are effective on and after December 17, 2015 or December 23, 2015. The revision does not affect the test specification applied to the EUT.

Title : FCC 47CFR Part15 Radio Frequency Device Subpart C Intentional Radiators
Section 15.207 Conducted limits
Section 15.247 Operation within the bands 902-928MHz,
2400-2483.5MHz, and 5725-5850MHz

3.2 Procedures and results

Item	Test Procedure	Specification	Worst margin	Results	Remarks
Conducted Emission	FCC: ANSI C63.10-2013 6. Standard test methods IC: RSS-Gen 8.8	FCC: Section 15.207 IC: RSS-Gen 8.8	N/A	N/A	N/A *1)
6dB Bandwidth	FCC: KDB 558074 D01 DTS Meas Guidance v03r05 IC: -	FCC: Section 15.247(a)(2) IC: RSS-247 5.2(1)	See data.	Complied	Conducted
Maximum Peak Output Power	FCC: KDB 558074 D01 DTS Meas Guidance v03r05 IC: RSS-Gen 6.12	FCC: Section 15.247(b)(3) IC: RSS-247 5.4(4)		Complied	Conducted
Power Density	FCC: KDB 558074 D01 DTS Meas Guidance v03r05 IC: -	FCC: Section 15.247(e) IC: RSS-247 5.2(2)		Complied	Conducted
Spurious Emission Restricted Band Edges	FCC: ANSI C63.10-2013 : KDB 558074 D01 DTS Meas Guidance v03r05 IC: ANSI C63.10-2013 RSS-Gen 6.13	FCC: Section15.247(d) IC: RSS-247 5.5 RSS-Gen 8.9 RSS-Gen 8.10	0.4 dB 4804.000 MHz, Horizontal, AV	Complied	Conducted (below 30 MHz)/ Radiated (above 30 MHz) *2)

Note: UL Japan, Inc.'s EMI Work Procedures No. 13-EM-W0420 and 13-EM-W0422.

*1) The test is not applicable since the EUT is not the device that is designed to be connected to the public utility (AC) power line.

*2) Radiated test was selected over 30 MHz based on section 15.247(d) and KDB 558074 D01 DTS Meas Guidance v03r05 12.2.7.

* In case any questions arise about test procedure, ANSI C63.10: 2013 is also referred.

FCC Part 15.31 (e)

This EUT provides stable voltage (DC 3.0 V) constantly to RF Module regardless of input voltage. Therefore, this EUT complies with the requirement.

FCC Part 15.203 Antenna requirement

It is impossible for end users to replace the antenna, because the antenna is mounted inside of the EUT. Therefore, the equipment complies with the antenna requirement of Section 15.203.

UL Japan, Inc.

Ise EMC Lab.

4383-326 Asama-cho, Ise-shi, Mie-ken 516-0021 JAPAN

Telephone : +81 596 24 8999

Facsimile : +81 596 24 8124

3.3 Addition to standard

Item	Test Procedure	Specification	Worst margin	Results	Remarks
99% Occupied Bandwidth	IC: RSS-Gen 6.6	IC: -	N/A	-	Conducted

Other than above, no addition, exclusion nor deviation has been made from the standard.

3.4 Uncertainty

EMI

The following uncertainties have been calculated to provide a confidence level of 95 % using a coverage factor $k = 2$.

Ise EMC Lab.

Antenna terminal test Uncertainty (+/-)							
Power meter		Conducted emission and Power density			Conducted emission		Channel power
Below 1 GHz	Above 1 GHz	Below 1 GHz	1 GHz - 3 GHz	3 GHz - 18 GHz	18 GHz - 26.5 GHz	26.5 GHz - 40 GHz	
0.9 dB	1.0 dB	1.4 dB	1.7 dB	2.8 dB	2.8 dB	2.9 dB	

Test distance	Radiated emission (+dB) 9 kHz - 30 MHz
3m	3.8 dB
10m	3.7 dB

Polarity	Radiated emission (Below 1GHz)			
	(3 m*)(+dB)		(10 m*)(+dB)	
	30 - 200 MHz	200 - 1000MHz	30 - 200 MHz	200 - 1000MHz
Horizontal	4.9 dB	5.2 dB	4.9 dB	5.0 dB
Vertical	4.6 dB	5.9 dB	5.0 dB	5.0 dB

Radiated emission				
(3 m*)(+dB)		(1 m*)(+dB)		(10 m*)(+dB)
1 - 6GHz	6 - 18GHz	10 - 26.5 GHz	26.5 - 40GHz	1 -18 GHz
5.1 dB	5.3 dB	5.1 dB	5.1 dB	5.3 dB

*Measurement distance

Radiated emission test

The data listed in this report meets the limits unless the uncertainty is taken into consideration.

3.5 Test Location

UL Japan, Inc. Ise EMC Lab. *NVLAP Lab. code: 200572-0
 4383-326 Asama-cho, Ise-shi, Mie-ken 516-0021 JAPAN
 Telephone: +81 596 24 8999, Facsimile: +81 596 24 8124

Test site	IC Registration Number	Width x Depth x Height (m)	Size of reference ground plane (m) / horizontal conducting plane	Other rooms	Maximum measurement distance
No.1 semi-anechoic chamber	2973C-1	19.2 x 11.2 x 7.7	7.0 x 6.0	No.1 Power source room	10 m
No.2 semi-anechoic chamber	2973C-2	7.5 x 5.8 x 5.2	4.0 x 4.0	-	3 m
No.3 semi-anechoic chamber	2973C-3	12.0 x 8.5 x 5.9	6.8 x 5.75	No.3 Preparation room	3 m
No.3 shielded room	-	4.0 x 6.0 x 2.7	N/A	-	-
No.4 semi-anechoic chamber	2973C-4	12.0 x 8.5 x 5.9	6.8 x 5.75	No.4 Preparation room	3 m
No.4 shielded room	-	4.0 x 6.0 x 2.7	N/A	-	-
No.5 semi-anechoic chamber	-	6.0 x 6.0 x 3.9	6.0 x 6.0	-	-
No.6 shielded room	-	4.0 x 4.5 x 2.7	4.0 x 4.5	-	-
No.6 measurement room	-	4.75 x 5.4 x 3.0	4.75 x 4.15	-	-
No.7 shielded room	-	4.7 x 7.5 x 2.7	4.7 x 7.5	-	-
No.8 measurement room	-	3.1 x 5.0 x 2.7	N/A	-	-
No.9 measurement room	-	8.8 x 4.6 x 2.8	2.4 x 2.4	-	-
No.11 measurement room	-	6.2 x 4.7 x 3.0	4.8 x 4.6	-	-

3.6 Test data, Test instruments, and Test set up

Refer to APPENDIX.

SECTION 4: Operation of E.U.T. during testing

4.1 Operating Mode(s)

Bluetooth Low Energy (BT LE): Transmitting (Tx)

Details of Operating Mode(s)

Test Item	Operating Mode	Tested Frequency
Spurious Emission	BT LE Tx	2402MHz
6dB Bandwidth		2440MHz
Maximum Peak Output Power		2480MHz
Power Density		
99% Occupied Bandwidth		

Power of the EUT was set by the software as follows;

Power settings : +5dBm

Software: HCI Tester ver 2.3.5.0

*This setting of software is the worst case.

Any conditions under the normal use do not exceed the condition of setting.

In addition, end users cannot change the settings of the output power of the product.

4.2 Configuration and peripherals

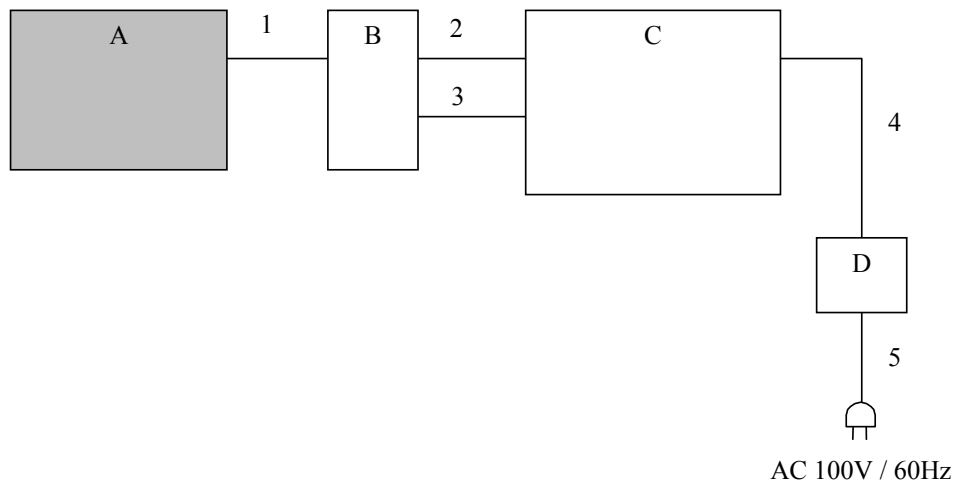

* Cabling and setup(s) were taken into consideration and test data was taken under worse case conditions.

Description of EUT

No.	Item	Model number	Serial number	Manufacturer	Remarks
A	Philips Health Watch	Philips Health Watch	721900215 *1) 439800049 *2)	PHILIPS	EUT
B	Jig	-	-	-	-
C	Laptop PC	CF-N8HWCDPS	-	Panasonic	-
D	AC Adapter	CF-AA6372B	-	Panasonic	-

*1) Used for Conducted Emission test and Radiated Emission test

*2) Used for Antenna Terminal conducted test

List of cables used

No.	Name	Length (m)	Shield		Remarks
			Cable	Connector	
1	Signal Cable	0.2	Unshielded	Unshielded	*1)
2	USB Cable	1.0	Shielded	Shielded	-
3	USB Cable	0.8	Sshielded	Shielded	-
4	DC Power Cable	1.0	Unshielded	Unshielded	-
5	AC Power Cable	0.8	Unshielded	Unshielded	-

*1) Cable No.1 is a cable for Control. This cable is not a part of the product, but it is not removable from the product. Therefore the test was performed with the state which fitted out the cable in the product.

SECTION 5: Radiated Spurious Emission

Test Procedure

It was measured based on "11.0 Emissions in non-restricted frequency bands" of "558074 D01 DTS Meas Guidance v03r05".

[For below 1 GHz]

EUT was placed on a urethane platform of nominal size, 0.5 m by 1.0 m, raised 0.8 m above the conducting ground plane. The Radiated Electric Field Strength has been measured in a Semi Anechoic Chamber with a ground plane.

[For above 1 GHz]

EUT was placed on a urethane platform of nominal size, 0.5 m by 0.5 m, raised 1.5 m above the conducting ground plane.

The Radiated Electric Field Strength has been measured in a Semi Anechoic Chamber with absorbent materials lined on a ground plane.

The height of the measuring antenna varied between 1 and 4 m and EUT was rotated a full revolution in order to obtain the maximum value of the electric field strength.

The measurements were performed for both vertical and horizontal antenna polarization with the Test Receiver, or the Spectrum Analyzer.

The measurements were made with the following detector function of the test receiver and the Spectrum analyzer (in linear mode).

The test was made with the detector (RBW/VBW) in the following table.

When using Spectrum analyzer, the test was made with adjusting span to zero by using peak hold.

Test Antennas are used as below;

Frequency	30 MHz to 200 MHz	200 MHz to 1 GHz	Above 1 GHz
Antenna Type	Biconical	Logperiodic	Horn

In any 100 kHz bandwidth outside the restricted band in which the spread spectrum intentional radiator is operating, the radio frequency power that is produced by the intentional radiator confirmed 20 dB below that in the 100 kHz bandwidth within the band that contains the highest level of the desired power, based on a radiated measurement.

20 dBc was applied to the frequency over the limit of FCC 15.209 / Table 4 of RSS-Gen 8.9(IC) and outside the restricted band of FCC15.205 / Table 6 of RSS-Gen 8.10 (IC).

Frequency	Below 1 GHz	Above 1 GHz		20 dBc
Instrument used	Test Receiver	Spectrum Analyzer		Spectrum Analyzer
Detector	QP	PK	AV *3)	PK
IF Bandwidth	BW 120 kHz	RBW: 1 MHz VBW: 3 MHz	Average Power Method: RBW: 1 MHz VBW: 3 MHz Detector: Power Averaging (RMS) Trace: 100 traces If duty cycle was less than 98%, a duty factor was added to the results. Reduced VBW averaging : RBW: 1 MHz VBW : $\geq 1/T$ Detector: Peak Sweep time: auto Trace mode : max hold	RBW: 100 kHz VBW: 300kHz
Test Distance	3 m	3 m *1) (1 GHz – 10 GHz), 1 m *2) (10 GHz – 26.5 GHz)		3 m *1) (1 GHz – 10 GHz), 1 m *2) (10 GHz – 26.5 GHz)

*1) Distance Factor: $20 \times \log(4.5 \text{ m} / 3.0 \text{ m}) = 3.53 \text{ dB}$

*2) Distance Factor: $20 \times \log(1.0 \text{ m} / 3.0 \text{ m}) = -9.5 \text{ dB}$

*3) Average Power Measurement was performed based on 6.0 & 12.2.5 of "KDB 558074 D01 DTS Meas Guidance v03r05" and 4.1.4.2.3 of "ANSI C63.10-2013"

- The carrier level and noise levels were confirmed at each position of X, Y and Z axes of EUT to see the position of maximum noise, and the test was made at the position that has the maximum noise.

The test results and limit are rounded off to one decimal place, so some differences might be observed.

Measurement range : 30 M - 26.5 GHz
Test data : APPENDIX
Test result : Pass

SECTION 6: Antenna Terminal Conducted Tests

Test Procedure

The tests were made with below setting connected to the antenna port.

Test	Span	RBW	VBW	Sweep time	Detector	Trace	Instrument used
6dB Bandwidth	2 MHz	100 kHz	300 kHz	Auto	Peak	Max Hold	Spectrum Analyzer
99% Occupied Bandwidth *1)	Enough width to display emission skirts	1 to 5 % of OBW	Three times of RBW	Auto	Peak	Max Hold	Spectrum Analyzer
Maximum Peak Output Power	-	-	-	Auto	Peak/ Average *2)	-	Power Meter (Sensor: 50 MHz BW)
Peak Power Density	1.5 times the 6dB Bandwidth	3 kHz	10 kHz	Auto	Peak	Max Hold	Spectrum Analyzer *3)
Conducted Spurious Emission *4)	9kHz to 150kHz	200 Hz	620 Hz	Auto	Peak	Max Hold	Spectrum Analyzer
	150kHz to 30MHz	9.1 kHz	27 kHz				

*1) Peak hold was applied as Worst-case measurement.

*2) Reference data

*3) Section 10.2 Method PKPSD (peak PSD) of "KDB 558074 D01 DTS Meas Guidance v03r05".

*4) In the frequency range below 30MHz, RBW was narrowed to separate the noise contents.

Then, wide-band noise near the limit was checked separately, however the noise was low enough as shown in the chart.
(9 kHz - 150 kHz: RBW = 200 Hz, 150 kHz - 30 MHz: RBW = 9.1 kHz).

The test results and limit are rounded off to two decimals place, so some differences might be observed.

Test data : **APPENDIX**
Test result : **Pass**

UL Japan, Inc.

Ise EMC Lab.

4383-326 Asama-cho, Ise-shi, Mie-ken 516-0021 JAPAN

Telephone : +81 596 24 8999

Facsimile : +81 596 24 8124

APPENDIX 1: Test data

6dB Bandwidth

Test place Ise EMC Lab. No.11 Measurement Room
Report No. 11023664H
Date June 9, 2016
Temperature / Humidity 24 deg. C / 63 % RH
Engineer Yuta Moriya
Mode Tx BT LE

Mode	Frequency [MHz]	6dB Bandwidth [MHz]	Limit [kHz]
BT LE	2402	0.669	> 500
	2440	0.676	> 500
	2480	0.686	> 500

6dB Bandwidth

BT LE

2402 MHz

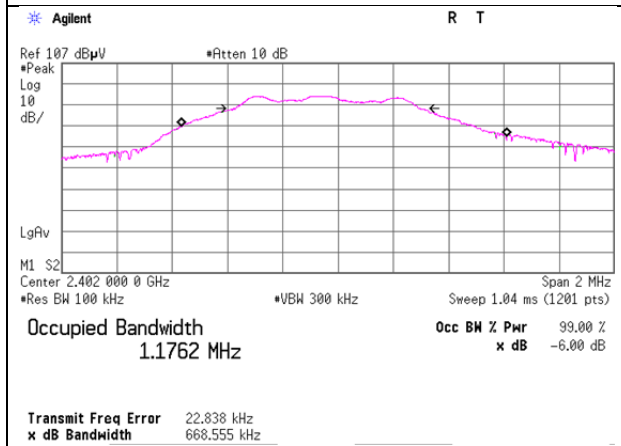

2440 MHz

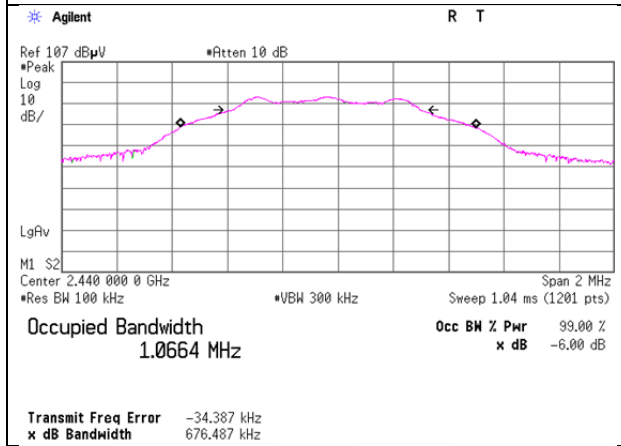

2480 MHz

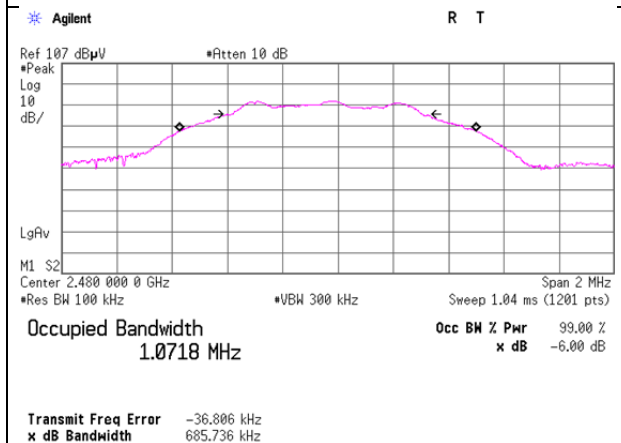

Maximum Peak Output Power

Test place Ise EMC Lab. No.11 Measurement Room
Report No. 11023664H
Date June 9, 2016
Temperature / Humidity 24 deg. C / 63 % RH
Engineer Yuta Moriya
Mode Tx BT LE

BT LE

Freq. [MHz]	Reading [dBm]	Cable Loss [dB]	Atten. Loss [dB]	Result		Limit		Margin [dB]
				[dBm]	[mW]	[dBm]	[mW]	
2402	-15.31	2.44	10.06	-2.81	0.52	30.00	1000	32.81
2440	-16.26	2.45	10.06	-3.75	0.42	30.00	1000	33.75
2480	-17.16	2.45	10.06	-4.65	0.34	30.00	1000	34.65

Sample Calculation:

Result = Reading + Cable Loss (including the cable(s) customer supplied) + Attenuator Loss

Average Output Power
(Reference data for RF Exposure / SAR testing)

Test place : Ise EMC Lab. No.11 Measurement Room
Report No. : 11023664H
Date : June 9, 2016
Temperature / Humidity : 24 deg. C / 63 % RH
Engineer : Yuta Moriya
Mode : Tx BT LE

BT LE

Freq. [MHz]	Reading [dBm]	Cable Loss [dB]	Atten. Loss [dB]	Result (Time average)		Duty factor [dB]	Result (Burst power average)	
				[dBm]	[mW]		[dBm]	[mW]
2402	-17.76	2.44	10.06	-5.26	0.30	1.79	-3.47	0.45
2440	-18.86	2.45	10.06	-6.35	0.23	1.79	-4.56	0.35
2480	-20.07	2.45	10.06	-7.56	0.18	1.79	-5.77	0.26

Sample Calculation:

Result (Time average) = Reading + Cable Loss (including the cable(s) customer supplied) + Attenuator

Result (Burst power average) = Frame power + Duty factor

Burst rate confirmation

Test place	Ise EMC Lab. No.11 Measurement Room
Report No.	11023664H
Date	June 9, 2016
Temperature / Humidity	24 deg. C / 63 % RH
Engineer	Yuta Moriya
Mode	Tx BT LE

BT LE

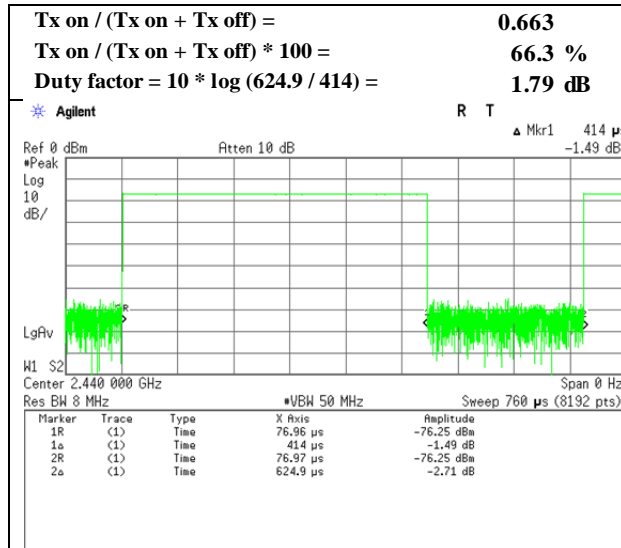

Radiated Spurious Emission

Test place Ise EMC Lab. No.3 Semi Anechoic Chamber
Report No. 11023664H
Date June 13, 2016 June 14, 2016
Temperature / Humidity 22 deg. C / 68 % RH 23 deg. C / 68 % RH
Engineer Takafumi Noguchi Ken Fujita
(Above 1 GHz) (Below 1 GHz)
Mode Tx BT LE 2402 MHz

Polarity	Frequency [MHz]	Detector	Reading [dBuV]	Ant.Fac. [dB/m]	Loss [dB]	Gain [dB]	Duty Factor [dB]	Result [dBuV/m]	Limit [dBuV/m]	Margin [dB]	Remark
Hori	67.432	QP	35.1	6.3	7.6	32.2	-	16.8	40.0	23.2	
Hori	76.550	QP	38.7	5.9	7.7	32.2	-	20.1	40.0	19.9	
Hori	133.737	QP	32.7	13.7	8.4	32.1	-	22.7	43.5	20.8	
Hori	192.955	QP	34.9	16.5	9.0	32.1	-	28.3	43.5	15.2	
Hori	221.900	QP	40.7	11.9	9.2	32.0	-	29.8	46.0	16.2	
Hori	296.400	QP	44.7	13.4	9.8	31.9	-	36.0	46.0	10.0	
Hori	2390.000	PK	46.3	26.7	6.8	32.7	-	47.1	73.9	26.8	
Hori	4804.000	PK	50.8	31.0	9.1	31.8	-	59.1	73.9	14.8	
Hori	7206.000	PK	45.2	35.7	10.3	32.6	-	58.6	73.9	15.3	
Hori	9608.000	PK	42.4	37.2	9.6	33.2	-	56.0	73.9	17.9	Floor noise
Hori	2390.000	AV	33.9	26.7	6.8	32.7	1.8	36.5	53.9	17.4	*1)
Hori	4804.000	AV	45.2	31.0	9.1	31.8	-	53.5	53.9	0.4	*2)
Hori	7206.000	AV	36.5	35.7	10.3	32.6	1.8	51.7	53.9	2.2	
Hori	9608.000	AV	34.3	37.2	9.6	33.2	-	47.9	53.9	6.0	Floor noise
Vert	65.280	QP	43.7	6.6	7.6	32.2	-	25.7	40.0	14.3	
Vert	75.900	QP	41.4	5.9	7.7	32.2	-	22.8	40.0	17.2	
Vert	122.174	QP	32.0	12.8	8.3	32.2	-	20.9	43.5	22.6	
Vert	196.975	QP	27.1	16.7	9.0	32.1	-	20.7	43.5	22.8	
Vert	221.400	QP	39.3	11.9	9.2	32.0	-	28.4	46.0	17.6	
Vert	300.700	QP	45.0	13.5	9.8	31.9	-	36.4	46.0	9.6	
Vert	2390.000	PK	43.9	26.7	6.8	32.7	-	44.7	73.9	29.2	
Vert	4804.000	PK	50.7	31.0	9.1	31.8	-	59.0	73.9	14.9	
Vert	7206.000	PK	44.6	35.7	10.3	32.6	-	58.0	73.9	15.9	
Vert	9608.000	PK	42.4	37.2	9.6	33.2	-	56.0	73.9	17.9	Floor noise
Vert	2390.000	AV	33.5	26.7	6.8	32.7	1.8	36.1	53.9	17.8	*1)
Vert	4804.000	AV	45.0	31.0	9.1	31.8	-	53.3	53.9	0.6	*2)
Vert	7206.000	AV	36.3	35.7	10.3	32.6	1.8	51.5	53.9	2.4	
Vert	9608.000	AV	34.2	37.2	9.6	33.2	-	47.8	53.9	6.1	Floor noise

Result = Reading + Ant Factor + Loss (Cable+Attenuator+Filter+Distance factor(above 1 GHz)) - Gain(Amplifier) + Duty factor

*Other frequency noises omitted in this report were not seen or had enough margin (more than 20 dB).

Distance factor: 1 GHz - 10 GHz 20log(4.5 m / 3.0 m) = 3.53 dB
10 GHz - 26.5 GHz 20log(1.0 m / 3.0 m) = -9.5 dB

*1) Not Out of Band emission(Leakage Power)

*2) It used Reduced VBW averaging across on and off times of the EUT Transmissions with max hold.

20dBc Data Sheet

Polarity	Frequency [MHz]	Detector	Reading [dBuV]	Ant Factor [dB/m]	Loss [dB]	Gain [dB]	Result [dBuV/m]	Limit [dBuV/m]	Margin [dB]	Remark
Hori	2402.000	PK	79.4	26.7	6.8	32.7	80.2	-	-	Carrier
Hori	2400.000	PK	44.8	26.7	6.8	32.7	45.6	60.2	14.6	
Vert	2402.000	PK	76.3	26.7	6.8	32.7	77.1	-	-	Carrier
Vert	2400.000	PK	42.0	26.7	6.8	32.7	42.8	57.1	14.3	

Result = Reading + Ant Factor + Loss (Cable+Attenuator+Filter+Distance factor(above 1 GHz)) - Gain(Amplifier)

Radiated Spurious Emission
(Reference Plot for band-edge)

Test place	Ise EMC Lab. No.3 Semi Anechoic Chamber
Report No.	11023664H
Date	June 13, 2016
Temperature / Humidity	22 deg. C / 68 % RH
Engineer	Takafumi Noguchi (Above 1 GHz)
Mode	Tx BT LE 2402 MHz

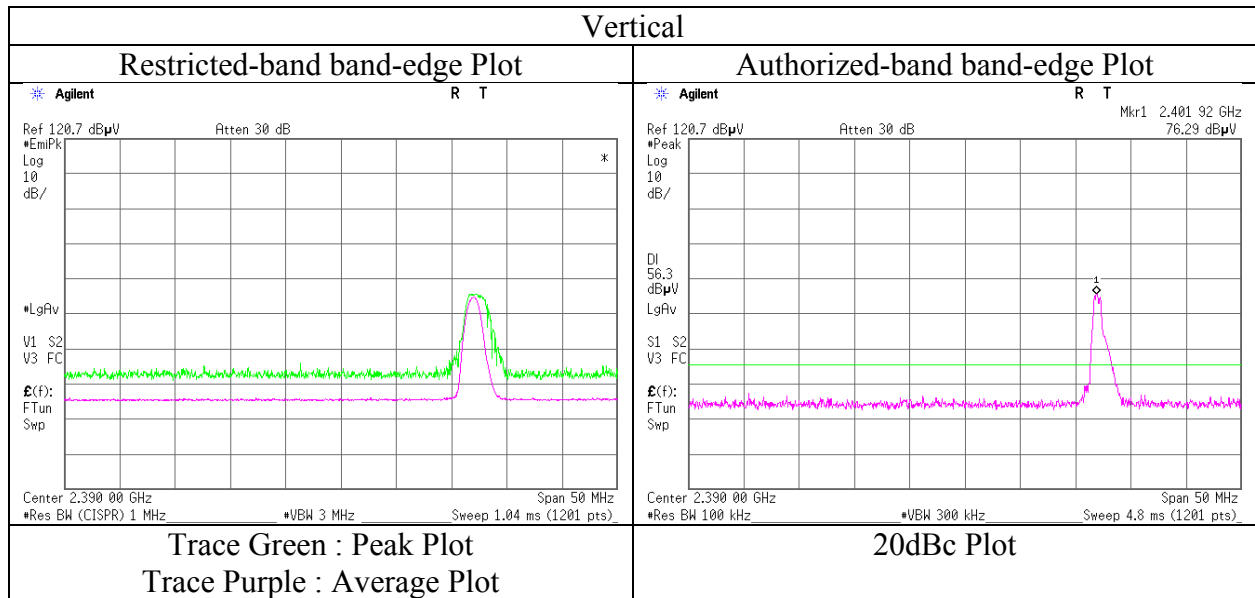
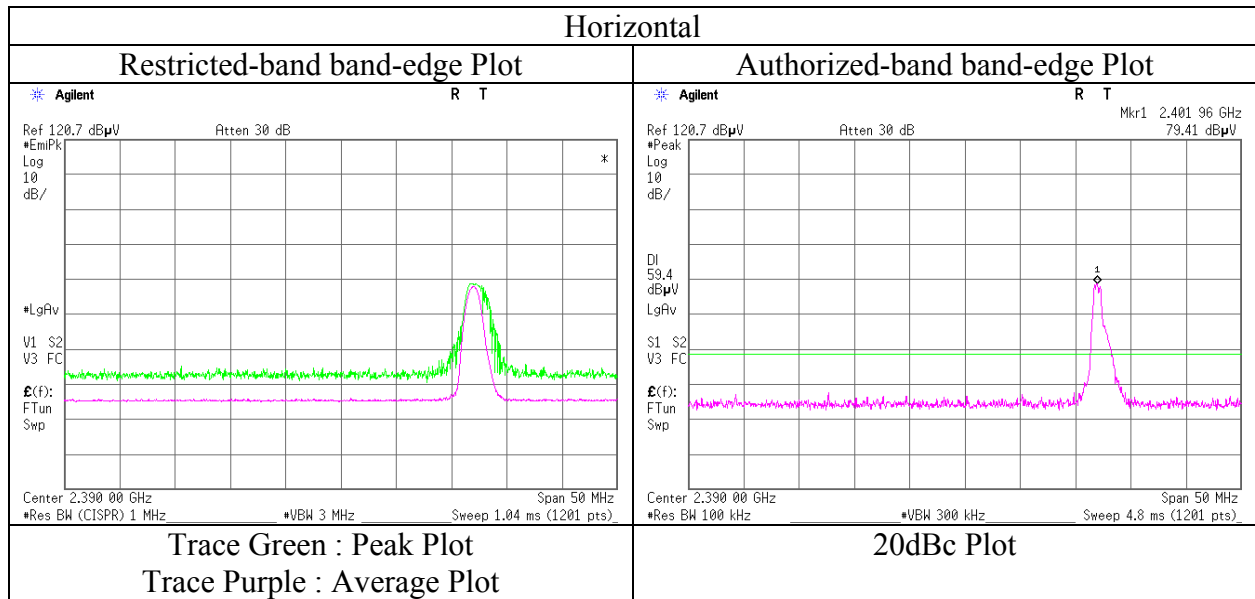

* Final result of restricted band edge was shown in tabular data.

Radiated Spurious Emission

Test place : Ise EMC Lab. No.3 Semi Anechoic Chamber
Report No. : 11023664H
Date : June 13, 2016 June 14, 2016
Temperature / Humidity : 22 deg. C / 68 % RH 23 deg. C / 68 % RH
Engineer : Takafumi Noguchi Ken Fujita
(Above 1 GHz) (Below 1 GHz)
Mode : Tx BT LE 2440 MHz

Polarity	Frequency [MHz]	Detector	Reading [dBuV]	Ant.Fac. [dB/m]	Loss [dB]	Gain [dB]	Duty Factor [dB]	Result [dBuV/m]	Limit [dBuV/m]	Margin [dB]	Remark
Hori	67.456	QP	35.0	6.3	7.6	32.2	-	16.7	40.0	23.3	
Hori	76.500	QP	38.0	5.9	7.7	32.2	-	19.4	40.0	20.6	
Hori	133.737	QP	31.8	13.7	8.4	32.1	-	21.8	43.5	21.7	
Hori	192.865	QP	35.0	16.5	9.0	32.1	-	28.4	43.5	15.1	
Hori	221.905	QP	40.9	11.9	9.2	32.0	-	30.0	46.0	16.0	
Hori	296.400	QP	43.4	13.4	9.8	31.9	-	34.7	46.0	11.3	
Hori	4880.000	PK	48.3	31.3	9.1	31.7	-	57.0	73.9	16.9	
Hori	7320.000	PK	41.7	35.6	8.9	32.6	-	53.6	73.9	20.3	Floor noise
Hori	9760.000	PK	41.8	37.2	9.6	33.3	-	55.3	73.9	18.6	Floor noise
Hori	4880.000	AV	42.1	31.3	9.1	31.7	-	50.8	53.9	3.1	*2)
Hori	7320.000	AV	31.9	35.6	8.9	32.6	-	43.8	53.9	10.1	Floor noise
Hori	9760.000	AV	33.7	37.2	9.6	33.3	-	47.2	53.9	6.7	Floor noise
Vert	65.580	QP	43.9	6.6	7.6	32.2	-	25.9	40.0	14.1	
Vert	75.920	QP	40.9	5.9	7.7	32.2	-	22.3	40.0	17.7	
Vert	122.241	QP	31.0	12.8	8.3	32.2	-	19.9	43.5	23.6	
Vert	196.975	QP	26.9	16.7	9.0	32.1	-	20.5	43.5	23.0	
Vert	221.531	QP	39.1	11.9	9.2	32.0	-	28.2	46.0	17.8	
Vert	300.700	QP	45.2	13.5	9.8	31.9	-	36.6	46.0	9.4	
Vert	4880.000	PK	46.5	31.3	9.1	31.7	-	55.2	73.9	18.7	
Vert	7320.000	PK	40.2	35.6	8.9	32.6	-	52.1	73.9	21.8	Floor noise
Vert	9760.000	PK	41.8	37.2	9.6	33.3	-	55.3	73.9	18.6	Floor noise
Vert	4880.000	AV	39.3	31.3	9.1	31.7	-	48.0	53.9	5.9	*2)
Vert	7320.000	AV	32.0	35.6	8.9	32.6	-	43.9	53.9	10.0	Floor noise
Vert	9760.000	AV	33.8	37.2	9.6	33.3	-	47.3	53.9	6.6	Floor noise

Result = Reading + Ant Factor + Loss (Cable+Attenuator+Filter+Distance factor(above 1 GHz)) - Gain(Amplifier)

*Other frequency noises omitted in this report were not seen or had enough margin (more than 20 dB).

Distance factor: 1 GHz - 10 GHz $20\log(4.5\text{ m} / 3.0\text{ m}) = 3.53\text{ dB}$
 10 GHz - 26.5 GHz $20\log(1.0\text{ m} / 3.0\text{ m}) = -9.5\text{ dB}$

*2) It used Reduced VBW averaging across on and off times of the EUT Transmissions with max hold.

Radiated Spurious Emission

Test place : Ise EMC Lab. No.3 Semi Anechoic Chamber
Report No. : 11023664H
Date : June 13, 2016 June 14, 2016
Temperature / Humidity : 22 deg. C / 68 % RH 23 deg. C / 68 % RH
Engineer : Takafumi Noguchi Ken Fujita
(Above 1 GHz) (Below 1 GHz)
Mode : Tx BT LE 2480 MHz

Polarity	Frequency [MHz]	Detector	Reading [dBuV]	Ant.Fac. [dB/m]	Loss [dB]	Gain [dB]	Duty Factor [dB]	Result [dBuV/m]	Limit [dBuV/m]	Margin [dB]	Remark
Hori	67.321	QP	34.8	6.3	7.6	32.2	-	16.5	40.0	23.5	
Hori	76.511	QP	37.8	5.9	7.7	32.2	-	19.2	40.0	20.8	
Hori	133.721	QP	31.3	13.7	8.4	32.1	-	21.3	43.5	22.2	
Hori	192.888	QP	35.1	16.5	9.0	32.1	-	28.5	43.5	15.0	
Hori	221.915	QP	41.2	11.9	9.2	32.0	-	30.3	46.0	15.7	
Hori	296.400	QP	43.2	13.4	9.8	31.9	-	34.5	46.0	11.5	
Hori	2483.500	PK	47.2	26.8	6.9	32.6	-	48.3	73.9	25.6	
Hori	4960.000	PK	47.3	31.5	9.0	31.7	-	56.1	73.9	17.8	
Hori	7440.000	PK	40.7	35.5	9.0	32.7	-	52.5	73.9	21.4	Floor noise
Hori	9920.000	PK	42.7	37.2	9.7	33.4	-	56.2	73.9	17.7	Floor noise
Hori	2483.500	AV	34.4	26.8	6.9	32.6	1.8	37.3	53.9	16.6	*1)
Hori	4960.000	AV	41.1	31.5	9.0	31.7	-	49.9	53.9	4.0	*2)
Hori	7440.000	AV	32.1	35.5	9.0	32.7	-	43.9	53.9	10.0	Floor noise
Hori	9920.000	AV	34.5	37.2	9.7	33.4	-	48.0	53.9	5.9	Floor noise
Vert	65.560	QP	44.0	6.6	7.6	32.2	-	26.0	40.0	14.0	
Vert	75.897	QP	41.2	5.9	7.7	32.2	-	22.6	40.0	17.4	
Vert	122.221	QP	30.0	12.8	8.3	32.2	-	18.9	43.5	24.6	
Vert	196.962	QP	27.0	16.7	9.0	32.1	-	20.6	43.5	22.9	
Vert	221.551	QP	39.1	11.9	9.2	32.0	-	28.2	46.0	17.8	
Vert	300.301	QP	45.0	13.5	9.8	31.9	-	36.4	46.0	9.6	
Vert	2483.500	PK	47.0	26.8	6.9	32.6	-	48.1	73.9	25.8	
Vert	4960.000	PK	45.8	31.5	9.0	31.7	-	54.6	73.9	19.3	
Vert	7440.000	PK	40.5	35.5	9.0	32.7	-	52.3	73.9	21.6	Floor noise
Vert	9920.000	PK	42.7	37.2	9.7	33.4	-	56.2	73.9	17.7	Floor noise
Vert	2483.500	AV	33.6	26.8	6.9	32.6	1.8	36.5	53.9	17.4	*1)
Vert	4960.000	AV	37.8	31.5	9.0	31.7	-	46.6	53.9	7.3	*2)
Vert	7440.000	AV	32.1	35.5	9.0	32.7	-	43.9	53.9	10.0	Floor noise
Vert	9920.000	AV	34.6	37.2	9.7	33.4	-	48.1	53.9	5.8	Floor noise

Result = Reading + Ant Factor + Loss (Cable+Attenuator+Filter+Distance factor(above 1 GHz)) - Gain(Amplifier) + Duty factor

*Other frequency noises omitted in this report were not seen or had enough margin (more than 20 dB).

Distance factor: 1 GHz - 10 GHz 20log (4.5 m / 3.0 m) = 3.53 dB
 10 GHz - 26.5 GHz 20log (1.0 m / 3.0 m) = -9.5 dB

*1) Not Out of Band emission(Leakage Power)

*2) It used Reduced VBW averaging across on and off times of the EUT Transmissions with max hold.

Radiated Spurious Emission
(Reference Plot for band-edge)

Test place : Ise EMC Lab. No.3 Semi Anechoic Chamber
Report No. : 11023664H
Date : June 13, 2016
Temperature / Humidity : 22 deg. C / 68 % RH
Engineer : Takafumi Noguchi
(Above 1 GHz)
Mode : Tx BT LE 2480 MHz

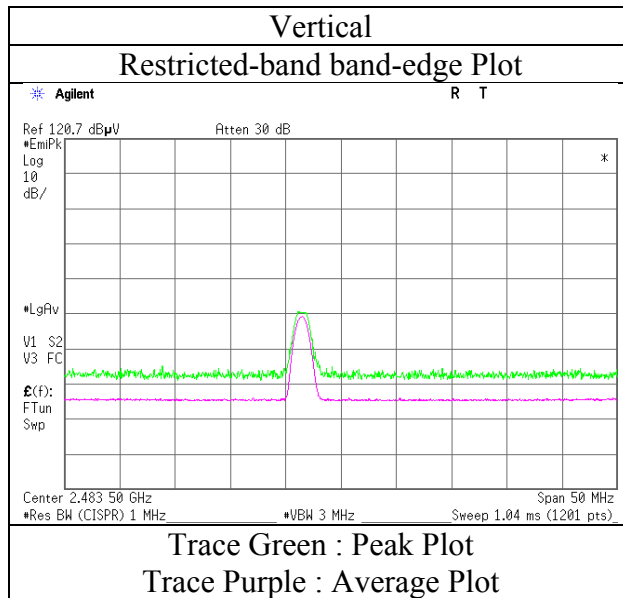
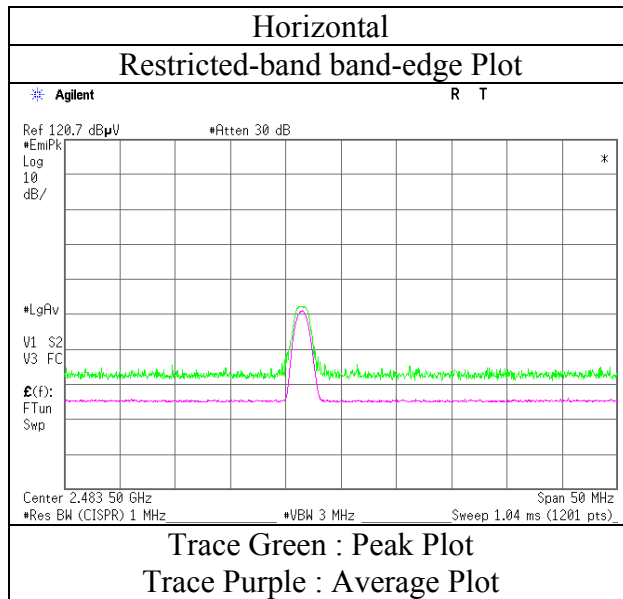

* Final result of restricted band edge was shown in tabular data.

Radiated Spurious Emission (Plot data, Worst case)

Test place	Ise EMC Lab. No.3 Semi Anechoic Chamber	
Report No.	11023664H	
Date	June 13, 2016	June 14, 2016
Temperature / Humidity	22 deg. C / 68 % RH	22 deg. C / 68 % RH
Engineer	Takafumi Noguchi (Above 1 GHz)	Ken Fujita (Below 1 GHz)
Mode	Tx BT LE 2402 MHz	

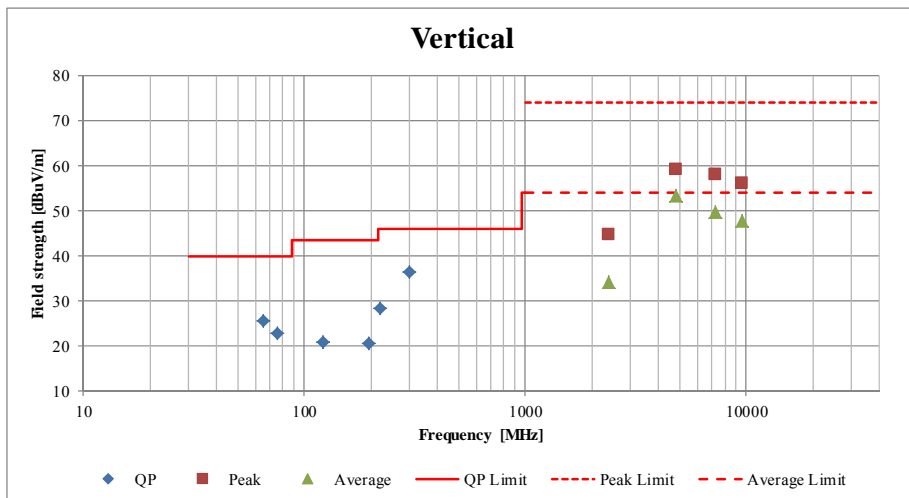
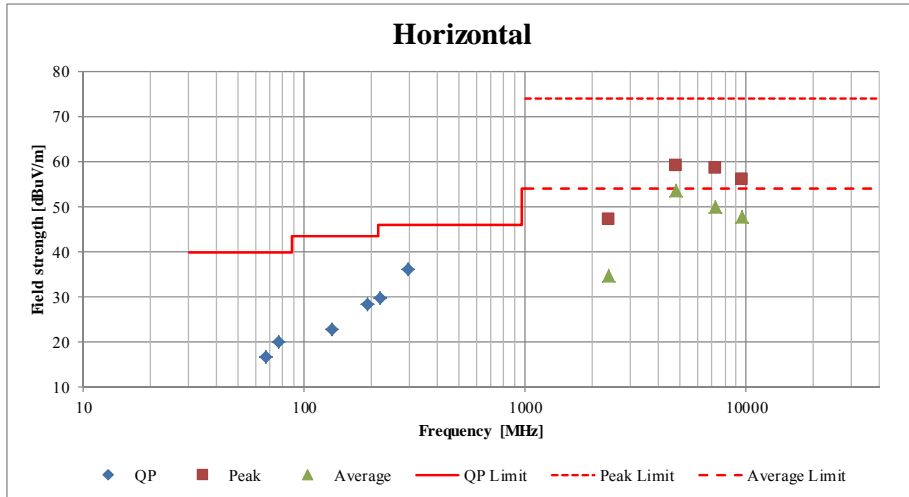

*These plots data contains sufficient number to show the trend of characteristic features for EUT.

Conducted Spurious Emission

Test place	Ise EMC Lab. No.11 Measurement Room
Report No.	11023664H
Date	June 9, 2016
Temperature / Humidity	24 deg. C / 63 % RH
Engineer	Yuta Moriya
Mode	Tx BT LE 2402 MHz

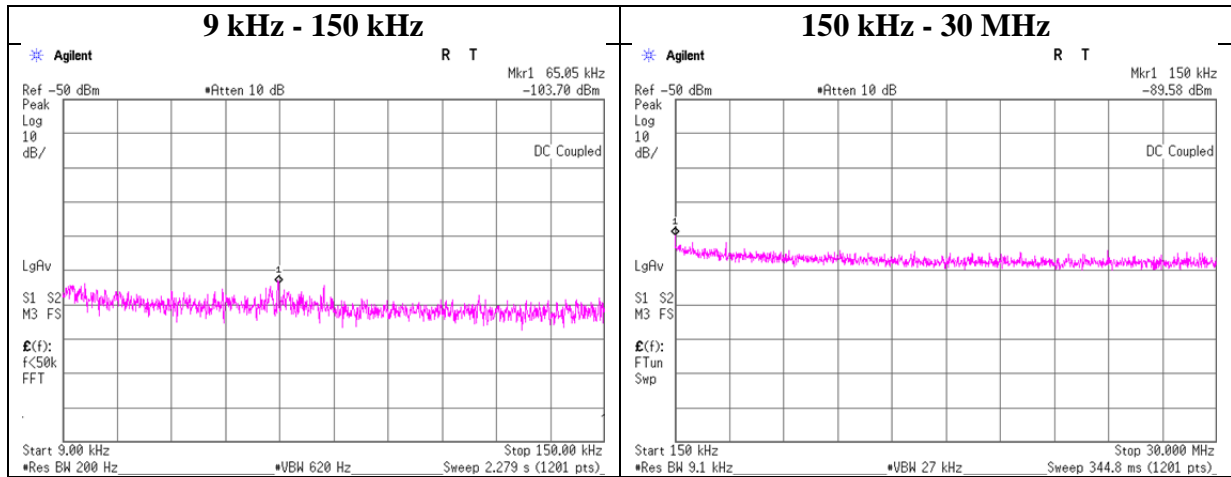

Frequency [kHz]	Reading [dBm]	Cable Loss [dB]	Attenuator Loss [dB]	Antenna Gain [dBi]	N (Number of Output)	EIRP [dBm]	Distance [m]	Ground bounce [dB]	E (field strength) [dBuV/m]	Limit [dBuV/m]	Margin [dB]	Remark
65.05	-103.7	1.50	9.8	2.0	1	-90.4	300	6.0	-29.1	31.3	60.4	
150.00	-89.6	1.51	9.8	2.0	1	-76.2	300	6.0	-15.0	24.0	39.0	

E = EIRP - 20 log (D) + Ground bounce + 104.8 [dBuV/m]

EIRP = Reading + Cable Loss + Attenuator Loss + Antenna Gain + 10 * log (N)

UL Japan, Inc.

Ise EMC Lab.

4383-326 Asama-cho, Ise-shi, Mie-ken 516-0021 JAPAN

Telephone : +81 596 24 8999

Facsimile : +81 596 24 8124

Conducted Spurious Emission

Test place	Ise EMC Lab. No.11 Measurement Room
Report No.	11023664H
Date	June 9, 2016
Temperature / Humidity	24 deg. C / 63 % RH
Engineer	Yuta Moriya
Mode	Tx BT LE 2440 MHz

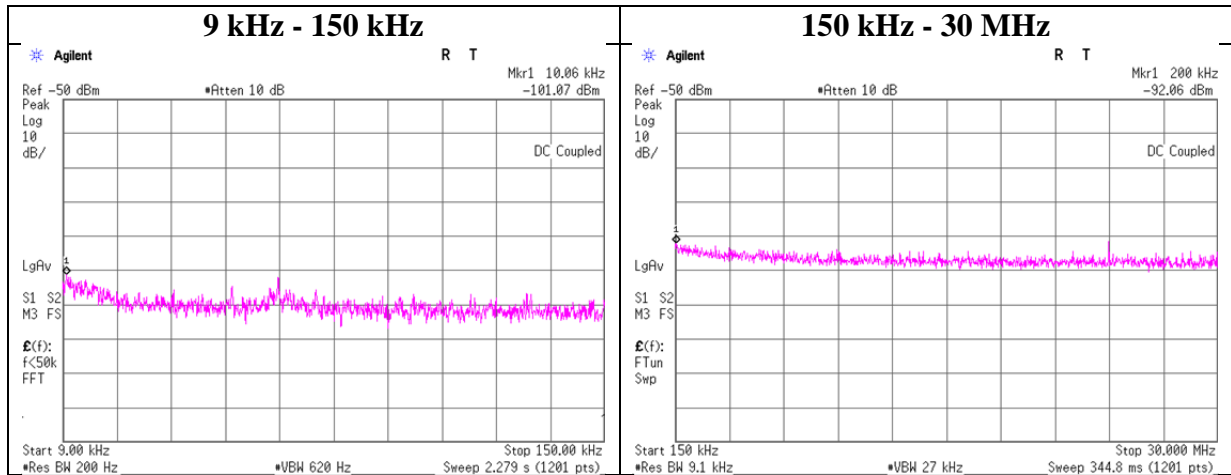

Frequency [kHz]	Reading [dBm]	Cable Loss [dB]	Attenuator Loss [dB]	Antenna Gain [dBi]	N (Number of Output)	EIRP [dBm]	Distance [m]	Ground bounce [dB]	E (field strength) [dBuV/m]	Limit [dBuV/m]	Margin [dB]	Remark
10.06	-101.1	1.51	9.8	2.0	1	-87.7	300	6.0	-26.5	47.5	74.0	
200.00	-92.1	1.51	9.8	2.0	1	-78.7	300	6.0	-17.5	21.5	39.0	

E = EIRP - 20 log (D) + Ground bounce + 104.8 [dBuV/m]

EIRP = Reading + Cable Loss + Attenuator Loss + Antenna Gain + 10 * log (N)

UL Japan, Inc.

Ise EMC Lab.

4383-326 Asama-cho, Ise-shi, Mie-ken 516-0021 JAPAN

Telephone : +81 596 24 8999

Facsimile : +81 596 24 8124

Conducted Spurious Emission

Test place	Ise EMC Lab. No.11 Measurement Room
Report No.	11023664H
Date	June 9, 2016
Temperature / Humidity	24 deg. C / 63 % RH
Engineer	Yuta Moriya
Mode	Tx BT LE 2480 MHz

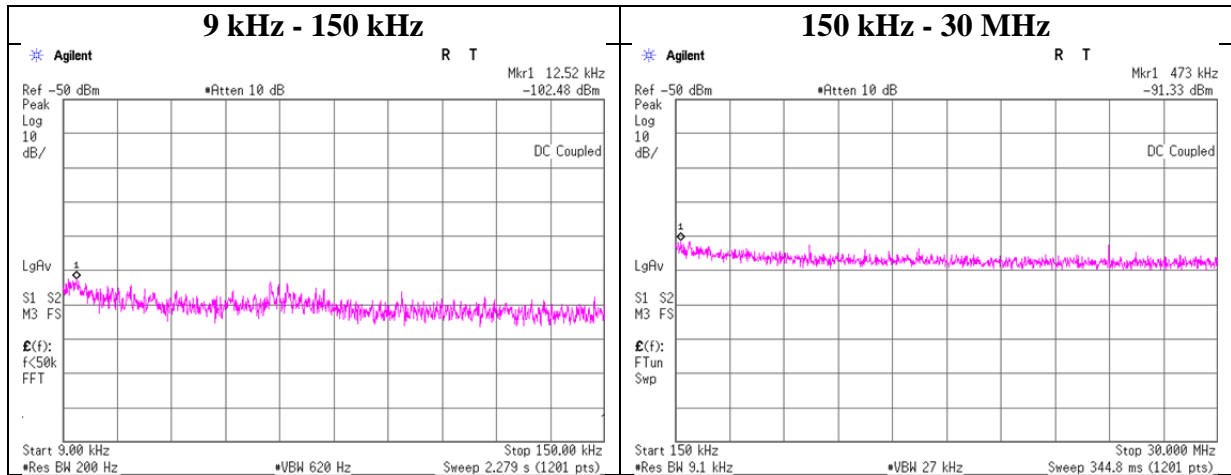

Frequency [kHz]	Reading [dBm]	Cable Loss [dB]	Attenuator Loss [dB]	Antenna Gain [dBi]	N (Number of Output)	EIRP [dBm]	Distance [m]	Ground bounce [dB]	E (field strength) [dBuV/m]	Limit [dBuV/m]	Margin [dB]	Remark
12.52	-102.5	1.51	9.8	2.0	1	-89.2	300	6.0	-27.9	45.6	73.5	
473.00	-91.3	1.51	9.9	2.0	1	-77.9	300	6.0	-16.7	14.1	30.8	

E = EIRP - 20 log (D) + Ground bounce + 104.8 [dBuV/m]

EIRP = Reading + Cable Loss + Attenuator Loss + Antenna Gain + 10 * log (N)

UL Japan, Inc.

Ise EMC Lab.

4383-326 Asama-cho, Ise-shi, Mie-ken 516-0021 JAPAN

Telephone : +81 596 24 8999

Facsimile : +81 596 24 8124

Power Density

Test place Ise EMC Lab. No.11 Measurement Room
Report No. 11023664H
Date June 9, 2016
Temperature / Humidity 24 deg. C / 63 % RH
Engineer Yuta Moriya
Mode Tx BT LE

BT LE

Freq. [MHz]	Reading [dBm]	Cable Loss [dB]	Atten. Loss [dB]	Result [dBm]	Limit [dBm]	Margin [dB]
2402.00	-28.72	2.44	10.06	-16.22	8.00	24.22
2440.00	-32.11	2.45	10.06	-19.60	8.00	27.60
2480.00	-33.67	2.45	10.06	-21.16	8.00	29.16

Sample Calculation:

Result = Reading + Cable Loss (including the cable(s) customer supplied) + Attenuator

Power Density

BT LE

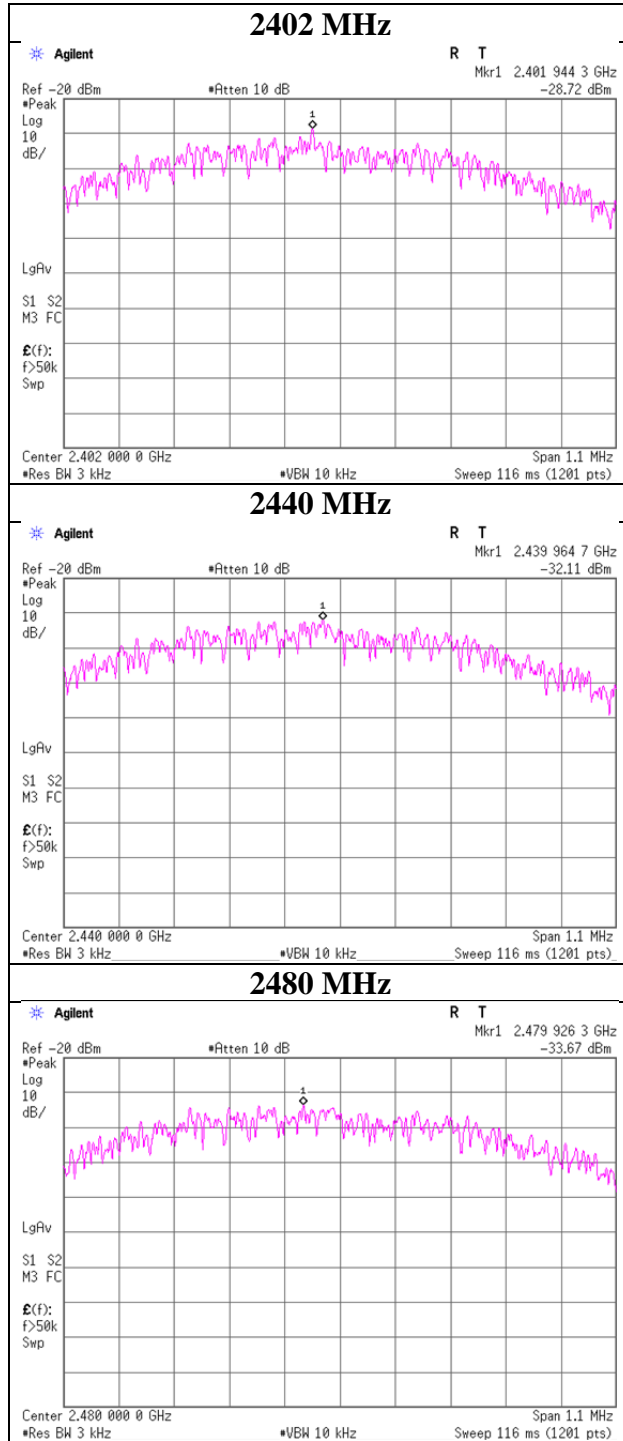

99% Occupied Bandwidth

Test place	Ise EMC Lab. No.11 Measurement Room
Report No.	11023664H
Date	June 9, 2016
Temperature / Humidity	24 deg. C / 63 % RH
Engineer	Yuta Moriya
Mode	Tx BT LE

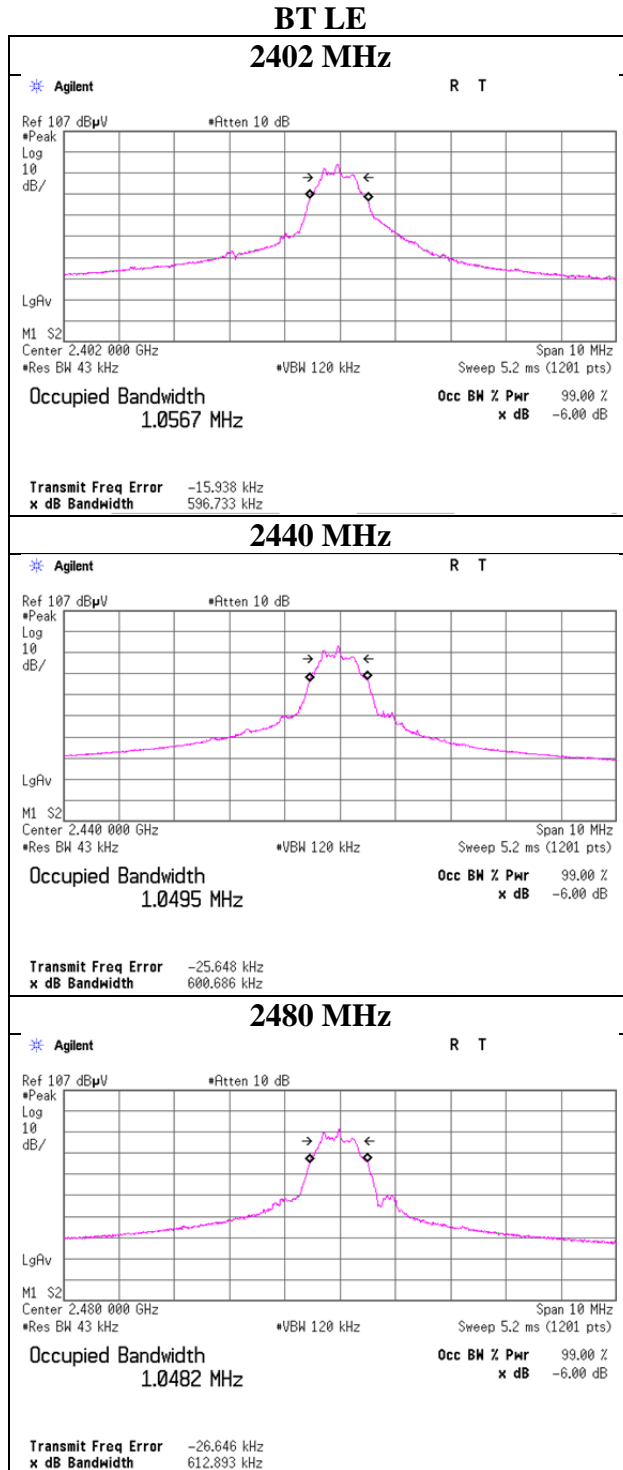

UL Japan, Inc.

Ise EMC Lab.

4383-326 Asama-cho, Ise-shi, Mie-ken 516-0021 JAPAN

Telephone : +81 596 24 8999

Facsimile : +81 596 24 8124

APPENDIX 2: Test instruments

Test equipment

Control No.	Instrument	Manufacturer	Model No	Serial No	Test Item	Calibration Date * Interval(month)
MPM-08	Power Meter	Anritsu	ML2495A	6K00003338	AT	2015/10/08 * 12
MPSE-11	Power sensor	Anritsu	MA2411B	011737	AT	2015/10/08 * 12
MSA-14	Spectrum Analyzer	Agilent	E4440A	MY48250080	AT	2015/10/07 * 12
MCC-144	Microwave Cable	Junkosha	MWX221	1207S407	AT	2015/08/06 * 12
MAT-58	Attenuator(10dB)	Suhner	6810.19.A	-	AT	2016/01/18 * 12
MAT-10	Attenuator(10dB)	Weinschel Corp	2	BL1173	AT	2015/11/10 * 12
MCC-64	Coaxial Cable	UL Japan	-	-	AT	2016/03/10 * 12
MOS-19	Thermo-Hygrometer	Custom	CTH-201	0001	AT	2015/12/08 * 12
MMM-17	DIGITAL HiTESTER	Hioki	3805	070900530	AT	2016/01/13 * 12
MAEC-03	Semi Anechoic Chamber(NSA)	TDK	Semi Anechoic Chamber 3m	DA-10005	RE	2015/10/01 * 12
MOS-13	Thermo-Hygrometer	Custom	CTH-180	1301	RE	2016/01/21 * 12
MJM-16	Measure	KOMELON	KMC-36	-	RE	-
COTS-MEMI	EMI measurement program	TSJ	TEPTO-DV	-	RE	-
MSA-04	Spectrum Analyzer	Agilent	E4448A	US44300523	RE	2015/11/06 * 12
MTR-08	Test Receiver	Rohde & Schwarz	ESCI	100767	RE	2015/09/02 * 12
MBA-03	Biconical Antenna	Schwarzbeck	BBA9106	1915	RE	2015/10/11 * 12
MLA-22	Logperiodic Antenna(200-1000MHz)	Schwarzbeck	VUSLP9111B	911B-191	RE	2016/01/30 * 12
MCC-51	Coaxial cable	UL Japan	-	-	RE	2015/07/13 * 12
MAT-70	Attenuator(6dB)	Agilent	8491A-006	MY52460153	RE	2016/04/05 * 12
MPA-13	Pre Amplifier	SONOMA INSTRUMENT	310	260834	RE	2016/03/24 * 12
MMM-08	DIGITAL HiTESTER	Hioki	3805	051201197	RE	2016/01/13 * 12
MHA-20	Horn Antenna 1-18GHz	Schwarzbeck	BBHA9120D	258	RE	2016/05/29 * 12
MCC-167	Microwave Cable	Junkosha	MWX221	1404S374(1m) / 1405S074(5m)	RE	2016/05/20 * 12
MPA-11	MicroWave System Amplifier	Agilent	83017A	MY39500779	RE	2016/03/24 * 12
MHA-16	Horn Antenna 15-40GHz	Schwarzbeck	BBHA9170	BBHA9170306	RE	2016/05/29 * 12
MHF-06	High Pass Filter 3.5-24GHz	TOKIMEC	TF323DCA	601	RE	2016/05/16 * 12
MHF-25	High Pass Filter 3.5-18.0GHz	UL Japan	HPF SELECTOR	001	RE	2015/09/16 * 12

The expiration date of the calibration is the end of the expired month.

All equipment is calibrated with valid calibrations. Each measurement data is traceable to the national or international standards.

As for some calibrations performed after the tested dates, those test equipment have been controlled by means of an unbroken chains of calibrations.

**Test Item: RE: Radiated Emission test
AT: Antenna Terminal Conducted test**

UL Japan, Inc.

Ise EMC Lab.

4383-326 Asama-cho, Ise-shi, Mie-ken 516-0021 JAPAN

Telephone : +81 596 24 8999

Facsimile : +81 596 24 8124