



HASSELBLAD
CREATE TO INSPIRE

Content

1	Introduction	8
1.1	System Requirements	9
1.2	General Technical Specifications	10
1.3	H6D-50c	11
	Technical Specifications	11
1.4	H6D-100c	12
	Technical Specifications	12
2	Safety	13
2.1	Warnings	14
2.2	Cautions	14
2.3	Disposal	15
2.4	FCC	16
2.5	ISED	16
3	Overview	17
3.1	The H6D Interaction Displays	18
3.2	Main Camera Parts	19
3.3	Parts, Components, Buttons and Controls	20
3.4	Grip Buttons and Controls	23
3.5	Camera Body Buttons and Controls	24
3.6	Sensor Unit	25
3.7	Viewfinder	26
3.8	Lenses	27
3.9	Display Information	28
3.10	Sensor Unit Display and Controls	29
3.11	Grip Display	30
3.12	Viewfinder Display	31
	Typical Viewfinder Display	31
3.13	Re-assignable Grip Buttons Function Options	33
3.14	Short cuts	34
3.15	Phocus Overview	35
3.16	Camera Configuration in Phocus	36
3.17	Battery and Battery Grip	37
3.18	Battery Charger	38
	Charge the Battery	38
	Rechargeable Battery Grip Specification	39
	Battery Life and Battery Warning	40
3.19	Temperature Warning	40
3.20	Power Modes	41
3.21	Automatic Settings	42

3.22	Remove and Attach the Viewfinder	43
3.23	Eyepiece Adjustment	44
3.24	Rubber Eye Cup	44
3.25	Accessory Connection	45
3.26	PC Flash Connector	45
3.27	Protective Baseplate	46
	Remove the Protective Baseplate	46
	Attach the Protective Baseplate	46
3.28	Memory Cards	47
	To Insert a Memory Card	48
	To Remove a Memory Card	49
	Formatting Memory Cards	50
	Format Button	50
	Format Memory Cards via Sensor Unit	50
3.29	Carrying Strap	51
3.30	Remove the Carrying Strap	52
3.31	Change Lens	53
	Attach a Lens	53
	Remove a Lens	53

4 To Prepare 54

4.1	Check the Delivery	55
4.2	Reassign Grip Buttons	56
4.3	Connect to a Computer	57
4.4	Camera Interval Settings	58
4.5	Set Date and Time	59
4.6	Set Language	60
4.7	Set Brightness of the Display	61
4.8	Insert a Memory Card (CFast or SD)	62
4.9	Remove a Memory Card (CFast or SD)	63
4.10	Format a CFast Card	64
	Format Button	64
	Format Memory Cards via Sensor Unit	64
4.11	Set Drive Mode	65

5 To Use 66

5.1	Navigating the Menus	67
	Description of the Sensor Unit Menu Items	67
	Overview of Menus and Settings on Sensor Unit	68
	Touch Screen Navigation	69
5.2	Sensor Unit Display Navigation	70
	Control Screen	70
	Control Screen Description	71
	Add And Remove Favourite Functions to Control Screen	75

5.3	Camera Settings Menu	76
5.4	Camera Exposure Settings	77
	ISO and White Balance	78
	ISO and White Balance on Grip	79
	Exposure Settings Modes	80
	Select Metering / Exposure Setting Modes	80
	Manual Exposure Mode	81
	Automatic Exposure Mode	82
	Automatic Exposure - P and PV Mode	83
	AE-L Button	84
	Fixed Exposure Compensation Setting	85
	Light Meter Exposure Mode	86
	True Exposure	87
	White Balance Settings - Presets and Manual	89
	White Balance Setting by Using a “Grey Card”	90
	Exposure Adjust	91
	Exposure Compensation / Quick Adjust	92
	Flash Settings	93
	Flash and Strobe Settings	94
	Access to Flash Controls	95
	Integral Flash	96
	Separate Flash Unit Connection	97
	Flash Measure of Separate Flash Unit	98
	Exposure Lock	99
	AE-Lock / Quick Adjust	100
	Mirror Settings	101
	Image Orientation	102
5.5	Camera Focus Settings	103
	Focusing Distance Calculation	104
	Stop Down / Depth of Field Preview	104
	Infrared Focus Setting	105
	Focus Assist	106
	Manual Focus	107
	Manual Override in Autofocus Mode	107
	Auto / Manual Focus Setting	107
	Autofocus	108
	Autofocus Check in Manual Mode	108
	Single Shot Focus	109
	Continuous Focus	109
5.6	Camera True Focus	110
	True Focus and Absolute Position Lock	111
	True Focus and Camera Handling	112
	Focus Checking	112

5.7	Camera True Focus Methods	113
	Activated By Shutter Release - True Focus Retained	113
	Temporarily Activated - Autofocus Retained	114
	Activated by True Focus - Autofocus Deactivated	115
	Activated by an Assigned Button - Manual Focus Retained	116
5.8	Camera Self Timer	117
5.9	Camera Interval Settings	118
5.10	Camera Bracketing Settings	119
	Bracketing Function	119
5.11	Camera Live View Settings	120
	Live View	121
	Zooming in Live View	121
	Focus in Live View	121
	Live View with HDMI External Screen	122
5.12	Camera Controls Settings	123
5.13	Video Settings Menu	124
	Video Settings	124
5.14	Video Quality Settings	125
	Video Quality Settings	125
5.15	Video Recording	126
5.16	General Settings Menu	127
	General Settings WI-FI	128
5.17	General Settings Display	129
5.18	General Settings Storage	130
	Format CFast and SD cards	131
	Format Button	131
	Format Memory Cards via Sensor Unit	131
	Image and Video Destination	132
5.19	General Settings Date and Time	133
5.20	General Settings Power and Timeouts	134
	Set Display Off Mode	135
	Power Off	135
5.21	General Settings Language	136
5.22	General Settings Service	137
5.23	General Settings Check for Update	138
5.24	General Settings About	139
5.25	Grip Display Navigation	140
	Buttons and Controls on Grip Display	140
	To Adjust Shutter and Aperture on Grip	141
	Grip Display Navigation	142
5.26	Viewfinder Display Navigation	145
	Typical Viewfinder Display	145
	Viewfinder Display Navigation Overview	146
	Viewfinder Display Examples	147

5.27	Remove / Attach Viewfinder	150
	Remove the Viewfinder	150
	Attach the Viewfinder	150
	Adjust the Eyepiece	151
	Change Focusing Screen	152
5.28	Preview, Histogram and Browsing	153
	Preview Modes	153
	Standard Preview	154
	9 View Mode	154
	Histogram Types	155
	Histogram Mode	155
	Capture Details Mode	155
	Luminance Histogram Mode	155
	Separate Histogram RBG Mode	155
	Histogram Mode - Exposure	156
	Browsing	157
	Zoom in and out	158
5.29	Phocus	159
	Features in Phocus	159
	Phocus Mobile	159
	Phocus and Hasselblad Capture Files	160
5.30	Lenses and Focus Modes	161
	Remove the Lens	161
	Attach the Lens	162
	Remove the Lens Cap	163
	Attach the Lens Cap	163
	Remove the Lens Shade	164
	Attach the Lens Shade	164
	Filters	165
	To Set Focus Distance	166
5.31	Battery	167
	Charge the Battery	167
	Check the Battery Status	168
5.32	Protective Baseplate	169
	Remove the Protective Baseplate	169
	Attach the Protective Baseplate	169

5.33	Store the Camera	170
------	------------------	-----

6 Accessories 171

6.1	Accessories Connectivity Diagram	172
6.2	HC Lens Range	173
6.3	Optional HC Lens Accessories	174
	HTS 1.5	174
	CF Adapter	174
	H 13, 26 and 52 Extension tubes	174
	Converter H 1.7X	174
	Macro Converter H	174
6.4	Optional Accessories	175
	HVM waist level viewfinder	175
	Pro shade V/H 60 – 95	175
	Pro shade adapters	175
	GIL (Global Image Locator)	175
	Tripod quick coupling H	175
	Flash adapter SCA 3902	176
	UV-sky filters	176
	Pola filters	176
	Support strap with Quick plate H	176
	Camera strap H	176
	Focusing screens	176
	Release cord H	177
	HVM correction lens holder	177
	HVD 90x / HV 90x & 90x-II viewfinders	177
	Angle finder H	177
	DC power grip	177
6.5	HM 16-32 Film Magazine	178

7 Troubleshooting 186

7.1	Error Messages	188
7.2	Change Language on Sensor Unit from Unknown Language	189
7.3	Clean the Lens Glass	190
	Remove Dust	190
	Remove Smear	190
7.4	Clean the Sensor Unit Filter	191

1.1 SYSTEM REQUIREMENTS

Storage and editing of images requires a certain minimum standard regarding computer capabilities. Large images require a reasonably high-performance computer with sufficient memory, advanced graphics capabilities and a recent operating system.

It is recommended that the computer has a USB 3 connector, which will allow you to load images more quickly from the camera.

A USB CFast card and SD card reader can also be used for image transfer from the CFast and SD cards.

1.2 GENERAL TECHNICAL SPECIFICATIONS

Camera Type	Medium Format Digital SLR camera with Auto-focus, Auto-exposure, interchangeable Viewfinders and Lenses.
Construction	One piece stainless steel shell. Die-cast aluminium internal structure. Tripod sockets (1/4 and 3/8") and quick coupling tripod plate for rapid mounting.
Lenses	Hasselblad HC/HCD lenses with built-in electronically controlled shutter and aperture. Automatic or manual focusing with instant manual focus override. All HC/HCD lenses meet the exacting requirements of digital photography. Lens shades can be mounted in reverse for transport. V- system lenses can be used with a CF adapter.
Lens factor	HC – 1.0 / HCD –1.0.
Viewfinder (HV 90x-II for 100c with 2.7 times magnification and HVD 90x for 50c 3.1 times magnification)	A 90° reflex viewfinder, providing 100% field of view even when wearing eyeglasses, and built-in multi-mode light metering system. Image magnification 3.1x. Integrated fill-in flash with guide number 12. Hot-shoe for automatic flash (Metz SCA3002 system / adapter SCA3902). Dot matrix display with presentation of all relevant information. Built-in diopter adjustment from -5 to + 3.5D. Interchangeable.
Focusing	Automatic and manual focusing with electronic focus aid in manual mode. Instant manual focus override. Automatic focusing using passive central cross type phase detection sensor. AF metering range EV 1 to 19 (ISO 100).
Shutter	Electronically controlled lens shutter with speeds up to 1/1000. Flash sync at all speeds.
Flash control	TTL centre-weighted system. Can be used with the built-in flash or a wide variety of flashes compatible with the SCA3002 (Metz) system using adapter SCA3902. ISO range 16 to 6400. Flash output can be adjusted (-3 to +3EV) for fill-in purposes independent of ambient light. Synch at all shutter speeds.
Flash measurement	The H6D has a built-in measurement system that measures flash light from non-TTL flashes, such as studio flashes.
Exposure metering	Multi-mode exposure metering using 90° reflex viewfinder. Metering options are: Spot (diameter 7.5 mm), Centre Weighted, and CentreSpot. Metering range at f/2.8 and ISO100: Spot: EV2 to 21, Centre-weighted: EV1 to 21, CentreSpot: EV1 to 21.
Auto bracketing	Bracketing using predetermined number of captures (2, 3, 5, 7 or 9) in 1/3, 1/2, or 1 EV step difference intervals.
Interval timer	Number of captures from 2 to 'no limit' and interval from 1 second to 1 hour.
ISO range	ISO range: H6D-50c ISO 100 - 6400. H6D-100c 64 - 12800.
Displays	The camera features two dot-matrix displays that provide clear and easy-to-understand information to the user. One is located on the grip and the other in the 90° viewfinder. The sensor unit has a high resolution full touch 3 inch TFT display.
Focusing screen	Bright Spherical Acute-Matte type D with sensor format markings. Grid marked type also available as option.
Compatibility	All H System lenses and accessories except film magazines. V system C type lenses with optional CF lens adapter.
Accessory connection	Provided with two M5 threads and an electrical connector for accessories.
Customization	A large number of the H6D's functions can be customized by the user to suit specific styles or situations through the built-in menu system.
User interface	Full touch user interface, including swipe, scroll and pinch/spread to zoom. Camera grip with buttons and control wheels. Many camera functions and settings can be controlled from a tethered computer or iPhone/iPad over Wi-Fi.
Rechargeable battery grip Li-ion	3200 mAh output.

1.3 H6D-50C

TECHNICAL SPECIFICATIONS

Sensor type	CMOS, 50 megapixels (8272 × 6200 pixels, 5.3 × 5.3 µm)
Sensor dimensions	43.8 × 32.9mm
Image size	Stills: RAW 3FR capture 65MB on average. TIFF 8 bit: 154MB; Video: HD (1920 x 1080p)
File format	Stills: Hasselblad 3FR Video: H.264 Compressed (25 fps)
Shooting mode	Single shot stills, Video
Colour definition	16 bit; Dynamic range approx. 14 stops
ISO speed range	ISO 100, 200, 400, 800, 1600, 3200, 6400
Storage options	CFast card, SD card or tethered to Mac or PC
Colour management	Hasselblad Natural Colour Solution, HNCS
Storage capacity	16GB card holds 240 images on average
Capture rate	TBD
Display	3 inch TFT type, 24 bit colour, 920K pixels; Touch functionality: Yes, full support Live View: On camera, host and iOS device with high frame rate
Histogram feedback	Yes, on Sensor Unit Display
IR filter	Mounted in front of sensor
Software	Phocus for Mac and Windows
Platform support	Macintosh: OSX version 10.9; PC: XP/Vista/Windows 7 (32 and 64 bit)/ 8 / 10
Host connection type	USB 3.0 (5 Gbit/s) Type-C connector, Mini HDMI, Audio In/Out
Additional connections	Mini HDMI, Audio In/Out, Flash sync In/Out, Power In
View camera compatibility	Yes, Mechanical shutters controlled via flash sync. Electronic shutters can be controlled from Phocus
Operating temperature	-10 - 45 °C / 14 - 113 °F
Wi-Fi	802.11 a, b, g, n (depending on region), ac
Dimensions	Complete camera w/ HC80 lens: 153 x 131 x 205mm [W x H x D]
Weight	2105g (Complete camera w/ HC80 lens, Li-Ion battery and card)
Camera type	Large sensor medium format DSLR
Lenses	Hasselblad H system lens line with integral central lens shutter
Shutter speed range	60 minutes to 1/2000 sec (depending on lens type used)
Flash sync speed	Flash can be used at all shutter speeds
Viewfinder options	HVD 90x: 90° eye-level viewfinder w. dioptre adjustment (-5 to +3.5D). Image magnification 3.1x. Integral fill-flash (GN. 12 @ ISO100). Hot shoe for SCA3002-system flashes from Metz™ HV 90x II: 90° eye-level viewfinder w. dioptre adjustment (-4 to +2.5D). Image magnification 2.7x. Integral fill-flash (GN. 12 @ ISO100). Hot shoe for SCA3002-system flashes from Metz™ HVM: Waist-level viewfinder. Image magnification 3.2x
Focusing	Autofocus metering with passive central cross-type sensor. Ultra focus digital feedback. Instant manual focus override. Metering range EV 1 to 19 at ISO 100
Flash control	Automatic TTL centre weighted system. Uses built-in flash or flashes compatible with SCA3002 (Metz™). Output can be adjusted from -3 to +3EV. For manual flashes a built-in metering system is available
Exposure metering	Spot, Center Weighted and Center Spot Metering range Spot: EV2 to 21, Center Weighted: EV1 to 21, Center Spot: EV1 to 21
Power supply	Rechargeable Li-ion battery (7.2 VDC/3200 mAh); Socket for external power
Film compatibility	Yes

1.4 H6D-100C

TECHNICAL SPECIFICATIONS

Sensor type	CMOS, 100 megapixels (11600 × 8700 pixels, 4.6 × 4.6 µm)
Sensor dimensions	53.4 × 40.0mm
Image size	Stills: RAW 3FR capture 120MB on average. TIFF 8 bit: 289MB; Video: HD (1920 x 1080p), UHD (3840 x 2160p)
File format	Stills: Hasselblad 3FR Video: Hasselblad RAW (UHD, 30 fps)
Shooting mode	Single shot stills, Video
Colour definition	16 bit; Dynamic range 15 stops
ISO speed range	ISO TBD: 64, 100, 200, 400, 800, 1600, 3200, 6400, 12800
Storage options	CFast card, SD card or tethered to Mac or PC
Colour management	Hasselblad Natural Colour Solution, HNCS
Storage capacity	16GB card holds 120 images on average
Capture rate	TBD
Display	3 inch TFT type, 24 bit colour, 920K pixels; Touch functionality: Yes, full support Live View: On camera, host and iOS device with high frame rate (30 fps)
Histogram feedback	Yes (on rear display and on camera grip display)
IR filter	Mounted in front of sensor
Software	Phocus for Mac and Windows
Platform support	Macintosh: OSX version 10.9; PC: XP/Vista/Windows 7 (32 and 64 bit)/ 8 / 10
Host connection type	USB 3.0 (5 Gbit/s) Type-C connector, Mini HDMI, Audio In/Out
Additional connections	Mini HDMI, Audio In/Out, Flash sync In/Out, Power In
View camera compatibility	Yes, Mechanical shutters controlled via flash sync. Electronic shutters can be controlled from Phocus
Operating temperature	-10 - 45 °C / 14 - 113 °F
Wi-Fi	802.11 a, b, g, n (depending on region), ac
Dimensions	Complete camera w/ HC80 lens: 153 x 131 x 205mm [W x H x D]
Weight	2105g (Complete camera w/ HC80 lens, Li-Ion battery and card)
Camera type	Large sensor medium format DSLR
Lenses	Hasselblad H system lens line with integral central lens shutter
Shutter speed range	60 minutes to 1/2000 sec (depending on lens type used)
Flash sync speed	Flash can be used at all shutter speeds
Viewfinder options	HVD 90x: 90° eye-level viewfinder w. dioptre adjustment (-5 to +3.5D). Image magnification 3.1x. Integral fill-flash (GN. 12 @ ISO100). Hot shoe for SCA3002-system flashes from Metz™ HV 90x II: 90° eye-level viewfinder w. dioptre adjustment (-4 to +2.5D). Image magnification 2.7x. Integral fill-flash (GN. 12 @ ISO100). Hot shoe for SCA3002-system flashes from Metz™ HVM: Waist-level viewfinder. Image magnification 3.2x
Focusing	Autofocus metering with passive central cross-type sensor. Ultra focus digital feedback. Instant manual focus override. Metering range EV 1 to 19 at ISO 100
Flash control	Automatic TTL centre weighted system. Uses built-in flash or flashes compatible with SCA3002 (Metz™). Output can be adjusted from -3 to +3EV. For manual flashes a built-in metering system is available
Exposure metering	Spot, Centre Weighted and CentreSpot Metering range Spot: EV2 to 21, Centre Weighted: EV1 to 21, CentreSpot: EV1 to 21
Power supply	Rechargeable Li-ion battery (7.2 VDC/3200 mAh); Socket for external power
Film compatibility	Yes

2.1 WARNINGS

Warning!

Do not place cables between camera and computer so that there is a risk for people to trip and fall. This can cause personal injury and/or damage to the equipment.

Warning!

If you use spare battery packs, make sure to use protective caps on the contacts. The contacts can short-circuit and catch fire if not protected. This can cause personal injury and/or damage to the equipment.

Warning!

Do not expose batteries (battery pack and batteries installed) to excessive heat such as sunshine, fire or similar. If exposed, the batteries can catch fire. This can cause personal injury, damage to the equipment and the surrounding environment.

Warning!

Be careful when working with strobe and flash units. This will prevent personal injury and/or damage to the equipment.

2.2 CAUTIONS

Caution!

Be careful when you use the camera. The camera is a precision instrument. This will help prevent damage to the camera.

Caution!

Danger of explosion if battery is incorrectly replaced. Replace only with the same or equivalent type.

Caution!

Do not use batteries other than specified. This can cause damage to the batteries.

Caution!

Use protective covers as much as possible. The protective covers will help prevent damage to the equipment.

Caution!

Use a protective case or camera bag when you transport the equipment. This will help prevent damage to the equipment.

Caution!

Protect the equipment from oil fumes, steam, humid conditions and dust. This will help prevent damage to the equipment.

Caution!

Seal all equipment in a plastic bag or similar if you enter damp

and humid condition from dry and cold condition. Wait until the equipment has acclimatized to the new temperature before you remove the equipment from bag. This will help prevent damage to the equipment.

Caution!

Avoid frequent and high temperature changes. This can cause damage to the equipment.

Caution!

Keep camera and equipment away from moisture. If your camera becomes wet, disconnect from electric power and let camera dry before further use. This will help prevent damage to the equipment.

Caution!

Store the equipment in a dry environment. This will help prevent damage to the equipment.

Caution!

Be careful when you attach/detach the components to/from the camera. This will help prevent damage to the data bus connections.

Caution!

Use the grip or strap when you lift and handle to camera. This will help prevent damage to the camera.

Caution!

Do not insert fingers into the camera body. This can cause damage to the equipment.

Caution!

Do not touch the glass surface with your fingers. This can cause damage to the equipment.

Caution!

Do not touch the CMOS/Sensor with your fingers. This can cause damage to the equipment.

Caution!

When you remove the sensor unit, keep foreign objects away from the camera opening. The camera opening is very sensitive. This will help prevent damage to the equipment.

Caution!

When you remove the sensor unit, make sure to be careful with the CMOS sensor protective filter. The CMOS sensor protective filter is very sensitive. This will help prevent damage to the equipment.

Safety

Caution!

Keep all equipment out of reach of small children. This will prevent damage to the equipment.

Caution!

When cleaning the camera, remove the batteries. This will prevent damage to the camera.

Caution!

If you leave the camera unused for a long period, remove the batteries. This will prevent damage to the equipment.

Caution!

Do not open the sensor unit. This can cause damage to the sensor unit.

Caution!

Do not cover the ventilation openings on the sensor unit. It can overheat and cause damage to the equipment.

Caution!

Before you connect the sensor unit to camera after storage, always replace the protective CMOS/filter cover. This will prevent damage to the equipment.

Caution!

Do not try to remove the glass IR filter from the front of the CMOS (due to dust or similar). This can cause damage to the equipment. Always contact your local Hasselblad Authorized Service Center.

Caution!

If you use canned compressed air to clean the glass of IR filter, read the instructions very carefully before use. This will help prevent damage to the filter.

2.3 DISPOSAL



This product must be put in municipal waste.
Check local regulations for disposal.

2.4 FCC

Federal Communication Commission Interference Statement:

This equipment has been tested and found to comply with the limits for a Class B digital device, pursuant to Part 15 of the FCC Rules. These limits are designed to provide reasonable protection against harmful interference in a residential installation.

This equipment generates, uses and can radiate radio frequency energy and, if not installed and used in accordance with the instructions, may cause harmful interference to radio communications. However, there is no guarantee that interference will not occur in a particular installation. If this equipment does cause harmful interference to radio or television reception, which can be determined by turning the equipment off and on, the user is encouraged to try to correct the interference by one of the following measures:

- Reorient or relocate the receiving antenna.
- Increase the separation between the equipment and receiver.
- Connect the equipment into an outlet on a circuit different from that to which the receiver is connected.
- Consult the dealer or an experienced radio/TV technician for help.

FCC Caution: Any changes or modifications not expressly approved by the party responsible for compliance could void the user's authority to operate this equipment.

This device complies with Part 15 of the FCC Rules. Operation is subject to the following two conditions:

1. This device may not cause harmful interference, and
2. this device must accept any interference received, including interference that may cause undesired operation.

FCC Radiation Exposure Statement:

This equipment complies with FCC radiation exposure limits set forth for an uncontrolled environment. The highest SAR value as reported to the authorities for the H6D-50c when tested for use by the Body is 0.024W/kg against a limit of 1.6W/kg.

2.5 ISED

RSS-Gen Information for the Certification of Radio Apparatus

This device complies with ISED licence-exempt RSS standard(s). Operation is subject to the following two conditions:

1. this device may not cause interference, and
2. this device must accept any interference, including interference that may cause undesired operation of the device.

Cet appareil est conforme au(x) standard(s) RSS exempt(s) de licence de ISED. Son fonctionnement est sujet aux deux conditions suivantes:

1. cet appareil ne doit pas occasionner d'interférence
2. cet appareil doit supporter toutes les interférences, y compris celles qui pourraient provoquer un mauvais fonctionnement de cet appareil.

RSS-102 RF Exposure Compliance of Radiocommunication Apparatus

The H6D-50c has been designed to comply with safety requirements for exposure to radio waves. SAR testing has been performed in accordance with RSS-102, with the H6D-50c transmitting at its highest certified power level in all used frequency bands. The highest SAR value for the H6D-50c when tested was 0.024W/kg against a limit of 1.6W/kg.

Please follow the instructions included in the user guide for product installation and use.

Le H6D-50c a été conçu pour se conformer aux exigences de sécurité en matière d'exposition aux ondes radio. Des tests SAR ont été effectués conformément à la RSS-102 avec le H6D-50c transmettant à son plus haut niveau de puissance certifié dans toutes les bandes de fréquences utilisées.

La valeur SAR la plus élevée pour la H6D-50c lors des tests était de 0,024 W / Kg contre une limite de 1.6W / Kg.

Merci de suivre les instructions fournies dans le mode d'emploi pour l'installation et l'utilisation du produit.

3.1 THE H6D INTERACTION DISPLAYS



Viewfinder Display

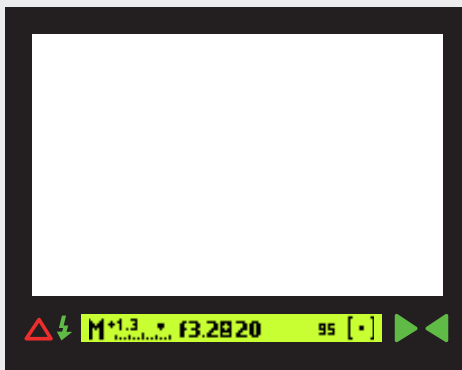

Sensor Unit Display

This display is touch sensitive and you can use it in the same way you navigate on a smart phone. Swipe, select, pinch and spread to zoom for example. You can also navigate by using the 5 soft buttons under the display and scroll wheels on the Camera Grip.

Grip Display and Viewfinder Display

Press the WB, AF, ISO, Menu, Play or Profile buttons near the Grip display. The + / - and EXP buttons on the side of the Viewfinder are part of the Grip interaction. Change settings by scrolling the Front Scroll Wheel or the Rear Scroll Wheel. Press the same button again to Exit and Save.

Sensor Unit Display



Grip Display



3.2 MAIN CAMERA PARTS



3.3 PARTS, COMPONENTS, BUTTONS AND CONTROLS

All items mentioned on this page are described in greater detail elsewhere in this manual.

- 1 Focus assist illuminator
- 2 Mirror Up button
- 3 Remote release port
- 4 Stop Down button
- 5 Battery grip



- 1 True Focus button
- 2 Card Format button
- 3 AE-L button
- 4 Camera strap holder
- 5 Grip lever release button
- 6 Battery grip locking lever

- 1 Speaker
- 2 Product number
- 3 Sensor unit



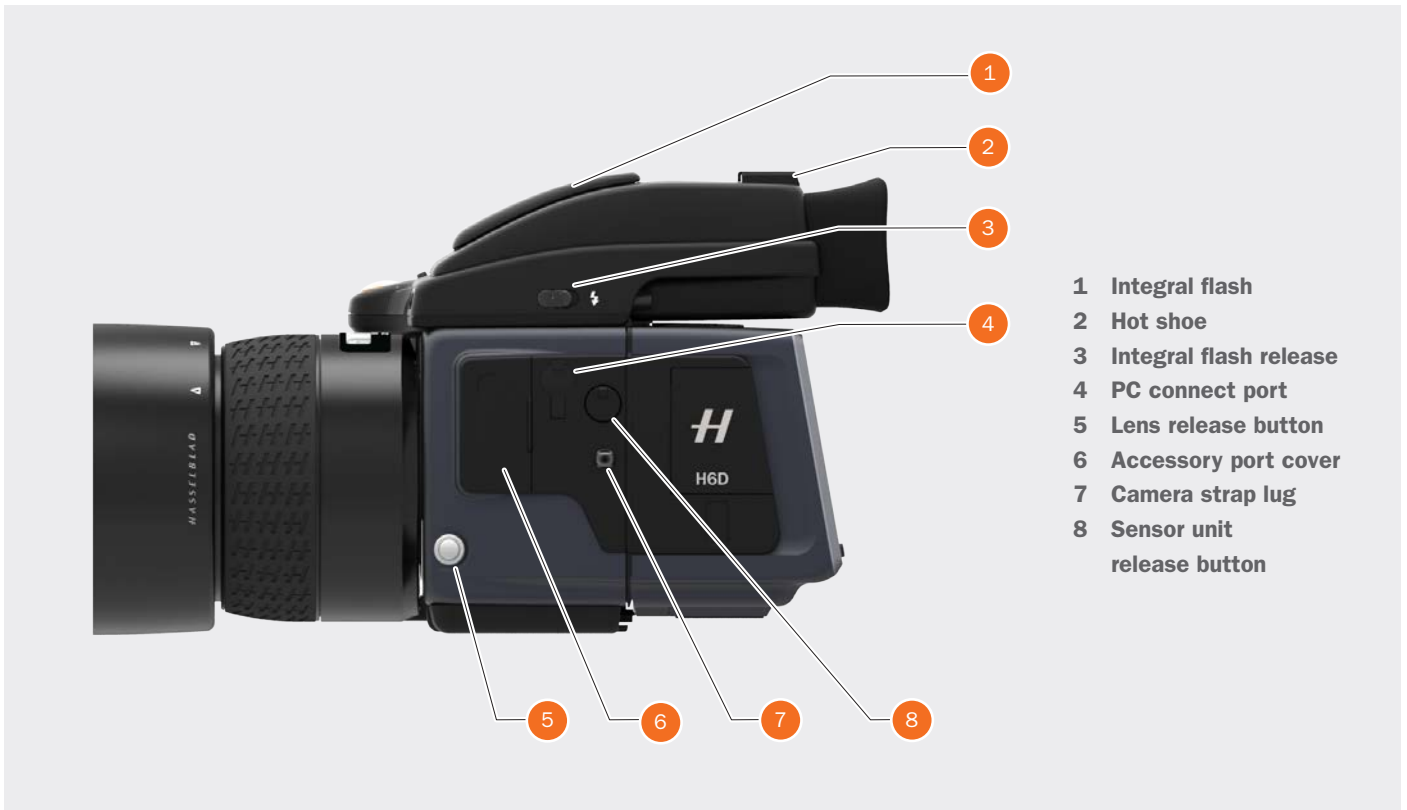

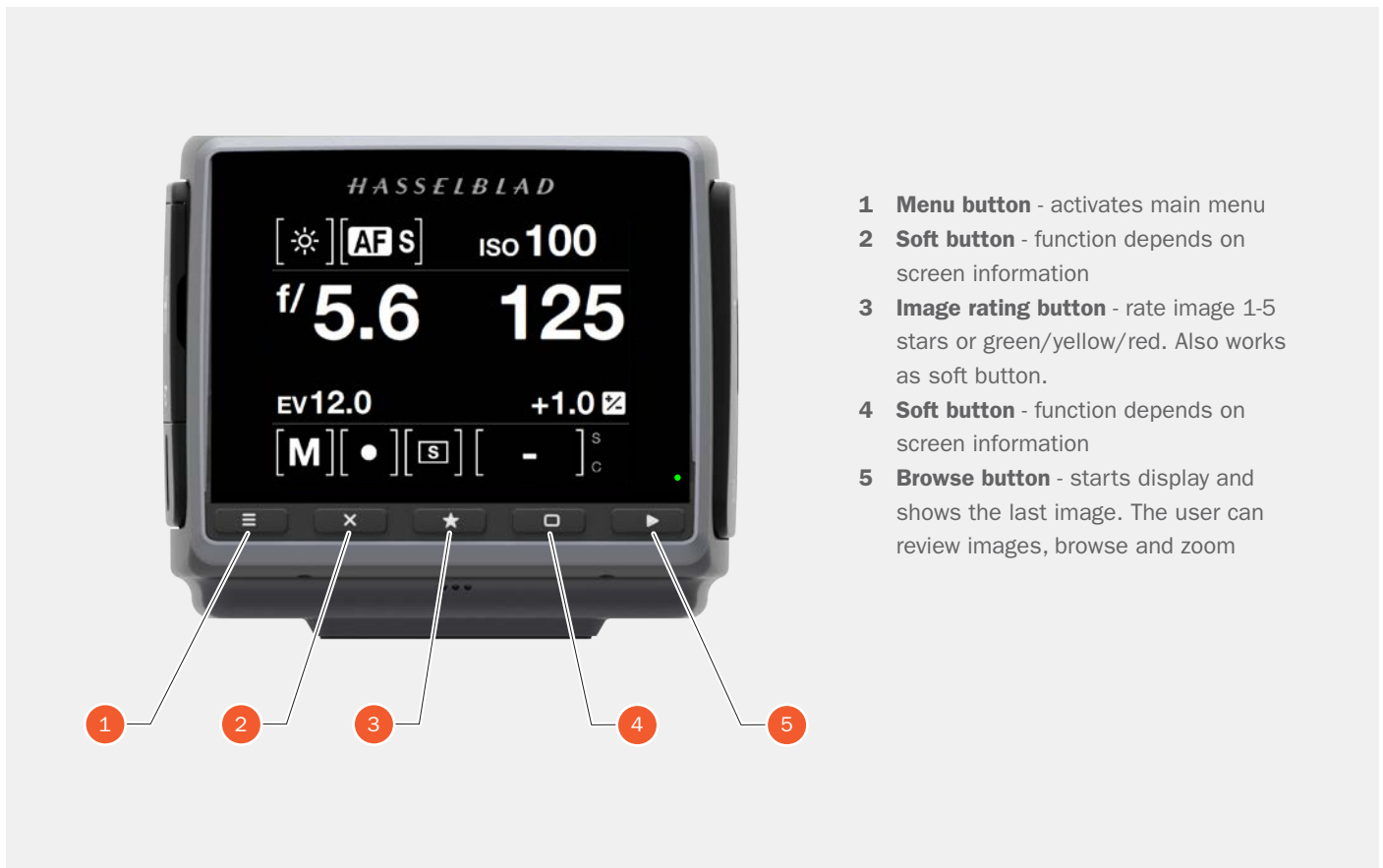
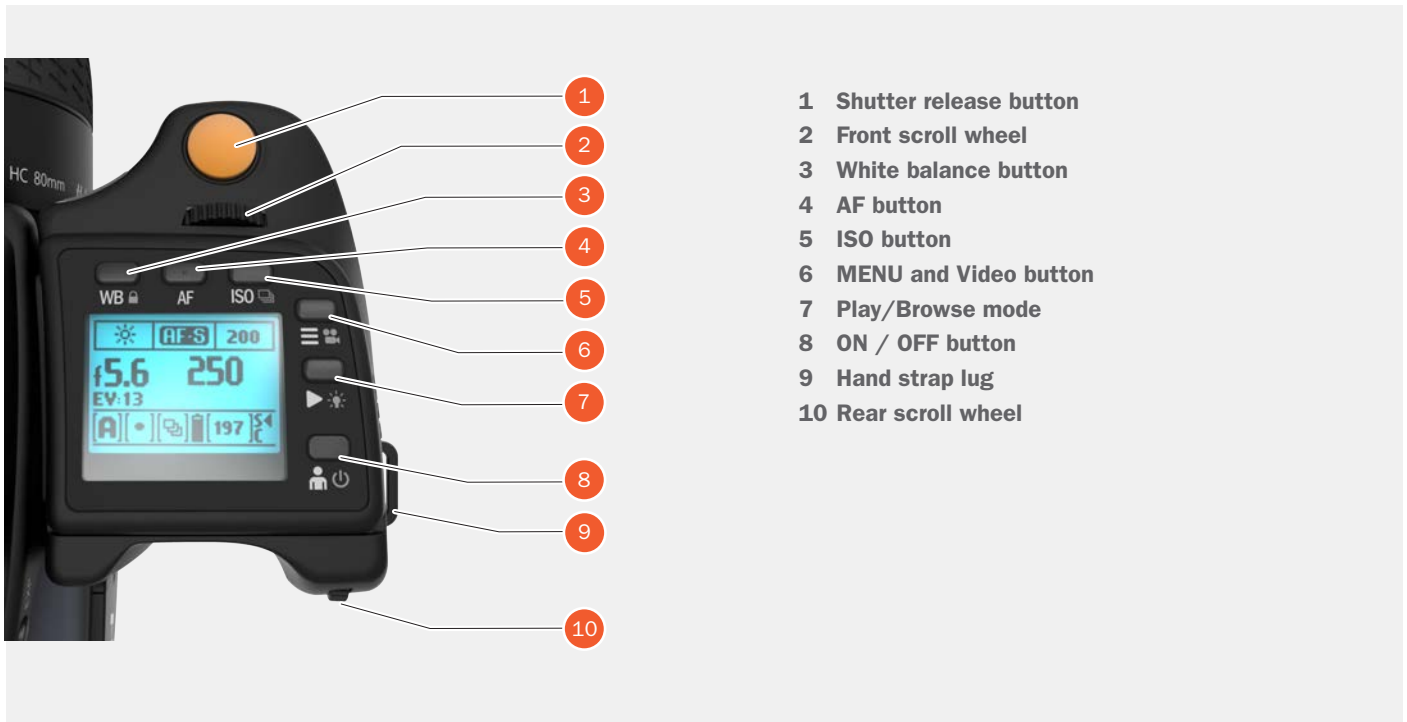

3.4 GRIP BUTTONS AND CONTROLS

Note that some of the buttons have multiple functions according to the settings made.

1 Shutter release button

This button has two positions. Press half-way (or softly) to activate the camera, auto focus function and exposure meter. Press all the way down (or more firmly) to release the shutter. The chosen exposure procedure and the self timer are also activated with this button.

2 Front scroll wheel

The front and rear scroll wheels are used to make changes in exposure settings, provide access to the grip menu for settings, navigate the sensor unit's menu as well as acting as browse controls.

3 WB button / (Control Lock)

This is a triple function button. Press the button for one second and the beeper will sound (if set) and a key symbol will appear on the grip display signifying that the controls (except the shutter release) have been locked and therefore cannot be altered unintentionally. Press the button for one second again to unlock.

4 AF button

Press this button to directly access the autofocus/manual focus selection screen from the main screen. See under Lenses for full details.

5 ISO

This is a triple function button. It provides direct access to the ISO settings (see Light Metering & Exposure Control for full details). A long press on the ISO button toggles Drive Mode between Single and Continuous.

6 MENU / Video button

Press this button to activate the Main Menu on the Sensor Unit Display. A long press activates Video Recording Mode. A long press again returns to Camera Mode.

7 Browse Mode / Illumination

One click enters Browse mode. Click again to exit Browse mode. The wheels now controls Aperture/Shutter. A long press illuminates the display. Remains active until the camera enters Display Off mode.

8 ON / OFF (Profiles) button

Press the button for 1 second to activate the camera. The H6D start-up logo will appear and then the main screen.



After a few seconds (customizable) the camera will enter Display Off mode. A long press of the button turns the camera off completely (even from Display Off mode) signified by an audible signal (if set). Click on the button to access the Profiles feature (see later section for details).

9 Rear scroll wheel

The scroll wheel is used to make changes in exposure settings, to provide access to the grip menu for settings, to navigate the sensor unit's menu as well as acting as browse control.

Note!

For the soft buttons 3 to 8 there is a difference between a short click and a long press. A long press is at least one second. Soft button 4 does not have any long press function.

3.5 CAMERA BODY BUTTONS AND CONTROLS

1 True Focus button

As default setting, this button activates True Focus (see separate section for description), but it also acts as a Zoom-in button when browsing or as Selector button when making a setting change on the sensor unit, according to mode. This button can be programmed to have other functions.

2 CFast and SD Card format button

This button displays the Format Dialogue on the Sensor Unit Display. It is recessed to prevent unintentional use.

3 AE-L button

As default setting, this button activates AE-L that locks a light reading made in both automatic and manual exposure modes. It also acts as a Zoom out button when browsing or as Exit button when making a setting change on the sensor unit, according to mode. This button can be programmed to have other functions. See Light Metering and Exposure Control/AE-L button for full details.

4 M.UP button

This button has a toggle function: press to raise the mirror and press again to lower it. A quick double press of the button (two within a half second) will access the Self timer function. This button can be programmed to have other functions.

5 Remote release cord port

Port to attach a remote release cord (electrical). The socket is protected by a captive rubber plug.

6 STOP DOWN button

Press to make a visual check of the depth-of-field on the viewfinder screen at the chosen aperture. The aperture will close according to the setting and remain closed as long as the pressure is maintained. You can alter the aperture at the same time to see the changes taking place. This button can be programmed to have other functions.

Note!

Some buttons can be re-assigned to other functions. There are three control buttons on the rear of the grip.



Note!

Customizable buttons True Focus, AE-L, M.UP and Stop Down, are very useful and can save you a great deal of time and effort. See separate sections for full details.

3.6 SENSOR UNIT

1 MENU / (EXIT) button

This button opens and closes the menu system. It is also used for other tasks (for example EXIT button) as you issue commands navigating the menu system.

2 Soft button

This button is “delete image” in browse mode. Can also be soft button depending on screen information.

3 Image rating button

Rate image 1-5 stars or green/yellow/red. Also works as soft button. (Only available in a later Firmware release).

4 Soft button

Function depends on screen information.

5 Browse button

Starts display and shows the last image. The user can review images, browse and zoom. Preview images and zoom in to view close-ups of previews for focus checking. Zoom out to view several at once and finally to view and select folders and media.

6 CMOS and IR filter

The sensor is positioned behind a permanently mounted IR filter. Always be very careful not to touch or scratch the surface of the filter when it is exposed. Replace the protective cover whenever the sensor unit is not mounted on a camera.

7 Data bus connectors

Connectors for digital communication with the camera body.

8 Retaining bar

Main support for the sensor unit.

9 Storage media cover

CFast or SD cards.

10 Connections cover

Cover for External Connections.

11 Audio Out

Connector for external 3.5 mm Stereo Audio Out Plug.

12 Flash sync input

Connector for 2.5 mm Flash Sync input plug.

13 Audio in

Connector for Audio In Microphone 3.5 mm stereo plug.

14 Flash sync output

Connector for 3.5 mm Flash Sync output plug.

15 External power in

Connector for External Power in plug.

16 HDMI

Connector for Mini HDMI plug.

17 USB 3 Tethering plug

Connector behind protective door for USB 3 plug.

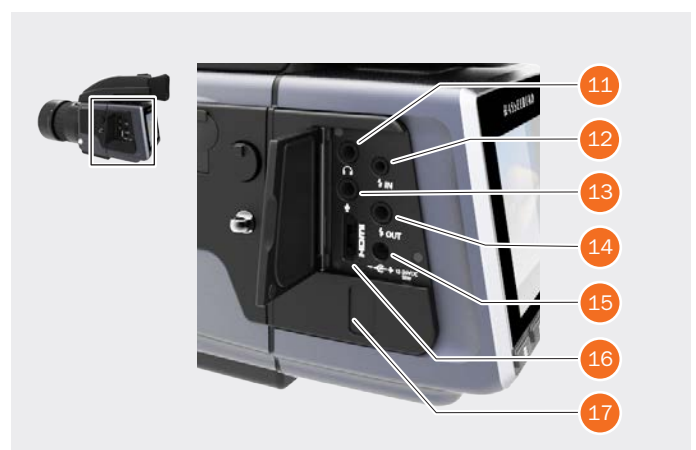
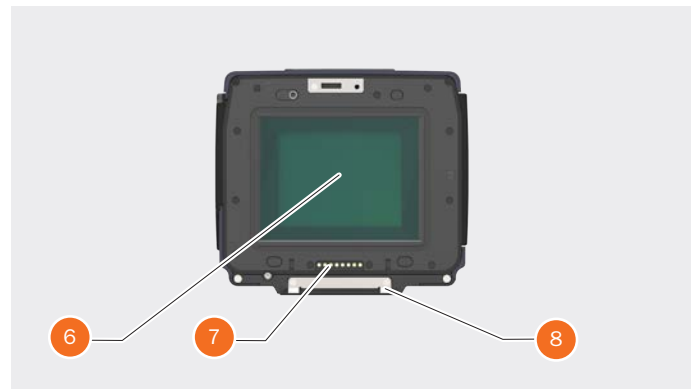
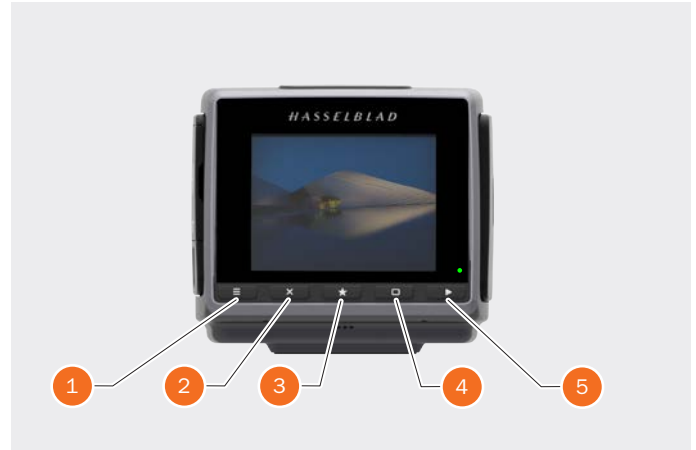

3.7 VIEWFINDER



1 Hot shoe

Connection for automatic flash unit (with SCA 3902 adapter) or for wireless flash trigger.

2 Rubber eye cup

Can be exchanged for another model.

3 Eyesight adjustment wheel

The personal eyesight adjustment facility has a dioptre range of -5 to +3.5, to suit most users.

4 Exposure and flash compensation button

Press this button to access the EV compensation screen. Flash settings are made with the front scroll

wheel. Exposure settings are made with the rear wheel. The EV correction values are shown on the grip. In the viewfinder display, a plus or minus symbol is shown, if the value differs from zero.

5 Exposure mode / Metering mode

The EXP (Exposure) button accesses the exposure and metering mode options screen. Settings are made with the front and rear scroll wheels and the appropriate symbols appear on the grip and viewfinder displays accordingly.



6 Integral flash unit

Manually opened with flash unit release button.

7 Integral flash unit release button

Slide the button towards the rear of the camera to raise the integrated flash. Activation is automatic.

8 Viewfinder release button

Press towards the front of the camera and lift the viewfinder upwards. Mount protection lid.

3.8 LENSES



You can also download technical data sheets from the Hasselblad website, www.hasselblad.com, or you can download a combined version. You can also download a lens booklet that contains a round up of the available lenses and some general information.

3.9 DISPLAY INFORMATION

Viewfinder information

- Metering method
- Aperture setting
- Shutter speed
- Exposure method
- Capture counter
- Exposure compensation
- Focus assist
- Warning triangle
- Flash warning
- Spirit level
- ISO
- WB

Grip LCD information

- Metering method
- Aperture setting
- Shutter speed
- Exposure method
- Capture counter
- ISO
- White Balance
- Flash indication
- Focus
- Drive
- EV
- Battery status
- Histogram (optional)
- Memory Card Status



PHOCUS / PHOCUS MOBILE INFORMATION

- Metering method
- Aperture setting
- Shutter speed
- Exposure method
- ISO
- White Balance
- Flash indication
- Focus
- Drive
- EV

Rear LCD information

- ISO / White Balance
- IAA rating
- Storage medium
- OPTIONAL
- Exposure comp.
- Histogram
- Date
- Time
- Lens focal length
- Spirit level



Optional accessible full screen display of grip information to show:

Metering method, Aperture setting, Shutter speed, Flash indication, Focus, Drive, EV, Battery status, Exposure method, Capture counter, ISO, White balance.

3.10 SENSOR UNIT DISPLAY AND CONTROLS

When shooting, the Sensor Unit can display the information most often required for a quick settings check. The unit's buttons, grip scroll wheels and camera buttons together with the touch display are used to navigate the main menu and change settings.

The touch display can show all saved captures on a CFast or SD card. You can Browse and Zoom the Captures for detailed inspection.

When shooting, you can control the amount of information visible together with the current preview by choosing various modes.



Buttons and scroll wheels

In Browse mode, the Scroll Wheels, True Focus and AE-L buttons are used for navigation.

Activate Browse mode by pressing on the right button below the Sensor Unit Display or on the Browse button on the Grip.



Control Screen with Grip information

The Control Screen is interactive. Swipe down to display the Control Screen. Select any of the settings to change the value. Aperture setting, shutter speed, focus setting, drive, EV, battery status, exposure method, capture counter, ISO and white balance can simultaneously be displayed and changed on the sensor unit on the Control Screen.



3.11 GRIP DISPLAY

TYPICAL GRIP DISPLAY

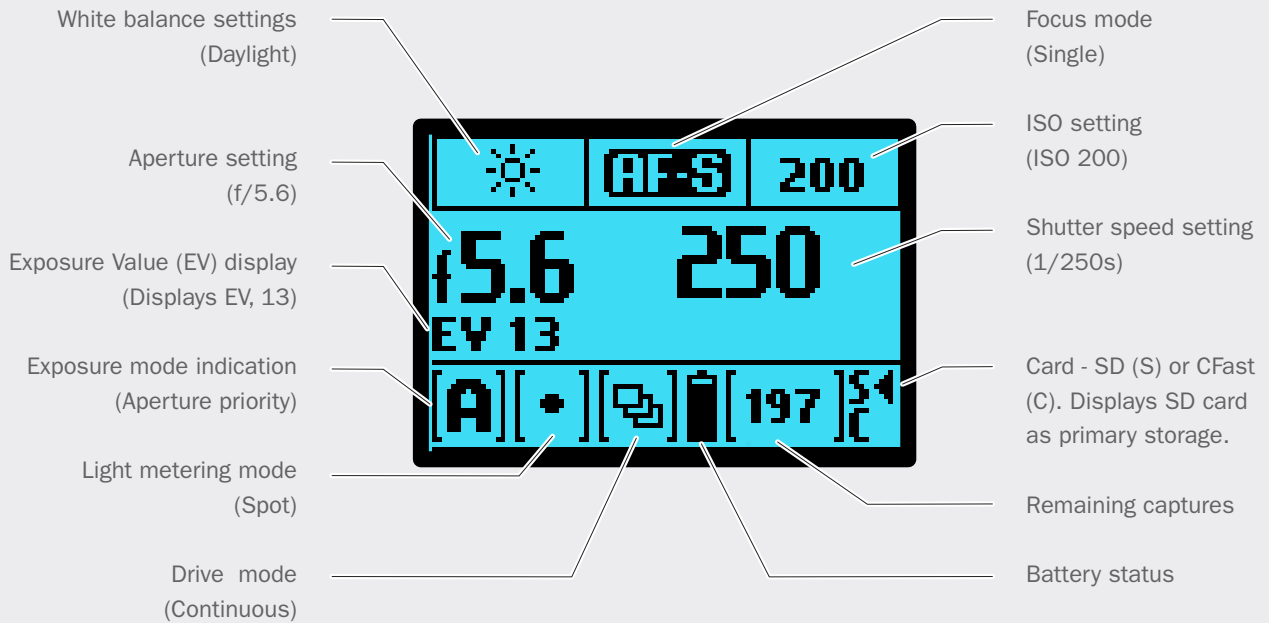

TYPICAL GRIP DISPLAY WHEN CHANGING SETTINGS



- 1 **White Balance, Autofocus and ISO settings**
The upper row on the screens display the White Balance (WB) the selected Autofocus (AF) and ISO settings selected.
- 2 **Settings symbols**
Symbolize the options available when settings are changed.
- 3 **Setting information**
The lower row on the screen displays information about the current state of the setting.

Note!

Scroll wheel description and direction
Arrowheads symbolize which scroll wheel should be used to change setting.

left and right arrow = front scroll wheel
up and down arrow = rear scroll wheel



3.12 VIEWFINDER DISPLAY

TYPICAL VIEWFINDER DISPLAY

Viewfinder Display visual user interface

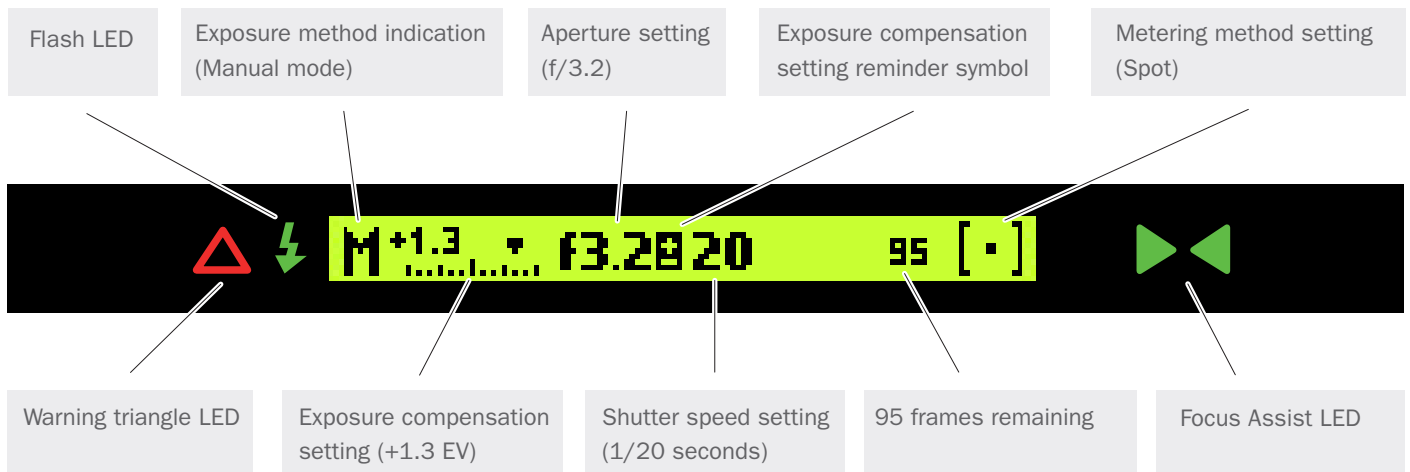

Note!

The LED's will only be visible when activated by the camera or a setting.

VIEWFINDER DISPLAY ACCORDING TO SETTING

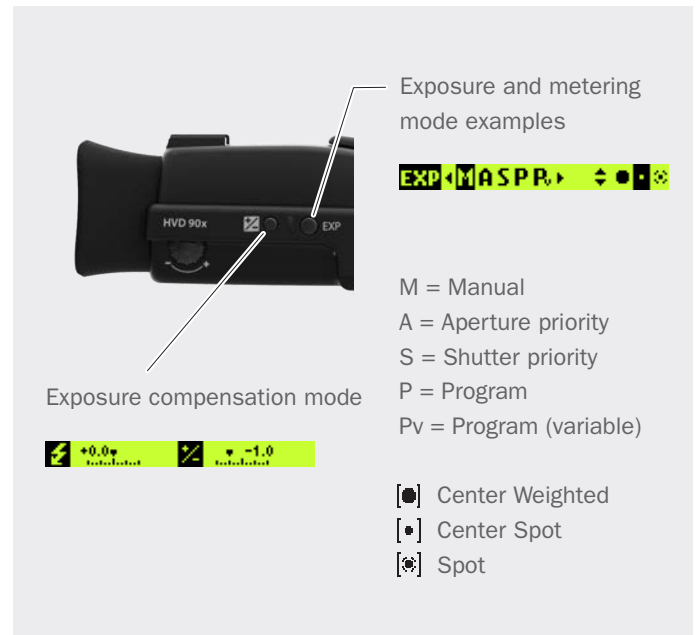
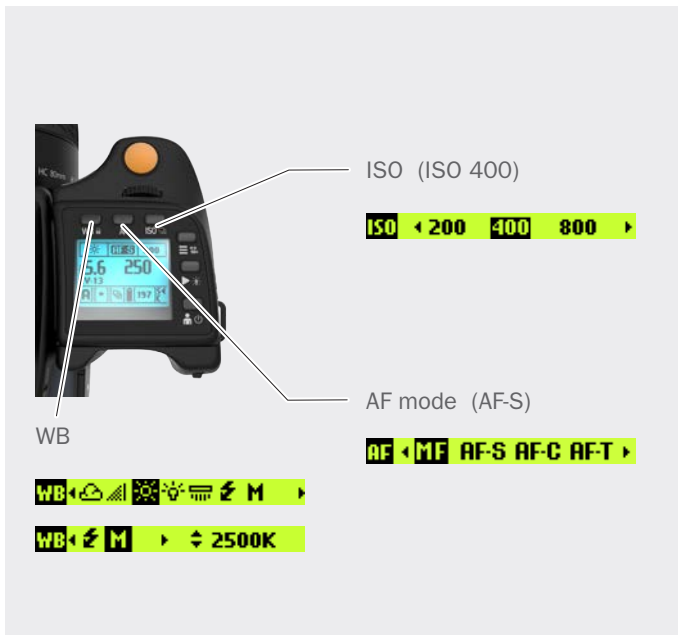

Exposure and metering mode examples

- M = Manual
- A = Aperture priority
- S = Shutter priority
- P = Program
- Pv = Program (variable)

- Center Weighted
- Center Spot
- Spot

Overview

3.13 RE-ASSIGNABLE GRIP BUTTONS FUNCTION OPTIONS

These four grip buttons are by default assigned according to name but can be reassigned (in Main Menu > Camera Settings > Controls or in the Camera Configuration tool in Phocus) to various other functions listed here.

True Focus

Temporarily activates True Focus function.

AF-Drive

Temporarily activates AF Drive.

AE-L

Temporarily locks a light reading in auto or manual modes. Also used in Zone metering.

M.UP / Mirror up

Locks mirror up for minimal vibration.

Stop down

Activates stop down function for depth of field checking.

Self timer

Sets self timer mode. Provides a timed remote shutter release function with the option of a change in sequence of the mirror movement (to reduce vibration).

Bracketing

Sets Bracketing mode. This function provides an automatic series of captures; one at the standard exposure setting, Manual or Auto, and the others with predetermined deviations in EV from the standard exposure.

B mode

Sets B mode shutter setting. Shutter stays open as long a pressure is maintained on shutter release button.

T mode

Sets T mode shutter setting. Shutter stays open after first press of shutter release button (toggle function to close again).

Flash Measure

Activates manual flash measure function.

Interval timer

Activates interval function start screen.



Cycle Light Meter mode

Selects next light metering mode.

Expose

Provides alternative to shutter release button.

3.14 SHORT CUTS

- 1 Menu button** – Setting option access. Press MENU button on the Sensor Unit.
- 2 Browse button** – Starts image browse mode.
- 3 Shutter release button** – Camera activation. Re-activates camera from Display Off mode. After making any changes, press EXIT (Menu button) or shutter release button to save the new setting.
- 4 Shutter release button** – A half press always exits all menus and returns to shooting mode.
- 5 Front scroll wheel** – Menu navigator / Browser. Functions as a horizontal navigator on sensor unit menu as well as a capture browser in Browse mode.
- 6 Menu button** – Toggles the Grip Menu Mode On and Off. When in Menu Mode the wheel is used to navigate the menus of the Sensor Unit. When not in Menu Mode the wheel controls the Aperture and Shutter speed. A long press on this button toggles the camera between video and camera mode.
- 7 Profiles button** – Camera activation. Enters Profiles menu. Profiles will be available in a firmware update. Re-activates camera from Display Off mode.
- 8 Rear scroll wheel** – Menu navigator. Functions as a vertical navigator on sensor unit menu while in menu mode. When not in Menu Mode the wheel controls the Aperture or Shutter speed.
- 9 True Focus button** – Camera activation. Re-activates camera from Display Off mode.
- 10 True Focus button** – Zoom-in button. Automatically acts as Zoom-in button when in Browse mode.
- 11 True Focus button** – Selection button. Automatically acts as value selector on sensor unit menu when in Menu mode.
- 12 CFast and SD Card format button** – Formats the current inserted CFast or SD card (requires confirmation).
- 13 AE-L button** – Re-activates camera from Display Off mode.
- 14 AE-L button** – Zoom-out button. Automatically acts as zoom-in button when in Browse mode.



- 15 AE-L button** – Selection button. Automatically acts as value selector on sensor unit menu when in Menu mode.
- 16 Mirror Up button** – Camera activation. Re-activates camera from Display Off mode.
- 17 Stop Down button** – Re-activates camera from Display Off mode.

3.15 PHOCUS OVERVIEW



Phocus

Phocus is the Capture Processing and File Management application aimed primarily at Hasselblad 3F file handling. Phocus is available for both Mac and Windows.

Professional Image Quality

Phocus combines Hasselblad Natural Colour Solution (HNCS) with Digital Auto Correction (DAC) to provide high digital image quality in the images you create. With Phocus, the moiré effect that can occur on even extremely high resolution images is effectively removed automatically and directly on the raw data, leaving the image quality intact and saves time in post production work. Tethered shooting is efficient with Phocus Remote camera controls providing a number of remote functions. For example remote focusing, live view, aperture and exposure time controls.

Phocus Mobile

Phocus Mobile is available for iPhone®, iPad® and iPod Touch®. It enables you to connect wireless to a computer running

Phocus and to remotely browse your high-resolution RAW, JPEG and TIFF images. This provides a solution for working with clients in the studio, enabling each person to view images on an individual iOS device, rather than all gathering around a single computer. Phocus Mobile also allows users to remotely operate and trigger a tethered camera, giving control of many parameters, all neatly presented in a virtual camera display. This feature is very convenient for remote control of the camera when it's located in a difficult to access position.

Phocus Mobile is available for free download in the Apple App Store. www.apple.com.

3.16 CAMERA CONFIGURATION IN PHOCUS

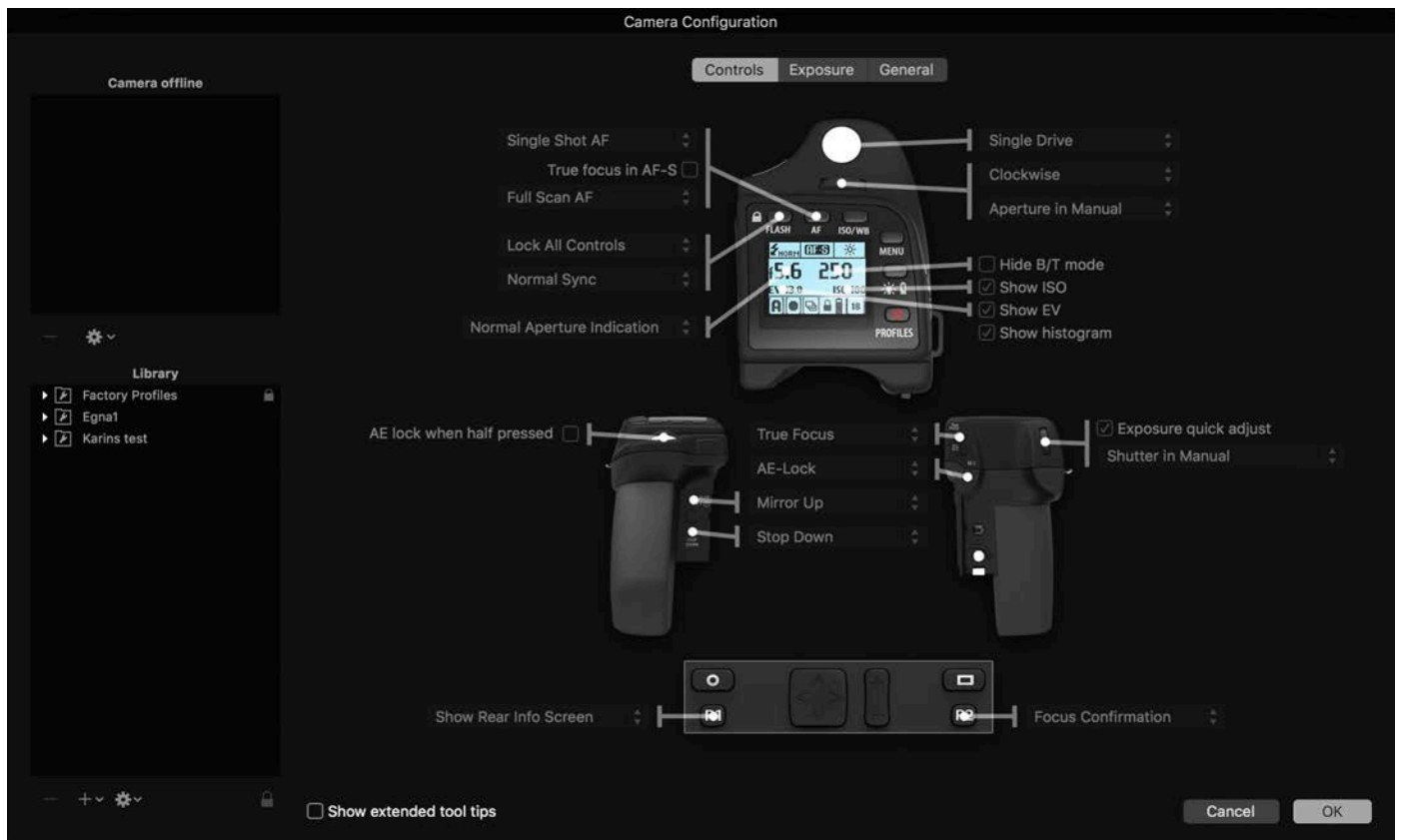

The Camera Configuration tool in Phocus offers a very thorough and secure way of creating comprehensive profiles for the H6D. There are three windows – Controls, Exposure and General – that present virtually all parameters to enable total control at the press of a button. This means that separate and specific custom profiles created in advance can cover a number of shooting scenarios.

In addition these profiles can be easily imported and exported. For instance, you can create a special profile to suit a specific type of shoot and keep it on a memory stick or laptop. So, when renting an H6D for example, you only have to upload the saved profile to ensure that all parameters have been reset without you having to go through each detail – simple and secure.

The interface has three tabs at the top, Controls, Exposure and General, that access the windows. Descriptive information appears as you mouse over the various menus and extra tool tips are additionally available as an option. To take an example, the Controls window is illustrated here. On the left are two lists: Camera and Library. The Camera list includes the various available configuration profiles already stored in the camera – the profile currently in use as well as the default settings and those you have created or imported from other sources. Library contains the factory pre-sets stored on disk.

Creating a profile

- 1 Open Camera Configuration located under the Windows menu.
- 2 Connect the camera and in the Camera list click on a profile you want to change or a spare profile and name it.
- 3 Cycle through the three windows, Controls, Exposure and General, making the appropriate selections that you require. When complete, select the new profile and drag and drop or right click it to store in the Library.
- 4 Right click the Library version of the profile to access the Transfer Profile Set to Camera option then click on OK to complete the action. This causes the new profile to appear on the grip display for selection when you click on the Profiles button.

Right click a profile in Library to access the Rename, Reset to Standard, Delete and Export options if required. Import, Export, Transfer, Add Profile etc. tools are also available.

3.17 BATTERY AND BATTERY GRIP

Rechargeable battery grip

The environmentally approved Battery grip Li-ion (3043357) is the standard power source for the H6D camera. The H6D requires a power supply for all actions as there is no mechanical reserve facility. It is therefore advisable to keep a reserve rechargeable battery grip at hand. As is the case with most batteries, problems might be encountered when used in very low temperatures. In this situation it is advisable to keep the reserve battery in an inside pocket, for example, to maintain it near body temperature.

Remove a battery

Remove the battery from the camera by pressing the battery holder button (1) and simultaneously swinging the battery holder retaining lever (2) down until it stops.

Pull the battery downwards (3).

Mount a battery

To fit, hold the battery flat against the camera body and aligning the two upper lugs with the slot, slide it back into position as far as it will go. Swing back the battery holder retaining lever (2) until it clicks back into place.

Store a battery

If you intend to store the battery separate from the camera, ensure the safety cover is mounted over the electric connections on the battery to prevent short-circuiting. It snaps into place and is removed by pulling outwards and upwards on the locking clip.

Connect battery to charger

Mount the charger plug in the plug connector on the inside of the battery (4).

See next page for more in depth information.

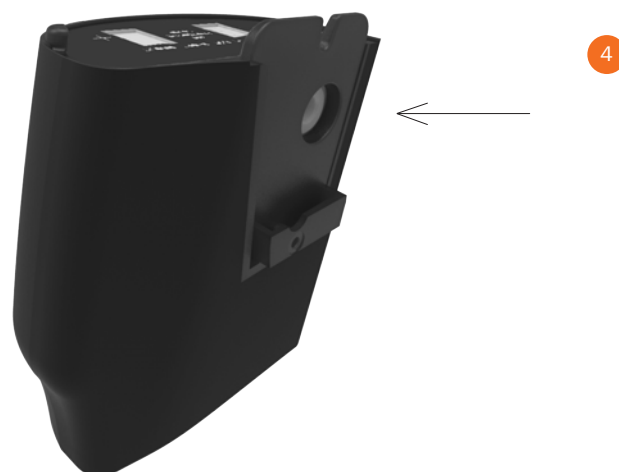

Overview

3.18 BATTERY CHARGER

The battery charger is supplied with a number of plug attachments to suit various types of domestic electrical sockets available worldwide. Other types of socket will require a domestic socket converter.

Attach the chosen plug by sliding it into position as in the diagram. Removal is by the reverse procedure. Please note that the Battery charger BCH-2 (3053572) is designed for use with Battery grip Li-ion 3200 (3043357) but can also be used together with the Battery grip rechargeable 7.2V Li-Ion 2900 (3043356) intended for H5D use.



CHARGE THE BATTERY

With the battery removed from the camera, insert the jack plug from the battery charger into the socket on the battery grip (1). Insert the battery charger into a standard (100–240V~/50–60 Hz) domestic socket.

During the charging procedure, the lamp on the charger signifies the following:

- | | |
|----------------------|--------------------------------|
| Steady Green light: | Standby (no battery connected) |
| Steady Yellow light: | Charging |
| Steady Green light: | Ready! |

NOTE!

It can take about 6 hours to charge the battery completely up to 100% the first time.

See next page for more details and precautions.



RECHARGEABLE BATTERY GRIP SPECIFICATION

LHION/ BATTERY CHARGER 3053572 BCH-2

– PRECAUTIONS and GENERAL

The battery should be charged for approximately 6 hours before first time use.

The battery must be charged at room temperature.

Maximum battery capacity is reached only after the battery has been charged and discharged several times.

Avoid frequent full discharges (a full discharge is signalled by the appearance of the Replace battery warning on the grip display). As the battery is a Li-ion type, it has no 'memory effect' of practical importance and therefore frequent recharges will cause no problems such as loss of capacity or poor performance. It is therefore better policy to recharge the battery at very regular intervals, regardless of use.

Remove the battery if you intend to store the camera for some while as it will eventually become completely drained, even though the camera is turned off.

The battery has an integrated 'fuel gauge' capability that supports the Replace battery and Battery status functions on the grip display. As with most Li-ion batteries, this capability should be occasionally calibrated, depending on how much the battery is used. To do this, leave the camera on (or use it), until the Replace battery warning appears. Then, recharge the battery for 6 hours. This will improve the accuracy of the measurements.

When removing a battery from the charger and immediately replacing it with another, allow a few seconds to elapse so that the charger can automatically reset for the next charging procedure.

It is perfectly normal for the battery to become warm when being charged.

A slight temporary loss of battery performance might be noticed at very high or low temperatures. Take the appropriate measures if this is the case.

If you do not intend to use the battery for a while, it is best to store it at room temperature with an approximate 30 to 40% charge. You can check the percentage level on the status screen.

The battery should have a usable service life of around 400 recharge/discharge cycles.

Connect the battery grip to the camera correctly.

Keep the protective cover in place when not in use. (Short circuiting across keys in a pocket, for example, could cause a fire risk).

Do not immerse the battery grip in liquids.

Do not incinerate the battery grip.

Please recycle or discard in an environmentally approved manner.

Use indoors only (protect against moisture).

Do not short circuit the jack plug.

Do not alter the charger in any way other than changing the plug attachment.

Note!

You can save battery consumption by changing the Display Off / Sleep / Power Off settings as well as the brightness settings of the display.

BATTERY LIFE AND BATTERY WARNING

Battery life is dependent on a number of variable factors and therefore cannot be exactly predicted. If the camera is left in the active state instead of Display Off or Sleep modes for long periods, for example, then the battery will become exhausted much faster. A low camera battery state is indicated by a symbol on the grip display, in the viewfinder as well as on the sensor unit display. In addition, an audible signal sounds. When the battery is almost completely exhausted, a warning message “Replace battery” will appear on the grip display.

3.19 TEMPERATURE WARNING

Many rapidly taken captures make heavy demands on the processor in the sensor unit which in turn produces heat. This, particularly in combination with high ambient temperature, can result in noise in the image files. To prevent this, the sensor unit displays a warning icon when the temperature rises. At ca. 60° C a warning dialogue appears notifying that the sensor unit is temporarily shutting down to allow the unit to cool.



3.20 POWER MODES

MAIN MENU > GENERAL SETTINGS > POWER & TIMEOUT

The H6D Camera can be set to automatically turn off the Sensor Unit Display after a set amount of seconds to save battery for example.

It can also be set to Power Off after 5, 10 or 30 minutes.

- 1 Press the General Settings icon on the Sensor unit display.
- 2 The General Settings Menu will appear.
- 3 Press the Power and Timeouts icon.

Swipe right or press Menu / EXIT button to get back to Main Menu.



Power and Timeouts Menu

Display Off

Select Display Off Settings.

- 3 seconds.
- 5 seconds.
- 10 seconds.
- 20 seconds.
- 30 seconds.
- 60 seconds.
- Never.

Power Off

Select Display Power Off Settings.

- 5 minutes.
- 10 minutes.
- 30 minutes.
- Never.

3.21 AUTOMATIC SETTINGS

DISPLAY OFF

MAIN MENU > GENERAL SETTINGS > POWER AND TIMEOUTS > DISPLAY OFF

In this mode the camera turns off the grip and sensor unit displays but remains ready to be immediately reactivated to the ON mode. The time intervals are: 3, 5, 10, 20, 30, 60 seconds and Never.

POWER OFF

MAIN MENU > GENERAL SETTINGS > POWER AND TIMEOUTS > DISPLAY OFF

In this mode the camera is completely without power and has to be started by pressing the ON button again - simple reactivation is not sufficient. The time intervals are 5, 10, 30 minutes and Never.



3.22 REMOVE AND ATTACH THE VIEWFINDER

To remove, hold the viewfinder in the right hand and while pressing the viewfinder release button (1), lift the rear of the viewfinder up and away from the camera body (2).

To attach, hold the viewfinder at a slight angle and rest it on the top of the camera. Slide the viewfinder forward until the front locating pin is in position in the recess in the front edge of the viewfinder screen aperture on camera body.

Press the rear part of the viewfinder firmly downwards until it clicks into place.

Ensure that both sides of the viewfinder are seated correctly and that it has been firmly attached and locked into position.

Failure to do so could cause an intermittent malfunction if the data bus interface connections between the viewfinder and camera body are not positively secured.

Note!

Do not lift or hold the camera by the viewfinder alone.

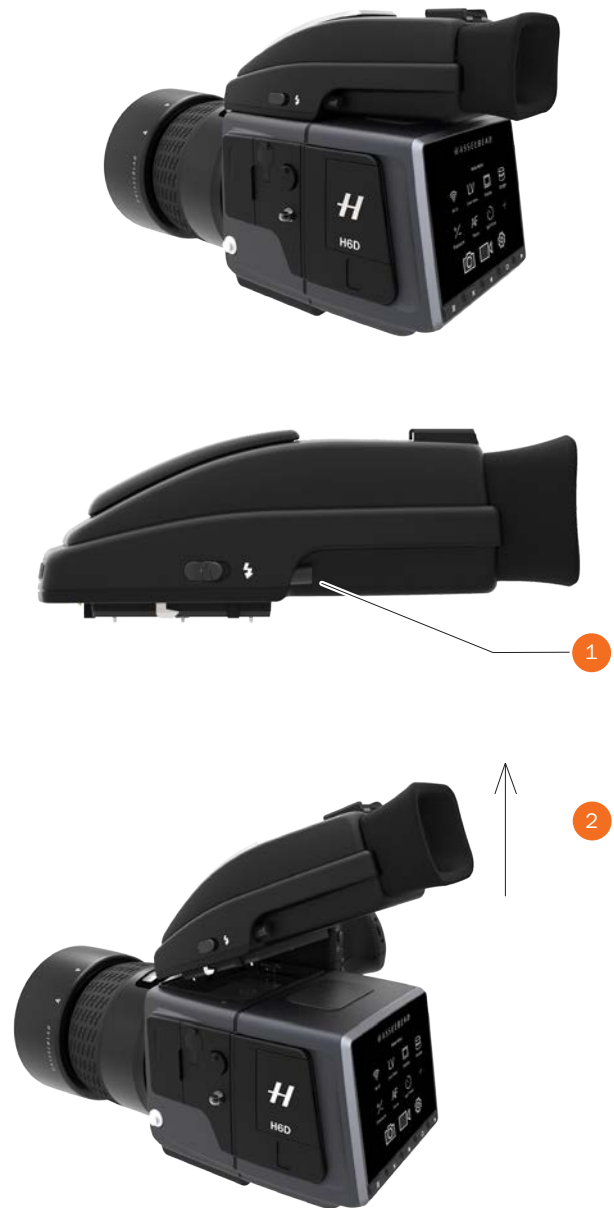

3.23 EYEPIECE ADJUSTMENT

No corrective lenses are needed to adjust the eyepiece to suit most requirements. The dioptre range is from -5 to +3.5D. Eyeglass wearers can rapidly and accurately change the settings according to whether they wish to wear eyeglasses for viewing or not. Personal eyepiece adjustments can be carried out by pointing the camera at the sky or similar smoothly toned area. While holding the camera in your left hand, you can with your right thumb turn the adjustment wheel until the markings on the viewfinder screen reach the optimum sharpness for your eyesight. If you normally wear eyeglasses for distance viewing and intend to wear them for camera use then do not remove them for the above procedure. If, on the other hand, you prefer to remove your eyeglasses for camera work, then repeat the above procedure without wearing your eyeglasses.



3.24 RUBBER EYE CUP

Two rubber eye cups are available for the H6D. The one supplied is suitable for users who do not intend to use eyeglasses when photographing. The second shorter eye cup is for those who either prefer to position their eye further from the viewfinder and those who wish to wear eyeglasses. The eye cups can be rapidly changed by a Hasselblad Authorized Service Center.



3.25 ACCESSORY CONNECTION

There are two accessory retaining screw threads (M5) as well as a data bus connector on the left hand side of the camera body, protected beneath a cover (1).

The cover can be removed by first lifting the left hand edge (1) a little and then sliding the cover to the left (2), as in the illustration.

Lift the front edge of the cover first (1).



3.26 PC FLASH CONNECTOR

A PC connector for non TTL flash synchronisation (3) is located on the left side of the body. It is protected by a captive rubber plug.



3.27 PROTECTIVE BASEPLATE

REMOVE THE PROTECTIVE BASEPLATE

- 1 To remove the protective base plate, lift the securing catch while pushing the plate towards the lens (A).



ATTACH THE PROTECTIVE BASEPLATE

- 1 To attach it again, slip it over the camera foot until it stops and the securing catch snaps into place (B).



3.28 MEMORY CARDS

There are two types of memory cards that can be used with the H6D camera.

- 1 CFast card.
- 2 SD card.

When using a CFast card or SD card, the H6D is completely self contained. No additional wires or connectors need to be attached.

The recommended type is UDMA/type 4 /60MBs (400x) or better. Please see the Appendix in this manual for a list of recommended cards.

The H6D is shipped with an 16 GB SDXC SD card, which is capable of holding approximately 75 – 150 captures (according to model).

Note!

All cards should be formatted in the camera before first use!

Memory Card Status Display

CFast card

- C = Inserted, non active.
- C< = Inserted, active.
- C[0] = Full.
- C! = Card Error.
- No Symbol = No Card inserted.

SD card

- S = Inserted, non active.
- S< = Inserted, active.
- S[0] = Full.
- S! = Card Error.
- Lock Symbol = Card Write Protected.
- No Symbol = No Card inserted.

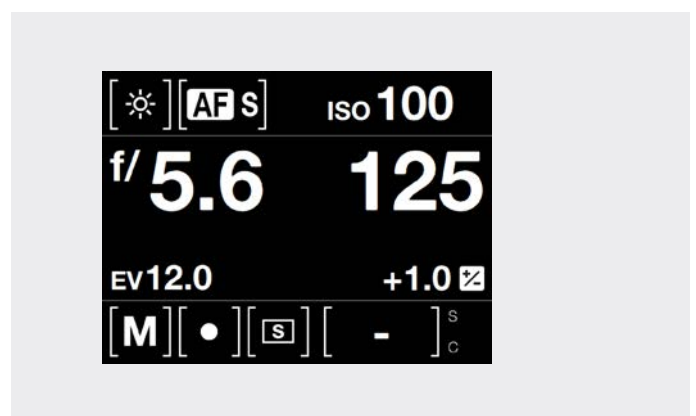
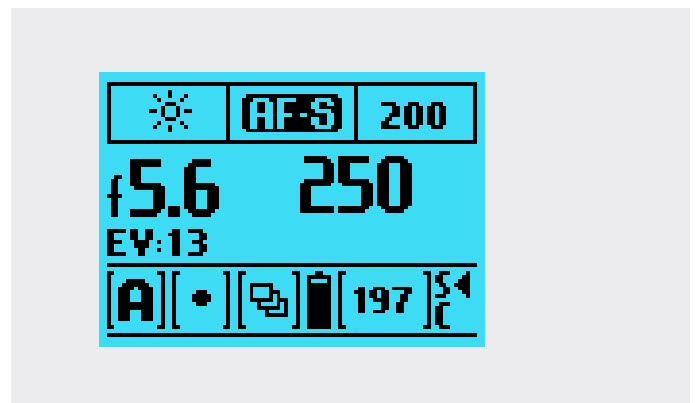

TO INSERT A MEMORY CARD

Insert CFast card

Open the CFast card cover (1) on the sensor unit by inserting a thumb in the recess and then sliding the slot cover backwards.

Behind the cover, you will see a cover for the CFast card (2) and a cover for the smaller SD card (3).

Hold the CFast card so that the connector holes face into the slot and you can read the brand label when you are behind the camera.

Gently press the CFast card into the slot. If you encounter resistance, it might be because you are holding the card backwards or upside down.

If the card can be easily inserted nearly all the way into the back, then you are inserting it correctly. Press the card another couple of millimetres firmly into place.

Close the slot cover and slide it to the right to lock it.

Insert SD card

When the card slot cover door is opened, mount the SD card in the SD card slot (3).

Close the slot cover and slide it forward to lock it.



TO REMOVE A MEMORY CARD

Remove CFast card

Open the memory card slot cover on the sensor unit (1).

Press the CFast card (2) a little way in and then release it.

As you do this, the card will be pushed out a few millimeters.

Grab the card and pull it away from the sensor unit.

Close the slot cover door.



Remove SD card

Open the memory card slot cover on the sensor unit (1).

Press the SD card a little way in and then release it. The SD card will then move out from the SD card slot (3).

Grab the card and pull it away from the sensor unit.

Close the slot cover door.



Note!

Do not remove a CFast or SD card from the sensor unit if the “ready” light is blinking! The “ready” light is displayed in the lower right corner on the Sensor Unit Display. All files on the card may become corrupted (and consequently lost) if you do so and new formatting may also be necessary.

Overview

FORMATTING MEMORY CARDS

MAIN MENU > GENERAL SETTINGS > STORAGE

The camera is only able to read and write to storage media that have been formatted correctly. New cards sometimes have no formatting, or you might want to convert a card that is currently using a format that the camera cannot read. In either case, you must reformat both CFast cards and SD cards in the sensor unit for H6D use.

There are two ways to format cards. The quickest way is to use the Format card button on the grip but if you prefer, you can also use the menu on the sensor unit.



FORMAT BUTTON

Press the Format button (A) on the camera grip. It is purposely recessed to avoid unintentional use, so use a ballpoint pen or similar. It is also possible to click the button with a hard press with the tip of your thumb. A prompt is displayed on the sensor unit for confirmation.



FORMAT MEMORY CARDS VIA SENSOR UNIT

MAIN MENU > GENERAL SETTINGS > STORAGE

- 1 Press MENU.
- 2 Navigate to General Settings.
- 3 Choose Storage.
- 4 Navigate to Format Card.
- 5 Navigate to Format CFast or Format SD.
- 6 Confirm by pressing OK (Display button).

Note!

Only UDMA/type 4/60MBs (or 400x) cards or better are recommended for H6D use. See full list in 'Appendix' in this manual.

Note!

All CFast and SD memory cards should be formatted in the sensor unit before using them the first time.

Note!

You can add a Favourite function on the Main Menu if you often use formatting.

Storage Menu

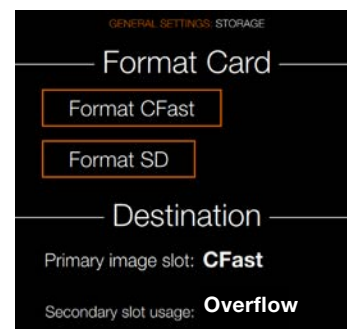

3.29 CARRYING STRAP



Carrying strap

First withdraw the safety collar. The hook is then freed and can be attached to the strap lug. Slide back the safety collar to ensure the hook remains in the locked position between the small protruding lugs. The collar is purposely a tight fit to avoid unintentionally slipping back and therefore might need some effort to slide.



3.30 REMOVE THE CARRYING STRAP

- 1 Withdraw the safety collar.
- 2 Remove the opened hook from the strap lug.



3.31 CHANGE LENS



ATTACH A LENS

- 1 Push the lens removal button (A) and remove protection cover lid (B) from the camera body.
- 2 Rotate the lens so that the red mark on the lens (C) lines up with the red mark (D) on the camera body.
- 3 Mount the lens into the camera body (E) and then turn the lens clockwise to lock its position.
- 4 Make sure the lens is locked to the camera body before using or moving the camera.



REMOVE A LENS

- 1 Hold the lens with one hand and hold the camera body (E) still.
- 2 Push the lens removal button (A).
- 3 Rotate the lens counter clockwise.
- 4 Push the lens away from the camera body.
- 5 Attach the protection cover lid (B) on the camera body directly.
- 6 Attach a lens protection lid on the detached lens to prevent damage.
- 7 Store the lens with both lens protection lids on and the lens hood (F) inverted over the lens instead of in front of the lens.



4.1 CHECK THE DELIVERY



- 1 Unpack all items.
- 2 Make sure that all the items listed on the attached package information are supplied.
- 3 Inspect all the items for damage.
- 4 If any items are missing or damaged, write down the product number of that item. If not, proceed to step 6.
- 5 Contact your Hasselblad dealer or distributor and tell them the product number of the item missing or damaged.
- 6 Keep the purchase details and the warranty in a safe place.

In the package

USB stick with instruction manual and Phocus software.

Viewfinder
Grip with battery
Sensor unit
Sensor unit protection lid

Camera body
Camera body protection lid

Lens (if included in purchase)
Lens hood
Lens protection lid x2

Battery
Battery electric socket protection lid
Battery charger plus connectors and cable



1 SD card included

USB 3 cable

Carrying strap

To Prepare

4.2 REASSIGN GRIP BUTTONS

These four grip buttons by default are assigned according to name but can be reassigned (in Main Menu > General Settings or in the Camera Configuration tool in Phocus) to various other functions listed here.

True Focus

Temporarily activates True Focus function.

AF-Drive

Temporarily activates AF Drive.

AE-L

Temporarily locks a light reading in auto or manual modes. Also used in Zone metering.

Self timer

Sets self timer mode. Provides a timed remote shutter release function with the option of a change in sequence of the mirror movement (to reduce vibration).

Bracketing

Sets Bracketing mode. This function provides an automatic series of captures; one at the standard exposure setting, Manual or Auto, and the others with predetermined deviations in EV from the standard exposure.

M.UP / Mirror up

Locks mirror up for minimal vibration.

Stop down

Activates stop down function for depth of field check.

B mode

Sets B mode shutter setting. Shutter stays open as long a pressure is maintained on shutter release button.

T mode

Sets T mode shutter setting. Shutter stays open after first press of shutter release button. Press the shutter release button again to close the shutter.

Flash Measure

Activates manual flash measure function visible in grip display.

Interval

Activates interval function start screen.

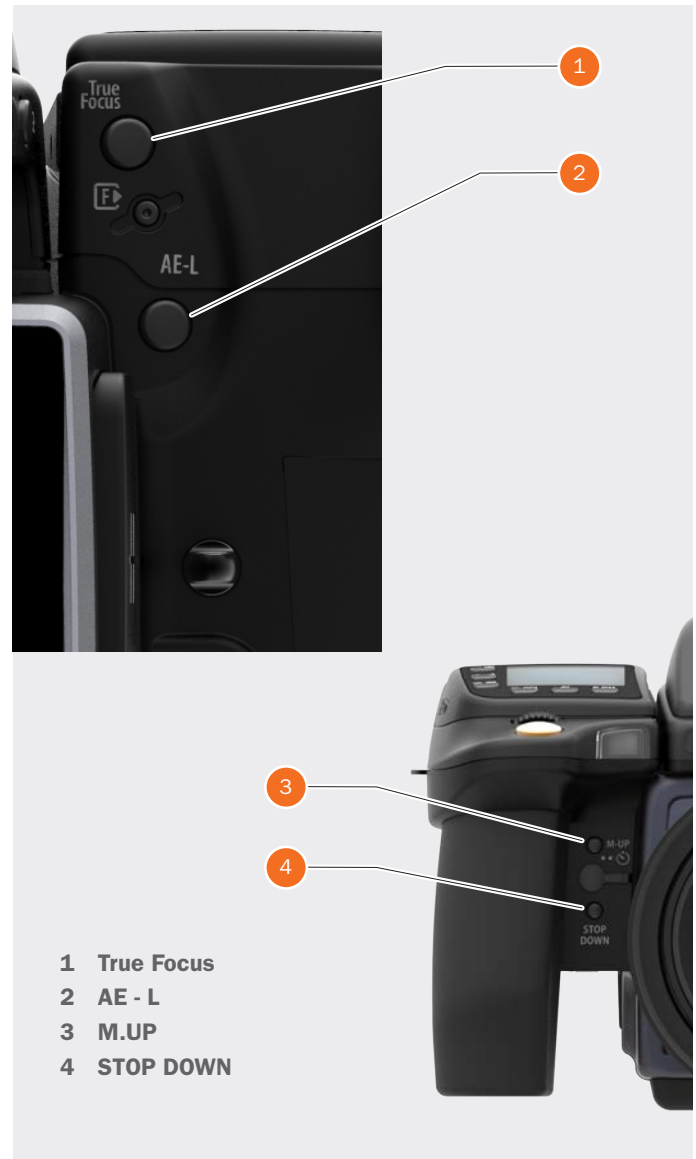

Cycle Light Meter mode

Selects next light metering mode.

Expose

Provides alternative to shutter release button.

4.3 CONNECT TO A COMPUTER

- 1 Connect a USB 3 cable to the USB port on the computer.
- 2 Open the hinged cover on the camera.
- 3 Connect the USB 3 cable to the USB port on the camera.

Note!

When connected to a computer, the following applies:

- The destination medium and location are controlled from Phocus.
- All exposure settings, including ISO, aperture and exposure time, are controlled from Phocus if you choose to expose from Phocus. In addition extra tools such as Live Video, remote focus control etc. are available. See Phocus user manual for full description.

Note!

Please note that the buttons on the unit have no function in this mode.

When initiating a shot from Phocus, the computer sends a signal to the sensor unit, which triggers the shutter (and strobe/flash, if any). The back then sends the capture over the USB connection to the computer, where it is displayed on the computer screen and saved as a 16-bit 3F file in the currently selected folder on the computer hard disk.

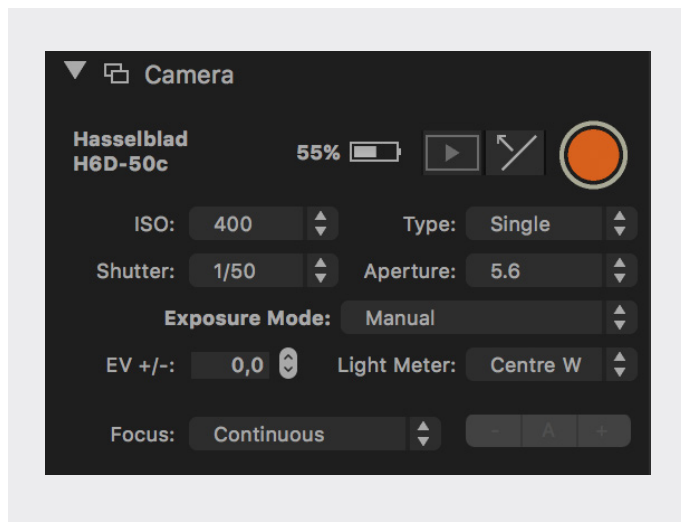

To Prepare

4.4 CAMERA INTERVAL SETTINGS

MAIN MENU > CAMERA SETTINGS > INTERVAL

Press the Camera icon on the Sensor unit display. The Camera Settings Menu will appear.

Select the Interval Settings Menu.

Swipe right or press Menu / EXIT button to get back to Main Menu.

Camera Menu

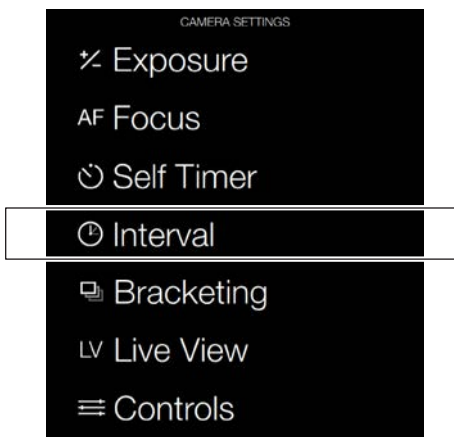

Interval Settings Menu

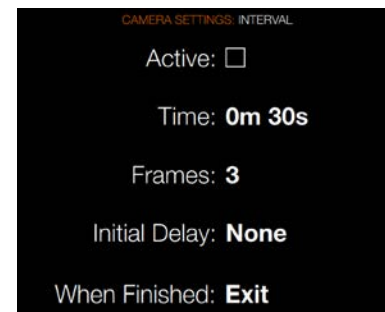

Interval Settings Menu

Active

On / Off.

Time

Select time between exposures in minutes and seconds.

Frames

Select number of Frames.

Initial Delay

Select initial Delay.

When Finished

Settings for Action When Finished.

4.5 SET DATE AND TIME

MAIN MENU > GENERAL SETTINGS > DATE AND TIME

Main Menu

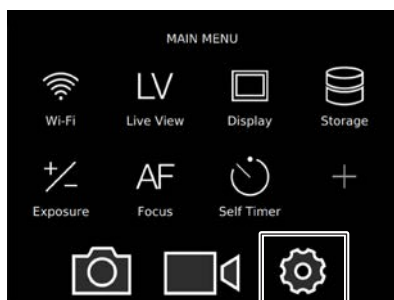

General Settings icon

General Settings Menu

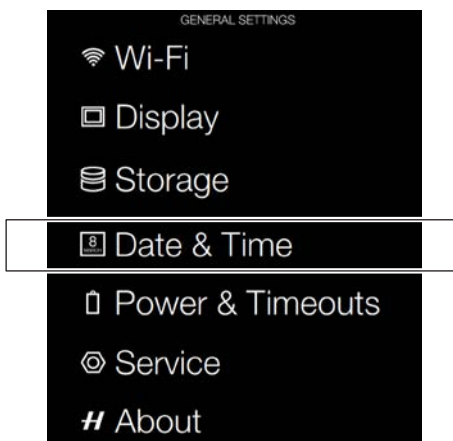

Date and Time Menu

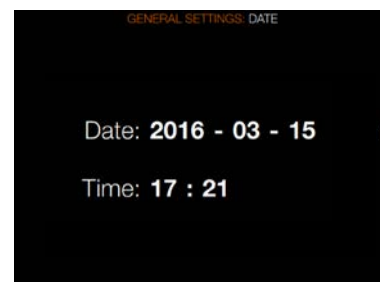

Set Date and Time

- 1 Press the General Settings icon on the Sensor unit display.
- 2 The General Settings Menu will appear.
- 3 Press the Date and Time icon.

Swipe right or press Menu / EXIT button to get back to Main Menu.

Date and Time Menu Settings

Date

Set Date by changing year, month and day using the pop up menus.

Time

Set Time by changing hour and minute using the pop up menus.

4.6 SET LANGUAGE

MAIN MENU > GENERAL SETTINGS > LANGUAGE

Main Menu



General Settings Menu

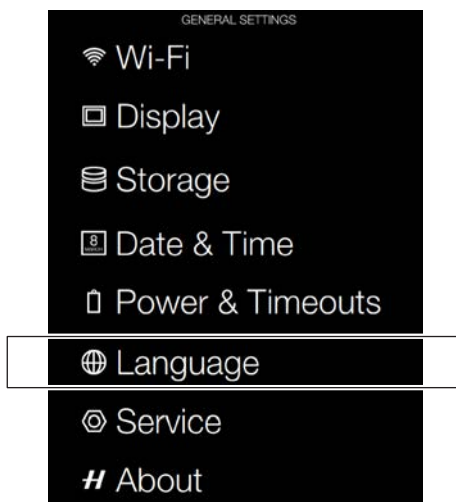

Language Menu



Language Menu Settings

More language options will be added in a future Firmware release.

Available Language:

- English

- 1 Press MENU button on the Sensor Unit Display.
- 2 Navigate to General Settings.
- 3 Navigate to Language.
- 4 Select Language.
- 5 Close the pop up Menu by a click outside the pop up.

Note!

If the sensor unit has been set to a language you don't understand (a rented camera, for example), see Chapter Troubleshooting for solution.

4.7 SET BRIGHTNESS OF THE DISPLAY

MAIN MENU > GENERAL SETTINGS > DISPLAY

Main Menu



General
Settings icon

General Settings Menu

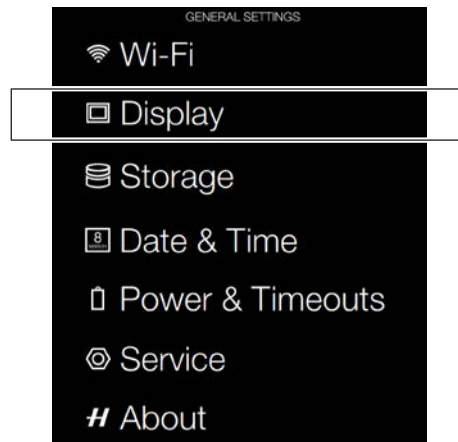

Display Menu

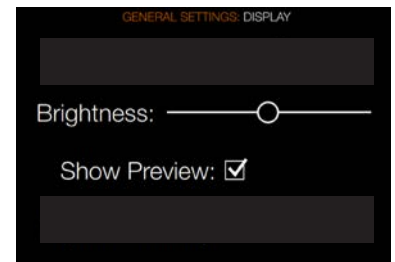

Set Display Brightness

- 1 Press the Settings icon on the Sensor Unit Display.
- 2 The General Settings Menu will appear.
- 3 Select Display.

Swipe right or press Menu / EXIT button to get back to Main Menu.

Display Menu Settings

Brightness

Slide Left or Right to change Brightness.

Show Preview

Select On / Off. On displays a preview of the capture after every exposure.

4.8 INSERT A MEMORY CARD (CFast OR SD)

There are two types of memory cards that can be used with the H6D camera. CFast card and SD card.

Insert CFast card

- 1 Open the CFast and SD card slot cover on the sensor unit by pushing it to the left or towards the back of the camera. The slot cover will then rotate out 90 degrees.
- 2 Insert a thumb in the recess and then slide it to the left. Behind the cover, there is a slot for the CFast card (A).
- 3 Hold the CFast card so that the connector holes face into the slot and you can read the brand label when you are behind the camera. Gently press the CFast card into the slot. If you encounter resistance, ensure you are not holding the card backwards or upside down.
- 4 If the card can be easily inserted nearly all the way into the back, you are inserting it correctly. Press the card another couple of millimetres firmly into place.
- 5 Close the slot cover by rotating it back and pushing it in place towards the front of the camera to lock it into position.



Insert SD card

- 1 When the card slot cover door is opened, mount the SD card in the SD card slot (B).
- 2 Close the slot cover by rotating it back and pushing it in place towards the front of the camera to lock it into position.

Currently approved cards

CFast:

- SanDisk Extreme PRO CFast 2.0
- Lexar Professional 3400x CFast 2.0

SD:

- Sandisk Extreme PRO SDHC/SDXC UHS-I

For an updated list, please check www.hasselblad.com.

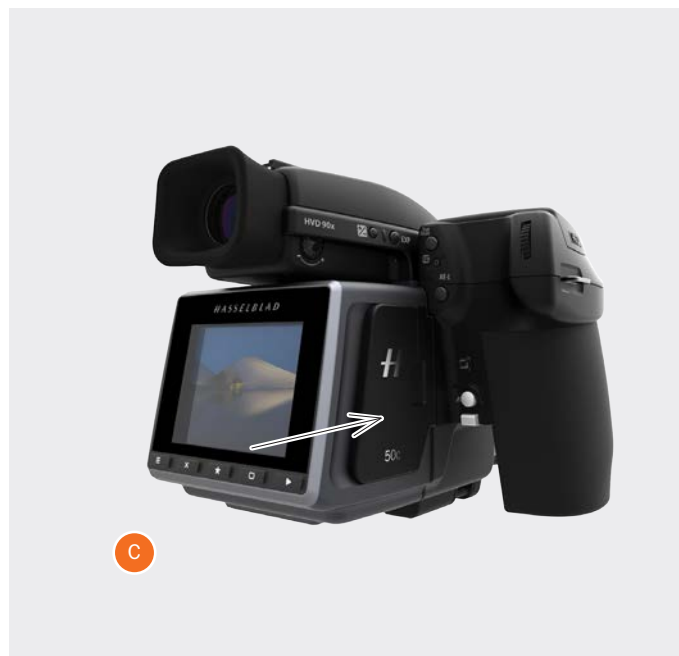

4.9 REMOVE A MEMORY CARD (CFAST OR SD)

Remove CFast card

- 1 Open the CFast and SD card slot cover on the sensor unit (A) by pushing it to the left or towards the back of the camera. The slot cover will then rotate out 90 degrees.
- 2 Press the CFast card (B) a little way in and then release it. The CFast card will then move out from the CFast card slot (B).
- 3 Grab the card and pull it away from the sensor unit.
- 4 Close the slot cover (D) by rotating it back and pushing it in place towards the front of the camera to lock it into position.

Remove SD card

- 1 Open the memory card slot cover on the sensor unit (A).
- 2 Press the SD card (C) a little way in and then release it. The SD card will then move out from the SD card slot (C).
- 3 Grab the card and pull it away from the sensor unit.
- 4 Close the slot cover (D) by rotating it back and pushing it in place towards the front of the camera to lock it into position.

Note!

Do not remove a memory card from the sensor unit if the 'ready' light is blinking (placed in the lower right corner on the Sensor Unit Display), as this will corrupt the files on the card and result in data loss. The card will also need to be reformatted.



To Prepare

4.10 FORMAT A CFAST CARD

MAIN MENU > GENERAL SETTINGS > STORAGE > FORMAT

The camera is only able to read and write to storage media that have been formatted correctly. New cards sometimes have no formatting, or you might want to convert a card that is currently using a format that the camera cannot read. In either case, you must reformat both CFast cards and SD cards in the sensor unit for H6D use.

There are two ways to format cards. The quickest way is to use the Format card button on the grip but if you prefer, you can also use the menu on the sensor unit.

FORMAT BUTTON

Press the Format button (A) on the camera grip. It is purposely recessed to avoid unintentional use, so use a ballpoint pen or similar. A prompt is displayed on the sensor unit for confirmation.

FORMAT MEMORY CARDS VIA SENSOR UNIT

MAIN MENU > GENERAL SETTINGS > STORAGE > FORMAT

Use the Rear scroll wheel or navigate via the touch screen and the dedicated 5 buttons under the Sensor Unit Display.

- 1 Press MENU.
- 2 Navigate to Storage
- 3 Navigate to Format
- 4 Navigate to Format CFast or SD card.
- 5 Confirm by pressing OK (Display button).

Note!

The H6D is capable of writing 78 MB/s to SD card and up to 400 MB/s to CFast cards.

Note!

All CFast and SD memory cards should be formatted in the sensor unit before using them the first time.



Storage Menu

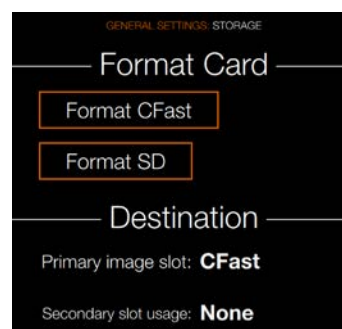

4.11 SET DRIVE MODE

There are two drive modes: Single drive and Continuous drive.

Long press on ISO button (D) toggles between Single drive and Continuous drive mode. It can also be set from Main Menu or Control Screen.

In Single mode, a capture is made when the shutter release button is pressed and the camera is made ready for the next capture.

To make the next capture however, you must first release the shutter release button and then press again.

In Continuous mode, the camera automatically makes captures and makes ready for the next capture in a continuous manner as long as you maintain pressure on the shutter release.

Please note the speed is dependent on the time taken to save the capture according to equipment.

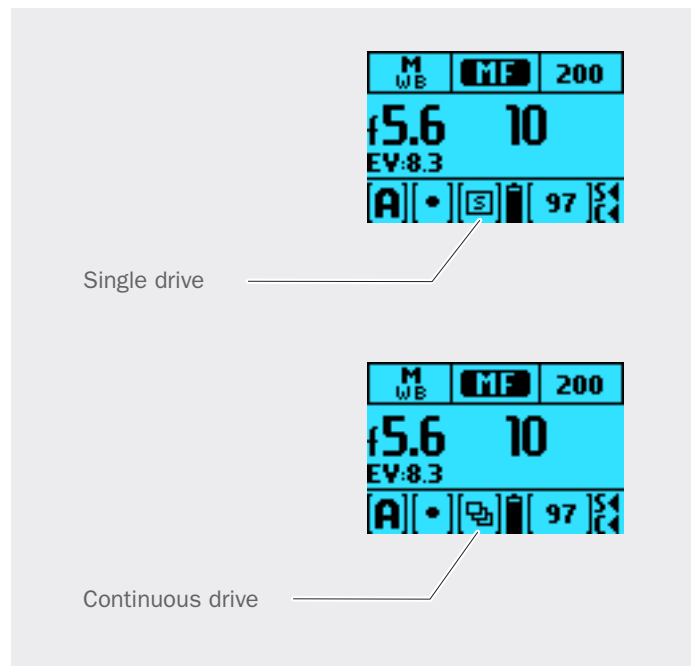
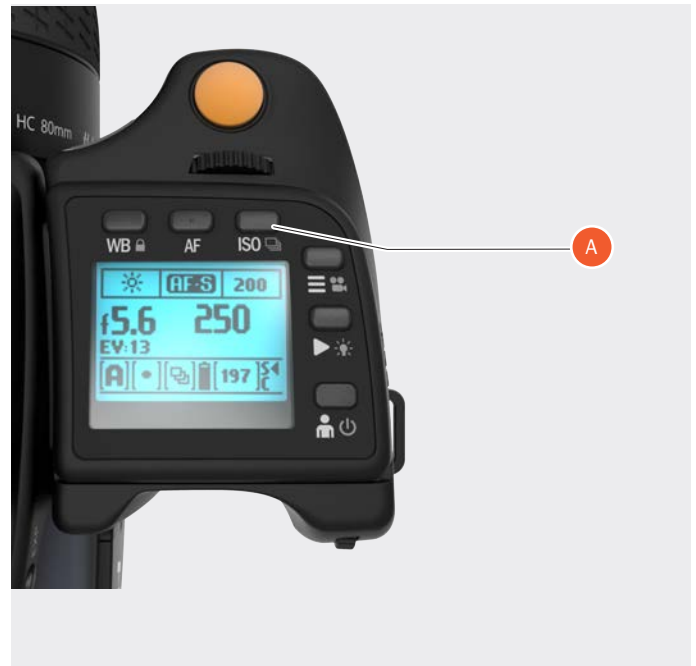

5.1 NAVIGATING THE MENUS

DESCRIPTION OF THE SENSOR UNIT MENU ITEMS

The H6D Sensor Unit Screen is Touch Sensitive and you can swipe with one finger in different directions to move up, down, forward and backward through the user interface.

Button	Screen function
1 MENU / (EXIT) button	Back to Main Menu
2 Soft button	Up
3 Image rating button	Select
4 Soft button	Down
5 Browse button	Go to image browse

1 MENU / (EXIT) button

This button opens the Main Menu. It is also used for other tasks (for example EXIT button) as you issue commands navigating the menu system.

2 Soft button

Function depends on screen information. Also acts as Delete Image button in Browse Mode.

3 Image rating button

Rate image 1-5 stars or green/yellow/red. Also works as soft button. Also toggles between 1-view and 9-view in Browse Mode.

4 Soft button

Function depends on screen information

5 Browse button

Starts display and shows the last image. The user can review images, browse and zoom. Preview images and zoom in to view close-ups of previews for focus checking. Zoom out to view several at once and finally to view and select folders and media.

By using the buttons on the control panel and the scroll wheels on the grip you can navigate through the various levels in the menu. Here is an overview of the setting options available.

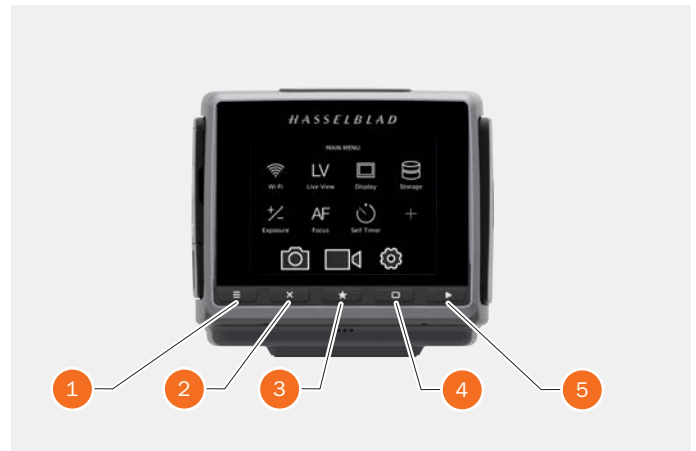

Control Screen

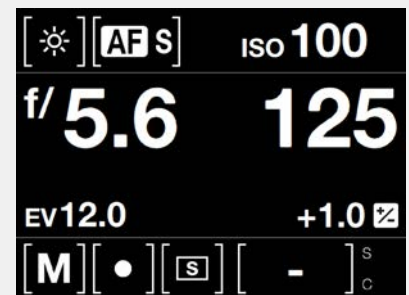

Main Menu

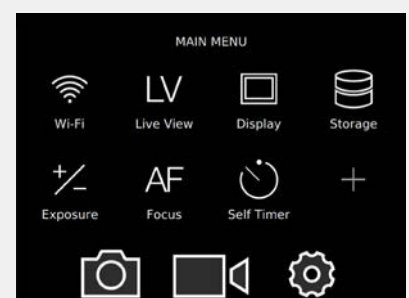

OVERVIEW OF MENUS AND SETTINGS ON SENSOR UNIT

The Sensor Unit Display can be controlled directly on the touch sensitive screen by pressing the menus and icons. You can scroll up, down and from left to right as described in previous chapters. You can also navigate the on screen menus by using the following buttons and scroll wheels:

- A Control buttons under the Sensor Unit Display for example Menu / Exit button
- B Front Scroll Wheel
- C Rear Scroll Wheel
- D True Focus Button
- E AE-L Button

The Main Menu on the Sensor Unit Displays:

Camera Settings, Video Settings and General Settings. Above them the Favourite Settings Short Cuts are displayed. You can add or delete these Short Cuts to access your most used functions directly from the Main Menu for better work flow.

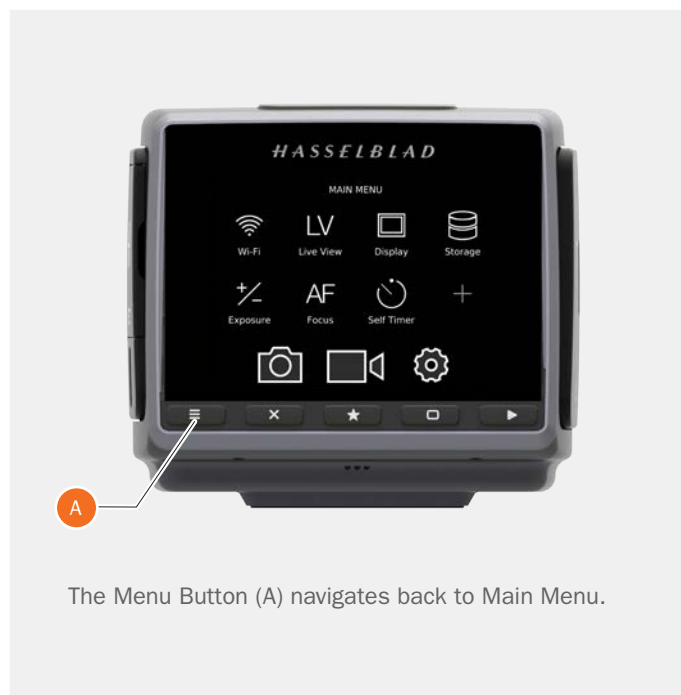

To Use

USER GUIDE

TOUCH SCREEN NAVIGATION

The Touch Screen on the H6D Sensor Unit is similar to a Phone or Tablet with touch sensitivity. The following gestures can be used to navigate and control the camera:

Action	Function
Swipe Right	Move back / Move image right.
Swipe Left	Move image left. Only in Browse mode.
Swipe Down	Display Control Screen.
Swipe Up	Hide Control Screen.
Tap / Press	Select action / button / setting.
Double Tap	Zoom in to 100%. Double Tap again to Zoom out to full View.

Function	Action
Select	Tap / Press with one finger.
Display Control Screen	Swipe down from the top of the screen.
Hide Control Screen	Swipe up.
Move back	Swipe right.
Zoom in	Spread (move two fingers apart).
Zoom out	Pinch (move two fingers together).

Display Control Screen from Main Menu

- 1 Swipe down over Main Menu to display the Control Screen. Swipe down by starting on the upper part of the Sensor Unit Display near the top edge.
- 2 The Control Screen displays the Camera Settings.
- 3 The Control Screen is interactive, select any of the settings to make a quick adjustment within the Control Screen Interface.
- 4 Swipe Up to hide the Control Screen and display the Main Menu.

Swipe Right



Swipe Left



Swipe Down

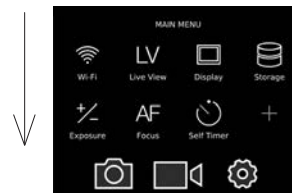

Swipe Up



Swipe Down

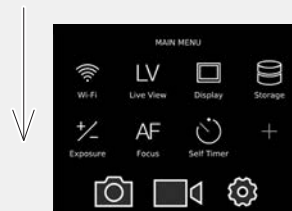

Main Menu



Control Screen

Swipe Up

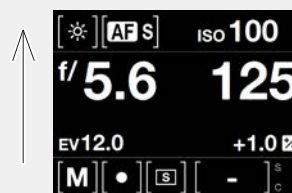

Control Screen



Main Menu

5.2 SENSOR UNIT DISPLAY NAVIGATION

MAIN MENU

In the Main Menu you will find the following options.

- 1 Camera Settings
- 2 Video Settings
- 3 General Settings

Wi-Fi
Live View mode
Display
Storage
Exposure
Focus
Self Timer

+ (Plus) Add your own function by selecting the + icon.

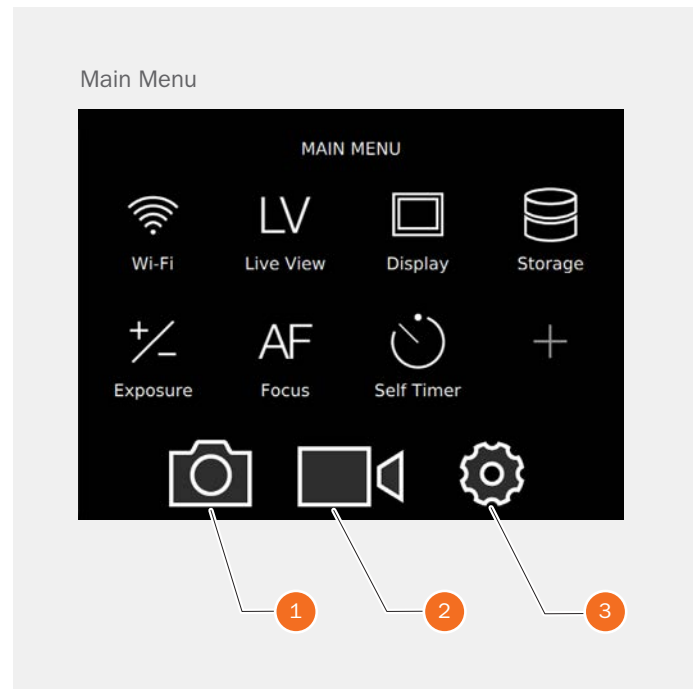

CONTROL SCREEN

Display Control Screen

Swipe down from the top of the display on the Sensor Unit Display or press the left soft button under the display you can always display the Control Screen.

Close the Control Screen

Swipe up from the top of the display on the Sensor Unit Display or press the left soft button again under the display you can always display the Control Screen.

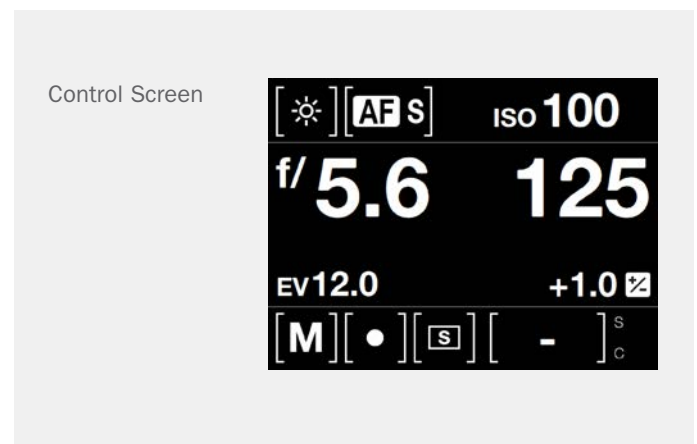

CONTROL SCREEN DESCRIPTION

The Control screen is a quick way to adjust settings. Tap / Select the desired function and change the setting directly in the Control Screen.

Locked Values on the Control Screen

P and Pv Mode

When you select P or Pv, the Aperture (5.6) and Shutter (125) are automatic and displayed in grey colour that indicates that you cannot change these settings.

A Mode

For Aperture priority (A) you can change the Aperture value and the Shutter value will be automatic and displayed in grey.

S Mode

For Shutter priority (S) you can change the Shutter value and the Aperture value will be automatic and displayed in grey.

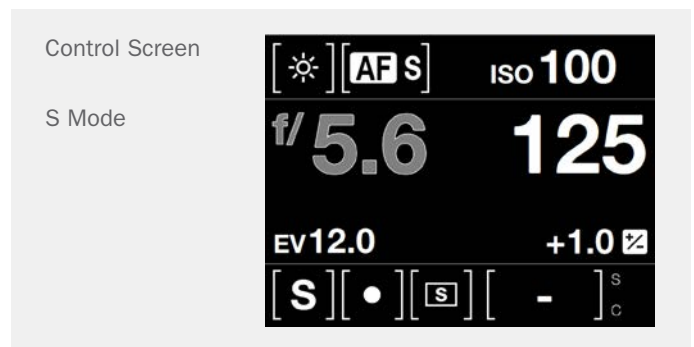
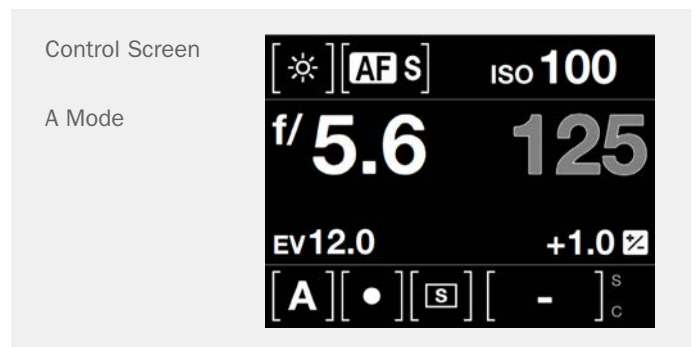
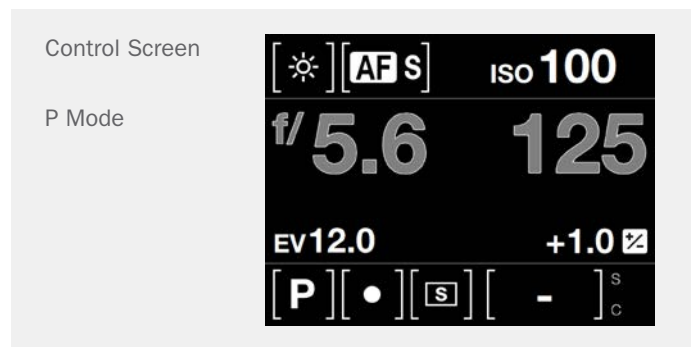
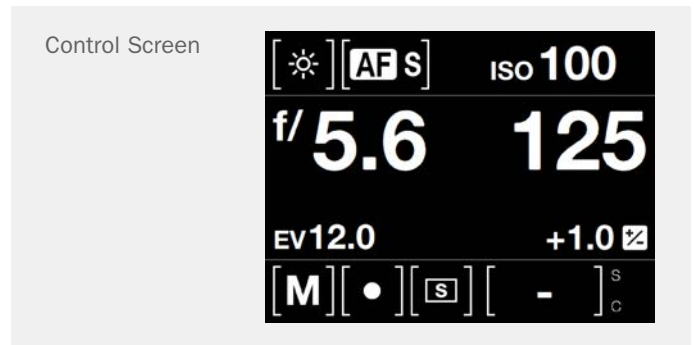

Settings on the Control Screen

White Balance

- Cloudy
- Shade
- Daylight
- Tungsten
- Flourescent
- Flash
- Manual

AF Focus

- AF-S Single Focus
- AF-C Continuous Focus
- AF-T True Focus
- MF Manual Focus

ISO

- Select ISO value.

Aperture

- Select Aperture value.

White Balance

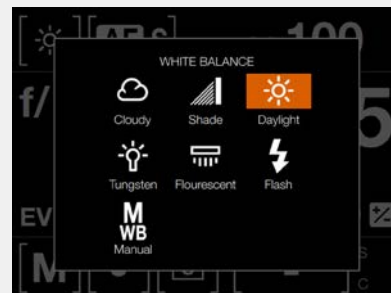

AF Focus

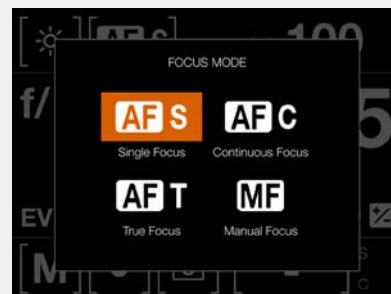

ISO

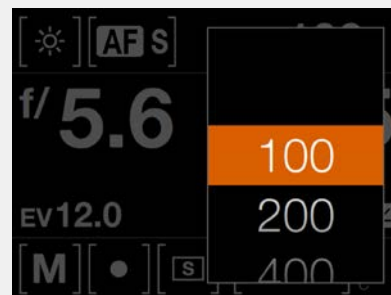

Aperture

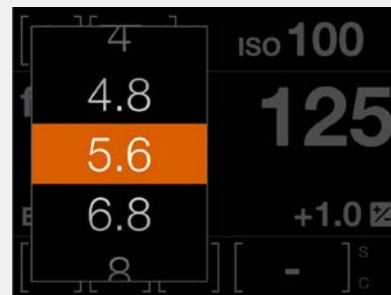

This Chapter continues on the next page.

Settings on the Control Screen

Shutter

- Select Shutter value.

Exposure Adjust

- Adjust Flash Exposure by sliding right (+) or left (-).
- Adjust Exposure by sliding right (+) or left (-).

Exposure Mode

- M Manual
- A Aperture Priority
- S Shutter Priority
- P Program
- Pv Program Variable

Metering Mode

- Center Weighted
- Spot Weighted
- Center Spot Weighted

This Chapter continues on the next page.

Shutter



Exposure Adjust

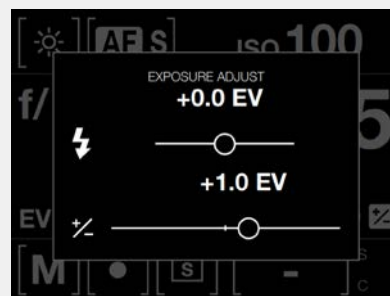

Exposure Mode

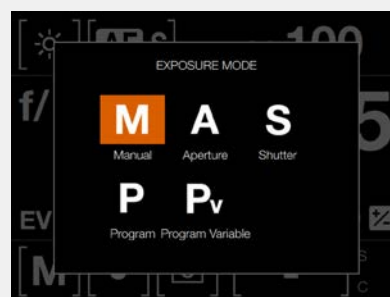

Metering Mode

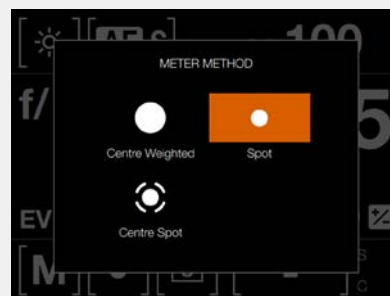

Settings on the Control Screen

Drive Mode

- Single Drive Mode
- Continuous Drive Mode

Remaining Captures

- Displays the number of remaining Captures.

Memory Card

- S for SD Card
- C for CFast Card

Drive Mode

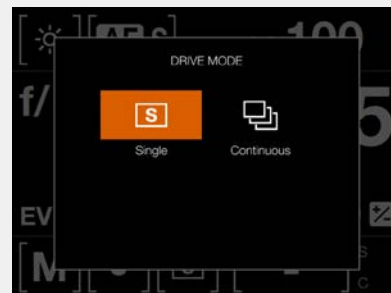

Remaining Captures

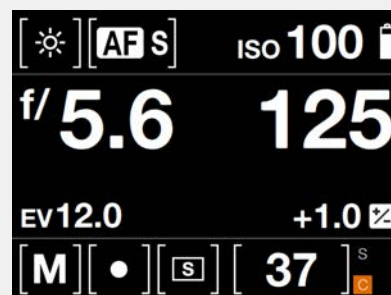

Memory Card

S - SD Card.

C - CFast Card.

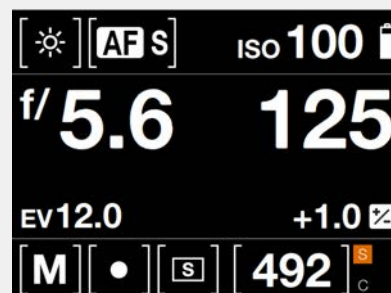

Settings on the Control Screen

ADD AND REMOVE FAVOURITE FUNCTIONS TO CONTROL SCREEN

- 1 Add a favourite function by selecting the + icon (1) on the Main Menu.
- 2 Remove a function from the Control Screen by a long press on the icon to be removed.

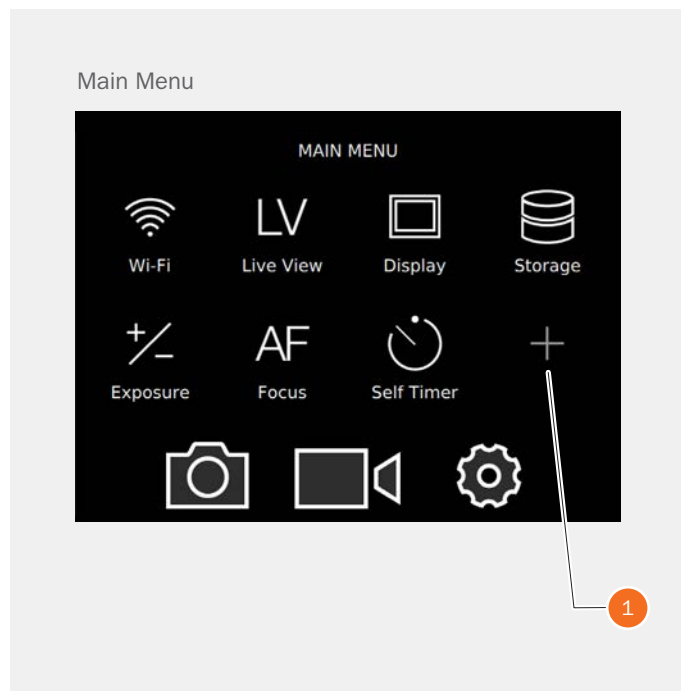

5.3 CAMERA SETTINGS MENU

Main Menu

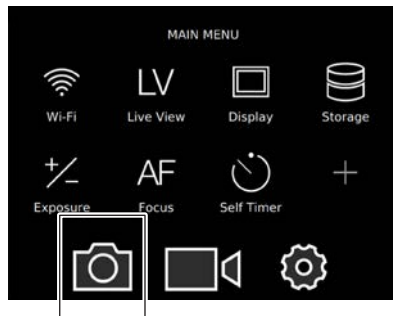

Camera icon

MAIN MENU > CAMERA SETTINGS

Press the Camera icon on the Sensor unit display. The Camera Settings Menu will appear.

Swipe right or press Menu / EXIT button to get back to Main Menu.

Camera Settings Menu

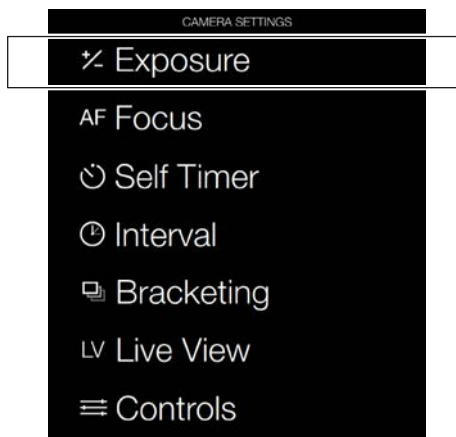

Exposure Settings Menu

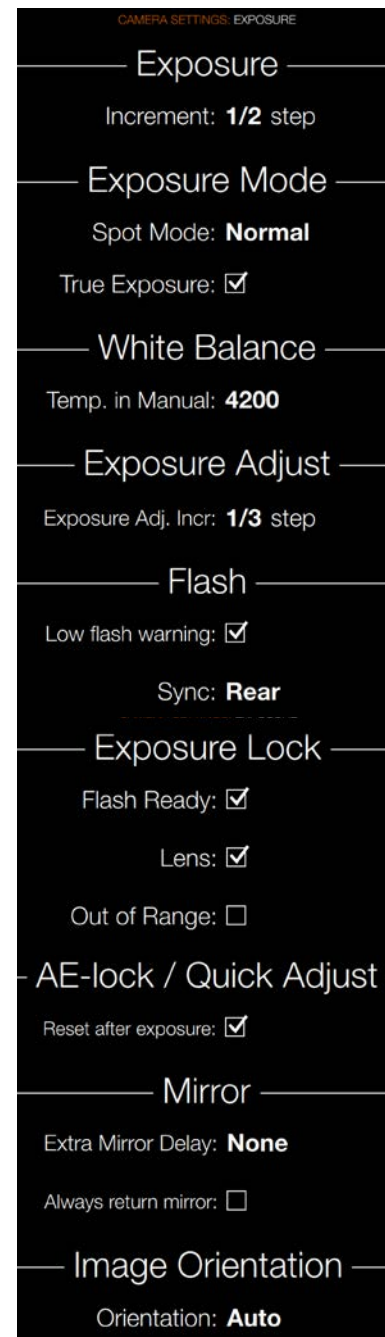

5.4 CAMERA EXPOSURE SETTINGS

MAIN MENU > CAMERA SETTINGS > EXPOSURE

Press the Camera icon on the Sensor unit display. The Camera Settings Menu will appear.

Press the Exposure Settings Menu.

Swipe right or press Menu / EXIT button to get back to Main Menu.

Exposure Settings

Increment

Select the Increment setting.

Camera Menu

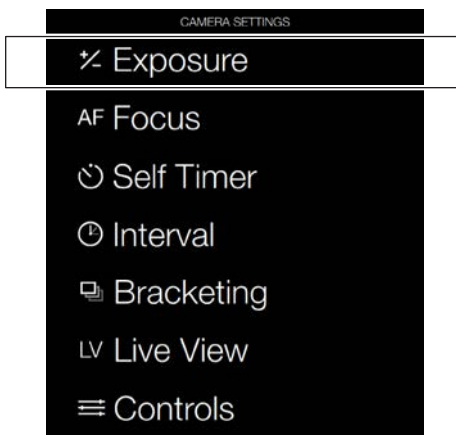

Exposure Settings Menu

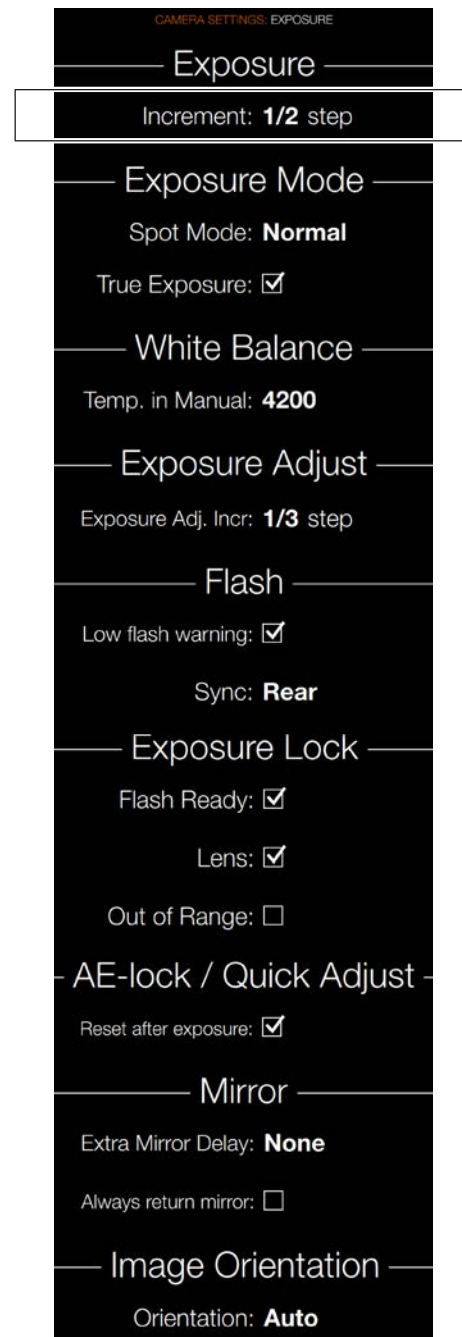

ISO AND WHITE BALANCE

ISO and White Balance are set either via the Grip, the Sensor Unit Display or, when tethered, via Phocus.

- On the grip, the WB (B) and ISO button (C) provides immediate access to ISO and White Balance settings. The front scroll wheel (A) and rear scroll wheel (D) are used to make the desired changes. These appears on the grip display, the sensor unit display and in the viewfinder.
- For the sensor unit display, settings are changed on the touch display or via the soft buttons under the display.
- In Phocus there is a specific tool to control camera settings.

The settings are automatically and simultaneously transferred from the grip to the sensor unit. Likewise all changes on the sensor unit are automatically transferred to the grip display.

Please note that the changes are only displayed on the sensor unit when the settings have been saved.

See more information about making manual white balance settings in the 'Sensor Unit Settings' section.



ISO AND WHITE BALANCE ON GRIP

ISO

- 1 Press ISO button (D).
- 2 Turn the Front scroll wheel (A) to select ISO setting.

White Balance WB

- 1 Press WB button (B).
- 2 Turn the Front scroll wheel (A) to select WB (Daylight, Shade, Cloudy, Flash, Fluorescent or Tungsten).
- 3 To set the Colour Temperature manually, scroll the Front Scroll Wheel until “M” is displayed. Then the colour temperature value is displayed at the bottom of the screen.

Note!

White Balance settings are technically not necessary for 3F/3FR files. The raw format files contain all the information required for correction in Phocus and/or other software, regardless of the original colour temperature of the light source or colour temperature setting of the camera at the time of exposure. If you intend to shoot RAW & JPEG or use Phocus for JPEG production and plan to deliver or print the JPEG files directly, then you should make a White Balance setting.

Note!

ISO and White Balance settings are made either on the grip or the sensor unit. The settings are automatically updated on both.

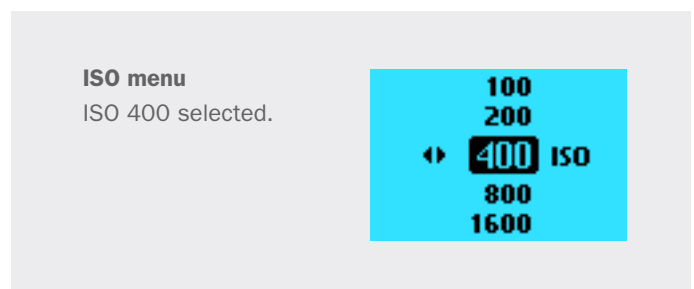
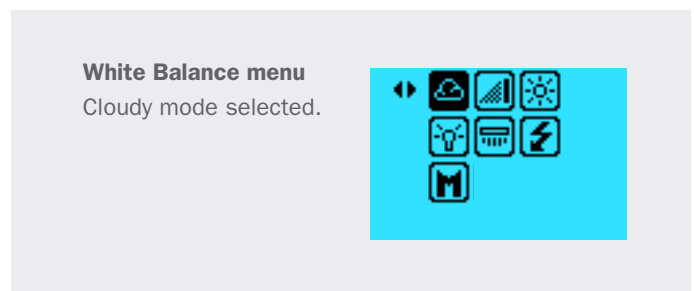
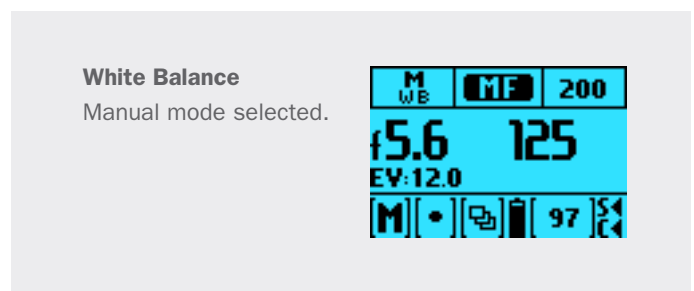

EXPOSURE SETTINGS MODES

MAIN MENU > CAMERA SETTINGS > EXPOSURE

Press the Camera icon on the Sensor unit display. The Camera Settings Menu will appear.

Press the Exposure Mode Settings Menu.

Swipe right or press Menu / EXIT button to get back to Main Menu.

Here you can only select the Spot Mode and set True Exposure On or Off.

To change the Exposure mode Swipe Down to display the Control Screen or press the EXP button on the Viewfinder.

Exposure are controlled either manually or by using one of four automatic modes. These have the following designations on the grip display:

- M – Manual
- A – Aperture (priority)
- S – Shutter (priority)
- P – Program
- Pv – Program variable

In each mode you can see both the aperture and the shutter speed information on the grip display, viewfinder display and if set, the sensor unit display.

In manual mode, aperture is set by the front scroll wheel and the shutter speed by the rear scroll wheel unless set otherwise in Camera Settings > Controls > Front Wheel.

In the automatic modes, the aperture and shutter speed settings are controlled by the camera, either partially or completely according to setting. Within this mode there are four choices.

Note!

Please see the Appendix for P and Pv mode charts that describe the aperture and shutter speed setting combinations.

Exposure Settings Menu

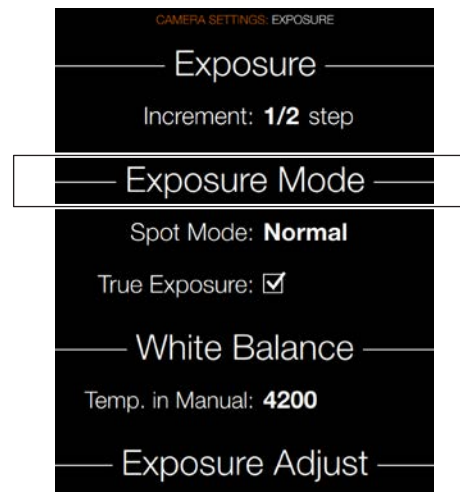

Grip Display View

Exposure settings on Grip Display.



SELECT METERING / EXPOSURE SETTING MODES

Proceed as follows with the camera in active mode:

- 1 Press the EXP button on the viewfinder.
- 2 Turn the Rear scroll wheel to make a Metering method selection and the Front scroll wheel to make an Exposure method selection.
- 3 Press the EXP button again or half press the exposure trigger button to leave the menu.

MANUAL EXPOSURE MODE

To change the Exposure mode Swipe Down to display the Control Screen or press the EXP button on the Viewfinder.

Manual mode provides total user control of the shutter and aperture settings. In this mode the shutter speed and aperture settings are manually chosen by turning the front and rear scroll wheels.

The standard exposure setting is obtained when the pointer over the exposure scale is positioned above the central index (in the viewfinder display).

Any deviation from this standard setting is displayed by:

- the pointer appearing elsewhere than above the central index
- by figures above the scale representing the amount of adjustment in EV's.

A '+ 0.7' above the scale in the display, would indicate a '0.7 EV overexposure' setting. Conversely, a '-2', for example, would indicate a '2EV underexposure' setting. Note that the appearance of a +/- symbol on the grip and viewfinder displays in manual mode means that a change has been made to the exposure compensation setting. See later section on Exposure compensation.

The actual aperture settings and shutter speeds are indicated to the right of the exposure scale in the conventional manner. (Note: 'full-stops', 'half-stops' and 'third-stops' are also displayed, according to setting (see increment setting). For example, a setting between f/8 and f/11 will appear as f/9,5 if 'half-stop' is chosen).

Exposure Modes

Grip Display.



Exposure Modes

Sensor Unit Display.



AUTOMATIC EXPOSURE MODE

To change the Exposure mode Swipe Down to display the Control Screen or press the EXP button on the Viewfinder.

Automatic exposure provides a choice of two ways to control the shutter speed and aperture settings semi-automatically and two ways fully automatically:

Aperture priority A

The aperture is manually chosen by you by turning the front scroll wheel, and the shutter speed is automatically chosen by the camera.

Shutter priority S

The shutter speed is manually chosen by you by turning the front scroll wheel, and the aperture is automatically chosen by the camera.

Programmed P

In this mode, an aperture/shutter combination is chosen by the camera according to the EV measured (metering method remains as your choice), though only within pre-set appropriate limitations to suit various requirements and applications.

Programmed variable Pv

This mode is very similar to Programmed, except with the additional parameters of lens focal length being automatically taken into account. For example, long shutter speeds will automatically be avoided with a long focal length lens (see illustration on the following page).

In Automatic mode the front scroll wheel selects alternative aperture/shutter combinations while maintaining the same EV and the rear scroll wheel alters the amount of exposure compensation. The compensation appears as a +/- symbol on the grip display and viewfinder display.

Note!

Aperture and shutter speed settings can both be changed even while the busy light on sensor unit is flashing.

Exposure Modes

Grip Display.



Exposure Modes

Sensor Unit Display.



AUTOMATIC EXPOSURE - P AND PV MODE

P Mode

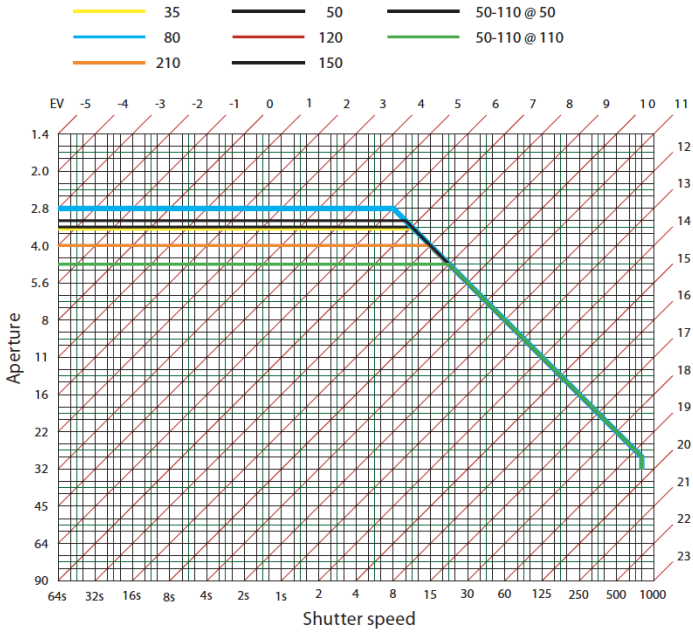

Pv Mode

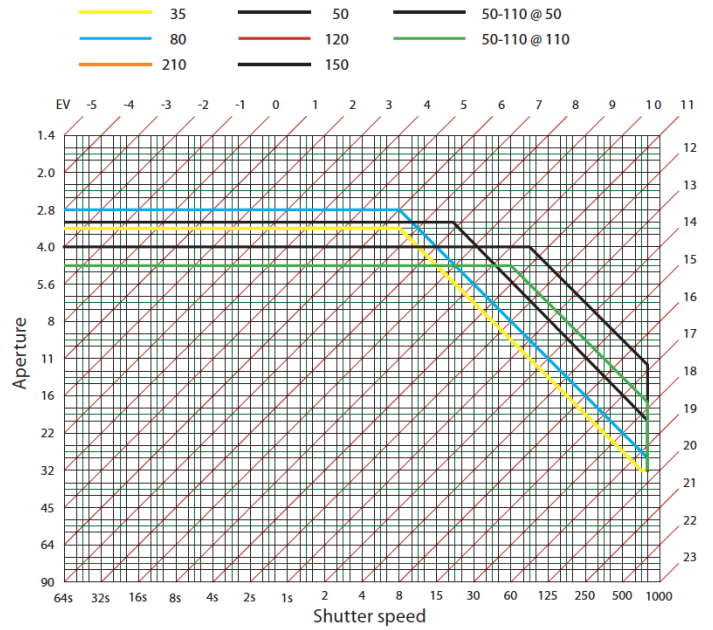

AE-L BUTTON

The AE-L button (A) has two main functions that can be incorporated in various working methods involving exposure locking. It also has an extra function for the flash measure capability (see AE-L section under Flash). The AE-L button can:

Lock an EV setting in manual and automatic modes

When the button is pressed, the light metering facility is locked to the EV setting at that moment. An L (=locked) symbol appears between the shutter speed and the aperture indication on the grip display and viewfinder display to confirm the status. Press the AE-L button again to unlock (a toggle function).

In the locked setting, the aperture and shutter speed become interlocked. In this way, a new aperture/shutter combination that still represents the same EV, can be rapidly chosen. For example, if the shutter is set to 1/125s and the aperture to f/8 and are locked together, you can access new EV-equivalent combinations of, for example, 1/30s at f/16 or 1/500s at f/4 just by moving the front scroll wheel.

In practice this means you can, for example, in auto mode position the metering area (spot setting) over an area in the subject that you determine to be equivalent to a mid-grey and lock it with the AE-L button. You can then recompose the picture with the metering zone positioned over an area much brighter or darker while still retaining the original exposure setting and choose a new combination of aperture and shutter speed settings.

Be used as a Zone System placement button

The AE-L button also allows the spot metering function to make zone placements. When the AE-L button is pressed, the metered area is saved as a mid-grey (Zone 5). When the spot area is then placed over another part of the scene, the new area is then compared to the saved area and the difference can be read off the scale seen in the viewfinder. For example, in a landscape situation you could meter the foreground, lock the reading with the AE-L button (thereby locking that area to be reproduced as the equivalent to a mid-grey 18%), point the camera at some rocks to see by how much darker they are compared to the foreground by the EV difference read off the scale.

If you have chosen Spot together with Zone display as well as one of the automatic modes A, S, P or Pv, point the spot marking at an area that you decide should be a Zone 5 and click the AE-L button. The meter will now display different parts of the subject as zone values in the viewfinder display, instead of EV deviations, as you move the spot marking over the subject. (Included are Lo and Hi to signify areas beyond the range of the sensor).

Alternatively you can choose to re-classify an area as another



Grip Display View
Lock

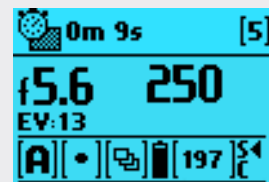

zone and then check the rest of the subject to see how other areas fall on the zone scale. Do this by following the above procedure and then turning the rear scroll wheel until you see the new desired zone value in the viewfinder display. You will also see the new exposure that will now produce that new zone. For example, you might have measured a rock at zone 5 but wish to make it darker. By moving the rear scroll wheel you could re-classify it as zone 4. You will then be able to see, for example, whether white clouds are now falling within the exposure range by their new zone classification.

Alternatively, you can also pre-set the initial zone reading in order to save time and effort where there is no freely available 'zone 5' subject for light measuring. For example, you might be on a sandy beach where you know that sand is normally classified as zone 6. You can pre-programme the zone placement by holding down the AE-L button while choosing the new zone value and turning the front scroll wheel until zone 6 appears. All new placements will then be zone 6.

FIXED EXPOSURE COMPENSATION SETTING

- 1 Press the '±' button on the viewfinder (A).
- 2 Turn the Front Scroll Wheel (B) to change the Flash compensation and the Rear Scroll Wheel (E) on the grip to increase or decrease the amount of Exposure Compensation in 1/3 EV steps.
- 3 The amount is displayed in the viewfinder as both an EV figure complete with a 'minus' or 'plus' prefix (A in illustration), and as a marker above a 'minus' to 'plus' scale.
- 4 Press (C - AF Button) to reset any compensation back to zero.
- 5 Press Save (D - ISO Button) to retain the setting.
- 6 A '±' symbol is then displayed between the aperture and shutter speed setting as confirmation of the setting.



Viewfinder Display View

Exposure compensation EV +1.3



Grip Display View

Flash Exposure

Camera Exposure

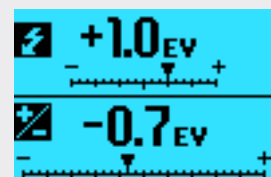

LIGHT METER EXPOSURE MODE

The Light Meter Exposure Mode can be changed on the Control Screen or by pressing the EXP button on the Viewfinder. Use the Rear Wheel to select.

Different Light Metering Modes

There are three reflective metering modes available.





Center Weighted

Center Spot

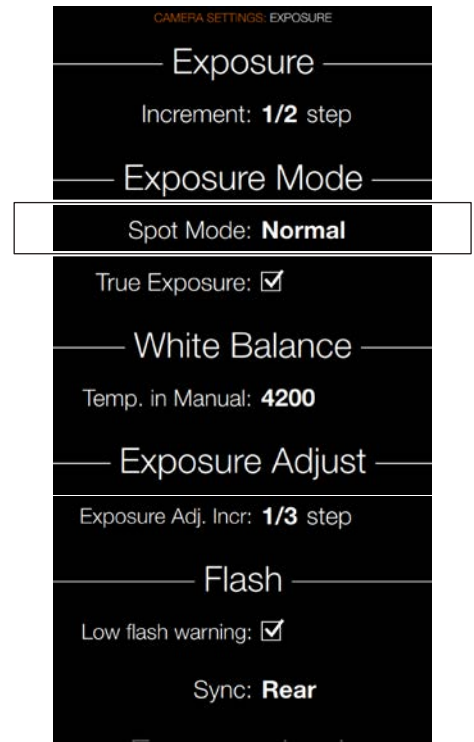
Spot

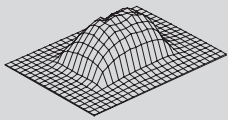
Exposure Settings Menu

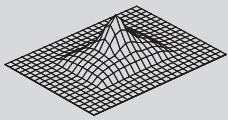

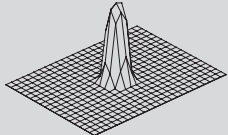
Light metering mode	Description	
Center Weighted	 	Used for light situations where there is no particular dominance of light or dark areas across the tonal range. Takes into account approximately 25% of the image seen in the viewfinder.
Center Spot	 	Emphasizes the central section of the focusing screen equivalent to approximately 25% of the image. This provides a balanced assessment and is a typical choice where the main subject is in the centre of the image.
Spot	 	The sensitive area is equivalent to approximately 2.5% of the image area (the central spot on the viewfinder screen). Any parts of the image outside of this area will not affect the exposure reading. This provides a very accurate measurement of specific tones. Typically used in the zone system and similar light measuring situations where maximum control is required. Also excellent for tonal comparison measurements. The spot mode can display 'zones' instead of EV's in the viewfinder display.