

SPECIFICATION FOR APPROVAL

CUSTOMER: **SZ003**

CUST P/N: **1031.00285**

FINE P/N:

DESC: **FYSZ00312024010901S**

DATE: **2024/01/09**

Version: **A.0**

PREPARED BY	CHECKED BY	APPROVED BY	CUSTOMER APPROVE
IVY	CAI jyu	Ding Baoyuan	

Dongguan FANYA Electronics Co., LTD

Factory address: No.194, Liuwu Technology East Road, Shijie Town, Dongguan City.

TEL: 0769-22490287 / 22452492

FAX: 0769-22499451

E-mail: fineelec@163.com

SPECIFICATION

DESC	FYSZ00312024010901S	Rev: A.0	CUST:	SZ003
			Fine P/N:	FYS003088
			CUST P/N:	1031.00285

一、 DIMENSION:(mm)

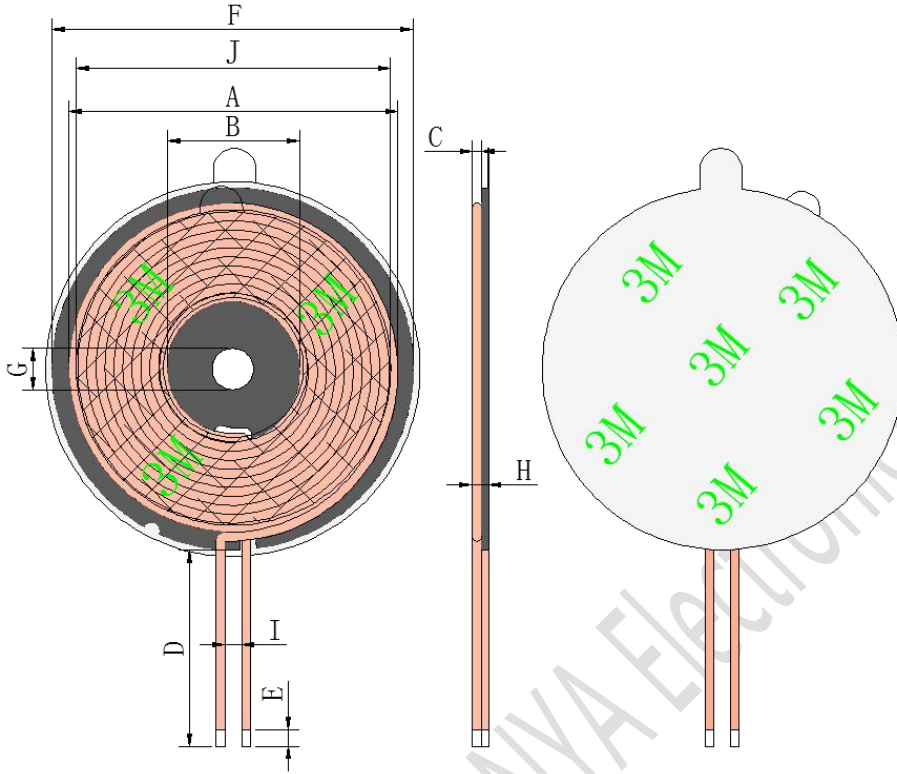

A	40±1.5
B	16±0.5
C	1.2 +0.05/-0.1
D	25±1.5
E	2±1.5
F	43.9±0.5
G	5 ref
H	2.3 Max (Excluding shaped paper)
I	2±1
J	38±0.5

pour:

1. The coil cross line, the starting line needs to be flattened;
2. Back coil hard magnetic sheet, magnetic sheet size $\phi 43.9 \pm 0.5$ mm, open hole $\phi 5$ mm ref, thickness 0.7 ± 0.1 mm, open L double line slot;
3. Attach $\phi 46 * 0.05$ mm with hand tear 3M55256 glue (green 3M glue) on the back of the magnetic piece, and attach $\phi 38 * 18 * 0.05$ mm with hand tear green 3M glue on the front of the coil.

二、 SCHEMATIC DIAGRAM:

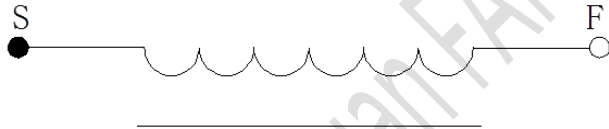

三、 Winding Specification:

NO.	TERMINAL		WIRE	Turns	Winding Direction
	S	F			
1	S	F	silk-covered wire 0.08*105	11Ts	CCW

四、 ELECTRICAL CHARACTERISTICS: TEMPERATURE: $25 \pm 10^\circ\text{C}$, RELATIVE HUMIDITY: $65 \pm 20\%$

NO.	ITEM	TERMINAL	SPECIFICATION	TEST FREQUENCY	TEST EQUIPMENTS
1	IND.	S-F	$6.5\mu\text{H} \pm 10\%$ Add magnetic sheet	100KHz/1.0V	TH2829LX
2	DCR	S-F	$\leq 50\text{m}\Omega$	@25°C	TH2829LX

PREPARED BY/DATE	CHECKED BY/DATE
IVY 2024/01/09	CAI jyu 2024/01/09

SPECIFICATION

DESC	FYSZ00312024010901S	Rev: A.0	CUST:	SZ003
Fine P/N:			FYS003088	
CUST P/N:			1031.00285	

五、PACKING:

5.1 Packing pictures:

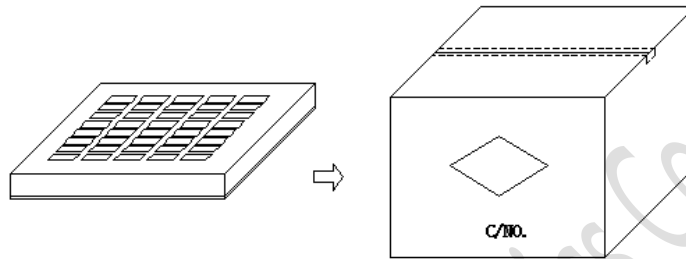

5.2 Packing Quantity:

Item	Quantity	Material
Box	200 Pcs	370*265*55mm
Big Carton	1000 Pcs	420*270*310mm

5.3 The packaging shall be based on the existing packing plate and the actual delivery package shall prevail. If there is any requirement, we can customize it.

六、Material list:

number	Material name	Description	Manufacturer
1	silk-covered wire 0.08*105	0.08*105	
2	No lead tin strip	No lead tin strip	
3	magnetic sheet	Magnetic sheet size $\phi 43.9 \pm 0.5\text{mm}$, open hole $\phi 5\text{mm}$ ref, thickness $0.7 \pm 0.1\text{mm}$, open L double line groove	
4	3M55256 of glue	$\phi 46 * 0.05 \text{ mm}$ with 3M55256 tape	
5	3M55256 of glue	$\phi 38 * 18 * 0.05\text{mm}$ Remove 3M55256 glue with hand	
6			

PREPARED BY/DATE	CHECKED BY/DATE
IVY 2024/01/09	CAI jyu 2024/01/09