

FCC Test Report

Report No.: RFAQOT-WTW-P21080808

FCC ID: 2AEEV-OBFTC-0090-A

Test Model: OBFTC-0090-A

Received Date: Aug. 20, 2021

Test Date: Aug. 26 ~ Aug. 27, 2021

Issued Date: Nov. 11, 2021

Applicant: Otter Products, LLC.

Address: 209 South Meldrum Street, Fort Collins, CO 80521

Issued By: Bureau Veritas Consumer Products Services (H.K.) Ltd., Taoyuan Branch
Lin Kou Laboratories

Lab Address: No. 47-2, 14th Ling, Chia Pau Vil., Lin Kou Dist., New Taipei City, Taiwan

Test Location: No. 19, Hwa Ya 2nd Rd., Wen Hwa Vil., Kwei Shan Dist., Taoyuan City
33383, TAIWAN

**FCC Registration /
Designation Number:** 788550 / TW0003



This report is for your exclusive use. Any copying or replication of this report to or for any other person or entity, or use of our name or trademark, is permitted only with our prior written permission. This report sets forth our findings solely with respect to the test samples identified herein. The results set forth in this report are not indicative or representative of the quality or characteristics of the lot from which a test sample was taken or any similar or identical product unless specifically and expressly noted. Our report includes all of the tests requested by you and the results thereof based upon the information that you provided to us. You have 60 days from date of issuance of this report to notify us of any material error or omission caused by our negligence, provided, however, that such notice shall be in writing and shall specifically address the issue you wish to raise. A failure to raise such issue within the prescribed time shall constitute your unqualified acceptance of the completeness of this report, the tests conducted and the correctness of the report contents. Unless specific mention, the uncertainty of measurement has been explicitly taken into account to declare the compliance or non-compliance to the specification.

Table of Contents

Release Control Record	3
1 Certificate of Conformity	4
2 Summary of Test Results	5
2.1 Measurement Uncertainty.....	5
2.2 Modification Record.....	5
3 General Information	6
3.1 General Description of EUT.....	6
3.2 Description of Test Modes.....	6
3.2.1 Test Mode Applicability and Tested Channel Detail.....	7
3.3 Description of Support Units.....	8
3.3.1 Configuration of System under Test.....	8
3.4 General Description of Applied Standards.....	8
4 Test Types and Results	9
4.1 Radiated Emission and Bandedge Measurement.....	9
4.1.1 Limits of Radiated Emission and Bandedge Measurement.....	9
4.1.2 Test Instruments.....	10
4.1.3 Test Procedures.....	11
4.1.4 Deviation from Test Standard.....	11
4.1.5 Test Set Up.....	12
4.1.6 EUT Operating Conditions.....	12
4.1.7 Test Results.....	13
4.2 Conducted Emission Measurement.....	23
4.2.1 Limits of Conducted Emission Measurement.....	23
4.2.2 Test Instruments.....	23
4.2.3 Test Procedures.....	24
4.2.4 Deviation from Test Standard.....	24
4.2.5 Test Setup.....	24
4.2.6 EUT Operating Conditions.....	24
4.2.7 Test Results.....	25
4.3 20dB Bandwidth Measurement.....	29
4.3.1 Test SetUp.....	29
4.3.2 Test Instruments.....	29
4.3.3 Test Procedure.....	29
4.3.4 Deviation from Test Standard.....	29
4.3.5 EUT Operating Conditions.....	29
4.3.6 Test Results.....	30
5 Pictures of Test Arrangements	31
Appendix – Information of the Testing Laboratories	32

Release Control Record

Issue No.	Description	Date Issued
RFAQOT-WTW-P21080808	Original release	Nov. 11, 2021

1 Certificate of Conformity

Product: Wireless Power Bank for MagSafe

Brand: OTTERBOX

Test Model: OBFTC-0090-A

Sample Status: Engineering sample

Applicant: Otter Products, LLC.

Test Date: Aug. 26 ~ Aug. 27, 2021

Standards: 47 CFR FCC Part 15, Subpart C (Section 15.209)
ANSI C63.10: 2013

The above equipment has been tested by **Bureau Veritas Consumer Products Services (H.K.) Ltd., Taoyuan Branch**, and found compliance with the requirement of the above standards. The test record, data evaluation & Equipment Under Test (EUT) configurations represented herein are true and accurate accounts of the measurements of the sample's RF characteristics under the conditions specified in this report.

Prepared by : Celine Chou , **Date:** Nov. 11, 2021
Celine Chou / Senior Specialist

Approved by : Jeremy Lin , **Date:** Nov. 11, 2021
Jeremy Lin / Project Engineer

2 Summary of Test Results

47 CFR FCC Part 15, Subpart C (Section 15.209)			
FCC Clause	Test Item	Result	Remarks
15.207	AC Power Conducted Emission	Pass	Meet the requirement of limit. Minimum passing margin is -10.07dB at 0.45107MHz.
15.209	Radiated Emission Test	Pass	Meet the requirement of limit. Minimum passing margin is -6.47dB at 36.791MHz

Note: Determining compliance based on the results of the compliance measurement, not taking into account measurement instrumentation uncertainty.

2.1 Measurement Uncertainty

Where relevant, the following measurement uncertainty levels have been estimated for tests performed on the EUT as specified in CISPR 16-4-2:

Measurement	Frequency	Expanded Uncertainty (k=2) (\pm)
Conducted Emissions at mains ports	150kHz ~ 30MHz	2.94 dB
Radiated Emissions up to 1 GHz	9kHz ~ 30MHz	2.44 dB
	30MHz ~ 200MHz	2.93 dB
	200MHz ~ 1000MHz	2.95 dB

2.2 Modification Record

There were no modifications required for compliance.

3 General Information

3.1 General Description of EUT

Product	Wireless Power Bank for MagSafe
Brand	OTTERBOX
Test Model	OBFTC-0090-A
Sample Status	Engineering sample
Power Supply Rating	5Vdc (adapter or host equipment) 3.8Vdc (battery)
Modulation Type	FSK
Operating Frequency	112-205kHz
Antenna Type	Coil antenna (The Antenna information is declared by manufacturer and for more detailed features description, please refer to the manufacturer's specifications, the laboratory shall not be held responsible)
Field Strength	-15.95dBuV/m
Accessory Device	Refer to Note as below
Data Cable Supplied	Refer to Note as below
Maximum Power Output for charging coil	7.5W

Note: The EUT contains following accessory devices.

Item	Brand	Model	Description
Battery	DONGGUAN GANFENG	496074	3.8Vdc, 3020mAh
USB type C to type C Cable	-	-	0.15m shielded USB type C to type C Cable

3.2 Description of Test Modes

1 Frequency tested to this EUT.

Test Frequency (kHz)
128

3.2.1 Test Mode Applicability and Tested Channel Detail

EUT configure mode	Applicable to			Description
	RE<1G	PLC	BW	
-	√	√	-	-

Where **RE<1G**: Radiated Emission below 1GHz **PLC**: Power Line Conducted Emission
BW: 20dB Bandwidth

Note: The EUT was powered by notebook or adapter. After pre-tested, powered by adapter was the worst case and chosen for final test.

Radiated Emission Test (Below 1GHz):

- Pre-Scan has been conducted to determine the worst-case mode from all possible combinations between available modulations, data rates and antenna ports (if EUT with antenna diversity architecture).
- Following channel(s) was (were) selected for the final test as listed below.

EUT Configure Mode	Available Channel	Tested Channel
-	1	1

Power Line Conducted Emission Test:

- Pre-Scan has been conducted to determine the worst-case mode from all possible combinations between available modulations, data rates and antenna ports (if EUT with antenna diversity architecture).
- Following channel(s) was (were) selected for the final test as listed below.

EUT Configure Mode	Available Channel	Tested Channel
-	1	1

20dB Bandwidth Test:

- Pre-Scan has been conducted to determine the worst-case mode from all possible combinations between available modulations, data rates and antenna ports (if EUT with antenna diversity architecture).
- Following channel(s) was (were) selected for the final test as listed below.

EUT Configure Mode	Available Channel	Tested Channel
-	1	1

Test Condition:

Applicable To	Environmental Conditions	Input Power	Tested by
RE<1G	23 deg. C, 66% RH	120Vac, 60Hz	Cookie Ku
PLC	23 deg. C, 66% RH	120Vac, 60Hz	Cookie Ku
BW	23 deg. C, 66% RH	120Vac, 60Hz	Cookie Ku

3.3 Description of Support Units

The EUT has been tested as an independent unit together with other necessary accessories or support units. The following support units or accessories were used to form a representative test configuration during the tests.

ID	Product	Brand	Model No.	Serial No.	FCC ID	Remarks
A.	iPhone	APPLE	A2215	C39ZC1YEN6YC	BCG-E3307A	-
B.	Adapter	ASUS	AD827M	NA	NA	-

3.3.1 Configuration of System under Test

Charging Mode:

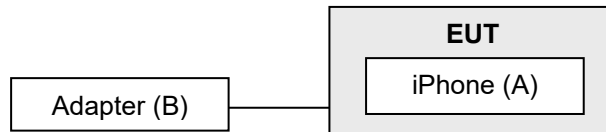

Standby Mode:

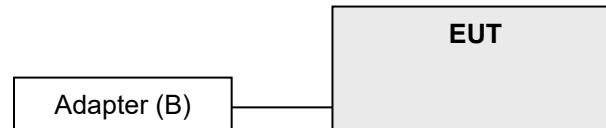

3.4 General Description of Applied Standards

The EUT is a RF Product. According to the specifications of the manufacturer, it must comply with the requirements of the following standards:

FCC Part 15, Subpart C (15.209)

ANSI C63.10-2013

All test items have been performed and recorded as per the above standards.

4 Test Types and Results

4.1 Radiated Emission and Bandedge Measurement

4.1.1 Limits of Radiated Emission and Bandedge Measurement

FOR FREQUENCY BELOW 30MHz

Frequency (MHz)	Field Strength (dBuV/m)		Measurement Distance (meters)
	uV/m	dBuV/m	
0.009 – 0.490	2400 / F (kHz)	48.52-13.80	300
0.490 – 1.705	24000 / F (kHz)	33.80-22.97	30
1.705 – 30.0	30	29.54	30

FOR FREQUENCY BETWEEN 30-1000MHz

Frequency (MHz)	Class A (at 10m)		Class B (at 3m)	
	uV/m	dBuV/m	uV/m	dBuV/m
30-88	90	39.1	100	40.0
88-216	150	43.5	150	43.5
216-960	210	46.4	200	46.0
Above 960	300	49.5	500	54.0

4.1.2 Test Instruments

Description & Manufacturer	Model No.	Serial No.	Cal. Date	Cal. Due
Spectrum Analyzer Agilent	N9010A	MY52220314	Dec. 07, 2020	Dec. 06, 2021
Spectrum Analyzer ROHDE & SCHWARZ	FSU43	101261	Apr. 12, 2021	Apr. 11, 2022
HORN Antenna SCHWARZBECK	BBHA 9120D	9120D-969	Nov. 22, 2020	Nov. 21, 2021
BILOG Antenna SCHWARZBECK	VULB 9168	9168-472	Nov. 06, 2020	Nov. 05, 2021
Fixed Attenuator WOKEN	MDCS18N-10	MDCS18N-10-01	Apr. 13, 2021	Apr. 12, 2022
Loop Antenna	EM-6879	269	Sep. 17, 2020	Sep. 16, 2021
Preamplifier EMCI	EMC001340	980201	Oct. 21, 2020	Oct. 20, 2021
Preamplifier EMCI	EMC 012645	980115	Oct. 07, 2020	Oct. 06, 2021
Preamplifier EMCI	EMC 330H	980112	Oct. 07, 2020	Oct. 06, 2021
Power Meter Anritsu	ML2495A	1012010	Sep. 01, 2020	Aug. 31, 2021
Power Sensor Anritsu	MA2411B	1315050	Sep. 01, 2020	Aug. 31, 2021
RF Coaxial Cable EMCI	EMC104-SM-SM-8000	171005	Oct. 07, 2020	Oct. 06, 2021
RF Coaxial Cable HUBER+SUHNNER	SUCOFLEX 104	EMC104-SM-SM-1000 (140807)	Oct. 07, 2020	Oct. 06, 2021
RF Coaxial Cable WOKEN	8D-FB	Cable-Ch10-01	Oct. 07, 2020	Oct. 06, 2021
Boresight Antenna Fixture	FBA-01	FBA-SIP01	NA	NA
Software BV ADT	E3 6.120103	NA	NA	NA
Antenna Tower MF	MFA-440H	NA	NA	NA
Turn Table MF	MFT-201SS	NA	NA	NA
Antenna Tower & Turn Table Controller MF	MF-7802	NA	NA	NA

Note: 1. The calibration interval of the above test instruments is 12 months and the calibrations are traceable to NML/ROC and NIST/USA.

2. The test was performed in HwaYa Chamber 10.

4.1.3 Test Procedures

For Radiated emission below 30MHz

- a. The EUT was placed on the top of a rotating table 0.8 meters above the ground at a 3 meter chamber room. The table was rotated 360 degrees to determine the position of the highest radiation.
- b. The EUT was set 3 meters away from the interference-receiving antenna, which was mounted on the top of a variable-height antenna tower.
- c. Parallel, perpendicular, and Ground-Parallel orientations of the antenna are set to make the measurement.
- d. For each suspected emission, the EUT was arranged to its worst case and the rotatable table was turned from 0 degrees to 360 degrees to find the maximum reading.
- e. The test-receiver system was set to Quasi-Peak Detect Function and Specified Bandwidth with Maximum Hold Mode, except for the frequency band (9kHz-90kHz, 110kHz-490kHz) set to average detect function and peak detect function.

Note:

1. The resolution bandwidth and video bandwidth of test receiver/spectrum analyzer is 9kHz at frequency below 30MHz.

For Radiated emission above 30MHz

- a. The EUT was placed on the top of a rotating table 0.8 meters (for below 1GHz) / 1.5 meters (for above 1GHz) above the ground at 3 meter chamber room for test. The table was rotated 360 degrees to determine the position of the highest radiation.
- b. The EUT was set 3 meters away from the interference-receiving antenna, which was mounted on the top of a variable-height antenna tower.
- c. The height of antenna is varied from one meter to four meters above the ground to determine the maximum value of the field strength. Both horizontal and vertical polarizations of the antenna are set to make the measurement.
- d. For each suspected emission, the EUT was arranged to its worst case and then the antenna was tuned to heights from 1 meter to 4 meters and the rotatable table was turned from 0 degrees to 360 degrees to find the maximum reading.
- e. The test-receiver system was set to quasi-peak detect function and specified bandwidth with maximum hold mode when the test frequency is below 1 GHz.
- f. The test-receiver system was set to peak and average detect function and specified bandwidth with maximum hold mode when the test frequency is above 1 GHz. If the peak reading value also meets average limit, measurement with the average detector is unnecessary.

Note:

1. The resolution bandwidth and video bandwidth of test receiver/spectrum analyzer is 120kHz for Quasi-peak detection (QP) at frequency below 1GHz.
2. All modes of operation were investigated and the worst-case emissions are reported.

4.1.4 Deviation from Test Standard

No deviation.

4.1.5 Test Set Up

For Radiated emission below 30MHz

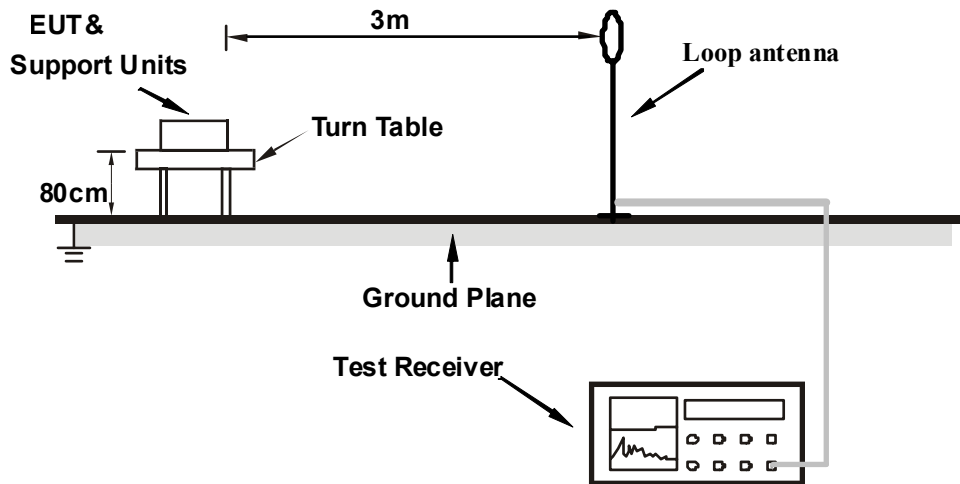

For Radiated emission 30MHz to 1GHz

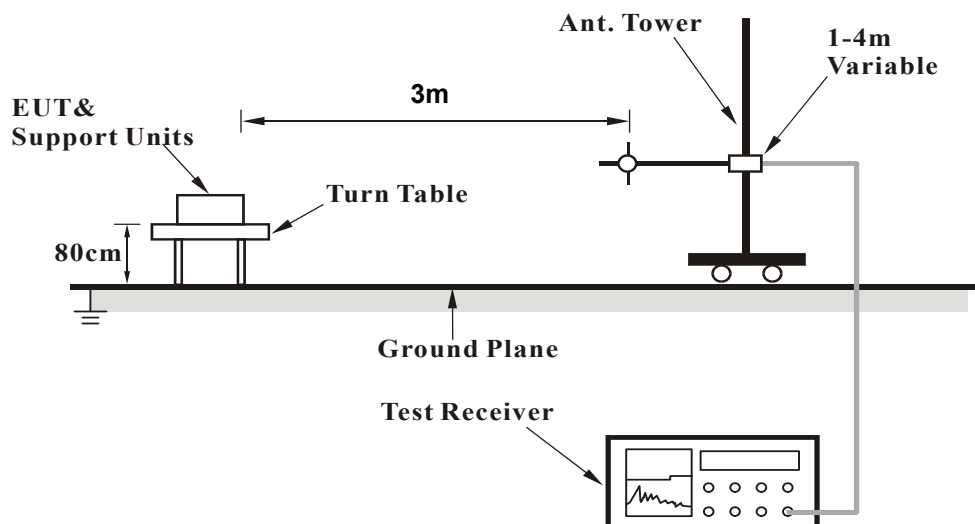

For the actual test configuration, please refer to the attached file (Test Setup Photo).

4.1.6 EUT Operating Conditions

Charging Mode:

- The EUT powered by adapter.
- Put the iPhone on the EUT (wireless charging) during the test.

Standby Mode:

- The EUT powered by adapter.

4.1.7 Test Results

Below 30MHz Data:

Charging Mode

Channel	TX Channel 1	Detector Function	Peak (PK)
Frequency Range	9 kHz ~ 30 MHz		Average (AV)

Antenna Polarity & Test Distance: Loop antenna Parallel at 3m								
No.	Freq. (MHz)	Emission Level (dBuV/m)	Limit (dBuV/m)	Margin (dB)	Antenna Height (m)	Table Angle (Degree)	Raw Value (dBuV)	Correction Factor (dB/m)
1	*0.128	-15.95 PK	45.46	-61.41	1.00	136	44.25	-60.20
2	*0.128	-16.07 AV	25.46	-41.53	1.00	136	44.13	-60.20
3	3.098	2.53 QP	29.54	-27.01	1.00	198	22.52	-19.99
4	6.187	9.35 QP	29.54	-20.19	1.00	94	28.75	-19.40
5	8.556	-0.72 QP	29.54	-30.26	1.00	256	17.87	-18.59
6	15.334	-1.04 QP	29.54	-30.58	1.00	79	16.90	-17.94
7	21.243	-0.43 QP	29.54	-29.97	1.00	231	17.39	-17.82
8	24.482	3.27 QP	29.54	-26.27	1.00	156	21.16	-17.89

Remarks:

1. Emission Level(dBuV/m) = Raw Value(dBuV) + Correction Factor(dB/m)
2. Correction Factor(dB/m) = Antenna Factor(dB/m) + Cable Factor(dB) – Pre-Amplifier Factor(dB)
3. The other emission levels were very low against the limit.
4. Margin value = Emission Level – Limit value
5. “ * “: Fundamental frequency.
6. Loop antenna was used for all radiated emission below 30MHz.
7. For 0.009 ~ 0.49MHz, the measured field strength was extrapolated to distance 300 meters
 Distance factor@3m = $40 \cdot \log(3/300) = -80\text{dB}$
 For 0.49 ~ 30MHz, the measured field strength was extrapolated to distance 30 meters
 Distance factor@3m = $40 \cdot \log(3/30) = -40\text{dB}$

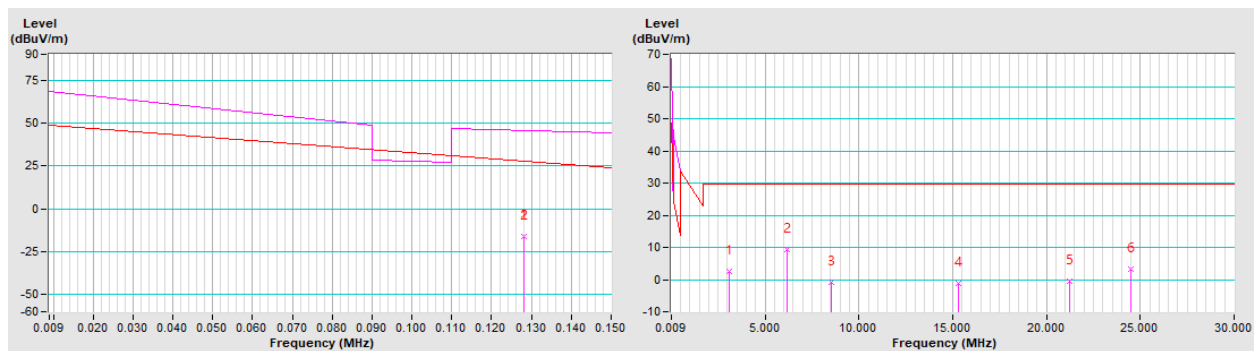

Channel	TX Channel 1	Detector Function	Peak (PK)
Frequency Range	9 kHz ~ 30 MHz		Average (AV)
			Quasi-Peak (QP)

Antenna Polarity & Test Distance: Loop antenna Perpendicular at 3m								
No.	Freq. (MHz)	Emission Level (dBuV/m)	Limit (dBuV/m)	Margin (dB)	Antenna Height (m)	Table Angle (Degree)	Raw Value (dBuV)	Correction Factor (dB/m)
1	*0.128	-20.97 PK	45.46	-66.43	1.00	56	39.23	-60.20
2	*0.128	-21.16 AV	25.46	-46.62	1.00	56	39.04	-60.20
3	3.278	-0.88 QP	29.54	-30.42	1.00	136	19.09	-19.97
4	8.496	-1.59 QP	29.54	-31.13	1.00	258	17.02	-18.61
5	12.635	-6.49 QP	29.54	-36.03	1.00	179	11.53	-18.02
6	16.954	-6.78 QP	29.54	-36.32	1.00	38	11.11	-17.89
7	21.932	-0.32 QP	29.54	-29.86	1.00	174	17.52	-17.84
8	24.752	1.61 QP	29.54	-27.93	1.00	327	19.51	-17.90

Remarks:

1. Emission Level(dBuV/m) = Raw Value(dBuV) + Correction Factor(dB/m)
2. Correction Factor(dB/m) = Antenna Factor(dB/m) + Cable Factor(dB) – Pre-Amplifier Factor(dB)
3. The other emission levels were very low against the limit.
4. Margin value = Emission Level – Limit value
5. “ * “: Fundamental frequency.
6. Loop antenna was used for all radiated emission below 30MHz.
7. For 0.009 ~ 0.49MHz, the measured field strength was extrapolated to distance 300 meters
 Distance factor@3m = $40 \cdot \log(3/300) = -80\text{dB}$
 For 0.49 ~ 30MHz, the measured field strength was extrapolated to distance 30 meters
 Distance factor@3m = $40 \cdot \log(3/30) = -40\text{dB}$

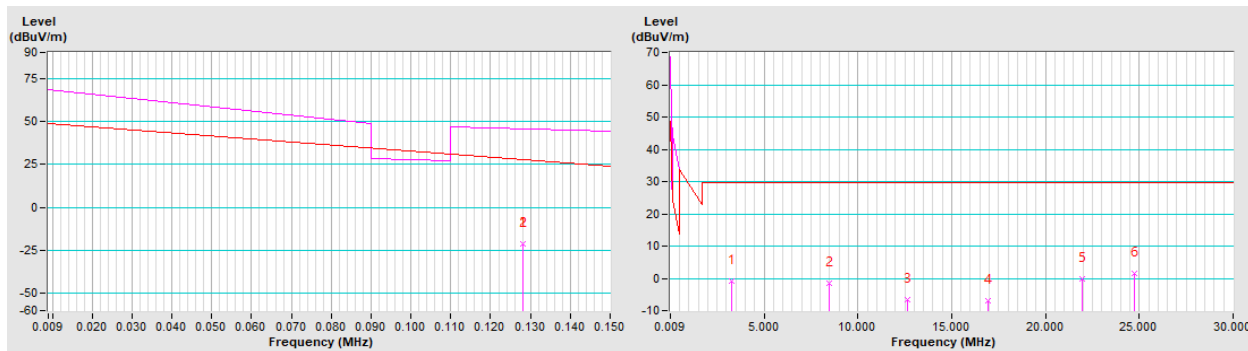

Channel	TX Channel 1	Detector Function	Peak (PK)
Frequency Range	9 kHz ~ 30 MHz		Average (AV)
			Quasi-Peak (QP)

Antenna Polarity & Test Distance: Loop antenna Ground-Parallel at 3m

No.	Freq. (MHz)	Emission Level (dBuV/m)	Limit (dBuV/m)	Margin (dB)	Antenna Height (m)	Table Angle (Degree)	Raw Value (dBuV)	Correction Factor (dB/m)
1	*0.128	-19.07 PK	45.46	-64.53	1.00	104	41.13	-60.20
2	*0.128	-19.28 AV	25.46	-44.74	1.00	104	40.92	-60.20
3	3.128	7.52 QP	29.54	-22.02	1.00	125	27.51	-19.99
4	8.556	3.61 QP	29.54	-25.93	1.00	183	22.20	-18.59
5	11.825	1.81 QP	29.54	-27.73	1.00	72	19.86	-18.05
6	17.494	-2.39 QP	29.54	-31.93	1.00	289	15.49	-17.88
7	21.722	-0.92 QP	29.54	-30.46	1.00	145	16.91	-17.83
8	24.482	-0.75 QP	29.54	-30.29	1.00	305	17.14	-17.89

Remarks:

1. Emission Level(dBuV/m) = Raw Value(dBuV) + Correction Factor(dB/m)
2. Correction Factor(dB/m) = Antenna Factor(dB/m) + Cable Factor(dB) – Pre-Amplifier Factor(dB)
3. The other emission levels were very low against the limit.
4. Margin value = Emission Level – Limit value
5. “ * “: Fundamental frequency.
6. Loop antenna was used for all radiated emission below 30MHz.
7. For 0.009 ~ 0.49MHz, the measured field strength was extrapolated to distance 300 meters
 Distance factor@3m = $40 \cdot \log(3/300) = -80\text{dB}$
 For 0.49 ~ 30MHz, the measured field strength was extrapolated to distance 30 meters
 Distance factor@3m = $40 \cdot \log(3/30) = -40\text{dB}$

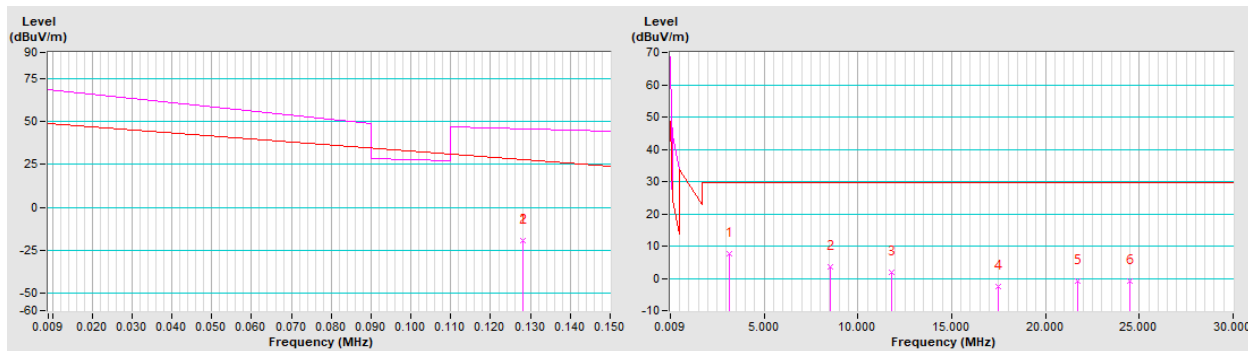

Standby Mode

Channel	TX Channel 1	Detector Function	Quasi-Peak (QP)
Frequency Range	9 kHz ~ 30 MHz		

Antenna Polarity & Test Distance: Loop antenna Parallel at 3m								
No.	Freq. (MHz)	Emission Level (dBuV/m)	Limit (dBuV/m)	Margin (dB)	Antenna Height (m)	Table Angle (Degree)	Raw Value (dBuV)	Correction Factor (dB/m)
1	4.358	4.09 QP	29.54	-25.45	1.00	242	23.95	-19.86
2	8.496	2.84 QP	29.54	-26.70	1.00	81	21.45	-18.61
3	11.825	3.50 QP	29.54	-26.04	1.00	296	21.55	-18.05
4	15.754	-2.62 QP	29.54	-32.16	1.00	110	15.31	-17.93
5	21.932	-1.65 QP	29.54	-31.19	1.00	318	16.19	-17.84
6	24.482	-0.69 QP	29.54	-30.23	1.00	182	17.20	-17.89

Remarks:

1. Emission Level(dBuV/m) = Raw Value(dBuV) + Correction Factor(dB/m)
2. Correction Factor(dB/m) = Antenna Factor(dB/m) + Cable Factor(dB) – Pre-Amplifier Factor(dB)
3. The other emission levels were very low against the limit.
4. Margin value = Emission Level – Limit value
5. “ * “: Fundamental frequency.
6. Loop antenna was used for all radiated emission below 30MHz.
7. For 0.49 ~ 30MHz, the measured field strength was extrapolated to distance 30 meters Distance factor@3m = $40 \cdot \log(3/30) = -40\text{dB}$

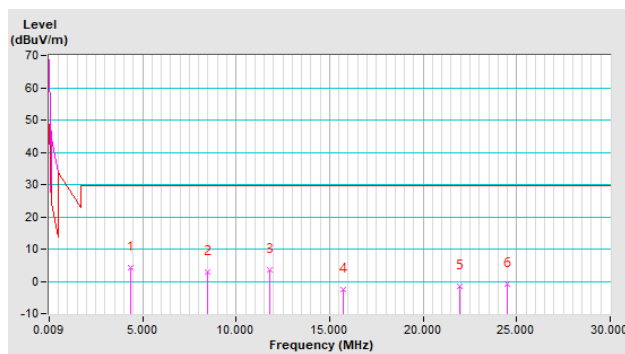

Channel	TX Channel 1	Detector Function	Quasi-Peak (QP)
Frequency Range	9 kHz ~ 30 MHz		

Antenna Polarity & Test Distance: Loop antenna Perpendicular at 3m								
No.	Freq. (MHz)	Emission Level (dBuV/m)	Limit (dBuV/m)	Margin (dB)	Antenna Height (m)	Table Angle (Degree)	Raw Value (dBuV)	Correction Factor (dB/m)
1	4.298	5.61 QP	29.54	-23.93	1.00	56	25.48	-19.87
2	8.496	6.69 QP	29.54	-22.85	1.00	194	25.30	-18.61
3	11.825	-3.02 QP	29.54	-32.56	1.00	128	15.03	-18.05
4	15.994	-3.65 QP	29.54	-33.19	1.00	76	14.27	-17.92
5	20.793	2.66 QP	29.54	-26.88	1.00	236	20.48	-17.82
6	24.482	5.34 QP	29.54	-24.20	1.00	131	23.23	-17.89

Remarks:

1. Emission Level(dBuV/m) = Raw Value(dBuV) + Correction Factor(dB/m)
2. Correction Factor(dB/m) = Antenna Factor(dB/m) + Cable Factor(dB) – Pre-Amplifier Factor(dB)
3. The other emission levels were very low against the limit.
4. Margin value = Emission Level – Limit value
5. “ * “: Fundamental frequency.
6. Loop antenna was used for all radiated emission below 30MHz.
7. For 0.49 ~ 30MHz, the measured field strength was extrapolated to distance 30 meters Distance factor@3m = $40 \cdot \log(3/30) = -40\text{dB}$

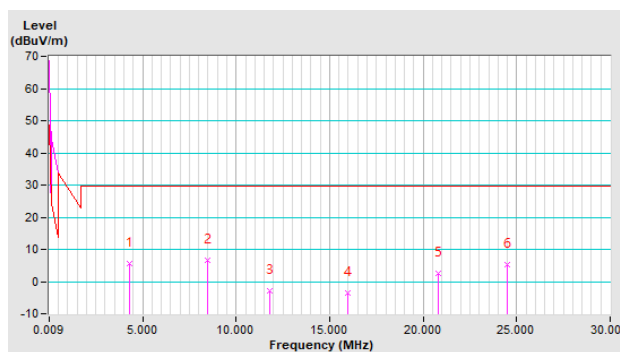

Channel	TX Channel 1	Detector Function	Quasi-Peak (QP)
Frequency Range	9 kHz ~ 30 MHz		

Antenna Polarity & Test Distance: Loop antenna Ground-Parallel at 3m								
No.	Freq. (MHz)	Emission Level (dBuV/m)	Limit (dBuV/m)	Margin (dB)	Antenna Height (m)	Table Angle (Degree)	Raw Value (dBuV)	Correction Factor (dB/m)
1	4.088	1.26 QP	29.54	-28.28	1.00	126	21.15	-19.89
2	7.117	5.96 QP	29.54	-23.58	1.00	189	25.04	-19.08
3	8.766	4.25 QP	29.54	-25.29	1.00	64	22.77	-18.52
4	13.565	-2.23 QP	29.54	-31.77	1.00	137	15.76	-17.99
5	21.483	-0.81 QP	29.54	-30.35	1.00	248	17.02	-17.83
6	24.482	2.79 QP	29.54	-26.75	1.00	49	20.68	-17.89

Remarks:

1. Emission Level(dBuV/m) = Raw Value(dBuV) + Correction Factor(dB/m)
2. Correction Factor(dB/m) = Antenna Factor(dB/m) + Cable Factor(dB) – Pre-Amplifier Factor(dB)
3. The other emission levels were very low against the limit.
4. Margin value = Emission Level – Limit value
5. “ * “: Fundamental frequency.
6. Loop antenna was used for all radiated emission below 30MHz.
7. For 0.49 ~ 30MHz, the measured field strength was extrapolated to distance 30 meters Distance factor@3m = $40 \cdot \log(3/30) = -40\text{dB}$

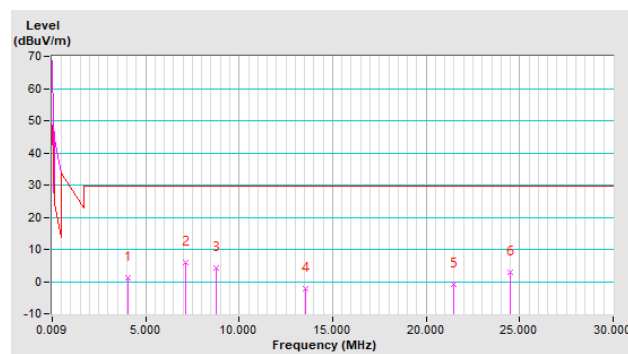

Below 1GHz Data:

Charging Mode

Channel	TX Channel 1	Detector Function	Quasi-Peak (QP)
Frequency Range	30MHz ~ 1GHz		

Antenna Polarity & Test Distance: Horizontal At 3m								
No.	Freq. (MHz)	Emission Level (dBuV/m)	Limit (dBuV/m)	Margin (dB)	Antenna Height (m)	Table Angle (Degree)	Raw Value (dBuV)	Correction Factor (dB/m)
1	58.133	32.70 QP	40.00	-7.30	1.27 H	245	45.88	-13.18
2	100.817	36.02 QP	43.50	-7.48	1.68 H	306	52.37	-16.35
3	283.196	29.76 QP	46.00	-16.24	1.97 H	285	41.92	-12.16
4	512.140	25.26 QP	46.00	-20.74	1.03 H	57	30.80	-5.54
5	701.309	29.28 QP	46.00	-16.72	2.31 H	148	30.80	-1.52
6	883.688	32.90 QP	46.00	-13.10	1.00 H	83	31.43	1.47

Remarks:

1. Emission Level(dBuV/m) = Raw Value(dBuV) + Correction Factor(dB/m)
2. Correction Factor(dB/m) = Antenna Factor(dB/m) + Cable Factor(dB) – Pre-Amplifier Factor(dB)
3. The other emission levels were very low against the limit.
4. Margin value = Emission Level – Limit value

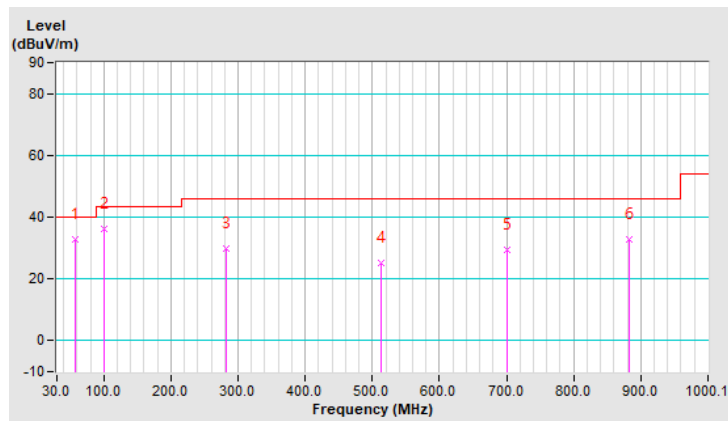

Channel	TX Channel 1	Detector Function	Quasi-Peak (QP)
Frequency Range	30MHz ~ 1GHz		

Antenna Polarity & Test Distance: Vertical At 3m								
No.	Freq. (MHz)	Emission Level (dBuV/m)	Limit (dBuV/m)	Margin (dB)	Antenna Height (m)	Table Angle (Degree)	Raw Value (dBuV)	Correction Factor (dB/m)
1	57.163	32.98 QP	40.00	-7.02	1.58 V	241	46.18	-13.20
2	118.279	32.91 QP	43.50	-10.59	1.31 V	249	46.90	-13.99
3	353.043	22.49 QP	46.00	-23.51	1.72 V	258	32.68	-10.19
4	553.854	27.86 QP	46.00	-18.14	2.20 V	93	32.39	-4.53
5	740.113	29.49 QP	46.00	-16.51	2.41 V	162	29.83	-0.34
6	930.253	32.27 QP	46.00	-13.73	1.07 V	256	29.70	2.57

Remarks:

1. Emission Level(dBuV/m) = Raw Value(dBuV) + Correction Factor(dB/m)
2. Correction Factor(dB/m) = Antenna Factor(dB/m) + Cable Factor(dB) – Pre-Amplifier Factor(dB)
3. The other emission levels were very low against the limit.
4. Margin value = Emission Level – Limit value

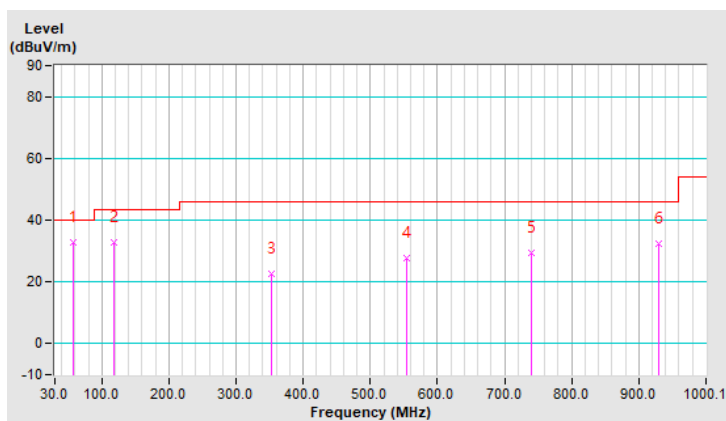

Standby Mode

Channel	TX Channel 1	Detector Function	Quasi-Peak (QP)
Frequency Range	30MHz ~ 1GHz		

Antenna Polarity & Test Distance: Horizontal At 3m								
No.	Freq. (MHz)	Emission Level (dBuV/m)	Limit (dBuV/m)	Margin (dB)	Antenna Height (m)	Table Angle (Degree)	Raw Value (dBuV)	Correction Factor (dB/m)
1	44.551	33.48 QP	40.00	-6.52	1.24 H	228	46.13	-12.65
2	205.588	23.34 QP	43.50	-20.16	1.53 H	146	39.41	-16.07
3	398.638	20.83 QP	46.00	-25.17	2.59 H	117	29.80	-8.97
4	587.808	26.49 QP	46.00	-19.51	1.06 H	231	29.95	-3.46
5	770.186	29.50 QP	46.00	-16.50	2.15 H	92	29.42	0.08
6	943.834	31.52 QP	46.00	-14.48	1.89 H	273	28.79	2.73

Remarks:

1. Emission Level(dBuV/m) = Raw Value(dBuV) + Correction Factor(dB/m)
2. Correction Factor(dB/m) = Antenna Factor(dB/m) + Cable Factor(dB) – Pre-Amplifier Factor(dB)
3. The other emission levels were very low against the limit.
4. Margin value = Emission Level – Limit value

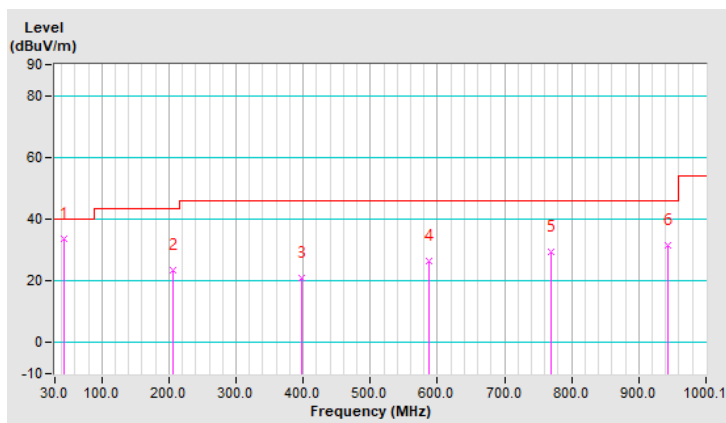

Channel	TX Channel 1	Detector Function	Quasi-Peak (QP)
Frequency Range	30MHz ~ 1GHz		

Antenna Polarity & Test Distance: Vertical At 3m								
No.	Freq. (MHz)	Emission Level (dBuV/m)	Limit (dBuV/m)	Margin (dB)	Antenna Height (m)	Table Angle (Degree)	Raw Value (dBuV)	Correction Factor (dB/m)
1	36.791	33.53 QP	40.00	-6.47	1.32 V	224	46.57	-13.04
2	205.588	25.53 QP	43.50	-17.97	1.56 V	207	41.60	-16.07
3	386.997	20.78 QP	46.00	-25.22	1.98 V	317	29.89	-9.11
4	558.705	25.54 QP	46.00	-20.46	1.29 V	62	29.92	-4.38
5	714.891	28.87 QP	46.00	-17.13	2.52 V	105	30.17	-1.30
6	869.136	32.57 QP	46.00	-13.43	1.18 V	102	31.24	1.33

Remarks:

1. Emission Level(dBuV/m) = Raw Value(dBuV) + Correction Factor(dB/m)
2. Correction Factor(dB/m) = Antenna Factor(dB/m) + Cable Factor(dB) – Pre-Amplifier Factor(dB)
3. The other emission levels were very low against the limit.
4. Margin value = Emission Level – Limit value

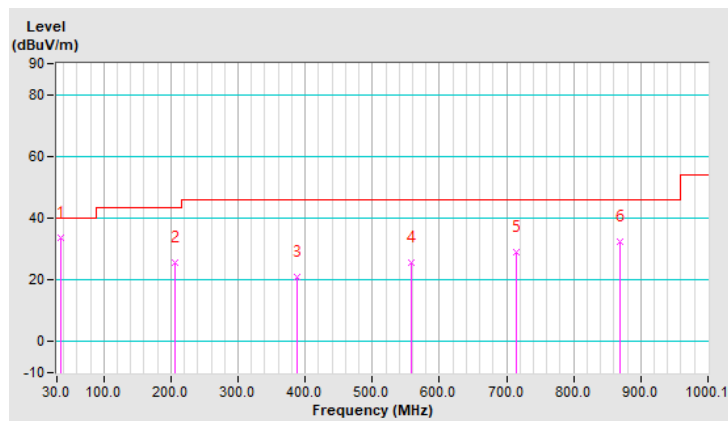

4.2 Conducted Emission Measurement

4.2.1 Limits of Conducted Emission Measurement

Frequency (MHz)	Conducted Limit (dBuV)	
	Quasi-peak	Average
0.15 - 0.5	66 - 56	56 - 46
0.50 - 5.0	56	46
5.0 - 30.0	60	50

Note: 1. The lower limit shall apply at the transition frequencies.

2. The limit decreases in line with the logarithm of the frequency in the range of 0.15 to 0.50MHz.

4.2.2 Test Instruments

Description & Manufacturer	Model No.	Serial No.	Cal. Date	Cal. Due
Test Receiver ROHDE & SCHWARZ	ESCI	100613	Dec. 04, 2020	Dec. 03, 2021
RF signal cable Woken	5D-FB	Cable-cond1-01	Jan. 16, 2021	Jan. 15, 2022
LISN ROHDE & SCHWARZ (EUT)	ENV216	101826	Feb. 25, 2021	Feb. 24, 2022
LISN ROHDE & SCHWARZ (Peripheral)	ESH3-Z5	100311	Aug. 28, 2020	Aug. 27, 2021
Software ADT	BV ADT_Cond_ V7.3.7.4	NA	NA	NA

Note: 1. The calibration interval of the above test instruments is 12 months and the calibrations are traceable to NML/ROC and NIST/USA.

2. The test was performed in HwaYa Shielded Room 1 (Conduction 1).

3. The VCCI Site Registration No. is C-12040.

4.2.3 Test Procedures

- The EUT was placed 0.4 meters from the conducting wall of the shielded room with EUT being connected to the power mains through a line impedance stabilization network (LISN). Other support units were connected to the power mains through another LISN. The two LISNs provide 50 ohm/ 50uH of coupling impedance for the measuring instrument.
- Both lines of the power mains connected to the EUT were checked for maximum conducted interference.
- The frequency range from 150kHz to 30MHz was searched. Emission levels under (Limit - 20dB) were not recorded.

NOTE: The resolution bandwidth and video bandwidth of test receiver is 9kHz for quasi-peak detection (QP) and average detection (AV) at frequency 0.15MHz-30MHz.

4.2.4 Deviation from Test Standard

No deviation.

4.2.5 Test Setup

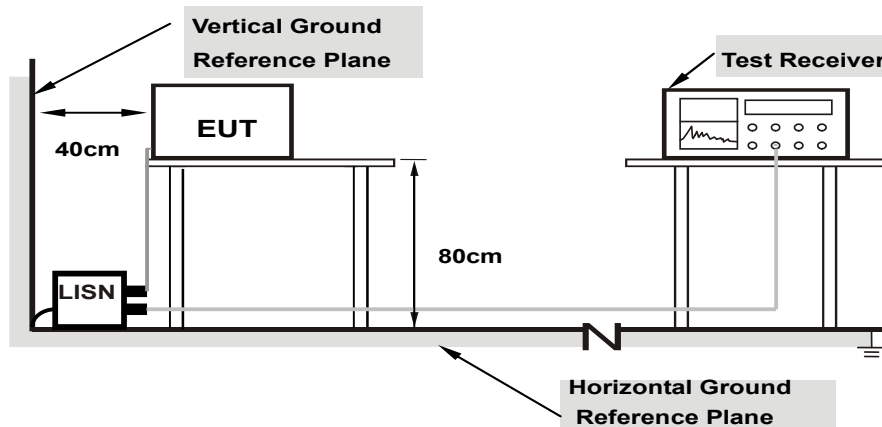

Note: 1.Support units were connected to second LISN.

For the actual test configuration, please refer to the attached file (Test Setup Photo).

4.2.6 EUT Operating Conditions

Same as 4.1.6.

4.2.7 Test Results

Charging Mode

Phase	Line (L)	Detector Function	Quasi-Peak (QP) / Average (AV)
-------	----------	-------------------	--------------------------------

No	Freq. [MHz]	Corr. Factor (dB)	Reading Value [dB (uV)]		Emission Level [dB (uV)]		Limit [dB (uV)]		Margin (dB)	
			Q.P.	AV.	Q.P.	AV.	Q.P.	AV.	Q.P.	AV.
			1	0.17346	9.76	41.15	21.37	50.91	31.13	64.79
2	0.36896	9.82	33.61	9.65	43.43	19.47	58.52	48.52	-15.09	-29.05
3	1.18224	9.92	29.14	1.87	39.06	11.79	56.00	46.00	-16.94	-34.21
4	3.66509	9.97	32.50	25.81	42.47	35.78	56.00	46.00	-13.53	-10.22
5	5.26819	10.00	24.02	21.85	34.02	31.85	60.00	50.00	-25.98	-18.15
6	19.92287	10.07	20.07	13.09	30.14	23.16	60.00	50.00	-29.86	-26.84

Remarks:

1. Q.P. and AV. are abbreviations of quasi-peak and average individually.
2. The emission levels of other frequencies were very low against the limit.
3. Margin value = Emission level - Limit value
4. Correction factor = Insertion loss + Cable loss
5. Emission Level = Correction Factor + Reading Value.

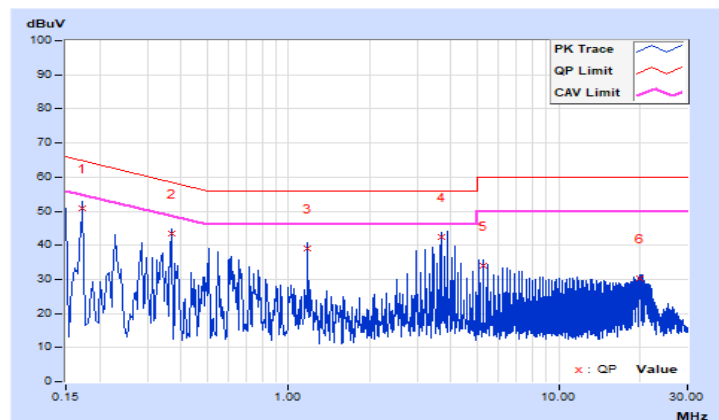

Phase	Neutral (N)	Detector Function	Quasi-Peak (QP) / Average (AV)
-------	-------------	-------------------	--------------------------------

No	Freq. [MHz]	Corr. Factor (dB)	Reading Value [dB (uV)]		Emission Level [dB (uV)]		Limit [dB (uV)]		Margin (dB)	
			Q.P.	AV.	Q.P.	AV.	Q.P.	AV.	Q.P.	AV.
			1	0.21256	9.83	35.14	6.67	44.97	16.50	63.10
2	0.32595	9.87	35.97	6.21	45.84	16.08	59.55	49.55	-13.71	-33.47
3	0.45107	9.91	36.88	7.34	46.79	17.25	56.86	46.86	-10.07	-29.61
4	3.66509	10.03	33.00	25.83	43.03	35.86	56.00	46.00	-12.97	-10.14
5	6.64451	10.08	18.85	17.22	28.93	27.30	60.00	50.00	-31.07	-22.70
6	20.38816	10.27	18.57	14.96	28.84	25.23	60.00	50.00	-31.16	-24.77

Remarks:

1. Q.P. and AV. are abbreviations of quasi-peak and average individually.
2. The emission levels of other frequencies were very low against the limit.
3. Margin value = Emission level - Limit value
4. Correction factor = Insertion loss + Cable loss
5. Emission Level = Correction Factor + Reading Value.

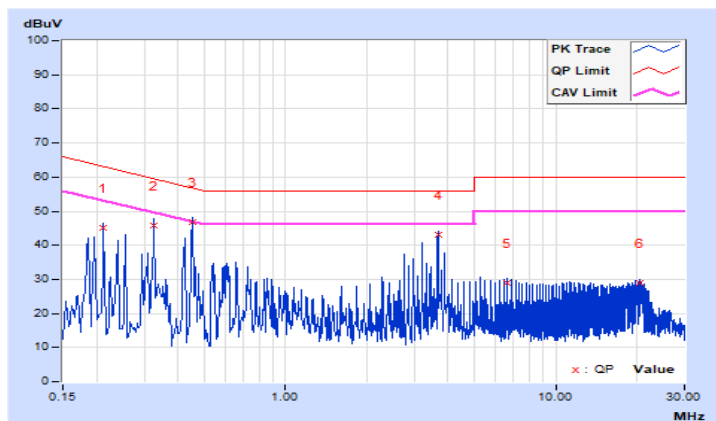

Standby Mode

Phase	Line (L)	Detector Function	Quasi-Peak (QP) / Average (AV)
-------	----------	-------------------	--------------------------------

No	Freq. [MHz]	Corr. Factor (dB)	Reading Value [dB (uV)]		Emission Level [dB (uV)]		Limit [dB (uV)]		Margin (dB)	
			Q.P.	AV.	Q.P.	AV.	Q.P.	AV.	Q.P.	AV.
			1	0.15000	9.75	19.51	10.30	29.26	20.05	66.00
2	0.72868	9.87	21.09	6.58	30.96	16.45	56.00	46.00	-25.04	-29.55
3	1.08058	9.91	24.81	2.30	34.72	12.21	56.00	46.00	-21.28	-33.79
4	3.37184	9.97	15.00	2.20	24.97	12.17	56.00	46.00	-31.03	-33.83
5	8.35709	10.04	12.49	2.45	22.53	12.49	60.00	50.00	-37.47	-37.51
6	13.56130	10.06	15.14	2.37	25.20	12.43	60.00	50.00	-34.80	-37.57

Remarks:

1. Q.P. and AV. are abbreviations of quasi-peak and average individually.
2. The emission levels of other frequencies were very low against the limit.
3. Margin value = Emission level - Limit value
4. Correction factor = Insertion loss + Cable loss
5. Emission Level = Correction Factor + Reading Value.

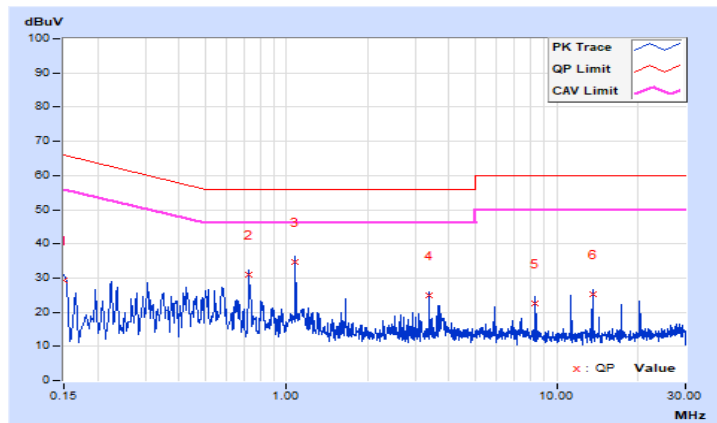

Phase		Neutral (N)			Detector Function		Quasi-Peak (QP) / Average (AV)			
No	Freq.	Corr. Factor	Reading Value		Emission Level		Limit		Margin	
	[MHz]		[dB]	[dB (uV)]	[dB (uV)]	[dB (uV)]	[dB (uV)]	[dB (uV)]	[dB (uV)]	[dB (uV)]
			Q.P.	AV.	Q.P.	AV.	Q.P.	AV.	Q.P.	AV.
1	0.18910	9.82	33.83	9.27	43.65	19.09	64.08	54.08	-20.43	-34.99
2	0.31422	9.87	28.65	8.73	38.52	18.60	59.86	49.86	-21.34	-31.26
3	0.73650	9.93	21.94	1.64	31.87	11.57	56.00	46.00	-24.13	-34.43
4	2.48818	10.00	12.03	1.10	22.03	11.10	56.00	46.00	-33.97	-34.90
5	4.98667	10.06	17.67	3.71	27.73	13.77	56.00	46.00	-28.27	-32.23
6	13.34625	10.18	14.35	1.38	24.53	11.56	60.00	50.00	-35.47	-38.44

Remarks:

1. Q.P. and AV. are abbreviations of quasi-peak and average individually.
2. The emission levels of other frequencies were very low against the limit.
3. Margin value = Emission level - Limit value
4. Correction factor = Insertion loss + Cable loss
5. Emission Level = Correction Factor + Reading Value.

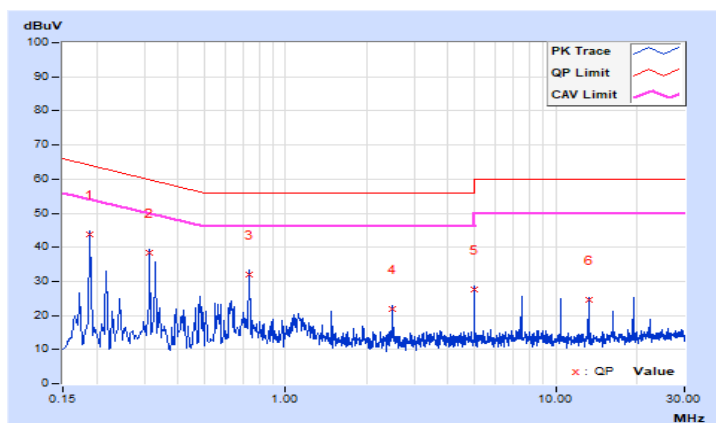

4.3 20dB Bandwidth Measurement

4.3.1 Test Setup

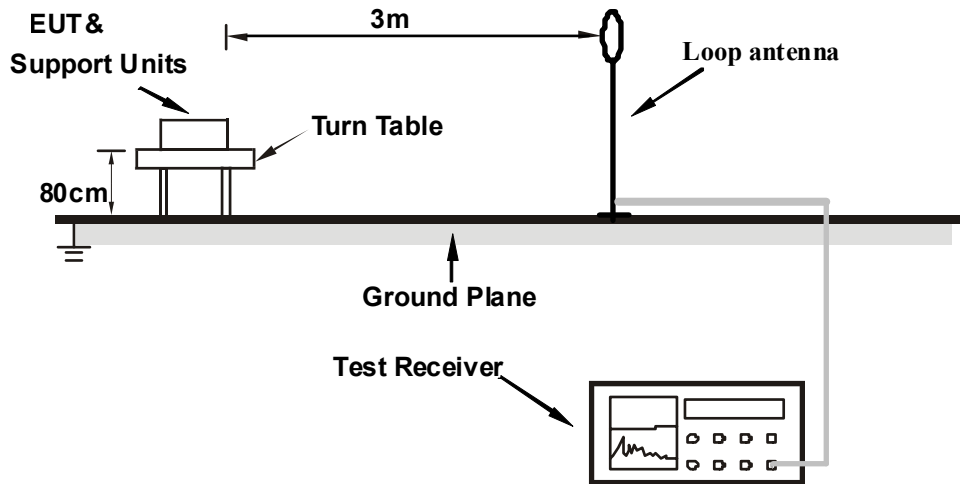

4.3.2 Test Instruments

Refer to section 4.1.2 to get information of above instrument.

4.3.3 Test Procedure

- The EUT was placed on the top of a rotating table 0.8 meters above the ground at a 3 meter Semi-anechoic chamber room. The table was rotated 360 degrees to determine the position of the highest radiation. Then the Loop antenna was rotated 360 degrees to determine the position of the highest radiation.
- The antenna is a broadband loop antenna, which is fixed of a 1m height above the ground, and set away from 3m to the EUT to find the disturbance reading on each frequency.
- The test-receiver system was set to Quasi-peak detect function and specified bandwidth.

4.3.4 Deviation from Test Standard

No deviation.

4.3.5 EUT Operating Conditions

The software provided by client to enable the EUT under transmission condition continuously.

4.3.6 Test Results

Frequency (kHz)	Occupied Bandwidth (kHz)	Pass / Fail
128	2.200	Pass



5 Pictures of Test Arrangements

Please refer to the attached file (Test Setup Photo).

Appendix – Information of the Testing Laboratories

We, Bureau Veritas Consumer Products Services (H.K.) Ltd., Taoyuan Branch, were founded in 1988 to provide our best service in EMC, Radio, Telecom and Safety consultation. Our laboratories are FCC recognized accredited test firms and accredited and approved according to ISO/IEC 17025.

If you have any comments, please feel free to contact us at the following:

Lin Kou EMC/RF Lab

Tel: 886-2-26052180

Fax: 886-2-26051924

Hsin Chu EMC/RF/Telecom Lab

Tel: 886-3-6668565

Fax: 886-3-6668323

Hwa Ya EMC/RF/Safety Lab

Tel: 886-3-3183232

Fax: 886-3-3270892

Email: service.adt@tw.bureauveritas.com

Web Site: www.bureauveritas-adt.com

The address and road map of all our labs can be found in our web site also.

--- END ---