



FCC RADIO TEST REPORT

FCC ID: 2AEDNA28

Product : 2.4GHz Wireless mouse
Trade Name : N/A
Model Name : SL-630010-BK
Serial Model : SL-630010-XX(XX stands for different product color)
Report No. : POCE-1605208202F

Prepared for

Winspeed Co., Ltd.

14 F-1, No. 2, Jian-Ba Rd., Chung-Ho District, New Taipei City, Taiwan

Prepared by

Shenzhen POCE Technology Co., Ltd.
Room 502, Bldg. 1, Xinghua Garden, Baoan Road Xixiang,
Baoan District, Shenzhen, China

VERIFICATION OF COMPLIANCE

Applicant's name : Winspeed Co., Ltd.
Address : 14 F-1, No.2, Jian-Ba Rd., Chung-Ho District, New Taipei City,
Taiwan

Manufacturer's Name : Winspeed Co., Ltd.
Address : 14 F-1, No.2, Jian-Ba Rd., Chung-Ho District, New Taipei City,
Taiwan

Product description

Product name : 2.4GHz Wireless mouse

Trademark: N/A

Test procedure FCC Part15.249

Standards ANSI C63.10: 2013

This device described above has been tested by POCE, and the test results show that the equipment under test (EUT) is in compliance with the FCC requirements. And it is applicable only to the tested sample identified in the report.

This report shall not be reproduced except in full, without the written approval of POCE, this document may be altered or revised by POCE, personal only, and shall be noted in the revision of the document.

Test Result..... : **Pass**

Date (s) of performance of tests : 1 May 2016 ~7 May 2016

Date of Issue..... : 7 May 2016

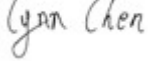
Testing Engineer : 
(Lynn Chen)

Technical Manager : 
(Carlen Liu)

Authorized Signatory : 
(Tommy zhang)

Table of Contents	Page
1 . SUMMARY OF TEST RESULTS	4
1.1 TEST FACILITY	5
1.2 MEASUREMENT UNCERTAINTY	5
2 . GENERAL INFORMATION	6
2.1 GENERAL DESCRIPTION OF EUT	6
2.2 DESCRIPTION OF TEST MODES	8
2.3 BLOCK DIGRAM SHOWING THE CONFIGURATION OF SYSTEM TESTED	9
2.4 DESCRIPTION OF SUPPORT UNITS(CONDUCTED MODE)	10
2.5 EQUIPMENTS LIST FOR ALL TEST ITEMS	11
3 . ANTENNA REQUIREMENT	12
3.1 STANDARD REQUIREMENT	12
3.2 EUT ANTENNA	12
3.3 CONDUCTED EMISSION MEASUREMENT	13
3.3.1 POWER LINE CONDUCTED EMISSION LIMITS	13
3.3.2 TEST PROCEDURE	14
3.3.3 DEVIATION FROM TEST STANDARD	14
3.3.4 TEST SETUP	14
3.2.5 TEST RESULT	15
3.4 RADIATED EMISSION MEASUREMENT	16
3.4.1 RADIATED EMISSION LIMITS	16
3.4.2 TEST PROCEDURE	17
3.4.3 DEVIATION FROM TEST STANDARD	17
3.4.4 TEST SETUP	18
3.4.5 TEST RESULTS (BLOW 30MHZ)	20
3.4.6 TEST RESULTS (BETWEEN 30 – 1000 MHZ)	21
3.4.7 TEST RESULTS (ABOVE 1000 MHZ)	27
3.4.8 TEST RESULTS (RESTRICTED BANDS REQUIREMENTS)	33
4 . BANDWIDTH TEST	37
4.1 TEST PROCEDURE	37
4.2 DEVIATION FROM STANDARD	37
4.3 TEST SETUP	37
4.4 TEST RESULTS	38
APPENDIX-PHOTOGRAPHS OF EUT CONSTRUCTIONAL DETAILS	

1. SUMMARY OF TEST RESULTS

Test procedures according to the technical standards:

FCC Part15, Subpart C (15.249)			
Standard Section	Test Item	Judgment	Remark
15.207	Conducted Emission	N/A	
15.203	Antenna Requirement	Pass	
15.249	Radiated Spurious Emission	Pass	
15.205	Band Edge Emission	Pass	
15.249	Occupied Bandwidth	Pass	

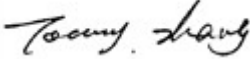
NOTE: (1) "N/A" denotes test is not applicable in this Test Report

1.1 TEST FACILITY

Shenzhen POCE Technology Co.,Ltd.

Add.: Room 502, Bldg. 1, Xinghua Garden, Baoan Road Xixiang, Baoan District, Shenzhen, China

FCC-Registration No.: 222278

1.2 MEASUREMENT UNCERTAINTY

The reported uncertainty of measurement $y \pm U$, where expanded uncertainty U is based on a standard uncertainty multiplied by a coverage factor of $k=2$, providing a level of confidence of approximately **95 %**.

No.	Item	Uncertainty
1	Conducted Emission Test	$\pm 1.38\text{dB}$
2	RF power,conducted	$\pm 0.16\text{dB}$
3	Spurious emissions,conducted	$\pm 0.21\text{dB}$
4	All emissions,radiated(<1G)	$\pm 4.68\text{dB}$
5	All emissions,radiated(>1G)	$\pm 4.89\text{dB}$
6	Temperature	$\pm 0.5^{\circ}\text{C}$
7	Humidity	$\pm 2\%$

2. GENERAL INFORMATION

2.1 GENERAL DESCRIPTION OF EUT

Equipment	2.4G Wireless Mouse	
Trade Name	N/A	
Model Name	SL-630010-BK	
Serial Model	SL-630010-XX(XX stands for different product color)	
Model Difference	All the same,only model name is different.	
Product Description	The EUT is a 2.4G Wireless Mouse	
	Operation Frequency:	2405~2470MHz
	Modulation Type:	GFSK
	Antenna Designation:	PCB Antenna
	Antenna Gain(Peak)	0 dBi
	EIRP	80.4dbuv/m@3m(Peak)
	Based on the application, features, or specification exhibited in User's Manual, the EUT is considered as an ITE/Computing Device. More details of EUT technical specification, please refer to the User's Manual.	
Rating	DC 3.0V	
Channel List	Please refer to the Note 2.	
Adapter	N/A	
Battery	1.5V*2cell "AA" alkaline battery	

Note:

1. For a more detailed features description, please refer to the manufacturer's specifications or the User's Manual.

2.

Channel List					
Channel	Frequency (MHz)	Channel	Frequency (MHz)	Channel	Frequency (MHz)
01	2405	28	2432	55	2459
02	2406	29	2433	56	2460
03	2407	30	2434	57	2461
04	2408	31	2435	58	2462
05	2409	32	2436	59	2463
06	2410	33	2437	60	2464
07	2411	34	2438	61	2465
08	2412	35	2439	62	2466
09	2413	36	2440	63	2467
10	2414	37	2441	64	2468
11	2415	38	2442	65	2469
12	2416	39	2443	66	2470
13	2417	40	2444	--	--
14	2418	41	2445		
15	2419	42	2446		
16	2420	43	2447		
17	2421	44	2448		
18	2422	45	2449		
19	2423	46	2450		
20	2424	47	2451		
21	2425	48	2452		
22	2426	49	2453		
23	2427	50	2454		
24	2428	51	2455		
25	2429	52	2456		
26	2430	53	2457		
27	2431	54	2458		

3.

Table for Filed Antenna

Ant	Brand	Model Name	Antenna Type	Connector	Gain (dBi)	NOTE
1	N/A	N/A	PCB Antenna	NA	0	Antenna

2.2 DESCRIPTION OF TEST MODES

To investigate the maximum EMI emission characteristics generates from EUT, the test system was pre-scanning tested base on the consideration of following EUT operation mode or test configuration mode which possible have effect on EMI emission level. Each of these EUT operation mode(s) or test configuration mode(s) mentioned above was evaluated respectively.

Pretest Mode	Description
Mode 1	CH01(2405MHz)
Mode 2	CH33(2437MHz)
Mode 3	CH66(2470MHz)

For Conducted Emission	
Final Test Mode	Description
N/A	N/A

For Radiated Emission	
Final Test Mode	Description
Mode 1	CH01(2405MHz)
Mode 2	CH33(2437MHz)
Mode 3	CH66(2470MHz)

Note:

- (1) The measurements are performed at the highest, middle, lowest available channels. The worst data will reported.
- (2) The EUT use new battery.

2.3 BLOCK DIGRAM SHOWING THE CONFIGURATION OF SYSTEM TESTED

Radiated Spurious Emission Test

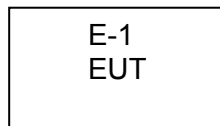

2.4 DESCRIPTION OF SUPPORT UNITS(CONDUCTED MODE)

The EUT has been tested as an independent unit together with other necessary accessories or support units. The following support units or accessories were used to form a representative test configuration during the tests.

Item	Equipment	Mfr/Brand	Model/Type No.	Series No.	Note
E-1	Wireless Mouse	N/A	SL-630010-BK	N/A	EUT

Item	Shielded Type	Ferrite Core	Length	Note

Note:

- (1) The support equipment was authorized by Declaration of Confirmation.
- (2) For detachable type I/O cable should be specified the length in cm in 『Length』 column.

2.5 EQUIPMENTS LIST FOR ALL TEST ITEMS

Radiation Test equipment

Item	Kind of Equipment	Manufacturer	Type No.	Serial No.	Last calibration	Calibrated until
1	EMI Test Receiver	R&S	ESU8	100316	2015/10/25	2016/10/24
2	Double Ridged Horn Antenna (0.8GHz-18GHz)	R&S	HF907	100276	2015/11/01	2016/10/31
3	Log-periodic Dipole Antenna (30MHz-1GHz)	R&S	HL223	100435	2015/11/01	2016/10/31
4	Biconical Antenna (9K-30MHz)	R&S	HK116	100431	2015/10/25	2016/10/24
5	Pre-amplifier	Schwarzbeck	VULB 9163	9163-462	2016/04/12	2017/04/11
6	Signal Conditioning Unit	R&S	SCU-08	10008	2015/10/25	2016/10/24
7	Rod Antenna (9K-30MHz)	R&S	HFH2-Z6	100386	2015/11/01	2016/10/31
8	Pre-amplifier	R&S	SCU-01	10049	2015/10/25	2016/10/24
9	Active loop antenna (9K-30MHz)	Schwarzbeck	FMZB1519	1519-038	2015/11/01	2016/10/31
10	Spectrum Analyzer	Agilent	E4407B	MY45109572	2015/11/01	2016/10/31

Conduction Test equipment

Item	Kind of Equipment	Manufacturer	Type No.	Serial No.	Last calibration	Calibrated until
1	Test Receiver	R&S	ESU8	100316	2015/10/25	2016/10/24
	Current Probe	R&S	EZ-17	100532	2015/10/25	2016/10/24
3	Two Line V-Network	R&S	ENV216	101109	2015/10/25	2016/10/24
4	Passive Voltage Probe	R&S	ESH2-Z3	100169	2015/10/25	2016/10/24
5	V-Network	R&S	ESH3-Z6	100694	2015/10/25	2016/10/24
6	V-Network	R&S	ESH3-Z6	100690	2015/10/25	2016/10/24
7	Artificial mains	R&S	ESH2-Z5	100309	2015/10/25	2016/10/24
8	Pulse Limiter	R&S	ESH3-Z2	101242	2015/10/25	2016/10/24

3. ANTENNA REQUIREMENT

3.1 STANDARD REQUIREMENT

15.203 requirement: For intentional device, according to 15.203: an intentional radiator shall be designed to ensure that no antenna other than that furnished by the responsible party shall be used with the device.

3.2 EUT ANTENNA

The EUT antenna is PCB Antenna. It comply with the standard requirement.

3.3 CONDUCTED EMISSION MEASUREMENT

3.3.1 POWER LINE CONDUCTED EMISSION Limits (Frequency Range 150KHz-30MHz)

FREQUENCY (MHz)	Class A (dBuV)		Class B (dBuV)		Standard
	Quasi-peak	Average	Quasi-peak	Average	
0.15 -0.5			66 - 56 *	56 - 46 *	CISPR
0.50 -5.0			56.00	46.00	CISPR
5.0 -30.0			60.00	50.00	CISPR

0.15 -0.5			66 - 56 *	56 - 46 *	LP002.
0.50 -5.0			56.00	46.00	LP002.
5.0 -30.0			60.00	50.00	LP002.

Note:

- (1) The tighter limit applies at the band edges.
- (2) The limit of " * " marked band means the limitation decreases linearly with the logarithm of the frequency in the range.

The following table is the setting of the receiver

Receiver Parameters	Setting
Attenuation	10 dB
Start Frequency	0.15 MHz
Stop Frequency	30 MHz
IF Bandwidth	9 kHz

3.3.2 TEST PROCEDURE

- a. The EUT was placed 0.4 meters from the horizontal ground plane with EUT being connected to the power mains through a line impedance stabilization network (LISN). All other support equipments powered from additional LISN(s). The LISN provide 50 Ohm/ 50uH of coupling impedance for the measuring instrument.
- b. Interconnecting cables that hang closer than 40 cm to the ground plane shall be folded back and forth in the center forming a bundle 30 to 40 cm long.
- c. I/O cables that are not connected to a peripheral shall be bundled in the center. The end of the cable may be terminated, if required, using the correct terminating impedance. The overall length shall not exceed 1 m.
- d. LISN at least 80 cm from nearest part of EUT chassis.
- e. For the actual test configuration, please refer to the related Item –EUT Test Photos.

3.3.3 DEVIATION FROM TEST STANDARD

No deviation

3.3.4 TEST SETUP

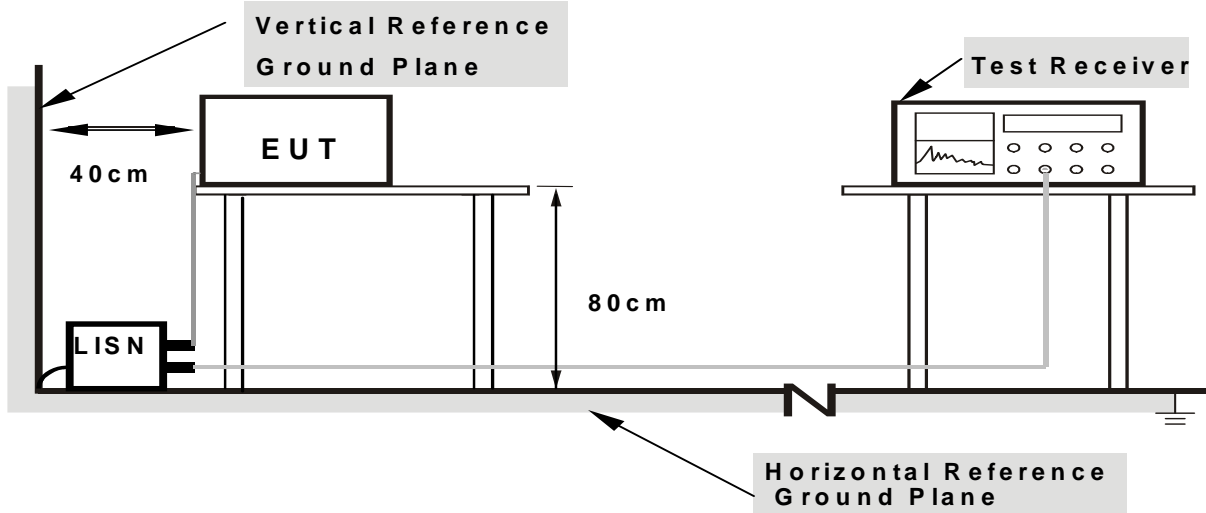

- Note:**
- 1. Support units were connected to second LISN.
 - 2. Both of LISNs (AMN) are 80 cm from EUT and at least 80 cm from other units and other metal planes

3.2.5 TEST RESULT

EUT :	Wireless Mouse	Model Name. :	SL-630010-BK
Temperature :	26 °C	Relative Humidity :	54%
Pressure :	1010hPa	Phase :	L
Test Voltage :	N/A	Test Mode :	N/A

NOTE: To Conducted Emission, not suitable for battery devices.

3.4 RADIATED EMISSION MEASUREMENT

3.4.1 Radiated Emission Limits (FCC 15.209)

Frequencies (MHz)	Field Strength (micorvolts/meter)	Measurement Distance (meters)
0.009~0.490	2400/F(KHz)	300
0.490~1.705	24000/F(KHz)	30
1.705~30.0	30	30
30~88	100	3
88~216	150	3
216~960	200	3
Above 960	500	3

Note:

- (1) The tighter limit applies at the band edges.
- (2) Emission level (dBuV/m)=20log Emission level (uV/m).

LIMITS OF RADIATED EMISSION MEASUREMENT (FCC 15.249)

Frequency of Emission (MHz)	Field Strength of fundamental ((millivolts /meter)	Field Strength of Harmonics (microvolts/meter)
2400 - 2483.5	50	500

Notes:

- (1) Emissions radiated outside of the specified frequency bands, except for harmonics, shall be attenuated by at least 50 dB below the level of the fundamental or to the general radiated emission limits in Section 15.209, whichever is the lesser attenuation.

Spectrum Parameter	Setting
Attenuation	Auto
Start Frequency	1000 MHz
Stop Frequency	10th carrier harmonic
RB / VB (emission in restricted band)	1MHz / 1MHz for Peak

Receiver Parameter	Setting
Attenuation	Auto
Start ~ Stop Frequency	9kHz~150kHz / RB 200Hz for QP
Start ~ Stop Frequency	150kHz~30MHz / RB 9kHz for QP
Start ~ Stop Frequency	30MHz~1000MHz / RB 120kHz for QP

3.4.2 TEST PROCEDURE

- a. The measuring distance of at 3 m shall be used for measurements at frequency up to 1GHz. For frequencies above 1GHz, any suitable measuring distance may be used.
- b. The EUT was placed on the top of a rotating table 0.8 meters above the ground at a 3m meter open area test site. The table was rotated 360 degrees to determine the position of the highest radiation.
- c. The height of the equipment or of the substitution antenna shall be 0.8 m; the height of the test antenna shall vary between 1 m to 4 m.
- d. The initial step in collecting conducted emission data is a spectrum analyzer peak detector mode pre-scanning the measurement frequency range. Significant peaks are then marked and then Quasi Peak detector mode re-measured.
- e. If the Peak Mode measured value compliance with and lower than Quasi Peak Mode Limit, the EUT shall be deemed to meet QP Limits and then no additional QP Mode measurement performed.
- f. For the actual test configuration, please refer to the related Item –EUT Test Photos.

Note:

Both horizontal and vertical antenna polarities were tested and performed pretest to three orthogonal axis. The worst case emissions were reported

3.4.3 DEVIATION FROM TEST STANDARD

No deviation

3.4.4 TEST SETUP

(A) Radiated Emission Test-Up Frequency Below 30MHz

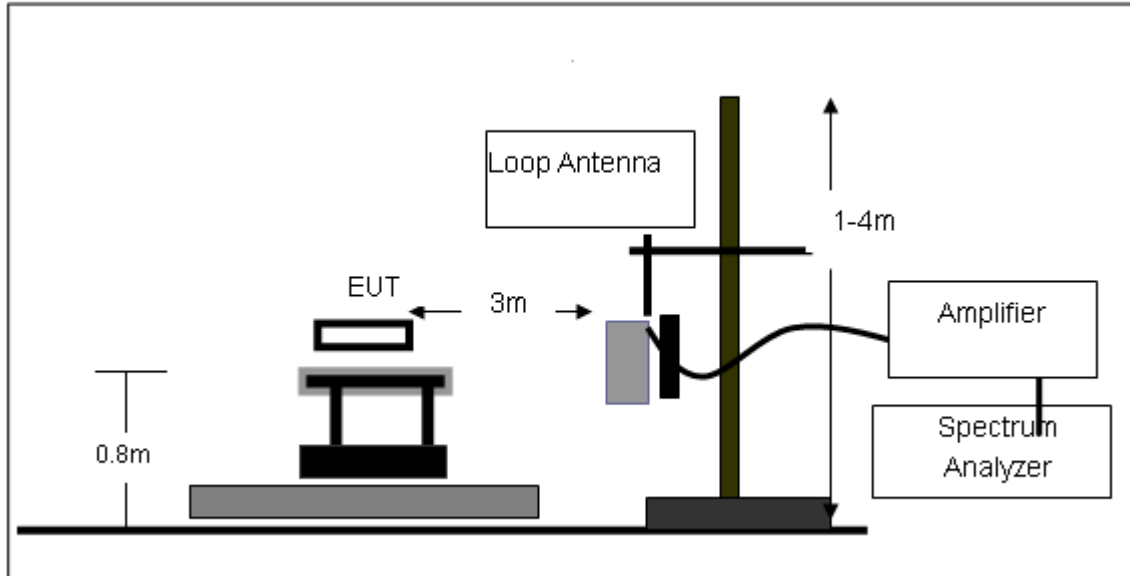

(B) Radiated Emission Test-Up Frequency 30MHz~1GHz

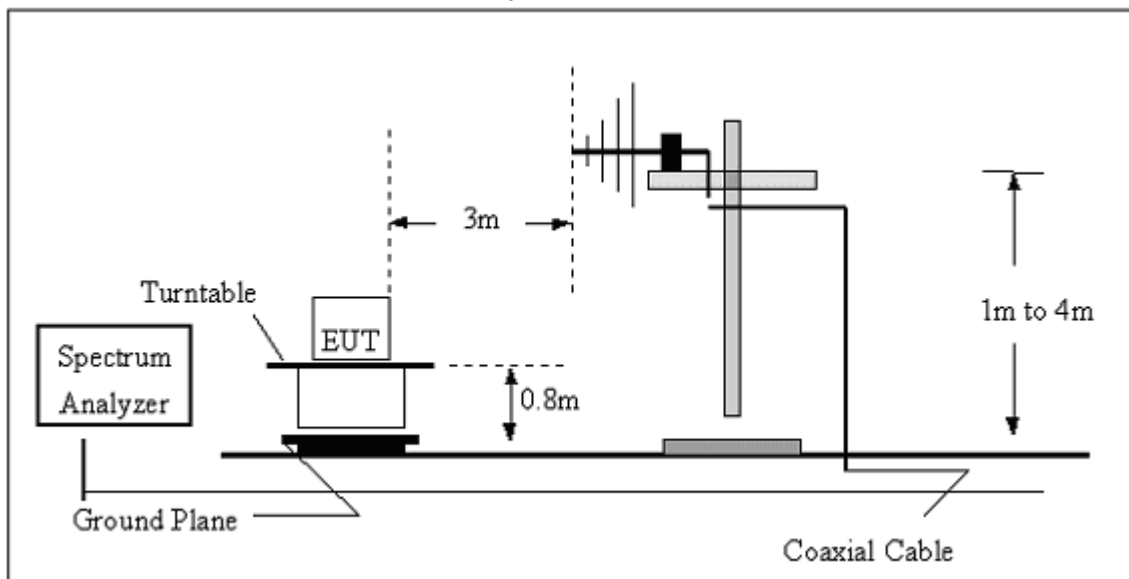

(C) Radiated Emission Test-Up Frequency Above 1GHz

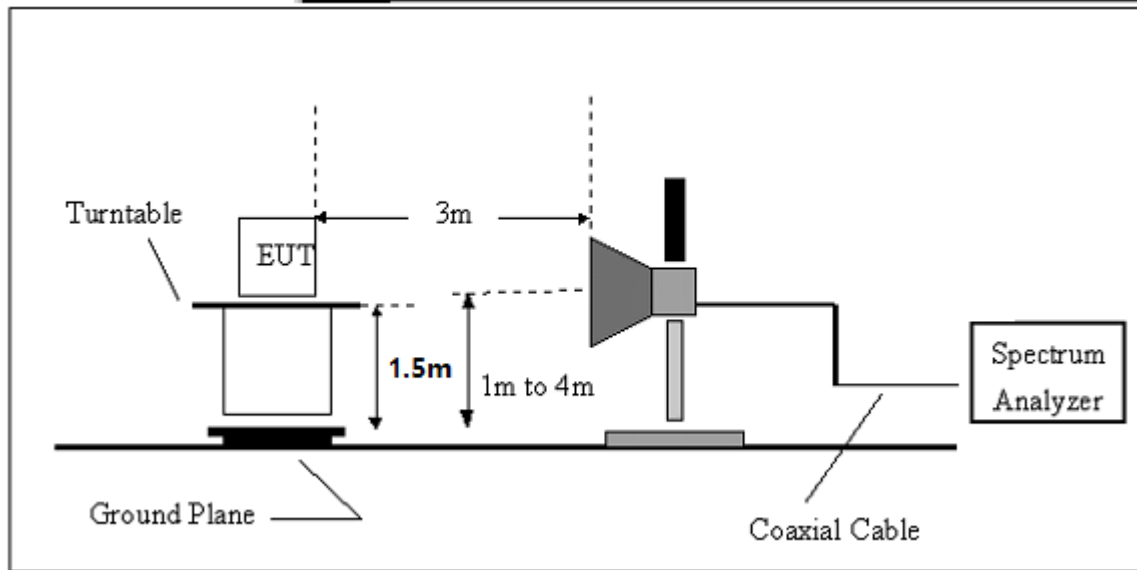

3.4.5 TEST RESULTS (BLOW 30MHz)

EUT :	Wireless Mouse	Model Name. :	SL-630010-BK
Temperature :	20 °C	Relative Humidity :	48%
Pressure :	1010 hPa	Test Voltage :	DC 3.0V
Test Mode :	TX	Polarization :	--

Freq.	Reading	Limit	Margin	State
(MHz)	(dBuV/m)	(dBuV/m)	(dB)	P/F
--	--	--	--	PASS
--	--	--	--	PASS

NOTE:

The amplitude of spurious emissions which are attenuated by more than 20dB below the permissible value has no need to be reported.

Distance extrapolation factor = $40 \log (\text{specific distance}/\text{test distance})$ (dB);

Limit line = specific limits(dBuv) + distance extrapolation factor.

3.4.6 TEST RESULTS (BETWEEN 30 – 1000 MHZ)

EUT :	Wireless Mouse	Model Name :	SL-630010-BK
Temperature :	20 °C	Relative Humidity :	48%
Pressure :	1010 hPa	Test Voltage :	DC 3.0V
Test Mode :	TX 2405MHz	Polarization :	Vertical

Frequency (MHz)	Meter Reading (dBµV)	Factor (dB)	Emission Level (dBµV/m)	Limits (dBµV/m)	Margin (dB)	Detector Type
52.9453	14.96	6.84	21.8	40	-18.2	QP
127.2176	10.46	11.91	22.37	43.5	-21.13	QP
549.0193	5.87	21.83	27.7	46	-18.3	QP

Remark:

1. Factor = Antenna Factor + Cable Loss – Pre-amplifier.

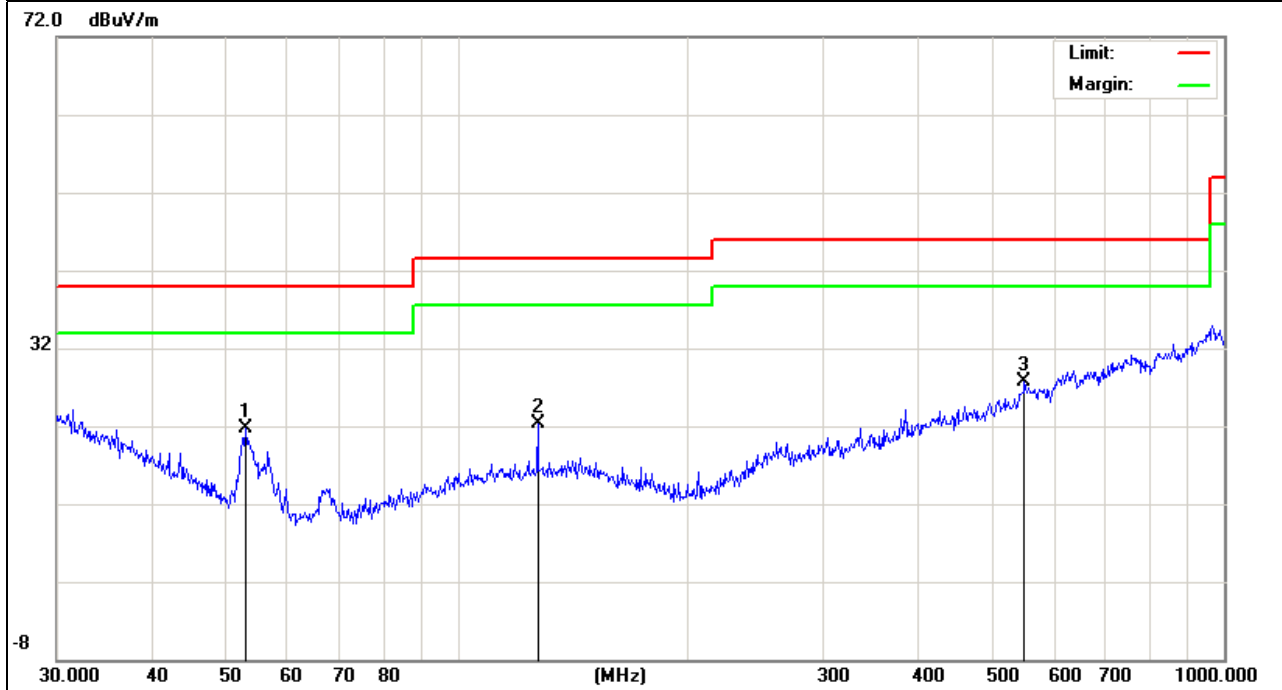

EUT :	Wireless Mouse	Model Name :	SL-630010-BK
Temperature :	20 °C	Relative Humidity :	48%
Pressure :	1010 hPa	Test Voltage :	DC 3.0V
Test Mode :	TX 2405MHz	Polarization :	Horizontal

Frequency (MHz)	Meter Reading (dBµV)	Factor (dB)	Emission Level (dBµV/m)	Limits (dBµV/m)	Margin (dB)	Detector Type
53.1313	21.28	6.76	28.04	40	-11.96	QP
126.3285	8.76	11.9	20.66	43.5	-22.84	QP
550.9479	5.93	21.92	27.85	46	-18.15	QP

Remark:

1. Factor = Antenna Factor + Cable Loss – Pre-amplifier.

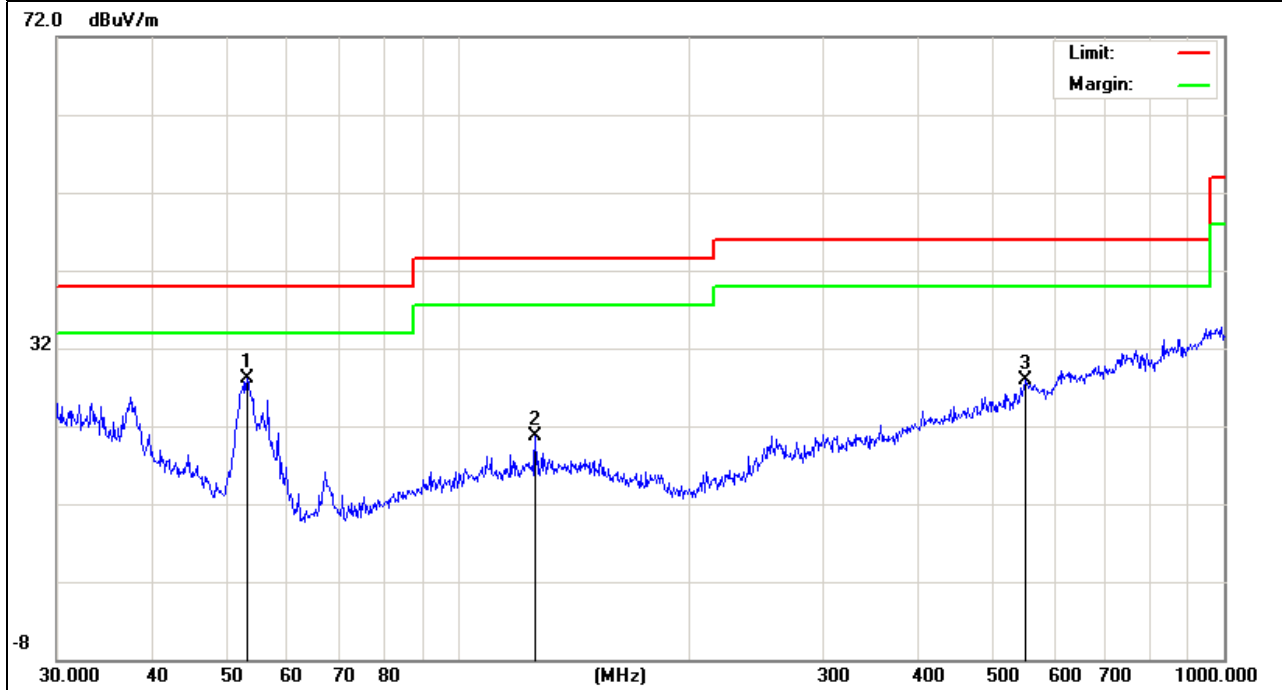

EUT :	Wireless Mouse	Model Name :	SL-630010-BK
Temperature :	20 °C	Relative Humidity :	48%
Pressure :	1010 hPa	Test Voltage :	DC 3.0V
Test Mode :	TX 2437MHz	Polarization :	Vertical

Frequency (MHz)	Meter Reading (dBµV)	Factor (dB)	Emission Level (dBµV/m)	Limits (dBµV/m)	Margin (dB)	Detector Type
52.7599	21.82	6.92	28.74	40	-11.26	QP
134.5592	5.45	11.98	17.43	43.5	-26.07	QP
568.6127	6.36	20.99	27.35	46	-18.65	QP

Remark:

1. Factor = Antenna Factor + Cable Loss – Pre-amplifier.

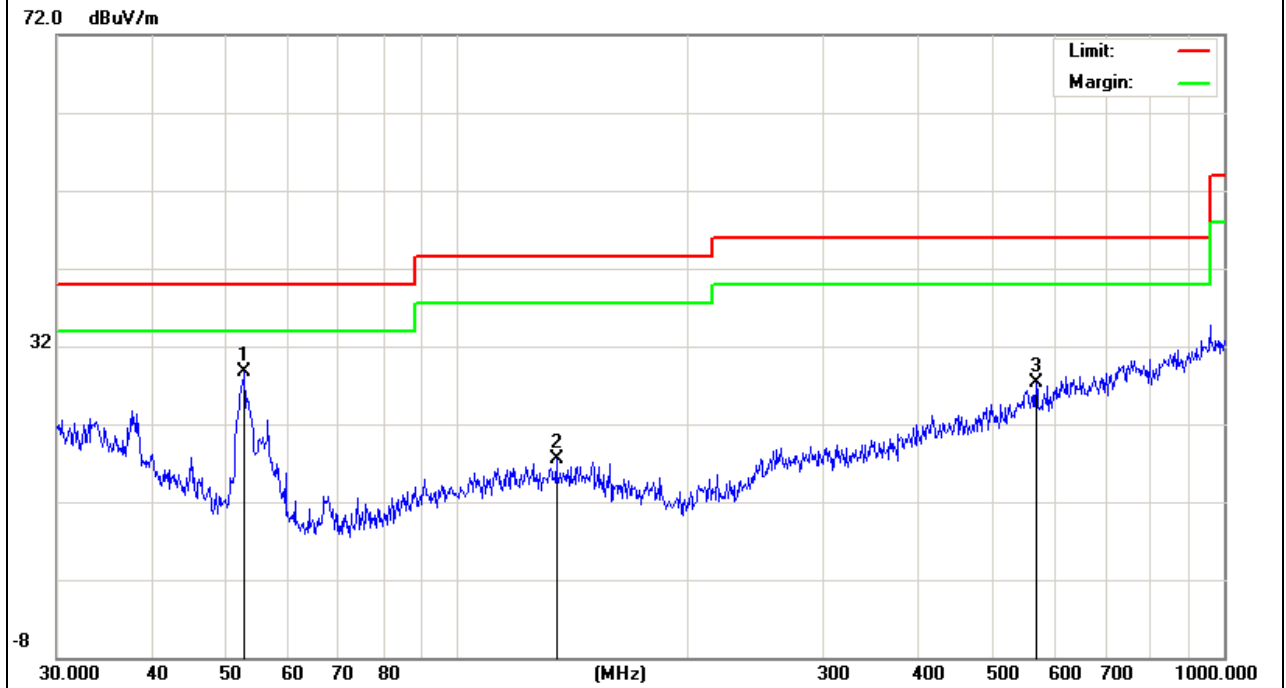

EUT :	Wireless Mouse	Model Name :	SL-630010-BK
Temperature :	20 °C	Relative Humidity :	48%
Pressure :	1010 hPa	Test Voltage :	DC 3.0V
Test Mode :	TX 2437MHz	Polarization :	Horizontal

Frequency (MHz)	Meter Reading (dBµV)	Factor (dB)	Emission Level (dBµV/m)	Limits (dBµV/m)	Margin (dB)	Detector Type
53.8817	12.91	6.45	19.36	40	-20.64	QP
128.1127	5.87	11.91	17.78	43.5	-25.72	QP
758.0407	6.25	24.36	30.61	46	-15.39	QP

Remark:

1. Factor = Antenna Factor + Cable Loss – Pre-amplifier.

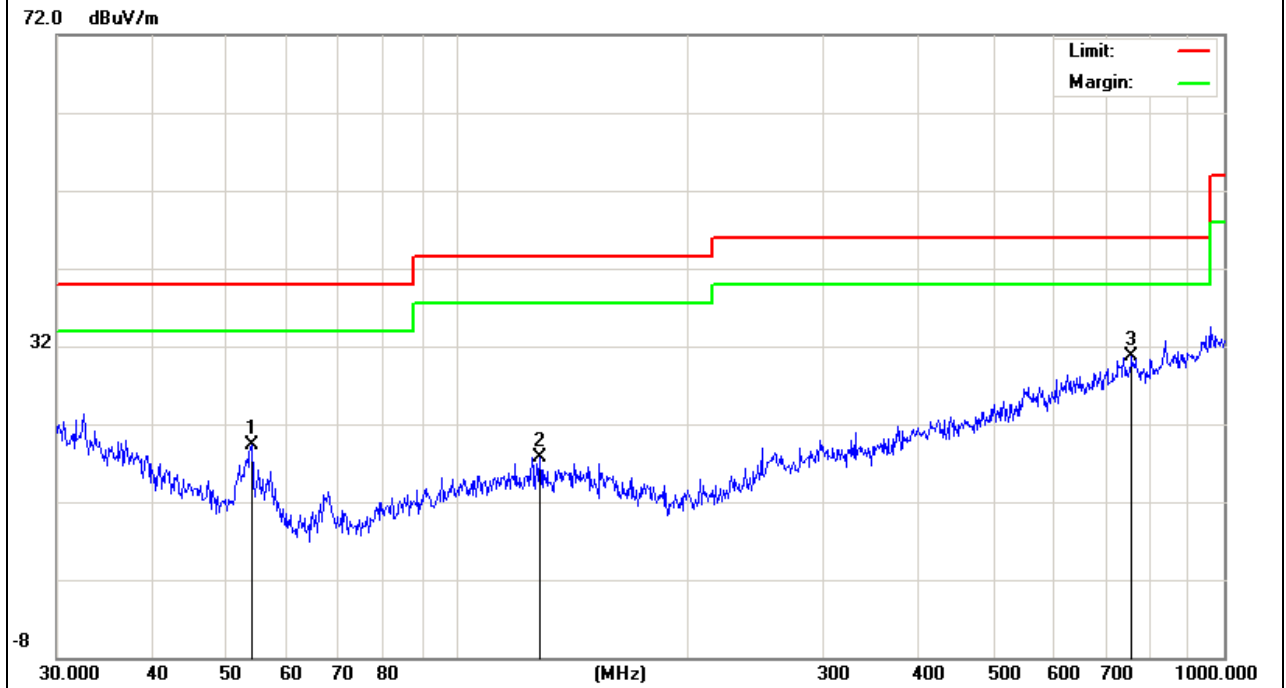

EUT :	Wireless Mouse	Model Name :	SL-630010-BK
Temperature :	20 °C	Relative Humidity :	48%
Pressure :	1010 hPa	Test Voltage :	DC 3.0V
Test Mode :	TX 2470MHz	Polarization :	Vertical

Frequency (MHz)	Meter Reading (dBµV)	Factor (dB)	Emission Level (dBµV/m)	Limits (dBµV/m)	Margin (dB)	Detector Type
44.9004	7.02	10.66	17.68	40	-22.32	QP
134.5592	5.45	11.98	17.43	43.5	-26.07	QP
406.088	7.72	17.48	25.2	46	-20.8	QP

Remark:

1. Factor = Antenna Factor + Cable Loss – Pre-amplifier.

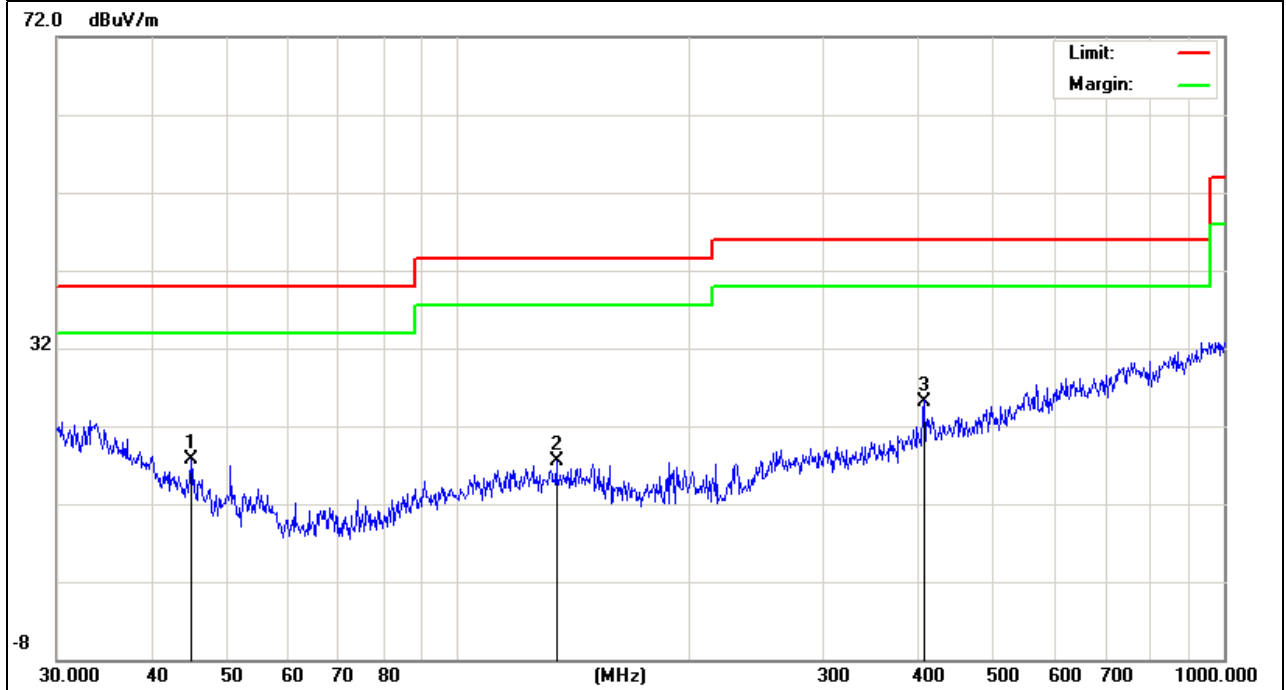

EUT :	Wireless Mouse	Model Name :	SL-630010-BK
Temperature :	20 °C	Relative Humidity :	48%
Pressure :	1010 hPa	Test Voltage :	DC 3.0V
Test Mode :	TX 2470MHz	Polarization :	Horizontal

Frequency (MHz)	Meter Reading (dBµV)	Factor (dB)	Emission Level (dBµV/m)	Limits (dBµV/m)	Margin (dB)	Detector Type
51.843	9.43	7.31	16.74	40	-23.26	QP
133.1511	7.94	11.96	19.9	43.5	-23.6	QP
446.4141	4.87	18.13	23	46	-23	QP

Remark:

1. Factor = Antenna Factor + Cable Loss – Pre-amplifier.

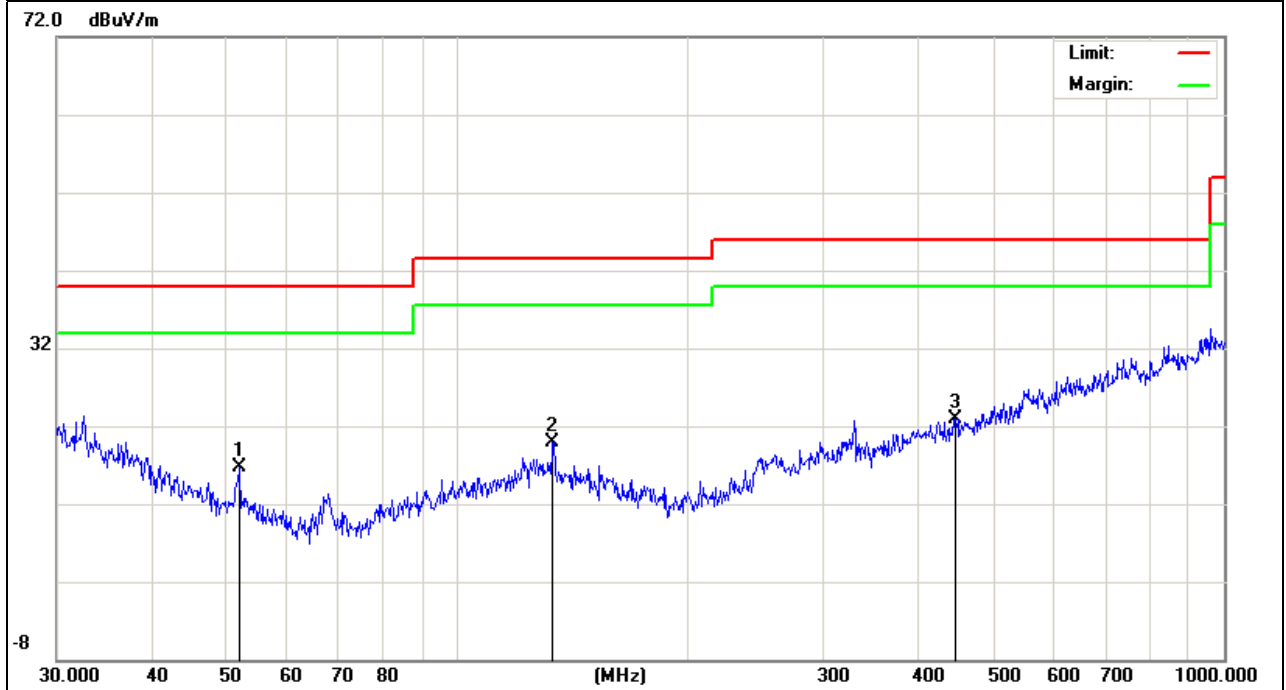

3.4.7 TEST RESULTS (ABOVE 1000 MHZ)

EUT :	Wireless Mouse	Model Name :	SL-630010-BK
Temperature :	20 °C	Relative Humidity :	48%
Pressure :	1010 hPa	Test Voltage :	DC 3.0V
Test Mode :	TX /2405MHz	Polarization :	Horizontal

Frequency (MHz)	Meter Reading (dBμV)	Factor (dB)	Emission Level (dBμV/m)	Limits (dBμV/m)	Margin (dB)	Detector Type
2405	93.39	-12.99	80.4	114.0 0	-33.6	peak
4810	52.58	-3.64	48.94	74	-25.06	peak

Remark:
 Factor = Antenna Factor + Cable Loss – Pre-amplifier.
 No emission detected in 18GHz~25GHz.

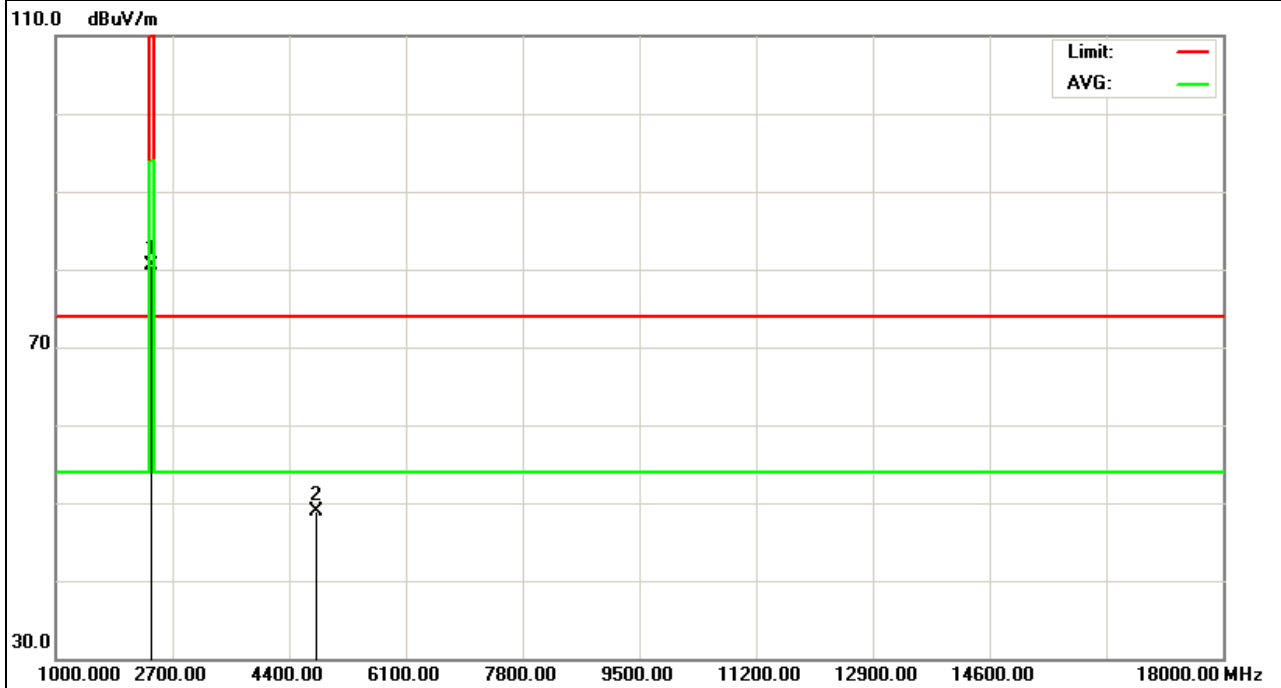

EUT :	2.4G Wireless Mouse	Model Name :	SL-630010-BK
Temperature :	20 °C	Relative Humidity :	48%
Pressure :	1010 hPa	Test Voltage :	DC 3.0V
Test Mode :	TX /2402MHz	Polarization :	Vertical

Frequency (MHz)	Meter Reading (dBµV)	Factor (dB)	Emission Level (dBµV/m)	Limits (dBµV/m)	Margin (dB)	Detector Type
2405	89.69	-12.99	76.7	114.0 0	-37.3	peak
4810	51.73	-3.64	48.09	74	-25.91	peak

Remark:
 Factor = Antenna Factor + Cable Loss – Pre-amplifier.
 No emission detected in 18GHz~25GHz .

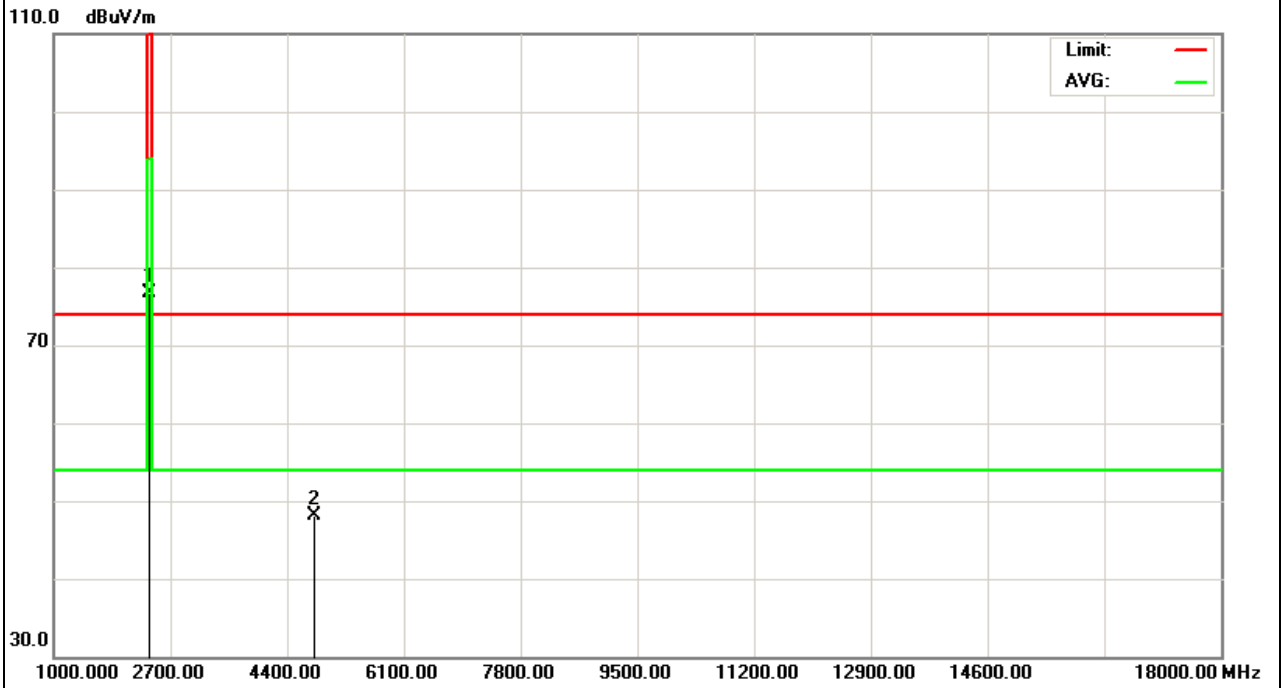

EUT :	Wireless Mouse	Model Name :	SL-630010-BK
Temperature :	20 °C	Relative Humidity :	48%
Pressure :	1010 hPa	Test Voltage :	DC 3.0V
Test Mode :	TX /2437MHz	Polarization :	Horizontal

Frequency (MHz)	Meter Reading (dBμV)	Factor (dB)	Emission Level (dBμV/m)	Limits (dBμV/m)	Margin (dB)	Detector Type
2437	92.77	-12.92	79.85	114.0 0	-34.15	peak
4874	54.22	-3.75	50.47	74	-23.53	peak

Remark:
 Factor = Antenna Factor + Cable Loss – Pre-amplifier.
 No emission detected in 18GHz~25GHz .

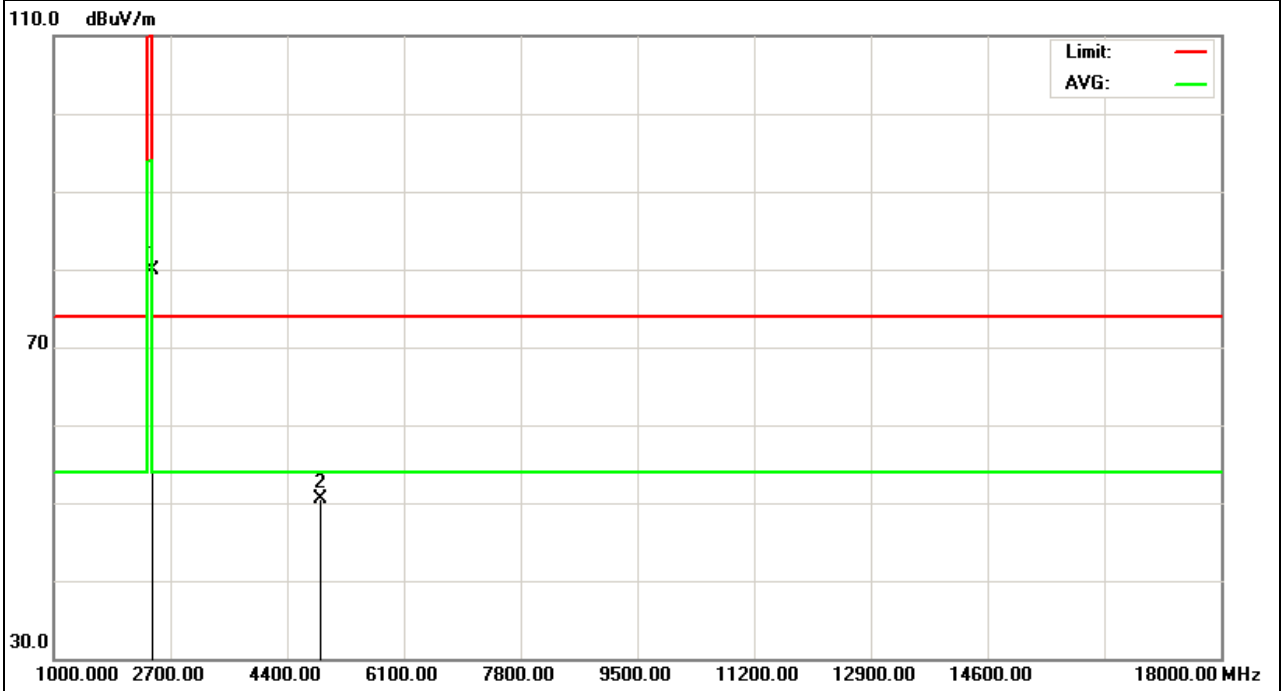

EUT :	Wireless Mouse	Model Name :	SL-630010-BK
Temperature :	20 °C	Relative Humidity :	48%
Pressure :	1010 hPa	Test Voltage :	DC 3.0V
Test Mode :	TX /2437MHz	Polarization :	Vertical

Frequency (MHz)	Meter Reading (dBµV)	Factor (dB)	Emission Level (dBµV/m)	Limits (dBµV/m)	Margin (dB)	Detector Type
2437	86.57	-12.92	73.65	114.0 0	-40.35	peak
4874	51.65	-3.75	47.9	74	-26.1	peak

Remark:
 Factor = Antenna Factor + Cable Loss – Pre-amplifier.
 No emission detected in 18GHz~25GHz .

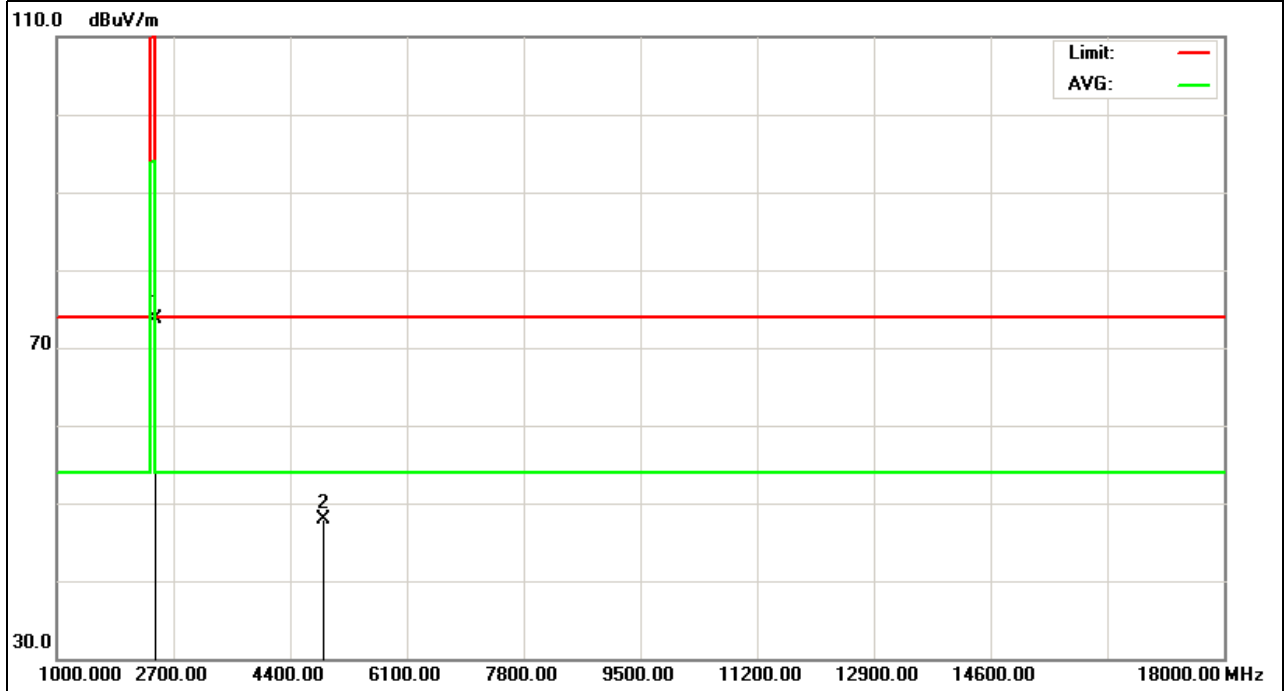

EUT :	Wireless Mouse	Model Name :	SL-630010-BK
Temperature :	20 °C	Relative Humidity :	48%
Pressure :	1010 hPa	Test Voltage :	DC 3.0V
Test Mode :	TX /2470MHz	Polarization :	Horizontal

Frequency (MHz)	Meter Reading (dBμV)	Factor (dB)	Emission Level (dBμV/m)	Limits (dBμV/m)	Margin (dB)	Detector Type
2470	85.61	-12.79	72.82	114.0 0	-41.18	peak
4940	50.63	-3.59	47.04	74	-26.96	peak

Remark:
 Factor = Antenna Factor + Cable Loss – Pre-amplifier.
 No emission detected in 18GHz~25GHz .

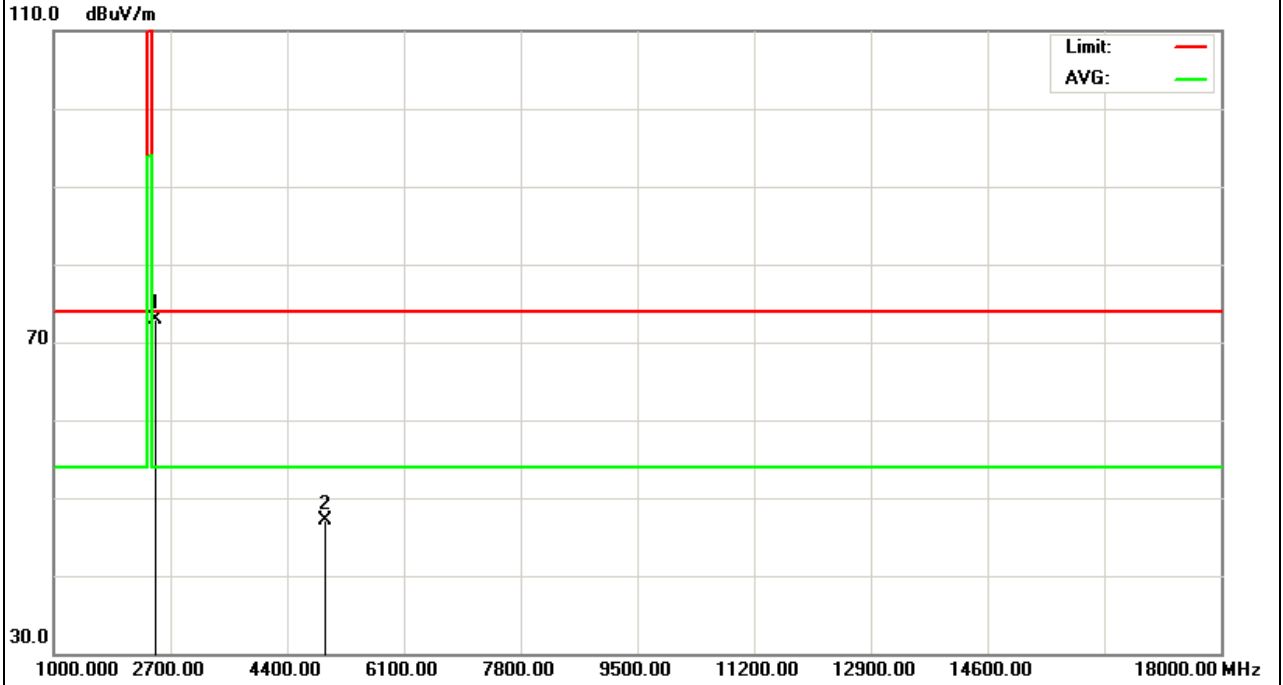

EUT :	Wireless Mouse	Model Name :	SL-630010-BK
Temperature :	20 °C	Relative Humidity :	48%
Pressure :	1010 hPa	Test Voltage :	DC 3.0V
Test Mode :	TX /2470MHz	Polarization :	Vertical

Frequency (MHz)	Meter Reading (dBμV)	Factor (dB)	Emission Level (dBμV/m)	Limits (dBμV/m)	Margin (dB)	Detector Type
2470	90.76	-12.79	77.97	114.0 0	-36.03	peak
4940	52.72	-3.59	49.13	74	-24.87	peak

Remark:
 Factor = Antenna Factor + Cable Loss – Pre-amplifier.
 No emission detected in 18GHz~25GHz .

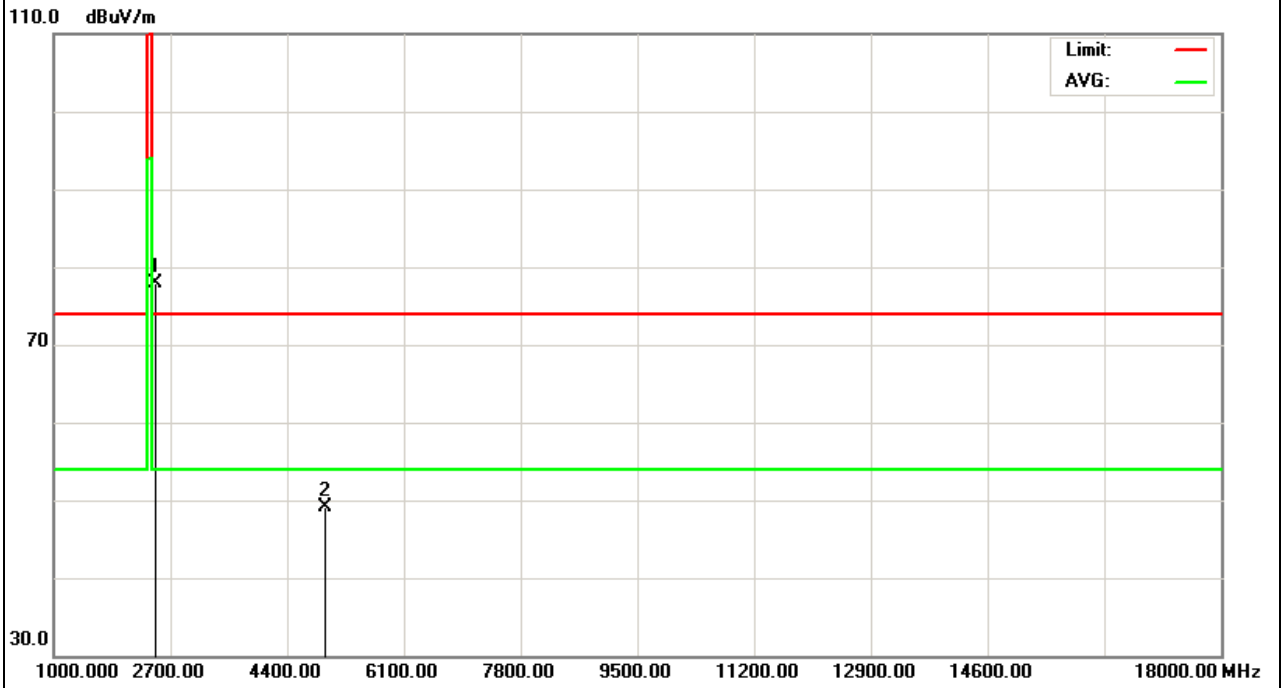

3.4.8 TEST RESULTS (RESTRICTED BANDS REQUIREMENTS)

EUT :	Wireless Mouse	Model Name :	SL-630010-BK
Temperature :	20 °C	Relative Humidity :	48%
Pressure :	1010 hPa	Test Voltage :	DC 3.0V
Test Mode :	TX /2405MHz	Polarization :	Vertical

Frequency (MHz)	Meter Reading (dBμV)	Factor (dB)	Emission Level (dBμV/m)	Limits (dBμV/m)	Margin (dB)	Detector Type
2310	41.39	-12.89	28.5	74	-45.5	peak
2375.175	61.49	-13.16	48.33	74	-25.67	peak
2390	45.81	-13.06	32.75	74	-41.25	peak
2400	63.51	-12.99	50.52	74	-23.48	peak

Remark:
Factor = Antenna Factor + Cable Loss – Pre-amplifier.

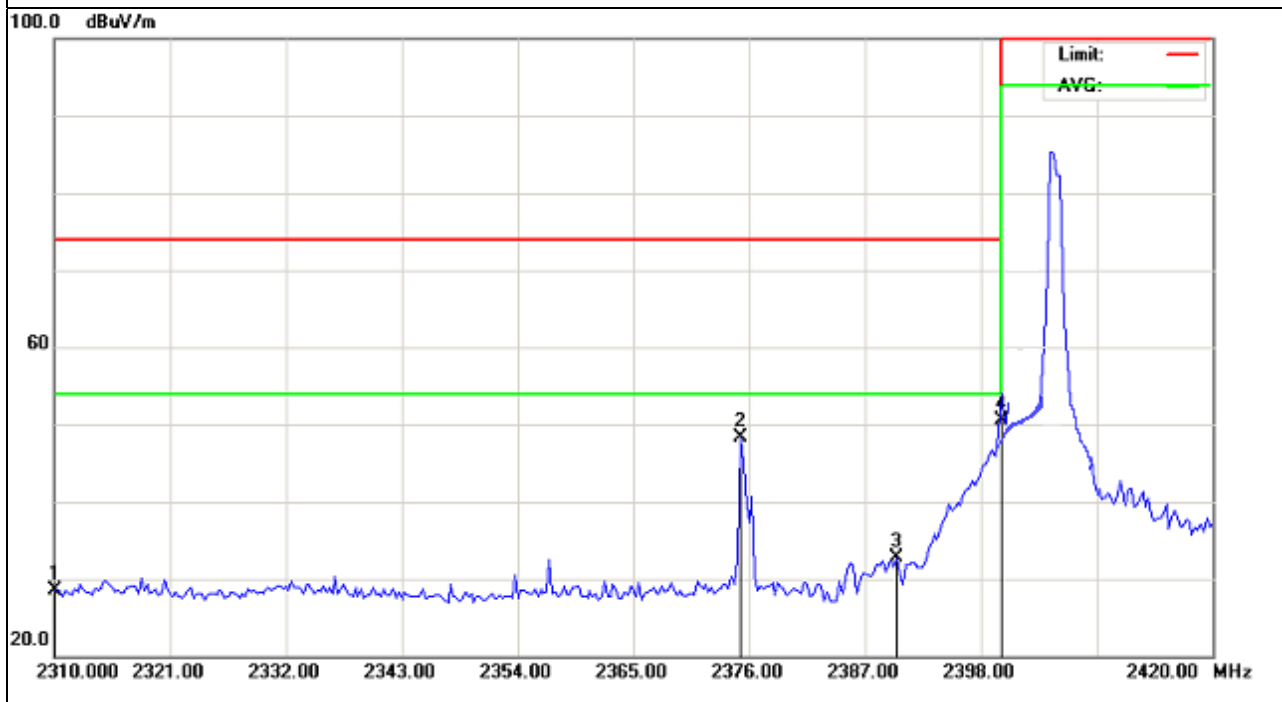

EUT :	Wireless Mouse	Model Name :	SL-630010-BK
Temperature :	20 °C	Relative Humidity :	48%
Pressure :	1010 hPa	Test Voltage :	DC 3.0V
Test Mode :	TX /2405MHz	Polarization :	Horizontal

Frequency (MHz)	Meter Reading (dBµV)	Factor (dB)	Emission Level (dBµV/m)	Limits (dBµV/m)	Margin (dB)	Detector Type
2310	42.21	-12.89	29.32	74	-44.68	peak
2390	41.04	-13.06	27.98	74	-46.02	peak
2400	61.8	-12.99	48.81	74	-25.19	peak

Remark:
 Factor = Antenna Factor + Cable Loss – Pre-amplifier.

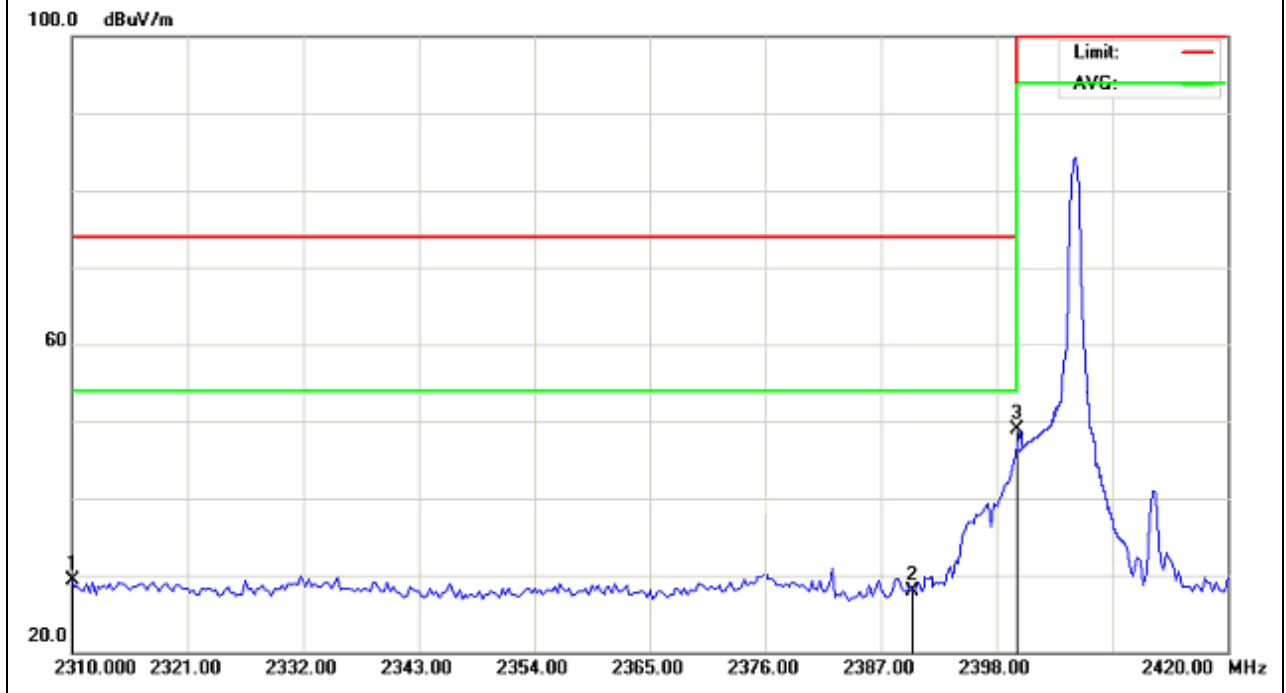

EUT :	Wireless Mouse	Model Name :	SL-630010-BK
Temperature :	20 °C	Relative Humidity :	48%
Pressure :	1010 hPa	Test Voltage :	DC 3.0V
Test Mode :	TX /2470MHz	Polarization :	Vertical

Frequency (MHz)	Meter Reading (dBμV)	Factor (dB)	Emission Level (dBμV/m)	Limits (dBμV/m)	Margin (dB)	Detector Type
2483.5	45.46	-12.78	32.68	74	-41.32	peak
2499	55.32	-12.72	42.6	74	-31.4	peak
2500	46.52	-12.72	33.8	74	-40.2	peak

Remark:
 Factor = Antenna Factor + Cable Loss – Pre-amplifier.

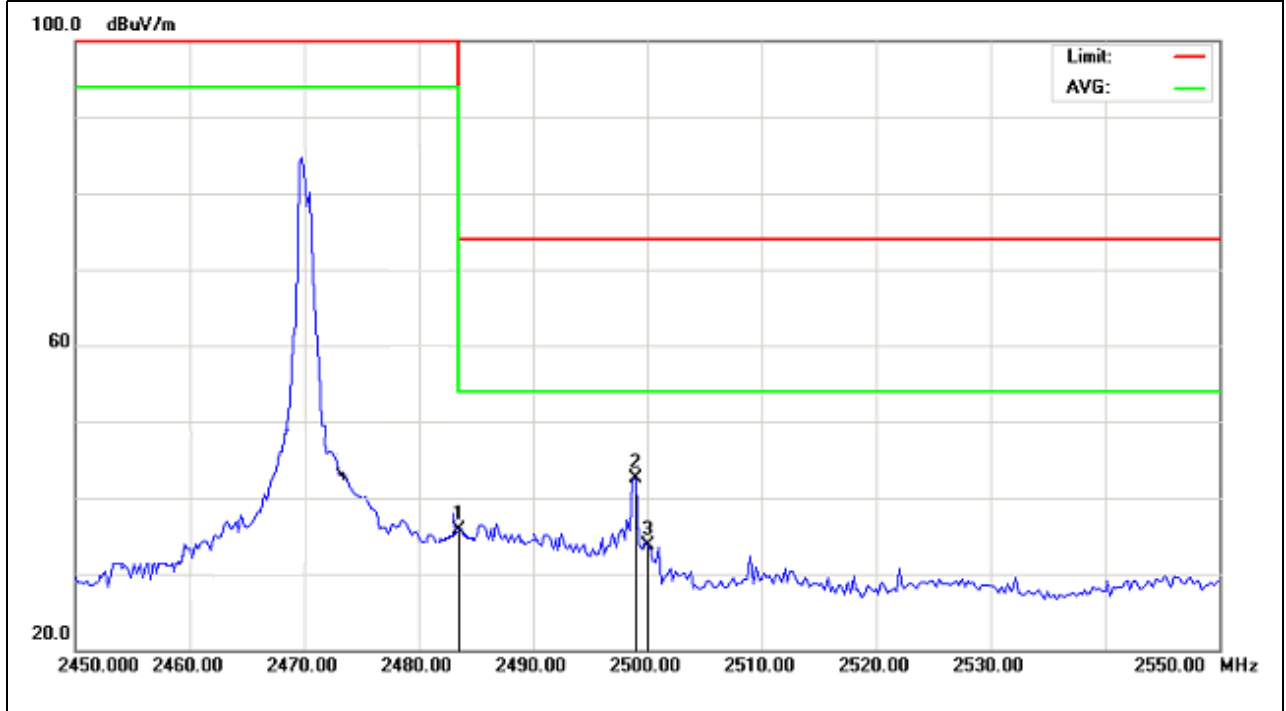

EUT :	2.4G Wireless Mouse	Model Name :	SL-630010-BK
Temperature :	20 °C	Relative Humidity :	48%
Pressure :	1010 hPa	Test Voltage :	DC 3.0V
Test Mode :	TX /2470MHz	Polarization :	Horizontal

Frequency (MHz)	Meter Reading (dBµV)	Factor (dB)	Emission Level (dBµV/m)	Limits (dBµV/m)	Margin (dB)	Detector Type
2483.5	48.15	-12.78	35.37	74	-38.63	peak
2497	43.03	-12.73	30.3	74	-43.7	peak
2500	40.32	-12.72	27.6	74	-46.4	peak

Remark:
 Factor = Antenna Factor + Cable Loss – Pre-amplifier.

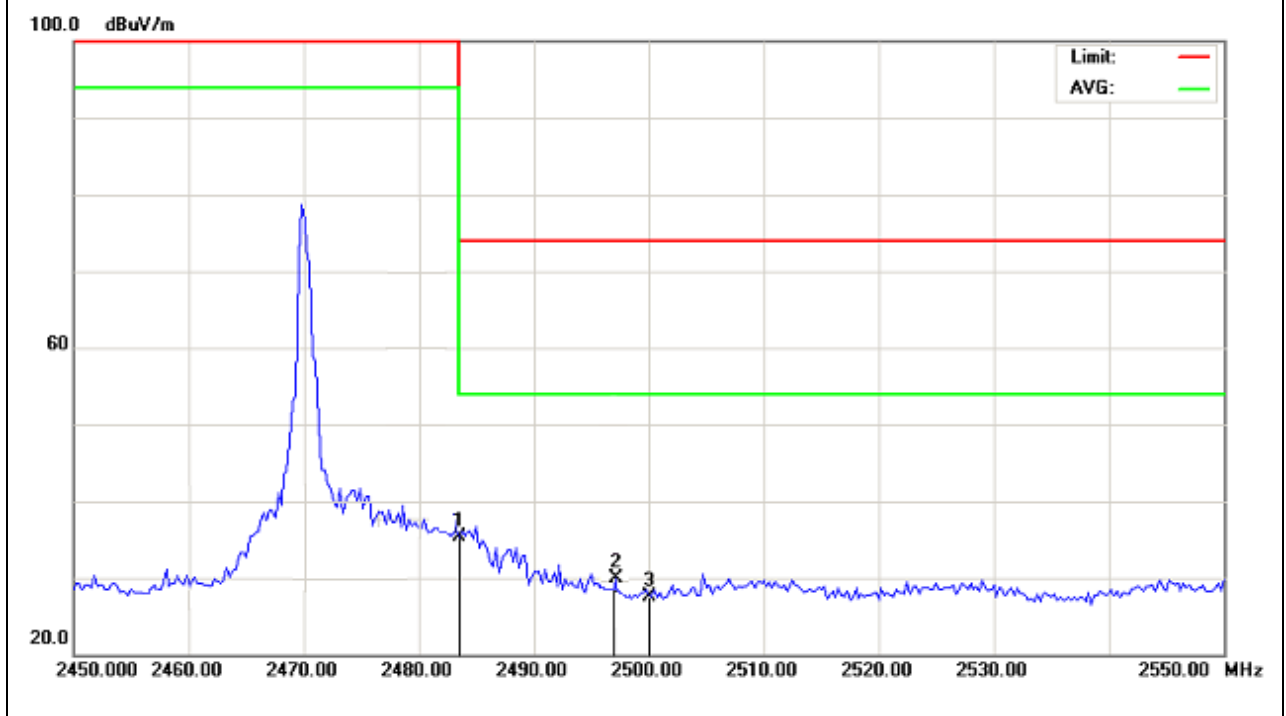

4. BANDWIDTH TEST

4.1 TEST PROCEDURE

- a. The EUT was directly connected to the spectrum analyzer and antenna output port as show in the block diagram below,
- b. Spectrum Setting : RBW= 100KHz, VBW \geq RBW, Sweep time = Auto.

4.2 DEVIATION FROM STANDARD

No deviation.

4.3 TEST SETUP



4.4 TEST RESULTS

EUT :	2.4G Wireless Mouse	Model Name :	SL-630010-BK
Temperature :	26 °C	Relative Humidity :	53%
Pressure :	1020 hPa	Test Power :	DC 3.0V
Test Mode :	TX CH 1/33/66		

Test Channel	Frequency (MHz)	20 dBc Bandwidth (MHz)	99% Bandwidth (MHz)
CH01	2405	0.433	0.405
CH33	2437	0.410	0.422
CH66	2470	0.415	0.453

The Lowest Channel: 2405MHz

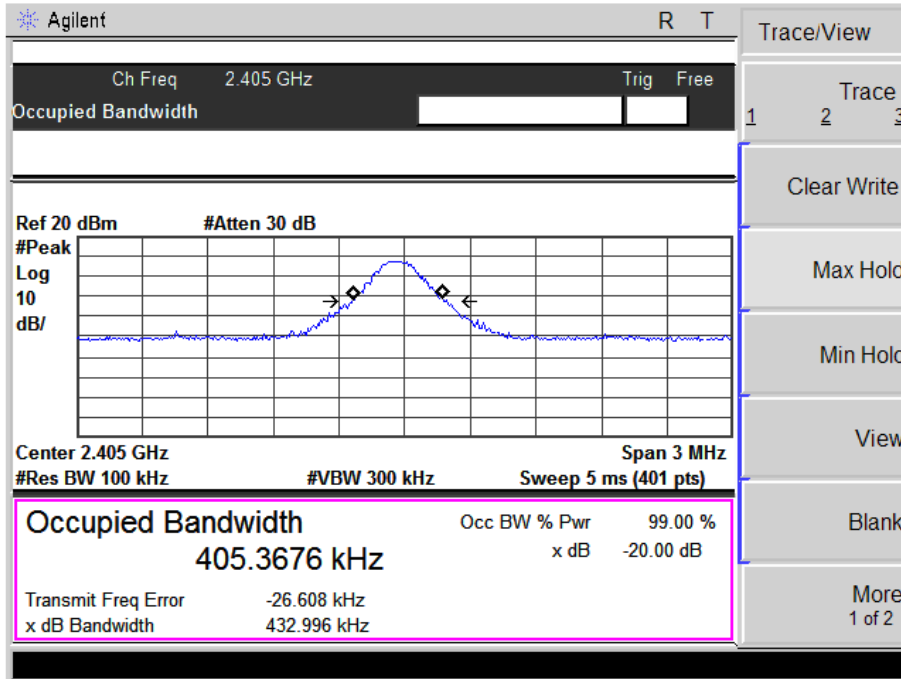

The Middle Channel: 2437MHz

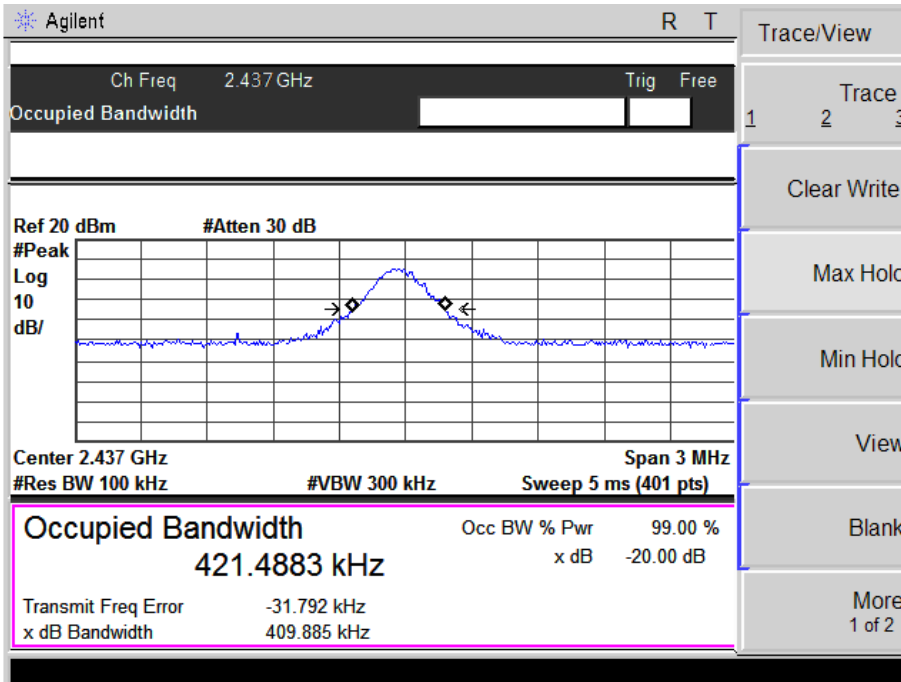

The High Channel:2470MHz

