



Total Quality. Assured.

Intertek
731 Enterprise Drive
Lexington, KY 40510

Tel 859 226 1000
Fax 859 226 1040

www.intertek.com

Ubicquia, Inc. TEST REPORT

SCOPE OF WORK

EMC TESTING – UBIHUB APAI

REPORT NUMBER

104626259LEX-005.3

ISSUE DATE

10/7/2021

REVISION DATE

5/10/2022

PAGES

70

DOCUMENT CONTROL NUMBER

Non-Specific EMC Report Shell Rev. December 2017
© 2017 INTERTEK



EMC TEST REPORT
(FULL COMPLIANCE)

Report Number: 104626259LEX-005.3

Project Number: G104626259

Report Issue Date: 10/7/2021

Report Revised Date: 5/10/2022

Product Tested: UbiHub APAI

Model Number: UBH-H-AI

Standards: FCC Part 15 Subpart E
RSS-247 Issue 2

Tested by:
Intertek Testing Services NA, Inc.
731 Enterprise Dr.
Lexington, KY 40510
USA

Client:
Ubicquia, Inc.
401 Eas Las Olas Blvd.
Suite 1750
Fort Lauderdale, FL 33301
USA

Report prepared by



Brian Lackey, Team Leader

Report reviewed by



James Sudduth, Senior Staff Engineer

This report is for the exclusive use of Intertek's Client and is provided pursuant to the agreement between Intertek and its Client. Intertek's responsibility and liability are limited to the terms and conditions of the agreement. Intertek assumes no liability to any party, other than to the Client in accordance with the agreement, for any loss, expense or damage occasioned by the use of this report. Only the Client is authorized to copy or distribute this report and then only in its entirety. Any use of the Intertek name or one of its marks for the sale or advertisement of the tested material, product or service must first be approved in writing by Intertek. The observations and test results in this report are relevant only to the sample tested. This report by itself does not imply that the material, product, or service is or has ever been under an Intertek certification program.





Table of Contents

1	<i>Introduction and Conclusion</i>	4
2	<i>Test Summary</i>	5
3	<i>Client Information</i>	7
4	<i>Description of Equipment under Test and Variant Models</i>	8
5	<i>System Setup and Method</i>	10
6	<i>Measurement Procedures and Determination of Worst-Case Modes</i>	13
7	<i>Occupied Bandwidth Data</i>	14
8	<i>Output Power Data</i>	16
9	<i>Power Spectral Density Data</i>	20
10	<i>U-NII-1 Radiated Spurious Emissions</i>	22
11	<i>U-NII-2A Radiated Spurious Emissions</i>	33
12	<i>U-NII-2C Radiated Spurious Emissions</i>	42
13	<i>U-NII-3 Radiated Spurious Emissions</i>	53
14	<i>Radiated Band Edge Emissions</i>	62
15	<i>Revision History</i>	70



1 Introduction and Conclusion

The tests indicated below were performed on the product described in section 4. The remaining test sections are the verbatim text from the actual data sheets used during the investigation. No additions, deviations, or exclusions have been made from the standard(s) unless specifically noted.

Based on the results of our investigation, we have concluded the product tested **complies** with the requirements of the standard(s) indicated. The results obtained in this test report pertain only to the item(s) tested. Intertek does not make any claims of compliance for samples or variants which were not tested.



2 Test Summary

U-NII-1 (5150 – 5250MHz)						
FCC Rule	ISED Rule	Test Method	Test Description	Measured Value	Limit	Results
15.407a(1)	RSS-247 (6.2.1)	ANSI C63.10 (12.4)	26dB Bandwidth	802.11a: 22.11MHz 802.11n: 21.07MHz 802.11n(40MHz): 40.75MHz 802.11ac (80MHz): 83.01MHz	None	Pass
15.407a(1)	RSS-247 (6.2.1)	ANSI C63.10 (12.4)	99% Bandwidth	802.11a: 16.91MHz 802.11n: 17.71MHz 802.11n(40MHz): 36.05MHz 802.11ac (80MHz): 75.64MHz	None	Pass
15.407a(1)	RSS-247 (6.2.1)	ANSI C63.10 (12.3)	Maximum Conducted Output Power	802.11a: 21.8dBm 802.11n: 22.02dBm 802.11n(40MHz): 21.47dBm 802.11ac (80MHz): 13.35dBm	30dBm – 7.6dB for array gain adjustment	Pass
15.407a(1)	RSS-247 (6.2.1)	ANSI C63.10 (12.5)	Power Spectral Density	802.11a: 9.2dBm/MHz 802.11n: 8.78dBm/MHz 802.11n(40MHz): 8.59dBm/MHz 802.11ac (80MHz): 5.67dBm/MHz	17dBm/MHz – 7.6dB for array gain adjustment	Pass
15.407b(1)	RSS-247 (6.2.1)	ANSI C63.10 (12.7)	Undesirable Emissions	802.11a: 53.91dBuV/m 802.11n: 51.93dBuV/m 802.11n(40MHz): 53.49dBuV/m 802.11ac (80MHz): 53.47dBuV/m	-27dBm/MHz (68.25dBuV/m, 3m)	Pass

U-NII-2A (5250 – 5350MHz)						
FCC Rule	ISED Rule	Test Method	Test Description	Measured Value	Limit	Results
15.407a(2)	RSS-247 (6.2.2)	ANSI C63.10 (12.4)	26dB Bandwidth	802.11a: 22.03MHz 802.11n: 21.07MHz 802.11n(40MHz): 41.02MHz 802.11ac (80MHz): 82.69MHz	None	Pass
15.407a(2)	RSS-247 (6.2.2)	ANSI C63.10 (12.4)	99% Bandwidth	802.11a: 16.82MHz 802.11n: 17.71MHz 802.11n(40MHz): 36.21MHz 802.11ac (80MHz): 75.32MHz	None	Pass
15.407a(2)	RSS-247 (6.2.2)	ANSI C63.10 (12.3)	Maximum Conducted Output Power	802.11a: 16.12dBm 802.11n: 16.03dBm 802.11n(40MHz): 16.18dBm 802.11ac (80MHz): 15.68dBm	24dBm – 7.6dB for array gain adjustment	Pass
15.407a(2)	RSS-247 (6.2.2)	ANSI C63.10 (12.5)	Power Spectral Density	802.11a: 3.32dBm/MHz 802.11n: 3.03dBm/MHz 802.11n(40MHz): 3.13dBm/MHz 802.11ac (80MHz): -0.97dBm/MHz	11dBm/MHz – 7.6dB for array gain adjustment	Pass
15.407b(2)	RSS-247 (6.2.2)	ANSI C63.10 (12.7)	Undesirable Emissions	802.11a: 53.42dBuV/m 802.11n: 51.41dBuV/m 802.11n(40MHz): 48.58dBuV/m 802.11ac (80MHz): 52.99dBuV/m	-27dBm/MHz (68.25dBuV/m, 3m)	Pass



U-NII-2C (5470 – 5725MHz)						
FCC Rule	ISED Rule	Test Method	Test Description	Measured Value	Limit	Results
15.407a(2)	RSS-247 (6.2.2)	ANSI C63.10 (12.4)	26dB Bandwidth	802.11a: 21.95MHz 802.11n: 21.07MHz 802.11n(40MHz): 41.18MHz 802.11ac (80MHz): 83.01MHz	None	Pass
15.407a(2)	RSS-247 (6.2.2)	ANSI C63.10 (12.4)	99% Bandwidth	802.11a: 16.82MHz 802.11n: 17.71MHz 802.11n(40MHz): 36.37MHz 802.11ac (80MHz): 75.64MHz	None	Pass
15.407a(2)	RSS-247 (6.2.2)	ANSI C63.10 (12.3)	Maximum Conducted Output Power	802.11a: 16.17dBm 802.11n: 16.14dBm 802.11n(40MHz): 16.18dBm 802.11ac (80MHz): 16.03dBm	24dBm – 7.6dB for array gain adjustment	Pass
15.407a(2)	RSS-247 (6.2.2)	ANSI C63.10 (12.5)	Power Spectral Density	802.11a: 3.23dBm/MHz 802.11n: 3.12dBm/MHz 802.11n(40MHz): 2.91dBm/MHz 802.11ac (80MHz): 2.91dBm/MHz	11dBm/MHz – 7.6dB for array gain adjustment	Pass
15.407b(3)	RSS-247 (6.2.2)	ANSI C63.10 (12.7)	Undesirable Emissions	802.11a: 53.22dBuV/m 802.11n: 51.95dBuV/m 802.11n(40MHz): 51.86dBuV/m 802.11ac (80MHz): 52.19dBuV/m	-27dBm/MHz (68.25dBuV/m, 3m)	Pass

U-NII-3(5725 – 5825MHz)						
FCC Rule	ISED Rule	Test Method	Test Description	Measured Value	Limit	Results
15.407a(3)	RSS-247 (6.2.3)	ANSI C63.10 (12.4)	26dB Bandwidth	802.11a: 23.79MHz 802.11n: 20.99MHz 802.11n(40MHz): 41.02MHz 802.11ac (80MHz): 83.01MHz	None	Pass
15.407a(3)	RSS-247 (6.2.3)	ANSI C63.10 (12.4)	99% Bandwidth	802.11a: 16.91MHz 802.11n: 17.71MHz 802.11n(40MHz): 36.21MHz 802.11ac (80MHz): 75.64MHz	None	Pass
15.407a(3)	RSS-247 (6.2.3)	ANSI C63.10 (12.4)	6dB Bandwidth	802.11a: 16.74MHz 802.11n: 17.54MHz 802.11n(40MHz): 36.53MHz 802.11ac (80MHz): 75.96MHz	>500kHz	Pass
15.407a(3)	RSS-247 (6.2.3)	ANSI C63.10 (12.3)	Maximum Conducted Output Power	802.11a: 22.12dBm 802.11n: 22.3dBm 802.11n(40MHz): 22.30dBm 802.11ac (80MHz): 21.88 dBm	30dBm – 7.6dB for array gain adjustment	Pass
15.407a(3)	RSS-247 (6.2.3)	ANSI C63.10 (12.5)	Power Spectral Density	802.11a: 18.63dBm/500kHz 802.11n: 16.07dBm/kHz 802.11n(40MHz): 12.10dBm/500kHz 802.11ac (80MHz): 8.49dBm/500kHz	30dBm/500kHz - 7.6dBm for array gain adjustment	Pass
15.407b(4)	RSS-247 (6.2.3)	ANSI C63.10 (12.7)	Undesirable Emissions	802.11a: 53.43dBuV/m 802.11n: 51.14dBuV/m 802.11n(40MHz): 51.71dBuV/m 802.11ac (80MHz): 51.29dBuV/m	-27dBm/MHz (68.25dBuV/m, 3m)	Pass



3 Client Information

This product was tested at the request of the following:

Client Information	
Client Name:	Ubicquia, Inc.
Address:	401 Eas Las Olas Blvd. Suite 1750 Fort Lauderdale, FL 33301 USA
Contact:	Shimon Goldstein
Telephone:	(954) 774-6213
Email:	sgoldstein@ubicquia.com
Manufacturer Information	
Manufacturer Name:	Ubicquia, Inc.
Manufacturer Address:	401 Eas Las Olas Blvd. Suite 1750 Fort Lauderdale, FL 33301 USA

**4 Description of Equipment under Test and Variant Models**

Equipment Under Test									
Product Name	UbiHub APAI								
Model Number	UBH-H-AI								
Serial Number	Test Sample 1								
Receive Date	6/1/2021								
Test Start Date	6/2/2021								
Test End Date	2/21/2022								
Transmit Bands Supported	U-NII-1, 5150 – 5250MHz U-NII-2A, 5250 – 5350MHz U-NII-2C, 5470 – 5725MHz U-NII-3, 5725 – 5850MHz								
Modulation Types Supported	802.11n, 802.11a ,802.11ac, 802.11ax								
Antenna Information	Manufacturer: Taoglas Part Number XP524.D.07.C.001								
	Two of these antennas were used in a 8x8MIMO configuration. Each of the 8 individual antenna paths had gains as follows:								
	<table border="1"> <tbody> <tr> <td>Antenna 1: 4.2dBi</td> <td>Antenna 5: 4.2dBi</td> </tr> <tr> <td>Antenna 2: 5.7dBi</td> <td>Antenna 6: 5.7dBi</td> </tr> <tr> <td>Antenna 3: 4.4dBi</td> <td>Antenna 7: 4.4dBi</td> </tr> <tr> <td>Antenna 4: 3.9dBi</td> <td>Antenna 8: 3.9dBi</td> </tr> </tbody> </table>	Antenna 1: 4.2dBi	Antenna 5: 4.2dBi	Antenna 2: 5.7dBi	Antenna 6: 5.7dBi	Antenna 3: 4.4dBi	Antenna 7: 4.4dBi	Antenna 4: 3.9dBi	Antenna 8: 3.9dBi
	Antenna 1: 4.2dBi	Antenna 5: 4.2dBi							
Antenna 2: 5.7dBi	Antenna 6: 5.7dBi								
Antenna 3: 4.4dBi	Antenna 7: 4.4dBi								
Antenna 4: 3.9dBi	Antenna 8: 3.9dBi								
Array gain calculations for correlated outputs with unequal antenna gains yielded an effective array gain of 13.6dBi. Reference KDB662911 D01 Section F. 2. d for the methodology used to calculate the array gain									
Device Received Condition	Good								
Test Sample Type	Production								
Ratings	90 – 504VAC, 50/60Hz, 95W								
Description of Equipment Under Test (provided by client)									
UbiHub is a smart streetlight controller with support for WiFi6 (802.11ax) 5Ghz 8x8 configuration, as well as 2.4Ghz 4x4 configuration, and LTE backhaul (via pre-approved LTE Module: EG25-G or EP06-A).									



4.1 Variant Models:

UbiHub is a smart streetlight controller with two versions (with and without optional AI plug in daughterboard). Both versions have the same AP and enable lighting controls and high-speed internet access. The APAI model version additionally provides AI analysis for street traffic.

- The UbiHub Family of products supports 2 different Model Names: UbiHub APAI and UbiHub AP6
- **AP6:** The AP6 Model (UBH-H-WI) supports full WiFi6 (802.11ax) 5Ghz 8x8 configuration, as well as 2.4Ghz 4x4 configuration, and LTE backhaul (via LTE Module: EG25-G or EP06-A).
- **APAI:** The APAI Model (UBH-H-AI) supports identical AP6 functionality (hardware and software), but in addition supports audio/video street traffic analytics via an AI plug-in daughterboard.

All testing in this report was performed on the APAI version since it is more densely populated than the AP6 version. The differences between the AP6 and APAI versions are only in non-transmitter related circuitry so the results within this report should also apply to the AP6 version.



5 System Setup and Method

No.	Descriptions of EUT Exercising
1	The UbiHub APAI was connected to a laptop computer via a router. The laptop was used to send test commands to the UbiHub APAI to force it to transmit on low, mid, or high channels at maximum output power.

Cables					
Qty	Description	Length	Shielding	Ferrites	Termination
1	AC Input	2m	None	None	AC Power Source
1	Ethernet Cable	2m	None	None	Router

Support Equipment			
Description	Manufacturer	Model Number	Serial Number
Laptop	HP	ProBook 455 G4	5CD7212NFW
Router	Belkin	F9K1115V2	14502GM5200027

5.1 Block Diagram:

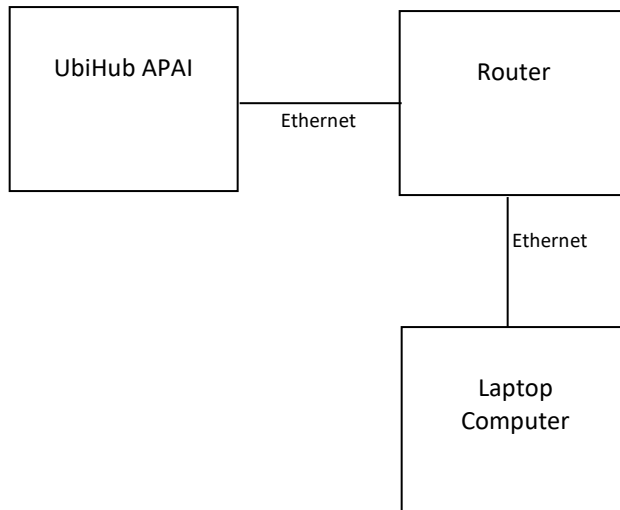



5.2 Test Channels:

The following test channels were used during the evaluation:

TX Mode	Band	TX Channels	TX Frequencies (MHz)
20MHz Wide	U-NII-1	36, 44, 48	5180, 5220, 5240
	U-NII-2A	52, 60, 64	5260, 5300, 5320
	U-NII-2C	100, 116, 140	5500, 5580, 5700
	U-NII-3	149, 157, 165	5745, 5785, 5825
40MHz Wide	U-NII-1	38, 46	5190, 5230
	U-NII-2A	54, 62	5270, 5310
	U-NII-2C	102, 110, 134	5510, 5550, 5670
	U-NII-3	151, 159	5755, 5795
80MHz Wide	U-NII-1	42	5210
	U-NII-2A	58	5290
	U-NII-2C	106, 138	5530, 5690
	U-NII-3	155	5775

5.3 U-NII Bands / Channels:

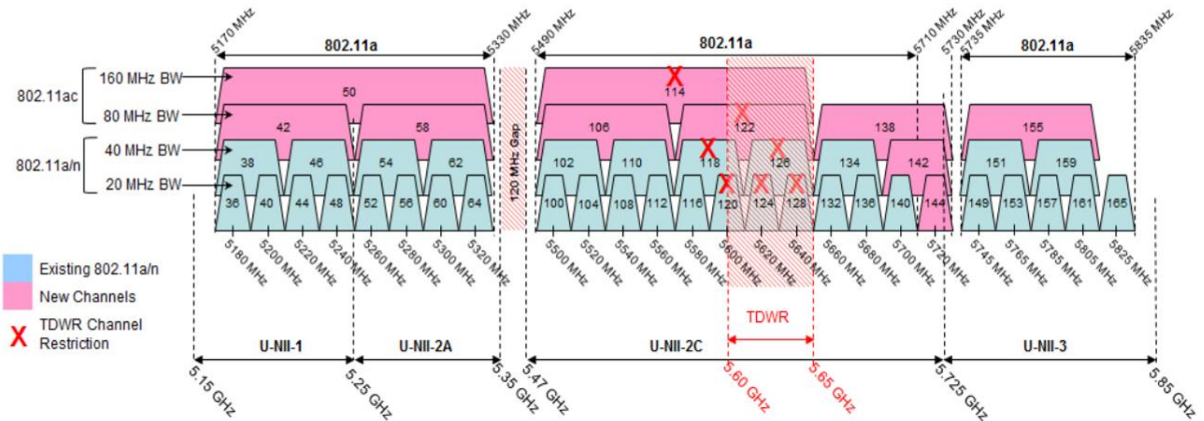

**5.4 Test Equipment Used (Conducted Antenna Port Tests):**

Description	Asset	Manufacturer	Model	Cal Date	Cal Due
Wideband Power Sensor	4022	Rohde&Schwarz	NRP-Z81	9/22/2020	9/22/2021
Spectrum Analyzer	3720	Rohde&Schwarz	FSEK30	10/13/2020	10/13/2021
Spectrum Analyzer	3981	Rohde&Schwarz	FSU8	9/22/2020	9/22/2021

5.5 Test Equipment Used (Conducted AC Input Tests):

Description	Asset	Manufacturer	Model	Cal Date	Cal Due
EMI Test Receiver	2327	Rohde & Schwarz	ESI26	10/9/2020	10/9/2021
LISN	2508	Fischer Custom Communication	FCC-LISN-50-50-2M	6/22/2021	6/22/2022
Coaxial Cable	7024			12/21/2020	12/21/2021

5.6 Test Equipment Used (Radiated Tests):

Description	Asset	Manufacturer	Model	Cal Date	Cal Due
EMI Test Receiver	3900	Rohde&Schwarz	ESU40	10/5/2020	10/5/2021
Magnetic Loop Antenna	2366	ETS	6502	7/17/2020	7/17/2021
Bilog Antenna (JB6)	7085	SunAR	JB6	9/4/2020	9/4/2021
Horn Antenna (1-18GHz)	4001	ETS	3117	1/26/2021	1/26/2022
Horn Antenna (18-40GHz)	3779	ETS	3116c	7/23/2020	7/23/2021
Preamplifier (18-40GHz)	3921	Rohde & Schwarz	TS-PR40	12/21/2020	12/21/2021
Coaxial Cable (40GHz)	7020			12/21/2020	12/21/2021
Coaxial Cable (40GHz)	7021			12/21/2020	12/21/2021
System Controller	4096	ETS Lindgren	2090	Verify at Time of Use	Verify at Time of Use
System Controller	3957	Sunol Sciences	SC99V	Verify at Time of Use	Verify at Time of Use
Coaxial Cable	3074			12/21/2020	12/21/2021
3m Cable Preamplifier	3918	Rohde&Schwarz	TS-PR18	12/21/2020	12/21/2021
Coaxial Cable	2588			12/21/2020	12/21/2021
Coaxial Cable	2593			12/21/2020	12/21/2021
Coaxial Cable	2592			12/21/2020	12/21/2021
Coaxial Cable	3339			12/21/2020	12/21/2021

5.7 Software Utilized:

Name	Manufacturer	Version
EMC32	Rohde&Schwarz	Version 9.15.02
TILE7	ETS Lindgren	Version 7.0.6.545
GPIBSHOT	Rohde&Schwarz	Version 2.7.2
Power Viewer Plus	Rohde&Schwarz	Version 6.1



6 Measurement Procedures and Determination of Worst-Case Modes

The occupied bandwidth, power spectral density, and conducted output power measurements were all performed with the UbiHub APAI connected to a spectrum analyzer. Measurements were performed per the procedures outlined in ANSI C63.10: 2013. See the summary tables for specific references to the appropriate sections that were used.

The output power measurements were performed with the UbiHub APAI connected to a wideband power meter.

For the conducted power and power spectral density measurements an array gain was added to the final measurements in order to account for the multiple transmit ports. For 8 correlated output ports with unequal antenna gains this factor was 13.6dB. Reference KDB662911 D01 Section F. 2. d for the methodology used to calculate the array gain.

For radiated spurious emission measurements, testing was performed with the bandwidth setting and modulation that produced the highest output power. The frequency spectrum was investigated from 9kHz to at least 10 times the highest frequency used or generated in the device or 40GHz (whichever was lower).

Testing was performed for the lowest order modulation for each transmit mode as well as for each transmit bandwidth supported as these present the worst case in terms of spurious emissions and output power.

**7 Occupied Bandwidth Data**

U-NII-I Bandwidth Measurements				
TX Mode	Ch. No.	Freq (MHz)	26dB BW (MHz)	99% BW (MHz)
802.11a	36	5180	22.11	16.82
	44	5220	21.71	16.91
	48	5240	22.11	16.82
802.11n (HT20)	36	5180	21.07	17.62
	44	5220	20.83	17.71
	48	5240	20.99	17.71
802.11n (HT40)	38	5190	40.75	36.05
	46	5230	40.7	36.05
802.11ac (VHT80)	42	5210	83.01	75.64

U-NII-2A Bandwidth Measurements				
TX Mode	Ch. No.	Freq (MHz)	26dB BW (MHz)	99% BW (MHz)
802.11a	52	5260	22.03	16.74
	60	5300	21.55	16.82
	64	5320	21.79	16.82
802.11n (HT20)	52	5260	21.07	17.71
	60	5300	20.67	17.62
	64	5320	20.83	17.71
802.11n (HT40)	54	5270	41.02	36.21
	62	5310	40.7	36.05
802.11ac (VHT80)	58	5290	82.69	75.32

U-NII-2C Bandwidth Measurements				
TX Mode	Ch. No.	Freq (MHz)	26dB BW (MHz)	99% BW (MHz)
802.11a	100	5500	21.87	16.82
	116	5580	21.87	16.82
	140	5700	21.95	16.82
802.11n (HT20)	100	5500	20.91	17.62
	116	5580	20.75	17.71
	140	5700	21.07	17.71
802.11n (HT40)	102	5510	41.18	36.21
	110	5550	41.02	36.37
	134	5670	41.18	36.12
802.11ac (VHT80)	106	5530	83.01	75.64
	138	5690	83.01	75.64



U-NII-3 Bandwidth Measurements					
TX Mode	Ch. No.	Freq (MHz)	6dB BW (MHz)	26dB BW (MHz)	99% BW (MHz)
802.11a	149	5745	16.66	21.55	16.82
	157	5785	16.66	22.11	16.82
	165	5825	16.74	23.79	16.91
802.11n (HT20)	149	5745	17.38	20.67	17.71
	157	5785	17.54	20.83	17.62
	165	5825	17.54	20.99	17.71
802.11n (HT40)	151	5755	36.37	41.02	36.21
	159	5795	36.53	40.54	36.21
802.11ac (VHT80)	155	5775	75.96	83.01	75.64

Test Personnel: Bryan Taylor
Supervising/Reviewing Engineer: _____
(Where Applicable) NA
FCC Part 15E
Product Standard: RSS-247 Issue 2
Input Voltage: 120VAC / 60Hz
Pretest Verification w / Ambient
Signals or BB Source: Yes

Test Date: 7/13/2021 – 7/19/2021
6dB Bandwidth \geq 500kHz (U-NII-3
Limit Applied: Band)
Ambient Temperature: 22.6C
Relative Humidity: 41.2%
Atmospheric Pressure: 991.2mbar

Deviations, Additions, or Exclusions: None



8 Output Power Data (8x8 MIMO Operation)

Since the directional antenna gain is 13.6 dBi the limits in the following tables are adjusted down by 7.6dB (the amount above 6dBi for the antenna gain).

U-NII-1 Measurements													
Mode	Channel / Frequency (MHz)		Output 0	Output 1	Output 2	Output 3	Output 4	Output 5	Output 6	Output 7	Total Power (dBm)	15.247 / RSS-247 Limit (dBm)	Margin (dB)
	44	5220	12.25	12.60	12.47	12.39	12.81	12.73	13.26	13.11	21.75	22.4	0.65
	48	5240	12.46	12.96	12.73	12.71	13.05	12.94	13.50	13.36	22.01	22.4	0.39
802.11n (HT20)	36	5180	12.60	13.53	12.84	12.80	12.86	12.97	13.49	13.21	22.08	22.4	0.32
	44	5220	12.59	13.03	12.83	12.86	13.16	13.15	13.63	13.55	22.14	22.4	0.26
	48	5240	12.33	13.12	12.84	12.62	12.90	12.69	13.49	13.16	21.94	22.4	0.46
802.11n (HT40)	38	5190	12.70	13.25	12.60	12.84	12.84	13.03	13.53	13.25	22.05	22.4	0.35
	46	5230	12.42	12.84	12.70	12.55	12.89	12.74	13.34	13.11	21.86	22.4	0.54
802.11ac (VHT80)	42	5210	12.44	13.00	12.59	12.68	13.14	13.14	13.50	13.47	22.04	22.4	0.36

U-NII-2A Measurements													
Mode	Channel / Frequency (MHz)		Output 0	Output 1	Output 2	Output 3	Output 4	Output 5	Output 6	Output 7	Total Power (dBm)	15.247 / RSS-247 Limit (dBm)	Margin (dB)
	60	5300	6.59	7.54	7.51	7.36	6.62	7.12	6.65	6.66	16.06	16.4	0.34
	64	5320	6.46	7.11	5.83	7.30	6.80	6.84	6.75	6.86	15.79	16.4	0.61
802.11n (HT20)	52	5260	6.55	7.34	7.04	6.65	6.83	6.89	7.29	7.36	16.03	16.4	0.37
	60	5300	6.59	7.64	7.45	7.22	6.52	7.06	6.45	6.52	15.98	16.4	0.42
	64	5320	6.50	7.30	6.88	7.06	6.60	6.65	6.57	6.76	15.83	16.4	0.57
802.11n (HT40)	54	5270	6.68	7.31	7.11	7.43	7.01	7.11	7.26	7.21	16.18	16.4	0.22
	62	5310	6.40	7.53	7.29	7.33	6.65	7.14	6.50	6.55	15.97	16.4	0.43
802.11ac (VHT80)	58	5290	6.21	7.22	7.02	7.00	6.21	6.81	6.25	6.31	15.68	16.4	0.72



U-NII-2C Measurements													
Mode	Channel / Frequency (MHz)		Output 0	Output 1	Output 2	Output 3	Output 4	Output 5	Output 6	Output 7	Total Power (dBm)	15.247 / RSS-247 Limit (dBm)	Margin (dB)
	116	5580	6.61	7.30	8.15	8.15	6.22	6.01	5.97	6.19	15.94	16.4	0.46
	140	5700	6.44	6.73	7.45	8.08	5.84	6.00	6.26	6.02	15.70	16.4	0.70
802.11n (HT20)	100	5500	6.63	6.95	7.48	8.22	6.71	6.64	6.56	6.61	16.04	16.4	0.36
	116	5580	6.53	7.14	8.12	8.11	6.09	5.97	5.82	6.11	15.86	16.4	0.54
	140	5700	6.85	7.19	7.91	8.73	6.34	6.42	6.57	6.19	16.14	16.4	0.26
802.11n (HT40)	102	5510	6.51	6.85	7.51	8.11	6.74	6.68	6.60	6.64	16.02	16.4	0.38
	110	5550	6.55	7.20	7.79	8.31	6.60	6.15	6.37	6.71	16.05	16.4	0.35
	134	5670	6.86	7.35	8.09	8.27	6.75	6.40	6.75	6.26	16.18	16.4	0.22
802.11ac (VHT80)	106	5530	6.30	7.04	7.31	8.14	6.76	6.27	6.76	7.09	16.03	16.4	0.37
	138	5690	6.63	6.87	8.07	8.33	5.92	6.08	6.30	5.96	15.90	16.4	0.50

U-NII-3 Measurements													
Mode	Channel / Frequency (MHz)		Output 0	Output 1	Output 2	Output 3	Output 4	Output 5	Output 6	Output 7	Total Power (dBm)	15.247 / RSS-247 Limit (dBm)	Margin (dB)
	157	5785	12.54	12.51	13.93	13.83	11.74	12.20	12.29	12.14	21.75	22.4	0.65
	165	5825	13.15	13.16	14.92	14.62	11.20	11.85	11.14	11.13	21.93	22.4	0.47
802.11n (HT20)	149	5745	12.65	12.66	13.45	13.95	12.08	12.62	12.73	12.77	21.93	22.4	0.47
	157	5785	12.42	12.28	14.03	13.74	11.81	12.19	12.15	11.88	21.67	22.4	0.73
	165	5825	13.03	12.98	15.16	14.49	10.84	11.79	11.06	11.06	21.87	22.4	0.53
802.11n (HT40)	151	5755	12.62	12.67	13.83	13.97	12.12	12.60	12.79	12.61	21.98	22.4	0.42
	159	5795	12.98	12.98	14.59	14.34	12.08	12.37	12.25	12.17	22.10	22.4	0.30
802.11ac (VHT80)	155	5775	12.63	12.69	14.18	14.00	12.36	12.70	12.72	12.76	22.09	22.4	0.31

Test Personnel: <u>Brian Lackey</u>	Test Date: <u>2/21/2022</u>
Supervising/Reviewing Engineer: (Where Applicable) <u>NA</u>	30dBm less 7.6dB (U-NII-1, U-NII-3)
Product Standard: <u>FCC Part 15E</u>	24dBm - 7.6dB (U-NII-2A, U-NII-2C)
Input Voltage: <u>RSS-247 Issue 2</u>	Limit Applied: <u>2C</u>
Pretest Verification w / Ambient Signals or BB Source: <u>120VAC / 60Hz</u>	Ambient Temperature: <u>22.6C</u>
	Relative Humidity: <u>41.2%</u>
	Atmospheric Pressure: <u>991.2mbar</u>

Deviations, Additions, or Exclusions: None

**9 Output Power Data (SISO Operation)**

Since the directional antenna gain is 13.6 dBi the limits in the following tables are adjusted down by 7.6dB (the amount above 6dBi for the antenna gain).

U-NII-1 Measurements (SISO)					
Mode	Channel / Frequency (MHz)		Average Measured Conducted Power (dBm)	Limit (dBm)	Margin (dB)
802.11a	36	5180	22.67	30.00	7.33
	44	5220	22.13	30.00	7.87
	48	5240	21.54	30.00	8.46
802.11n (HT20)	36	5180	22.57	30.00	7.43
	44	5220	22.02	30.00	7.98
	48	5240	21.40	30.00	8.60
802.11n (HT40)	38	5190	22.54	30.00	7.46
	46	5230	21.81	30.00	8.19
802.11ac (VHT80)	42	5210	21.85	30.00	8.15

U-NII-2A Measurements (SISO)					
Mode	Channel / Frequency (MHz)		Average Measured Conducted Power (dBm)	Limit (dBm)	Margin (dB)
802.11a	52	5260	21.90	24.00	2.10
	60	5300	21.99	24.00	2.01
	64	5320	21.36	24.00	2.64
802.11n (HT20)	52	5260	21.75	24.00	2.25
	60	5300	21.90	24.00	2.10
	64	5320	21.90	24.00	2.10
802.11n (HT40)	54	5270	21.96	24.00	2.04
	62	5310	22.32	24.00	1.68
802.11ac (VHT80)	58	5290	22.02	24.00	1.98



U-NII-2C Measurements (SISO)					
Mode	Channel / Frequency (MHz)		Average Measured Conducted Power (dBm)	Limit (dBm)	Margin (dB)
802.11a	100	5500	21.49	24.00	2.51
	116	5580	22.07	24.00	1.93
	140	5700	22.14	24.00	1.86
802.11n (HT20)	100	5500	21.93	24.00	2.07
	116	5580	22.40	24.00	1.60
	140	5700	22.90	24.00	1.10
802.11n (HT40)	102	5510	22.66	24.00	1.34
	110	5550	22.74	24.00	1.26
	134	5670	23.57	24.00	0.43
802.11ac (VHT80)	106	5530	22.05	24.00	1.95
	138	5690	23.64	24.00	0.36

U-NII-3 Measurements (SISO)					
Mode	Channel / Frequency (MHz)		Average Measured Conducted Power (dBm)	Limit (dBm)	Margin (dB)
802.11a	149	5745	22.95	30.00	7.05
	157	5785	23.29	30.00	6.71
	165	5825	24.96	30.00	5.04
802.11n (HT20)	149	5745	22.86	30.00	7.14
	157	5785	23.23	30.00	6.77
	165	5825	24.95	30.00	5.05
802.11n (HT40)	151	5755	22.92	30.00	7.08
	159	5795	23.86	30.00	6.14
802.11ac (VHT80)	155	5775	22.57	30.00	7.43

Test Personnel:	<u>Brian Lackey</u>	Test Date:	<u>2/21/2022</u>
Supervising/Reviewing Engineer:	<u>NA</u>	Limit Applied:	<u>30dBm less 7.6dB (U-NII-1, U-NII-3) 24dBm - 7.6dB (U-NII-2A, U-NII-2C)</u>
(Where Applicable)	<u>FCC Part 15E</u>	Ambient Temperature:	<u>22.6C</u>
Product Standard:	<u>RSS-247 Issue 2</u>	Relative Humidity:	<u>41.2%</u>
Input Voltage:	<u>120VAC / 60Hz</u>	Atmospheric Pressure:	<u>991.2mbar</u>
Pretest Verification w / Ambient Signals or BB Source:	<u>Yes</u>		

Deviations, Additions, or Exclusions: None

**10 Power Spectral Density Data (8x8 MIMO Operation)**

Since the directional antenna gain is 13.6 dBi the limits in the following tables are adjusted down by 7.6dB (the amount above 6dBi for the antenna gain).

U-NII-I Measurements							
TX Mode	Ch. No.	Freq (MHz)	Single Port Measured PSD(dBm)	10log(Nant)	Total Cond. PSD (dBm)	15.407 PSD Limit (dBm)	15.407 Margin (dB)
802.11a	36	5180	0.2	9	9.20	9.40	0.20
	44	5220	-0.66	9	8.34	9.40	1.06
	48	5240	-1.28	9	7.72	9.40	1.68
802.11 (HT20)	36	5180	-0.22	9	8.78	9.40	0.62
	44	5220	-0.87	9	8.13	9.40	1.27
	48	5240	-0.15	9	8.85	9.40	0.55
802.11 (HT40)	38	5190	-5.65	9	3.35	9.40	6.05
	46	5230	-0.41	9	8.59	9.40	0.81
802.11 (VHT80)	42	5210	-3.33	9	5.67	9.40	3.73

U-NII-2A Measurements							
TX Mode	Ch. No.	Freq (MHz)	Single Port Measured PSD (dBm)	10log(Nant)	Total PSD (dBm)	15.407 PSD Limit (dBm)	15.407 Margin (dB)
802.11a	52	5260	-5.79	9	3.21	3.40	0.19
	60	5300	-5.81	9	3.19	3.40	0.21
	64	5320	-5.68	9	3.32	3.40	0.08
802.11 (HT20)	52	5260	-5.97	9	3.03	3.40	0.37
	60	5300	-6.27	9	2.73	3.40	0.67
	64	5320	-6.01	9	2.99	3.40	0.41
802.11 (HT40)	54	5270	-5.87	9	3.13	3.40	0.27
	62	5310	-6.03	9	2.97	3.40	0.43
802.11 (VHT80)	58	5290	-9.97	9	-0.97	3.40	4.37



U-NII-2C Measurements							
TX Mode	Ch. No.	Freq (MHz)	Single Port Measured PSD (dBm)	10log(Nant)	Total PSDr (dBm)	15.407 PSD Limit (dBm)	15.407 Margin (dB)
802.11a	100	5500	-5.84	9	3.16	3.40	0.24
	116	5580	-6.04	9	2.96	3.40	0.44
	140	5700	-5.77	9	3.23	3.40	0.17
802.11 (HT20)	100	5500	-5.88	9	3.12	3.40	0.28
	116	5580	-6.11	9	2.89	3.40	0.51
	140	5700	-5.91	9	3.09	3.40	0.31
802.11 (HT40)	102	5510	-6.6	9	2.40	3.40	1.00
	110	5550	-6.7	9	2.30	3.40	1.10
	134	5670	-6.09	9	2.91	3.40	0.49
802.11 (VHT80)	106	5530	-9.99	9	-0.99	3.40	4.39
	138	5690	-7.16	9	1.84	3.40	1.56

U-NII-3 Measurements							
TX Mode	Ch. No.	Freq (MHz)	Average Measured PSD (dBm)	10log(Nant)	Total PSD (dBm)	15.407 PSD Limit (dBm)	15.407 Margin (dB)
802.11a	149	5745	6.72	9	15.72	22.40	6.68
	157	5785	7.04	9	16.04	22.40	6.36
	165	5825	9.63	9	18.63	22.40	3.77
802.11 (HT20)	149	5745	5.04	9	14.04	22.40	8.36
	157	5785	5.65	9	14.65	22.40	7.75
	165	5825	7.07	9	16.07	22.40	6.33
802.11 (HT40)	151	5755	1.76	9	10.76	22.40	11.64
	159	5795	3.1	9	12.10	22.40	10.30
802.11 (VHT80)	155	5775	-0.51	9	8.49	22.40	13.91

Test Personnel: Bryan TaylorTest Date: 8/16/2021 – 8/17/2021Supervising/Reviewing Engineer:
(Where Applicable)NA17dBm / MHz – 7.6dB (U-NII-1)
11dBm/MHz – 7.6dB (U-NII-2A, U-NII-2C)Limit Applied: 30dBm / 500kHz – 7.6dB (U-NII-3)

FCC Part 15E

Product Standard: RSS-247 Issue 2Input Voltage: 120VAC / 60HzAmbient Temperature: 22.6CRelative Humidity: 41.2%

Pretest Verification w / Ambient

Signals or BB Source: YesAtmospheric Pressure: 991.2mbar

Deviations, Additions, or Exclusions: None

**11 Power Spectral Density Data (SISO Operation)**

Since the directional antenna gain is 13.6 dBi the limits in the following tables are adjusted down by 7.6dB (the amount above 6dBi for the antenna gain).

U-NII-1 Measurements (SISO)					
TX Mode	Ch. No.	Freq (MHz)	Single Port Measured PSD(dBm/MHz)	15.407 PSD Limit (dBm/MHz)	15.407 Margin (dB)
802.11a	36	5180	10.48	17.00	6.52
	44	5220	9.74	17.00	7.26
	48	5240	8.47	17.00	8.53
802.11 (HT20)	36	5180	10.21	17.00	6.79
	44	5220	8.34	17.00	8.66
	48	5240	8.54	17.00	8.46
802.11 (HT40)	38	5190	8.16	17.00	8.84
	46	5230	7.39	17.00	9.61
802.11 (VHT80)	42	5210	4.54	17.00	12.46

U-NII-2A Measurements (SISO)					
TX Mode	Ch. No.	Freq (MHz)	Single Port Measured PSD(dBm/MHz)	15.407 PSD Limit (dBm/MHz)	15.407 Margin (dB)
802.11a	52	5260	10.64	11.00	0.36
	60	5300	10.72	11.00	0.28
	64	5320	10.50	11.00	0.50
802.11 (HT20)	52	5260	10.41	11.00	0.59
	60	5300	10.34	11.00	0.66
	64	5320	10.45	11.00	0.55
802.11 (HT40)	54	5270	7.85	11.00	3.15
	62	5310	8.87	11.00	2.13
802.11 (VHT80)	58	5290	4.98	11.00	6.02

U-NII-2C Measurements (SISO)					
TX Mode	Ch. No.	Freq (MHz)	Single Port Measured PSD(dBm/MHz)	15.407 PSD Limit (dBm/MHz)	15.407 Margin (dB)
802.11a	100	5500	10.86	11.00	0.14
	116	5580	10.81	11.00	0.19
	140	5700	10.37	11.00	0.63
802.11 (HT20)	100	5500	10.94	11.00	0.06
	116	5580	10.83	11.00	0.17
	140	5700	10.91	11.00	0.09
802.11 (HT40)	102	5510	8.61	11.00	2.39
	110	5550	8.86	11.00	2.14
	134	5670	9.86	11.00	1.14
802.11 (VHT80)	106	5530	5.18	11.00	5.82
	138	5690	6.16	11.00	4.84



U-NII-3 Measurements (SISO)					
TX Mode	Ch. No.	Freq (MHz)	Single Port Measured PSD(dBm/500kHz)	15.407 PSD Limit (dBm/500kHz)	15.407 Margin (dB)
802.11a	149	5745	8.40	30.00	21.60
	157	5785	8.87	30.00	21.13
	165	5825	11.14	30.00	18.86
802.11 (HT20)	149	5745	7.82	30.00	22.18
	157	5785	8.59	30.00	21.41
	165	5825	10.55	30.00	19.45
802.11 (HT40)	151	5755	4.83	30.00	25.17
	159	5795	5.52	30.00	24.48
802.11 (VHT80)	155	5775	1.72	30.00	28.28

Test Personnel: Bryan Taylor

Test Date: 8/16/2021 – 8/17/2021

Supervising/Reviewing Engineer: NA
(Where Applicable)

17dBm / MHz – 7.6dB (U-NII-1)
11dBm/MHz – 7.6dB (U-NII-2A, U-NII-2C)

Product Standard: FCC Part 15E

Limit Applied: 30dBm / 500kHz – 7.6dB (U-NII-3)

Input Voltage: RSS-247 Issue 2

Ambient Temperature: 22.6C

Pretest Verification w / Ambient Signals or BB Source: 120VAC / 60Hz

Relative Humidity: 41.2%

Signals or BB Source: Yes

Atmospheric Pressure: 991.2mbar

Deviations, Additions, or Exclusions: None



12 U-NII-1 Radiated Spurious Emissions

12.1 Worst Case Radiated Spurious Emissions Data (802.11a, Channel 36)

Frequency (MHz)	MaxPeak (dBµV/m)	Limit (dBµV/m)	Margin (dB)	Bandwidth (kHz)	Height (cm)	Pol	Azimuth (deg)	Corr. (dB/m)
6250.000000	47.00	88.23	41.23	1000.000	218.0	H	137.0	12
9748.000000	49.95	88.23	38.28	1000.000	181.0	H	131.0	16
10359.500000	53.27	88.23	34.96	1000.000	324.0	V	137.0	18
12338.500000	52.08	73.98	21.90	1000.000	100.0	H	264.0	20
15743.500000	54.24	73.98	19.74	1000.000	410.0	V	275.0	23

Frequency (MHz)	Average (dBµV/m)	Limit (dBµV/m)	Margin (dB)	Bandwidth (kHz)	Height (cm)	Pol	Azimuth (deg)	Corr. (dB/m)
6250.000000	35.60	68.23	32.63	1000.000	218.0	H	137.0	12
9748.000000	37.29	68.23	30.94	1000.000	181.0	H	131.0	16
10359.500000	45.88	68.23	22.35	1000.000	324.0	V	137.0	18
12338.500000	38.78	53.98	15.20	1000.000	100.0	H	264.0	20
15743.500000	40.90	53.98	13.08	1000.000	410.0	V	275.0	23

Test Personnel:	Michael Carlson	Test Date:	6/4/2021 – 6/24/2021
Supervising/Reviewing Engineer:		Limit Applied:	15.407b
(Where Applicable)	NA	Ambient Temperature:	21.5 °C
Product Standard:	FCC Part 15E	Relative Humidity:	40.2 %
Input Voltage:	RSS-247 Issue 2	Atmospheric Pressure:	988.8 mbar
Pretest Verification w / Ambient Signals or BB Source:	120VAC / 60Hz		
	Yes		

Deviations, Additions, or Exclusions: None

**12.2 Worst Case Radiated Spurious Emissions Data (802.11a, Channel 44)**

Frequency (MHz)	QuasiPeak (dB μ V/m)	Limit (dB μ V/m)	Margin (dB)	Bandwidth (kHz)	Height (cm)	Pol	Azimuth (deg)	Corr. (dB/m)
125.006111	37.78	43.52	5.75	120.000	103.0	V	0.0	22
256.117778	38.52	46.02	7.50	120.000	100.0	H	68.0	22
256.548889	37.92	46.02	8.10	120.000	100.0	H	79.0	22
257.303333	37.23	46.02	8.80	120.000	100.0	H	102.0	22
257.896111	37.14	46.02	8.88	120.000	103.0	H	100.0	22
258.273333	35.58	46.02	10.45	120.000	106.0	H	109.0	22
267.218889	39.80	46.02	6.22	120.000	103.0	H	214.0	23
273.901111	34.00	46.02	12.03	120.000	149.0	V	264.0	23
274.601667	34.34	46.02	11.69	120.000	162.0	V	268.0	23
400.593889	32.58	46.02	13.44	120.000	100.0	H	48.0	27

Frequency (MHz)	MaxPeak (dB μ V/m)	Limit (dB μ V/m)	Margin (dB)	Bandwidth (kHz)	Height (cm)	Pol	Azimuth (deg)	Corr. (dB/m)
9748.000000	49.17	88.23	39.06	1000.000	307.0	H	114.0	16
10439.500000	52.84	88.23	35.39	1000.000	279.0	H	114.0	17
12361.000000	52.60	73.98	21.38	1000.000	117.0	H	183.0	21
14622.000000	55.39	88.23	32.84	1000.000	256.0	H	65.0	21
19001.500000	56.25	73.98	17.73	1000.000	100.0	H	67.0	19
23739.500000	57.66	73.98	16.32	1000.000	385.0	V	300.0	11
31406.000000	62.30	73.98	11.68	1000.000	410.0	V	288.0	17
31634.500000	61.74	73.98	12.24	1000.000	391.0	V	272.0	17
36439.000000	64.97	73.98	9.01	1000.000	410.0	H	0.0	19
36467.000000	64.22	73.98	9.76	1000.000	100.0	H	164.0	19

Frequency (MHz)	Average (dB μ V/m)	Limit (dB μ V/m)	Margin (dB)	Bandwidth (kHz)	Height (cm)	Pol	Azimuth (deg)	Corr. (dB/m)
9748.000000	37.07	68.23	31.16	1000.000	307.0	H	114.0	16
10439.500000	43.70	68.23	24.53	1000.000	279.0	H	114.0	17
12361.000000	38.93	53.98	15.05	1000.000	117.0	H	183.0	21
14622.000000	45.50	68.23	22.73	1000.000	256.0	H	65.0	21
19001.500000	43.09	53.98	10.89	1000.000	100.0	H	67.0	19
23739.500000	44.36	53.98	9.62	1000.000	385.0	V	300.0	11
31406.000000	48.45	53.98	5.53	1000.000	410.0	V	288.0	17
31634.500000	48.73	53.98	5.25	1000.000	391.0	V	272.0	17
36439.000000	51.37	53.98	2.61	1000.000	410.0	H	0.0	19
36467.000000	51.09	53.98	2.89	1000.000	100.0	H	164.0	19

Test Personnel: Michael Carlson
Supervising/Reviewing Engineer: NA
(Where Applicable) FCC Part 15E
Product Standard: RSS-247 Issue 2
Input Voltage: 120VAC / 60Hz
Pretest Verification w / Ambient Signals or BB Source: Yes

Test Date: 6/4/2021 – 6/24/2021
Limit Applied: 15.407b
Ambient Temperature: 21.5 °C
Relative Humidity: 40.2 %
Atmospheric Pressure: 988.8 mbar

Deviations, Additions, or Exclusions: None

**12.3 Worst Case Radiated Spurious Emissions Data (802.11a, Channel 48)**

Frequency (MHz)	MaxPeak (dBμV/m)	Limit (dBμV/m)	Margin (dB)	Bandwidth (kHz)	Height (cm)	Pol	Azimuth (deg)	Corr. (dB/m)
6250.000000	47.58	88.23	40.65	1000.000	200.0	V	137.0	12
9748.000000	48.78	88.23	39.45	1000.000	280.0	V	108.0	16
10479.500000	52.33	88.23	35.90	1000.000	271.0	V	114.0	18
14622.000000	53.96	88.23	34.27	1000.000	289.0	V	102.0	21
16014.000000	54.55	73.98	19.43	1000.000	109.0	H	0.0	24

Frequency (MHz)	Average (dBμV/m)	Limit (dBμV/m)	Margin (dB)	Bandwidth (kHz)	Height (cm)	Pol	Azimuth (deg)	Corr. (dB/m)
6250.000000	36.08	68.23	32.15	1000.000	200.0	V	137.0	12
9748.000000	36.31	68.23	31.92	1000.000	280.0	V	108.0	16
10479.500000	42.75	68.23	25.48	1000.000	271.0	V	114.0	18
14622.000000	42.82	68.23	25.41	1000.000	289.0	V	102.0	21
16014.000000	41.36	53.98	12.62	1000.000	109.0	H	0.0	24

Test Personnel: Michael Carlson
Supervising/Reviewing Engineer: _____
(Where Applicable) NA
FCC Part 15E
Product Standard: RSS-247 Issue 2
Input Voltage: 120VAC / 60Hz
Pretest Verification w / Ambient
Signals or BB Source: Yes

Test Date: 6/4/2021 – 6/24/2021
Limit Applied: 15.407b
Ambient Temperature: 21.5 °C
Relative Humidity: 40.2 %
Atmospheric Pressure: 988.8 mbar

Deviations, Additions, or Exclusions: None

**12.4 Worst Case Radiated Spurious Emissions Data (802.11n, Channel 36)**

Frequency (MHz)	MaxPeak (dBμV/m)	Limit (dBμV/m)	Margin (dB)	Bandwidth (kHz)	Height (cm)	Pol	Azimuth (deg)	Corr. (dB/m)
9648.000000	51.74	88.23	36.49	1000.000	325.0	V	302.0	17
10359.500000	51.27	88.23	36.96	1000.000	410.0	V	230.0	18
14472.000000	53.36	73.98	20.62	1000.000	311.0	V	246.0	21

Frequency (MHz)	Average (dBμV/m)	Limit (dBμV/m)	Margin (dB)	Bandwidth (kHz)	Height (cm)	Pol	Azimuth (deg)	Corr. (dB/m)
9648.000000	42.89	68.23	25.34	1000.000	325.0	V	302.0	17
10359.500000	41.33	68.23	26.90	1000.000	410.0	V	230.0	18
14472.000000	40.97	53.98	13.01	1000.000	311.0	V	246.0	21

Test Personnel:	<u>Michael Carlson</u>	Test Date:	<u>6/4/2021 – 6/24/2021</u>
Supervising/Reviewing Engineer:	<u>NA</u>	Limit Applied:	<u>15.407b</u>
(Where Applicable)	<u>FCC Part 15E</u>	Ambient Temperature:	<u>21.5 °C</u>
Product Standard:	<u>RSS-247 Issue 2</u>	Relative Humidity:	<u>40.2 %</u>
Input Voltage:	<u>120VAC / 60Hz</u>	Atmospheric Pressure:	<u>988.8 mbar</u>
Pretest Verification w / Ambient Signals or BB Source:	<u>Yes</u>		

Deviations, Additions, or Exclusions: None

**12.5 Worst Case Radiated Spurious Emissions Data (802.11n, Channel 44)**

Frequency (MHz)	QuasiPeak (dB μ V/m)	Limit (dB μ V/m)	Margin (dB)	Bandwidth (kHz)	Height (cm)	Pol	Azimuth (deg)	Corr. (dB/m)
125.006111	37.78	43.52	5.75	120.000	103.0	V	0.0	22
256.117778	38.52	46.02	7.50	120.000	100.0	H	68.0	22
256.548889	37.92	46.02	8.10	120.000	100.0	H	79.0	22
257.303333	37.23	46.02	8.80	120.000	100.0	H	102.0	22
257.896111	37.14	46.02	8.88	120.000	103.0	H	100.0	22
258.273333	35.58	46.02	10.45	120.000	106.0	H	109.0	22
267.218889	39.80	46.02	6.22	120.000	103.0	H	214.0	23
273.901111	34.00	46.02	12.03	120.000	149.0	V	264.0	23
274.601667	34.34	46.02	11.69	120.000	162.0	V	268.0	23
400.593889	32.58	46.02	13.44	120.000	100.0	H	48.0	27

Frequency (MHz)	MaxPeak (dB μ V/m)	Limit (dB μ V/m)	Margin (dB)	Bandwidth (kHz)	Height (cm)	Pol	Azimuth (deg)	Corr. (dB/m)
9648.000000	51.35	88.23	36.88	1000.000	326.0	V	300.0	17
10439.500000	51.10	88.23	37.13	1000.000	410.0	V	233.0	17
14472.000000	54.69	73.98	19.29	1000.000	142.0	V	244.0	21
19561.500000	57.13	73.98	16.85	1000.000	410.0	V	200.0	16
22843.500000	58.07	73.98	15.91	1000.000	410.0	H	337.0	10
23909.000000	59.63	73.98	14.35	1000.000	324.0	H	238.0	11
31727.000000	61.68	73.98	12.30	1000.000	410.0	H	0.0	17
36453.000000	65.18	73.98	8.80	1000.000	100.0	H	127.0	19

Frequency (MHz)	Average (dB μ V/m)	Limit (dB μ V/m)	Margin (dB)	Bandwidth (kHz)	Height (cm)	Pol	Azimuth (deg)	Corr. (dB/m)
9648.000000	41.54	68.23	26.69	1000.000	326.0	V	300.0	17
10439.500000	40.81	68.23	27.42	1000.000	410.0	V	233.0	17
14472.000000	43.42	53.98	10.56	1000.000	142.0	V	244.0	21
19561.500000	43.59	53.98	10.39	1000.000	410.0	V	200.0	16
22843.500000	45.13	53.98	8.85	1000.000	410.0	H	337.0	10
23909.000000	45.84	53.98	8.14	1000.000	324.0	H	238.0	11
31727.000000	48.38	53.98	5.60	1000.000	410.0	H	0.0	17
36453.000000	51.93	53.98	2.05	1000.000	100.0	H	127.0	19

Test Personnel:	<u>Michael Carlson</u>	Test Date:	<u>6/4/2021 – 6/24/2021</u>
Supervising/Reviewing Engineer:	<u>NA</u>	Limit Applied:	<u>15.407b</u>
(Where Applicable)	<u>FCC Part 15E</u>	Ambient Temperature:	<u>21.5 °C</u>
Product Standard:	<u>RSS-247 Issue 2</u>	Relative Humidity:	<u>40.2 %</u>
Input Voltage:	<u>120VAC / 60Hz</u>	Atmospheric Pressure:	<u>988.8 mbar</u>
Pretest Verification w / Ambient Signals or BB Source:	<u>Yes</u>		

Deviations, Additions, or Exclusions: None

**12.6 Worst Case Radiated Spurious Emissions Data (802.11n, Channel 48)**

Frequency (MHz)	MaxPeak (dBμV/m)	Limit (dBμV/m)	Margin (dB)	Bandwidth (kHz)	Height (cm)	Pol	Azimuth (deg)	Corr. (dB/m)
9648.000000	51.29	88.23	36.94	1000.000	410.0	V	287.0	17
10480.000000	54.06	88.23	34.17	1000.000	297.0	V	272.0	18
14472.000000	54.59	73.98	19.39	1000.000	134.0	V	243.0	21

Frequency (MHz)	Average (dBμV/m)	Limit (dBμV/m)	Margin (dB)	Bandwidth (kHz)	Height (cm)	Pol	Azimuth (deg)	Corr. (dB/m)
9648.000000	41.40	68.23	26.83	1000.000	410.0	V	287.0	17
10480.000000	46.95	68.23	21.28	1000.000	297.0	V	272.0	18
14472.000000	42.06	53.98	11.92	1000.000	134.0	V	243.0	21

Test Personnel:	<u>Michael Carlson</u>	Test Date:	<u>6/4/2021 – 6/24/2021</u>
Supervising/Reviewing Engineer:	<u>NA</u>	Limit Applied:	<u>15.407b</u>
(Where Applicable)	<u>FCC Part 15E</u>	Ambient Temperature:	<u>21.5 °C</u>
Product Standard:	<u>RSS-247 Issue 2</u>	Relative Humidity:	<u>40.2 %</u>
Input Voltage:	<u>120VAC / 60Hz</u>	Atmospheric Pressure:	<u>988.8 mbar</u>
Pretest Verification w / Ambient Signals or BB Source:	<u>Yes</u>		

Deviations, Additions, or Exclusions: None



12.7 Worst Case Radiated Spurious Emissions Data (802.11n (40MHz), Channel 38)

Frequency (MHz)	MaxPeak (dBµV/m)	Limit (dBµV/m)	Margin (dB)	Bandwidth (kHz)	Height (cm)	Pol	Azimuth (deg)	Corr. (dB/m)
9648.000000	49.78	88.23	38.45	1000.000	410.0	V	282.0	17
10380.000000	51.99	88.23	36.24	1000.000	410.0	V	229.0	17
14472.000000	53.71	73.98	20.27	1000.000	126.0	V	242.0	21

Frequency (MHz)	Average (dBµV/m)	Limit (dBµV/m)	Margin (dB)	Bandwidth (kHz)	Height (cm)	Pol	Azimuth (deg)	Corr. (dB/m)
9648.000000	38.77	68.23	29.46	1000.000	410.0	V	282.0	17
10380.000000	41.83	68.23	26.40	1000.000	410.0	V	229.0	17
14472.000000	42.20	53.98	11.78	1000.000	126.0	V	242.0	21

Test Personnel:	<u>Michael Carlson</u>	Test Date:	<u>6/4/2021 – 6/24/2021</u>
Supervising/Reviewing Engineer:	<u>NA</u>	Limit Applied:	<u>15.407b</u>
(Where Applicable)	<u>FCC Part 15E</u>	Ambient Temperature:	<u>21.5 °C</u>
Product Standard:	<u>RSS-247 Issue 2</u>	Relative Humidity:	<u>40.2 %</u>
Input Voltage:	<u>120VAC / 60Hz</u>	Atmospheric Pressure:	<u>988.8 mbar</u>
Pretest Verification w / Ambient Signals or BB Source:	<u>Yes</u>		

Deviations, Additions, or Exclusions: None

**12.8 Worst Case Radiated Spurious Emissions Data (802.11n (40MHz), Channel 46)**

Frequency (MHz)	QuasiPeak (dB μ V/m)	Limit (dB μ V/m)	Margin (dB)	Bandwidth (kHz)	Height (cm)	Pol	Azimuth (deg)	Corr. (dB/m)
125.006111	37.73	43.52	5.79	120.000	101.0	V	0.0	22
256.225556	37.93	46.02	8.09	120.000	103.0	H	90.0	22
270.344444	39.92	46.02	6.10	120.000	101.0	V	164.0	23
274.224444	36.68	46.02	9.34	120.000	103.0	H	203.0	23
400.001111	35.90	46.02	10.12	120.000	209.0	H	174.0	27
400.701667	34.79	46.02	11.23	120.000	207.0	H	183.0	27

Frequency (MHz)	MaxPeak (dB μ V/m)	Limit (dB μ V/m)	Margin (dB)	Bandwidth (kHz)	Height (cm)	Pol	Azimuth (deg)	Corr. (dB/m)
9648.000000	51.70	88.23	36.53	1000.000	318.0	V	300.0	17
10460.000000	55.12	88.23	33.11	1000.000	320.0	V	284.0	18
14472.000000	53.79	73.98	20.19	1000.000	126.0	V	242.0	21
23920.000000	58.99	73.98	14.99	1000.000	100.0	H	296.0	11
31740.000000	61.94	73.98	12.04	1000.000	410.0	H	246.0	17
36472.000000	65.72	73.98	8.26	1000.000	100.0	H	67.0	19

Frequency (MHz)	Average (dB μ V/m)	Limit (dB μ V/m)	Margin (dB)	Bandwidth (kHz)	Height (cm)	Pol	Azimuth (deg)	Corr. (dB/m)
9648.000000	40.86	68.23	27.37	1000.000	318.0	V	300.0	17
10460.000000	49.79	68.23	18.44	1000.000	320.0	V	284.0	18
14472.000000	41.87	53.98	12.11	1000.000	126.0	V	242.0	21
23920.000000	45.91	53.98	8.07	1000.000	100.0	H	296.0	11
31740.000000	48.25	53.98	5.73	1000.000	410.0	H	246.0	17
36472.000000	51.91	53.98	2.05	1000.000	100.0	H	67.0	19

Test Personnel:	<u>Michael Carlson</u>	Test Date:	<u>6/4/2021 – 6/24/2021</u>
Supervising/Reviewing Engineer: (Where Applicable)	<u>NA</u>	Limit Applied:	<u>15.407b</u>
Product Standard:	<u>FCC Part 15E</u>	Ambient Temperature:	<u>21.5 °C</u>
Input Voltage:	<u>RSS-247 Issue 2</u>	Relative Humidity:	<u>40.2 %</u>
Pretest Verification w / Ambient Signals or BB Source:	<u>120VAC / 60Hz</u>	Atmospheric Pressure:	<u>988.8 mbar</u>
	<u>Yes</u>		

Deviations, Additions, or Exclusions: None

**12.9 Worst Case Radiated Spurious Emissions Data (802.11n (80MHz), Channel 42)**

Frequency (MHz)	QuasiPeak (dB μ V/m)	Limit (dB μ V/m)	Margin (dB)	Bandwidth (kHz)	Height (cm)	Pol	Azimuth (deg)	Corr. (dB/m)
113.851111	29.74	43.52	13.78	120.000	100.0	V	186.0	21
125.006111	37.95	43.52	5.57	120.000	100.0	V	0.0	22
255.794444	36.75	46.02	9.27	120.000	103.0	H	68.0	22
269.913333	39.83	46.02	6.19	120.000	100.0	V	159.0	23
400.593889	35.55	46.02	10.47	120.000	178.0	H	162.0	27

Frequency (MHz)	MaxPeak (dB μ V/m)	Limit (dB μ V/m)	Margin (dB)	Bandwidth (kHz)	Height (cm)	Pol	Azimuth (deg)	Corr. (dB/m)
9648.500000	49.57	88.23	38.66	1000.000	328.0	V	292.0	17
10420.000000	56.13	88.23	32.10	1000.000	410.0	V	238.0	17
14472.000000	54.64	73.98	19.34	1000.000	135.0	V	244.0	21
21063.000000	55.53	73.98	18.45	1000.000	388.0	V	348.0	13
22686.500000	56.64	73.98	17.34	1000.000	383.0	H	201.0	11
23721.500000	57.89	73.98	16.09	1000.000	389.0	H	43.0	11
31456.000000	62.45	73.98	11.53	1000.000	100.0	H	304.0	17
36418.500000	65.00	88.23	23.23	1000.000	410.0	H	0.0	19

Frequency (MHz)	Average (dB μ V/m)	Limit (dB μ V/m)	Margin (dB)	Bandwidth (kHz)	Height (cm)	Pol	Azimuth (deg)	Corr. (dB/m)
9648.500000	37.08	68.23	31.15	1000.000	328.0	V	292.0	17
10420.000000	51.54	68.23	16.69	1000.000	410.0	V	238.0	17
14472.000000	43.10	53.98	10.88	1000.000	135.0	V	244.0	21
21063.000000	42.47	53.98	11.51	1000.000	388.0	V	348.0	13
22686.500000	43.15	53.98	10.83	1000.000	383.0	H	201.0	11
23721.500000	44.81	53.98	9.17	1000.000	389.0	H	43.0	11
31456.000000	48.95	53.98	5.03	1000.000	100.0	H	304.0	17
36418.500000	51.23	68.23	17.00	1000.000	410.0	H	0.0	19

Test Personnel:	Michael Carlson	Test Date:	6/4/2021 – 6/24/2021
Supervising/Reviewing Engineer:	NA	Limit Applied:	15.407b
(Where Applicable)	FCC Part 15E	Ambient Temperature:	21.5 °C
Product Standard:	RSS-247 Issue 2	Relative Humidity:	40.2 %
Input Voltage:	120VAC / 60Hz	Atmospheric Pressure:	988.8 mbar
Pretest Verification w / Ambient Signals or BB Source:	Yes		

Deviations, Additions, or Exclusions: None



13 U-NII-2A Radiated Spurious Emissions

13.1 Worst Case Radiated Spurious Emissions Data (802.11a, Channel 52)

Frequency (MHz)	MaxPeak (dBµV/m)	Limit (dBµV/m)	Margin (dB)	Bandwidth (kHz)	Height (cm)	Pol	Azimuth (deg)	Corr. (dB/m)
5250.000000	54.71	88.23	33.52	1000.000	374.0	H	56.0	10
5841.500000	50.26	88.23	37.97	1000.000	410.0	H	46.0	12
9648.000000	50.51	88.23	37.72	1000.000	410.0	V	283.0	17
10520.000000	54.92	88.23	33.31	1000.000	316.0	V	281.0	18
14472.000000	54.63	73.98	19.35	1000.000	132.0	V	244.0	21

Frequency (MHz)	Average (dBµV/m)	Limit (dBµV/m)	Margin (dB)	Bandwidth (kHz)	Height (cm)	Pol	Azimuth (deg)	Corr. (dB/m)
5250.000000	43.02	68.23	25.21	1000.000	374.0	H	56.0	10
5841.500000	36.88	68.23	31.35	1000.000	410.0	H	46.0	12
9648.000000	39.61	68.23	28.62	1000.000	410.0	V	283.0	17
10520.000000	48.92	68.23	19.31	1000.000	316.0	V	281.0	18
14472.000000	43.87	53.98	10.11	1000.000	132.0	V	244.0	21

Test Personnel:	<u>Michael Carlson</u>	Test Date:	<u>6/4/2021 – 6/24/2021</u>
Supervising/Reviewing Engineer:	<u>NA</u>	Limit Applied:	<u>15.407b</u>
(Where Applicable)	<u>FCC Part 15E</u>	Ambient Temperature:	<u>21.5 °C</u>
Product Standard:	<u>RSS-247 Issue 2</u>	Relative Humidity:	<u>40.2 %</u>
Input Voltage:	<u>120VAC / 60Hz</u>	Atmospheric Pressure:	<u>988.8 mbar</u>
Pretest Verification w / Ambient Signals or BB Source:	<u>Yes</u>		

Deviations, Additions, or Exclusions: None

**13.2 Worst Case Radiated Spurious Emissions Data (802.11a, Channel 60)**

Frequency (MHz)	QuasiPeak (dBµV/m)	Limit (dBµV/m)	Margin (dB)	Bandwidth (kHz)	Height (cm)	Pol	Azimuth (deg)	Corr. (dB/m)
125.006111	37.96	43.52	5.56	120.000	100.0	V	0.0	22
256.063889	37.63	46.02	8.39	120.000	100.0	H	78.0	22
257.303333	37.66	46.02	8.36	120.000	102.0	H	91.0	22
257.896111	37.58	46.02	8.44	120.000	106.0	H	99.0	22
270.506111	38.47	46.02	7.55	120.000	321.0	H	267.0	23
273.955000	35.86	46.02	10.16	120.000	163.0	V	265.0	23
275.032778	33.08	46.02	12.94	120.000	161.0	V	265.0	23

Frequency (MHz)	MaxPeak (dBµV/m)	Limit (dBµV/m)	Margin (dB)	Bandwidth (kHz)	Height (cm)	Pol	Azimuth (deg)	Corr. (dB/m)
5841.500000	49.85	88.23	38.38	1000.000	410.0	H	44.0	12
9648.000000	50.44	88.23	37.79	1000.000	292.0	V	295.0	17
10600.000000	52.25	73.98	21.73	1000.000	321.0	V	281.0	18
14472.000000	54.95	73.98	19.03	1000.000	125.0	V	244.0	21
19399.000000	58.29	73.98	15.69	1000.000	140.0	H	0.0	17
22549.000000	57.77	73.98	16.21	1000.000	100.0	H	0.0	11
23758.500000	60.14	73.98	13.84	1000.000	341.0	H	214.0	11
31456.500000	61.64	73.98	12.34	1000.000	162.0	H	330.0	17
36442.000000	64.94	73.98	9.04	1000.000	100.0	H	257.0	19

Frequency (MHz)	Average (dBµV/m)	Limit (dBµV/m)	Margin (dB)	Bandwidth (kHz)	Height (cm)	Pol	Azimuth (deg)	Corr. (dB/m)
5841.500000	36.21	68.23	32.02	1000.000	410.0	H	44.0	12
9648.000000	38.54	68.23	29.69	1000.000	292.0	V	295.0	17
10600.000000	44.00	53.98	9.98	1000.000	321.0	V	281.0	18
14472.000000	43.76	53.98	10.22	1000.000	125.0	V	244.0	21
19399.000000	44.21	53.98	9.77	1000.000	140.0	H	0.0	17
22549.000000	44.40	53.98	9.58	1000.000	100.0	H	0.0	11
23758.500000	46.19	53.98	7.79	1000.000	341.0	H	214.0	11
31456.500000	48.52	53.98	5.46	1000.000	162.0	H	330.0	17
36442.000000	51.90	53.98	2.08	1000.000	100.0	H	257.0	19

Test Personnel: Michael Carlson
Supervising/Reviewing Engineer: NA
(Where Applicable) FCC Part 15E
Product Standard: RSS-247 Issue 2
Input Voltage: 120VAC / 60Hz
Pretest Verification w / Ambient Signals or BB Source: Yes

Test Date: 6/4/2021 – 6/24/2021
Limit Applied: 15.407b
Ambient Temperature: 21.5 °C
Relative Humidity: 40.2 %
Atmospheric Pressure: 988.8 mbar

Deviations, Additions, or Exclusions: None

**13.3 Worst Case Radiated Spurious Emissions Data (802.11a, Channel 64)**

Frequency (MHz)	MaxPeak (dB μ V/m)	Limit (dB μ V/m)	Margin (dB)	Bandwidth (kHz)	Height (cm)	Pol	Azimuth (deg)	Corr. (dB/m)
5832.500000	50.25	88.23	37.98	1000.000	410.0	H	44.0	12
9648.000000	51.50	88.23	36.73	1000.000	364.0	V	304.0	17
10640.000000	53.35	73.98	20.63	1000.000	309.0	V	284.0	18
14472.000000	55.62	73.98	18.36	1000.000	135.0	V	246.0	21

Frequency (MHz)	Average (dB μ V/m)	Limit (dB μ V/m)	Margin (dB)	Bandwidth (kHz)	Height (cm)	Pol	Azimuth (deg)	Corr. (dB/m)
5832.500000	36.24	68.23	31.99	1000.000	410.0	H	44.0	12
9648.000000	41.61	68.23	26.62	1000.000	364.0	V	304.0	17
10640.000000	45.65	53.98	8.33	1000.000	309.0	V	284.0	18
14472.000000	44.91	53.98	9.07	1000.000	135.0	V	246.0	21

Test Personnel: Michael Carlson
Supervising/Reviewing Engineer: _____
(Where Applicable) NA
FCC Part 15E
Product Standard: RSS-247 Issue 2
Input Voltage: 120VAC / 60Hz
Pretest Verification w / Ambient
Signals or BB Source: Yes

Test Date: 6/4/2021 – 6/24/2021
Limit Applied: 15.407b
Ambient Temperature: 21.5 °C
Relative Humidity: 40.2 %
Atmospheric Pressure: 988.8 mbar

Deviations, Additions, or Exclusions: None



13.4 Worst Case Radiated Spurious Emissions Data (802.11n, Channel 52)

Frequency (MHz)	MaxPeak (dBµV/m)	Limit (dBµV/m)	Margin (dB)	Bandwidth (kHz)	Height (cm)	Pol	Azimuth (deg)	Corr. (dB/m)
5815.000000	51.54	88.23	36.69	1000.000	410.0	H	56.0	12
9648.000000	50.70	88.23	37.53	1000.000	299.0	V	295.0	17
10519.500000	53.76	88.23	34.47	1000.000	325.0	V	239.0	18
14472.000000	54.06	73.98	19.92	1000.000	143.0	V	241.0	21

Frequency (MHz)	Average (dBµV/m)	Limit (dBµV/m)	Margin (dB)	Bandwidth (kHz)	Height (cm)	Pol	Azimuth (deg)	Corr. (dB/m)
5815.000000	37.86	68.23	30.37	1000.000	410.0	H	56.0	12
9648.000000	39.23	68.23	29.00	1000.000	299.0	V	295.0	17
10519.500000	44.48	68.23	23.75	1000.000	325.0	V	239.0	18
14472.000000	42.03	53.98	11.95	1000.000	143.0	V	241.0	21

Test Personnel: Michael Carlson
Supervising/Reviewing Engineer: NA
(Where Applicable) FCC Part 15E
Product Standard: RSS-247 Issue 2
Input Voltage: 120VAC / 60Hz
Pretest Verification w / Ambient Signals or BB Source: Yes

Test Date: 6/4/2021 – 6/24/2021
Limit Applied: 15.407b
Ambient Temperature: 21.5 °C
Relative Humidity: 40.2 %
Atmospheric Pressure: 988.8 mbar

Deviations, Additions, or Exclusions: None

**13.5 Worst Case Radiated Spurious Emissions Data (802.11n, Channel 60)**

Frequency (MHz)	QuasiPeak (dBµV/m)	Limit (dBµV/m)	Margin (dB)	Bandwidth (kHz)	Height (cm)	Pol	Azimuth (deg)	Corr. (dB/m)
37.544444	26.77	40.00	13.23	120.000	104.0	V	88.0	22
113.689444	32.10	43.52	11.42	120.000	103.0	V	161.0	21
125.006111	37.19	43.52	6.33	120.000	104.0	V	8.0	22
259.620556	33.68	46.02	12.34	120.000	103.0	V	46.0	22
269.536111	40.96	46.02	5.06	120.000	191.0	V	173.0	23
270.613889	41.51	46.02	4.51	120.000	206.0	V	173.0	23
608.012222	31.83	46.02	14.20	120.000	104.0	H	255.0	32

Frequency (MHz)	MaxPeak (dBµV/m)	Limit (dBµV/m)	Margin (dB)	Bandwidth (kHz)	Height (cm)	Pol	Azimuth (deg)	Corr. (dB/m)
5839.000000	50.64	88.23	37.59	1000.000	410.0	H	56.0	12
10599.500000	52.13	88.23	36.10	1000.000	326.0	V	278.0	18
14472.000000	55.08	73.98	18.90	1000.000	125.0	V	248.0	21
20079.000000	56.15	73.98	17.83	1000.000	387.0	H	34.0	15
23745.500000	58.08	73.98	15.90	1000.000	410.0	H	311.0	11
31540.500000	62.30	73.98	11.68	1000.000	109.0	H	69.0	17
36446.500000	64.75	73.98	9.23	1000.000	410.0	H	258.0	19
36462.000000	64.75	73.98	9.23	1000.000	109.0	H	280.0	19
36475.500000	64.91	73.98	9.07	1000.000	109.0	V	0.0	19

Frequency (MHz)	Average (dBµV/m)	Limit (dBµV/m)	Margin (dB)	Bandwidth (kHz)	Height (cm)	Pol	Azimuth (deg)	Corr. (dB/m)
5839.000000	36.60	68.23	31.63	1000.000	410.0	H	56.0	12
10599.500000	42.98	68.23	25.25	1000.000	326.0	V	278.0	18
14472.000000	45.67	53.98	8.31	1000.000	125.0	V	248.0	21
20079.000000	42.71	53.98	11.27	1000.000	387.0	H	34.0	15
23745.500000	44.59	53.98	9.39	1000.000	410.0	H	311.0	11
31540.500000	49.18	53.98	4.80	1000.000	109.0	H	69.0	17
36446.500000	51.41	53.98	2.57	1000.000	410.0	H	258.0	19
36462.000000	51.36	53.98	2.62	1000.000	109.0	H	280.0	19
36475.500000	50.94	53.98	3.04	1000.000	109.0	V	0.0	19

Test Personnel: Michael Carlson
Supervising/Reviewing Engineer: NA
(Where Applicable) FCC Part 15E
Product Standard: RSS-247 Issue 2
Input Voltage: 120VAC / 60Hz
Pretest Verification w / Ambient Signals or BB Source: Yes

Test Date: 6/4/2021 – 6/24/2021
Limit Applied: 15.407b
Ambient Temperature: 21.5 °C
Relative Humidity: 40.2 %
Atmospheric Pressure: 988.8 mbar

Deviations, Additions, or Exclusions: None



13.6 Worst Case Radiated Spurious Emissions Data (802.11n, Channel 64)

Frequency (MHz)	MaxPeak (dBµV/m)	Limit (dBµV/m)	Margin (dB)	Bandwidth (kHz)	Height (cm)	Pol	Azimuth (deg)	Corr. (dB/m)
5766.000000	49.38	88.23	38.85	1000.000	395.0	H	44.0	11
9648.000000	50.42	88.23	37.81	1000.000	410.0	V	283.0	17
10640.000000	54.76	73.98	19.22	1000.000	410.0	V	252.0	18
14472.000000	54.12	73.98	19.86	1000.000	257.0	V	246.0	21

Frequency (MHz)	Average (dBµV/m)	Limit (dBµV/m)	Margin (dB)	Bandwidth (kHz)	Height (cm)	Pol	Azimuth (deg)	Corr. (dB/m)
5766.000000	35.90	68.23	32.33	1000.000	395.0	H	44.0	11
9648.000000	39.58	68.23	28.65	1000.000	410.0	V	283.0	17
10640.000000	47.40	53.98	6.58	1000.000	410.0	V	252.0	18
14472.000000	41.52	53.98	12.46	1000.000	257.0	V	246.0	21

Test Personnel:	<u>Michael Carlson</u>	Test Date:	<u>6/4/2021 – 6/24/2021</u>
Supervising/Reviewing Engineer:	<u>NA</u>	Limit Applied:	<u>15.407b</u>
(Where Applicable)	<u>FCC Part 15E</u>	Ambient Temperature:	<u>21.5 °C</u>
Product Standard:	<u>RSS-247 Issue 2</u>	Relative Humidity:	<u>40.2 %</u>
Input Voltage:	<u>120VAC / 60Hz</u>	Atmospheric Pressure:	<u>988.8 mbar</u>
Pretest Verification w / Ambient Signals or BB Source:	<u>Yes</u>		

Deviations, Additions, or Exclusions: None



13.7 Worst Case Radiated Spurious Emissions Data (802.11n (40MHz), Channel 54)

Frequency (MHz)	MaxPeak (dBµV/m)	Limit (dBµV/m)	Margin (dB)	Bandwidth (kHz)	Height (cm)	Pol	Azimuth (deg)	Corr. (dB/m)
5815.000000	51.54	88.23	36.69	1000.000	410.0	H	56.0	12
9648.000000	50.70	88.23	37.53	1000.000	299.0	V	295.0	17
10519.500000	53.76	88.23	34.47	1000.000	325.0	V	239.0	18
14472.000000	54.06	73.98	19.92	1000.000	143.0	V	241.0	21

Frequency (MHz)	Average (dBµV/m)	Limit (dBµV/m)	Margin (dB)	Bandwidth (kHz)	Height (cm)	Pol	Azimuth (deg)	Corr. (dB/m)
5815.000000	37.86	68.23	30.37	1000.000	410.0	H	56.0	12
9648.000000	39.23	68.23	29.00	1000.000	299.0	V	295.0	17
10519.500000	44.48	68.23	23.75	1000.000	325.0	V	239.0	18
14472.000000	42.03	53.98	11.95	1000.000	143.0	V	241.0	21

Test Personnel: Michael Carlson
Supervising/Reviewing Engineer: _____
(Where Applicable) NA
FCC Part 15E
Product Standard: RSS-247 Issue 2
Input Voltage: 120VAC / 60Hz
Pretest Verification w / Ambient
Signals or BB Source: Yes

Test Date: 6/4/2021 – 6/24/2021
Limit Applied: 15.407b
Ambient Temperature: 21.5 °C
Relative Humidity: 40.2 %
Atmospheric Pressure: 988.8 mbar

Deviations, Additions, or Exclusions: None

**13.8 Worst Case Radiated Spurious Emissions Data (802.11n (40MHz), Channel 62)**

Frequency (MHz)	QuasiPeak (dB μ V/m)	Limit (dB μ V/m)	Margin (dB)	Bandwidth (kHz)	Height (cm)	Pol	Azimuth (deg)	Corr. (dB/m)
37.921667	27.29	40.00	12.71	120.000	100.0	V	97.0	22
124.952222	32.96	43.52	10.56	120.000	100.0	V	6.0	22
265.763889	35.79	46.02	10.23	120.000	193.0	V	172.0	23
266.033333	36.19	46.02	9.83	120.000	189.0	V	173.0	23
271.907222	40.68	46.02	5.34	120.000	205.0	V	182.0	23
275.194444	36.68	46.02	9.34	120.000	190.0	V	287.0	23

Frequency (MHz)	MaxPeak (dB μ V/m)	Limit (dB μ V/m)	Margin (dB)	Bandwidth (kHz)	Height (cm)	Pol	Azimuth (deg)	Corr. (dB/m)
3216.000000	45.77	88.23	42.46	1000.000	116.0	H	110.0	7
4687.500000	47.19	73.98	26.79	1000.000	100.0	V	106.0	10
10599.500000	49.76	88.23	38.47	1000.000	100.0	V	247.0	18
14472.000000	53.47	73.98	20.51	1000.000	304.0	V	80.0	21
19222.000000	57.87	73.98	16.11	1000.000	394.0	H	318.0	18
22508.500000	57.70	73.98	16.28	1000.000	378.0	V	48.0	11
23917.500000	59.45	73.98	14.53	1000.000	372.0	V	285.0	11
31542.000000	61.73	73.98	12.25	1000.000	245.0	V	60.0	17
36427.500000	65.32	88.23	22.91	1000.000	100.0	H	240.0	19

Frequency (MHz)	Average (dB μ V/m)	Limit (dB μ V/m)	Margin (dB)	Bandwidth (kHz)	Height (cm)	Pol	Azimuth (deg)	Corr. (dB/m)
3216.000000	39.77	68.23	28.46	1000.000	116.0	H	110.0	7
4687.500000	38.23	53.98	15.75	1000.000	100.0	V	106.0	10
10599.500000	37.04	68.23	31.19	1000.000	100.0	V	247.0	18
14472.000000	40.79	53.98	13.19	1000.000	304.0	V	80.0	21
19222.000000	44.55	53.98	9.43	1000.000	394.0	H	318.0	18
22508.500000	44.24	53.98	9.74	1000.000	378.0	V	48.0	11
23917.500000	45.95	53.98	8.03	1000.000	372.0	V	285.0	11
31542.000000	48.55	53.98	5.43	1000.000	245.0	V	60.0	17
36427.500000	51.80	68.23	16.43	1000.000	100.0	H	240.0	19

Test Personnel: Michael Carlson
Supervising/Reviewing Engineer: NA
(Where Applicable) FCC Part 15E
Product Standard: RSS-247 Issue 2
Input Voltage: 120VAC / 60Hz
Pretest Verification w / Ambient Signals or BB Source: Yes

Test Date: 6/4/2021 – 6/24/2021
Limit Applied: 15.407b
Ambient Temperature: 21.5 °C
Relative Humidity: 40.2 %
Atmospheric Pressure: 988.8 mbar

Deviations, Additions, or Exclusions: None

**13.9 Worst Case Radiated Spurious Emissions Data (802.11n (80MHz), Channel 58)**

Frequency (MHz)	QuasiPeak (dB μ V/m)	Limit (dB μ V/m)	Margin (dB)	Bandwidth (kHz)	Height (cm)	Pol	Azimuth (deg)	Corr. (dB/m)
37.975556	27.37	40.00	12.63	120.000	100.0	V	115.0	22
113.905000	29.92	43.52	13.60	120.000	100.0	V	163.0	21
125.006111	36.03	43.52	7.50	120.000	100.0	V	0.0	22
269.697778	41.69	46.02	4.33	120.000	206.0	V	181.0	23
274.440000	37.81	46.02	8.21	120.000	190.0	V	277.0	23
275.302222	34.66	46.02	11.36	120.000	100.0	V	56.0	23

Frequency (MHz)	MaxPeak (dB μ V/m)	Limit (dB μ V/m)	Margin (dB)	Bandwidth (kHz)	Height (cm)	Pol	Azimuth (deg)	Corr. (dB/m)
3216.000000	46.86	88.23	41.37	1000.000	285.0	V	59.0	7
4687.500000	47.42	73.98	26.56	1000.000	100.0	V	104.0	10
5246.000000	64.50	88.23	23.73	1000.000	165.0	H	232.0	10
10519.500000	50.55	88.23	37.68	1000.000	100.0	V	244.0	18
14472.000000	55.04	73.98	18.94	1000.000	220.0	V	95.0	21
18810.500000	56.37	73.98	17.61	1000.000	388.0	H	139.0	19
21048.500000	56.24	73.98	17.74	1000.000	410.0	V	45.0	13
31254.000000	60.96	73.98	13.02	1000.000	100.0	V	280.0	17
31591.000000	62.83	73.98	11.15	1000.000	410.0	H	24.0	17
36453.000000	64.07	73.98	9.91	1000.000	393.0	H	261.0	19
36485.500000	64.46	73.98	9.52	1000.000	410.0	H	0.0	19

Frequency (MHz)	Average (dB μ V/m)	Limit (dB μ V/m)	Margin (dB)	Bandwidth (kHz)	Height (cm)	Pol	Azimuth (deg)	Corr. (dB/m)
3216.000000	41.69	68.23	26.54	1000.000	285.0	V	59.0	7
4687.500000	37.01	53.98	16.97	1000.000	100.0	V	104.0	10
5246.000000	52.77	68.23	15.46	1000.000	165.0	H	232.0	10
10519.500000	36.46	68.23	31.77	1000.000	100.0	V	244.0	18
14472.000000	45.62	53.98	8.36	1000.000	220.0	V	95.0	21
18810.500000	43.30	53.98	10.68	1000.000	388.0	H	139.0	19
21048.500000	42.74	53.98	11.24	1000.000	410.0	V	45.0	13
31254.000000	47.63	53.98	6.35	1000.000	100.0	V	280.0	17
31591.000000	48.99	53.98	4.99	1000.000	410.0	H	24.0	17
36453.000000	51.11	53.98	2.87	1000.000	393.0	H	261.0	19
36485.500000	50.93	53.98	3.05	1000.000	410.0	H	0.0	19

Test Personnel: Michael Carlson
Supervising/Reviewing Engineer: NA
(Where Applicable) FCC Part 15E
Product Standard: RSS-247 Issue 2
Input Voltage: 120VAC / 60Hz
Pretest Verification w / Ambient Signals or BB Source: Yes

Test Date: 6/4/2021 – 6/24/2021
Limit Applied: 15.407b
Ambient Temperature: 21.5 °C
Relative Humidity: 40.2 %
Atmospheric Pressure: 988.8 mbar

Deviations, Additions, or Exclusions: None



14 U-NII-2C Radiated Spurious Emissions

14.1 Worst Case Radiated Spurious Emissions Data (802.11a, Channel 100)

Frequency (MHz)	MaxPeak (dBµV/m)	Limit (dBµV/m)	Margin (dB)	Bandwidth (kHz)	Height (cm)	Pol	Azimuth (deg)	Corr. (dB/m)
2400.500000	42.63	88.23	45.60	1000.000	316.0	V	0.0	5
9648.000000	50.38	88.23	37.85	1000.000	320.0	V	296.0	17
11000.000000	55.98	73.98	18.00	1000.000	362.0	V	208.0	19
14472.000000	53.40	73.98	20.58	1000.000	126.0	V	239.0	21

Frequency (MHz)	Average (dBµV/m)	Limit (dBµV/m)	Margin (dB)	Bandwidth (kHz)	Height (cm)	Pol	Azimuth (deg)	Corr. (dB/m)
2400.500000	27.94	68.23	40.29	1000.000	316.0	V	0.0	5
9648.000000	38.82	68.23	29.41	1000.000	320.0	V	296.0	17
11000.000000	49.52	53.98	4.46	1000.000	362.0	V	208.0	19
14472.000000	40.42	53.98	13.56	1000.000	126.0	V	239.0	21

Test Personnel:	Michael Carlson	Test Date:	6/4/2021 – 6/24/2021
Supervising/Reviewing Engineer:		Limit Applied:	15.407b
(Where Applicable)	NA	Ambient Temperature:	21.5 °C
	FCC Part 15E	Relative Humidity:	40.2 %
Product Standard:	RSS-247 Issue 2	Atmospheric Pressure:	988.8 mbar
Input Voltage:	120VAC / 60Hz		
Pretest Verification w / Ambient			
Signals or BB Source:	Yes		

Deviations, Additions, or Exclusions: None

**14.2 Worst Case Radiated Spurious Emissions Data (802.11a, Channel 116)**

Frequency (MHz)	QuasiPeak (dB μ V/m)	Limit (dB μ V/m)	Margin (dB)	Bandwidth (kHz)	Height (cm)	Pol	Azimuth (deg)	Corr. (dB/m)
38.245000	28.46	40.00	11.54	120.000	101.0	V	48.0	22
124.952222	29.78	43.52	13.74	120.000	100.0	V	0.0	22
156.854444	32.07	43.52	11.45	120.000	100.0	V	47.0	22
163.536667	31.02	43.52	12.50	120.000	100.0	V	38.0	22
169.841667	28.45	43.52	15.07	120.000	99.0	V	214.0	21
258.866111	36.01	46.02	10.01	120.000	100.0	V	48.0	22
269.967222	43.13	46.02	2.89	120.000	215.0	V	174.0	23

Frequency (MHz)	MaxPeak (dB μ V/m)	Limit (dB μ V/m)	Margin (dB)	Bandwidth (kHz)	Height (cm)	Pol	Azimuth (deg)	Corr. (dB/m)
2401.000000	42.42	88.23	45.81	1000.000	157.0	V	186.0	5
9648.000000	52.39	88.23	35.84	1000.000	326.0	V	302.0	17
14472.000000	54.35	73.98	19.63	1000.000	125.0	V	244.0	21
22339.000000	57.42	73.98	16.56	1000.000	386.0	H	0.0	11
23721.500000	57.68	73.98	16.30	1000.000	384.0	H	0.0	11
31616.500000	62.56	73.98	11.42	1000.000	100.0	H	131.0	17
36437.500000	64.01	73.98	9.97	1000.000	410.0	H	0.0	19
36439.500000	64.92	73.98	9.06	1000.000	410.0	H	295.0	19
36459.500000	64.89	73.98	9.09	1000.000	100.0	H	233.0	19

Frequency (MHz)	Average (dB μ V/m)	Limit (dB μ V/m)	Margin (dB)	Bandwidth (kHz)	Height (cm)	Pol	Azimuth (deg)	Corr. (dB/m)
2401.000000	28.69	68.23	39.54	1000.000	157.0	V	186.0	5
9648.000000	42.84	68.23	25.39	1000.000	326.0	V	302.0	17
14472.000000	43.17	53.98	10.81	1000.000	125.0	V	244.0	21
22339.000000	43.43	53.98	10.55	1000.000	386.0	H	0.0	11
23721.500000	44.58	53.98	9.40	1000.000	384.0	H	0.0	11
31616.500000	48.90	53.98	5.08	1000.000	100.0	H	131.0	17
36437.500000	51.17	53.98	2.81	1000.000	410.0	H	0.0	19
36439.500000	51.46	53.98	2.52	1000.000	410.0	H	295.0	19
36459.500000	51.28	53.98	2.70	1000.000	100.0	H	233.0	19

Test Personnel: Michael Carlson
Supervising/Reviewing Engineer: NA
(Where Applicable) FCC Part 15E
Product Standard: RSS-247 Issue 2
Input Voltage: 120VAC / 60Hz
Pretest Verification w / Ambient Signals or BB Source: Yes

Test Date: 6/4/2021 – 6/24/2021
Limit Applied: 15.407b
Ambient Temperature: 21.5 °C
Relative Humidity: 40.2 %
Atmospheric Pressure: 988.8 mbar

Deviations, Additions, or Exclusions: None



14.3 Worst Case Radiated Spurious Emissions Data (802.11a, Channel 140)

Frequency (MHz)	MaxPeak (dBµV/m)	Limit (dBµV/m)	Margin (dB)	Bandwidth (kHz)	Height (cm)	Pol	Azimuth (deg)	Corr. (dB/m)
2401.000000	41.66	88.23	46.57	1000.000	324.0	V	174.0	5
9648.000000	50.56	88.23	37.67	1000.000	376.0	V	302.0	17
11400.000000	57.89	73.98	16.09	1000.000	410.0	V	105.0	19
14472.000000	54.71	73.98	19.27	1000.000	125.0	V	247.0	21

Frequency (MHz)	Average (dBµV/m)	Limit (dBµV/m)	Margin (dB)	Bandwidth (kHz)	Height (cm)	Pol	Azimuth (deg)	Corr. (dB/m)
2401.000000	27.69	68.23	40.54	1000.000	324.0	V	174.0	5
9648.000000	39.89	68.23	28.34	1000.000	376.0	V	302.0	17
11400.000000	53.32	53.98	0.66	1000.000	410.0	V	105.0	19
14472.000000	44.88	53.98	9.10	1000.000	125.0	V	247.0	21

Test Personnel: Michael Carlson
Supervising/Reviewing Engineer: _____
(Where Applicable) NA
FCC Part 15E
Product Standard: RSS-247 Issue 2
Input Voltage: 120VAC / 60Hz
Pretest Verification w / Ambient
Signals or BB Source: Yes

Test Date: 6/4/2021 – 6/24/2021
Limit Applied: 15.407b
Ambient Temperature: 21.5 °C
Relative Humidity: 40.2 %
Atmospheric Pressure: 988.8 mbar

Deviations, Additions, or Exclusions: None



14.4 Worst Case Radiated Spurious Emissions Data (802.11n, Channel 100)

Frequency (MHz)	MaxPeak (dBµV/m)	Limit (dBµV/m)	Margin (dB)	Bandwidth (kHz)	Height (cm)	Pol	Azimuth (deg)	Corr. (dB/m)
2402.500000	40.40	88.23	47.83	1000.000	109.0	V	308.0	5
9648.000000	50.89	88.23	37.34	1000.000	346.0	V	296.0	17
11000.000000	56.84	73.98	17.14	1000.000	303.0	V	67.0	19
14472.000000	54.19	73.98	19.79	1000.000	309.0	V	249.0	21

Frequency (MHz)	Average (dBµV/m)	Limit (dBµV/m)	Margin (dB)	Bandwidth (kHz)	Height (cm)	Pol	Azimuth (deg)	Corr. (dB/m)
2402.500000	26.33	68.23	41.90	1000.000	109.0	V	308.0	5
9648.000000	39.74	68.23	28.49	1000.000	346.0	V	296.0	17
11000.000000	51.36	53.98	2.62	1000.000	303.0	V	67.0	19
14472.000000	42.45	53.98	11.53	1000.000	309.0	V	249.0	21

Test Personnel:	<u>Michael Carlson</u>	Test Date:	<u>6/4/2021 – 6/24/2021</u>
Supervising/Reviewing Engineer:	<u>NA</u>	Limit Applied:	<u>15.407b</u>
(Where Applicable)	<u>FCC Part 15E</u>	Ambient Temperature:	<u>21.5 °C</u>
Product Standard:	<u>RSS-247 Issue 2</u>	Relative Humidity:	<u>40.2 %</u>
Input Voltage:	<u>120VAC / 60Hz</u>	Atmospheric Pressure:	<u>988.8 mbar</u>
Pretest Verification w / Ambient Signals or BB Source:	<u>Yes</u>		

Deviations, Additions, or Exclusions: None

**14.5 Worst Case Radiated Spurious Emissions Data (802.11n, Channel 116)**

Frequency (MHz)	QuasiPeak (dB μ V/m)	Limit (dB μ V/m)	Margin (dB)	Bandwidth (kHz)	Height (cm)	Pol	Azimuth (deg)	Corr. (dB/m)
37.921667	27.21	40.00	12.79	120.000	100.0	V	119.0	22
113.689444	29.71	43.52	13.81	120.000	100.0	V	164.0	21
124.952222	33.78	43.52	9.74	120.000	100.0	V	0.0	22
256.333333	35.66	46.02	10.36	120.000	100.0	V	50.0	22
267.218889	39.86	46.02	6.16	120.000	187.0	V	175.0	23
270.075000	34.92	46.02	11.11	120.000	207.0	V	184.0	23
270.775556	38.84	46.02	7.18	120.000	200.0	V	-3.0	23
400.593889	33.09	46.02	12.93	120.000	116.0	V	16.0	26

Frequency (MHz)	MaxPeak (dB μ V/m)	Limit (dB μ V/m)	Margin (dB)	Bandwidth (kHz)	Height (cm)	Pol	Azimuth (deg)	Corr. (dB/m)
2402.500000	43.30	88.23	44.93	1000.000	100.0	V	186.0	5
9648.000000	51.92	88.23	36.31	1000.000	298.0	V	304.0	17
14472.000000	54.05	73.98	19.93	1000.000	125.0	V	244.0	21
19380.000000	58.08	73.98	15.90	1000.000	297.0	H	165.0	17
22323.000000	56.90	73.98	17.08	1000.000	285.0	V	340.0	11
23874.000000	59.22	73.98	14.76	1000.000	312.0	H	43.0	11
31309.000000	62.21	73.98	11.77	1000.000	135.0	H	12.0	17
36466.000000	65.41	73.98	8.57	1000.000	100.0	H	-2.0	19

Frequency (MHz)	Average (dB μ V/m)	Limit (dB μ V/m)	Margin (dB)	Bandwidth (kHz)	Height (cm)	Pol	Azimuth (deg)	Corr. (dB/m)
2402.500000	28.62	68.23	39.61	1000.000	100.0	V	186.0	5
9648.000000	42.33	68.23	25.90	1000.000	298.0	V	304.0	17
14472.000000	43.43	53.98	10.55	1000.000	125.0	V	244.0	21
19380.000000	43.98	53.98	10.00	1000.000	297.0	H	165.0	17
22323.000000	43.17	53.98	10.81	1000.000	285.0	V	340.0	11
23874.000000	45.80	53.98	8.18	1000.000	312.0	H	43.0	11
31309.000000	48.65	53.98	5.33	1000.000	135.0	H	12.0	17
36466.000000	51.95	53.98	2.03	1000.000	100.0	H	-2.0	19

Test Personnel: Michael Carlson
Supervising/Reviewing Engineer: NA
(Where Applicable) FCC Part 15E
Product Standard: RSS-247 Issue 2
Input Voltage: 120VAC / 60Hz
Pretest Verification w / Ambient Signals or BB Source: Yes

Test Date: 6/4/2021 – 6/24/2021
Limit Applied: 15.407b
Ambient Temperature: 21.5 °C
Relative Humidity: 40.2 %
Atmospheric Pressure: 988.8 mbar

Deviations, Additions, or Exclusions: None



14.6 Worst Case Radiated Spurious Emissions Data (802.11n, Channel 140)

Frequency (MHz)	MaxPeak (dBµV/m)	Limit (dBµV/m)	Margin (dB)	Bandwidth (kHz)	Height (cm)	Pol	Azimuth (deg)	Corr. (dB/m)
2400.500000	40.81	88.23	47.42	1000.000	157.0	V	60.0	5
9648.000000	50.32	88.23	37.91	1000.000	308.0	V	277.0	17
14472.000000	55.19	73.98	18.79	1000.000	144.0	V	244.0	21

Frequency (MHz)	Average (dBµV/m)	Limit (dBµV/m)	Margin (dB)	Bandwidth (kHz)	Height (cm)	Pol	Azimuth (deg)	Corr. (dB/m)
2400.500000	26.83	68.23	41.40	1000.000	157.0	V	60.0	5
9648.000000	39.43	68.23	28.80	1000.000	308.0	V	277.0	17
14472.000000	43.14	53.98	10.84	1000.000	144.0	V	244.0	21

Test Personnel:	<u>Michael Carlson</u>	Test Date:	<u>6/4/2021 – 6/24/2021</u>
Supervising/Reviewing Engineer:	<u>NA</u>	Limit Applied:	<u>15.407b</u>
(Where Applicable)	<u>FCC Part 15E</u>	Ambient Temperature:	<u>21.5 °C</u>
Product Standard:	<u>RSS-247 Issue 2</u>	Relative Humidity:	<u>40.2 %</u>
Input Voltage:	<u>120VAC / 60Hz</u>	Atmospheric Pressure:	<u>988.8 mbar</u>
Pretest Verification w / Ambient Signals or BB Source:	<u>Yes</u>		

Deviations, Additions, or Exclusions: None

**14.7 Worst Case Radiated Spurious Emissions Data (802.11n (40MHz), Channel 102)**

Frequency (MHz)	MaxPeak (dBμV/m)	Limit (dBμV/m)	Margin (dB)	Bandwidth (kHz)	Height (cm)	Pol	Azimuth (deg)	Corr. (dB/m)
3216.000000	45.52	88.23	42.71	1000.000	116.0	H	110.0	7
4687.500000	46.70	73.98	27.28	1000.000	100.0	V	103.0	10
9648.000000	49.53	88.23	38.70	1000.000	185.0	V	92.0	17
10999.500000	53.47	73.98	20.51	1000.000	188.0	V	241.0	19
14472.000000	55.68	73.98	18.30	1000.000	302.0	V	88.0	21

Frequency (MHz)	Average (dBμV/m)	Limit (dBμV/m)	Margin (dB)	Bandwidth (kHz)	Height (cm)	Pol	Azimuth (deg)	Corr. (dB/m)
3216.000000	39.06	68.23	29.17	1000.000	116.0	H	110.0	7
4687.500000	36.71	53.98	17.27	1000.000	100.0	V	103.0	10
9648.000000	37.24	68.23	30.99	1000.000	185.0	V	92.0	17
10999.500000	44.73	53.98	9.25	1000.000	188.0	V	241.0	19
14472.000000	44.64	53.98	9.34	1000.000	302.0	V	88.0	21

Test Personnel: Michael Carlson
Supervising/Reviewing Engineer: _____
(Where Applicable) NA
FCC Part 15E
Product Standard: RSS-247 Issue 2
Input Voltage: 120VAC / 60Hz
Pretest Verification w / Ambient
Signals or BB Source: Yes

Test Date: 6/4/2021 – 6/24/2021
Limit Applied: 15.407b
Ambient Temperature: 21.5 °C
Relative Humidity: 40.2 %
Atmospheric Pressure: 988.8 mbar

Deviations, Additions, or Exclusions: None

**14.8 Worst Case Radiated Spurious Emissions Data (802.11n (40MHz), Channel 110)**

Frequency (MHz)	QuasiPeak (dBµV/m)	Limit (dBµV/m)	Margin (dB)	Bandwidth (kHz)	Height (cm)	Pol	Azimuth (deg)	Corr. (dB/m)
37.760000	26.96	40.00	13.04	120.000	100.0	V	90.0	22
114.066667	29.43	43.52	14.09	120.000	99.0	V	177.0	21
125.006111	36.81	43.52	6.71	120.000	100.0	V	-1.0	22
164.452778	28.89	43.52	14.63	120.000	100.0	V	0.0	22
258.920000	35.55	46.02	10.47	120.000	100.0	V	47.0	22
271.583889	41.49	46.02	4.53	120.000	204.0	V	183.0	23
611.245556	31.64	46.02	14.38	120.000	100.0	H	230.0	32
977.851667	38.49	53.98	15.49	120.000	117.0	H	288.0	38

Frequency (MHz)	MaxPeak (dBµV/m)	Limit (dBµV/m)	Margin (dB)	Bandwidth (kHz)	Height (cm)	Pol	Azimuth (deg)	Corr. (dB/m)
3216.000000	45.84	88.23	42.39	1000.000	109.0	H	106.0	7
4687.500000	46.79	73.98	27.19	1000.000	100.0	V	103.0	10
9648.000000	50.20	88.23	38.03	1000.000	189.0	V	94.0	17
11079.500000	55.33	73.98	18.65	1000.000	169.0	V	246.0	18
14472.000000	54.84	73.98	19.14	1000.000	280.0	V	92.0	21
19387.000000	57.42	73.98	16.56	1000.000	410.0	H	0.0	17
22174.000000	57.36	73.98	16.62	1000.000	308.0	V	336.0	11
23841.000000	58.48	73.98	15.50	1000.000	381.0	V	0.0	11
31489.500000	61.69	73.98	12.29	1000.000	109.0	H	348.0	17
36446.500000	64.90	73.98	9.08	1000.000	109.0	H	48.0	19

Frequency (MHz)	Average (dBµV/m)	Limit (dBµV/m)	Margin (dB)	Bandwidth (kHz)	Height (cm)	Pol	Azimuth (deg)	Corr. (dB/m)
3216.000000	38.63	68.23	29.60	1000.000	109.0	H	106.0	7
4687.500000	36.52	53.98	17.46	1000.000	100.0	V	103.0	10
9648.000000	38.56	68.23	29.67	1000.000	189.0	V	94.0	17
11079.500000	49.47	53.98	4.51	1000.000	169.0	V	246.0	18
14472.000000	45.49	53.98	8.49	1000.000	280.0	V	92.0	21
19387.000000	44.22	53.98	9.76	1000.000	410.0	H	0.0	17
22174.000000	43.76	53.98	10.22	1000.000	308.0	V	336.0	11
23841.000000	45.00	53.98	8.98	1000.000	381.0	V	0.0	11
31489.500000	48.55	53.98	5.43	1000.000	109.0	H	348.0	17
36446.500000	51.86	53.98	2.12	1000.000	109.0	H	48.0	19

Test Personnel: Michael Carlson
Supervising/Reviewing Engineer: NA
(Where Applicable) FCC Part 15E
Product Standard: RSS-247 Issue 2
Input Voltage: 120VAC / 60Hz
Pretest Verification w / Ambient Signals or BB Source: Yes

Test Date: 6/4/2021 – 6/24/2021
Limit Applied: 15.407b
Ambient Temperature: 21.5 °C
Relative Humidity: 40.2 %
Atmospheric Pressure: 988.8 mbar

Deviations, Additions, or Exclusions: None



14.9 Worst Case Radiated Spurious Emissions Data (802.11n (40MHz), Channel 134)

Frequency (MHz)	MaxPeak (dBµV/m)	Limit (dBµV/m)	Margin (dB)	Bandwidth (kHz)	Height (cm)	Pol	Azimuth (deg)	Corr. (dB/m)
3216.000000	45.20	88.23	43.03	1000.000	117.0	H	109.0	7
4687.500000	46.54	73.98	27.44	1000.000	100.0	V	143.0	10
11079.500000	55.63	73.98	18.35	1000.000	183.0	V	248.0	18
14472.000000	53.55	73.98	20.43	1000.000	291.0	V	82.0	21

Frequency (MHz)	Average (dBµV/m)	Limit (dBµV/m)	Margin (dB)	Bandwidth (kHz)	Height (cm)	Pol	Azimuth (deg)	Corr. (dB/m)
3216.000000	38.73	68.23	29.50	1000.000	117.0	H	109.0	7
4687.500000	36.74	53.98	17.24	1000.000	100.0	V	143.0	10
11079.500000	50.08	53.98	3.90	1000.000	183.0	V	248.0	18
14472.000000	41.10	53.98	12.88	1000.000	291.0	V	82.0	21

Test Personnel:	<u>Michael Carlson</u>	Test Date:	<u>6/4/2021 – 6/24/2021</u>
Supervising/Reviewing Engineer:	<u>NA</u>	Limit Applied:	<u>15.407b</u>
(Where Applicable)	<u>FCC Part 15E</u>	Ambient Temperature:	<u>21.5 °C</u>
Product Standard:	<u>RSS-247 Issue 2</u>	Relative Humidity:	<u>40.2 %</u>
Input Voltage:	<u>120VAC / 60Hz</u>	Atmospheric Pressure:	<u>988.8 mbar</u>
Pretest Verification w / Ambient Signals or BB Source:	<u>Yes</u>		

Deviations, Additions, or Exclusions: None



14.10 Worst Case Radiated Spurious Emissions Data (802.11n (80MHz), Channel 106)

Frequency (MHz)	MaxPeak (dBµV/m)	Limit (dBµV/m)	Margin (dB)	Bandwidth (kHz)	Height (cm)	Pol	Azimuth (deg)	Corr. (dB/m)
3216.000000	45.24	88.23	42.99	1000.000	100.0	V	218.0	7
4687.500000	46.30	73.98	27.68	1000.000	100.0	V	103.0	10
5470.000000	57.49	88.23	30.74	1000.000	324.0	H	227.0	10
10999.500000	55.20	73.98	18.78	1000.000	393.0	V	218.0	19
14472.000000	54.33	73.98	19.65	1000.000	410.0	V	88.0	21

Frequency (MHz)	Average (dBµV/m)	Limit (dBµV/m)	Margin (dB)	Bandwidth (kHz)	Height (cm)	Pol	Azimuth (deg)	Corr. (dB/m)
3216.000000	38.54	68.23	29.69	1000.000	100.0	V	218.0	7
4687.500000	36.37	53.98	17.61	1000.000	100.0	V	103.0	10
5470.000000	46.07	68.23	22.16	1000.000	324.0	H	227.0	10
10999.500000	47.55	53.98	6.43	1000.000	393.0	V	218.0	19
14472.000000	43.22	53.98	10.76	1000.000	410.0	V	88.0	21

Test Personnel: Michael Carlson
Supervising/Reviewing Engineer: _____
(Where Applicable) NA
FCC Part 15E
Product Standard: RSS-247 Issue 2
Input Voltage: 120VAC / 60Hz
Pretest Verification w / Ambient
Signals or BB Source: Yes

Test Date: 6/4/2021 – 6/24/2021
Limit Applied: 15.407b
Ambient Temperature: 21.5 °C
Relative Humidity: 40.2 %
Atmospheric Pressure: 988.8 mbar

Deviations, Additions, or Exclusions: None

**14.11 Worst Case Radiated Spurious Emissions Data (802.11n (80MHz), Channel 138)**

Frequency (MHz)	QuasiPeak (dB μ V/m)	Limit (dB μ V/m)	Margin (dB)	Bandwidth (kHz)	Height (cm)	Pol	Azimuth (deg)	Corr. (dB/m)
114.228333	29.27	43.52	14.25	120.000	100.0	V	126.0	21
124.952222	32.44	43.52	11.08	120.000	100.0	V	345.0	22
259.620556	36.05	46.02	9.97	120.000	100.0	V	46.0	22
269.697778	41.07	46.02	4.95	120.000	205.0	V	171.0	23
276.164444	34.36	46.02	11.66	120.000	175.0	V	284.0	23

Frequency (MHz)	MaxPeak (dB μ V/m)	Limit (dB μ V/m)	Margin (dB)	Bandwidth (kHz)	Height (cm)	Pol	Azimuth (deg)	Corr. (dB/m)
3216.000000	45.00	88.23	43.23	1000.000	109.0	H	108.0	7
4687.500000	46.85	73.98	27.13	1000.000	100.0	V	102.0	10
9648.000000	48.77	88.23	39.46	1000.000	143.0	V	93.0	17
11380.000000	52.72	73.98	21.26	1000.000	222.0	H	201.0	19
14472.000000	55.69	73.98	18.29	1000.000	240.0	V	93.0	21
20090.000000	55.67	73.98	18.31	1000.000	100.0	H	12.0	15
22851.500000	57.13	73.98	16.85	1000.000	384.0	V	33.0	10
23861.000000	57.80	73.98	16.18	1000.000	381.0	H	238.0	11
31489.000000	62.53	73.98	11.45	1000.000	126.0	H	298.0	17
36473.000000	64.49	73.98	9.49	1000.000	410.0	H	0.0	19

Frequency (MHz)	Average (dB μ V/m)	Limit (dB μ V/m)	Margin (dB)	Bandwidth (kHz)	Height (cm)	Pol	Azimuth (deg)	Corr. (dB/m)
3216.000000	38.13	68.23	30.10	1000.000	109.0	H	108.0	7
4687.500000	36.03	53.98	17.95	1000.000	100.0	V	102.0	10
9648.000000	35.39	68.23	32.84	1000.000	143.0	V	93.0	17
11380.000000	44.00	53.98	9.98	1000.000	222.0	H	201.0	19
14472.000000	45.50	53.98	8.48	1000.000	240.0	V	93.0	21
20090.000000	42.71	53.98	11.27	1000.000	100.0	H	12.0	15
22851.500000	43.55	53.98	10.43	1000.000	384.0	V	33.0	10
23861.000000	44.51	53.98	9.47	1000.000	381.0	H	238.0	11
31489.000000	49.12	53.98	4.86	1000.000	126.0	H	298.0	17
36473.000000	50.97	53.98	3.01	1000.000	410.0	H	0.0	19

Test Personnel: Michael Carlson
Supervising/Reviewing Engineer: NA
(Where Applicable) FCC Part 15E
Product Standard: RSS-247 Issue 2
Input Voltage: 120VAC / 60Hz
Pretest Verification w / Ambient Signals or BB Source: Yes

Test Date: 6/4/2021 – 6/24/2021
Limit Applied: 15.407b
Ambient Temperature: 21.5 °C
Relative Humidity: 40.2 %
Atmospheric Pressure: 988.8 mbar

Deviations, Additions, or Exclusions: None

**15 U-NII-3 Radiated Spurious Emissions****15.1 Worst Case Radiated Spurious Emissions Data (802.11a, Channel 149)**

Frequency (MHz)	MaxPeak (dB μ V/m)	Limit (dB μ V/m)	Margin (dB)	Bandwidth (kHz)	Height (cm)	Pol	Azimuth (deg)	Corr. (dB/m)
9648.000000	50.80	88.23	37.43	1000.000	300.0	V	298.0	17
11490.000000	57.63	73.98	16.35	1000.000	410.0	V	287.0	19
14472.000000	54.01	73.98	19.97	1000.000	109.0	V	244.0	21

Frequency (MHz)	Average (dB μ V/m)	Limit (dB μ V/m)	Margin (dB)	Bandwidth (kHz)	Height (cm)	Pol	Azimuth (deg)	Corr. (dB/m)
9648.000000	39.91	68.23	28.32	1000.000	300.0	V	298.0	17
11490.000000	53.43	53.98	0.55	1000.000	410.0	V	287.0	19
14472.000000	43.07	53.98	10.91	1000.000	109.0	V	244.0	21

Test Personnel: Michael Carlson
Supervising/Reviewing Engineer: NA
(Where Applicable) FCC Part 15E
Product Standard: RSS-247 Issue 2
Input Voltage: 120VAC / 60Hz
Pretest Verification w / Ambient Signals or BB Source: Yes

Test Date: 6/4/2021 – 6/24/2021
Limit Applied: 15.407b
Ambient Temperature: 21.5 °C
Relative Humidity: 40.2 %
Atmospheric Pressure: 988.8 mbar

Deviations, Additions, or Exclusions: None

**15.2 Worst Case Radiated Spurious Emissions Data (802.11a, Channel 157)**

Frequency (MHz)	QuasiPeak (dB μ V/m)	Limit (dB μ V/m)	Margin (dB)	Bandwidth (kHz)	Height (cm)	Pol	Azimuth (deg)	Corr. (dB/m)
124.952222	31.20	43.52	12.33	120.000	100.0	V	-1.0	22
267.380556	40.80	46.02	5.22	120.000	207.0	V	173.0	23
270.290556	42.46	46.02	3.56	120.000	206.0	V	274.0	23
270.667778	42.44	46.02	3.58	120.000	209.0	V	281.0	23
271.368333	41.71	46.02	4.31	120.000	210.0	V	278.0	23

Frequency (MHz)	MaxPeak (dB μ V/m)	Limit (dB μ V/m)	Margin (dB)	Bandwidth (kHz)	Height (cm)	Pol	Azimuth (deg)	Corr. (dB/m)
3216.000000	45.78	88.23	42.45	1000.000	321.0	V	140.0	7
4687.500000	47.03	73.98	26.95	1000.000	100.0	V	175.0	10
4824.000000	50.42	73.98	23.56	1000.000	331.0	H	302.0	10
4829.500000	48.84	73.98	25.14	1000.000	297.0	H	23.0	10
11570.000000	54.86	73.98	19.12	1000.000	211.0	V	327.0	19
14472.000000	53.28	73.98	20.70	1000.000	308.0	V	160.0	21
20930.500000	54.65	73.98	19.33	1000.000	390.0	V	291.0	13
23727.500000	57.96	73.98	16.02	1000.000	387.0	V	0.0	11
31395.000000	61.84	73.98	12.14	1000.000	100.0	H	0.0	17
36441.000000	64.23	73.98	9.75	1000.000	100.0	H	0.0	19
36457.500000	64.81	73.98	9.17	1000.000	100.0	H	177.0	19
36476.500000	64.16	73.98	9.82	1000.000	410.0	H	334.0	19

Frequency (MHz)	Average (dB μ V/m)	Limit (dB μ V/m)	Margin (dB)	Bandwidth (kHz)	Height (cm)	Pol	Azimuth (deg)	Corr. (dB/m)
3216.000000	40.30	68.23	27.93	1000.000	321.0	V	140.0	7
4687.500000	37.51	53.98	16.47	1000.000	100.0	V	175.0	10
4824.000000	38.00	53.98	15.98	1000.000	331.0	H	302.0	10
4829.500000	31.39	53.98	22.59	1000.000	297.0	H	23.0	10
11570.000000	47.19	53.98	6.79	1000.000	211.0	V	327.0	19
14472.000000	40.50	53.98	13.48	1000.000	308.0	V	160.0	21
20930.500000	41.89	53.98	12.09	1000.000	390.0	V	291.0	13
23727.500000	44.53	53.98	9.45	1000.000	387.0	V	0.0	11
31395.000000	48.61	53.98	5.37	1000.000	100.0	H	0.0	17
36441.000000	51.06	53.98	2.92	1000.000	100.0	H	0.0	19
36457.500000	51.14	53.98	2.84	1000.000	100.0	H	177.0	19
36476.500000	51.02	53.98	2.96	1000.000	410.0	H	334.0	19

Test Personnel: Michael Carlson
Supervising/Reviewing Engineer: NA
(Where Applicable) FCC Part 15E
Product Standard: RSS-247 Issue 2
Input Voltage: 120VAC / 60Hz
Pretest Verification w / Ambient Signals or BB Source: Yes

Test Date: 6/4/2021 – 6/24/2021
Limit Applied: 15.407b
Ambient Temperature: 21.5 °C
Relative Humidity: 40.2 %
Atmospheric Pressure: 988.8 mbar

Deviations, Additions, or Exclusions: None

**15.3 Worst Case Radiated Spurious Emissions Data (802.11a, Channel 165)**

Frequency (MHz)	MaxPeak (dB μ V/m)	Limit (dB μ V/m)	Margin (dB)	Bandwidth (kHz)	Height (cm)	Pol	Azimuth (deg)	Corr. (dB/m)
3216.000000	45.78	88.23	42.45	1000.000	274.0	V	138.0	7
4531.500000	44.93	73.98	29.05	1000.000	100.0	V	164.0	9
4687.500000	47.59	73.98	26.39	1000.000	100.0	V	184.0	10
4824.000000	44.83	73.98	29.15	1000.000	331.0	H	297.0	10
9648.000000	49.93	88.23	38.30	1000.000	197.0	V	173.0	17
11650.000000	55.16	73.98	18.82	1000.000	189.0	H	293.0	19
14472.000000	55.47	73.98	18.51	1000.000	237.0	V	172.0	21

Frequency (MHz)	Average (dB μ V/m)	Limit (dB μ V/m)	Margin (dB)	Bandwidth (kHz)	Height (cm)	Pol	Azimuth (deg)	Corr. (dB/m)
3216.000000	40.27	68.23	27.96	1000.000	274.0	V	138.0	7
4531.500000	34.02	53.98	19.96	1000.000	100.0	V	164.0	9
4687.500000	37.87	53.98	16.11	1000.000	100.0	V	184.0	10
4824.000000	31.68	53.98	22.30	1000.000	331.0	H	297.0	10
9648.000000	37.68	68.23	30.55	1000.000	197.0	V	173.0	17
11650.000000	47.94	53.98	6.04	1000.000	189.0	H	293.0	19
14472.000000	46.15	53.98	7.83	1000.000	237.0	V	172.0	21

Test Personnel: Michael Carlson
Supervising/Reviewing Engineer: _____
(Where Applicable) NA
FCC Part 15E
Product Standard: RSS-247 Issue 2
Input Voltage: 120VAC / 60Hz
Pretest Verification w / Ambient
Signals or BB Source: Yes

Test Date: 6/4/2021 – 6/24/2021
Limit Applied: 15.407b
Ambient Temperature: 21.5 °C
Relative Humidity: 40.2 %
Atmospheric Pressure: 988.8 mbar

Deviations, Additions, or Exclusions: None



15.4 Worst Case Radiated Spurious Emissions Data (802.11n, Channel 149)

Frequency (MHz)	MaxPeak (dBµV/m)	Limit (dBµV/m)	Margin (dB)	Bandwidth (kHz)	Height (cm)	Pol	Azimuth (deg)	Corr. (dB/m)
3216.000000	45.00	88.23	43.23	1000.000	318.0	H	262.0	7
4531.500000	45.36	73.98	28.62	1000.000	275.0	V	103.0	9
4687.500000	47.46	73.98	26.52	1000.000	264.0	V	103.0	10
9648.000000	49.02	88.23	39.21	1000.000	410.0	V	241.0	17
11489.500000	52.88	73.98	21.10	1000.000	247.0	V	262.0	19
14472.000000	55.47	73.98	18.51	1000.000	246.0	V	91.0	21

Frequency (MHz)	Average (dBµV/m)	Limit (dBµV/m)	Margin (dB)	Bandwidth (kHz)	Height (cm)	Pol	Azimuth (deg)	Corr. (dB/m)
3216.000000	38.52	68.23	29.71	1000.000	318.0	H	262.0	7
4531.500000	33.86	53.98	20.12	1000.000	275.0	V	103.0	9
4687.500000	37.87	53.98	16.11	1000.000	264.0	V	103.0	10
9648.000000	35.43	68.23	32.80	1000.000	410.0	V	241.0	17
11489.500000	43.04	53.98	10.94	1000.000	247.0	V	262.0	19
14472.000000	45.63	53.98	8.35	1000.000	246.0	V	91.0	21

Test Personnel: Michael Carlson
Supervising/Reviewing Engineer: NA
(Where Applicable) FCC Part 15E
Product Standard: RSS-247 Issue 2
Input Voltage: 120VAC / 60Hz
Pretest Verification w / Ambient Signals or BB Source: Yes

Test Date: 6/4/2021 – 6/24/2021
Limit Applied: 15.407b
Ambient Temperature: 21.5 °C
Relative Humidity: 40.2 %
Atmospheric Pressure: 988.8 mbar

Deviations, Additions, or Exclusions: None

**15.5 Worst Case Radiated Spurious Emissions Data (802.11n, Channel 157)**

Frequency (MHz)	QuasiPeak (dB μ V/m)	Limit (dB μ V/m)	Margin (dB)	Bandwidth (kHz)	Height (cm)	Pol	Azimuth (deg)	Corr. (dB/m)
38.137222	28.65	40.00	11.35	120.000	102.0	V	48.0	22
125.006111	38.98	43.52	4.55	120.000	101.0	V	0.0	22
256.333333	35.89	46.02	10.14	120.000	101.0	H	164.0	22
275.302222	33.17	46.02	12.85	120.000	99.0	H	296.0	23
406.360000	34.38	46.02	11.64	120.000	101.0	V	277.0	26

Frequency (MHz)	MaxPeak (dB μ V/m)	Limit (dB μ V/m)	Margin (dB)	Bandwidth (kHz)	Height (cm)	Pol	Azimuth (deg)	Corr. (dB/m)
3216.000000	44.67	88.23	43.56	1000.000	321.0	V	132.0	7
4687.500000	47.33	73.98	26.65	1000.000	100.0	V	185.0	10
4824.000000	54.36	73.98	19.62	1000.000	351.0	H	306.0	10
11570.000000	56.69	73.98	17.29	1000.000	224.0	V	326.0	19
14472.000000	52.38	73.98	21.60	1000.000	227.0	V	161.0	21
19389.000000	57.01	73.98	16.97	1000.000	355.0	V	36.0	17
22849.000000	58.39	73.98	15.59	1000.000	410.0	H	0.0	10
23767.000000	59.28	73.98	14.70	1000.000	410.0	V	0.0	11
31533.500000	61.86	73.98	12.12	1000.000	410.0	H	188.0	17
36450.000000	65.01	73.98	8.97	1000.000	410.0	V	212.0	19

Frequency (MHz)	Average (dB μ V/m)	Limit (dB μ V/m)	Margin (dB)	Bandwidth (kHz)	Height (cm)	Pol	Azimuth (deg)	Corr. (dB/m)
3216.000000	37.60	68.23	30.63	1000.000	321.0	V	132.0	7
4687.500000	37.78	53.98	16.20	1000.000	100.0	V	185.0	10
4824.000000	42.21	53.98	11.77	1000.000	351.0	H	306.0	10
11570.000000	50.49	53.98	3.49	1000.000	224.0	V	326.0	19
14472.000000	39.28	53.98	14.70	1000.000	227.0	V	161.0	21
19389.000000	43.75	53.98	10.23	1000.000	355.0	V	36.0	17
22849.000000	45.02	53.98	8.96	1000.000	410.0	H	0.0	10
23767.000000	46.19	53.98	7.79	1000.000	410.0	V	0.0	11
31533.500000	48.51	53.98	5.47	1000.000	410.0	H	188.0	17
36450.000000	51.71	53.98	2.27	1000.000	410.0	V	212.0	19

Test Personnel: Michael Carlson
Supervising/Reviewing Engineer: NA
(Where Applicable) FCC Part 15E
Product Standard: RSS-247 Issue 2
Input Voltage: 120VAC / 60Hz
Pretest Verification w / Ambient Signals or BB Source: Yes

Test Date: 6/4/2021 – 6/24/2021
Limit Applied: 15.407b
Ambient Temperature: 21.5 °C
Relative Humidity: 40.2 %
Atmospheric Pressure: 988.8 mbar

Deviations, Additions, or Exclusions: None

**15.6 Worst Case Radiated Spurious Emissions Data (802.11n, Channel 165)**

Frequency (MHz)	MaxPeak (dB μ V/m)	Limit (dB μ V/m)	Margin (dB)	Bandwidth (kHz)	Height (cm)	Pol	Azimuth (deg)	Corr. (dB/m)
3216.000000	45.53	88.23	42.70	1000.000	100.0	H	110.0	7
4531.500000	45.46	73.98	28.52	1000.000	220.0	V	102.0	9
4687.500000	47.00	73.98	26.98	1000.000	304.0	V	113.0	10
11650.000000	55.66	73.98	18.32	1000.000	193.0	V	243.0	19
14472.000000	53.06	73.98	20.92	1000.000	286.0	V	79.0	21

Frequency (MHz)	Average (dB μ V/m)	Limit (dB μ V/m)	Margin (dB)	Bandwidth (kHz)	Height (cm)	Pol	Azimuth (deg)	Corr. (dB/m)
3216.000000	39.19	68.23	29.04	1000.000	100.0	H	110.0	7
4531.500000	33.90	53.98	20.08	1000.000	220.0	V	102.0	9
4687.500000	36.79	53.98	17.19	1000.000	304.0	V	113.0	10
11650.000000	47.74	53.98	6.24	1000.000	193.0	V	243.0	19
14472.000000	40.71	53.98	13.27	1000.000	286.0	V	79.0	21

Test Personnel:	Michael Carlson	Test Date:	6/4/2021 – 6/24/2021
Supervising/Reviewing Engineer:		Limit Applied:	15.407b
(Where Applicable)	NA	Ambient Temperature:	21.5 °C
Product Standard:	FCC Part 15E	Relative Humidity:	40.2 %
Input Voltage:	RSS-247 Issue 2	Atmospheric Pressure:	988.8 mbar
Pretest Verification w / Ambient Signals or BB Source:	120VAC / 60Hz		
	Yes		

Deviations, Additions, or Exclusions: None

**15.7 Worst Case Radiated Spurious Emissions Data (802.11n (40MHz), Channel 151)**

Frequency (MHz)	QuasiPeak (dB μ V/m)	Limit (dB μ V/m)	Margin (dB)	Bandwidth (kHz)	Height (cm)	Pol	Azimuth (deg)	Corr. (dB/m)
124.952222	35.06	43.52	8.46	120.000	102.0	V	6.0	22
128.401111	30.47	43.52	13.05	120.000	400.0	V	230.0	22
256.225556	36.71	46.02	9.31	120.000	100.0	H	166.0	22
257.357222	36.10	46.02	9.92	120.000	105.0	H	171.0	22
275.086667	33.01	46.02	13.01	120.000	105.0	H	296.0	23
400.486111	34.75	46.02	11.27	120.000	105.0	V	265.0	26

Frequency (MHz)	MaxPeak (dB μ V/m)	Limit (dB μ V/m)	Margin (dB)	Bandwidth (kHz)	Height (cm)	Pol	Azimuth (deg)	Corr. (dB/m)
3216.000000	45.28	88.23	42.95	1000.000	100.0	H	110.0	7
4687.500000	46.58	73.98	27.40	1000.000	262.0	V	102.0	10
9648.000000	50.41	88.23	37.82	1000.000	193.0	V	92.0	17
11510.000000	53.58	73.98	20.40	1000.000	212.0	V	241.0	18
14472.000000	56.26	73.98	17.72	1000.000	219.0	V	92.0	21
19216.500000	58.06	73.98	15.92	1000.000	410.0	H	177.0	18
22526.000000	57.92	73.98	16.06	1000.000	396.0	H	0.0	11
23862.500000	58.81	73.98	15.17	1000.000	377.0	V	0.0	11
31828.000000	62.83	88.23	25.40	1000.000	100.0	H	332.0	17
36513.500000	65.20	88.23	23.03	1000.000	410.0	V	258.0	19

Frequency (MHz)	Average (dB μ V/m)	Limit (dB μ V/m)	Margin (dB)	Bandwidth (kHz)	Height (cm)	Pol	Azimuth (deg)	Corr. (dB/m)
3216.000000	39.23	68.23	29.00	1000.000	100.0	H	110.0	7
4687.500000	37.06	53.98	16.92	1000.000	262.0	V	102.0	10
9648.000000	39.22	68.23	29.01	1000.000	193.0	V	92.0	17
11510.000000	43.63	53.98	10.35	1000.000	212.0	V	241.0	18
14472.000000	46.62	53.98	7.36	1000.000	219.0	V	92.0	21
19216.500000	44.42	53.98	9.56	1000.000	410.0	H	177.0	18
22526.000000	44.75	53.98	9.23	1000.000	396.0	H	0.0	11
23862.500000	45.46	53.98	8.52	1000.000	377.0	V	0.0	11
31828.000000	49.30	68.23	18.93	1000.000	100.0	H	332.0	17
36513.500000	51.42	68.23	16.81	1000.000	410.0	V	258.0	19

Test Personnel: Michael Carlson
Supervising/Reviewing Engineer: NA
(Where Applicable) FCC Part 15E
Product Standard: RSS-247 Issue 2
Input Voltage: 120VAC / 60Hz
Pretest Verification w / Ambient Signals or BB Source: Yes

Test Date: 6/4/2021 – 6/24/2021
Limit Applied: 15.407b
Ambient Temperature: 21.5 °C
Relative Humidity: 40.2 %
Atmospheric Pressure: 988.8 mbar

Deviations, Additions, or Exclusions: None



15.8 Worst Case Radiated Spurious Emissions Data (802.11n (40MHz), Channel 159)

Frequency (MHz)	MaxPeak (dBµV/m)	Limit (dBµV/m)	Margin (dB)	Bandwidth (kHz)	Height (cm)	Pol	Azimuth (deg)	Corr. (dB/m)
3216.000000	45.10	88.23	43.13	1000.000	100.0	H	110.0	7
4687.500000	46.93	73.98	27.05	1000.000	262.0	V	103.0	10
9648.000000	49.63	88.23	38.60	1000.000	344.0	V	91.0	17
11590.000000	55.35	73.98	18.63	1000.000	212.0	V	240.0	19
14472.000000	55.52	73.98	18.46	1000.000	220.0	V	90.0	21

Frequency (MHz)	Average (dBµV/m)	Limit (dBµV/m)	Margin (dB)	Bandwidth (kHz)	Height (cm)	Pol	Azimuth (deg)	Corr. (dB/m)
3216.000000	39.02	68.23	29.21	1000.000	100.0	H	110.0	7
4687.500000	36.99	53.98	16.99	1000.000	262.0	V	103.0	10
9648.000000	37.32	68.23	30.91	1000.000	344.0	V	91.0	17
11590.000000	46.98	53.98	7.00	1000.000	212.0	V	240.0	19
14472.000000	45.98	53.98	8.00	1000.000	220.0	V	90.0	21

Test Personnel:	Michael Carlson	Test Date:	6/4/2021 – 6/24/2021
Supervising/Reviewing Engineer: (Where Applicable)	NA	Limit Applied:	15.407b
Product Standard:	FCC Part 15E	Ambient Temperature:	21.5 °C
Input Voltage:	RSS-247 Issue 2	Relative Humidity:	40.2 %
Pretest Verification w / Ambient Signals or BB Source:	120VAC / 60Hz	Atmospheric Pressure:	988.8 mbar
	Yes		

Deviations, Additions, or Exclusions: None



15.9 Worst Case Radiated Spurious Emissions Data (802.11n (80MHz), Channel 155)

Frequency (MHz)	QuasiPeak (dBµV/m)	Limit (dBµV/m)	Margin (dB)	Bandwidth (kHz)	Height (cm)	Pol	Azimuth (deg)	Corr. (dB/m)
124.952222	34.85	43.52	8.67	120.000	121.0	V	349.0	22
128.131667	30.10	43.52	13.42	120.000	194.0	V	224.0	22
256.279444	37.82	46.02	8.20	120.000	356.0	H	167.0	22
256.980000	34.40	46.02	11.62	120.000	354.0	H	176.0	22
278.266111	33.85	46.02	12.17	120.000	400.0	V	225.0	23

Frequency (MHz)	MaxPeak (dBµV/m)	Limit (dBµV/m)	Margin (dB)	Bandwidth (kHz)	Height (cm)	Pol	Azimuth (deg)	Corr. (dB/m)
3216.000000	45.03	88.23	43.20	1000.000	100.0	H	108.0	7
4687.500000	47.39	73.98	26.59	1000.000	292.0	V	104.0	10
6083.000000	49.83	88.23	38.40	1000.000	246.0	H	294.0	12
9648.000000	50.31	88.23	37.92	1000.000	308.0	V	95.0	17
11550.000000	55.96	73.98	18.02	1000.000	219.0	V	243.0	19
14472.000000	54.34	73.98	19.64	1000.000	281.0	V	81.0	21
18175.500000	57.45	73.98	16.53	1000.000	100.0	H	71.0	21
20097.000000	56.29	73.98	17.69	1000.000	275.0	V	0.0	15
31303.000000	61.28	73.98	12.70	1000.000	100.0	H	346.0	17
31587.500000	61.85	73.98	12.13	1000.000	410.0	V	283.0	17
36441.000000	64.44	73.98	9.54	1000.000	410.0	H	0.0	19
36480.000000	64.57	73.98	9.41	1000.000	410.0	V	0.0	19

Frequency (MHz)	Average (dBµV/m)	Limit (dBµV/m)	Margin (dB)	Bandwidth (kHz)	Height (cm)	Pol	Azimuth (deg)	Corr. (dB/m)
3216.000000	38.35	68.23	29.88	1000.000	100.0	H	108.0	7
4687.500000	38.02	53.98	15.96	1000.000	292.0	V	104.0	10
6083.000000	36.04	68.23	32.19	1000.000	246.0	H	294.0	12
9648.000000	37.97	68.23	30.26	1000.000	308.0	V	95.0	17
11550.000000	49.63	53.98	4.35	1000.000	219.0	V	243.0	19
14472.000000	42.79	53.98	11.19	1000.000	281.0	V	81.0	21
18175.500000	43.79	53.98	10.19	1000.000	100.0	H	71.0	21
20097.000000	42.98	53.98	11.00	1000.000	275.0	V	0.0	15
31303.000000	48.00	53.98	5.98	1000.000	100.0	H	346.0	17
31587.500000	48.79	53.98	5.19	1000.000	410.0	V	283.0	17
36441.000000	51.29	53.98	2.69	1000.000	410.0	H	0.0	19
36480.000000	50.95	53.98	3.03	1000.000	410.0	V	0.0	19

Test Personnel: Michael Carlson
Supervising/Reviewing Engineer: NA
(Where Applicable) FCC Part 15E
Product Standard: RSS-247 Issue 2
Input Voltage: 120VAC / 60Hz
Pretest Verification w / Ambient Signals or BB Source: Yes

Test Date: 6/4/2021 – 6/24/2021
Limit Applied: 15.407b
Ambient Temperature: 21.5 °C
Relative Humidity: 40.2 %
Atmospheric Pressure: 988.8 mbar

Deviations, Additions, or Exclusions: None

**16 Radiated Band Edge Emissions****16.1 Low Band Edge (U-NII-1, U-NII-2A)**

Frequency (MHz)	MaxPeak (dB μ V/m)	Limit (dB μ V/m)	Margin (dB)	Bandwidth (kHz)	Height (cm)	Pol	Azimuth (deg)	Corr. (dB/m)
5147.352000	69.73	74.00	4.27	1000.000	355.0	H	204.0	10
5149.020000	73.17	74.00	0.83	1000.000	300.0	H	208.0	10
5149.968000	69.92	74.00	4.08	1000.000	356.0	H	205.0	10

Frequency (MHz)	Average (dB μ V/m)	Limit (dB μ V/m)	Margin (dB)	Bandwidth (kHz)	Height (cm)	Pol	Azimuth (deg)	Corr. (dB/m)
5147.352000	49.20	54.00	4.80	1000.000	355.0	H	204.0	10
5149.020000	53.91	54.00	0.10	1000.000	300.0	H	208.0	10
5149.968000	52.36	54.00	1.64	1000.000	356.0	H	205.0	10

802.11a Channel 36

Frequency (MHz)	MaxPeak (dB μ V/m)	Limit (dB μ V/m)	Margin (dB)	Bandwidth (kHz)	Height (cm)	Pol	Azimuth (deg)	Corr. (dB/m)
5145.114000	67.87	74.00	6.13	1000.000	355.0	H	194.0	10
5146.722000	73.81	74.00	0.19	1000.000	377.0	H	205.0	10
5147.940000	70.20	74.00	3.80	1000.000	298.0	H	210.0	10
5149.488000	57.81	74.00	16.19	1000.000	218.0	V	295.0	10

Frequency (MHz)	MaxPeak (dB μ V/m)	Limit (dB μ V/m)	Margin (dB)	Bandwidth (kHz)	Height (cm)	Pol	Azimuth (deg)	Corr. (dB/m)
5145.114000	45.45	54.00	8.55	1000.000	355.0	H	194.0	10
5146.722000	49.76	54.00	4.24	1000.000	377.0	H	205.0	10
5147.940000	48.50	54.00	5.50	1000.000	298.0	H	210.0	10
5149.488000	38.01	54.00	15.99	1000.000	218.0	V	295.0	10

802.11n Channel 36



Frequency (MHz)	MaxPeak (dBµV/m)	Limit (dBµV/m)	Margin (dB)	Bandwidth (kHz)	Height (cm)	Pol	Azimuth (deg)	Corr. (dB/m)
5141.496000	70.61	74.00	3.39	1000.000	354.0	H	186.0	10
5144.748000	70.68	74.00	3.32	1000.000	278.0	H	223.0	10
5149.500000	70.24	74.00	3.76	1000.000	232.0	H	237.0	10

Frequency (MHz)	Average (dBµV/m)	Limit (dBµV/m)	Margin (dB)	Bandwidth (kHz)	Height (cm)	Pol	Azimuth (deg)	Corr. (dB/m)
5141.496000	52.72	54.00	1.28	1000.000	354.0	H	186.0	10
5144.748000	52.44	54.00	1.56	1000.000	278.0	H	223.0	10
5149.500000	53.49	54.00	0.51	1000.000	232.0	H	237.0	10

802.11n(40MHz) Channel 38

Frequency (MHz)	MaxPeak (dBµV/m)	Limit (dBµV/m)	Margin (dB)	Bandwidth (kHz)	Height (cm)	Pol	Azimuth (deg)	Corr. (dB/m)
5136.282000	66.56	74.00	7.44	1000.000	290.0	H	213.0	10
5141.208000	68.18	74.00	5.82	1000.000	361.0	H	192.0	10
5144.700000	67.72	74.00	6.28	1000.000	372.0	H	219.0	10
5149.584000	68.01	74.00	5.99	1000.000	355.0	H	214.0	10

Frequency (MHz)	Average (dBµV/m)	Limit (dBµV/m)	Margin (dB)	Bandwidth (kHz)	Height (cm)	Pol	Azimuth (deg)	Corr. (dB/m)
5136.282000	51.98	54.00	2.03	1000.000	290.0	H	213.0	10
5141.208000	53.25	54.00	0.75	1000.000	361.0	H	192.0	10
5144.700000	53.47	54.00	0.53	1000.000	372.0	H	219.0	10
5149.584000	52.98	54.00	1.02	1000.000	355.0	H	214.0	10

802.11n(80MHz) Channel 42

Test Personnel:	Michael Carlson	Test Date:	7/11/2021 – 7/27/2021
Supervising/Reviewing Engineer:	_____	Limit Applied:	15.407b
(Where Applicable)	NA	Ambient Temperature:	21.5 °C
	FCC Part 15E	Relative Humidity:	40.2 %
Product Standard:	RSS-247 Issue 2	Atmospheric Pressure:	988.8 mbar
Input Voltage:	120VAC / 60Hz		
Pretest Verification w / Ambient			
Signals or BB Source:	Yes		

Deviations, Additions, or Exclusions: None

**16.2 High Band Edge (U-NII-1, U-NII-2A)**

Frequency (MHz)	MaxPeak (dB μ V/m)	Limit (dB μ V/m)	Margin (dB)	Bandwidth (kHz)	Height (cm)	Pol	Azimuth (deg)	Corr. (dB/m)
5350.206000	69.49	73.98	4.49	1000.000	233.0	H	176.0	11
5351.662000	70.18	73.98	3.80	1000.000	325.0	H	218.0	11
5352.404000	67.82	73.98	6.16	1000.000	314.0	H	242.0	11
5353.846000	57.84	73.98	16.14	1000.000	276.0	H	162.0	11

Frequency (MHz)	Average (dB μ V/m)	Limit (dB μ V/m)	Margin (dB)	Bandwidth (kHz)	Height (cm)	Pol	Azimuth (deg)	Corr. (dB/m)
5350.206000	49.43	53.98	4.55	1000.000	233.0	H	176.0	11
5351.662000	53.24	53.98	0.74	1000.000	325.0	H	218.0	11
5352.404000	49.73	53.98	4.25	1000.000	314.0	H	242.0	11
5353.846000	41.09	53.98	12.89	1000.000	276.0	H	162.0	11

802.11a Channel 64

Frequency (MHz)	MaxPeak (dB μ V/m)	Limit (dB μ V/m)	Margin (dB)	Bandwidth (kHz)	Height (cm)	Pol	Azimuth (deg)	Corr. (dB/m)
5350.164000	73.38	73.98	0.60	1000.000	100.0	H	236.0	11
5352.866000	70.52	73.98	3.46	1000.000	306.0	H	195.0	11
5357.542000	64.85	73.98	9.13	1000.000	307.0	H	195.0	11
5360.797000	59.80	73.98	14.18	1000.000	307.0	H	196.0	11

Frequency (MHz)	Average (dB μ V/m)	Limit (dB μ V/m)	Margin (dB)	Bandwidth (kHz)	Height (cm)	Pol	Azimuth (deg)	Corr. (dB/m)
5350.164000	50.16	53.98	3.82	1000.000	100.0	H	236.0	11
5352.866000	50.22	53.98	3.76	1000.000	306.0	H	195.0	11
5357.542000	42.77	53.98	11.21	1000.000	307.0	H	195.0	11
5360.797000	40.59	53.98	13.38	1000.000	307.0	H	196.0	11

802.11n Channel 64



Frequency (MHz)	MaxPeak (dB μ V/m)	Limit (dB μ V/m)	Margin (dB)	Bandwidth (kHz)	Height (cm)	Pol	Azimuth (deg)	Corr. (dB/m)
5350.276000	63.48	73.98	10.50	1000.000	294.0	H	230.0	11
5354.343000	66.69	73.98	7.29	1000.000	370.0	H	186.0	11
5356.828000	64.18	73.98	9.79	1000.000	132.0	H	237.0	11
5359.026000	59.22	73.98	14.76	1000.000	158.0	H	237.0	11

Frequency (MHz)	Average (dB μ V/m)	Limit (dB μ V/m)	Margin (dB)	Bandwidth (kHz)	Height (cm)	Pol	Azimuth (deg)	Corr. (dB/m)
5350.276000	47.43	53.98	6.55	1000.000	294.0	H	230.0	11
5354.343000	48.58	53.98	5.40	1000.000	370.0	H	186.0	11
5356.828000	46.48	53.98	7.49	1000.000	132.0	H	237.0	11
5359.026000	40.26	53.98	13.72	1000.000	158.0	H	237.0	11

802.11n (40MHz) Channel 62

Frequency (MHz)	MaxPeak (dB μ V/m)	Limit (dB μ V/m)	Margin (dB)	Bandwidth (kHz)	Height (cm)	Pol	Azimuth (deg)	Corr. (dB/m)
5350.717000	67.70	73.98	6.28	1000.000	295.0	H	181.0	11
5356.198000	63.03	73.98	10.95	1000.000	163.0	H	236.0	11
5364.976000	65.99	73.98	7.99	1000.000	295.0	H	181.0	11
5376.071000	58.98	73.98	15.00	1000.000	169.0	H	182.0	11
5387.642000	59.85	73.98	14.13	1000.000	100.0	H	237.0	11

Frequency (MHz)	Average (dB μ V/m)	Limit (dB μ V/m)	Margin (dB)	Bandwidth (kHz)	Height (cm)	Pol	Azimuth (deg)	Corr. (dB/m)
5350.717000	52.99	53.98	0.99	1000.000	295.0	H	181.0	11
5356.198000	48.09	53.98	5.89	1000.000	163.0	H	236.0	11
5364.976000	50.97	53.98	3.01	1000.000	295.0	H	181.0	11
5376.071000	44.13	53.98	9.85	1000.000	169.0	H	182.0	11
5387.642000	43.06	53.98	10.92	1000.000	100.0	H	237.0	11

802.11n (80MHz) Channel 58

Test Personnel:	Michael Carlson	Test Date:	7/11/2021 – 7/27/2021
Supervising/Reviewing Engineer: (Where Applicable)	NA	Limit Applied:	15.407b
Product Standard:	FCC Part 15E	Ambient Temperature:	21.5 °C
Input Voltage:	RSS-247 Issue 2	Relative Humidity:	40.2 %
Pretest Verification w / Ambient Signals or BB Source:	120VAC / 60Hz	Atmospheric Pressure:	988.8 mbar
	Yes		

Deviations, Additions, or Exclusions: None

**16.3 Low Band Edge (U-NII-2C)**

Frequency (MHz)	MaxPeak (dB μ V/m)	Limit (dB μ V/m)	Margin (dB)	Bandwidth (kHz)	Height (cm)	Pol	Azimuth (deg)	Corr. (dB/m)
5457.530000	64.50	73.98	9.48	1000.000	377.0	H	222.0	10
5461.460000	47.99	88.23	40.24	1000.000	236.0	H	342.0	10
5465.114000	73.40	88.23	14.83	1000.000	378.0	H	222.0	10
5467.310000	76.82	88.23	11.41	1000.000	378.0	H	223.0	10
5469.038000	74.36	88.23	13.87	1000.000	280.0	H	242.0	10

Frequency (MHz)	Average (dB μ V/m)	Limit (dB μ V/m)	Margin (dB)	Bandwidth (kHz)	Height (cm)	Pol	Azimuth (deg)	Corr. (dB/m)
5457.530000	44.75	53.98	9.23	1000.000	377.0	H	222.0	10
5461.460000	34.81	68.23	33.42	1000.000	236.0	H	342.0	10
5465.114000	53.10	68.23	15.13	1000.000	378.0	H	222.0	10
5467.310000	56.98	68.23	11.25	1000.000	378.0	H	223.0	10
5469.038000	57.06	68.23	11.17	1000.000	280.0	H	242.0	10

802.11a Channel 100

Frequency (MHz)	MaxPeak (dB μ V/m)	Limit (dB μ V/m)	Margin (dB)	Bandwidth (kHz)	Height (cm)	Pol	Azimuth (deg)	Corr. (dB/m)
5457.620000	53.24	73.98	20.74	1000.000	246.0	V	320.0	10
5459.060000	72.32	73.98	1.66	1000.000	410.0	H	194.0	10
5459.546000	67.54	73.98	6.44	1000.000	364.0	V	251.0	10
5466.512000	75.85	88.23	12.38	1000.000	381.0	V	251.0	10
5468.870000	77.80	88.23	10.43	1000.000	368.0	H	191.0	10

Frequency (MHz)	Average (dB μ V/m)	Limit (dB μ V/m)	Margin (dB)	Bandwidth (kHz)	Height (cm)	Pol	Azimuth (deg)	Corr. (dB/m)
5457.620000	40.19	53.98	13.79	1000.000	246.0	V	320.0	10
5459.060000	50.62	53.98	3.36	1000.000	410.0	H	194.0	10
5459.546000	45.70	53.98	8.28	1000.000	364.0	V	251.0	10
5466.512000	56.29	68.23	11.94	1000.000	381.0	V	251.0	10
5468.870000	59.47	68.23	8.76	1000.000	368.0	H	191.0	10

802.11n Channel 100



Frequency (MHz)	MaxPeak (dBμV/m)	Limit (dBμV/m)	Margin (dB)	Bandwidth (kHz)	Height (cm)	Pol	Azimuth (deg)	Corr. (dB/m)
5453.714000	70.94	73.98	3.04	1000.000	365.0	H	173.0	10
5459.090000	64.68	73.98	9.30	1000.000	218.0	V	308.0	10
5461.022000	68.19	88.23	20.04	1000.000	115.0	V	306.0	10
5462.900000	68.58	88.23	19.65	1000.000	189.0	V	310.0	10
5464.274000	78.80	88.23	9.43	1000.000	381.0	V	327.0	10
5469.548000	72.84	88.23	15.39	1000.000	228.0	V	311.0	10

Frequency (MHz)	Average (dBμV/m)	Limit (dBμV/m)	Margin (dB)	Bandwidth (kHz)	Height (cm)	Pol	Azimuth (deg)	Corr. (dB/m)
5453.714000	48.70	53.98	5.28	1000.000	365.0	H	173.0	10
5459.090000	46.20	53.98	7.78	1000.000	218.0	V	308.0	10
5461.022000	49.75	68.23	18.48	1000.000	115.0	V	306.0	10
5462.900000	51.04	68.23	17.19	1000.000	189.0	V	310.0	10
5464.274000	61.54	68.23	6.69	1000.000	381.0	V	327.0	10
5469.548000	57.98	68.23	10.25	1000.000	228.0	V	311.0	10

802.11n (40MHz) Channel 102

Frequency (MHz)	MaxPeak (dBμV/m)	Limit (dBμV/m)	Margin (dB)	Bandwidth (kHz)	Height (cm)	Pol	Azimuth (deg)	Corr. (dB/m)
5454.266000	66.33	73.98	7.65	1000.000	273.0	H	192.0	10
5458.568000	68.10	73.98	5.88	1000.000	359.0	H	242.0	10
5459.816000	64.47	73.98	9.51	1000.000	272.0	H	190.0	10
5463.590000	65.60	88.23	22.63	1000.000	273.0	H	192.0	10
5469.482000	67.24	88.23	20.99	1000.000	399.0	H	192.0	10

Frequency (MHz)	Average (dBμV/m)	Limit (dBμV/m)	Margin (dB)	Bandwidth (kHz)	Height (cm)	Pol	Azimuth (deg)	Corr. (dB/m)
5454.266000	51.14	53.98	2.84	1000.000	273.0	H	192.0	10
5458.568000	52.19	53.98	1.79	1000.000	359.0	H	242.0	10
5459.816000	50.26	53.98	3.72	1000.000	272.0	H	190.0	10
5463.590000	51.66	68.23	16.57	1000.000	273.0	H	192.0	10
5469.482000	53.85	68.23	14.38	1000.000	399.0	H	192.0	10

802.11n (80MHz) Channel 106

Test Personnel:	Michael Carlson	Test Date:	7/11/2021 – 7/27/2021
Supervising/Reviewing Engineer:		Limit Applied:	15.407b
(Where Applicable)	NA	Ambient Temperature:	21.5 °C
Product Standard:	FCC Part 15E	Relative Humidity:	40.2 %
Input Voltage:	RSS-247 Issue 2	Atmospheric Pressure:	988.8 mbar
Pretest Verification w / Ambient Signals or BB Source:	120VAC / 60Hz		
	Yes		

Deviations, Additions, or Exclusions: None

**16.4 High Band Edge (U-NII-3)**

Frequency (MHz)	MaxPeak (dB μ V/m)	Limit (dB μ V/m)	Margin (dB)	Bandwidth (kHz)	Height (cm)	Pol	Azimuth (deg)	Corr. (dB/m)
5850.928000	89.25	140.11	50.87	1000.000	294.0	H	228.0	12
5861.008000	83.78	129.15	45.37	1000.000	286.0	H	284.0	12
5923.200000	52.29	89.56	37.27	1000.000	304.0	V	300.0	11

Frequency (MHz)	Average (dB μ V/m)	Limit (dB μ V/m)	Margin (dB)	Bandwidth (kHz)	Height (cm)	Pol	Azimuth (deg)	Corr. (dB/m)
5850.928000	75.29	120.11	44.83	1000.000	294.0	H	228.0	12
5861.008000	65.84	109.15	43.31	1000.000	286.0	H	284.0	12
5923.200000	39.39	69.56	30.17	1000.000	304.0	V	300.0	11

802.11a Channel 165

Frequency (MHz)	MaxPeak (dB μ V/m)	Limit (dB μ V/m)	Margin (dB)	Bandwidth (kHz)	Height (cm)	Pol	Azimuth (deg)	Corr. (dB/m)
5856.599000	88.42	130.38	41.96	1000.000	283.0	H	52.0	12
5926.163000	53.13	88.23	35.10	1000.000	110.0	H	176.0	11

Frequency (MHz)	Average (dB μ V/m)	Limit (dB μ V/m)	Margin (dB)	Bandwidth (kHz)	Height (cm)	Pol	Azimuth (deg)	Corr. (dB/m)
5856.599000	71.26	110.38	39.12	1000.000	283.0	H	52.0	12
5926.163000	41.22	68.23	27.01	1000.000	110.0	H	176.0	11

802.11n Channel 165



Frequency (MHz)	MaxPeak (dBμV/m)	Limit (dBμV/m)	Margin (dB)	Bandwidth (kHz)	Height (cm)	Pol	Azimuth (deg)	Corr. (dB/m)
5854.553000	80.72	131.85	51.13	1000.000	185.0	H	182.0	12
5887.256000	72.18	116.16	43.98	1000.000	393.0	H	200.0	12
5910.356000	70.68	99.07	28.39	1000.000	378.0	H	200.0	11

Frequency (MHz)	Average (dBμV/m)	Limit (dBμV/m)	Margin (dB)	Bandwidth (kHz)	Height (cm)	Pol	Azimuth (deg)	Corr. (dB/m)
5854.553000	64.37	111.85	47.48	1000.000	185.0	H	182.0	12
5887.256000	53.23	96.16	42.93	1000.000	393.0	H	200.0	12
5910.356000	49.36	79.07	29.71	1000.000	378.0	H	200.0	11

802.11n (40MHz) Channel 165

Frequency (MHz)	MaxPeak (dBμV/m)	Limit (dBμV/m)	Margin (dB)	Bandwidth (kHz)	Height (cm)	Pol	Azimuth (deg)	Corr. (dB/m)
5863.100000	87.05	128.56	41.51	1000.000	374.0	H	196.0	12
5904.251000	79.69	103.58	23.90	1000.000	273.0	H	192.0	12
5927.230000	77.38	88.23	10.85	1000.000	274.0	H	192.0	11
5942.300000	73.53	88.23	14.70	1000.000	273.0	H	192.0	11

Frequency (MHz)	Average (dBμV/m)	Limit (dBμV/m)	Margin (dB)	Bandwidth (kHz)	Height (cm)	Pol	Azimuth (deg)	Corr. (dB/m)
5863.100000	74.22	108.56	34.34	1000.000	374.0	H	196.0	12
5904.251000	65.91	83.58	17.67	1000.000	273.0	H	192.0	12
5927.230000	61.57	68.23	6.66	1000.000	274.0	H	192.0	11
5942.300000	57.96	68.23	10.27	1000.000	273.0	H	192.0	11

802.11n (80MHz) Channel 155

Test Personnel:	Michael Carlson	Test Date:	7/11/2021 – 7/27/2021
Supervising/Reviewing Engineer:	NA	Limit Applied:	15.407b
(Where Applicable)	FCC Part 15E	Ambient Temperature:	21.5 °C
Product Standard:	RSS-247 Issue 2	Relative Humidity:	40.2 %
Input Voltage:	120VAC / 60Hz	Atmospheric Pressure:	988.8 mbar
Pretest Verification w / Ambient Signals or BB Source:	Yes		

Deviations, Additions, or Exclusions: None



17 Revision History

Revision Level	Date	Report Number	Prepared By	Reviewed By	Notes
0	10/7/2021	104962659LEX-005	BCT	BZ	Original Issue
1	12/17/2021	104962659LEX-005.1	BCT	BZ	Removed the DFS bands for U-NII-2A and U-NII-2C
2	3/1/2022	104626259LEX-005.2	BZ	JTS	Updated output power
3	3/1/2022	104626259LEX-005.3	BZ	JTS	Added the DFS bands for U-NII-2A and U-NII-2C