

FCC - TEST REPORT

Report Number : **64.790.18.04286.01-2** Date of Issue: 2018-11-30

Model : **D04012**

Product Type : Smart Access Point Pro

Applicant : ABB Genway Xiamen Electrical Equipment Co.,Ltd

Manufacturer : ABB Genway Xiamen Electrical Equipment Co.,Ltd

Address : No.7 Fangshan South Road, Torch High Technology,Development Zone (Xiang An), Industrial Zone, 361000 Xiamen S.E.Z, Fujian Province, PEOPLE'S REPUBLIC OF CHINA

Test Result : **Positive** **Negative**



Total pages including Appendices : **32**

TÜV SÜD Certification and Testing (China) Co., Ltd. Guangzhou Branch is a subcontractor to TÜV SÜD Product Service GmbH according to the principles outlined in ISO 17025.

TÜV SÜD Certification and Testing (China) Co., Ltd. Guangzhou Branch reports apply only to the specific samples tested under stated test conditions. Construction of the actual test samples has been documented. It is the manufacturer's responsibility to assure that additional production units of this model are manufactured with identical electrical and mechanical components. The manufacturer/importer is responsible to the Competent Authorities in Europe for any modifications made to the production units which result in non-compliance to the relevant regulations. TÜV SÜD Certification and Testing (China) Co., Ltd. Guangzhou Branch shall have no liability for any deductions, inferences or generalizations drawn by the client or others from TÜV SÜD Certification and Testing (China) Co., Ltd. Guangzhou Branch issued reports.

This report is the confidential property of the client. As a mutual protection to our clients, the public and ourselves, extracts from the test report shall not be reproduced except in full without our written approval

1. Table of Contents

1.	TABLE OF CONTENTS.....	2
2.	DETAILS ABOUT THE TEST LABORATORY.....	3
3.	SUMMARY OF TEST STANDARDS.....	6
4.	SUMMARY OF TEST RESULTS.....	7
5.	GENERAL REMARKS.....	8
6.	TECHNICAL REQUIREMENT.....	9
8.1.	Conducted Emission.....	9
8.2.	Emission bandwidth.....	12
8.3.	Maximum conducted output power.....	14
8.4.	Maximum power spectral density.....	15
8.5.	Unwanted emissions.....	17
8.6.	Band Edge.....	25
8.7.	Frequencies Stability.....	26
8.8.	Dynamic Frequency Selection (DFS).....	27
7.	TEST EQUIPMENT LIST.....	31
8.	SYSTEM MEASUREMENT UNCERTAINTY.....	32



2. Details about the Test Laboratory

Details about the Test Laboratory

Test Site 1

Company name: TÜV SÜD Certification and Testing (China) Co., Ltd. Shenzhen Branch
Building 12&13, Zhiheng Wisdomland Business Park,
Nantou Checkpoint Road 2, Nanshan District,
Shenzhen City, 518052,
P. R. China

FCC Registration Number: 514049

IC Registration No: 10320A-1

Telephone: 86 755 8828 6998

Fax: 86 755 8828 5299

3. Description of the Equipment Under Test

Product:	Smart Access Point Pro
Model no.:	D04012
FCC ID:	2AEBL-D04012
Options and accessories:	NIL
Rating:	DC 24V
RF Transmission Frequency:	5180-5240MHz, 5260-5320MHz, 5500-5700MHz, 5745-5825MHz
Modulation:	802.11a: BPSK, QPSK, 16QAM, 64QAM 802.11n: BPSK, QPSK, 16QAM, 64QAM 802.11a: BPSK, QPSK, 16QAM, 64QAM
Antenna Type:	Integral Antenna
Antenna Gain:	4.2dBi for 5G WIFI
Description of the EUT:	The Equipment Under Test (EUT) is a Smart Access Point Pro with WIFI function operated at 2.4G/5GHz.

Auxiliary Equipment Used during Test:

DESCRIPTION	MODEL NO.(SHIELD)	MANUFACTURER
Laptop	T460S	LENOVO
IP touch 7, LAN + Wireless, with induction loop	H82364-.	ABB
Interface module	52361EX	ABB
ABB Welcome IP pushbutton video outdoor station	H81381P.-.	ABB
ABB Welcome IP keypad video outdoor station	H8138.K.-.	ABB
ABB Welcome IP touch 5" video outdoor station	H8138.T.-.	ABB
Outdoor station A/V module	H85138.M-S	ABB
Outdoor station touch 5" module	H85138.DP	ABB
Outdoor station Bar pushbutton module	5138.SP.	ABB
Outdoor station Round pushbutton module	5138.RP.	ABB
Outdoor station keypad module	5138.K.-.	ABB
IP Actuator	H8304	ABB
Guard unit	H8303	ABB
System controller	YSM01	ABB
POE Switch	TL-SL1218P	TP-LINK

Test software information:

Test Software Version	TI_Wireless_Tools_3.0.2.1		
Modulation	Setting TX Power	Mode	Packet Type
802.11a	17	Continuous	6 Mbps
802.11n HT20	17	Continuous	MCS0 Mbps
802.11n HT40	17	Continuous	MCS0 Mbps

Test channel:

Test Mode	Channel (MHz)		
802.11a, 802.11n HT20	5G WIFI-Band 1		
	CH36 (5180MHz)	CH40 (5200MHz)	CH46 (5240MHz)
	5G WIFI-Band 2		
	CH52 (5260MHz)	CH56 (5280MHz)	CH64 (5320MHz)
	5G WIFI-Band 3		
	CH100 (5500MHz)	CH116 (5580MHz)	CH140 (5700MHz)
	CH 142 (5710MHz)		
	5G WIFI-Band 4		
	CH149 (5745MHz),	CH157(5785MHz)	CH165 (5825MHz)

Test Mode	Channel (MHz)		
802.11n HT40	5G WIFI-Band 1		
	CH38(5190MHz)	CH46 (5230MHz)	
	5G WIFI-Band 2		
	CH54(5270MHz)	CH62(5310MHz)	
	5G WIFI-Band 3		
	CH102(5510MHz)	CH110(5550MHz)	CH134(5670MHz)
	CH 144 (5720MHz)		
	5G WIFI-Band 4		
	CH151(5755MHz)	CH159(5795MHz)	

Note: According to FCC KDB 789033 D02 General UNII Test Procedures New Rules v02r01, Channels: CH 142 (5710MHz) and CH 144 (5720MHz) were chose to perform Conducted output power and emission bandwidth testing.

4. Summary of Test Standards

Test Standards	
FCC Part 15 Subpart E, 10-1-2017 Edition	PART 15 - RADIO FREQUENCY DEVICES Subpart E - Unlicensed National Information Infrastructure Devices

Test Method:

- 1: ANSI C63.10-2013, American National Standard for Testing Unlicensed Wireless Devices.
- 2: KDB 789033 D02 General UNII Test Procedures New Rules v02r01
- 3: KDB 905462 D02 UNII DFS Compliance Procedures New Rules v02

5. Summary of Test Results

Technical Requirements			
FCC Part 15 Subpart E,			
Test Condition	Test Result	Verdict	Test Site
15.207 Conducted Emission AC Power Port	See Page 11-12	Pass	Site 1
15.407(e) Emission bandwidth	Appendix A1-A3	Pass	Site 1
15.407(a)(i) Maximum Conducted Output Power	Appendix B	Pass	Site 1
15.407(a)(i) Maximum Power Spectral Density	Appendix C	Pass	Site 1
15.407(b)(1), 15.407(b)(2), 15.407(b)(3), 15.407(b)(4), 15.407(b)(6) 15.407(b)(7) 15.209 Unwanted Emissions (Conducted)	Appendix E	Pass	Site 1
15.407(b)(1), 15.407(b)(2), 15.407(b)(3), 15.407(b)(4), 15.407(b)(6) 15.407(b)(7) 15.209 Unwanted Emissions (Radiated)	See Page 20-23	Pass	Site 1
15.407(b)(i), 15.407(b)(5), 15.407(b)(7), 15.209 Band edge compliance	Appendix D	Pass	Site 1
15.407(g) Frequencies Stability	Appendix F	Pass	Site 1
15.407(h) Dynamic Frequency Selection (DFS). ^a	Appendix G	Pass	Site 1
15.203 Antenna Requirement ^b	See note b	Pass	Site 1

Remark: ^a The EUT is Clients Device without Radar Detection.

Remark: ^b anIntegrated Antenna,the antenna gain: 4.2dBi

6. General Remarks

Remarks

This submittal(s) (test report) is intended for FCC ID:2AEBL-D04012, complies with Section 15.207, 15.209, 15.205 of the FCC Part 15, Subpart C, Subpart E rules.

The Model: D04012 supports Wi-Fi functions, 2412MHz - 2462MHz for 2.4GHz Wi-Fi, 5180MHz – 5320MHz, 5500MHz – 5700MHz, 5745MHz – 5825MHz for 5GHz Wi-Fi.

This report is for the 5GHz Wi-Fi.

SUMMARY:

All tests according to the regulations cited on page 5 were

- Performed

- **Not** Performed

The Equipment Under Test

- **Fulfills** the general approval requirements.

- **Does not** fulfill the general approval requirements.

Sample Received Date: 2018-07-10

Testing Start Date: 2018-07-13

Testing End Date: 2018-07-17

TÜV SÜD Certification and Testing (China) Co., Ltd. Guangzhou Branch

Reviewed by:

Prepared by:



Tony Liu



Kevin Ouyang

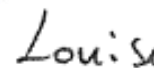

Louise Liu

7. Technical Requirement

8.1. Conducted Emission

Test Method:

1. The EUT was placed on a table, which is 0.8m above ground plane.
2. The power line of the EUT is connected to the AC mains through an Artificial Mains Network (A.M.N.).
3. Maximum procedure was performed to ensure EUT compliance.
4. A EMI test receiver is used to test the emissions from both sides of AC line.

Test Setup:

The mains cable of the EUT (per AC/DC Adapter) must be connected to LISN. The LISN shall be placed 0.8 m from the boundary of EUT and bonded to a ground reference plane for LISN mounted on top of the ground reference plane. This distance is between the closest points of the LISN and the EUT. All other units of the EUT and associated equipment shall be at least 0.8m from the LISN.

Ground connections, where required for safety purposes, shall be connected to the reference ground point of the LISN and, where not otherwise provided or specified by the manufacturer, shall be of same length as the mains cable and run parallel to the mains connection at a separation distance of not more than 0.1 m.

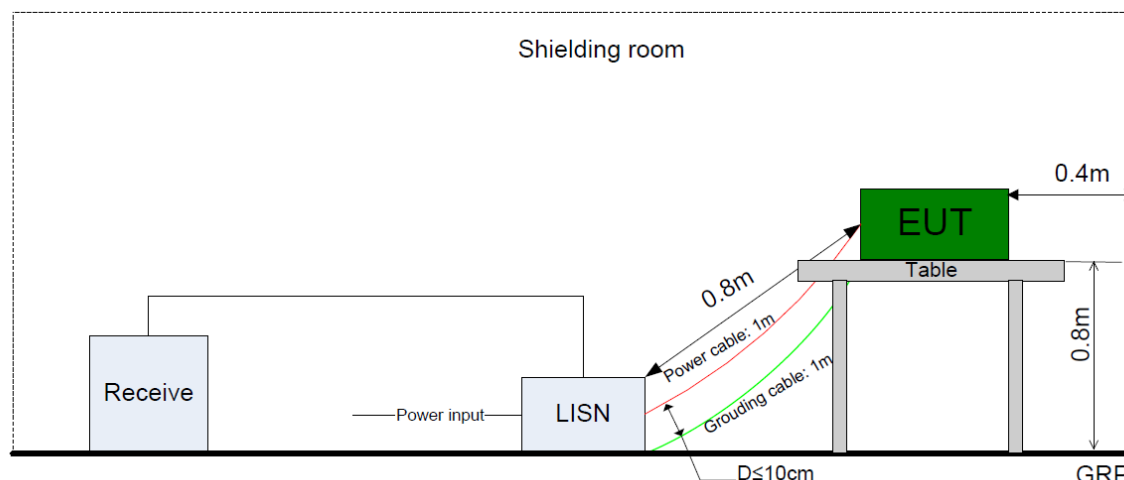

Limit:

Frequency MHz	QP Limit dB μ V	AV Limit dB μ V
0.150-0.500	66-56*	56-46*
0.500-5	56	46
5-30	60	50

Decreasing linear

Test Result: Pass

Test data:

Conducted Emission

Operating Condition : WiFi function on.
Test Specification : L
Comment : AC 120V/60Hz
Test date : 2018-07-11

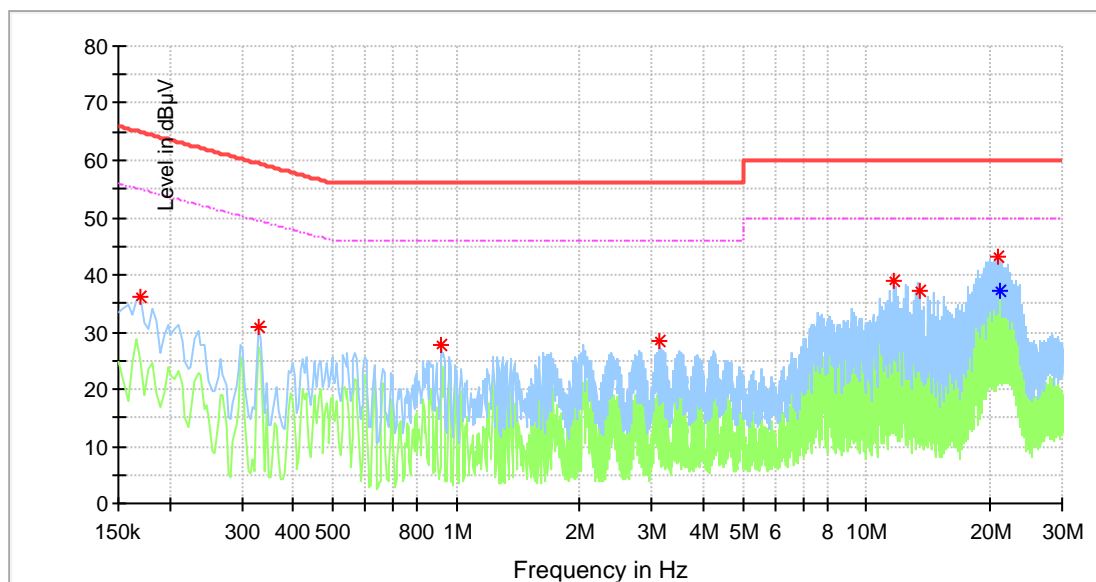

No significant emission was detected within 10 dB to limit

Conducted Emission

Product Type : IP touch 7"
Operating Condition : WiFi function on.
Test Specification : N
Comment : AC 120V/60Hz
Test date : 2018-07-11

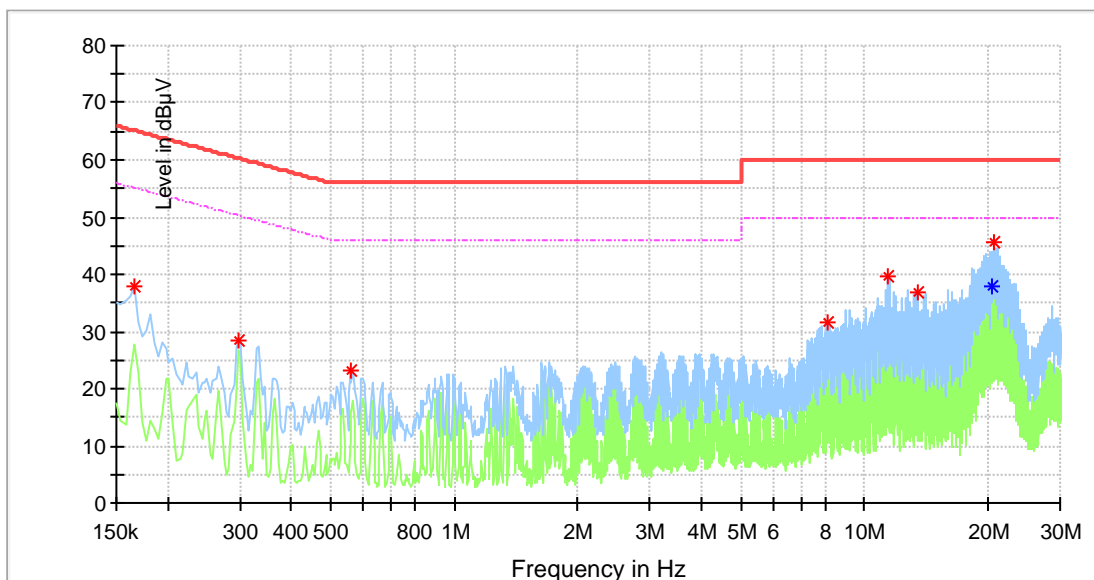

No significant emission was detected within 10 dB to limit

8.2. Emission bandwidth

Test Method of 26dB Bandwidth

According to KDB789033 D02

- a) Set RBW = approximately 1% of the emission bandwidth.
- b) Set the VBW > RBW.
- c) Detector = Peak.
- d) Trace mode = max hold.
- e) Measure the maximum width of the emission that is 26 dB down from the maximum of the emission. Compare this with the RBW setting of the analyzer. Readjust RBW and repeat measurement as needed until the RBW/EBW ratio is approximately 1%.

Limit: No limit

Test Method of 6dB Bandwidth

According to KDB789033 D02

- a) Set RBW = 100KHz
- b) Set the video bandwidth (VBW) $\geq 3 \times$ RBW
- c) Detector = Peak.
- d) Trace mode = max hold.
- e) Sweep = auto couple.
- f) Allow the trace to stabilize.
- g) Measure the maximum width of the emission that is constrained by the frequencies associated with the two outermost amplitude points (upper and lower frequencies) that are attenuated by 6 dB relative to the maximum level measured in the fundamental emission.

Limit: ≥ 500 KHz

Test Method of 99% Bandwidth

According to KDB789033 D02

- a) Set center frequency to the nominal EUT channel center frequency
- b) Set span = 1.5 times to 5.0 times the OBW.
- c) Set RBW = 1 % to 5 % of the OBW
- d) Set VBW $\geq 3 \cdot$ RBW
- e) Video averaging is not permitted. Where practical, a sample detection and single sweep mode shall be used. Otherwise, peak detection and max hold mode (until the trace stabilizes) shall be used.
- f) Use the 99 % power bandwidth function of the instrument (if available).
- g) If the instrument does not have a 99 % power bandwidth function, the trace data points are recovered and directly summed in power units. The recovered amplitude data points, beginning at the lowest frequency, are placed in a running sum until 0.5 % of the total is reached; that frequency is recorded as the lower frequency. The process is repeated until 99.5 % of the total is reached; that frequency is recorded as the upper frequency. The 99% occupied bandwidth is the difference between these two frequencies.

Test Setup:

The Wi-Fi component's antenna ports(s) of the EUT are connected to the measurement instrument per an appropriate attenuator. The EUT is controlled by PC/software to emit the specified signals for the purpose of measurements.

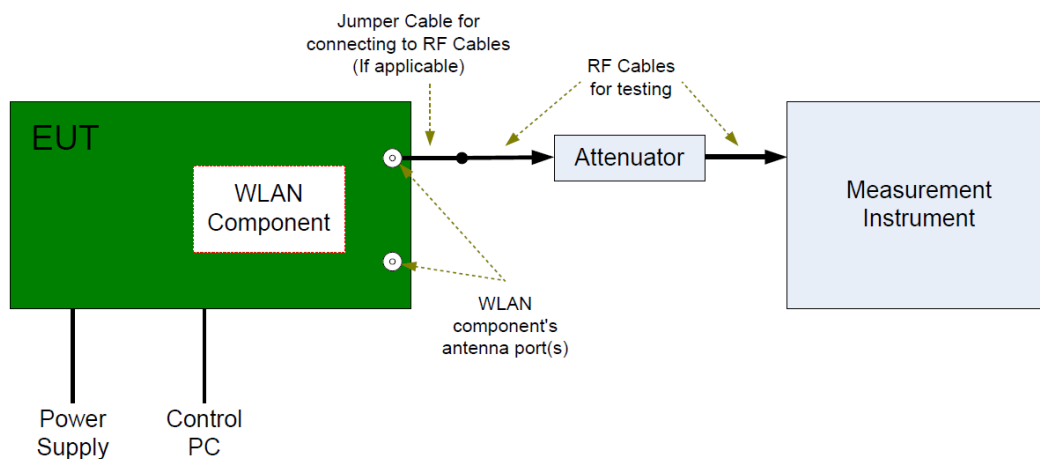

Limit: No limit.

Test Result: Pass

8.3. Maximum conducted output power

Test Method:

According to KDB789033 D02

1. Connect EUT test port to Power meter. Set the EUT to transmit maximum output power at 5GHz Band 1/2/3/4.
2. Then set the EUT to transmit at high, middle and low frequency and measure the conducted output power separately.
3. Repeat above procedures until all frequencies measured were complete.

Limits:

The maximum conducted output power over the frequency band of operation shall not exceed 1W for 5.15-5.25GHz Band, 250mW for 5.25-5.35GHz, 5.47-5.725 GHz Band and 1W for 5.725-5.85GHz Band, provided the maximum antenna gain does not exceed 6dBi.

Note:

1. Maximum Conducted Output Power = Conducted Average Output Power + Correction Factor (cable loss & duty cycle correction)
2. EIRP = Maximum Conducted Output Power + ANT Gain

Test Setup:

The Wi-Fi component's antenna ports(s) of the EUT are connected to the measurement instrument per an appropriate attenuator. The EUT is controlled by PC/software to emit the specified signals for the purpose of measurements.

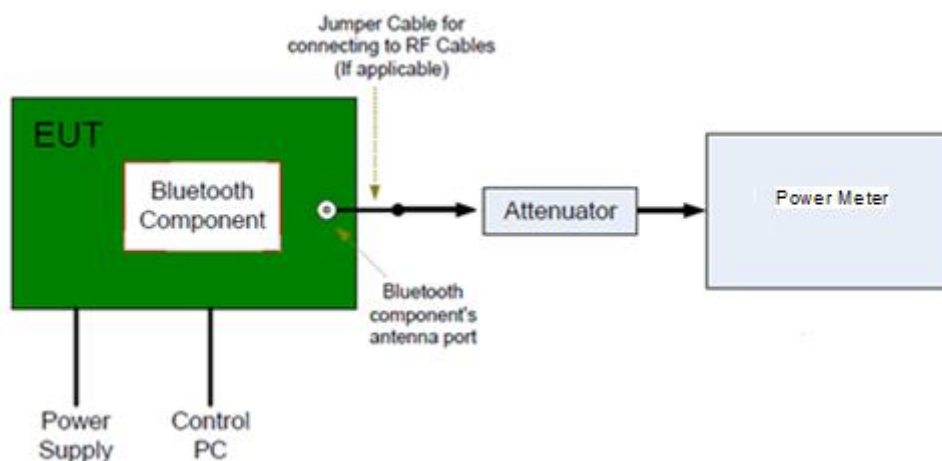

Test Result: Pass

8.4. Maximum power spectral density

Test Method

According to KDB789033 D02

For devices operating in the bands 5.15-5.25 GHz, 5.25-5.35 GHz, and 5.47-5.725 GHz, the above procedures make use of 1 MHz RBW to satisfy directly the 1 MHz reference bandwidth specified in § 15.407(a)(5). For devices operating in the band 5.725-5.85 GHz, the rules specify a measurement bandwidth of 500 kHz. Many spectrum analyzers do not have 500 kHz RBW, thus a narrower RBW may need to be used. The rules permit the use of a RBWs less than 1 MHz, or bandwidth” to show the total power over the specified measurement bandwidth (i.e., 1 MHz, or 500 kHz). If measurements are performed using a reduced resolution bandwidth (< 1 MHz, or < 500 kHz) and integrated over 1 MHz, or 500 KHz bandwidth, the following adjustments to the procedures apply:

- a) Set $RBW \geq 1/T$, where T is defined in section II.B.I.a).
- b) Set $VBW \geq 3 RBW$.
- c) If measurement bandwidth of Maximum PSD is specified in 500 kHz, add $10\log(500\text{kHz}/RBW)$ to the measured result, whereas RBW (< 500 KHz) is the reduced resolution bandwidth of the spectrum analyzer set during measurement.
- d) If measurement bandwidth of Maximum PSD is specified in 1 MHz, add $10\log(1\text{MHz}/RBW)$ to the measured result, whereas RBW (< 1 MHz) is the reduced resolution bandwidth of spectrum analyzer set during measurement.
- e) Care must be taken to ensure that the measurements are performed during a period of continuous transmission or are corrected upward for duty cycle.

Note: As a practical matter, it is recommended to use reduced RBW of 100 KHz for the sections 5.c) and 5.d) above, since RBW=100 KHz is available on nearly all spectrum analyzers.

Limit: The maximum power spectral density shall not exceed 11dBm for the 5.15-5.25GHz, 5.25-5.35GHz, 5.47-5.725 GHz Band and 30dBm for the 5.8GHz Band in any 1 megahertz band.

Test Setup:

The Wi-Fi component's antenna ports(s) of the EUT are connected to the measurement instrument per an appropriate attenuator. The EUT is controlled by PC/software to emit the specified signals for the purpose of measurements.

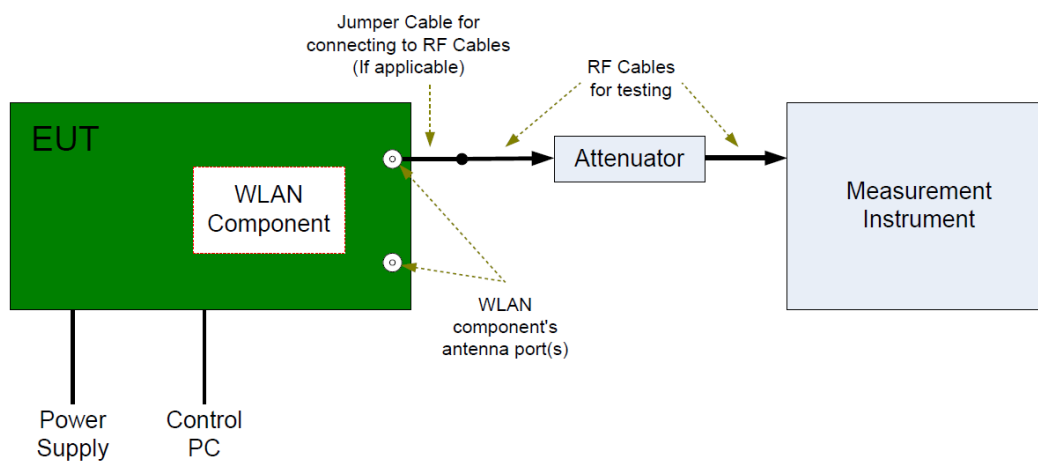

Test Result: Pass

8.5. Unwanted emissions

Radiated:

Test Method

1: The EUT was placed on a turn table which is 1.5m above ground plane for above 1GHz and 0.8m above ground for below 1GHz at 3meter chamber room for test. The table was rotated 360 degrees to determine the position of the highest radiation.

2: The EUT was set 3 meters away from the interference – receiving antenna, which was mounted on the top of a variable – height antenna tower.

3: The height of antenna is varied from one meter to four meters above the ground to determine the maximum value of the field strength. Both horizontal and vertical polarizations of the antenna are set to make the measurement.

4: For each suspected emission, the EUT was arranged to its worst case and then the antenna was tuned to heights from 1 meter to 4 meters and the rotatable table was turned from 0 degrees to 360 degrees to find the maximum reading.

5: Use the following spectrum analyzer settings According to C63.10:

For Above 1GHz

Span = wide enough to capture the peak level of the in-band emission and all spurious
RBW = 1MHz, VBW \geq RBW for peak measurement and VBW = 10Hz for average measurement, Sweep = auto, Detector function = peak, Trace = max hold.

For Below 1GHz

Use the following spectrum analyzer settings:

Span = wide enough to capture the peak level of the in-band emission and all spurious
RBW = 100 KHz, VBW \geq RBW for peak measurement, Sweep = auto, Detector function = peak, Trace = max hold.

For Below 30MHz

Use the following spectrum analyzer settings:

Span = wide enough to capture the peak level of the in-band emission and all spurious
RBW = 200 Hz, VBW \geq RBW from 9KHz to 0.15MHz, RBW 9KHz VBW \geq RBW from 0.15MHz to 30MHz for peak measurement, Sweep = auto, Detector function = peak, Trace = max hold.

Note:

1: The resolution bandwidth and video bandwidth of test receiver/spectrum analyzer is 120 KHz for Quasi-peak detection (QP) at frequency below 1GHz.

2: The resolution bandwidth of test receiver/spectrum analyzer is 1MHz and the video bandwidth is 3MHz for peak detection (PK) at frequency above 1GHz.

3: The resolution bandwidth of test receiver/spectrum analyzer is 1MHz and the video bandwidth is 3MHz for RMS Average ((duty cycle < 98%) for Average detection (AV) at frequency above 1GHz, then the measurement results was added to a correction factor (20log(1/duty cycle)).

4: The resolution bandwidth of test receiver/spectrum analyzer is 1MHz and the video bandwidth is 10Hz (duty cycle > 98%) for Average detection (AV) at frequency above 1GHz.

Test Setup:

Test Setup 1: Emission test below 30MHz

The test site semi-anechoic chamber has met the requirement of NSA tolerance 4 dB according to the standards: ANSI C63.4. The test distance is 3m. The setup is according to ANSI C63.4.

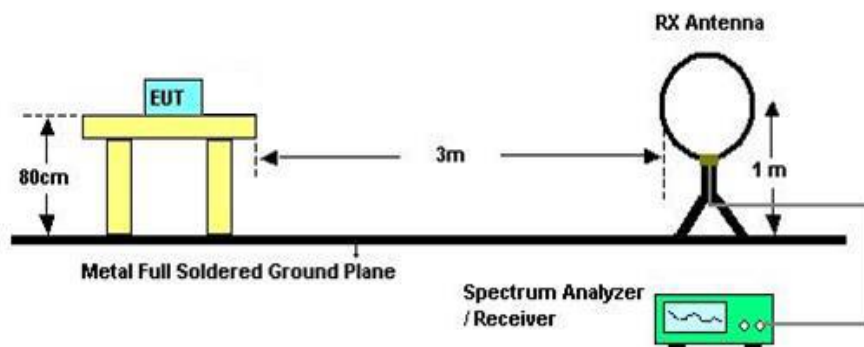

Test Setup 2: Emission test below 1GHz

The test site semi-anechoic chamber has met the requirement of NSA tolerance 4 dB according to the standards: ANSI C63.4. The test distance is 3m. The setup is according to ANSI C63.4.

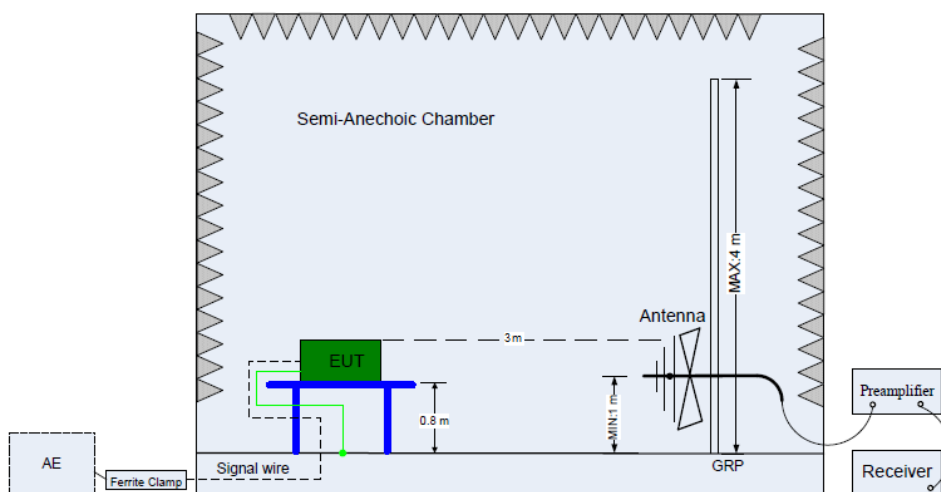

(Below 1 GHz)

Test Setup 3: Emission test above 1GHz

The test site semi-anechoic chamber has met the requirement of NSA tolerance 4 dB according to the standards: ANSI C63.4. The test distance is 3m. The setup is according to ANSI C63.4.

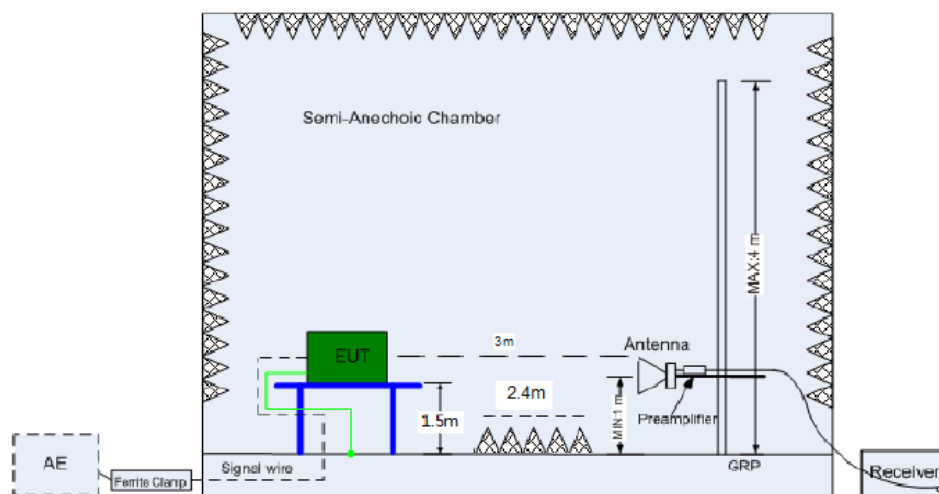

(Above 1 GHz)

Limit:

Radiated emissions which fall in the restricted bands, as defined in section 15.205, must comply with the radiated emission limits specified in section 15.209.

§ 15.209

Frequency MHz	Field Strength uV/m	Field Strength dBuV/m	Detector
30-88	100	40	QP
88-216	150	43.5	QP
216-960	200	46	QP
960-1000	500	54	QP
Above 1000	500	54	AV
Above 1000	5000	74	PK

§15.205 Restricted bands of operation

MHz	MHz	MHz	GHz
0.090-0.110	16.42-16.423	399.9-410	4.5-5.15
0.495-0.505	16.69475-16.69525	608-614	5.35-5.46
2.1735-2.1905	16.80425-16.80475	960-1240	7.25-7.75
4.125-4.128	25.5-25.67	1300-1427	8.025-8.5
4.17725-4.17775	37.5-38.25	1435-1626.5	9.0-9.2
4.20725-4.20775	73-74.6	1645.5-1646.5	9.3-9.5
6.215-6.218	74.8-75.2	1660-1710	10.6-12.7
6.26775-6.26825	108-121.94	1718.8-1722.2	13.25-13.4
6.31175-6.31225	123-138	2200-2300	14.47-14.5
8.291-8.294	149.9-150.05	2310-2390	15.35-16.2
8.362-8.366	156.52475-156.52525	2483.5-2500	17.7-21.4
8.37625-8.38675	156.7-156.9	2690-2900	22.01-23.12
8.41425-8.41475	162.0125-167.17	3260-3267	23.6-24.0
12.29-12.293	167.72-173.2	3332-3339	31.2-31.8
12.51975-12.52025	240-285	3345.8-3358	36.43-36.5
12.57675-12.57725	322-335.4	3600-4400	(?)
13.36-13.41			

Test Result: Pass

Conducted:

Test Method

According to KBD789033 D02

- a) RBW = 1 MHz.
- b) VBW = [3 × RBW].
- c) Detector = peak.
- d) Sweep time = auto.
- e) Trace mode = max hold.
- f) Allow sweeps to continue until the trace stabilizes. Note that if the transmission is not continuous, then the time required for the trace to stabilize will increase by a factor of approximately 1 / D, where D is the duty cycle. For example, at 50% duty cycle, the measurement time will increase by a factor of two, relative to measurement time for continuous transmission.

Test Setup:

The Wi-Fi component's antenna ports(s) of the EUT are connected to the measurement instrument per an appropriate attenuator. The EUT is controlled by PC/software to emit the specified signals for the purpose of measurements.

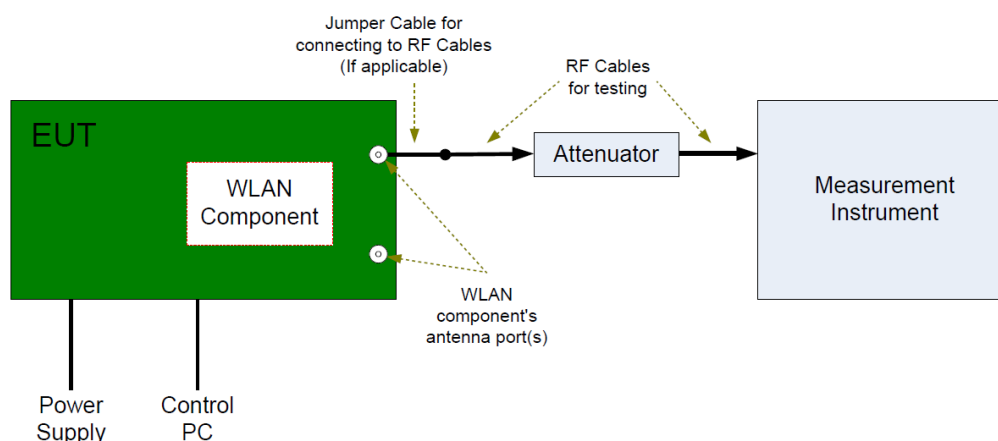

Limits:

For transmitters operating in the 5.15-5.25 GHz band: All emissions outside of the 5.15-5.35 GHz band shall not exceed an e.i.r.p. of -27 dBm/MHz.

For transmitters operating in the 5.25-5.35 GHz band: All emissions outside of the 5.15-5.35 GHz band shall not exceed an e.i.r.p. of -27 dBm/MHz.

For transmitters operating in the 5.47-5.725 GHz band: All emissions outside of the 5.47-5.725 GHz band shall not exceed an e.i.r.p. of -27 dBm/MHz.

For transmitters operating in the 5.725-5.85 GHz band: All emissions within the frequency range from the band edge to 10 MHz above or below the band edge shall not exceed an e.i.r.p. of -17 dBm/MHz; for frequencies 10 MHz or greater above or below the band edge, emissions shall not exceed an e.i.r.p. of -27 dBm/MHz.

Unwanted emissions below 1 GHz must comply with the general field strength limits set forth in §15.209.

The provisions of §15.205 apply to intentional radiators operating under this section.

Test Result: Pass

Remark: According to C63.10, if the peak (or quasi-peak) measured value complies with the average limit, it is unnecessary to perform an average measurement, so AV emission value did not show in below table if the peak value complies with average limit.
Pretest all modulation type, only show the worst data.

Radiated emission test data:
Below 1GHz

Frequency (MHz)	MaxPeak (dB μ V/m)	Limit (dB μ V/m)	Margin (dB)	Pol	Corr. (dB)
104.871875	18.54	43.50	24.96	H	16.1
424.971875	28.66	46.00	17.34	H	22.2
925.006875	36.72	46.00	9.28	H	31.2
68.860625	22.64	40.00	17.36	V	14.2
255.949375	27.62	46.00	18.38	V	17.9
944.770625	35.58	46.00	10.42	V	31.5

802.11a Modulation 5180MHz Test Result

Frequency (MHz)	MaxPeak (dB μ V/m)	Limit (dB μ V/m)	Margin (dB)	Pol	Corr. (dB)
1124.875000	31.13	74.00	42.87	V	-13.1
1772.875000	28.56	74.00	45.44	V	-8.5
10149.43750	41.40	74.00	32.60	V	9.6
11822.12500	44.30	74.00	29.70	V	12.2
13718.59375	44.95	74.00	29.05	V	14.3
22840.00000	42.07	74.00	31.93	V	-0.2
25900.06250	43.62	74.00	30.38	V	1.2
30517.31250	43.58	74.00	30.42	V	0.6
37808.25000	47.77	74.00	26.23	V	1.7
1652.500000	26.35	74.00	47.65	H	-9.4
3398.500000	32.83	74.00	41.17	H	-1.7
10754.78125	42.79	74.00	31.21	H	10.1
12462.18750	43.64	74.00	30.36	H	12.7
15008.68750	48.10	74.00	25.90	H	18.7
20719.75000	42.79	74.00	31.21	H	-2.3
25900.06250	45.03	74.00	28.97	H	1.2
31908.81250	43.12	74.00	30.88	H	0.5
39063.62500	47.80	74.00	26.20	H	2.2

802.11a Modulation 5240MHz Test Result

Frequency (MHz)	MaxPeak (dB μ V/m)	Limit (dB μ V/m)	Margin (dB)	Pol	Corr. (dB)
1035.437500	44.67	74.00	29.33	H	-13.9
2450.875000	29.21	74.00	44.79	H	-5.7
10650.96875	42.85	74.00	31.15	H	10.0
12340.84375	43.96	74.00	30.04	H	12.6
15012.46875	47.91	74.00	26.09	H	18.7
21324.75000	40.96	74.00	33.04	H	-1.5
25900.06250	44.38	74.00	29.62	H	1.2
31605.62500	43.69	74.00	30.31	H	0.4
39796.50000	47.16	74.00	26.84	H	3.2
1256.125000	28.95	74.00	45.05	V	-11.9
1699.937500	28.33	74.00	45.67	V	-8.9
11942.78125	44.42	74.00	29.58	V	12.0
15002.50000	48.65	74.00	25.35	V	18.7
16323.87500	48.70	74.00	25.30	V	19.9
25900.06250	44.07	74.00	29.93	V	1.2
31000.62500	43.66	74.00	30.34	V	0.6
39942.25000	47.92	74.00	26.08	V	3.4

802.11a Modulation 5260MHz Test Result

Frequency (MHz)	MaxPeak (dBμV/m)	Limit (dBμV /m)	Margin (dB)	Pol	Corr. (dB)
1535.500000	45.65	74.00	28.35	H	-10.8
1954.750000	39.22	74.00	34.78	H	-8.9
12388.62500	43.97	74.00	30.03	H	14.2
13307.12500	45.54	74.00	28.46	H	14.8
15813.06250	49.51	74.00	24.49	H	19.4
25711.00000	44.67	74.00	29.33	H	1.1
31202.75000	45.11	74.00	28.89	H	0.5
36186.43750	45.85	74.00	28.15	H	2.3
1535.500000	41.26	74.00	32.74	V	-10.8
1954.937500	37.15	74.00	36.85	V	-8.9
13112.21875	43.39	74.00	30.61	V	15.0
14530.87500	46.20	74.00	27.80	V	17.4
15752.21875	48.76	74.00	25.24	V	19.4
23025.62500	41.15	74.00	32.85	V	0.0
30810.18750	45.19	74.00	28.81	V	0.5
36177.50000	46.81	74.00	27.19	V	2.3

802.11a Modulation 5320MHz Test Result

Frequency (MHz)	MaxPeak (dBμV/m)	Limit (dBμV /m)	Margin (dB)	Pol	Corr. (dB)
1266.625000	28.68	74.00	45.32	H	-11.7
3425.125000	32.18	74.00	41.82	H	-0.6
7594.343750	40.72	74.00	33.28	H	9.9
9984.781250	41.28	74.00	32.72	H	9.5
12913.18750	44.21	74.00	29.79	H	15.1
21280.06250	46.85	74.00	27.15	H	-1.5
26599.93750	44.37	74.00	29.63	H	1.0
30403.18750	44.41	74.00	29.59	H	0.8
39735.31250	47.48	74.00	26.52	H	3.0
1259.312500	28.30	74.00	45.70	V	-11.7
3191.687500	31.50	74.00	42.50	V	-2.8
7644.187500	40.02	74.00	33.98	V	9.5
10655.78125	40.42	74.00	33.58	V	10.4
13124.59375	45.03	74.00	28.97	V	15.0
21280.06250	47.43	74.00	26.57	V	-1.5
26599.93750	44.26	74.00	29.74	V	1.0
33408.25000	43.59	74.00	30.41	V	-0.2
39876.93750	48.59	74.00	25.41	V	3.3

802.11a Modulation 5500MHz Test Result

Frequency (MHz)	MaxPeak (dBμV/m)	Limit (dBμV /m)	Margin (dB)	Pol	Corr. (dB)
1256.125000	29.13	74.00	44.87	H	-11.7
3586.000000	32.47	74.00	41.53	H	-0.2
9619.718750	41.70	74.00	32.30	H	9.6
11029.78125	38.50	74.00	35.50	H	9.9
13122.18750	43.63	74.00	30.37	H	15.0
21863.75000	41.37	74.00	32.63	H	-0.9
27673.81250	42.91	74.00	31.09	H	1.2
33545.75000	44.95	74.00	29.05	H	-0.1
1251.250000	28.20	74.00	45.80	V	-11.9
2802.625000	30.18	74.00	43.82	V	-4.2
8882.718750	39.99	74.00	34.01	V	8.5
10733.81250	40.54	74.00	33.46	V	10.3
13037.96875	44.62	74.00	29.38	V	15.1
21892.62500	41.74	74.00	32.26	V	-0.9
28476.12500	42.68	74.00	31.32	V	0.9
30634.18750	44.14	74.00	29.86	V	0.6

38844.31250	47.33	74.00	26.67	V	1.9
-------------	-------	-------	-------	---	-----

802.11a Modulation 5700MHz Test Result

Frequency (MHz)	MaxPeak (dBμV/m)	Limit (dBμV/m)	Margin (dB)	Pol	Corr. (dB)
1264.562500	29.14	74.00	44.86	H	-11.7
2742.062500	29.10	74.00	44.90	H	-4.2
9446.812500	39.62	74.00	34.38	H	9.7
10868.90625	39.52	74.00	34.48	H	9.9
14603.75000	45.66	74.00	28.34	H	17.7
22780.18750	42.15	74.00	31.85	H	-0.3
28377.81250	43.25	74.00	30.75	H	1.0
32645.12500	44.57	74.00	29.43	H	0.0
39925.75000	48.72	74.00	25.28	H	3.4
1755.062500	27.11	74.00	46.89	V	-9.7
3799.937500	36.06	74.00	37.94	V	-0.7
9514.531250	41.28	74.00	32.72	V	9.8
12407.53125	43.87	74.00	30.13	V	14.2
14497.87500	45.11	74.00	28.89	V	17.3
22173.81250	41.90	74.00	32.10	V	-0.6
28571.00000	42.75	74.00	31.25	V	1.0
33021.87500	44.39	74.00	29.61	V	0.0
39051.93750	47.25	74.00	26.75	V	2.2

802.11a Modulation 5720MHz Test Result

Frequency (MHz)	MaxPeak (dBμV/m)	Limit (dBμV/m)	Margin (dB)	Pol	Corr. (dB)
3300.062500	42.22	74.00	31.78	H	-1.7
3813.437500	38.66	74.00	35.34	H	-0.9
14112.87500	44.93	74.00	29.07	H	15.8
14998.03125	46.82	74.00	27.18	H	17.7
15866.68750	49.43	74.00	24.57	H	19.3
22259.06250	41.15	74.00	32.85	H	-0.5
25834.06250	41.93	74.00	32.07	H	1.2
31164.25000	43.22	74.00	30.78	H	0.6
3300.062500	39.02	74.00	34.98	V	-1.7
3813.437500	41.51	74.00	32.49	V	-0.9
12490.03125	43.65	74.00	30.35	V	14.4
14449.40625	45.39	74.00	28.61	V	16.9
15852.93750	47.95	74.00	26.05	V	19.3
22158.00000	41.71	74.00	32.29	V	-0.6
24893.56250	41.99	74.00	32.01	V	0.7
30623.87500	44.56	74.00	29.44	V	0.6

802.11a Modulation 5745MHz Test Result

Frequency (MHz)	MaxPeak (dBμV/m)	Limit (dBμV/m)	Margin (dB)	Pol	Corr. (dB)
1264.375000	29.34	74.00	44.66	H	-11.7
2511.250000	28.71	74.00	45.29	H	-4.5
9442.000000	40.85	74.00	33.15	H	9.7
10618.65625	40.85	74.00	33.15	H	10.3
13004.62500	45.03	74.00	28.97	H	15.2
21851.37500	41.15	74.00	32.85	H	-0.9
27174.00000	42.72	74.00	31.28	H	1.1
29921.25000	43.82	74.00	30.18	H	1.3
39489.87500	47.39	74.00	26.61	H	2.6
1259.500000	27.57	74.00	46.43	V	-11.7
2541.250000	30.17	74.00	43.83	V	-4.3
3829.937500	39.11	74.00	34.89	V	-1.2

9230.250000	39.12	74.00	34.88	V	9.5
10814.59375	40.97	74.00	33.03	V	10.0
13009.43750	45.52	74.00	28.48	V	15.2
22041.81250	41.75	74.00	32.25	V	-0.8
26963.62500	42.70	74.00	31.30	V	1.1
29968.68750	44.30	74.00	29.70	V	1.3
39575.12500	47.47	74.00	26.53	V	2.7

802.11a Modulation 5825MHz Test Result

Frequency (MHz)	MaxPeak (dB μ V/m)	Limit (dB μ V/m)	Margin (dB)	Pol	Corr. (dB)
1124.875000	33.11	74.00	40.89	H	-12.5
3883.375000	35.58	74.00	38.42	H	-1.1
8776.500000	38.98	74.00	35.02	H	8.8
10682.93750	40.30	74.00	33.70	H	10.4
12435.71875	43.35	74.00	30.65	H	14.3
23299.93750	42.45	74.00	31.55	H	0.0
26107.00000	42.25	74.00	31.75	H	1.1
32653.37500	43.43	74.00	30.57	H	0.0
39523.56250	47.90	74.00	26.10	H	2.6
1255.937500	27.79	74.00	46.21	V	-11.8
2189.312500	27.32	74.00	46.68	V	-7.2
3883.375000	38.34	74.00	35.66	V	-1.1
10773.00000	41.75	74.00	32.25	V	10.2
13038.65625	44.17	74.00	29.83	V	15.1
14549.09375	46.11	74.00	27.89	V	17.5
20237.12500	40.52	74.00	33.48	V	-3.0
22796.00000	42.28	74.00	31.72	V	-0.3
29943.93750	43.95	74.00	30.05	V	1.3
39054.68750	47.86	74.00	26.14	V	2.2

Remark:

- (1) Above 1GHz Corrector factor= Antenna Factor +Cable Loss - Amp. Factor.
- (2) Below 1GHz Corrector factor= Antenna Factor +Cable Loss.
- (3) "*" means the emission(s) appear within the restrict bands shall follow the requirement of section 15.205.
- (4) We test all modes and only the worst case for each bandwidth recorded in the report.
- (5) Testing is carried out with frequency rang 30MHz to 40GHz, which data of measurement within this frequency range shown "---" in the table above means the reading of emissions are attenuated more than 20dB below the permissible limits or the field strength is too small to be measured.
- (6) The Low frequency, which start from 9KHz to 30MHz, was pre-scanned and the result which was 20dB lower than the limit line per 15.31(o) was not reported.

8.6. Band Edge

Test Method

According to KBD789033 D02 (Integration Method)

- a) Set RBW = 100 kHz
- b) Set VBW $\geq 3 \times$ RBW
- c) Perform a band-power integration across the 1 MHz bandwidth in which the band-edge emission level is to be measured.

Limits:

For transmitters operating in the 5.15-5.25 GHz band: All emissions outside of the 5.15-5.35 GHz band shall not exceed an e.i.r.p. of -27 dBm/MHz.

For transmitters operating in the 5.25-5.35 GHz band: All emissions outside of the 5.15-5.35 GHz band shall not exceed an e.i.r.p. of -27 dBm/MHz.

For transmitters operating in the 5.47-5.725 GHz band: All emissions outside of the 5.47-5.725 GHz band shall not exceed an e.i.r.p. of -27 dBm/MHz.

For transmitters operating in the 5.725-5.85 GHz band: All emissions within the frequency range from the band edge to 10 MHz above or below the band edge shall not exceed an e.i.r.p. of -17 dBm/MHz; for frequencies 10 MHz or greater above or below the band edge, emissions shall not exceed an e.i.r.p. of -27 dBm/MHz.

Test Setup:

The Wi-Fi component's antenna ports(s) of the EUT are connected to the measurement instrument per an appropriate attenuator. The EUT is controlled by PC/software to emit the specified signals for the purpose of measurements.

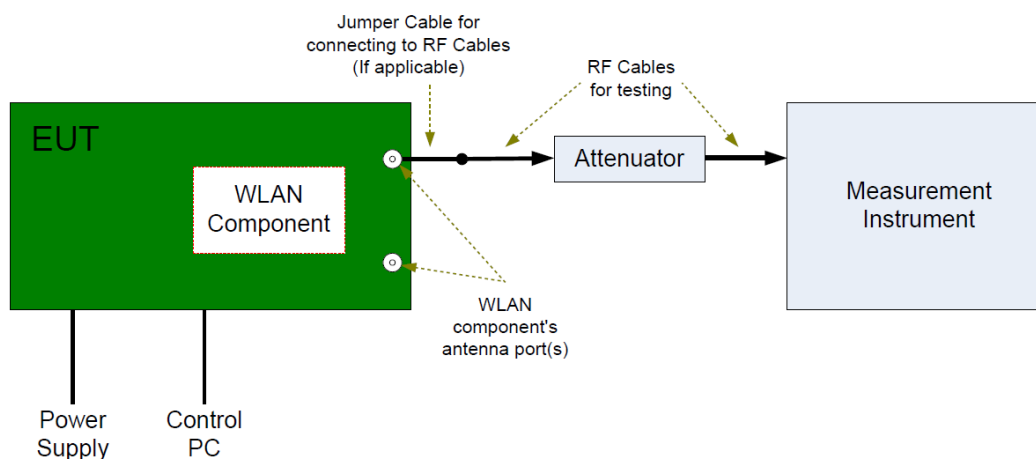

Test Result: Pass

8.7. Frequencies Stability

Test Method

- a) Connect the UUT to the spectrum analyzer
- b) Set Centre Frequency of the channel under test.
- c) Set Detector PEAK
- d) Set RBW: 10KHz, VBW: 3RBW
- e) Set Span: Encompass the entire emissions bandwidth (EBW) of the signal.
- f) Allow the trace to stabilize, find the peak value of the power envelope and record the frequency, then calculated the frequency drift.

The test extreme voltage is to change the primary supply voltage from 85 to 115 percent of the nominal value.

User manual temperature is -10°C to 35°C

Limit: 20ppm

Test Setup:

The Wi-Fi component's antenna ports(s) of the EUT are connected to the measurement instrument per an appropriate attenuator. The EUT is controlled by PC/software to emit the specified signals for the purpose of measurements.

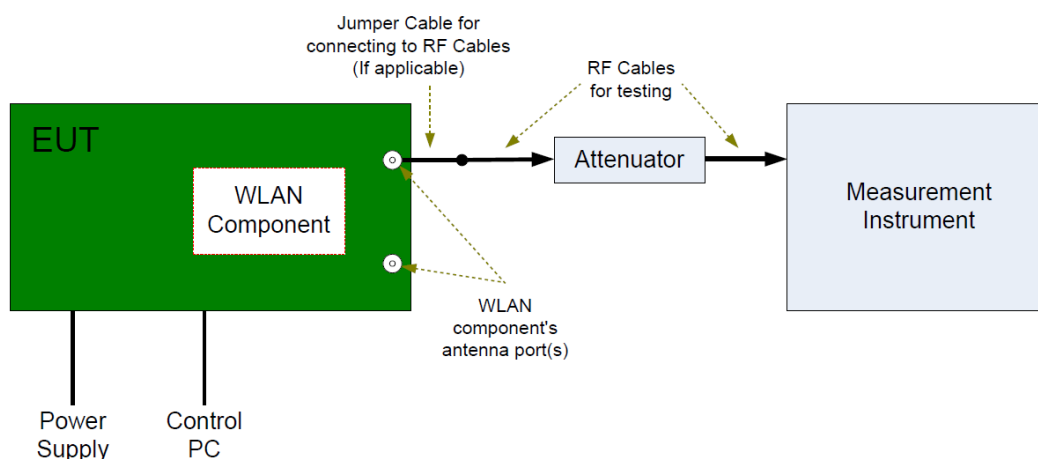

Test Result: Pass

8.8. Dynamic Frequency Selection (DFS)

General Test Condition

Parameters of EUT	
Frequency	5250 – 5350 MHz & 5470 – 5725 MHz
Operational Mode	Slave
Modulation:	OFDM
Channel Bandwidth:	20 MHz , 40 MHz

Note: This device was functioned as a Slave device during the DFS

Test requirement

The manufacturer shall whether the EUT is capable of operating as a master and a client. If the EUT is capable of operating in more than one operating mode then each operating mode shall be tested separately.

DFS Applicability

Requirement	Operational Mode		
	Master	Client Without Radar Detection	Client With Radar Detection
Non-Occupancy Period	Yes	Not required	Yes
DFS Detection Threshold	Yes	Not required	Yes
Channel Availability Check Time	Yes	Not required	Not required
Uniform Spreading	Yes	Not required	Not required
U-NII Detection Bandwidth	Yes	Not required	Yes

DFS Applicability During Normal Operation

Requirement	Operational Mode		
	Master	Client Without Radar Detection	Radar Detection
Non-Occupancy Period	Yes	Not required	Yes
DFS Detection Threshold	Yes	Not required	Yes
Channel Availability Check Time	Yes	Yes	Not required
Uniform Spreading	Yes	Yes	Not required
U-NII Detection Bandwidth	Yes	Not required	Yes

Test Limited

According to KDB 905462 D02 Table 4 DFS Response Requirement Values

Parameter	Value
<i>Non-occupancy period</i>	Minimum 30 minutes
<i>Channel Availability Check Time</i>	60 seconds
<i>Channel Move Time</i>	10 seconds See Note 1.
<i>Channel Closing Transmission Time</i>	200 milliseconds + an aggregate of 60 milliseconds over remaining 10 second period. See Notes 1 and 2.
<i>U-NII Detection Bandwidth</i>	Minimum 100% of the U-NII 99% transmission power bandwidth. See Note 3.
<p>Note 1: <i>Channel Move Time</i> and the <i>Channel Closing Transmission Time</i> should be performed with Radar Type 0. The measurement timing begins at the end of the Radar Type 0 burst.</p> <p>Note 2: The <i>Channel Closing Transmission Time</i> is comprised of 200 milliseconds starting at the beginning of the <i>Channel Move Time</i> plus any additional intermittent control signals required to facilitate a <i>Channel</i> move (an aggregate of 60 milliseconds) during the remainder of the 10 second period. The aggregate duration of control signals will not count quiet periods in between transmissions.</p> <p>Note 3: During the <i>U-NII Detection Bandwidth</i> detection test, radar type 0 should be used. For each frequency step the minimum percentage of detection is 90 percent. Measurements are performed with no data traffic.</p>	

4、 Calibration of Radar Waveform

- (1) A 50ohm load is connected in place of the spectrum analyzer, and the spectrum analyzer is connected to place of the master.
- (2) The interference Radar Detection Threshold Level is $-62\text{dBm}+3.7\text{dB}+1.5\text{dB}=-55.8\text{dBm}$ that had been taken into account the output power range and antenna gain.
- (3) The following equipment setup was used to calibrate the conducted radar waveform. A vector signal generator was utilized to establish the test signal level for radar type 0. During this process there were no transmissions by either the master or client device. The spectrum analyzer was switched to the zero spans (time domain) at the frequency of the radar waveform generator. Peak detection was used. The spectrum analyzer resolution bandwidth (RBW) and video bandwidth (VBW) were set to 3MHz. The spectrum analyzer had offset -1.5dB to compensate RF cable loss 1.5dB.
- (4) The vector signal generator amplitude was set so that the power level measured at the spectrum analyzer was $-62\text{dBm}+3.7\text{dB}+1.5\text{dB}=-55.8\text{dBm}$. Capture the spectrum analyzer plots on short pulse radar waveform.

Conducted Calibration Setup:

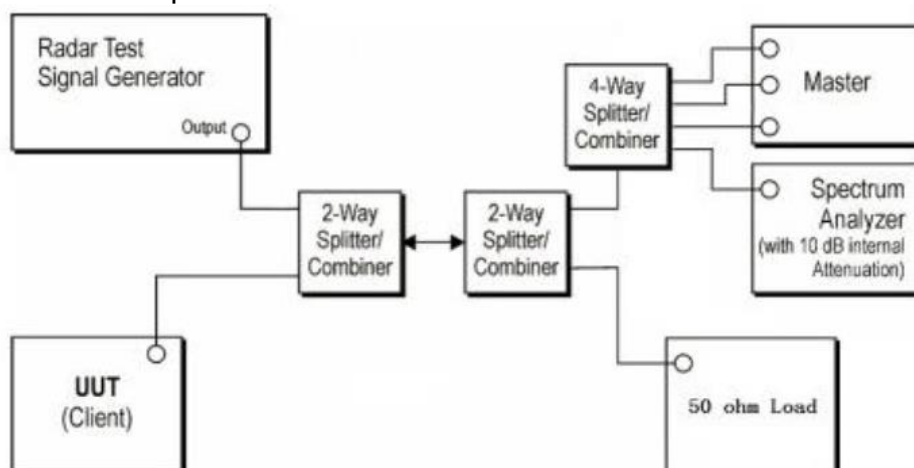

Radar Waveform Calibration result:

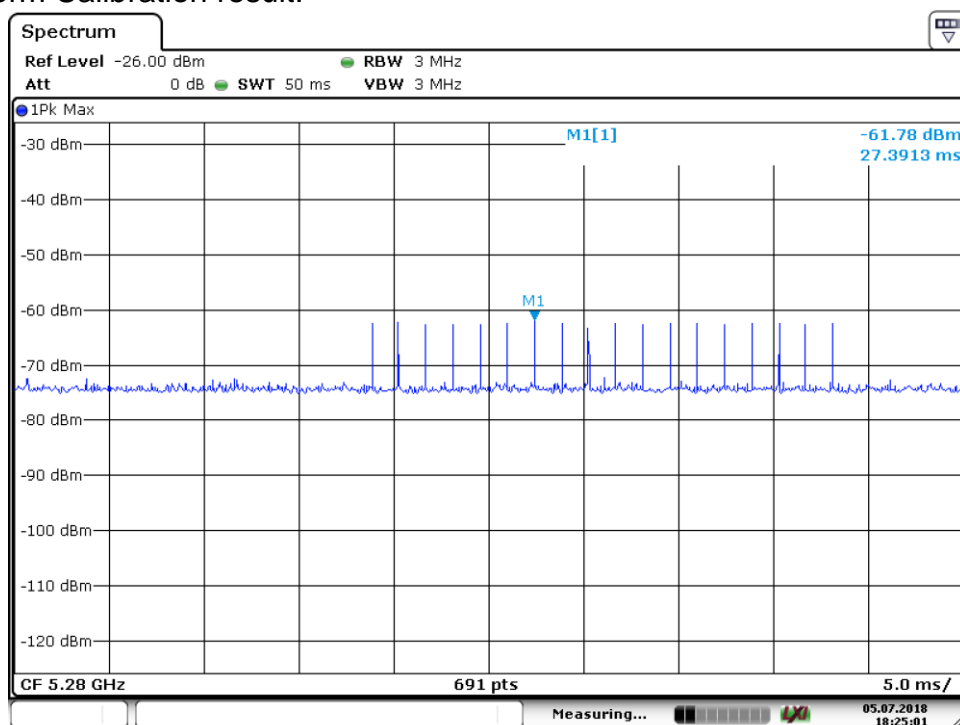

Channel Closing Transmission Time, Channel Move Time and Non-Occupancy Period.

Block Diagram of test setup test procedure.

- (1) The Radar Pulse generator is setup to provide a pulse at frequency that the master and client are operating, A type 0 radar pulse with a 1us pulse width and a 1428us PRI is used for the testing.
- (2) The vector signal generator is adjusted to provide the radar burst (18 pulses) at the level of approximately -55.8dBm at the antenna of the master device.
- (3) A trigger is provided from the pulse generator to the DFS monitoring system in order to capture the traffic and the occurrence of the radar pulse.
- (4) EUT will associate with the master at channel. The file "iperf.exe" specified by the FCC is streamed from the PC 2 through the master and the client device to the PC 1 and played in full motion video using test software in order to properly load the network for the entire period of the test.
- (5) When radar burst with a Level equal to the DFS Detection Threshold +1dB is generated on the operating channel of the U-NII device. At time T₀ the radar waveform generator sends a burst of pulse of the radar waveform at Detection threshold +1dB.
- (6) Observer the transmissions of the EUT at the end of the radar Burst on the Operating channel. Measure and record the transmissions from the UUT during The observation time (channel move time). One 15 seconds plot is reported for the short pulse radar type 0. The plot for the short pulse radar burst. The channel move time will be calculated based on the zoom in 600ms plot of the short pulse radar type.
- (7) Measurement of the aggregate duration of the channel closed transmission time method. With the spectrum analyzer set to zero span tuned to the center frequency of the EUT operating channel at the radar simulated frequency, peak detection, and max hold, the dwell time per bin is given by: $Dwell(3.0) = S(12000ms) / B(4000)$; where dwell time per spectrum analyzer sampling bin, S is sweep time and B is the number of spectrum analyzer sampling bins. An upper bound of the aggregate duration of the intermittent control signals of channel closing transmission time is calculated by: $C(ms) = N \times Dwell(0.3ms)$; where C is the closing time, N is the number of spectrum analyzer sampling bins (intermittent control signals) showing a U-NII transmission and dwell is the dwell time per bin.
- (8) Measurement the EUT for more than 30 minutes following the channel move time to verify that no transmission or beacons occur on this channel.

Test Setup:

Setup for client with injection at the master.

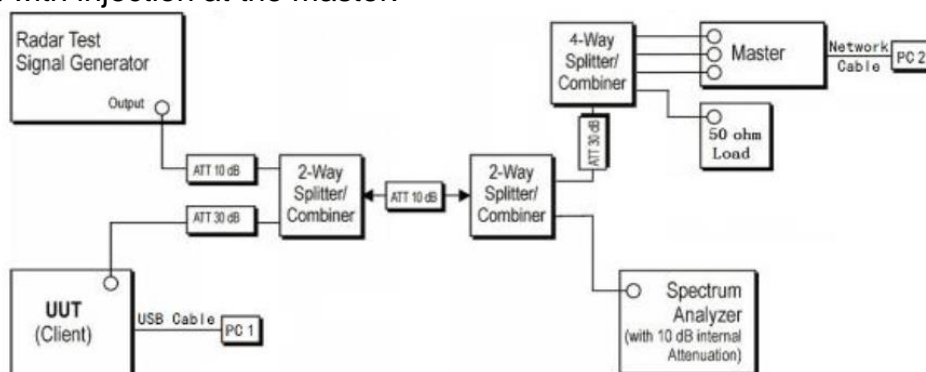

Test Result: Pass

8. Test Equipment List

Radiated Emission Test

DESCRIPTION	MANUFACTURER	MODEL NO.	SERIAL NO.	CAL. DUE DATE
EMI Test Receiver	Rohde & Schwarz	ESR 26	101269	2019-7-6
Trilog Super Broadband Test Antenna	Schwarzbeck	VULB 9163	707	2019-7-13
Horn Antenna	Rohde & Schwarz	HF907	102294	2019-7-13
Pre-amplifier	Rohde & Schwarz	SCU 18	102230	2019-7-6
Signal Generator	Rohde & Schwarz	SMY01	839369/005	2019-7-6
Attenuator	Agilent	8491A	MY39264334	2019-7-6
3m Semi-anechoic chamber	TDK	9X6X6	----	2020-7-7
Test software	Rohde & Schwarz	EMC32	Version 9.15.00	N/A

Conducted Emission Test

DESCRIPTION	MANUFACTURER	MODEL NO.	SERIAL NO.	CAL. DUE DATE
EMI Test Receiver	Rohde & Schwarz	ESR 3	101782	2019-7-6
LISN	Rohde & Schwarz	ENV4200	100249	2019-7-6
LISN	Rohde & Schwarz	ENV432	101318	2019-7-6
LISN	Rohde & Schwarz	ENV216	100326	2019-7-6
ISN	Rohde & Schwarz	ENY81	100177	2019-7-6
ISN	Rohde & Schwarz	ENY81-CA6	101664	2019-7-6
High Voltage Probe	Rohde & Schwarz	TK9420(VT9420)	9420-584	2019-6-30
RF Current Probe	Rohde & Schwarz	EZ-17	100816	2019-6-30
Attenuator	Shanghai Huaxiang	TS2-26-3	080928189	2019-7-6
Test software	Rohde & Schwarz	EMC32	Version 9.15.00	N/A

TS8997 Test System

DESCRIPTION	MANUFACTURER	MODEL NO.	SERIAL NO.	CAL. DUE DATE
Signal Generator	Rohde & Schwarz	SMB100A	108272	2019-7-6
Vector Signal Generator	Rohde & Schwarz	SMBV100A	262825	2019-7-6
Communication Synthetic Test Instrument	Rohde & Schwarz	CMW 270	101251	2019-5-31
Signal Analyzer	Rohde & Schwarz	FSV40	101030	2019-7-6
Vector Signal Generator	Rohde & Schwarz	SMU 200A	105324	2019-7-6
RF Switch Module	Rohde & Schwarz	OSP120/OSP-B157	101226/100851	2019-7-6
Power Splitter	Weinschel	1580	SC319	2019-7-5
10dB Attenuator	Weinschel	4M-10	43152	2019-7-6
10dB Attenuator	R&S	DNF	DNF-001	2019-7-6
10dB Attenuator	R&S	DNF	DNF-002	2019-7-6
10dB Attenuator	R&S	DNF	DNF-003	2019-7-6
10dB Attenuator	R&S	DNF	DNF-004	2019-7-6
Test software	Rohde & Schwarz	EMC32	Version 10.38.00	N/A
Test software	Tonscend	System for BT/WIFI	Version 2.6	N/A

9. System Measurement Uncertainty

System Measurement Uncertainty

For a 95% confidence level, the measurement expanded uncertainties for defined systems, in accordance with the recommendations of ISO 17025 were:

System Measurement Uncertainty	
Test Items	Extended Uncertainty
Uncertainty for Radiated Emission in 3m chamber 30MHz-1000MHz	Horizontal: 4.91dB; Vertical: 4.89dB;
Uncertainty for Radiated Emission in 3m chamber 1000MHz-18000MHz	Horizontal: 4.80dB; Vertical: 4.79dB;
Uncertainty for Radiated Spurious Emission 18000MHz-40000MHz	Horizontal: 5.05dB; Vertical: 5.04dB;
Uncertainty for Conducted Emission 150kHz-30MHz	3.21dB
Uncertainty for Conducted RF test with TS 8997	RF Power Conducted: 1.16dB Frequency test involved: 0.6×10^{-7} or 1%
Uncertainty Evaluation for Power Spectral Density Conducted measurement	1.17dB
Uncertainty Evaluation for Spurious emissions Conducted measurement	1.43dB