



FCC TEST REPORT

FCC ID: 2AEBCXPOS-I100

On Behalf of

ZHUHAI HONOR TECHNOLOGY CO.LTD

Smart handheld printer

Model No.: XPOS-I100, XPOS-I100A, XPOS-I100B, XPOS-I100C, XPOS-I100D, XPOS-I100E, XPOS-I100F, XPOS-I100S, XPOS-I100P, XPOS-I100X, XPOS-I100C1, XPOS-I100C2, XPOS-I100C3, XPOS-I100S1, XPOS-I100S2, XPOS-I100S3, POS-I100, POS-I100A, POS-I100B, POS-I100C, POS-I100D, POS-I100E, POS-I100F, POS-I100S, POS-I100P, POS-I100X, POS-I100C1, POS-I100C2, POS-I100C3, POS-I100S1, POS-I100S2, POS-I100S3

Prepared for : ZHUHAI HONOR TECHNOLOGY CO.LTD
Address : A 2nd Floor,Building 3,No. 639,Huayu Road,Xiangzhou District,Zhuhai,China

Prepared By : Shenzhen Alpha Product Testing Co., Ltd.
Address : Building i, No.2, Lixin Road, Fuyong Street, Bao'an District, 518103, Shenzhen, Guangdong, China

Report Number : A1907043-C01-R12
Date of Receipt : July 16, 2019
Date of Test : July 16, 2019-September 04, 2019
Date of Report : September 06, 2019
Version Number : V0

TABLE OF CONTENTS

Description	Page
1. Summary of Standards And Results	6
1.1. Description of Standards and Results	6
2. General Information.....	7
2.1. Description of Device (EUT).....	7
2.2. Accessories of Device (EUT)	8
2.3. Tested Supporting System Details	8
2.4. Block Diagram of connection between EUT and simulators	8
2.5. Test Mode Description.....	8
2.6. Test Conditions	9
2.7. Test Facility	9
2.8. Measurement Uncertainty.....	9
2.9. Test Equipment List.....	10
3. Maximum Peak Output power	11
3.1. Limit	11
3.2. Test Procedure	11
3.3. Test Setup.....	11
3.4. Test Result	11
4. Bandwidth.....	12
4.1. Limit	12
4.2. Test Procedure	12
4.3. Test Result	12
5. Carrier Frequency Separation.....	16
5.1. Limit	16
5.2. Test Procedure	16
5.3. Test Result	16
6. Number Of Hopping Channel.....	22
6.1. Limit	22
6.2. Test Procedure	22
6.3. Test Result	22
7. Dwell Time.....	28
7.1. Test limit	28
7.2. Test Procedure	28
7.3. Test Result	28
8. Radiated emissions.....	34
8.1. Limit	34
8.2. Block Diagram of Test setup	35
8.3. Test Procedure	36
8.4. Test Result	36
9. Band Edge Compliance	41

9.1. Block Diagram of Test Setup.....	41
9.2. Limit	41
9.3. Test Procedure	41
9.4. Test Result	41
10. Power Line Conducted Emissions	60
10.1. Block Diagram of Test Setup.....	60
10.2. Limit	60
10.3. Test Procedure	60
10.4. Test Result	60
11. Antenna Requirements	62
11.1. Limit	62
11.2. Result	62
12. Test setup photo	63
12.1. Photos of Radiated emission.....	63
12.2. Photos of Conducted Emission test	64
13. Photos of EUT	65

TEST REPORT DECLARATION

Applicant : ZHUHAI HONOR TECHNOLOGY CO.LTD
 Address : A 2nd Floor,Building 3,No. 639,Huayu Road,Xiangzhou District,Zhuhai,China
 Manufacturer : ZHUHAI HONOR TECHNOLOGY CO.LTD
 Address : A 2nd Floor,Building 3,No. 639,Huayu Road,Xiangzhou District,Zhuhai,China
 EUT Description : Smart handheld printer

XPOS-I100, XPOS-I100A, XPOS-I100B, XPOS-I100C,
 XPOS-I100D, XPOS-I100E, XPOS-I100F, XPOS-I100S,
 XPOS-I100P, XPOS-I100X, XPOS-I100C1,
 XPOS-I100C2, XPOS-I100C3, XPOS-I100S1,
 (A) Model No. : XPOS-I100S2, XPOS-I100S3, POS-I100, POS-I100A,
 POS-I100B, POS-I100C, POS-I100D, POS-I100E,
 POS-I100F, POS-I100S, POS-I100P, POS-I100X,
 POS-I100C1, POS-I100C2, POS-I100C3, POS-I100S1,
 POS-I100S2, POS-I100S3
 (B) Trademark : N/A

Measurement Standard Used:

FCC Rules and Regulations Part 15 Subpart C Section 15.247
ANSI C63.10:2013

The device described above is tested by Shenzhen Alpha Product Testing Co., Ltd. to determine the maximum emission levels emanating from the device. The maximum emission levels are compared to the FCC Part 15 Subpart C limits both conducted and radiated emissions. The test results are contained in this test report and Shenzhen Alpha Product Testing Co., Ltd. is assumed of full responsibility for the accuracy and completeness of these tests.

After the test, our opinion is that EUT compliance with the requirement of the above standards.

This report applies to above tested sample only. This report shall not be reproduced in parts without written approval of Shenzhen Alpha Product Testing Co., Ltd.

Tested by (name + signature).....: Ella Liang 
 Project Engineer

Approved by (name + signature).....: Simple Guan 
 Project Manager

Date of issue.....: September 06, 2019

Revision History

Revision	Issue Date	Revisions	Revised By
V0	September 06, 2019	Initial released Issue	Simple Guan

1. SUMMARY OF STANDARDS AND RESULTS

1.1. Description of Standards and Results

The EUT have been tested according to the applicable standards as referenced below:

Test Item	Standards Paragraph	Result
Maximum Peak Output Power	FCC Part 15: 15.247(b)(1) ANSI C63.10 :2013	P
Bandwidth	FCC Part 15: 15.215 ANSI C63.10 :2013	P
Carrier Frequency Separation	FCC Part 15: 15.247(a)(1) ANSI C63.10 :2013	P
Number Of Hopping Channel	FCC Part 15: 15.247(a)(1)(iii) ANSI C63.10 :2013	P
Dwell Time	FCC Part 15: 15.247(a)(1)(iii) ANSI C63.10 :2013	P
Radiated Emission	FCC Part 15: 15.209 FCC Part 15: 15.247(d) ANSI C63.10 :2013	P
Band Edge Compliance	FCC Part 15: 15.247(d) ANSI C63.10 :2013	P
Power Line Conducted Emissions	FCC Part 15: 15.207 ANSI C63.10 :2013	P
Antenna requirement	FCC Part 15: 15.203	P
Note:	<ol style="list-style-type: none"> 1. P is an abbreviation for Pass. 2. F is an abbreviation for Fail. 3. N/A is an abbreviation for Not Applicable. 	

2. GENERAL INFORMATION

2.1. Description of Device (EUT)

Description	: Smart handheld printer
Trademark	: N/A
Model Number	: XPOS-I100, XPOS-I100A, XPOS-I100B, XPOS-I100C, XPOS-I100D, XPOS-I100E, XPOS-I100F, XPOS-I100S, XPOS-I100P, XPOS-I100X, XPOS-I100C1, XPOS-I100C2, XPOS-I100C3, XPOS-I100S1, XPOS-I100S2, XPOS-I100S3, POS-I100, POS-I100A, POS-I100B, POS-I100C, POS-I100D, POS-I100E, POS-I100F, POS-I100S, POS-I100P, POS-I100X, POS-I100C1, POS-I100C2, POS-I100C3, POS-I100S1, POS-I100S2, POS-I100S3
DIFF.	: All model's the function, software and electric circuit are the same, except the model number difference. This report performs the model XPOS-I100.
Test Voltage	: DC 3.8V from battery or Input DC 5V/2A

BT

Radio Technology	: Bluetooth V4.1 EDR
Operation frequency	: 2402-2480MHz
Channel No.	: 79 Channels
Modulation type	: GFSK, $\pi/4$ DQPSK, 8 - DPSK
Antenna Type	: PIFA antenna, Maximum Gain is 1.56dBi
Software version	: V1.0
Hardware version	: L5F1GB-V2

2.2. Accessories of Device (EUT)

Accessories 1	: Switching power adapter
Manufacturer	: Shenzhen Fangxin Technology Co., Ltd.
Model	: FX2U-050200U
Input	: AC 100-240V, 50/60Hz, 0.4A max
Output	: DC 5V/2A
Accessories 2	: USB Cable
Manufacturer	: Dongguan j Julian Electronics Co., Ltd.
Model	: /
Ratings	: 1m
Accessories 3	: Charging base
Manufacturer	: ZHUHAI HONOR TECHNOLOGY CO.LTD
Model	: XPOS-I100 Charging base
Input	: DC 5V/2A

2.3. Tested Supporting System Details

No.	Description	Manufacturer	Model	Serial Number	Certification or DOC
1.	Notebook	ACER	ZQT	N/A	DOC

2.4. Block Diagram of connection between EUT and simulators

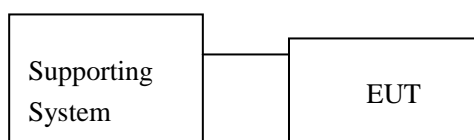

2.5. Test Mode Description

Tested mode, channel, and data rate information		
Mode	Channel	Frequency (MHz)
GFSK	Low :CH1	2402
	Middle: CH40	2441
	High: CH79	2480
π /4 DQPSK	Low :CH1	2402
	Middle: CH40	2441
	High: CH79	2480
8- DPSK	Low :CH1	2402
	Middle: CH40	2441
	High: CH79	2480

2.6. Test Conditions

Items	Required	Actual
Temperature range:	15-35°C	24°C
Humidity range:	25-75%	56%
Pressure range:	86-106kPa	98kPa

2.7. Test Facility

Shenzhen Alpha Product Testing Co., Ltd

Building i, No.2, Lixin Road, Fuyong Street, Bao'an District, 518103,
Shenzhen, Guangdong, China

June 21, 2018 File on Federal Communication Commission

Registration Number: 293961

July 15, 2019 Certificated by IC

Registration Number: CN0085

2.8. Measurement Uncertainty

(95% confidence levels, k=2)

Item	Uncertainty
Uncertainty for Power point Conducted Emissions Test	2.74dB
Uncertainty for Radiation Emission test in 3m chamber (below 30MHz)	2.13 dB(Polarize: V)
	2.57dB(Polarize: H)
Uncertainty for Radiation Emission test in 3m chamber (30MHz to 1GHz)	3.77dB(Polarize: V)
	3.80dB(Polarize: H)
Uncertainty for Radiation Emission test in 3m chamber (1GHz to 25GHz)	4.16dB(Polarize: H)
	4.13dB(Polarize: V)
Uncertainty for radio frequency	5.4×10^{-8}
Uncertainty for conducted RF Power	0.37dB
Uncertainty for temperature	0.2°C
Uncertainty for humidity	1%
Uncertainty for DC and low frequency voltages	0.06%

2.9. Test Equipment List

Equipment	Manufacture	Model No.	Serial No.	Last cal.	Cal Interval
9*6*6 anechoic chamber	CHENYU	9*6*6	N/A	2018.09.21	1 Year
Spectrum analyzer	ROHDE&SCHWARZ	FSU	1166.1660.26	2018.09.21	1 Year
Spectrum analyzer	Agilent	N9020A	MY499100060	2018.09.11	1 Year
Receiver	ROHDE&SCHWARZ	ESR	1316.3003K03-102082-Wa	2018.09.21	1 Year
Receiver	R&S	ESCI	101165	2018.09.21	1 Year
Bilog Antenna	Schwarzbeck	VULB 9168	VULB9168-438	2018.04.13	2 Year
Horn Antenna	SCHWARZBECK	BBHA 9120 D	BBHA 9120 D(1201)	2018.04.13	2 Year
Active Loop Antenna	SCHWARZBECK	FMZB 1519B	00059	2018.09.26	2 Year
Cable	Resenberger	N/A	No.1	2018.09.21	1 Year
Cable	Resenberger	N/A	No.2	2018.09.21	1 Year
Cable	Resenberger	N/A	No.3	2018.09.21	1 Year
Pre-amplifier	HP	HP8347A	2834A00455	2018.09.21	1 Year
Pre-amplifier	Agilent	8449B	3008A02664	2018.09.21	1 Year
L.I.S.N.#1	Schwarzbeck	NSLK8126	8126466	2018.09.21	1 Year
L.I.S.N.#2	ROHDE&SCHWARZ	ENV216	101043	2018.09.21	1 Year
20db Attenuator	ICPROBING	IATS1	82347	2018.09.21	1 Year
Horn Antenna	A-INFOMW	LB-180100-KF	J211020657	2018.09.21	2 Year
Preamplifier	SKET	LNPA_1840-50	SK2018101801	2018.09.21	1 Year
Power Meter	Agilent	E9300A	MY41496625	2018.09.21	1 Year
Temp. & Humid. Chamber	Weihuang	WHTH-1000-40-880	100631	2018.9.11	1 Year
Switching Mode Power Supply	JUNKE	JK12010S	20140927-6	2018.09.11	1 Year

3. MAXIMUM PEAK OUTPUT POWER

3.1.Limit

Please refer section 15.247.

For frequency hopping systems operating in the 2400-2483.5 MHz band employing at least 75 non-overlapping hopping channels, and all frequency hopping systems in the 5725-5850 MHz band: 1 watt. For all other frequency hopping systems in the 2400-2483.5 MHz band: 0.125 watts, the e.i.r.p shall not exceed 4W

3.2.Test Procedure

The transmitter output is connected to the RF Power Meter. The RF Power Meter is set to the average power detection.

3.3.Test Setup

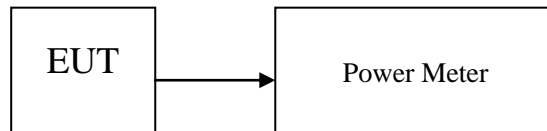

3.4.Test Result

Mode	Freq (MHz)	Average Output Power (dBm)	Limit (dBm)	Result
GFSK	2402	5.23	21	Pass
	2441	5.19	21	Pass
	2480	5.29	21	Pass
$\pi/4$ DQPSK	2402	3.20	21	Pass
	2441	3.19	21	Pass
	2480	3.24	21	Pass
8-DPSK	2402	3.11	21	Pass
	2441	3.20	21	Pass
	2480	3.18	21	Pass
Conclusion: PASS				

4. BANDWIDTH

4.1.Limit

Intentional radiators operating under the alternative provisions to the general emission limits, as contained in §§ 15.217 through 15.257 and in Subpart E of this part, must be designed to ensure that the 20 dB bandwidth of the emission, or whatever bandwidth may otherwise be specified in the specific rule section under which the equipment operates, is contained within the frequency band designated in the rule section under which the equipment is operated.

4.2.Test Procedure

The RF output of EUT was connected to the spectrum analyzer by RF cable and attenuator. The bandwidth of the fundamental frequency was measured by spectrum analyzer with 30kHz RBW and 100kHz VBW. The 20dB bandwidth is defined as the total spectrum the power of which is higher than peak power minus 20dB.

4.3.Test Result

Condition	Mode	Frequency (MHz)	99% OBW (MHz)	-20 dB Bandwidth (MHz)	Limit -20 dB Bandwidth (MHz)	Verdict
NVNT	1-DH1	2402	0.8607	0.7022	0	Pass
NVNT	1-DH1	2441	0.8367	0.7646	0	Pass
NVNT	1-DH1	2480	0.8447	0.707	0	Pass
NVNT	2-DH1	2402	1.0415	1.1064	0	Pass
NVNT	2-DH1	2441	1.0473	1.0856	0	Pass
NVNT	2-DH1	2480	1.0633	1.0992	0	Pass
NVNT	3-DH1	2402	1.1089	1.151	0	Pass
NVNT	3-DH1	2441	1.0403	1.137	0	Pass
NVNT	3-DH1	2480	1.1087	1.155	0	Pass

OBW NVNT 1-DH1 2402MHz

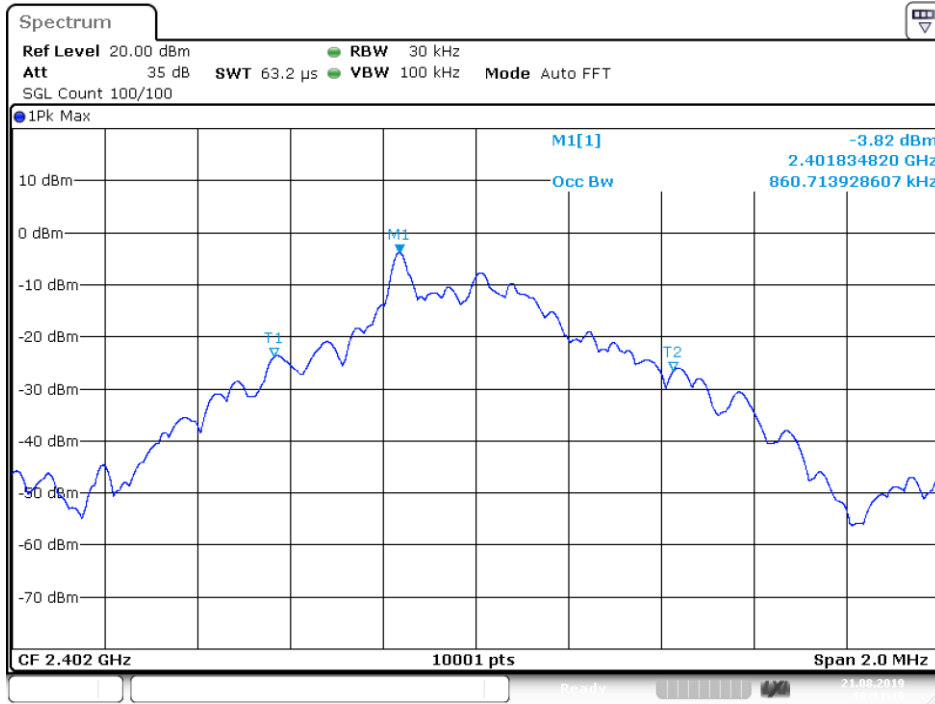

-20 dB BW NVNT 1-DH1 2402MHz

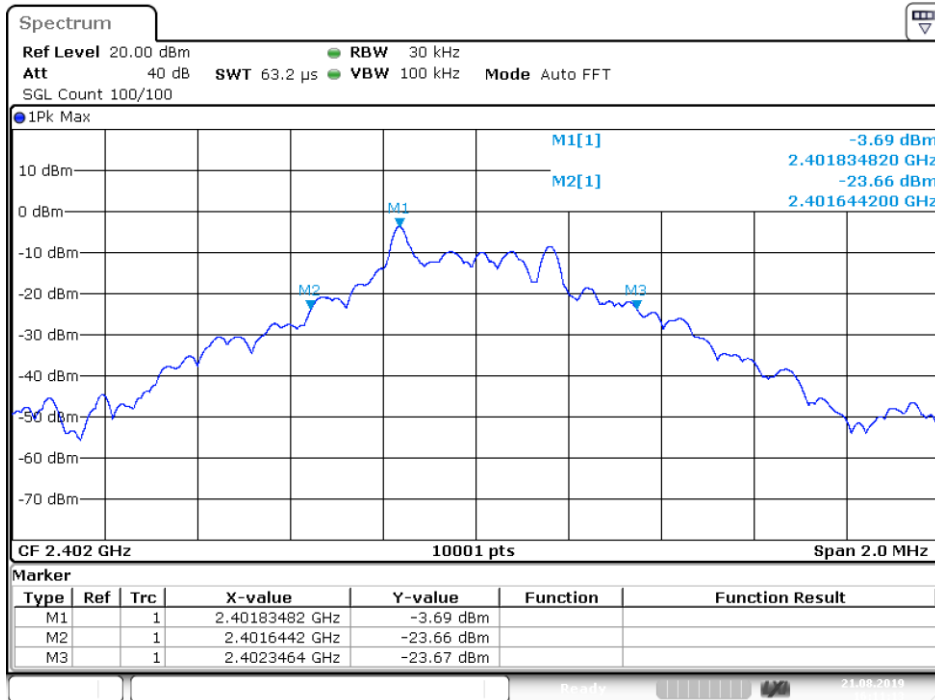

OBW NVNT 1-DH1 2441MHz

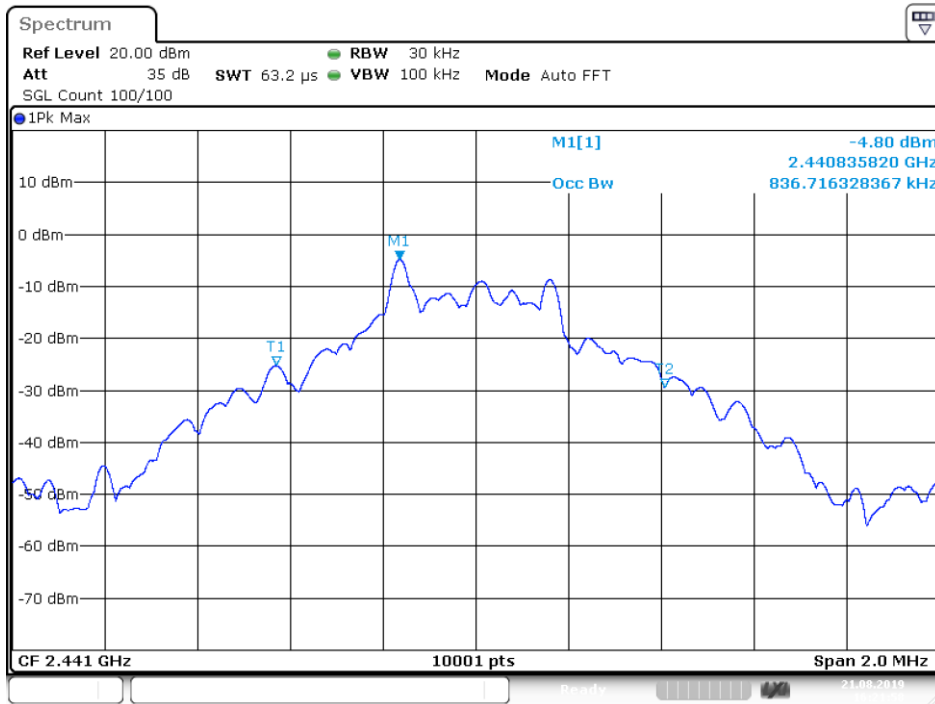

Date: 21.AUG.2019 16:21:58

-20 dB BW NVNT 1-DH1 2441MHz

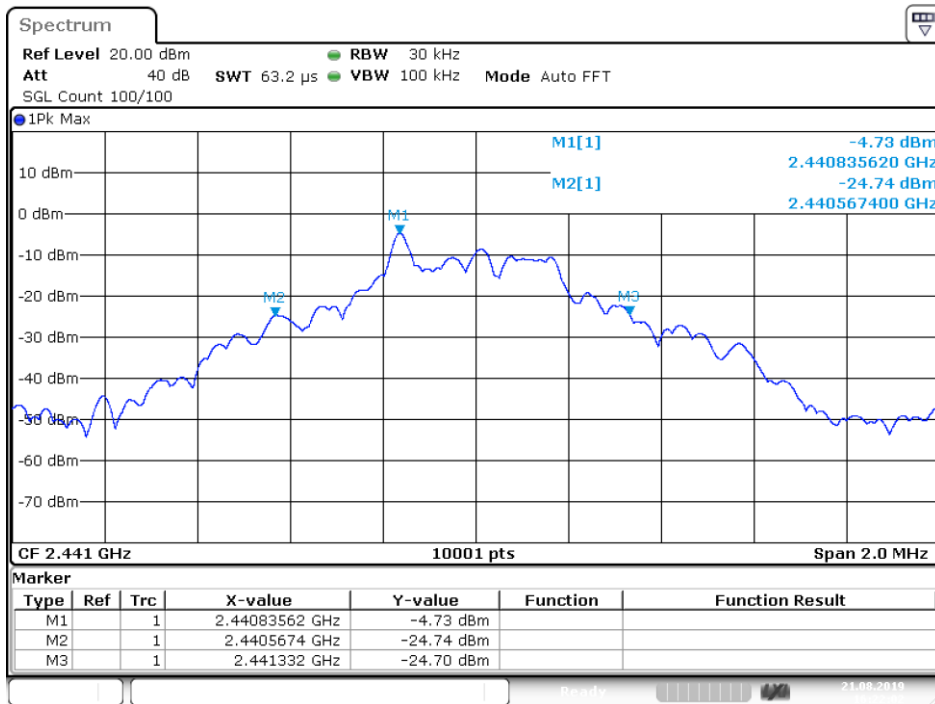

Date: 21.AUG.2019 16:22:02

OBW NVNT 1-DH1 2480MHz

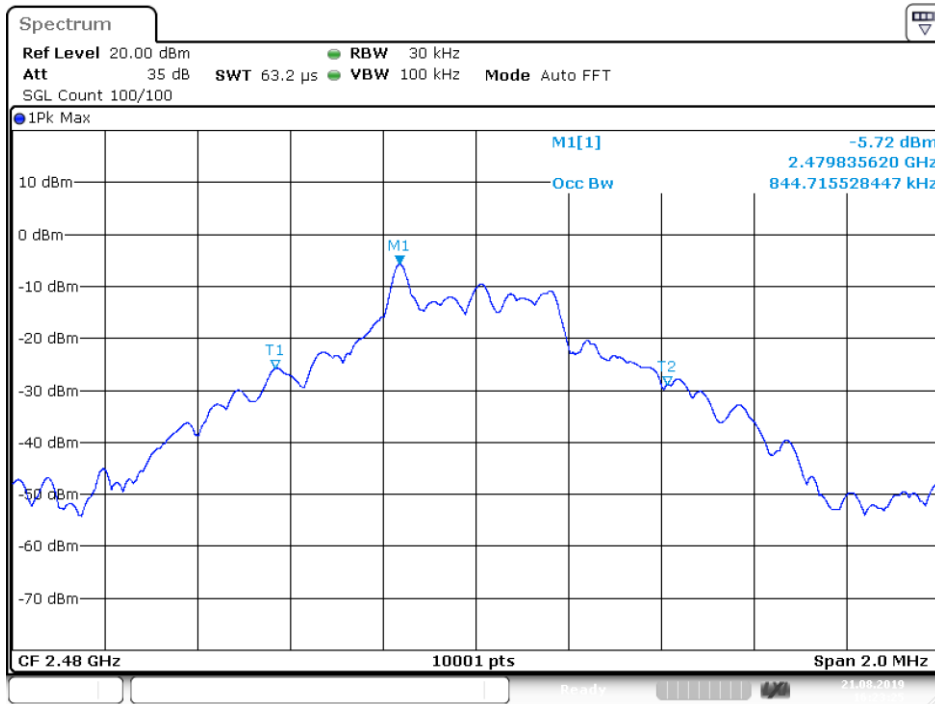

Date: 21.AUG.2019 16:23:25

-20 dB BW NVNT 1-DH1 2480MHz

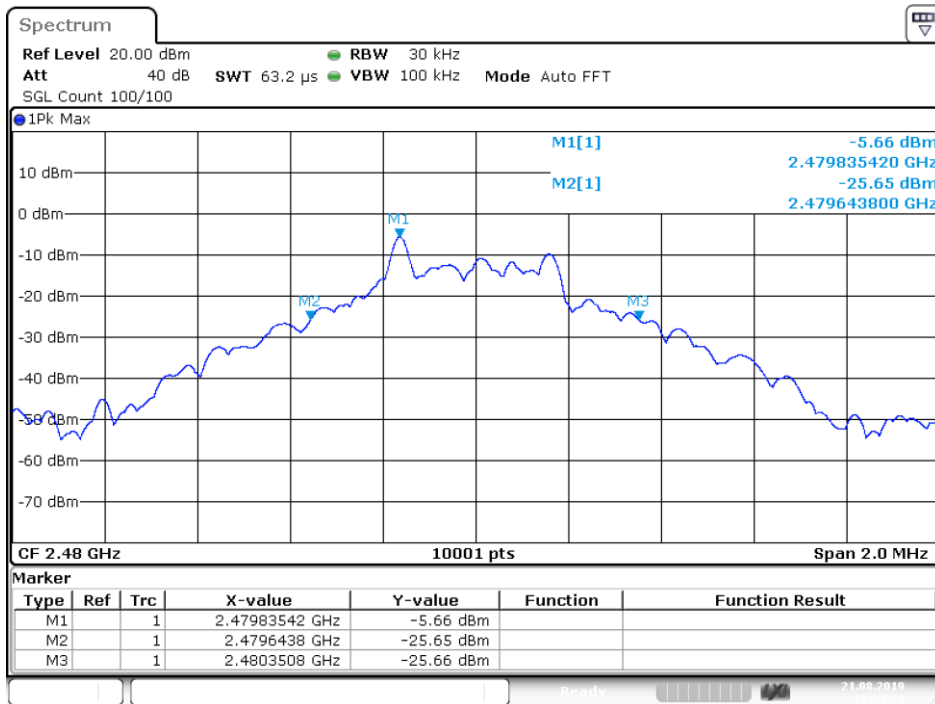

Date: 21.AUG.2019 16:23:29

5. CARRIER FREQUENCY SEPARATION

5.1.Limit

Frequency hopping systems shall have hopping channel carrier frequencies separated by a minimum of 25 kHz or the 20 dB bandwidth of the hopping channel, whichever is greater. Alternatively, frequency hopping systems operating in the 2400-2483.5 MHz band may have hopping channel carrier frequencies that are separated by 25 kHz or two-thirds of the 20 dB bandwidth of the hopping channel, whichever is greater, provided the systems operate with an output power no greater than 125 mW

5.2.Test Procedure

The RF output of EUT was connected to the spectrum analyzer by RF cable and attenuator. The carrier frequency was measured by spectrum analyzer with 20kHz RBW and 62kHz VBW.

5.3.Test Result

Condition	Mode	Hopping Freq1 (MHz)	Hopping Freq2 (MHz)	HFS (MHz)	Limit (MHz)	Verdict
NVNT	1-DH1	2401.834	2402.833	0.999	0.468	Pass
NVNT	1-DH1	2440.834	2441.836	1.002	0.468	Pass
NVNT	1-DH1	2478.834	2479.833	0.999	0.468	Pass
NVNT	2-DH1	2401.834	2402.839	1.005	0.471	Pass
NVNT	2-DH1	2441.122	2441.836	0.714	0.471	Pass
NVNT	2-DH1	2478.837	2480.121	1.284	0.471	Pass
NVNT	3-DH1	2401.837	2402.995	1.158	0.733	Pass
NVNT	3-DH1	2440.996	2441.995	0.999	0.733	Pass
NVNT	3-DH1	2478.84	2479.995	1.155	0.733	Pass

CFS NVNT 1-DH1 2402MHz

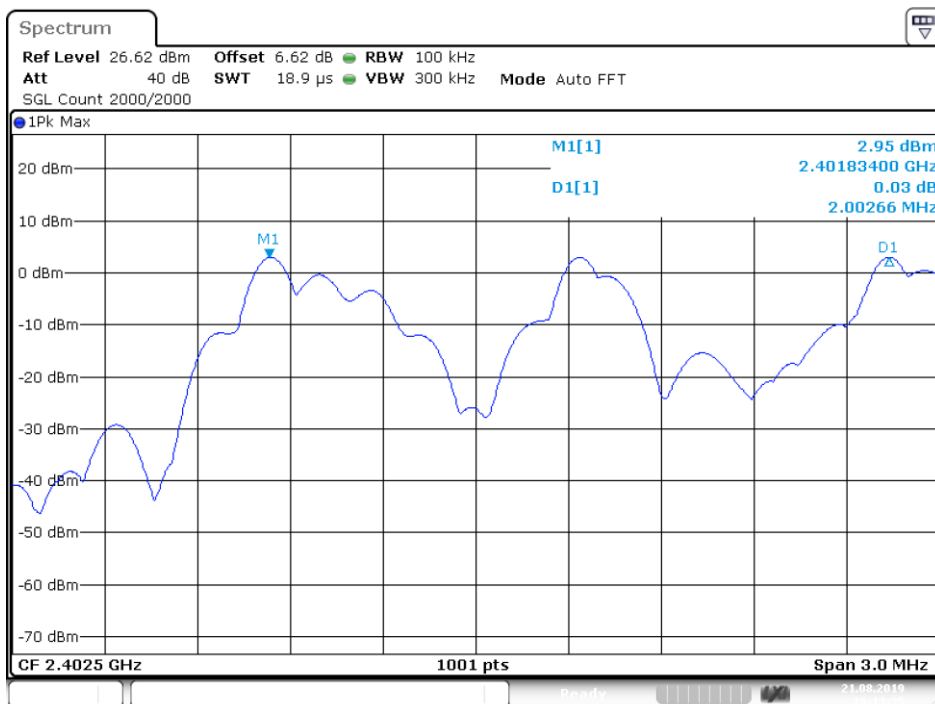

Date: 21.AUG.2019 16:13:35

CFS NVNT 1-DH1 2441MHz

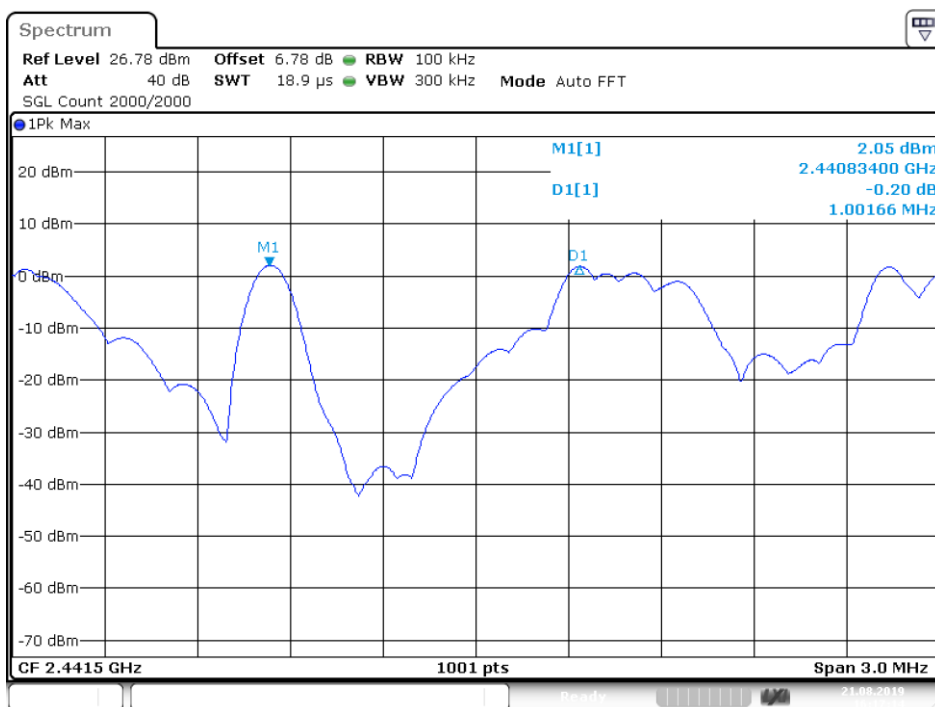

Date: 21.AUG.2019 16:17:14

CFS NVNT 1-DH1 2480MHz

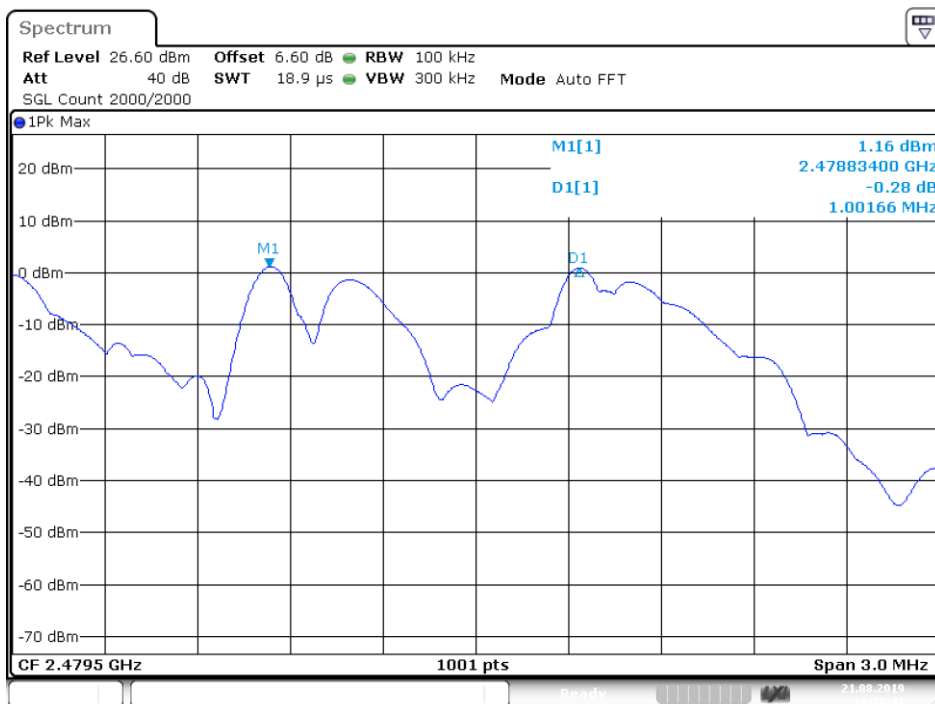

Date: 21.AUG.2019 16:18:41

CFS NVNT 2-DH1 2402MHz

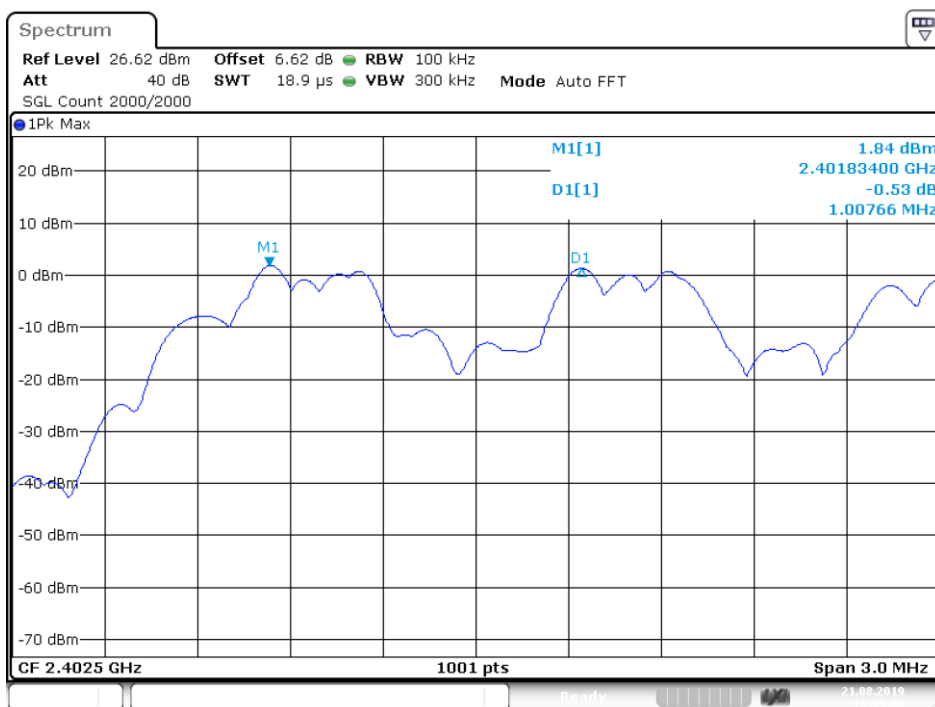

Date: 21.AUG.2019 16:39:06

CFS NVNT 2-DH1 2441MHz

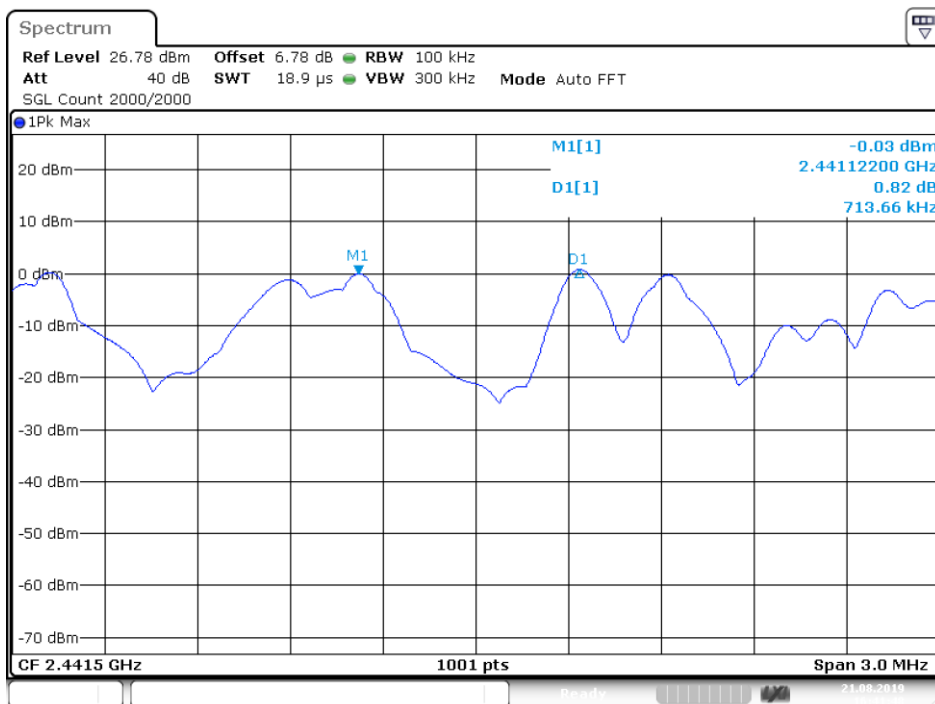

Date: 21.AUG.2019 16:41:48

CFS NVNT 2-DH1 2480MHz

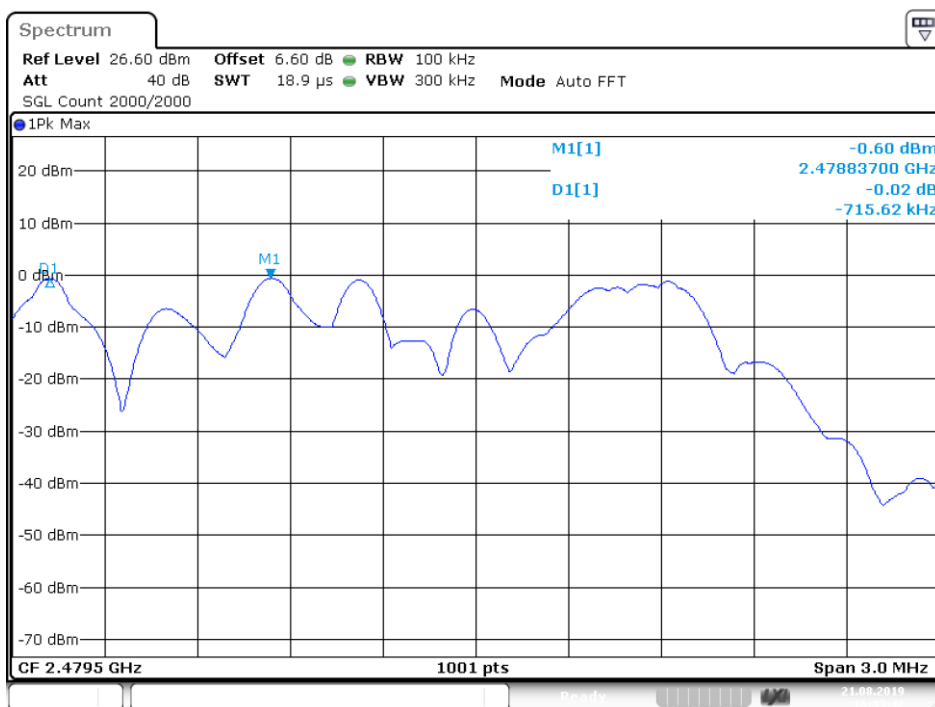

Date: 21.AUG.2019 16:43:42

CFS NVNT 3-DH1 2402MHz

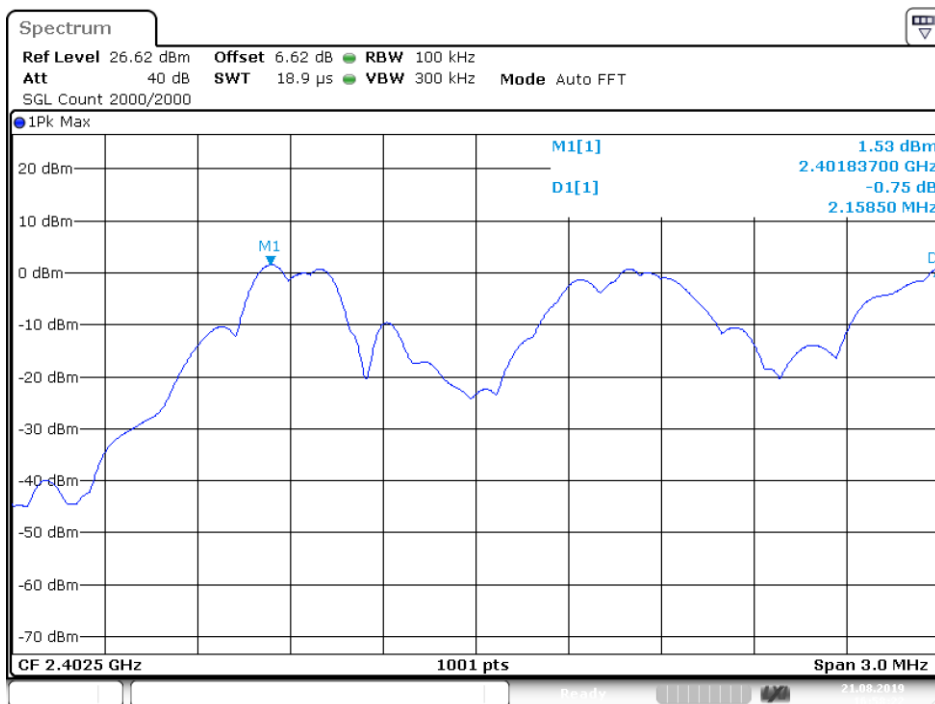

Date: 21.AUG.2019 16:58:22

CFS NVNT 3-DH1 2441MHz

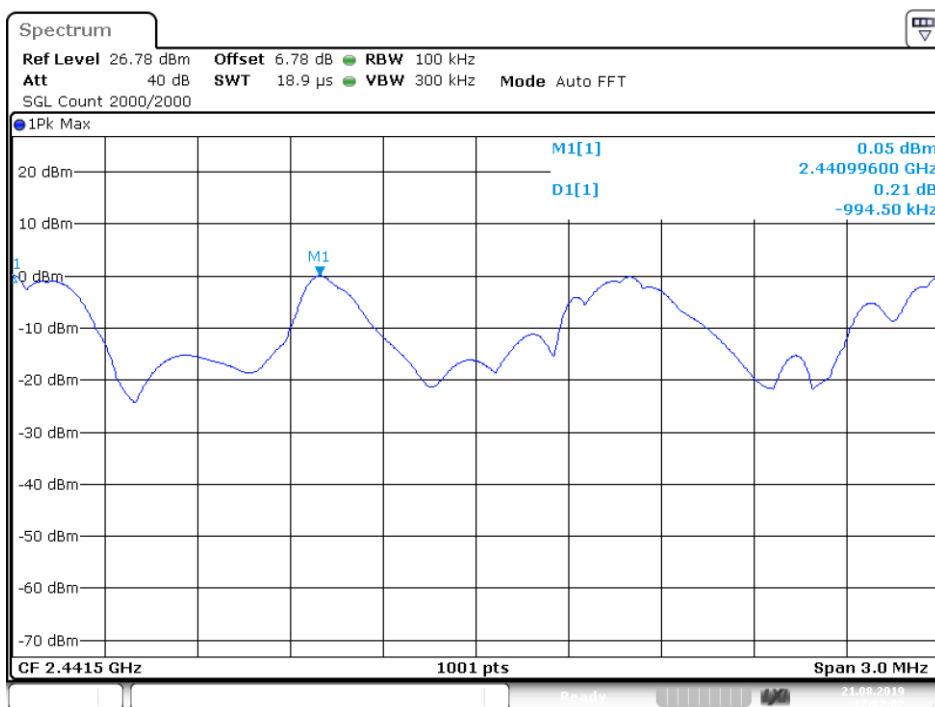

Date: 21.AUG.2019 17:02:02

CFS NVNT 3-DH1 2480MHz

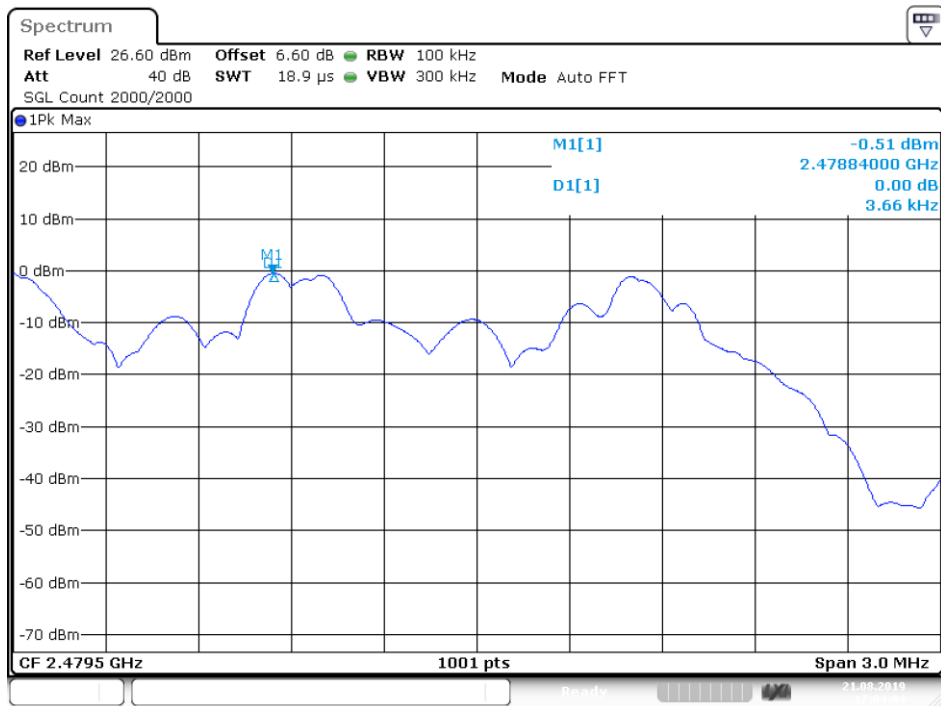

Date: 21.AUG.2019 17:04:04

6. NUMBER OF HOPPING CHANNEL

6.1.Limit

Frequency hopping systems in the 2400-2483.5 MHz band shall use at least 15 channels

6.2.Test Procedure

The RF output of EUT was connected to the spectrum analyzer by RF cable and attenuator. The number of hopping channel was measured by spectrum analyzer with 100kHz RBW and 300KHz VBW.

6.3.Test Result

Condition	Mode	Hopping Number	Limit	Verdict
NVNT	1-DH1	79	15	Pass
NVNT	1-DH1	79	15	Pass
NVNT	1-DH1	79	15	Pass
NVNT	2-DH1	79	15	Pass
NVNT	2-DH1	79	15	Pass
NVNT	2-DH1	79	15	Pass
NVNT	3-DH1	79	15	Pass
NVNT	3-DH1	79	15	Pass
NVNT	3-DH1	79	15	Pass

Hopping No. NVNT 1-DH1 2402MHz

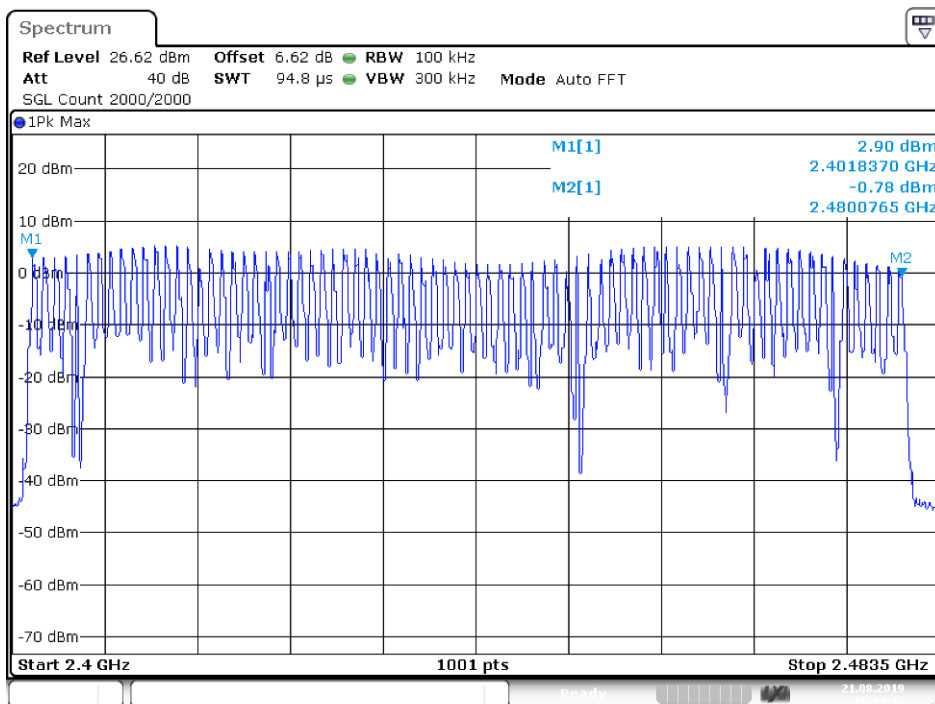

Hopping No. NVNT 1-DH1 2441MHz

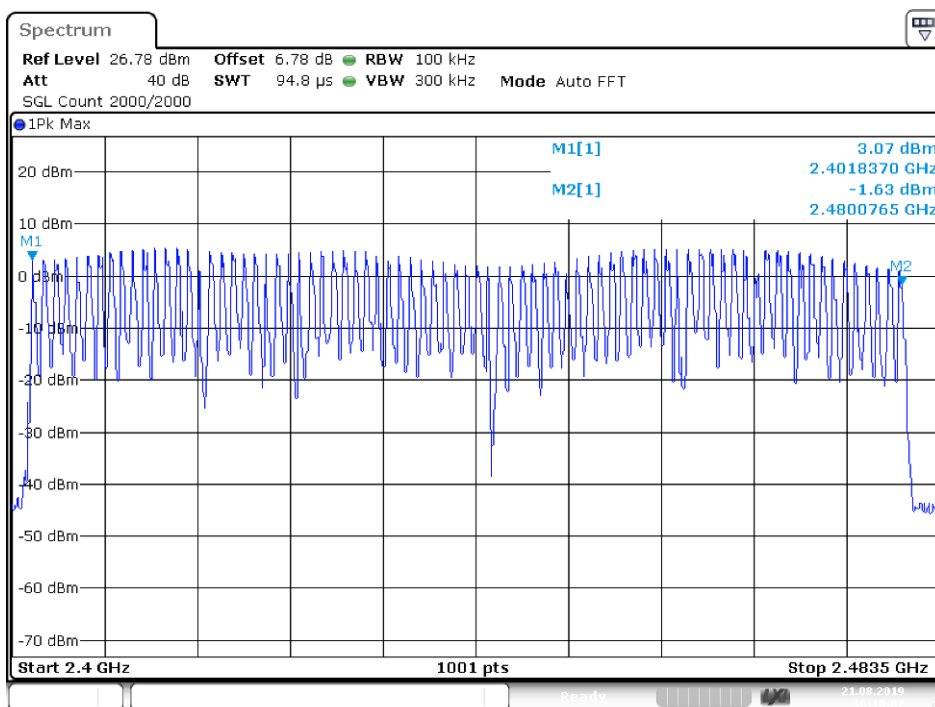

Hopping No. NVNT 1-DH1 2480MHz

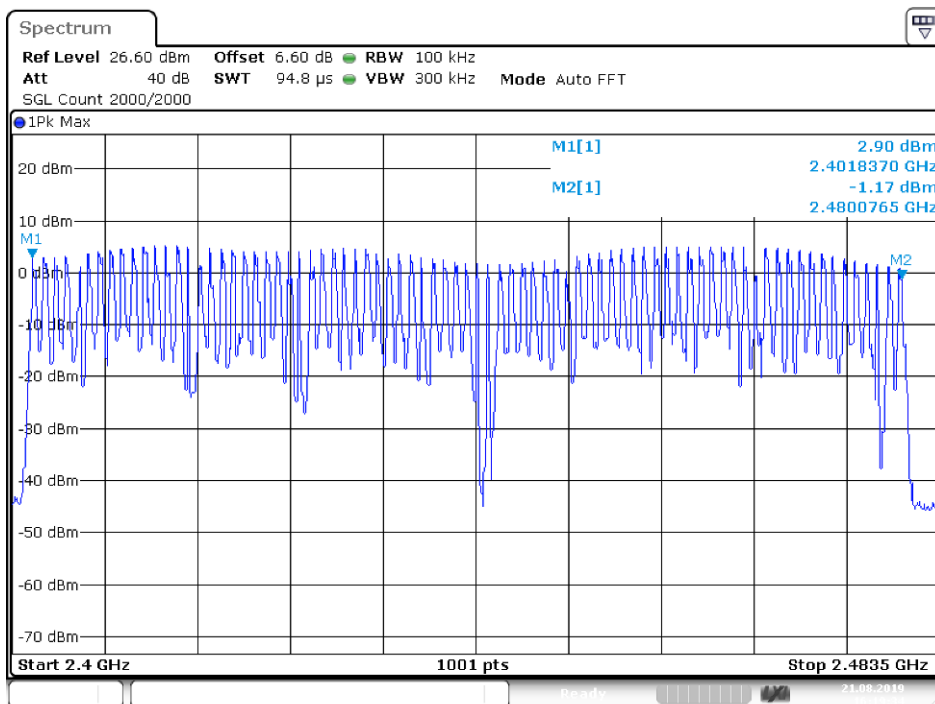

Date: 21.AUG.2019 16:19:35

Hopping No. NVNT 2-DH1 2402MHz

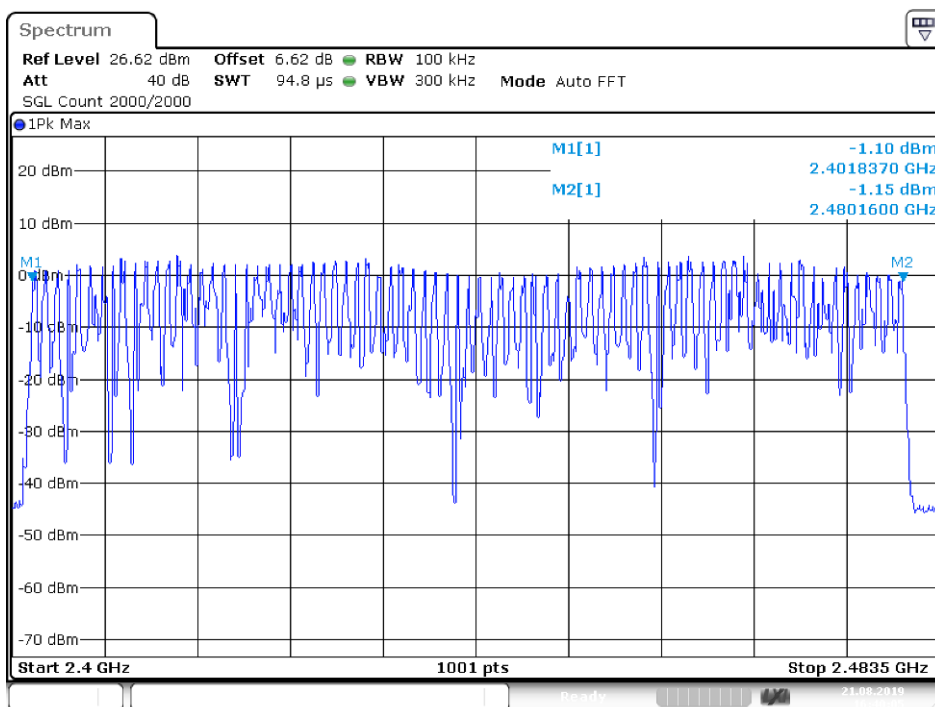

Date: 21.AUG.2019 16:40:05

Hopping No. NVNT 2-DH1 2441MHz

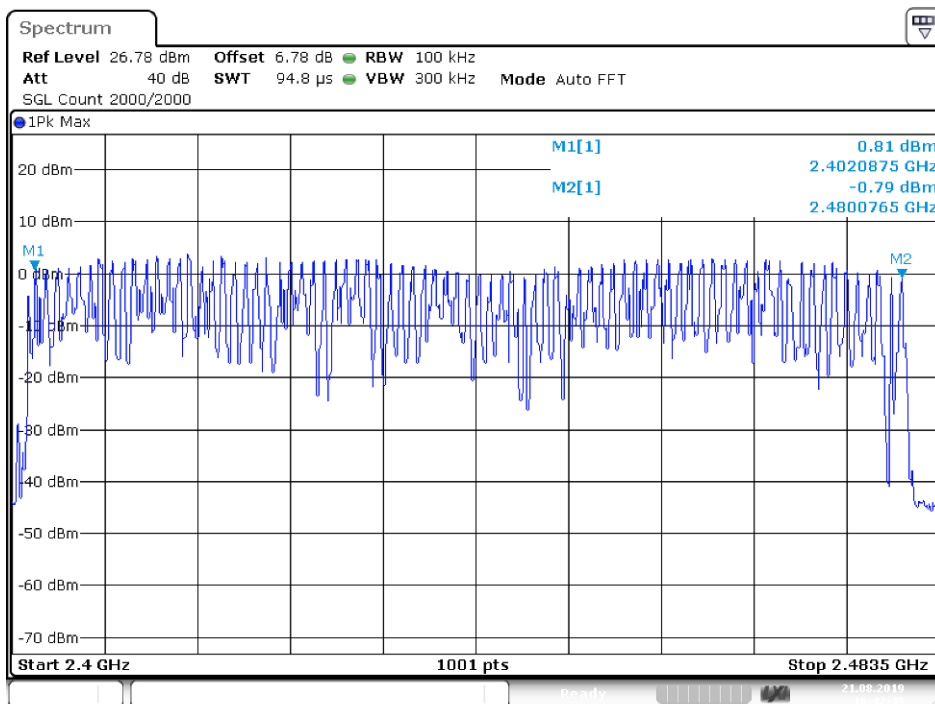

Date: 21.AUG.2019 16:42:49

Hopping No. NVNT 2-DH1 2480MHz

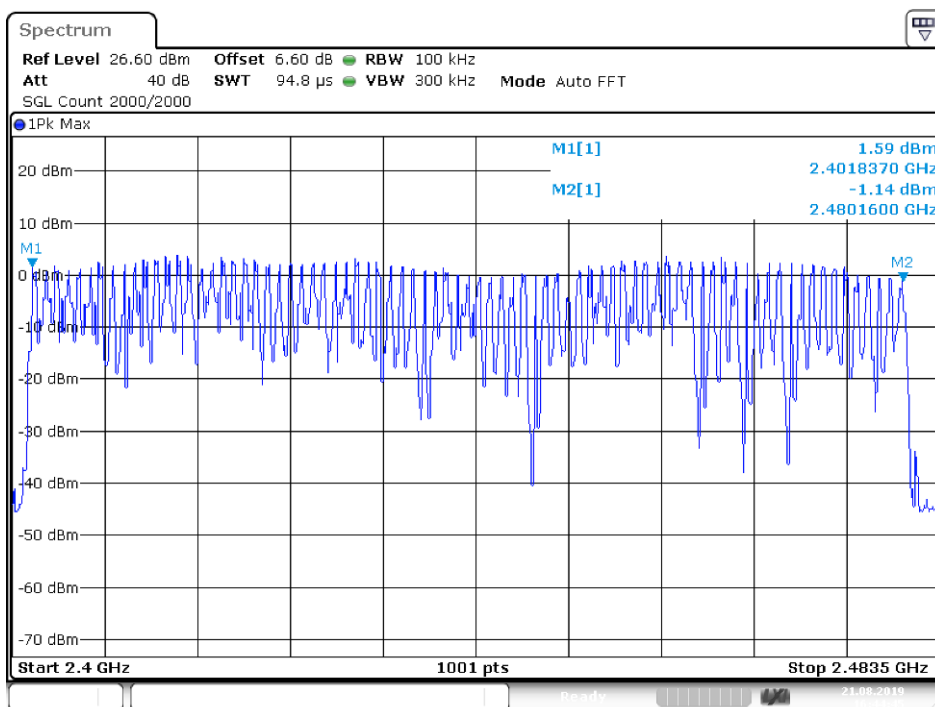

Date: 21.AUG.2019 16:44:44

Hopping No. NVNT 3-DH1 2402MHz

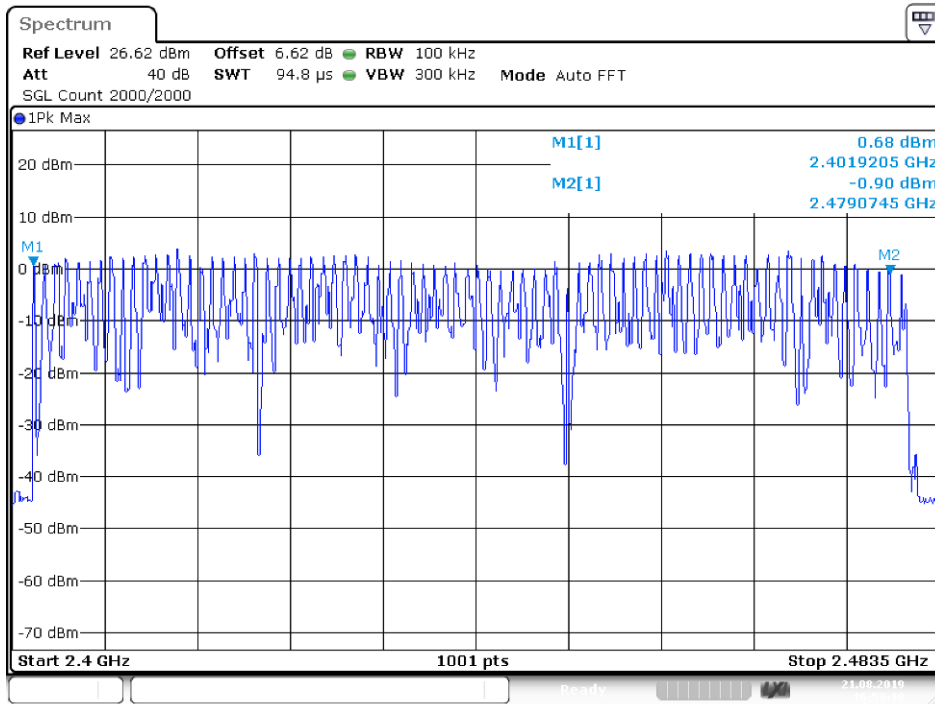

Hopping No. NVNT 3-DH1 2441MHz

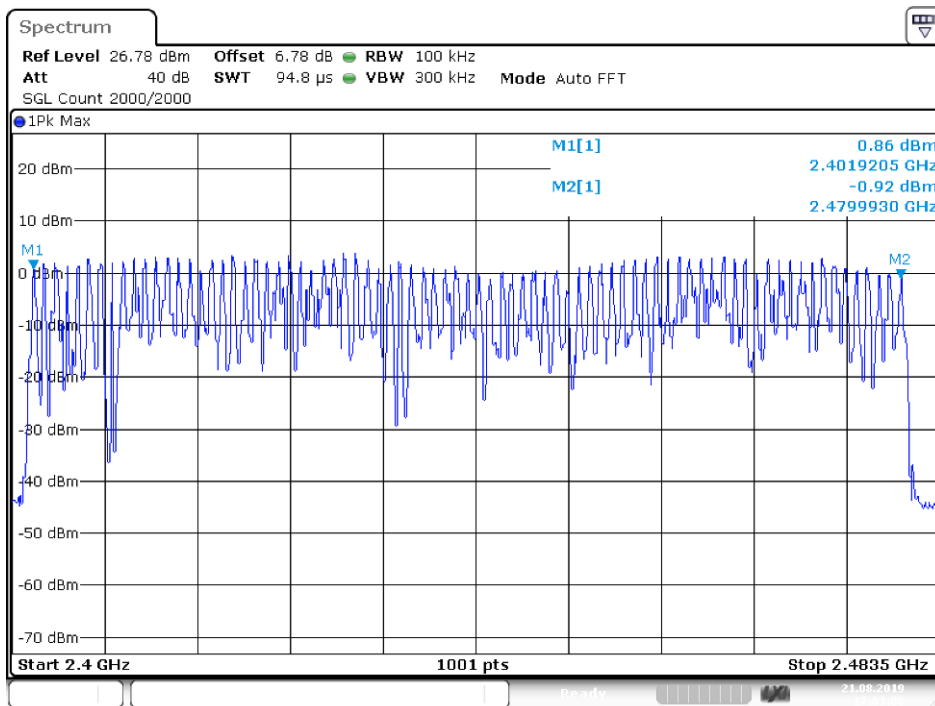

Hopping No. NVNT 3-DH1 2480MHz

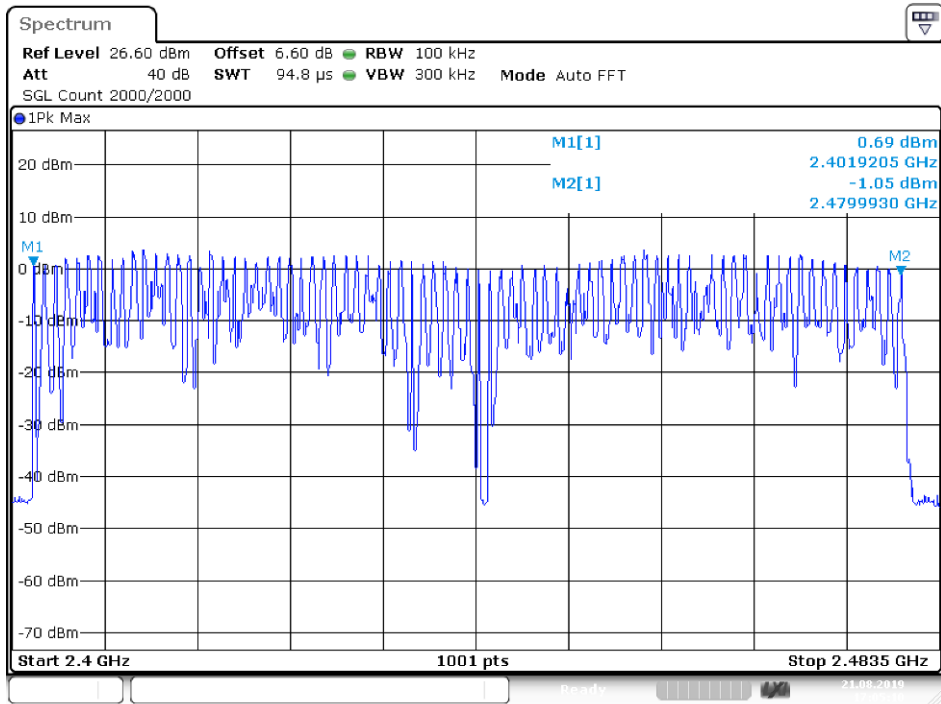

Date: 21.AUG.2019 17:05:10

7. DWELL TIME

7.1. Test limit

Please refer section 15.247

According to §15.247(a)(1)(iii), Frequency hopping systems operating in the 2400MHz-2483.5 MHz. The average time of occupancy on any frequency shall not be greater than 0.4 s within period of 0.4 seconds multiplied by the number of hopping channels employed.

7.2. Test Procedure

7.2.1. Place the EUT on the table and set it in transmitting mode.

7.2.2. Remove the antenna from the EUT and then connect a low loss RF cable from the antenna port to the spectrum analyzer.

7.2.3. Set center frequency of spectrum analyzer = operating frequency.

7.2.4. Set the spectrum analyzer as RBW=1MHz, VBW=1MHz, Span = 0Hz, Sweep = auto.

7.2.5. Repeat above procedures until all frequency measured were complete.

7.3. Test Result

PASS.

Condition	Mode	Frequency (MHz)	Pulse Time (ms)	Total Dwell Time (ms)	Period Time (ms)	Limit (ms)	Verdict
NVNT	1-DH1	2402	0.37	116.888	31600	400	Pass
NVNT	1-DH1	2441	0.37	116.888	31600	400	Pass
NVNT	1-DH1	2480	0.37	116.794	31600	400	Pass
NVNT	2-DH1	2402	0.374	118.31	31600	400	Pass
NVNT	2-DH1	2441	0.377	119.164	31600	400	Pass
NVNT	2-DH1	2480	0.377	119.069	31600	400	Pass
NVNT	3-DH1	2402	0.378	119.448	31600	400	Pass
NVNT	3-DH1	2441	0.378	119.448	31600	400	Pass
NVNT	3-DH1	2480	0.378	119.448	31600	400	Pass

Dwell NVNT 1-DH1 2402MHz

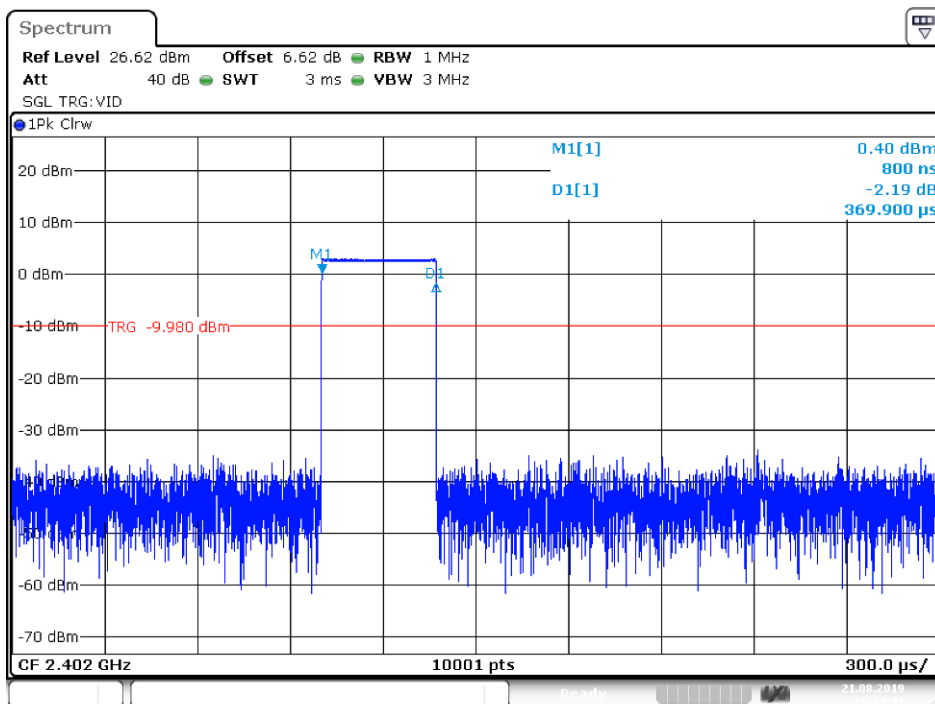

Date: 21.AUG.2019 16:14:41

Dwell NVNT 1-DH1 2441MHz

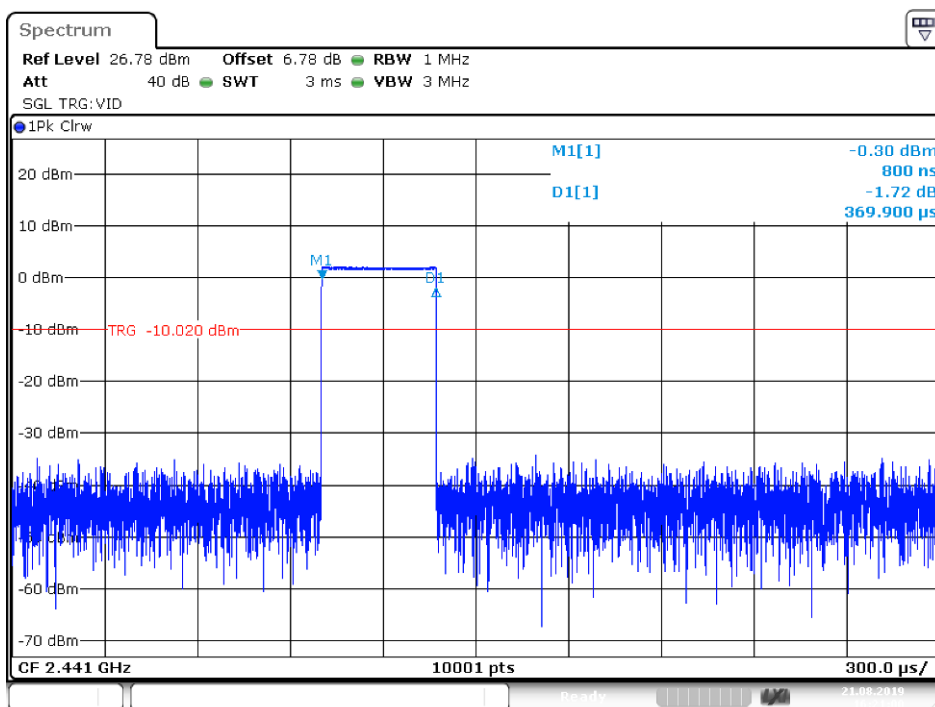

Date: 21.AUG.2019 16:21:00

Dwell NVNT 1-DH1 2480MHz

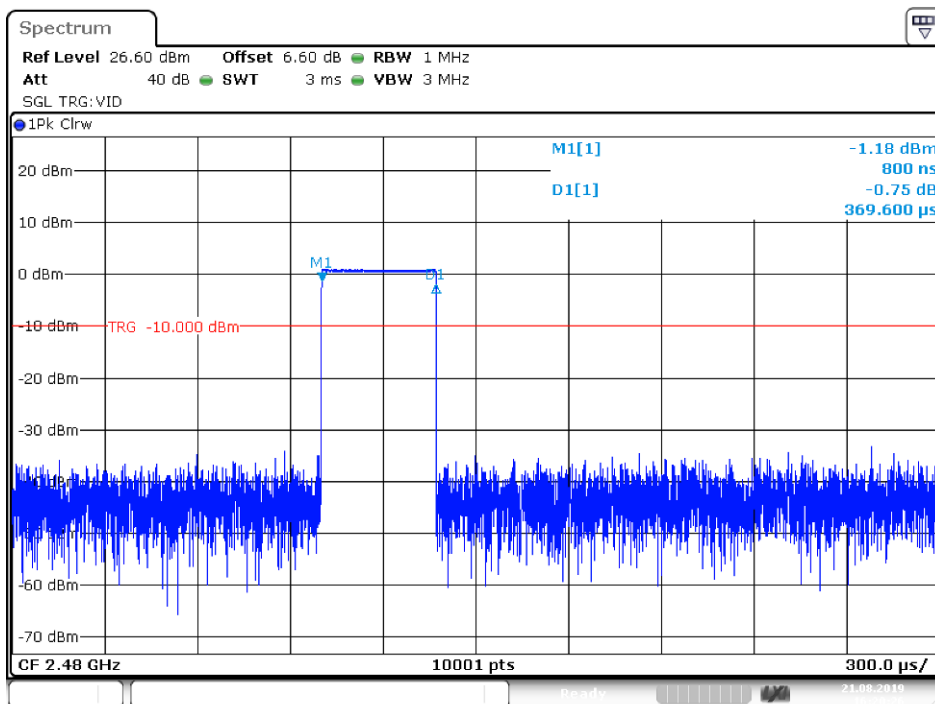

Date: 21.AUG.2019 16:20:26

Dwell NVNT 2-DH1 2402MHz

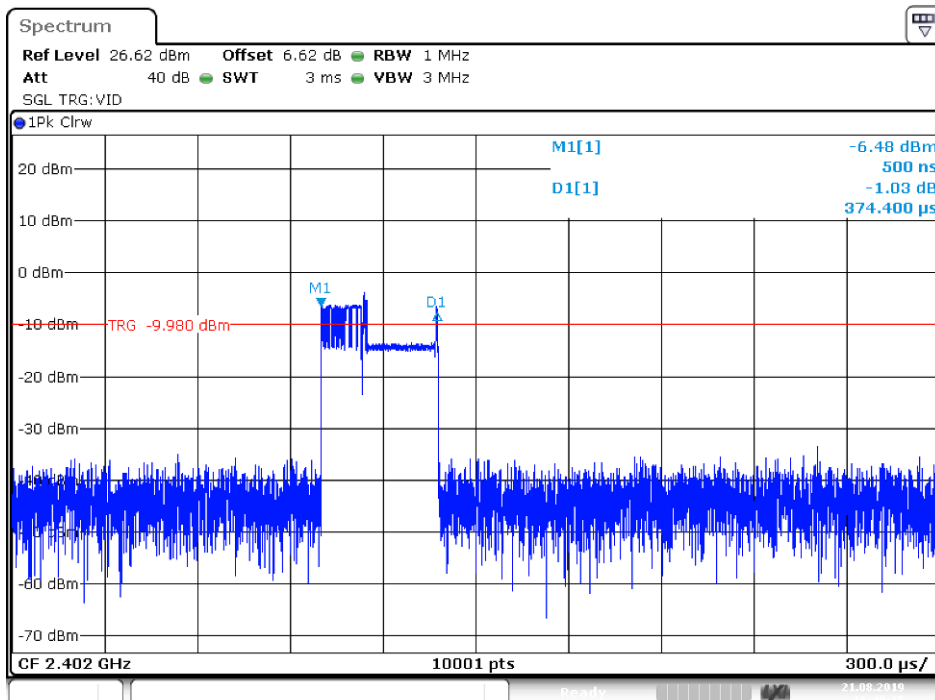

Date: 21.AUG.2019 16:40:16

Dwell NVNT 2-DH1 2441MHz

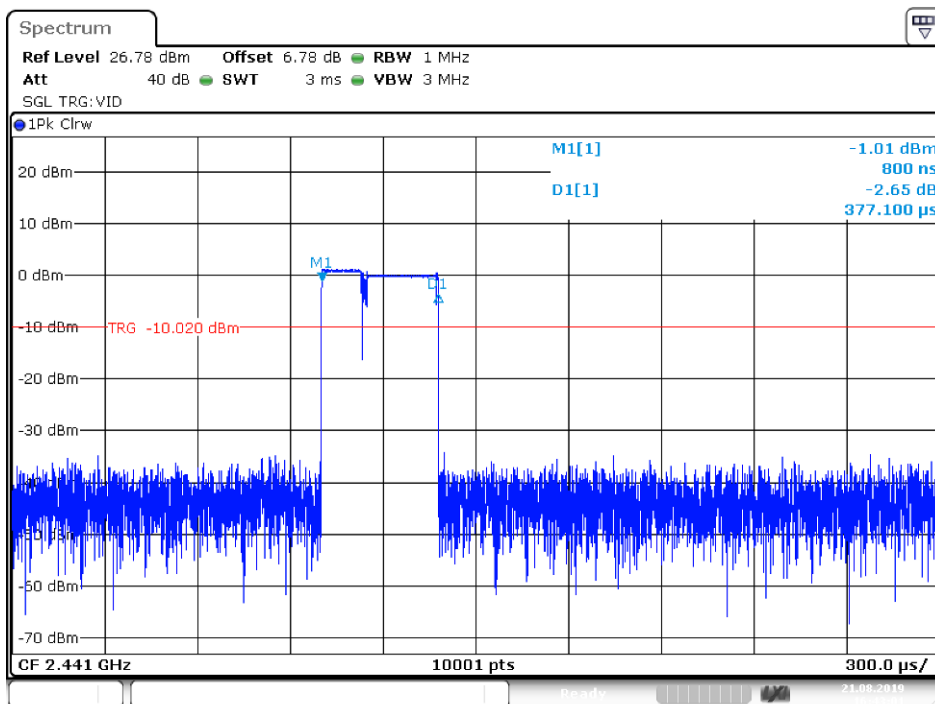

Date: 21.AUG.2019 16:43:01

Dwell NVNT 2-DH1 2480MHz

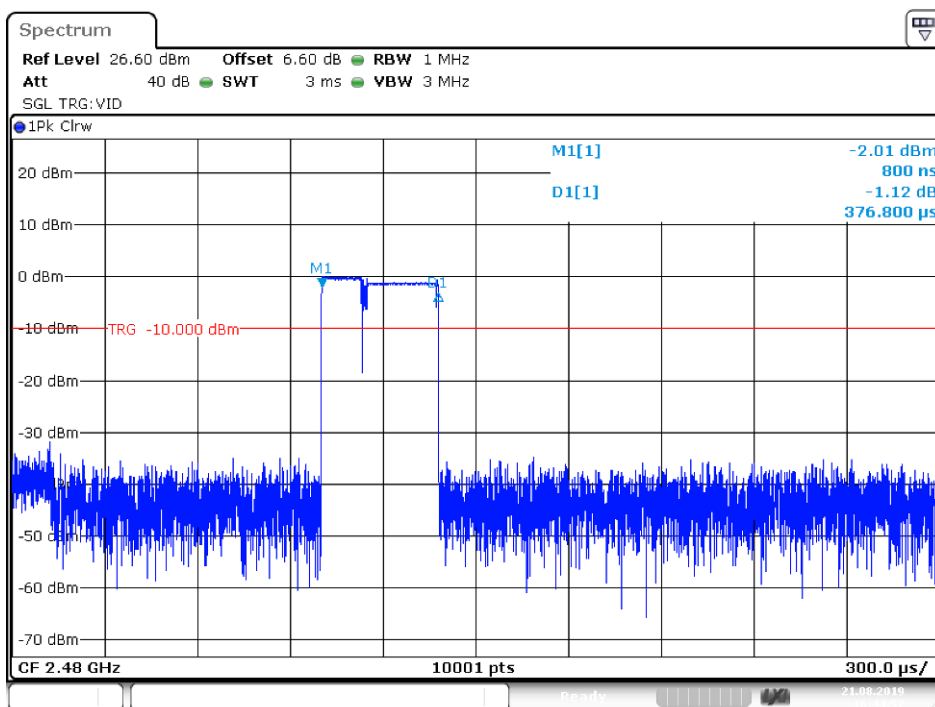

Date: 21.AUG.2019 16:44:57

Dwell NVNT 3-DH1 2402MHz

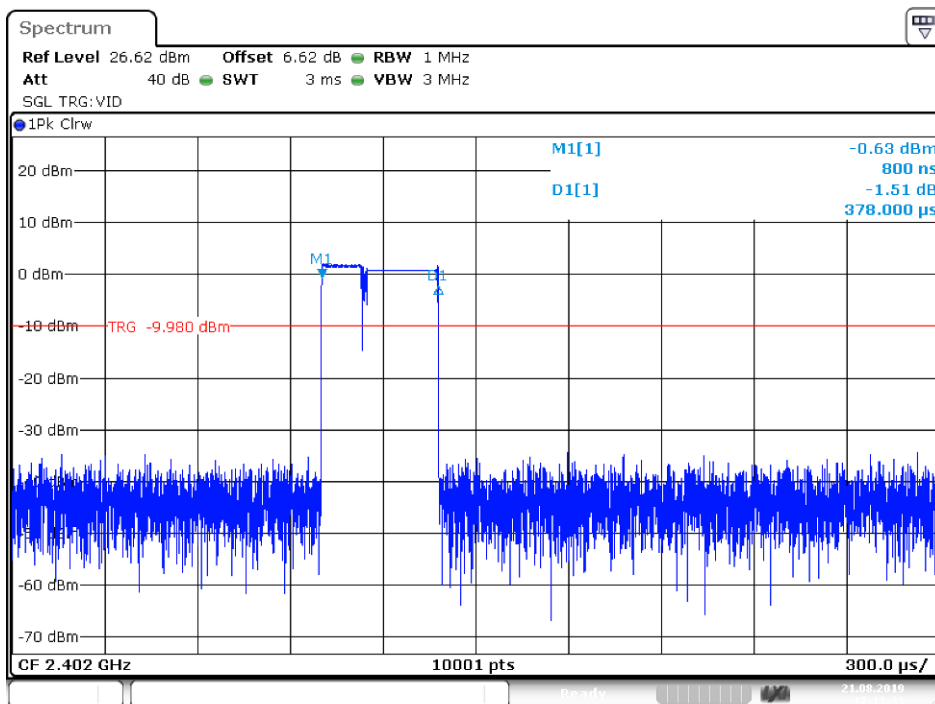

Date: 21.AUG.2019 17:13:34

Dwell NVNT 3-DH1 2441MHz

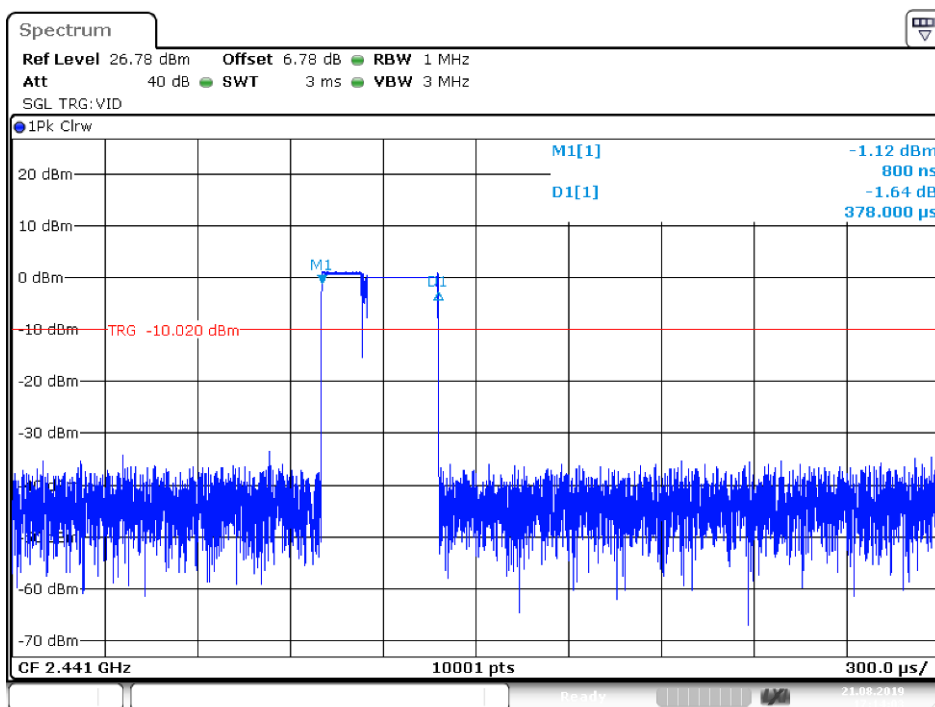

Date: 21.AUG.2019 17:14:03

Dwell NVNT 3-DH1 2480MHz

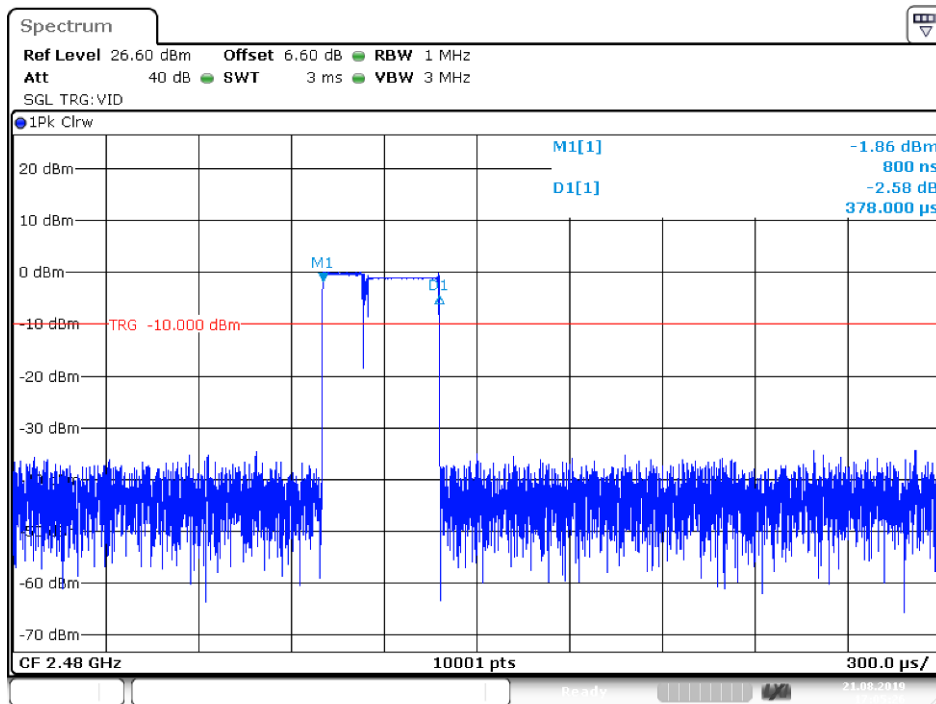

Date: 21.AUG.2019 17:05:26

8. RADIATED EMISSIONS

8.1.Limit

All the emissions appearing within 15.205 restricted frequency bands shall not exceed the limits shown in 15.209, all the other emissions shall be at least 20dB below the fundamental emissions, or comply with 15.209 limits.

15.205 Restricted frequency band

MHz	MHz	MHz	GHz
0.090 - 0.110	16.42 - 16.423	399.9 - 410	4.5 - 5.15
¹ 0.495 - 0.505	16.69475 - 16.69525	608 - 614	5.35 - 5.46
2.1735 - 2.1905	16.80425 - 16.80475	960 - 1240	7.25 - 7.75
4.125 - 4.128	25.5 - 25.67	1300 - 1427	8.025 - 8.5
4.17725 - 4.17775	37.5 - 38.25	1435 - 1626.5	9.0 - 9.2
4.20725 - 4.20775	73 - 74.6	1645.5 - 1646.5	9.3 - 9.5
6.215 - 6.218	74.8 - 75.2	1660 - 1710	10.6 - 12.7
6.26775 - 6.26825	108 - 121.94	1718.8 - 1722.2	13.25 - 13.4
6.31175 - 6.31225	123 - 138	2200 - 2300	14.47 - 14.5
8.291 - 8.294	149.9 - 150.05	2310 - 2390	15.35 - 16.2
8.362 - 8.366	156.52475 - 156.52525	2483.5 - 2500	17.7 - 21.4
8.37625 - 8.38675	156.7 - 156.9	2690 - 2900	22.01 - 23.12
8.41425 - 8.41475	162.0125 - 167.17	3260 - 3267	23.6 - 24.0
12.29 - 12.293	167.72 - 173.2	3332 - 3339	31.2 - 31.8
12.51975 - 12.52025	240 - 285	3345.8 - 3358	36.43 - 36.5
12.57675 - 12.57725	322 - 335.4	3600 - 4400	(²)

15.209 Limit

FREQUENCY MHz	DISTANCE Meters	FIELD STRENGTHS LIMIT	
		$\mu\text{V}/\text{m}$	$\text{dB}(\mu\text{V})/\text{m}$
0.009-0.490	300	2400/F(KHz)	/
0.490-1.705	30	24000/F(KHz)	/
1.705-30	30	30	29.5
30 ~ 88	3	100	40.0
88 ~ 216	3	150	43.5
216 ~ 960	3	200	46.0
960 ~ 1000	3	500	54.0
Above 1000	3	74.0 dB(μV)/m (Peak) 54.0 dB(μV)/m (Average)	

8.2. Block Diagram of Test setup

8.2.1 In 3m Anechoic Chamber Test Setup Diagram for below 30MHz

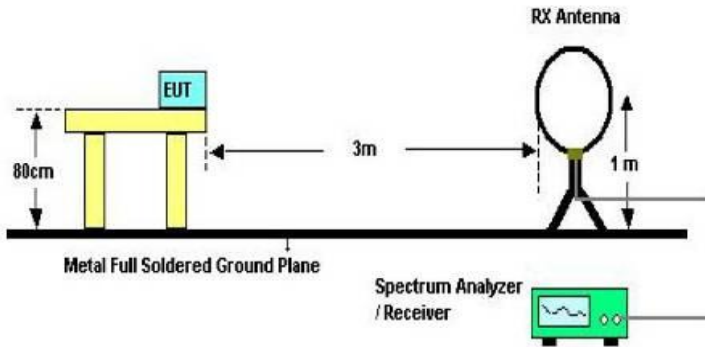

8.2.1 In 3m Anechoic Chamber Test Setup Diagram for below 1GHz

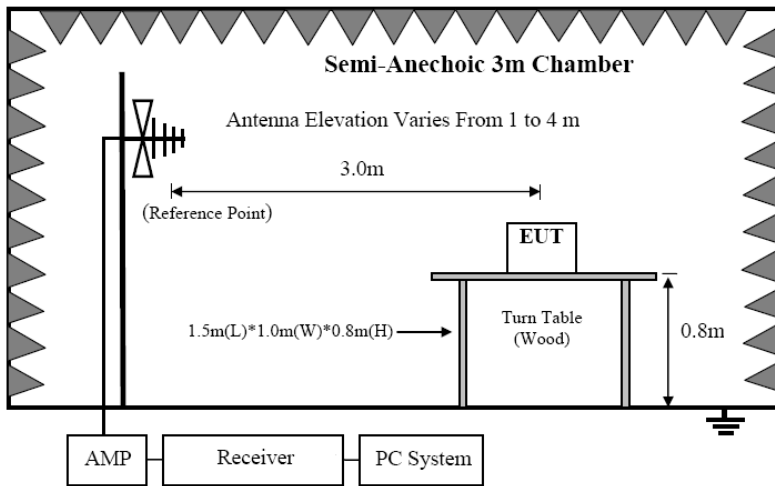

8.2.2 In 3m Anechoic Chamber Test Setup Diagram for frequency above 1GHz

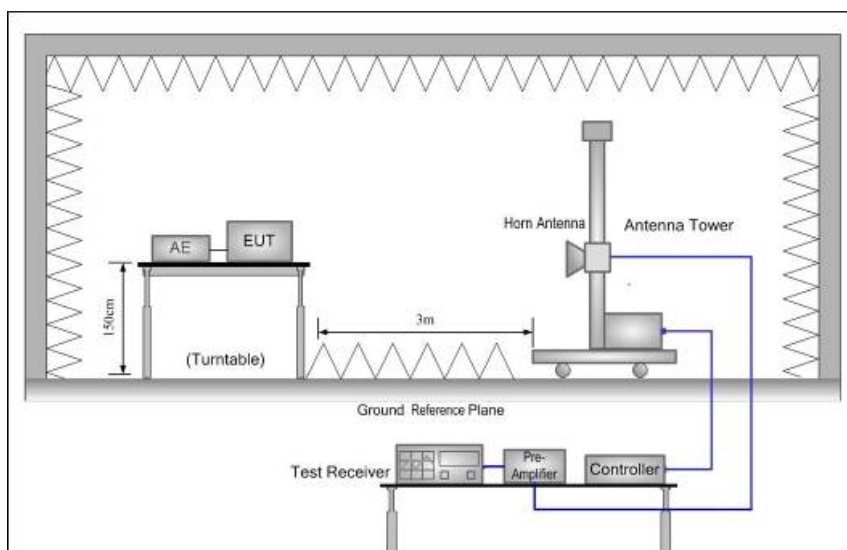

Note: For harmonic emissions test a appropriate high pass filter was inserted in the input port of AMP.

8.3. Test Procedure

- (1) EUT was placed on a non-metallic table, 80 cm above the ground plane inside a semi-anechoic chamber.
- (2) Setup EUT and simulator as shown in section 1.4 and 6.1
- (3) Test antenna was located 3m from the EUT on an adjustable mast. Below pre-scan procedure was first performed in order to find prominent radiated emissions.
 - (a) Change work frequency or channel of device if practicable.
 - (b) Change modulation type of device if practicable.
 - (c) Rotated EUT though three orthogonal axes to determine the attitude of EUT arrangement produces highest emissions
- (4) Spectrum frequency from 9KHz to 25GHz (tenth harmonic of fundamental frequency) was investigated
- (5) For final emissions measurements at each frequency of interest, the EUT were rotated and the antenna height was varied between 1m and 4m in order to maximize the emission. Measurements in both horizontal and vertical polarities were made and the data was recorded. In order to find the maximum emission, the relative positions of equipments and all of the interface cables were changed according to ANSI C63.10 :2013on Radiated Emission test.
- (6) For emissions above 1GHz, both Peak and Average level were measured with Spectrum Analyzer, and the RBW is set at 1MHz, VBW is set at 3MHz for Peak measure; RBW is set at 1MHz, VBW is set at 10Hz for Average measure.

8.4. Test Result

We have scanned the 10th harmonic from 9KHz to the EUT's highest frequency..
Detailed information please see the following page.

From 9KHz to 30MHz: Conclusion: PASS

Note: The amplitude of spurious emissions which are attenuated by more than 20dB below the permissible value has no need to be reported.

From 30MHz to 1000MHz: Conclusion: PASS			
EUT Description	Smart handheld printer	Model No.	XPOS-I100
Temperature	24°C	Humidity	56%
Pol	Vertical	Test date	2019/7/19
Test Voltage	DC 3.8V	Test mode	GFSK (2402MHz)

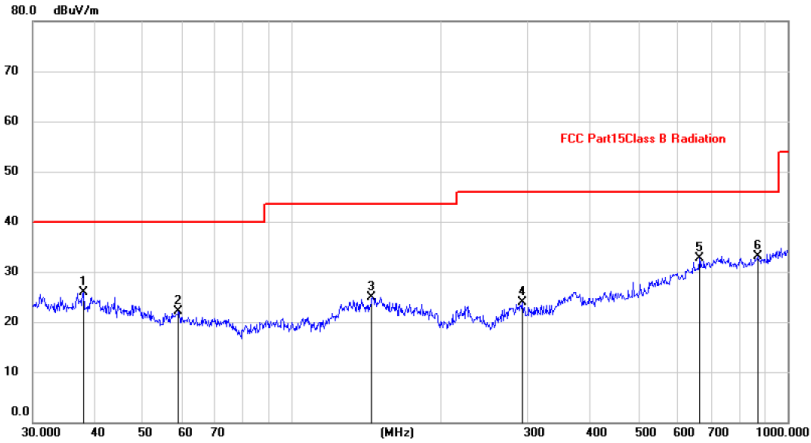

No. Mk.	Freq.	Reading Level	Correct Factor	Measurement	Limit	Margin	Antenna Height	Table Degree
	MHz	dBuV	dB	dBuV/m	dBuV/m	dB	cm	degree
1	38.0782	11.78	14.14	25.92	40.00	-14.08	peak	
2	59.0251	8.77	13.25	22.02	40.00	-17.98	peak	
3	145.3505	10.24	14.71	24.95	43.50	-18.55	peak	
4	291.0360	9.94	13.90	23.84	46.00	-22.16	peak	
5	665.8034	11.49	21.28	32.77	46.00	-13.23	peak	
6 *	869.1300	9.39	23.64	33.03	46.00	-12.97	peak	

Pol	Horizontal
------------	------------

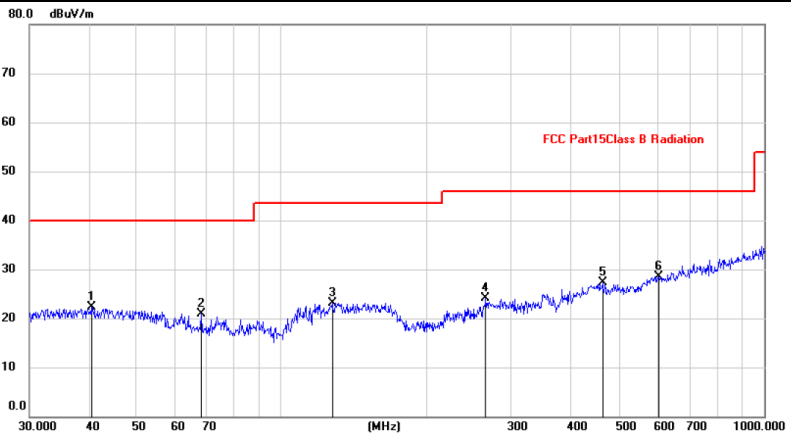

No. Mk.	Freq.	Reading Level	Correct Factor	Measurement	Limit	Margin	Antenna Height	Table Degree
	MHz	dBuV	dB	dBuV/m	dBuV/m	dB	cm	degree
1	40.4170	7.81	14.41	22.22	40.00	-17.78	peak	
2	68.1512	9.14	11.73	20.87	40.00	-19.13	peak	
3	127.2176	9.70	13.44	23.14	43.50	-20.36	peak	
4	264.7456	10.93	13.12	24.05	46.00	-21.95	peak	
5	462.3455	9.63	17.68	27.31	46.00	-18.69	peak	
6 *	605.6592	8.17	20.32	28.49	46.00	-17.51	peak	

*:Maximum data x:Over limit !:over margin

Note: Measurement=Reading Level+Correc Factor. Factor=(LISN or ISN or PLC or Current Probe)Factor+Cable

Remark: All modes have been tested, and only worst data of GFSK (2402MHz) was listed in this report.

From 1G-25GHz

Test Mode: GFSK TX Low									
Freq (MHz)	Read Level (dBuV/m)	Polar (H/V)	Antenna Factor (dB/m)	Cable loss(dB)	Amp Factor (dB)	Result (dBuV/m)	Limit (dBuV/m)	Margin (dB)	Remark
4804	47.38	V	33.95	10.18	34.26	57.25	74	16.75	PK
4804	39.03	V	33.95	10.18	34.26	48.90	54	5.10	AV
7206	/	/	/	/	/	/	/	/	/
9608	/	/	/	/	/	/	/	/	/
4824	48.73	H	33.95	10.18	34.26	58.60	74	15.40	PK
4824	37.88	H	33.95	10.18	34.26	47.75	54	6.25	AV
7206	/	/	/	/	/	/	/	/	/
9608	/	/	/	/	/	/	/	/	/
Test Mode: GFSK TX Mid									
4882	45.78	V	33.93	10.2	34.29	55.62	74	18.38	PK
4882	35.95	V	33.93	10.2	34.29	45.79	54	8.21	AV
7323	/	/	/	/	/	/	/	/	/
9764	/	/	/	/	/	/	/	/	/
4882	47.13	H	33.93	10.2	34.29	56.97	74	17.03	PK
4882	35.56	H	33.93	10.2	34.29	45.40	54	8.60	AV
7323	/	/	/	/	/	/	/	/	/
9764	/	/	/	/	/	/	/	/	/
Test Mode: GFSK TX High									
4960	46.90	V	33.98	10.22	34.25	56.85	74	17.15	PK
4960	36.46	V	33.98	10.22	34.25	46.41	54	7.59	AV
7440	/	/	/	/	/	/	/	/	/
9920	/	/	/	/	/	/	/	/	/
4960	47.68	H	33.98	10.22	34.25	57.63	74	16.37	PK
4960	37.24	H	33.98	10.22	34.25	47.19	54	6.81	AV
7440	/	/	/	/	/	/	/	/	/
9920	/	/	/	/	/	/	/	/	/
Note:									
1, Result = Read level + Antenna factor + cable loss-Amp factor									
2, All the other emissions not reported were too low to read and deemed to comply with FCC limit.									

From 1G-25GHz

Test Mode: $\pi/4$ DQPSK TX Low									
Freq (MHz)	Read Level (dBuV/m)	Polar (H/V)	Antenna Factor (dB/m)	Cable loss(dB)	Amp Factor (dB)	Result (dBuV/m)	Limit (dBuV/m)	Margin (dB)	Remark
4804	48.37	V	33.95	10.18	34.26	58.24	74	15.76	PK
4804	38.86	V	33.95	10.18	34.26	48.73	54	5.27	AV
7206	/	/	/	/	/	/	/	/	/
9608	/	/	/	/	/	/	/	/	/
4824	50.15	H	33.95	10.18	34.26	60.02	74	13.98	PK
4824	37.78	H	33.95	10.18	34.26	47.65	54	6.35	AV
7206	/	/	/	/	/	/	/	/	/
9608	/	/	/	/	/	/	/	/	/
Test Mode: $\pi/4$ DQPSK TX Mid									
4882	47.41	V	33.93	10.2	34.29	57.25	74	16.75	PK
4882	36.21	V	33.93	10.2	34.29	46.05	54	7.95	AV
7323	/	/	/	/	/	/	/	/	/
9764	/	/	/	/	/	/	/	/	/
4882	45.74	H	33.93	10.2	34.29	55.58	74	18.42	PK
4882	35.47	H	33.93	10.2	34.29	45.31	54	8.69	AV
7323	/	/	/	/	/	/	/	/	/
9764	/	/	/	/	/	/	/	/	/
Test Mode: $\pi/4$ DQPSK TX High									
4960	46.12	V	33.98	10.22	34.25	56.07	74	17.93	PK
4960	37.27	V	33.98	10.22	34.25	47.22	54	6.78	AV
7440	/	/	/	/	/	/	/	/	/
9920	/	/	/	/	/	/	/	/	/
4960	47.86	H	33.98	10.22	34.25	57.81	74	16.19	PK
4960	36.04	H	33.98	10.22	34.25	45.99	54	8.01	AV
7440	/	/	/	/	/	/	/	/	/
9920	/	/	/	/	/	/	/	/	/
Note:									
1, Result = Read level + Antenna factor + cable loss-Amp factor									
2, All the other emissions not reported were too low to read and deemed to comply with FCC limit.									

From 1G-25GHz

Test Mode: 8- DQPSK TX Low									
Freq (MHz)	Read Level (dBuV/m)	Polar (H/V)	Antenna Factor (dB/m)	Cable loss(dB)	Amp Factor (dB)	Result (dBuV/m)	Limit (dBuV/m)	Margin (dB)	Remark
4804	44.53	V	33.95	10.18	34.26	54.40	74	19.60	PK
4804	34.84	V	33.95	10.18	34.26	44.71	54	9.29	AV
7206	/	/	/	/	/	/	/	/	/
9608	/	/	/	/	/	/	/	/	/
4824	42.67	H	33.95	10.18	34.26	52.54	74	21.46	PK
4824	35.14	H	33.95	10.18	34.26	45.01	54	8.99	AV
7206	/	/	/	/	/	/	/	/	/
9608	/	/	/	/	/	/	/	/	/
Test Mode: 8- DQPSK TX Mid									
4882	42.17	V	33.93	10.2	34.29	52.01	74	21.99	PK
4882	34.59	V	33.93	10.2	34.29	44.43	54	9.57	AV
7323	/	/	/	/	/	/	/	/	/
9764	/	/	/	/	/	/	/	/	/
4882	45.06	H	33.93	10.2	34.29	54.90	74	19.10	PK
4882	35.31	H	33.93	10.2	34.29	45.15	54	8.85	AV
7323	/	/	/	/	/	/	/	/	/
9764	/	/	/	/	/	/	/	/	/
Test Mode: 8- DQPSK TX High									
4960	45.62	V	33.98	10.22	34.25	55.57	74	18.43	PK
4960	34.05	V	33.98	10.22	34.25	44.00	54	10.00	AV
7440	/	/	/	/	/	/	/	/	/
9920	/	/	/	/	/	/	/	/	/
4960	45.35	H	33.98	10.22	34.25	55.30	74	18.70	PK
4960	34.30	H	33.98	10.22	34.25	44.25	54	9.75	AV
7440	/	/	/	/	/	/	/	/	/
9920	/	/	/	/	/	/	/	/	/
Note:									
1, Result = Read level + Antenna factor + cable loss-Amp factor									
2, All the other emissions not reported were too low to read and deemed to comply with FCC limit.									

9. BAND EDGE COMPLIANCE

9.1. Block Diagram of Test Setup

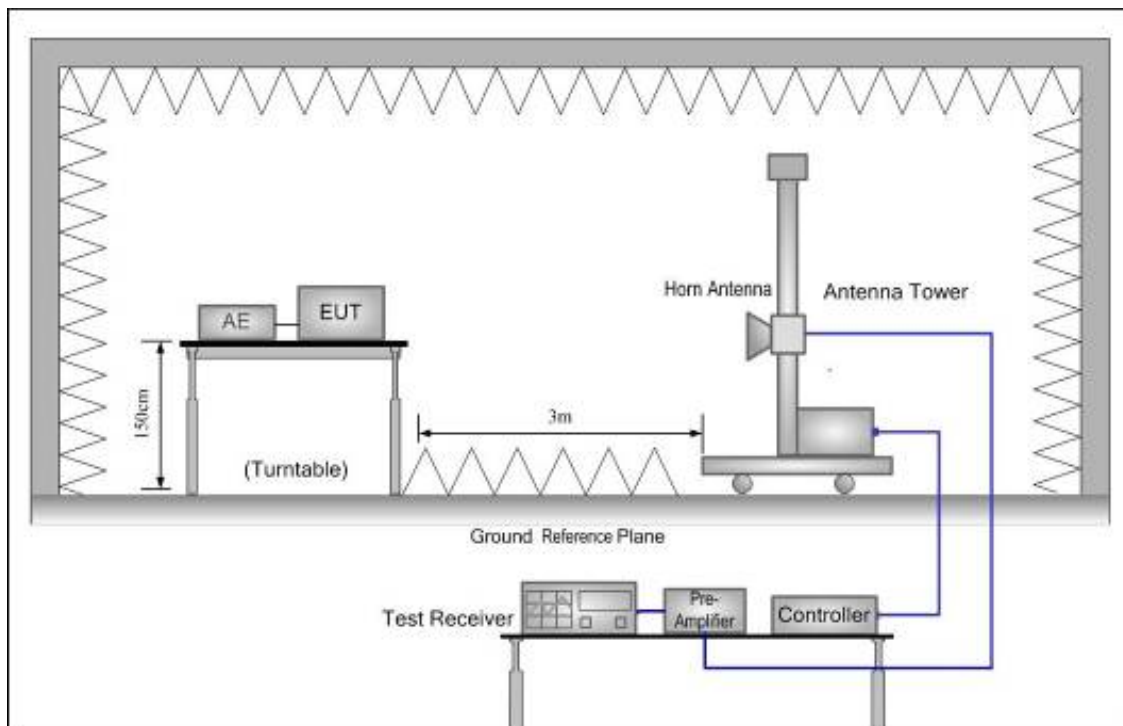

9.2. Limit

All the lower and upper band-edges emissions appearing within restricted frequency bands shall not exceed the limits shown in 15.209, all the other emissions outside operation shall be at least 20dB below the fundamental emissions, or comply with 15.209 limits.

9.3. Test Procedure

All restriction band and non- restriction band have been tested, only worse case is reported.

9.4. Test Result

PASS. (See below detailed test data)

Radiated Method:

Hopping-off

Polarization: Vertical

Test Mode:

GFSK-Low

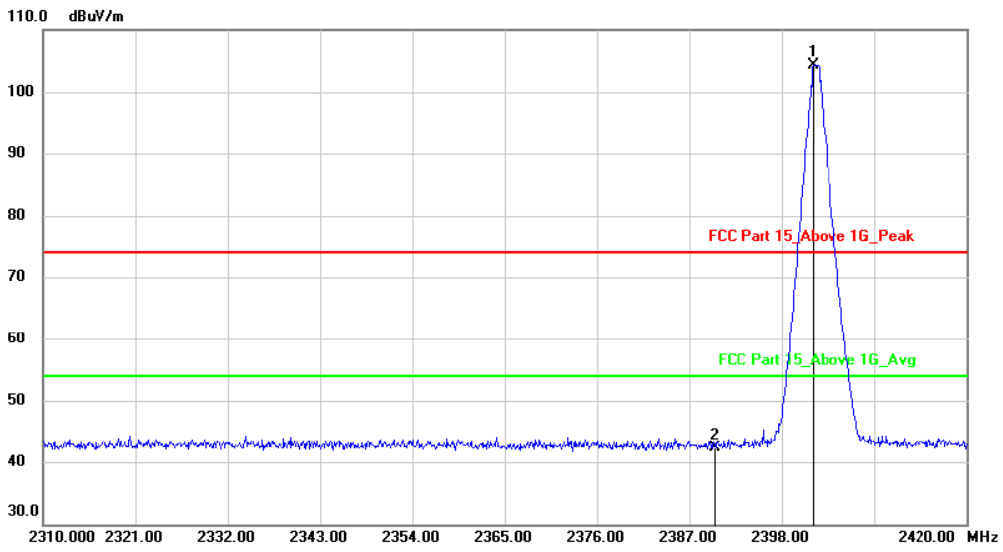

No.	Mk.	Freq. MHz	Reading Level dBuV	Correct Factor dB	Measure- ment dBuV/m	Limit dBuV/m	Margin dB	Detector	Antenna Height cm	Table Degree degree	Comment
1	*	2401.740	120.03	-15.78	104.25	74.00	30.25	peak			
2		2390.000	58.14	-15.77	42.37	74.00	-31.63	peak			

Polarization: Horizontal

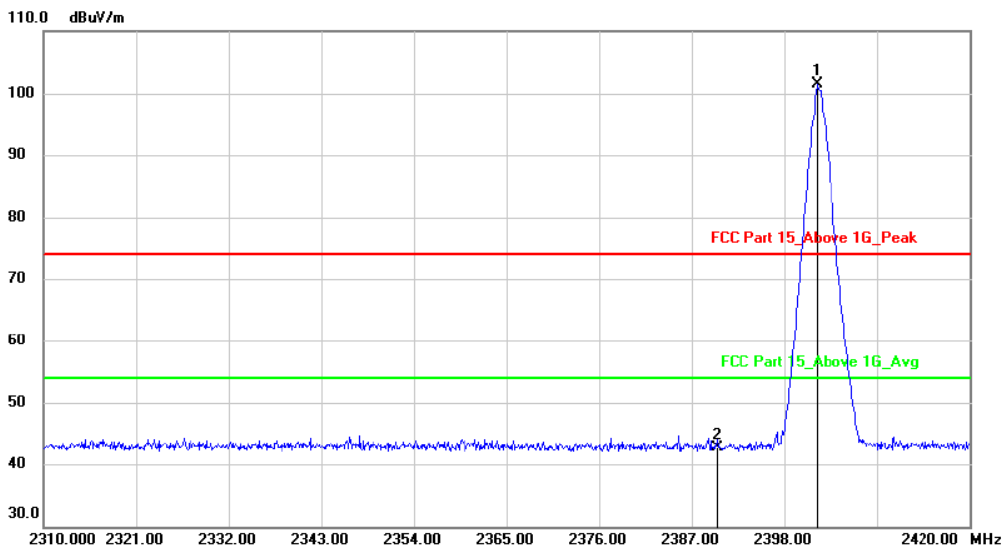

No.	Mk.	Freq. MHz	Reading Level dBuV	Correct Factor dB	Measure- ment dBuV/m	Limit dBuV/m	Margin dB	Detector	Antenna Height cm	Table Degree degree	Comment
1	*	2401.850	117.30	-15.78	101.52	74.00	27.52	peak			
2		2390.000	58.53	-15.77	42.76	74.00	-31.24	peak			

Hopping-on

Polarization: Vertical

Test Mode: GFSK-Low

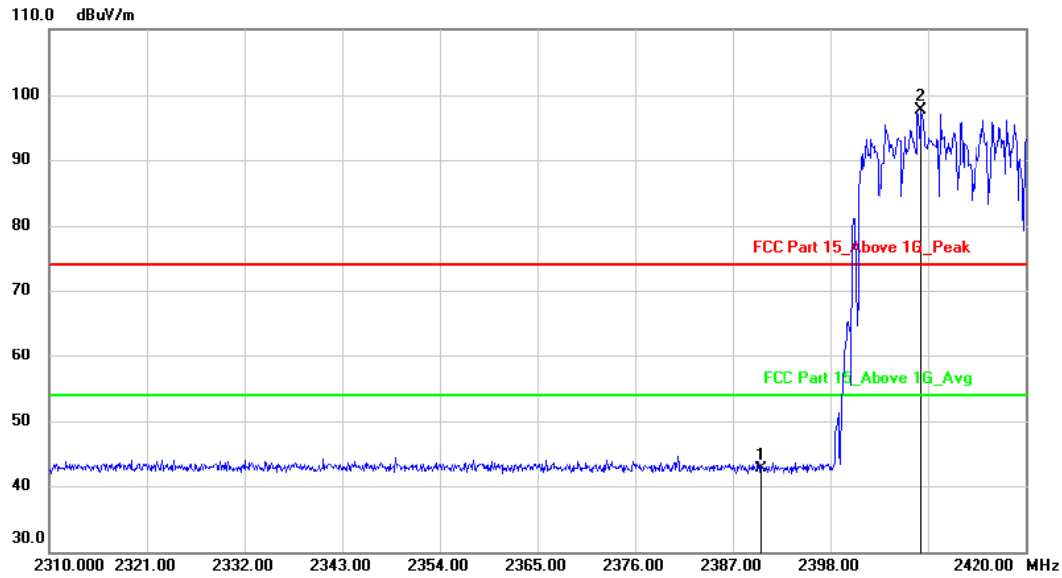

No.	Mk.	Freq.	Reading Level	Correct Factor	Measurement	Limit	Margin	Antenna Height	Table Degree	
		MHz	dBuV	dB	dBuV/m	dBuV/m	dB	cm	degree	Comment
1		2390.000	58.55	-15.77	42.78	74.00	-31.22			peak
2	*	2408.230	113.41	-15.77	97.64	74.00	23.64			peak

Polarization: Horizontal

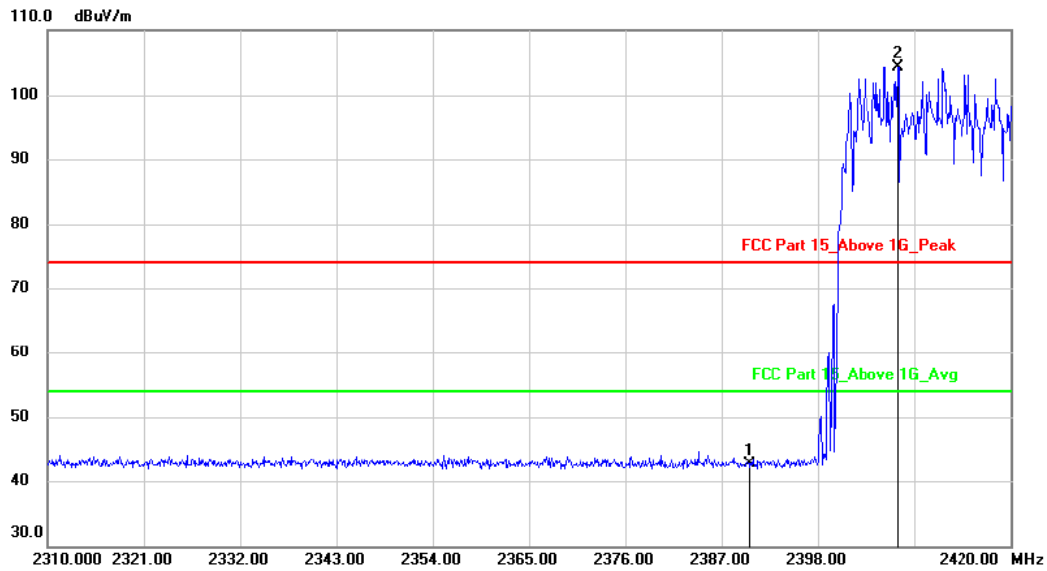

No.	Mk.	Freq.	Reading Level	Correct Factor	Measurement	Limit	Margin	Antenna Height	Table Degree	
		MHz	dBuV	dB	dBuV/m	dBuV/m	dB	cm	degree	Comment
1		2390.000	58.55	-15.77	42.78	74.00	-31.22			peak
2	*	2407.130	120.02	-15.77	104.25	74.00	30.25			peak

Hopping-off

Polarization: Vertical

Test Mode: GFSK-High

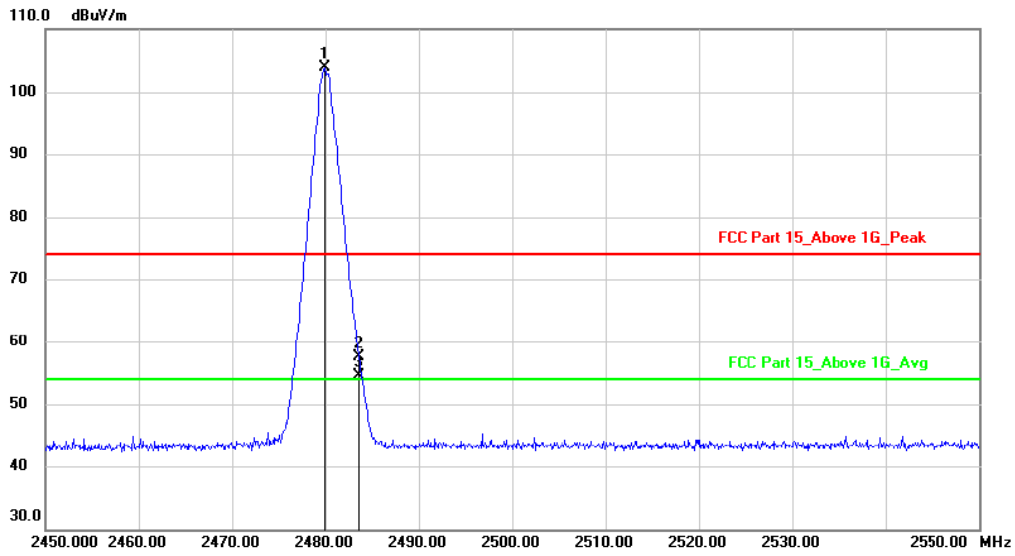

No.	Mk.	Freq.	Reading Level	Correct Factor	Measurement	Limit	Margin	Antenna Height	Table Degree	
		MHz	dBuV	dB	dBuV/m	dBuV/m	dB	cm	degree	Comment
1	*	2479.900	119.56	-15.69	103.87	74.00	29.87			peak
2		2483.500	73.28	-15.68	57.60	74.00	-16.40			peak
3	X	2483.500	70.22	-15.68	54.54	54.00	0.54			AVG

Polarization: Horizontal

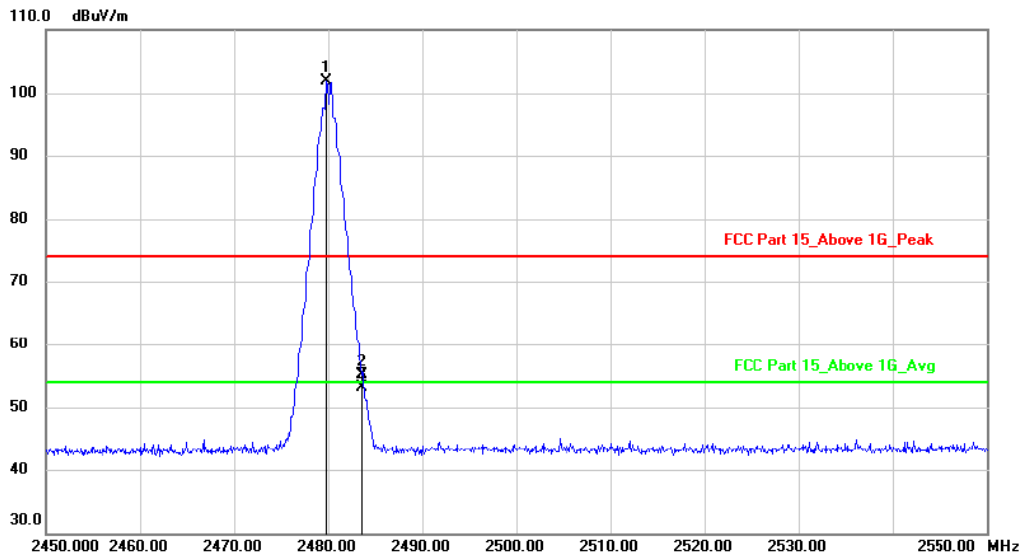

No.	Mk.	Freq.	Reading Level	Correct Factor	Measurement	Limit	Margin	Antenna Height	Table Degree	
		MHz	dBuV	dB	dBuV/m	dBuV/m	dB	cm	degree	Comment
1	*	2479.800	117.66	-15.69	101.97	74.00	27.97			peak
2		2483.500	70.79	-15.68	55.11	74.00	-18.89			peak
3		2483.500	68.84	-15.68	53.16	54.00	-0.84			AVG

Hopping-on

Polarization: Vertical

Test Mode: GFSK-High

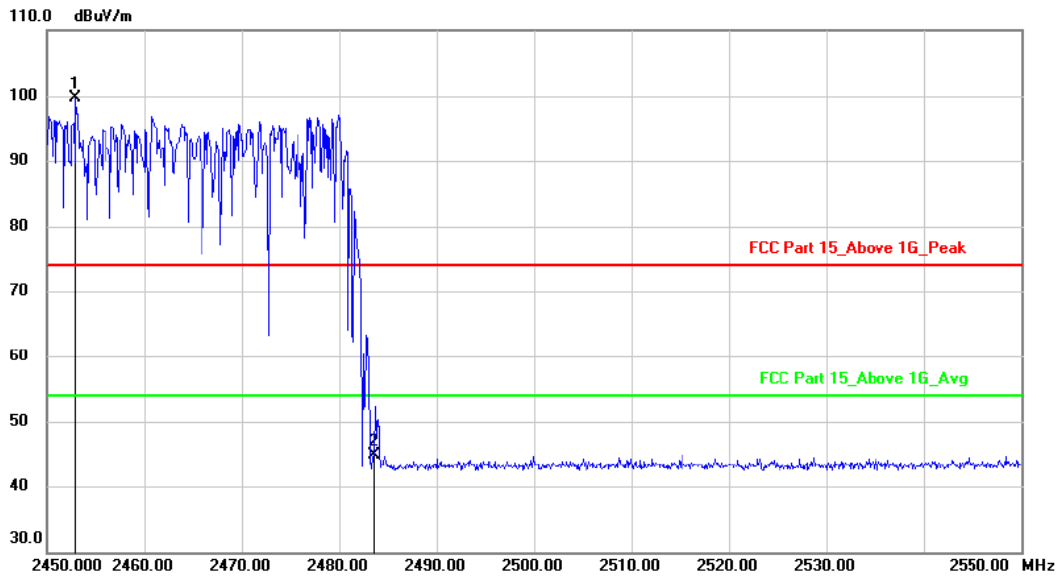

No.	Mk.	Freq.	Reading Level	Correct Factor	Measurement	Limit	Margin	Antenna Height	Table Degree
		MHz	dBuV	dB	dBuV/m	dBuV/m	dB	cm	degree
1	*	2452.900	115.52	-15.72	99.80	74.00	25.80	peak	
2		2483.500	60.51	-15.68	44.83	74.00	-29.17	peak	

Polarization: Horizontal

Test Mode: GFSK-High

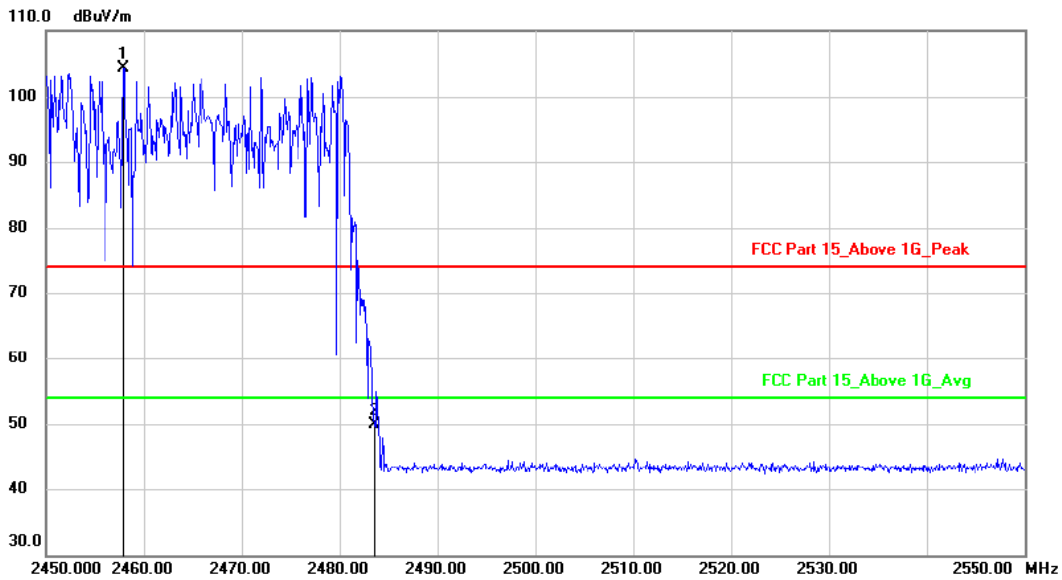

No.	Mk.	Freq.	Reading Level	Correct Factor	Measurement	Limit	Margin	Antenna Height	Table Degree
		MHz	dBuV	dB	dBuV/m	dBuV/m	dB	cm	degree
1	*	2457.900	120.00	-15.71	104.29	74.00	30.29	peak	
2		2483.500	65.66	-15.68	49.98	74.00	-24.02	peak	

hopping-on

Hopping-off

Polarization: Vertical

Test Mode: $\pi/4$ DQPSK -Low

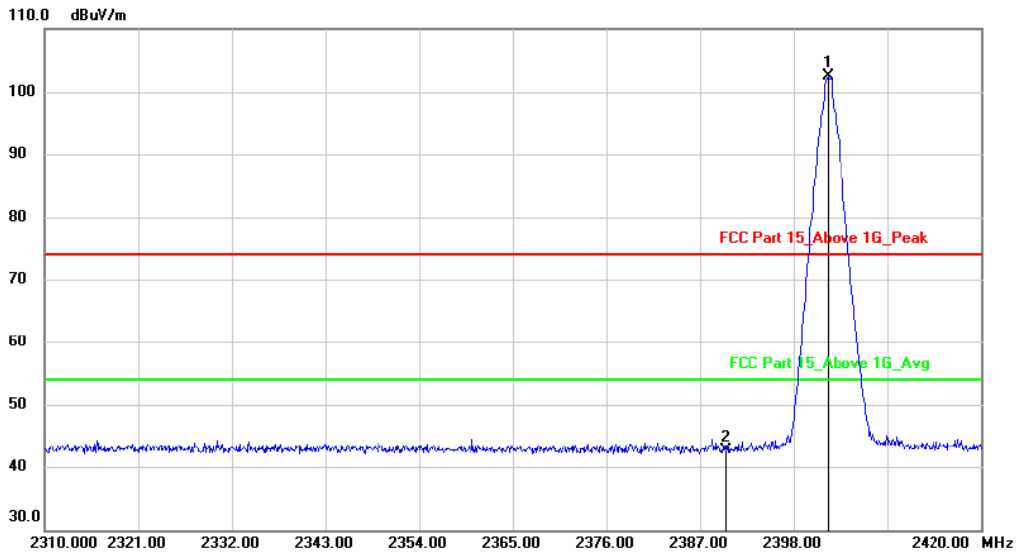

No.	Mk.	Freq. MHz	Reading Level dBuV	Correct Factor dB	Measure- ment dBuV/m	Limit dBuV/m	Margin dB	Detector	Antenna Height cm	Table Degree	Comment
1	*	2401.960	118.28	-15.78	102.50	74.00	28.50	peak			
2		2390.000	58.53	-15.77	42.76	74.00	-31.24	peak			

Polarization: Horizontal

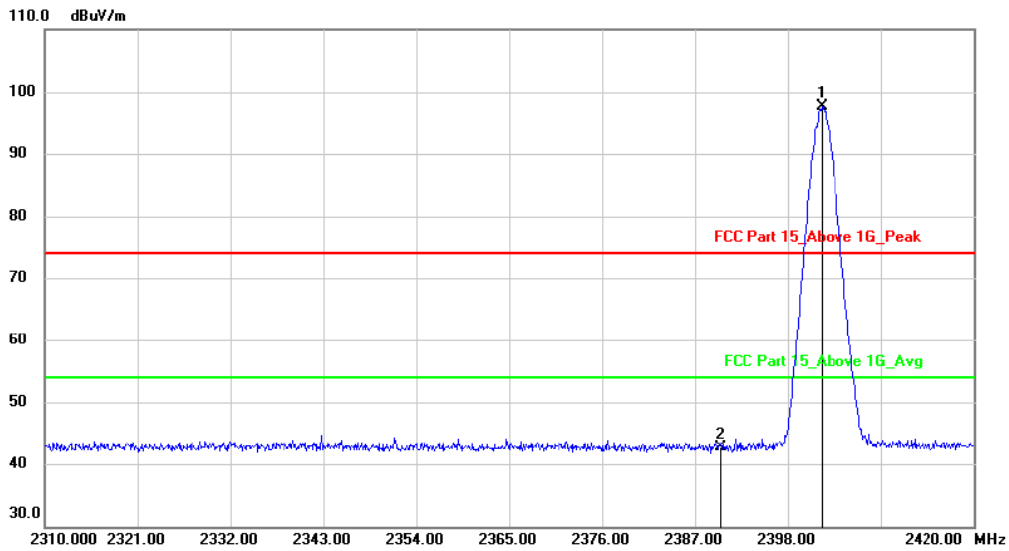

No.	Mk.	Freq. MHz	Reading Level dBuV	Correct Factor dB	Measure- ment dBuV/m	Limit dBuV/m	Margin dB	Detector	Antenna Height cm	Table Degree	Comment
1	*	2401.960	113.54	-15.78	97.76	74.00	23.76	peak			
2		2390.000	58.54	-15.77	42.77	74.00	-31.23	peak			

Hopping-on

Polarization: Vertical

Test Mode: $\pi/4$ DQPSK -Low

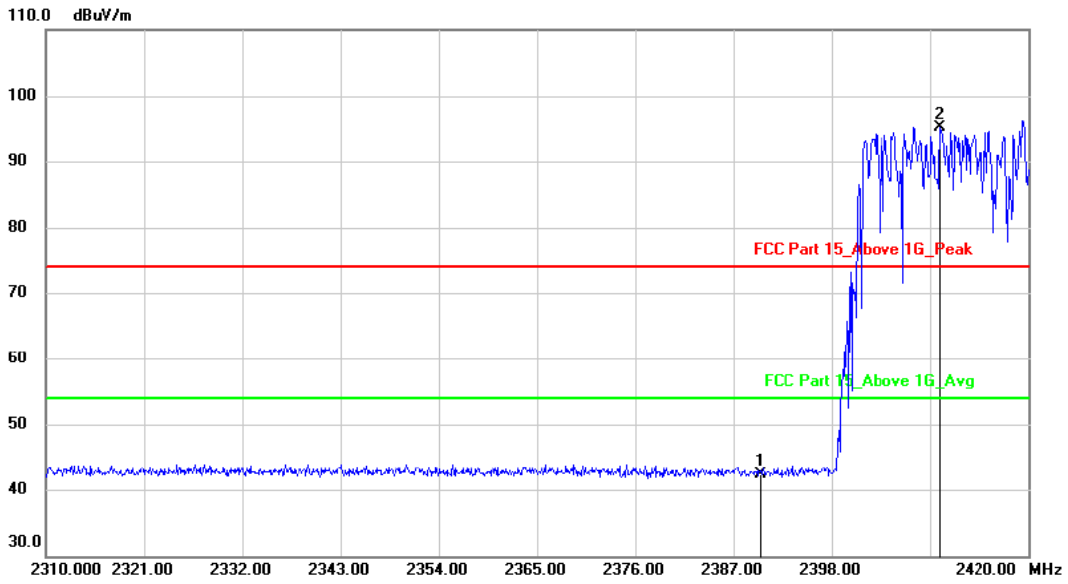

No.	Mk.	Freq. MHz	Reading Level dBuV	Correct Factor dB	Measure- ment dBuV/m	Limit dBuV/m	Margin dB	Antenna Height cm	Table Degree	Detector	Comment
1		2390.000	58.01	-15.77	42.24	74.00	-31.76			peak	
2	*	2410.100	110.95	-15.76	95.19	74.00	21.19			peak	

Polarization: Horizontal

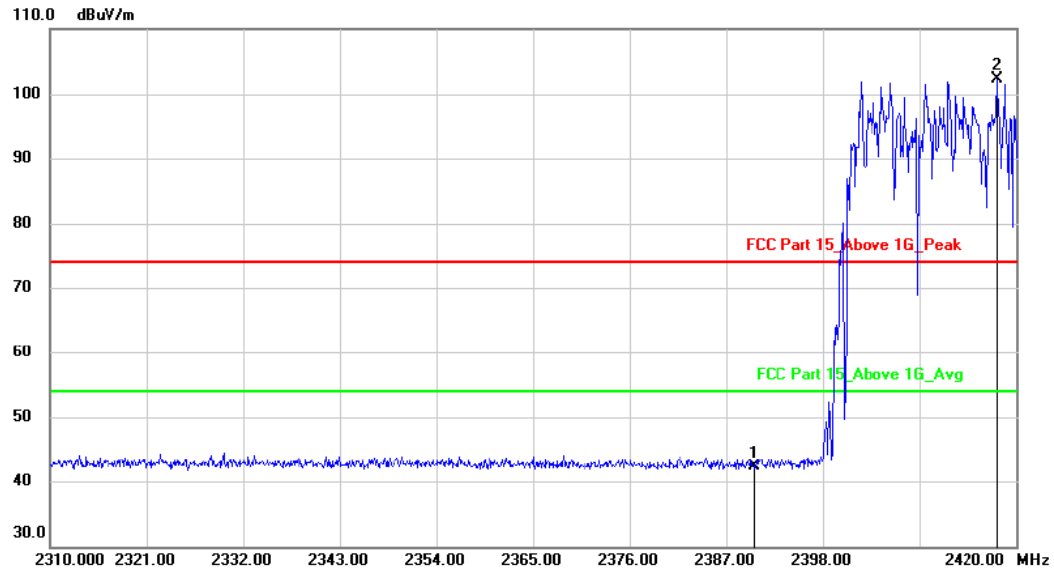

No.	Mk.	Freq. MHz	Reading Level dBuV	Correct Factor dB	Measure- ment dBuV/m	Limit dBuV/m	Margin dB	Antenna Height cm	Table Degree	Detector	Comment
1		2390.000	58.12	-15.77	42.35	74.00	-31.65			peak	
2	*	2417.800	118.09	-15.76	102.33	74.00	28.33			peak	

Hopping-off

Polarization: Vertical

Test Mode: $\pi/4$ DQPSK -High

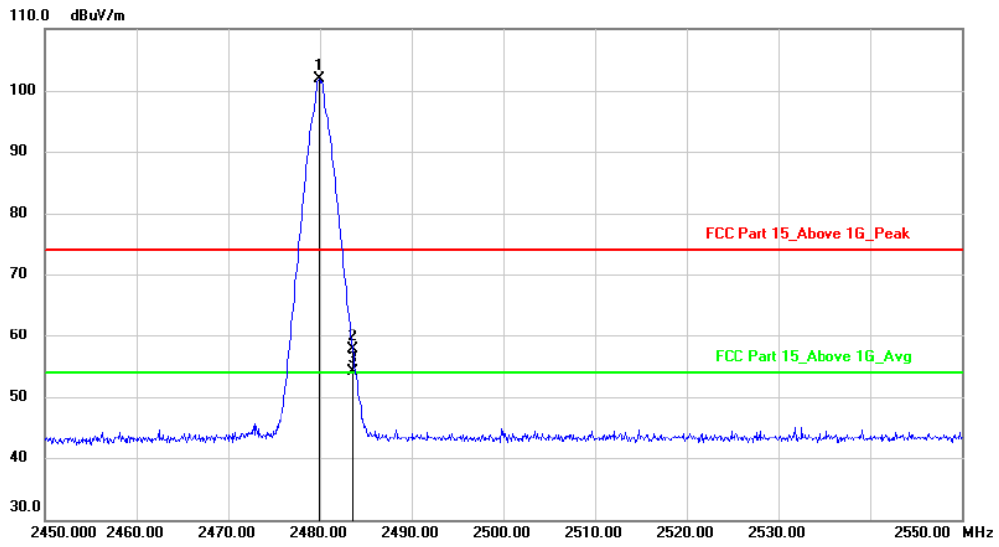

No.	Mk.	Freq.	Reading Level	Correct Factor	Measurement	Limit	Margin	Antenna Height	Table Degree	
		MHz	dBuV	dB	dBuV/m	dBuV/m	dB	cm	degree	Comment
1	*	2479.900	117.58	-15.69	101.89	74.00	27.89			peak
2		2483.500	73.32	-15.68	57.64	74.00	-16.36			peak
3	X	2483.500	69.76	-15.68	54.08	54.00	0.08			AVG

Polarization: Horizontal

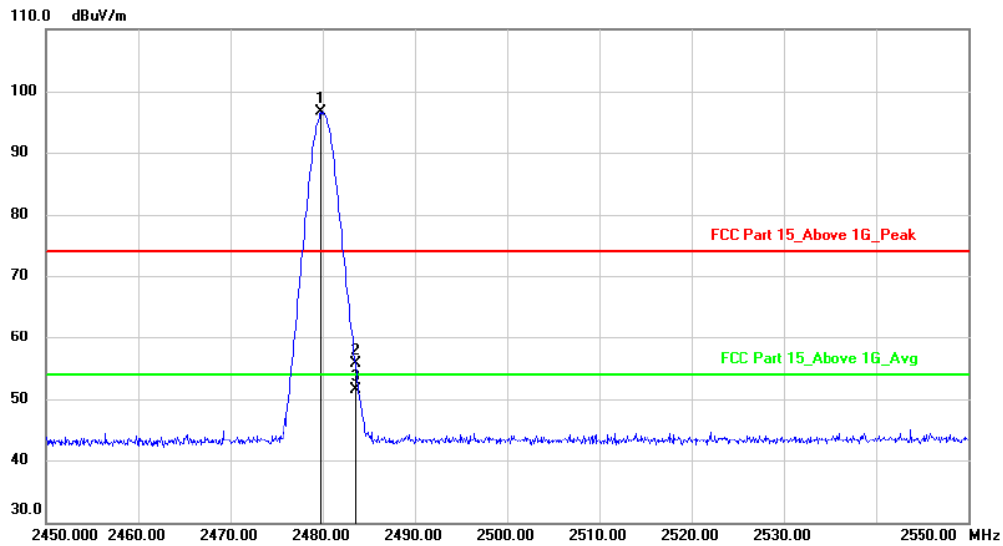

No.	Mk.	Freq.	Reading Level	Correct Factor	Measurement	Limit	Margin	Antenna Height	Table Degree	
		MHz	dBuV	dB	dBuV/m	dBuV/m	dB	cm	degree	Comment
1	*	2479.800	112.39	-15.69	96.70	74.00	22.70			peak
2		2483.500	71.35	-15.68	55.67	74.00	-18.33			peak
3		2483.500	67.14	-15.68	51.46	54.00	-2.54			AVG

Hopping-on

Polarization: Vertical

Test Mode: π /4 DQPSK -High

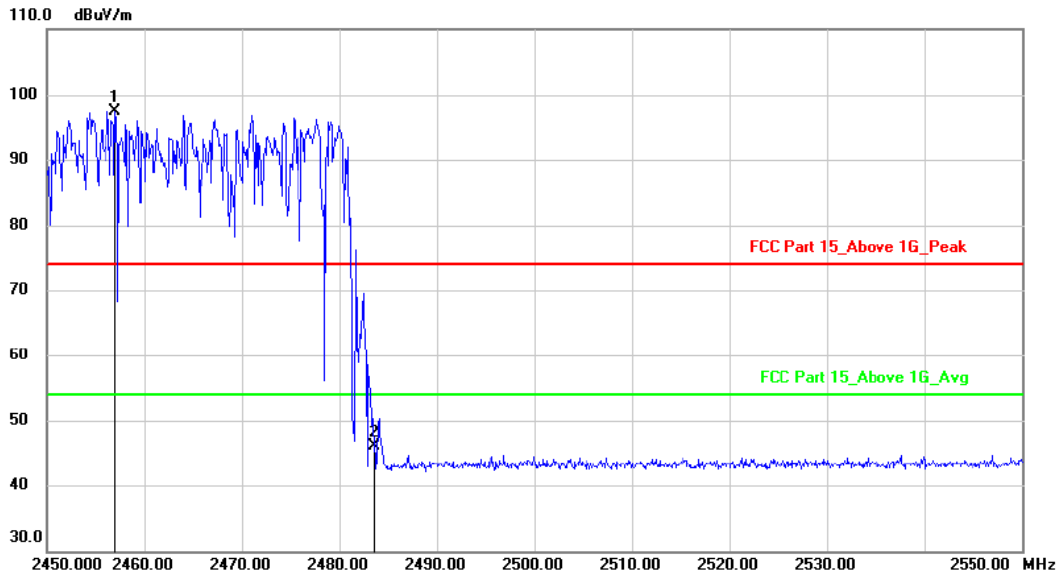

No.	Mk.	Freq.	Reading Level	Correct Factor	Measurement	Limit	Margin	Antenna Height	Table Degree	
		MHz	dBuV	dB	dBuV/m	dBuV/m	dB	cm	degree	Comment
1	*	2457.000	113.30	-15.71	97.59	74.00	23.59			peak
2		2483.500	61.75	-15.68	46.07	74.00	-27.93			peak

Polarization: Horizontal

Test Mode: GFSK-High

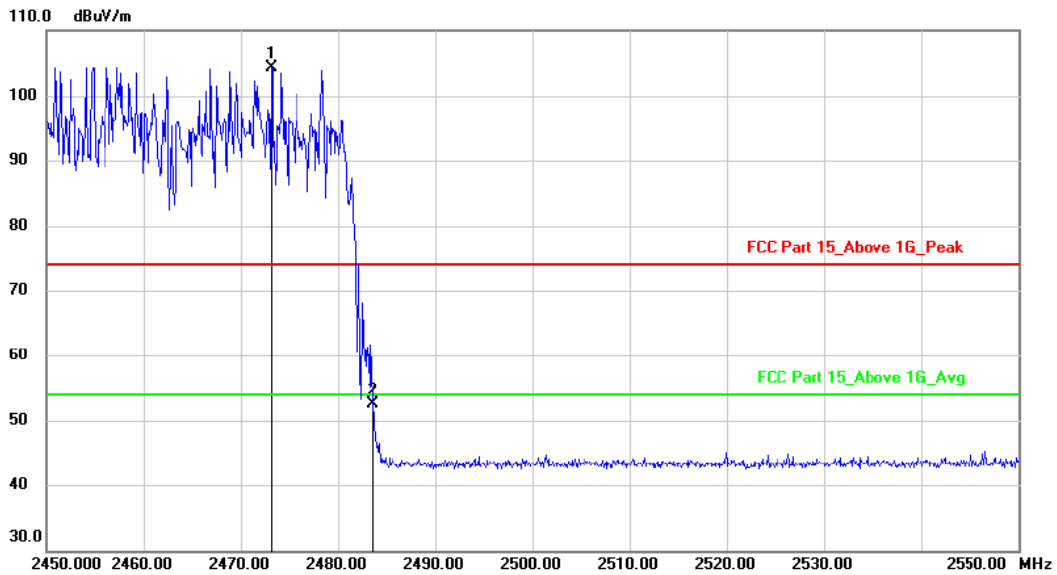

No.	Mk.	Freq.	Reading Level	Correct Factor	Measurement	Limit	Margin	Antenna Height	Table Degree	
		MHz	dBuV	dB	dBuV/m	dBuV/m	dB	cm	degree	Comment
1	*	2473.100	120.01	-15.70	104.31	74.00	30.31			peak
2		2483.500	68.16	-15.68	52.48	74.00	-21.52			peak

hopping-on

Hopping-off

Polarization: Vertical

Test Mode: 8DPSK-Low

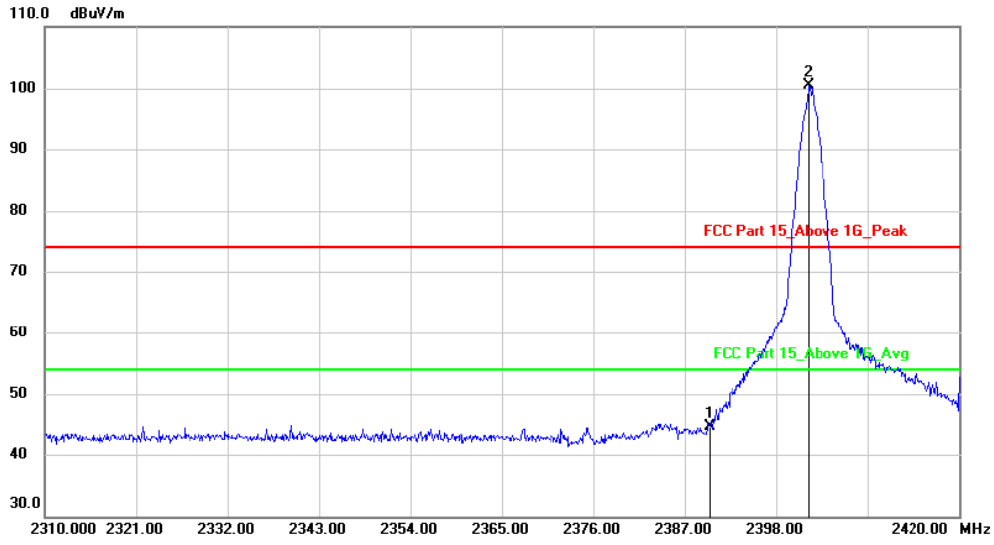

No. Mk.	Freq. MHz	Reading Level dBuV	Correct Factor dB	Measurement dBuV/m	Limit dBuV/m	Margin dB	Detector	Antenna Height cm	Table Degree	Comment
1	2390.000	60.56	-15.77	44.79	74.00	-29.21	peak			
2 *	2401.850	116.30	-15.78	100.52	74.00	26.52	peak			

Polarization: Horizontal

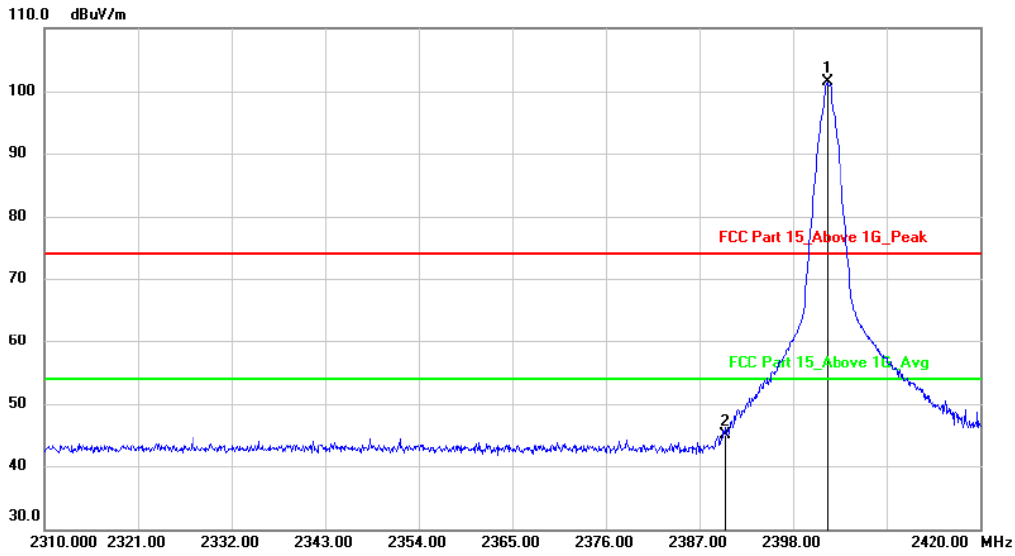

No. Mk.	Freq. MHz	Reading Level dBuV	Correct Factor dB	Measurement dBuV/m	Limit dBuV/m	Margin dB	Detector	Antenna Height cm	Table Degree	Comment
1 *	2401.960	117.19	-15.78	101.41	74.00	27.41	peak			
2	2390.000	60.83	-15.77	45.06	74.00	-28.94	peak			

Hopping-on

Polarization: Vertical

Test Mode: 8DPSK-Low

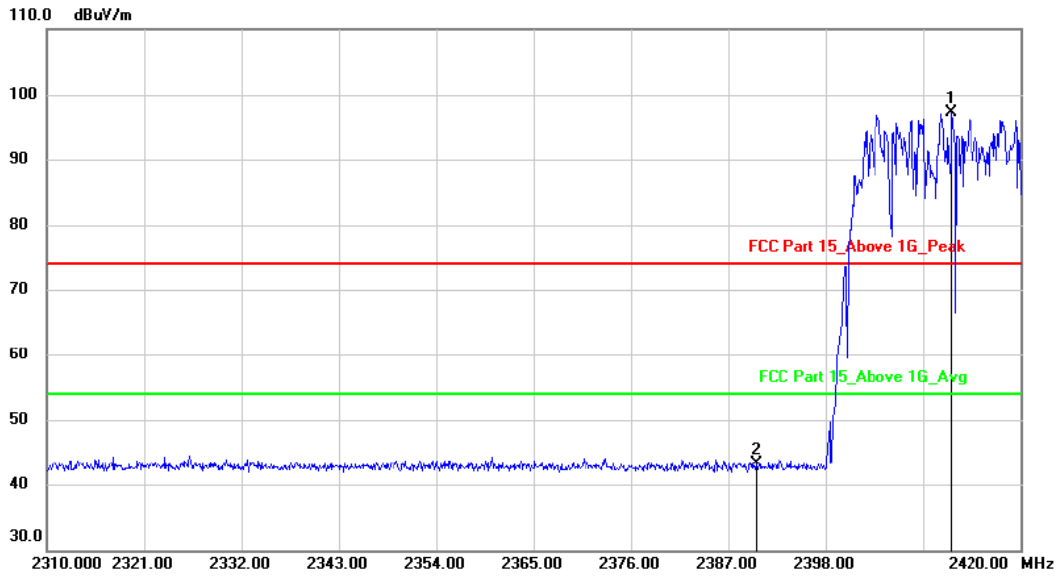

No.	Mk.	Freq. MHz	Reading Level dBuV	Correct Factor dB	Measure- ment dBuV/m	Limit dBuV/m	Margin dB	Antenna Height cm	Table Degree	Comment
1	*	2412.190	113.15	-15.76	97.39	74.00	23.39	peak		
2		2390.000	59.03	-15.77	43.26	74.00	-30.74	peak		

Polarization: Horizontal

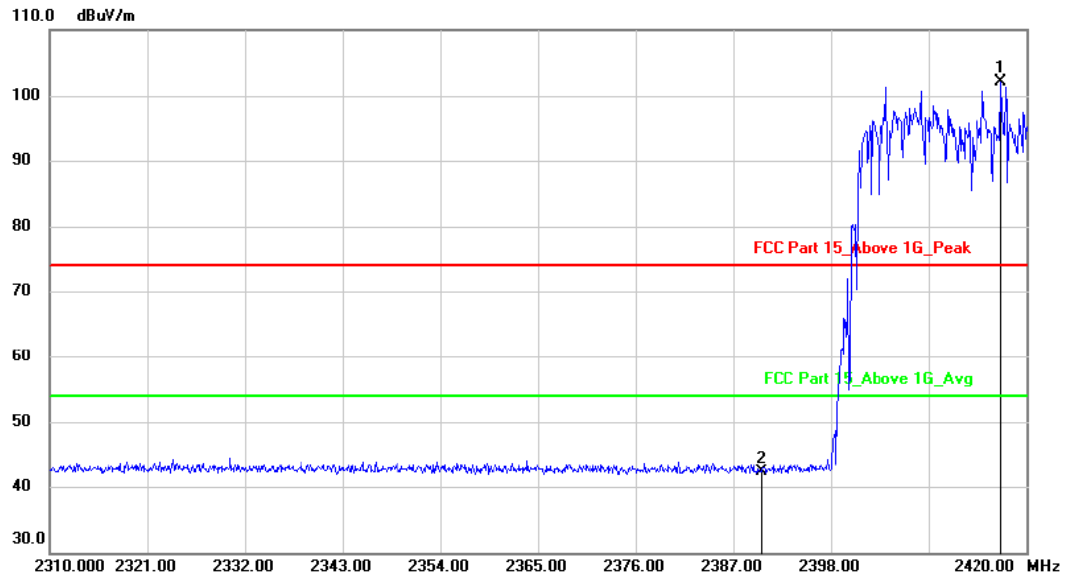

No.	Mk.	Freq. MHz	Reading Level dBuV	Correct Factor dB	Measure- ment dBuV/m	Limit dBuV/m	Margin dB	Antenna Height cm	Table Degree	Comment
1	*	2417.140	117.92	-15.76	102.16	74.00	28.16	peak		
2		2390.000	58.07	-15.77	42.30	74.00	-31.70	peak		

Hopping-off

Polarization: Vertical

Test Mode: 8DPSK-High

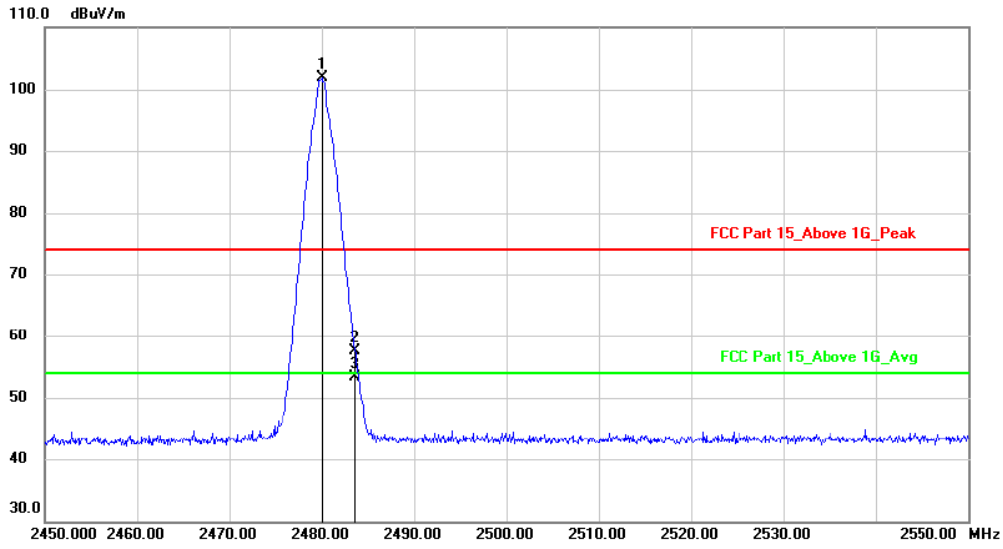

No. Mk.	Freq.	Reading Level	Correct Factor	Measurement	Limit	Margin	Antenna Height	Table Degree
	MHz	dBuV	dB	dBuV/m	dBuV/m	dB	cm	degree
1 *	2480.000	117.57	-15.69	101.88	74.00	27.88		peak
2	2483.500	73.25	-15.68	57.57	74.00	-16.43		peak
3	2483.500	69.01	-15.68	53.33	54.00	-0.67		AVG

Polarization: Horizontal

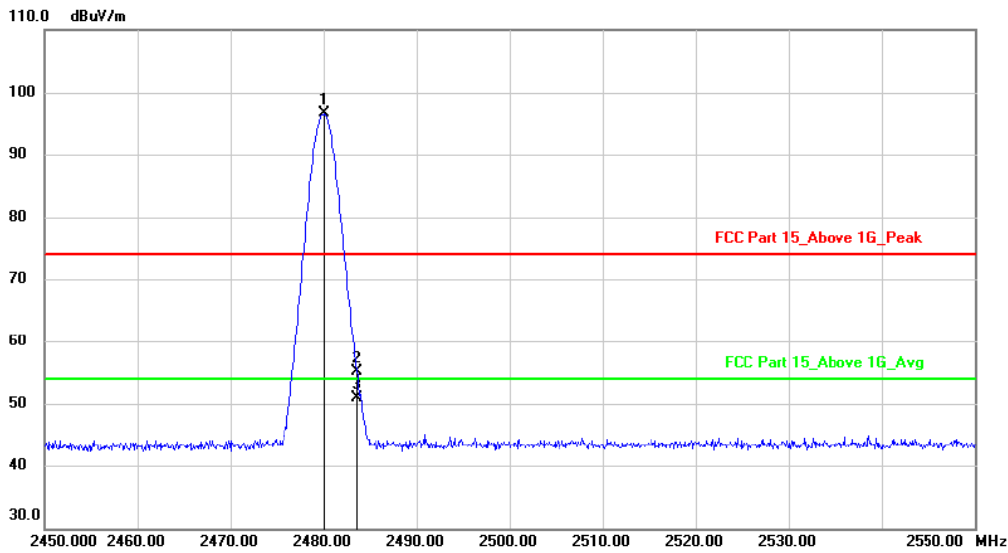

No. Mk.	Freq.	Reading Level	Correct Factor	Measurement	Limit	Margin	Antenna Height	Table Degree
	MHz	dBuV	dB	dBuV/m	dBuV/m	dB	cm	degree
1 *	2480.000	112.35	-15.69	96.66	74.00	22.66		peak
2	2483.500	70.84	-15.68	55.16	74.00	-18.84		peak
3	2483.500	66.50	-15.68	50.82	54.00	-3.18		AVG

Hopping-on

Polarization: Vertical

Test Mode: 8DPSK-High

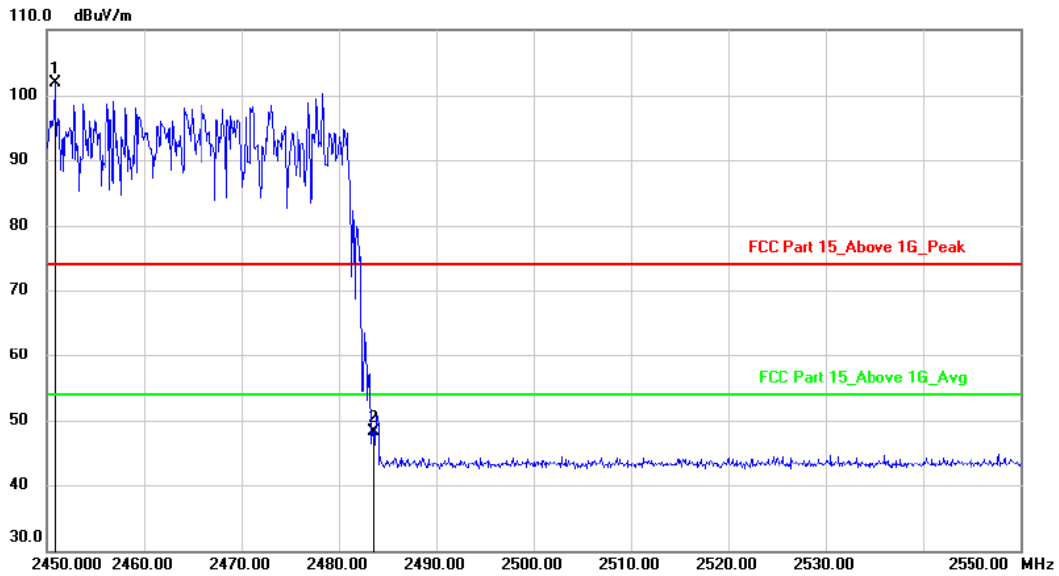

No.	Mk.	Freq.	Reading Level	Correct Factor	Measurement	Limit	Margin	Antenna Height	Table Degree	
		MHz	dBuV	dB	dBuV/m	dBuV/m	dB	cm	degree	Comment
1	*	2450.800	117.70	-15.72	101.98	74.00	27.98			peak
2		2483.500	63.93	-15.68	48.25	74.00	-25.75			peak

Polarization: Horizontal

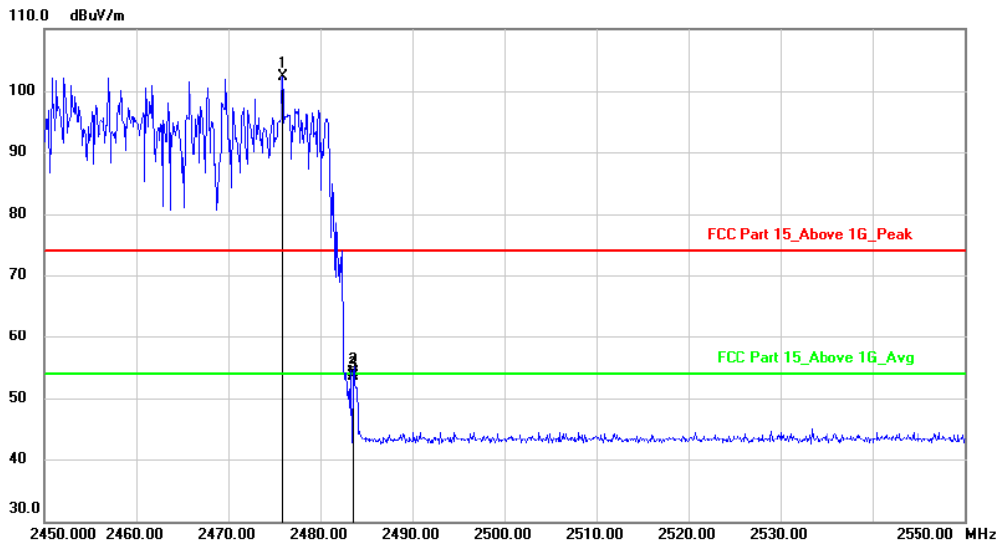

No.	Mk.	Freq.	Reading Level	Correct Factor	Measurement	Limit	Margin	Antenna Height	Table Degree	
		MHz	dBuV	dB	dBuV/m	dBuV/m	dB	cm	degree	Comment
1	*	2475.900	118.09	-15.70	102.39	74.00	28.39			peak
2		2483.500	69.81	-15.68	54.13	74.00	-19.87			peak
3		2483.500	69.24	-15.68	53.56	54.00	-0.44			AVG

Conducted Method

Band Edge NVNT 1-DH1 2402MHz Ant1 Hopping Emission

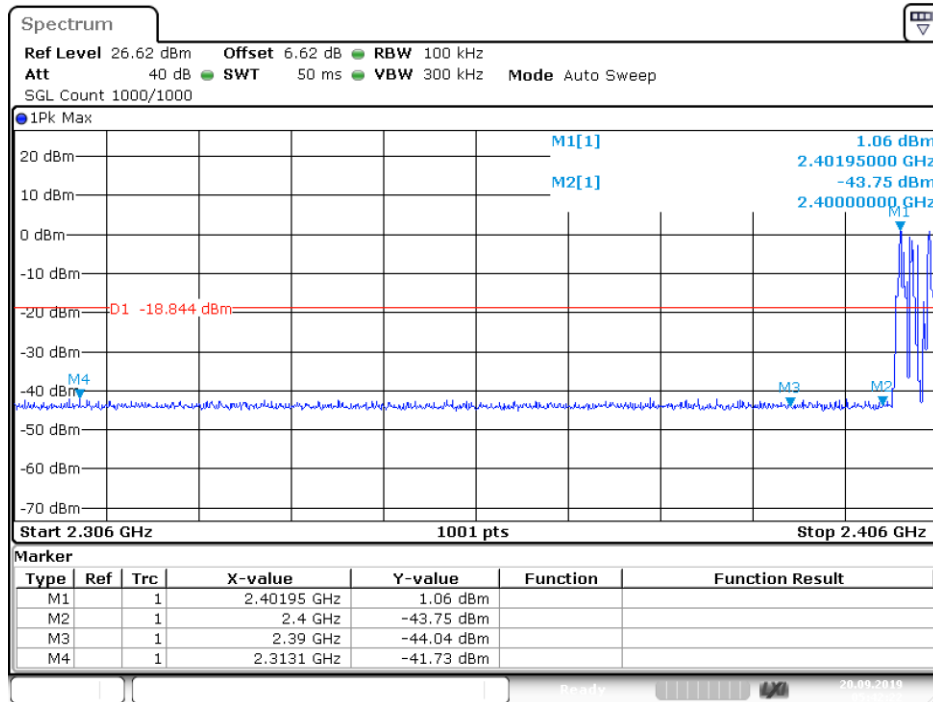

Date: 22.AUG.2019 05:42:22

Band Edge NVNT 1-DH1 2402MHz Ant1 No-Hopping Emission

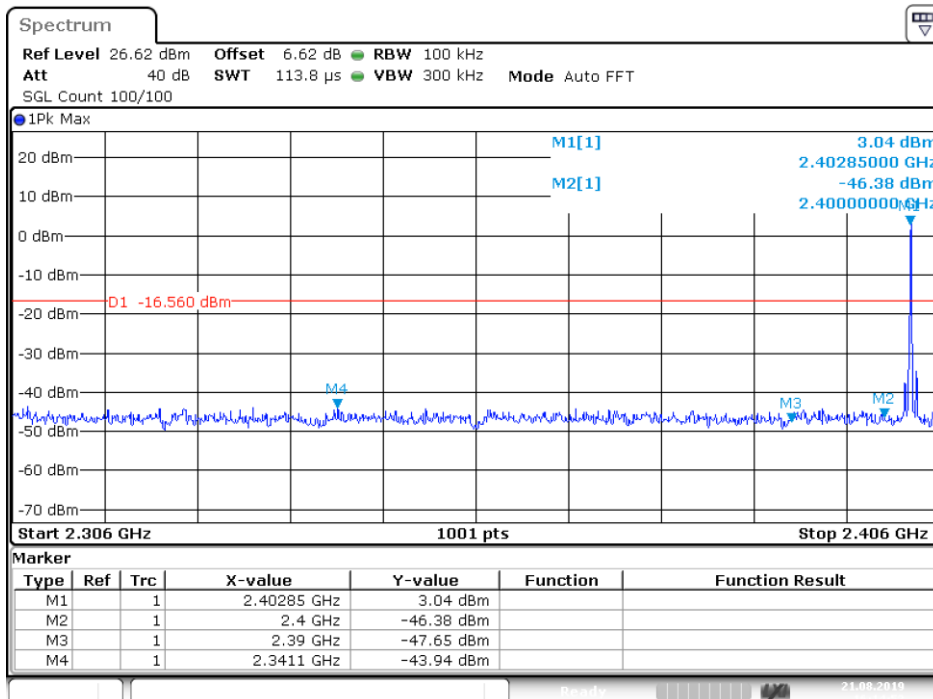

Date: 21.AUG.2019 16:14:52

Band Edge NVNT 1-DH1 2480MHz Ant1 Hopping Emission

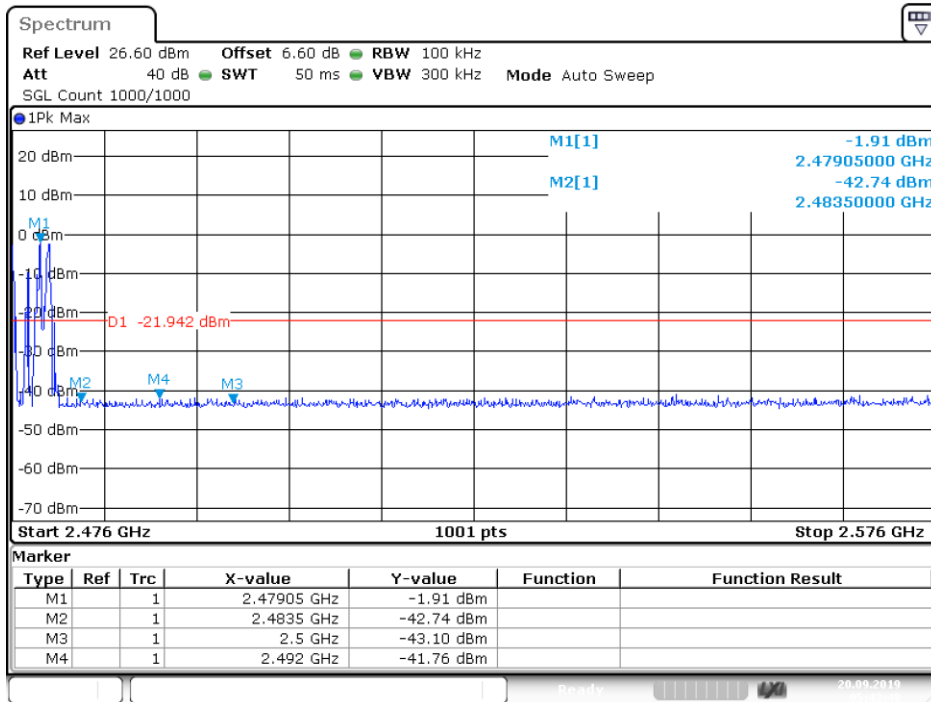

Band Edge NVNT 1-DH1 2480MHz Ant1 No-Hopping Emission

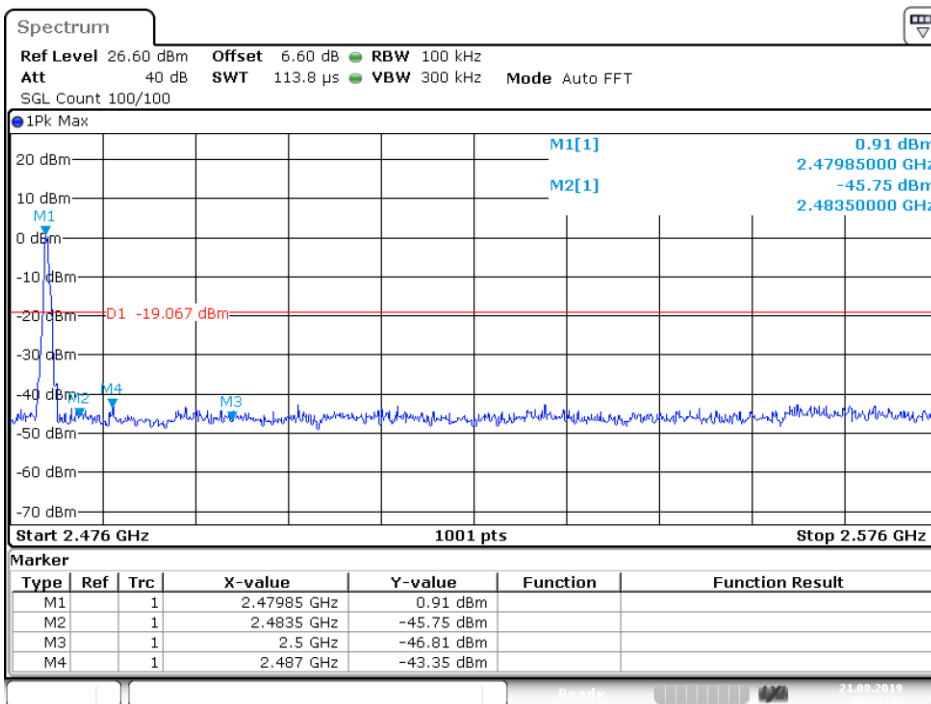

Band Edge NVLT 2-DH1 2402MHz Ant1 Hopping Emission

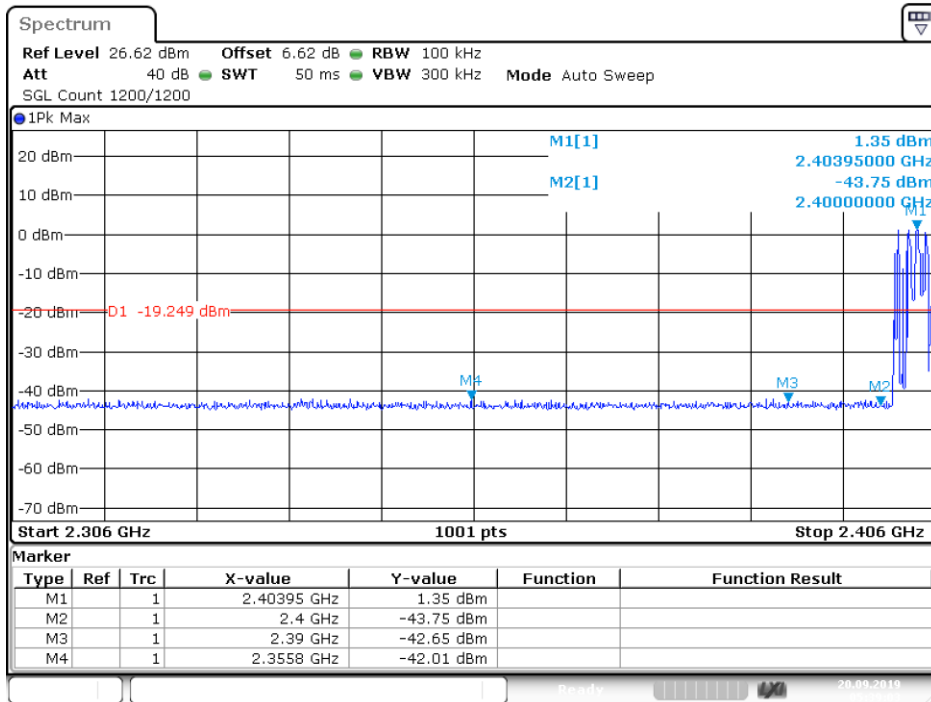

Date: 22.AUG.2019 05:39:03

Band Edge NVNT 2-DH1 2402MHz Ant1 No-Hopping Emission

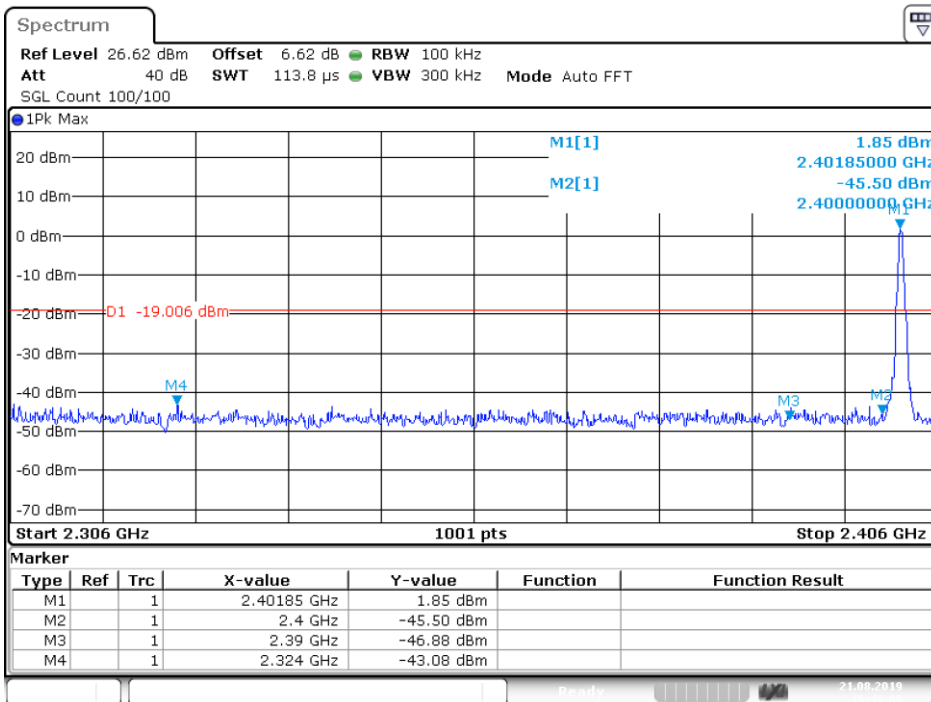

Date: 21.AUG.2019 16:48:09

Band Edge NVLT 2-DH1 2480MHz Ant1 Hopping Emission

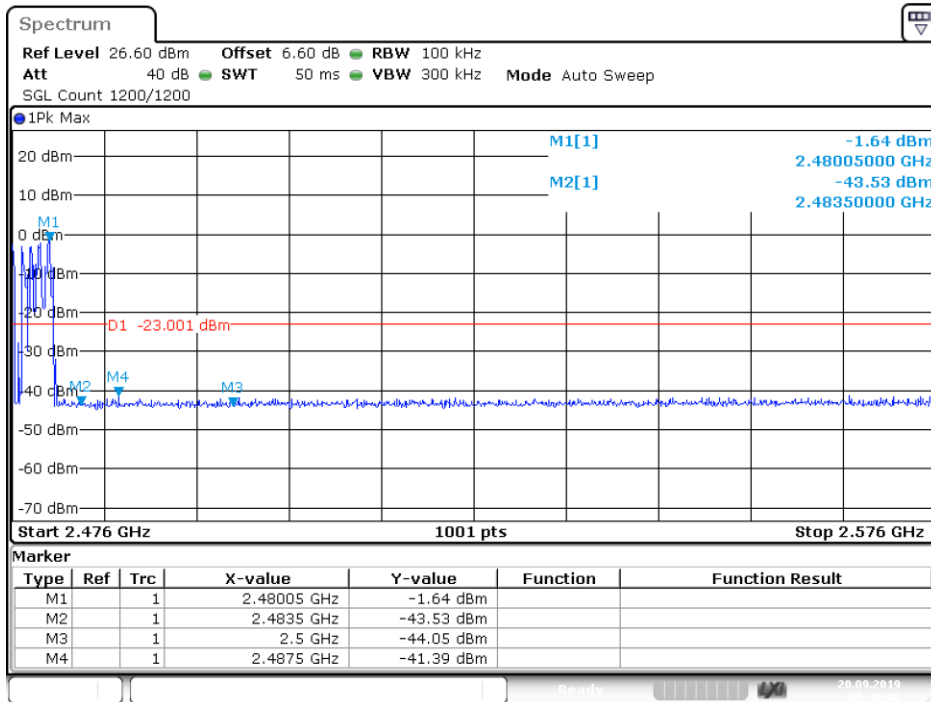

Date: 22.AUG.2019 05:40:46

Band Edge NVNT 2-DH1 2480MHz Ant1 No-Hopping Emission

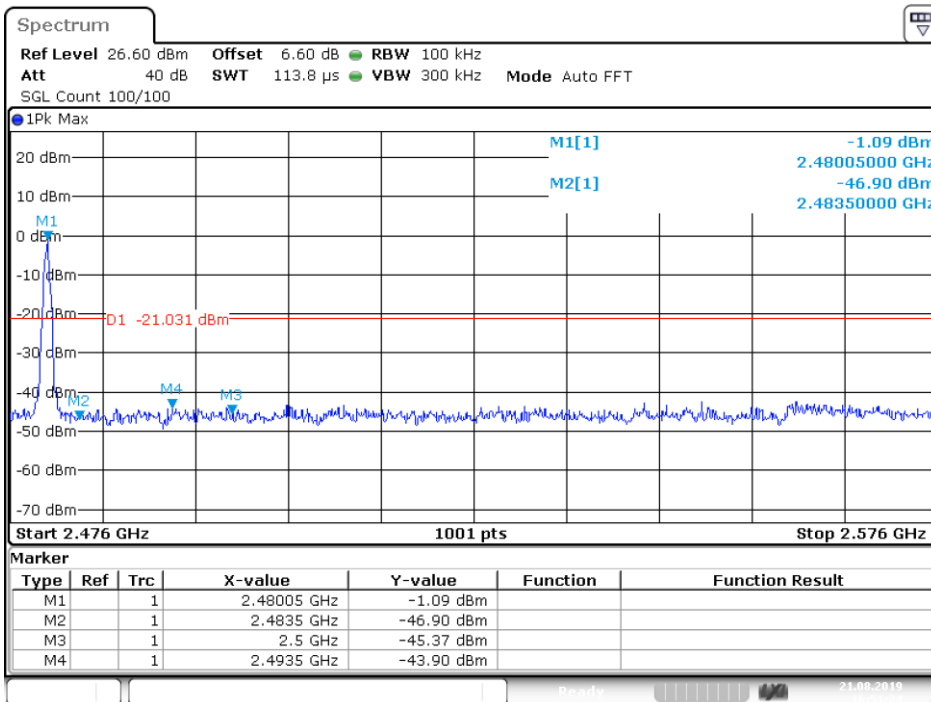

Date: 21.AUG.2019 16:51:24

Band Edge NVLT 3-DH1 2402MHz Ant1 Hopping Emission

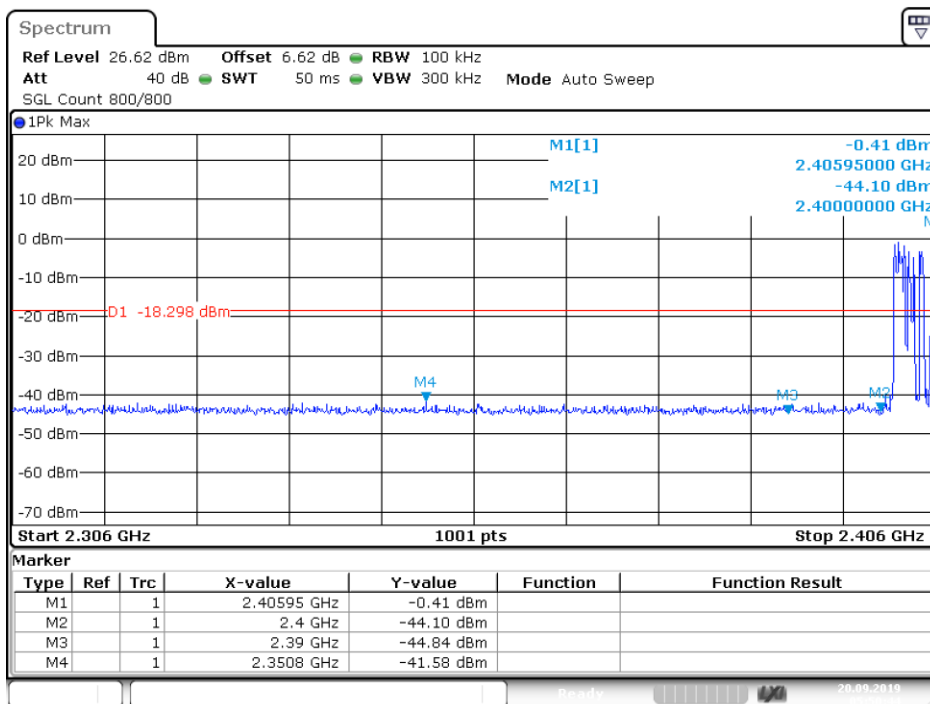

Date: 22.AUG.2019 05:50:43

Band Edge NVNT 3-DH1 2402MHz Ant1 No-Hopping Emission

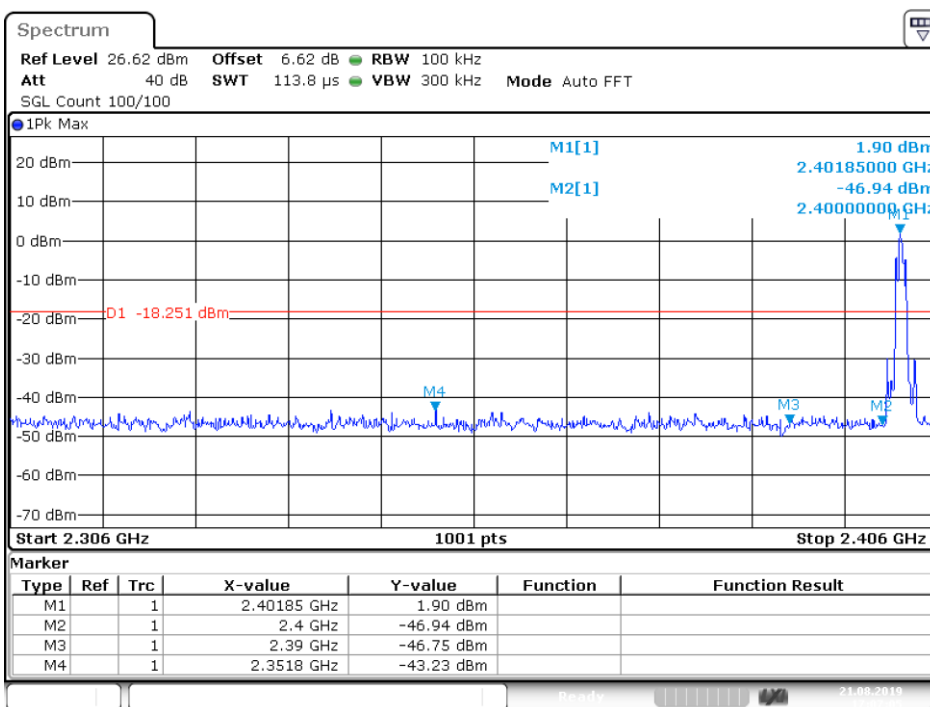

Date: 21.AUG.2019 17:07:05

Band Edge NVLT 3-DH1 2480MHz Ant1 Hopping Emission

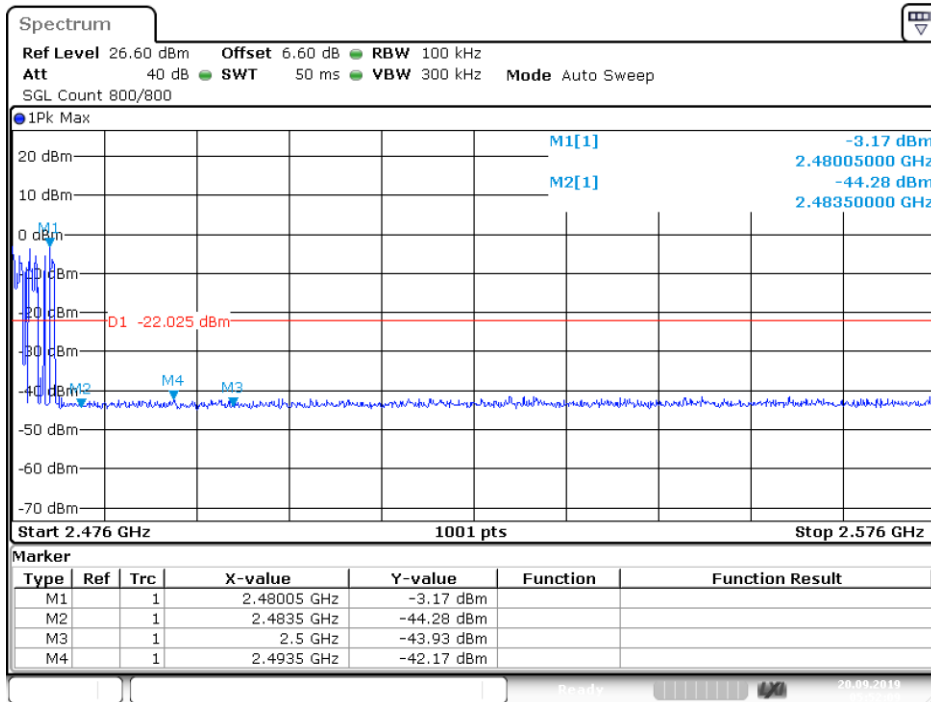

Band Edge NVNT 3-DH1 2480MHz Ant1 No-Hopping Emission

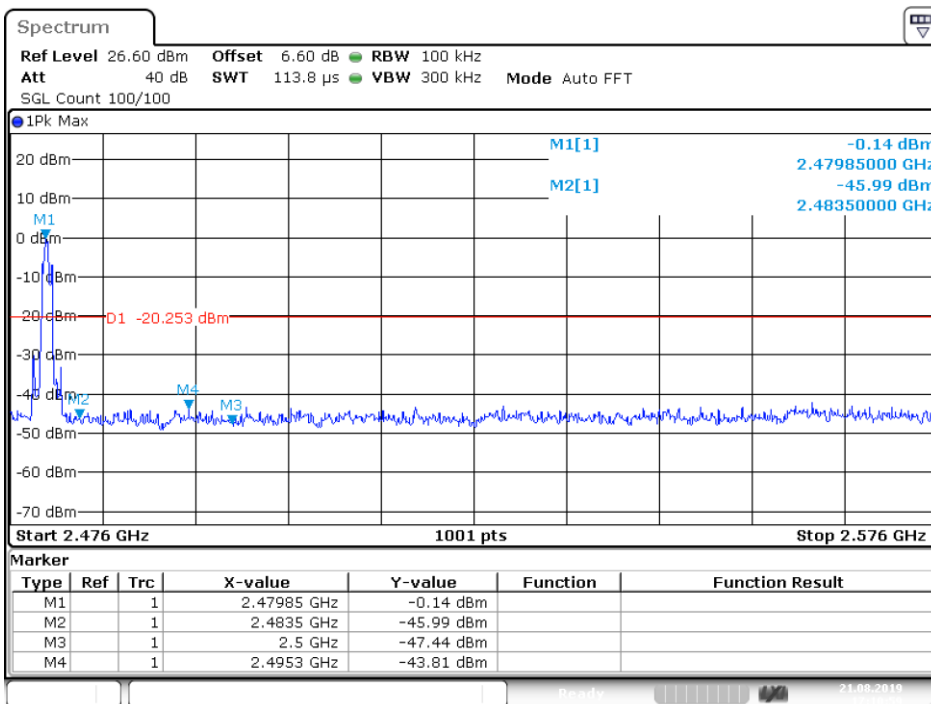

10. POWER LINE CONDUCTED EMISSIONS

10.1. Block Diagram of Test Setup

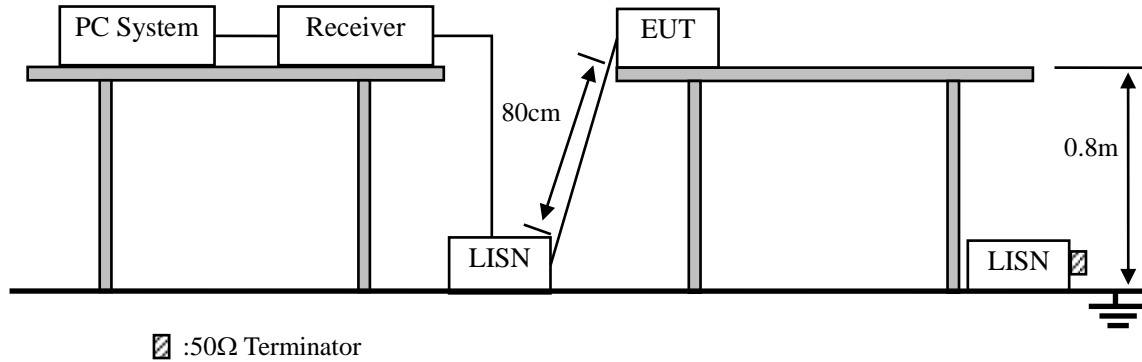

10.2. Limit

Frequency	Maximum RF Line Voltage	
	Quasi-Peak Level dB(μ V)	Average Level dB(μ V)
150kHz ~ 500kHz	66 ~ 56*	56 ~ 46*
500kHz ~ 5MHz	56	46
5MHz ~ 30MHz	60	50

Notes: 1. * Decreasing linearly with logarithm of frequency.

2. The lower limit shall apply at the transition frequencies.

10.3. Test Procedure

- (1) The EUT was placed on a non-metallic table, 80cm above the ground plane.
- (2) Setup the EUT and simulator as shown in 10.1
- (3) The EUT Power connected to the power mains through a power adapter and a line impedance stabilization network (L.I.S.N1). The other peripheral devices power cord connected to the power mains through a line impedance stabilization network (L.I.S.N2), this provided a 50-ohm coupling impedance for the EUT (Please refer to the block diagram of the test setup and photographs). Both sides of power line were checked for maximum conducted interference. In order to find the maximum emission, the relative positions of equipments and all of the interface cables were changed according to ANSI C63.10 :2013on conducted Emission test.
- (4) The bandwidth of test receiver is set at 10KHz.
- (5) The frequency range from 150 KHz to 30MHz is checked.

10.4. Test Result

PASS. (See below detailed test data)

Note: If peak Result comply with AV limit, QP and AV Result is deemed to comply with AV limit

EUT Description	Smart handheld printer	Model No.	XPOS-I100
Temperature	24°C	Humidity	56%
Pol	Line	Test date	2019/8/9
Test Voltage	AC 120V/ 60Hz	Test mode	GFSK (2402MHz)

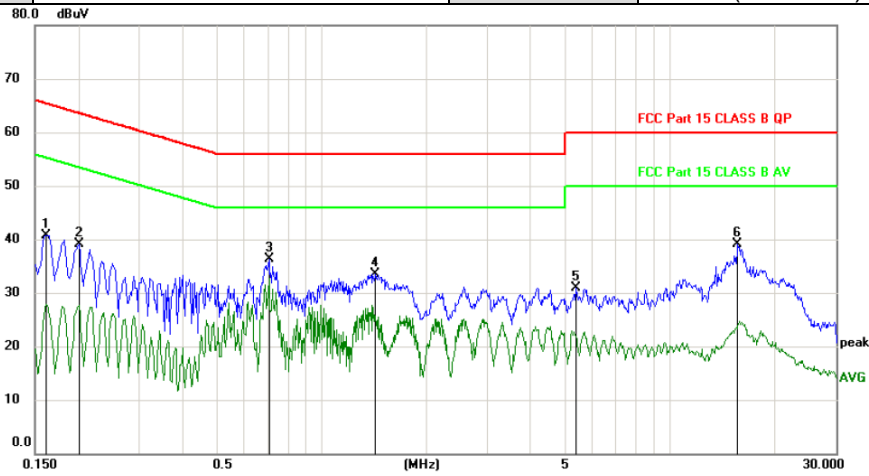

No.	Mk.	Freq.	Reading Level	Correct Factor	Measurement	Limit	Margin	Detector	Comment
		MHz	dBuV	dB	dBuV	dBuV	dB		
1		0.1620	31.13	9.66	40.79	65.36	-24.57	peak	
2		0.2010	29.45	9.67	39.12	63.57	-24.45	peak	
3	*	0.7046	26.52	9.74	36.26	56.00	-19.74	peak	
4		1.4275	23.68	9.81	33.49	56.00	-22.51	peak	
5		5.3730	20.73	10.17	30.90	60.00	-29.10	peak	
6		15.7050	28.60	10.43	39.03	60.00	-20.97	peak	

Pol	Neutral
------------	---------

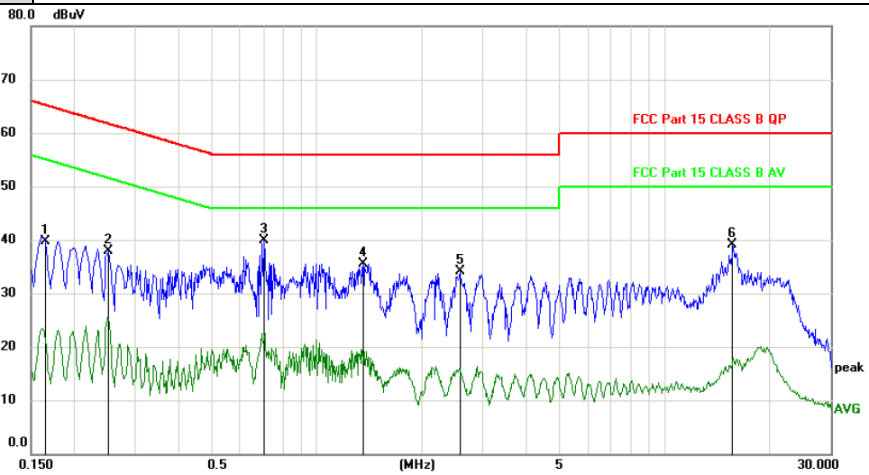

No.	Mk.	Freq.	Reading Level	Correct Factor	Measurement	Limit	Margin	Detector	Comment
		MHz	dBuV	dB	dBuV	dBuV	dB		
1		0.1650	30.07	9.66	39.73	65.21	-25.48	peak	
2		0.2519	28.25	9.69	37.94	61.69	-23.75	peak	
3	*	0.7017	30.22	9.74	39.96	56.00	-16.04	peak	
4		1.3528	25.67	9.81	35.48	56.00	-20.52	peak	
5		2.5739	24.12	9.96	34.08	56.00	-21.92	peak	
6		15.6867	28.73	10.43	39.16	60.00	-20.84	peak	

*:Maximum data x:Over limit !:over margin

Note: Measurement=Reading Level+Correc Factor. Factor=(LISN or ISN or PLC or Current Probe)Factor+Cable

Remark: All modes have been tested, and only worst data of GFSK (2402MHz) was listed in this report.

11.ANTENNA REQUIREMENTS

11.1.Limit

For intentional device, according to FCC 47 CFR Section 15.203, an intentional radiator shall be designed to ensure that no antenna other than that furnished by the responsible party shall be used with the device. And according to FCC 47 CFR Section 15.247 (b), if transmitting antennas of directional gain greater than 6dBi are used, the power shall be reduced by the amount in dB that the directional gain of the antenna exceeds 6dBi.

11.2.Result

The EUT antenna is PIFA antenna. It complies with the standard requirement.

12. TEST SETUP PHOTO

12.1. Photos of Radiated emission

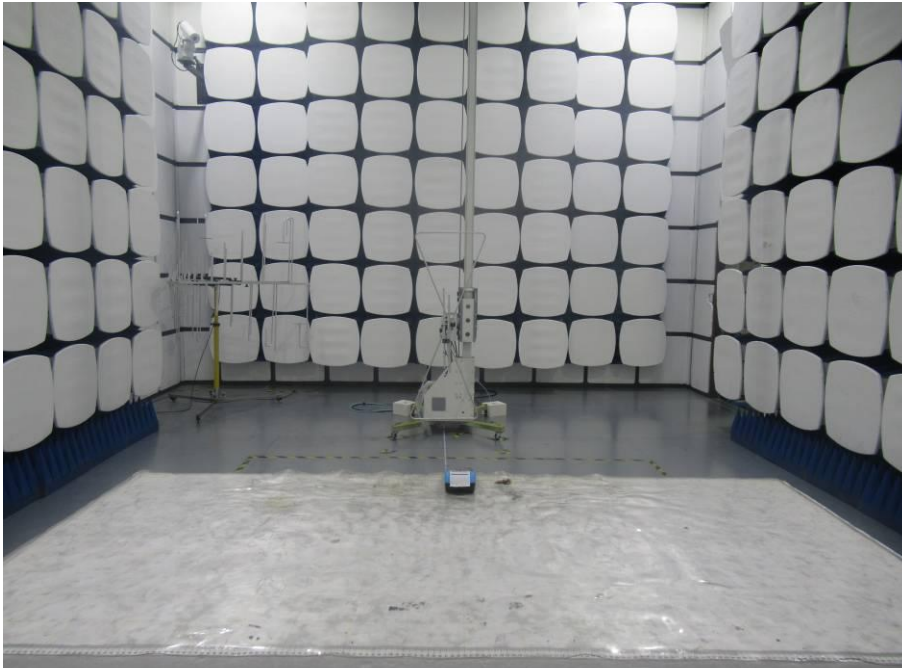

12.2.Photos of Conducted Emission test



13.PHOTOS OF EUT

Please refer to report A1907043-C01-R11.

-----THE END OF REPORT-----