

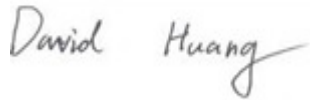

# RF TEST REPORT



Report No.: 17070190-FCC-R1

Supersede Report No.: N/A

Applicant	AOC	
Product Name	Tablet PC	
Model No.	A831L	
Serial No.	N/A	
Test Standard	FCC Part 22(H):2016 ;FCC Part 24(E):2016; ANSI/TIA-603-D: 2010	
Test Date	March 10 to April 04, 2017	
Issue Date	April 05, 2017	
Test Result	<input checked="" type="checkbox"/> Pass <input type="checkbox"/> Fail	
Equipment complied with the specification	<input checked="" type="checkbox"/>	
Equipment did not comply with the specification	<input type="checkbox"/>	
		
Loren Luo Test Engineer	David Huang Checked By	
This test report may be reproduced in full only Test result presented in this test report is applicable to the tested sample only		

Issued by:

**SIEMIC (SHENZHEN-CHINA) LABORATORIES**

Zone A, Floor 1, Building 2 Wan Ye Long Technology Park

South Side of Zhoushi Road, Bao' an District, Shenzhen, Guangdong China 518108

Phone: +86 0755 2601 4629801 Email: [China@siemic.com.cn](mailto:China@siemic.com.cn)

## Laboratories Introduction

SIEMIC, headquartered in the heart of Silicon Valley, with superior facilities in US and Asia, is one of the leading independent testing and certification facilities providing customers with one-stop shop services for Compliance Testing and Global Certifications.



In addition to testing and certification, SIEMIC provides initial design reviews and compliance management throughout a project. Our extensive experience with China, Asia Pacific, North America, European, and International compliance requirements, assures the fastest, most cost effective way to attain regulatory compliance for the global markets.

### Accreditations for Conformity Assessment

Country/Region	Scope
USA	EMC, RF/Wireless, SAR, Telecom
Canada	EMC, RF/Wireless, SAR, Telecom
Taiwan	EMC, RF, Telecom, SAR, Safety
Hong Kong	RF/Wireless, SAR, Telecom
Australia	EMC, RF, Telecom, SAR, Safety
Korea	EMI, EMS, RF, SAR, Telecom, Safety
Japan	EMI, RF/Wireless, SAR, Telecom
Singapore	EMC, RF, SAR, Telecom
Europe	EMC, RF, SAR, Telecom, Safety

Test Report	17070190-FCC-R1
Page	3 of 88

This page has been left blank intentionally.

# CONTENTS

1. REPORT REVISION HISTORY .....	5
2. CUSTOMER INFORMATION .....	5
3. TEST SITE INFORMATION .....	5
4. EQUIPMENT UNDER TEST (EUT) INFORMATION .....	6
5. TEST SUMMARY .....	9
6. MEASUREMENTS, EXAMINATION AND DERIVED RESULTS .....	10
6.1 RF EXPOSURE (SAR).....	10
6.2 RF OUTPUT POWER.....	11
6.3 PEAK-AVERAGE RATIO.....	23
6.4 OCCUPIED BANDWIDTH.....	27
6.5 SPURIOUS EMISSIONS AT ANTENNA TERMINALS.....	38
6.6 SPURIOUS RADIATED EMISSIONS.....	51
6.7 BAND EDGE.....	57
6.8 FREQUENCY STABILITY .....	67
ANNEX A. TEST INSTRUMENT.....	71
ANNEX B. EUT AND TEST SETUP PHOTOGRAPHS.....	73
ANNEX C. TEST SETUP AND SUPPORTING EQUIPMENT.....	84
ANNEX C.II. EUT OPERATING CONKITIONS .....	86
ANNEX D. USER MANUAL / BLOCK DIAGRAM / SCHEMATICS / PARTLIST .....	87
ANNEX E. DECLARATION OF SIMILARITY.....	88

## 1. Report Revision History

Report No.	Report Version	Description	Issue Date
17070190-FCC-R1	NONE	Original	April 05, 2017

## 2. Customer information

Applicant Name	AOC
Applicant Add	14F-5, NO.258, Liancheng Rd., Zhonghe Dist., New Taipei City, Taiwan
Manufacturer	China Great Wall Computer Shenzhen Co., Ltd
Manufacturer Add	No.Great wall Computer Industrial Park,Bao Shi East Road,Bao' an Bistrict,Shenzhen,P.R.China

## 3. Test site information

Lab performing tests	SIEMIC (Shenzhen-China) LABORATORIES
Lab Address	Zone A, Floor 1, Building 2 Wan Ye Long Technology Park South Side of Zhoushi Road, Bao' an District, Shenzhen, Guangdong China 518108
FCC Test Site No.	718246
IC Test Site No.	4842E-1
Test Software	Radiated Emission Program-To Shenzhen(ICP-03A1)

## 4. Equipment under Test (EUT) Information

Description of EUT:	Tablet PC
Main Model:	A831L
Serial Model:	N/A
Date EUT received:	March 10, 2017
Test Date(s):	March 10 to April 04, 2017
Equipment Category :	PCE
Antenna Gain:	GSM850: -0.7dBi PCS1900: -0.8dBi UMTS-FDD Band V: -0.7dBi UMTS-FDD Band II: -0.8dBi LTE Band II: -0.8dBi LTE Band IV: -0.7dBi LTE Band VII: -1dBi LTE Band XVII: -0.7dBi WIFI: 1.18dBi Bluetooth/BLE: 1.18dBi GPS: 0.22dBi
Antenna Type:	PIFA antenna
Type of Modulation:	GSM / GPRS: GMSK EGPRS: GMSK,8PSK UMTS-FDD: QPSK LTE Band: QPSK, 16QAM 802.11b/g/n: DSSS, OFDM Bluetooth: GFSK, $\pi$ /4DQPSK, 8DPSK BLE: GFSK GPS:BPSK

RF Operating Frequency (ies):

GSM850 TX: 824.2 ~ 848.8 MHz; RX: 869.2 ~ 893.8 MHz  
 PCS1900 TX: 1850.2 ~ 1909.8 MHz; RX: 1930.2 ~ 1989.8 MHz  
 UMTS-FDD Band V TX: 826.4 ~ 846.6 MHz; RX: 871.4 ~ 891.6 MHz  
 UMTS-FDD Band II TX: 1852.4 ~ 1907.6 MHz;  
 RX: 1932.4 ~ 1987.6 MHz  
 LTE Band II TX: 1850.7 ~ 1909.3 MHz; RX : 1930.7 ~ 1989.3 MHz  
 LTE Band IV TX: 1710.7 ~ 1754.3 MHz; RX : 2110.7 ~ 2154.3 MHz  
 LTE Band VII TX: 2502.5 ~ 2567.5 MHz; RX : 2622.5 ~ 2687.5 MHz  
 LTE Band XVII TX: 706.5 ~ 713.5 MHz; RX : 736.5 ~ 743.5 MHz  
 WIFI: 802.11b/g/n(20M): 2412-2462 MHz  
 WIFI: 802.11n(40M): 2422-2452 MHz  
 Bluetooth& BLE: 2402-2480 MHz  
 GPS: 1575.42 MHz

Maximum Conducted  
 AV Power to Antenna:

GSM Voice: GSM850: 32.91 dBm  
 PCS1900: 30.48 dBm  
 GPRS: GSM850: 32.89 dBm  
 PCS1900: 30.46 dBm  
 EGPRS(MCS5): GSM850: 29.63 dBm  
 PCS1900: 29.12 dBm  
 RMC: UMTS-FDD Band V: 23.07 dBm  
 UMTS-FDD Band II: 23.42 dBm  
 HSUPA: UMTS-FDD Band V: 22.14 dBm  
 UMTS-FDD Band II: 22.35 dBm  
 HSDPA: UMTS-FDD Band V: 22.17 dBm  
 UMTS-FDD Band II: 22.38 dBm

GSM Voice:GSM850: 30.06dBm / ERP  
                   PCS1900: 29.68dBm / EIRP  
 GPRS:GSM850: 30.03dBm / ERP  
                   PCS1900: 29.66 dBm / EIRP  
 EGPRS(MCS5):GSM850: 26.78 dBm / ERP  
                   PCS1900: 28.32dBm / EIRP  
 ERP/EIRP:  
 RMC:UMTS-FDD Band V: 20.22 dBm / ERP  
                   UMTS-FDD Band II: 22.62 dBm / EIRP  
 HSDPA:UMTS-FDD Band V: 19.29 dBm / ERP  
                   UMTS-FDD Band II: 21.55 dBm / EIRP  
 HSUPA:UMTS-FDD Band V: 19.32 dBm / ERP  
                   UMTS-FDD Band II: 21.58 dBm / EIRP  
  
 GSM 850: 124CH  
 PCS1900: 299CH  
 UMTS-FDD Band V : 102CH  
 UMTS-FDD Band II : 277CH  
 Number of Channels:  
 WIFI :802.11b/g/n(20M): 11CH  
 WIFI :802.11n(40M): 7CH  
 Bluetooth: 79CH  
 BLE: 40CH  
 GPS:1CH  
  
 Port:                  USB Port, Earphone Port  
  
 Adapter:  
 Model: SC/10WA050200US  
 Input Power:        Input: AC100-240V~50/60Hz,0.5A  
                           Output: DC 5.0V,2A  
                           Battery :  
                           Spec: 3.8V,19Wh,5000mAh  
  
 Trade Name :          AOC  
  
 GPRS/ EGPRS Multi-slot class   8/10/12  
  
 FCC ID:                  2AEB5-A831L



## 5. Test Summary

The product was tested in accordance with the following specifications.

All testing has been performed according to below product classification:

FCC Rules	Description of Test	Result
§ 1.1307; § 2.1093	RF Exposure (SAR)	Compliance
§2.1046; § 22.913(a); § 24.232(c); § 27.50(c.10) ;	RF Output Power	Compliance
§ 24.232 (d) ;	Peak-Average Ratio	Compliance
§ 2.1049; § 22.905; § 22.917; § 24.238;	99% & -26 dB Occupied Bandwidth	Compliance
§ 2.1051; § 22.917(a); § 24.238(a);	Spurious Emissions at Antenna Terminal	Compliance
§ 2.1053; § 22.917(a); § 24.238(a);	Field Strength of Spurious Radiation	Compliance
§ 22.917(a); § 24.238(a);	Out of band emission, Band Edge	Compliance
§ 2.1055; § 22.355; § 24.235;	Frequency stability vs. temperature Frequency stability vs. voltage	Compliance

Note: Testing was performed by configuring EUT to maximum output power status, the declared output power class for different

### Measurement Uncertainty

Emissions		
Test Item	Description	Uncertainty
Band Edge and Radiated Spurious Emissions	Confidence level of approximately 95% (in the case where distributions are normal), with a coverage factor of 2 (for EUTs < 0.5m X 0.5m X 0.5m)	+5.6dB/-4.5dB
-	-	-

## **6. MEASUREMENTS, EXAMINATION AND DERIVED RESULTS**

### 6.1 RF Exposure (SAR)

Test Result: Pass

The EUT is a portable device, thus requires SAR evaluation;

Please refer to RF Exposure Evaluation Report: 17070190-FCC-H.

## 6.2 RF Output Power

Temperature	22°C
Relative Humidity	53%
Atmospheric Pressure	1010mbar
Test date :	March 13, 2017
Tested By :	Loren Luo

### Requirement(s):

Spec	Item	Requirement	Applicable
§22.913 (a)	a)	ERP:38.45dBm	<input checked="" type="checkbox"/>
§24.232 (c)	b)	EIRP:33dBm	<input checked="" type="checkbox"/>

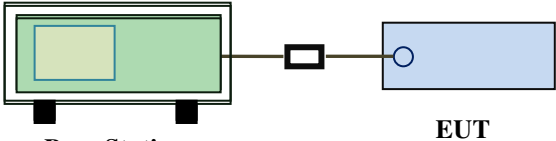
Test Setup	 <p style="text-align: center;">Base Station                      EUT</p>
------------	--

Test Procedure	<p>For Conducted Power:</p> <ul style="list-style-type: none"> <li>- The transmitter output port was connected to base station.</li> <li>- Set EUT at maximum power through base station.</li> <li>- Select lowest, middle, and highest channels for each band and different test mode.</li> </ul> <p>For ERP/EIRP:</p> <p>According with KDB 971168 v02r02</p> <ul style="list-style-type: none"> <li>- The transmitter was placed on a wooden turntable, and it was transmitting into a non-radiating load which was also placed on the turntable.</li> <li>- The measurement antenna was placed at a distance of 3 meters from the EUT. During the tests, the antenna height and polarization as well as EUT azimuth were varied in order to identify the maximum level of emissions from the EUT. The test was performed by placing the EUT on 3-orthogonal axis.</li> <li>- The frequency range up to tenth harmonic of the fundamental frequency was investigated.</li> </ul>
----------------	---

	<ul style="list-style-type: none"> <li>- Remove the EUT and replace it with substitution antenna. A signal generator was connected to the substitution antenna by a non-radiating cable. The absolute levels of the spurious emissions were measured by the substitution.</li> <li>- Spurious emissions in dB = 10 log (TX power in Watts/0.001) – the absolute level</li> <li>- Spurious attenuation limit in dB = 43 + 10 Log10 (power out in Watts).</li> </ul>
Remark	
Result	<input checked="" type="checkbox"/> Pass <input type="checkbox"/> Fail

Test Data     Yes                       N/A  
 Test Plot     Yes (See below)             N/A

## Conducted Power

### GSM Mode:

Burst Average Power (dBm);								
Band	GSM850				PCS1900			
Channel	128	190	251	Tune up Power tolerant	512	661	810	Tune up Power tolerant
Frequency (MHz)	824.2	836.6	848.8	/	1850.2	1880	1909.8	/
GSM Voice (1 uplink),GMSK	<b>32.91</b>	32.84	32.80	32.5±1	30.46	<b>30.48</b>	30.47	30±1
GPRS Multi-Slot Class 8 (1 uplink),GMSK	<b>32.89</b>	32.84	32.79	32.5±1	30.45	<b>30.46</b>	30.43	30±1
GPRS Multi-Slot Class 10 (2 uplink) GMSK	32.08	32.04	32.07	32±1	29.71	29.77	29.73	29.5±1
GPRS Multi-Slot Class 12 (4 uplink) GMSK	29.11	29.07	29.09	29+1	27.02	27.07	27.03	27±1
EGPRS Multi-Slot Class 8 (1 uplink) GMSK MCS1	<b>32.85</b>	32.78	32.73	32.5±1	30.43	<b>30.46</b>	30.42	30±1
EGPRS Multi-Slot Class 10 (2 uplink) GMSK MCS1	32.05	32.01	31.95	32±1	29.65	29.64	29.65	29.5±1
EGPRS Multi-Slot Class 12 (4 uplink) GMSK MCS1	29.04	29.03	28.98	29+1	27.06	27.04	27.01	27±1
EGPRS Multi-Slot Class 8 (1 uplink) 8PSK MCS5	<b>29.63</b>	29.52	29.47	29.5±1	29.05	<b>29.12</b>	29.01	29±1
EGPRS Multi-Slot Class 10 (2 uplink) 8PSK MCS5	28.71	28.74	28.72	28.5±1	28.41	28.29	28.23	28±1
EGPRS Multi-Slot Class 12 (4 uplink) 8PSK MCS5	25.59	25.73	25.71	25.5±1	25.81	25.61	25.49	25.5±1

Test Report	17070190-FCC-R1
Page	14 of 88

Remark :

GPRS, CS1 coding scheme.

EGPRS, MCS1 coding scheme.

EGPRS, MCS5 coding scheme.

Multi-Slot Class 8 , Support Max 4 downlink, 1 uplink , 5 working link

Multi-Slot Class 10 , Support Max 4 downlink, 2 uplink , 5 working link

Multi-Slot Class 12 , Support Max 4 downlink, 4 uplink , 5 working link

## UMTS Mode:

### UMTS-FDD Band V

Band/ Time Slot configuration	Channel	Frequency	Average power (dBm)	Tune up Power tolerant
RMC 12.2kbps	4132	826.4	<b>23.07</b>	23±1
	4175	835	23.06	23±1
	4233	846.6	23.02	23±1
HSDPA Subtest1	4132	826.4	21.95	22±1
	4175	835	21.91	22±1
	4233	846.6	21.93	22±1
HSDPA Subtest2	4132	826.4	22.13	22±1
	4175	835	22.10	22±1
	4233	846.6	<b>22.14</b>	22±1
HSDPA Subtest3	4132	826.4	21.92	22±1
	4175	835	21.97	22±1
	4233	846.6	21.99	22±1
HSDPA Subtest4	4132	826.4	22.11	22±1
	4175	835	22.14	22±1
	4233	846.6	22.14	22±1
HSUPA Subtest1	4132	826.4	22.02	22±1
	4175	835	22.10	22±1
	4233	846.6	22.06	22±1
HSUPA Subtest2	4132	826.4	21.94	22±1
	4175	835	21.92	22±1
	4233	846.6	21.99	22±1
HSUPA Subtest3	4132	826.4	22.13	22±1
	4175	835	22.09	22±1
	4233	846.6	22.10	22±1
HSUPA Subtest4	4132	826.4	22.13	22±1
	4175	835	<b>22.17</b>	22±1
	4233	846.6	22.06	22±1
HSUPA Subtest5	4132	826.4	21.96	22±1
	4175	835	21.91	22±1
	4233	846.6	22.01	22±1

## UMTS-FDD Band II

Band/ Time Slot configuration	Channel	Frequency	Average power (dBm)	Tune up Power tolerant
RMC 12.2kbps	9262	1852.4	23.26	23±1
	9400	1880	<b>23.42</b>	23±1
	9538	1907.6	23.32	23±1
HSDPA Subtest1	9262	1852.4	<b>22.35</b>	22.3±1
	9400	1880	22.29	22.3±1
	9538	1907.6	22.30	22.3±1
HSDPA Subtest2	9262	1852.4	22.16	22.3±1
	9400	1880	22.12	22.3±1
	9538	1907.6	22.17	22.3±1
HSDPA Subtest3	9262	1852.4	22.04	22.3±1
	9400	1880	22.03	22.3±1
	9538	1907.6	22.07	22.3±1
HSDPA Subtest4	9262	1852.4	22.09	22.3±1
	9400	1880	22.14	22.3±1
	9538	1907.6	22.11	22.3±1
HSUPA Subtest1	9262	1852.4	22.34	22.3±1
	9400	1880	22.33	22.3±1
	9538	1907.6	<b>22.38</b>	22.3±1
HSUPA Subtest2	9262	1852.4	22.12	22.3±1
	9400	1880	22.16	22.3±1
	9538	1907.6	22.09	22.3±1
HSUPA Subtest3	9262	1852.4	22.15	22.3±1
	9400	1880	22.16	22.3±1
	9538	1907.6	22.03	22.3±1
HSUPA Subtest4	9262	1852.4	22.15	22.3±1
	9400	1880	22.12	22.3±1
	9538	1907.6	22.09	22.3±1
HSUPA Subtest5	9262	1852.4	22.14	22.3±1
	9400	1880	22.15	22.3±1
	9538	1907.6	22.17	22.3±1



## ERP & EIRP

### GSM Voice

#### ERP for Cellular Band (Part 22H)

Frequency (MHz)	Substituted level (dBm)	Antenna Polarization	Antenna Gain correction (dBi)	Cable Loss (dB)	Absolute Level (dBm)	Limit (dBm)
824.2	23.79	V	6.8	0.53	<b>30.06</b>	38.45
824.2	22.19	H	6.8	0.53	28.46	38.45
836.6	23.71	V	6.8	0.53	29.98	38.45
836.6	22.1	H	6.8	0.53	28.37	38.45
848.8	23.57	V	6.9	0.53	29.94	38.45
848.8	21.96	H	6.9	0.53	28.33	38.45

#### EIRP for PCS Band (Part 24E)

Frequency (MHz)	Substituted level (dBm)	Antenna Polarization	Antenna Gain correction (dBi)	Cable Loss (dB)	Absolute Level (dBm)	Limit (dBm)
1850.2	22.63	V	7.88	0.85	29.66	33
1850.2	20.81	H	7.88	0.85	27.84	33
1880	22.65	V	7.88	0.85	<b>29.68</b>	33
1880	20.83	H	7.88	0.85	27.86	33
1909.8	22.66	V	7.86	0.85	29.67	33
1909.8	20.84	H	7.86	0.85	27.85	33

**GPRS:**

**ERP for Cellular Band (Part 22H)**

Frequency (MHz)	Substituted level (dBm)	Antenna Polarization	Antenna Gain correction (dBi)	Cable Loss (dB)	Absolute Level (dBm)	Limit (dBm)
824.2	23.76	V	6.8	0.53	<b>30.03</b>	38.45
824.2	22.16	H	6.8	0.53	28.43	38.45
836.6	23.71	V	6.8	0.53	29.98	38.45
836.6	22.1	H	6.8	0.53	28.37	38.45
848.8	23.56	V	6.9	0.53	29.93	38.45
848.8	21.95	H	6.9	0.53	28.32	38.45

**EIRP for PCS Band (Part 24E)**

Frequency (MHz)	Substituted level (dBm)	Antenna Polarization	Antenna Gain correction (dBi)	Cable Loss (dB)	Absolute Level (dBm)	Limit (dBm)
1850.2	22.62	V	7.88	0.85	29.65	33
1850.2	20.8	H	7.88	0.85	27.83	33
1880	22.63	V	7.88	0.85	<b>29.66</b>	33
1880	20.81	H	7.88	0.85	27.84	33
1909.8	22.62	V	7.86	0.85	29.63	33
1909.8	20.81	H	7.86	0.85	27.82	33

**EGPRS (MCS5):**

**ERP for Cellular Band (Part 22H)**

Frequency (MHz)	Substituted level (dBm)	Antenna Polarization	Antenna Gain correction (dBi)	Cable Loss (dB)	Absolute Level (dBm)	Limit (dBm)
824.2	20.35	V	6.8	0.53	26.62	38.45
824.2	18.61	H	6.8	0.53	24.88	38.45
836.6	20.4	V	6.8	0.53	26.67	38.45
836.6	18.66	H	6.8	0.53	24.93	38.45
848.8	20.41	V	6.9	0.53	<b>26.78</b>	38.45
848.8	18.71	H	6.9	0.53	25.08	38.45

**EIRP for PCS Band (Part 24E)**

Frequency (MHz)	Substituted level (dBm)	Antenna Polarization	Antenna Gain correction (dBi)	Cable Loss (dB)	Absolute Level (dBm)	Limit (dBm)
1850.2	21.29	V	7.88	0.85	<b>28.32</b>	33
1850.2	19.56	H	7.88	0.85	26.59	33
1880	21.22	V	7.88	0.85	28.25	33
1880	19.49	H	7.88	0.85	26.52	33
1909.8	21.2	V	7.86	0.85	28.21	33
1909.8	19.47	H	7.86	0.85	26.48	33

## RMC

### ERP for UMTS-FDD Band V (Part 22H)

Frequency (MHz)	Substituted level (dBm)	Antenna Polarization	Antenna Gain correction (dBi)	Cable Loss (dB)	Absolute Level (dBm)	Limit (dBm)
826.4	13.95	V	6.8	0.53	<b>20.22</b>	38.45
826.4	12.99	H	6.8	0.53	19.26	38.45
835	13.94	V	6.8	0.53	20.21	38.45
835	12.98	H	6.8	0.53	19.25	38.45
846.6	13.8	V	6.9	0.53	20.17	38.45
846.6	12.84	H	6.9	0.53	19.21	38.45

### EIRP for UMTS-FDD Band II (Part 24E)

Frequency (MHz)	Substituted level (dBm)	Antenna Polarization	Antenna Gain correction (dBi)	Cable Loss (dB)	Absolute Level (dBm)	Limit (dBm)
1852.4	15.43	V	7.88	0.85	22.46	33
1852.4	14.5	H	7.88	0.85	21.53	33
1880	15.59	V	7.88	0.85	<b>22.62</b>	33
1880	14.71	H	7.88	0.85	21.74	33
1907.6	15.51	V	7.86	0.85	22.52	33
1907.6	14.6	H	7.86	0.85	21.61	33

## HSDPA

### ERP for UMTS-FDD Band V (Part 22H)

Frequency (MHz)	Substituted level (dBm)	Antenna Polarization	Antenna Gain correction (dBi)	Cable Loss (dB)	Absolute Level (dBm)	Limit (dBm)
826.4	13.01	V	6.8	0.53	19.28	38.45
826.4	12.07	H	6.8	0.53	18.34	38.45
835	13.02	V	6.8	0.53	<b>19.29</b>	38.45
835	12.08	H	6.8	0.53	18.35	38.45
846.6	12.92	V	6.9	0.53	19.29	38.45
846.6	11.98	H	6.9	0.53	18.35	38.45

### EIRP for UMTS-FDD Band II (Part 24E)

Frequency (MHz)	Substituted level (dBm)	Antenna Polarization	Antenna Gain correction (dBi)	Cable Loss (dB)	Absolute Level (dBm)	Limit (dBm)
1852.4	14.52	V	7.88	0.85	<b>21.55</b>	33
1852.4	13.64	H	7.88	0.85	20.67	33
1880	14.46	V	7.88	0.85	21.49	33
1880	13.51	H	7.88	0.85	20.54	33
1907.6	14.49	V	7.86	0.85	21.50	33
1907.6	13.62	H	7.86	0.85	20.63	33

## HSUPA

### ERP for UMTS-FDD Band V (Part 22H)

Frequency (MHz)	Substituted level (dBm)	Antenna Polarization	Antenna Gain correction (dBi)	Cable Loss (dB)	Absolute Level (dBm)	Limit (dBm)
826.4	13.01	V	6.8	0.53	19.28	38.45
826.4	12.06	H	6.8	0.53	18.33	38.45
835	13.05	V	6.8	0.53	<b>19.32</b>	38.45
835	12.09	H	6.8	0.53	18.36	38.45
846.6	12.88	V	6.9	0.53	19.25	38.45
846.6	11.92	H	6.9	0.53	18.29	38.45

### EIRP for UMTS-FDD Band II (Part 24E)

Frequency (MHz)	Substituted level (dBm)	Antenna Polarization	Antenna Gain correction (dBi)	Cable Loss (dB)	Absolute Level (dBm)	Limit (dBm)
1852.4	14.51	V	7.88	0.85	21.54	33
1852.4	13.58	H	7.88	0.85	20.61	33
1880	14.5	V	7.88	0.85	21.53	33
1880	13.57	H	7.88	0.85	20.60	33
1907.6	14.57	V	7.86	0.85	<b>21.58</b>	33
1907.6	13.56	H	7.86	0.85	20.57	33

### 6.3 Peak-Average Ratio

Temperature	22°C
Relative Humidity	53%
Atmospheric Pressure	1010mbar
Test date :	March 13, 2017
Tested By :	Loren Luo

Requirement(s):

Spec	Item	Requirement	Applicable
§24.232(d)	a)	The peak-to-average ratio (PAR) of the transmission may not exceed 13dB.	<input checked="" type="checkbox"/>

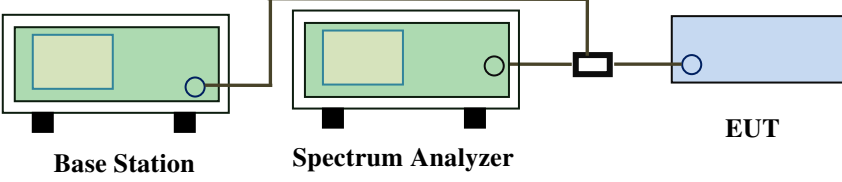
Test Setup	 <p>The diagram illustrates the test setup. On the left is a green box labeled 'Base Station'. A cable connects it to a second green box labeled 'Spectrum Analyzer'. Another cable connects the Spectrum Analyzer to a small black box, which is then connected to a blue box labeled 'EUT' (Equipment Under Test).</p>
------------	---

Test Procedure	<p><b>According with KDB 971168 v02r02</b></p> <p><b>5.7.2 Alternate procedure for PAPR</b></p> <p><b>5.1.2 Peak power measurements with a peak power meter</b></p> <p>The total peak output power may be measured using a broadband peak RF power meter. The power meter must have a video bandwidth that is greater than or equal to the emission bandwidth and utilize a fast-responding diode detector.</p> <p><b>5.2.3 Average power measurement with average power meter</b></p> <p>As an alternative to the use of a spectrum/signal analyzer or EMI receiver to perform a measurement of the total in-band average output power, a wideband RF average power meter with a thermocouple detector or equivalent can be used under certain conditions</p> <p>If the EUT can be configured to transmit continuously (i.e., the burst duty cycle <math>\geq 98\%</math>) and at all times the EUT is transmitting at its maximum output</p>
----------------	--

Test Report	17070190-FCC-R1
Page	24 of 88

	<p>power level, then a conventional wide-band RF power meter can be used.</p> <p>If the EUT cannot be configured to transmit continuously (i.e., the burst duty cycle &lt; 98%), then there are two options for the use of an average power meter. First, a gated average power meter can be used to perform the measurement if the gating parameters can be adjusted such that the power is measured only over active transmission bursts at maximum output power levels. A conventional average power meter can also be used if the measured burst duty cycle is constant (i.e., duty cycle variations are less than <math>\pm 2</math> percent) by performing the measurement over the on/off burst cycles and then correcting (increasing) the measured level by a factor equal to <math>10\log(1/\text{duty cycle})</math></p>
Remark	
Result	<input checked="" type="checkbox"/> Pass <input type="checkbox"/> Fail

**Test Data**     Yes                       N/A  
**Test Plot**     Yes (See below)             N/A



**GSM : GSM 1900 PK-AV POWER (PART 24E)**

Frequency (MHz)	Conducted power(dBm)		Peak-Average Ratio(PAR)
	Peak	Average	
1850.2	31.5	30.46	1.04
1880	31.59	30.48	1.11
1909.8	31.51	30.47	1.04

**GPRS 1900 PK-AV POWER (PART 24E)**

Frequency (MHz)	Conducted power(dBm)		Peak-Average Ratio(PAR)
	Peak	Average	
1850.2	31.5	30.45	1.05
1880	31.46	30.46	1.00
1909.8	31.42	30.43	0.99

**EGPRS (MSC5) 1900 PK-AV POWER (PART 24E)**

Frequency (MHz)	Conducted power(dBm)		Peak-Average Ratio(PAR)
	Peak	Average	
1850.2	30.33	29.12	1.21
1880	30.38	29.05	1.33
1909.8	30.34	29.01	1.33

**RMC : UMTS-FDD Band 2 PK-AV POWER (PART 24E)**

Frequency (MHz)	Conducted power(dBm)		Peak-Average Ratio(PAR)
	Peak	Average	
1852.4	24.31	23.26	1.05
1880	24.53	23.42	1.11
1907.6	24.42	23.32	1.1

**HSDPA : UMTS-FDD Band 2 PK-AV POWER (PART 24E)**

Frequency (MHz)	Conducted power(dBm)		Peak-Average Ratio(PAR)
	Peak	Average	
1852.4	23.45	22.34	1.11
1880	23.42	22.33	1.09
1907.6	23.44	22.38	1.06

**HSUPA : UMTS-FDD Band 2 PK-AV POWER (PART 24E)**

Frequency (MHz)	Conducted power(dBm)		Peak-Average Ratio(PAR)
	Peak	Average	
1852.4	23.50	22.35	1.15
1880	23.53	22.29	1.24
1907.6	23.57	22.30	1.27

## 6.4 Occupied Bandwidth

Temperature	22°C
Relative Humidity	53%
Atmospheric Pressure	1010mbar
Test date :	March 13&14, 2017
Tested By :	Loren Luo

### Requirement(s):

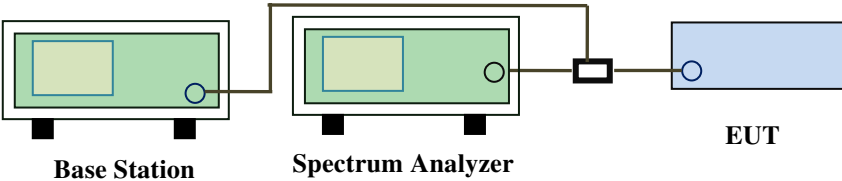
Spec	Item	Requirement	Applicable
§2.1049, §22.917, §22.905 §24.238	a)	99% Occupied Bandwidth(kHz)	<input checked="" type="checkbox"/>
	b)	26 dB Bandwidth(kHz)	<input checked="" type="checkbox"/>
Test Setup	 <p style="text-align: center;">Base Station      Spectrum Analyzer      EUT</p>		
Test Procedure	<ul style="list-style-type: none"> <li>- The EUT was connected to Spectrum Analyzer and Base Station via power divider.</li> <li>- The 99% and 26 dB occupied bandwidth (BW) of the middle channel for the highest RF powers.</li> </ul>		
Remark			
Result	<input checked="" type="checkbox"/> Pass <input type="checkbox"/> Fail		

Test Data     Yes       N/A

Test Plot     Yes (See below)       N/A

**GSM Voice:**

**Cellular Band (Part 22H) result**

Channel	Frequency (MHz)	99% Occupied Bandwidth (kHz)	26 dB Bandwidth (kHz)
128	824.2	245.44	320.5
190	836.6	245.11	318.1
251	848.8	246.97	319.1

**PCS Band (Part 24E) result**

Channel	Frequency (MHz)	99% Occupied Bandwidth (kHz)	26 dB Bandwidth (kHz)
512	1850	246.89	316.5
661	1880	246.73	316.5
810	1910	243.75	317.5

**GPRS:**

**Cellular Band (Part 22H) result**

Channel	Frequency (MHz)	99% Occupied Bandwidth (kHz)	26 dB Bandwidth (kHz)
128	824.2	247.81	321.9
190	836.6	244.63	315.6
251	848.8	244.54	318.5

**PCS Band (Part 24E) result**

Channel	Frequency (MHz)	99% Occupied Bandwidth (kHz)	26 dB Bandwidth (kHz)
512	1850	245.24	315.9
661	1880	245.06	314.7
810	1910	245.60	315.7

**EGPRS (MCS 5):**

**Cellular Band (Part 22H) result**

Channel	Frequency (MHz)	99% Occupied Bandwidth (kHz)	26 dB Bandwidth (kHz)
128	824.2	247.26	318.6
190	836.6	244.48	318.7
251	848.8	243.72	317.9

**PCS Band (Part 24E) result**

Channel	Frequency (MHz)	99% Occupied Bandwidth (kHz)	26 dB Bandwidth (kHz)
512	1850	245.85	317.1
661	1880	244.99	315.5
810	1910	247.12	314.9

**RMC:**

**UMTS-FDD Band V (Part 22H)**

Channel	Frequency (MHz)	99% Occupied Bandwidth (MHz)	26 dB Bandwidth (MHz)
4132	826.6	4.1811	4.819
4175	835.0	4.2243	4.846
4233	846.4	4.1893	4.823

**UMTS-FDD Band II (Part 24E)**

Channel	Frequency (MHz)	99% Occupied Bandwidth (MHz)	26 dB Bandwidth (MHz)
9262	1853	4.2008	4.865
9400	1880	4.2117	4.862
9538	1907	4.2238	4.882

**HSDPA:**

**UMTS-FDD Band V (Part 22H)**

Channel	Frequency (MHz)	99% Occupied Bandwidth (MHz)	26 dB Bandwidth (MHz)
4132	826.6	4.1744	4.823
4175	835.0	4.2278	4.836
4233	846.4	4.1916	4.842

**UMTS-FDD Band II (Part 24E)**

Channel	Frequency (MHz)	99% Occupied Bandwidth (MHz)	26 dB Bandwidth (MHz)
9262	1853	4.2070	4.820
9400	1880	4.2079	4.879
9538	1907	4.2143	4.884

**HSUPA:**

**UMTS-FDD Band V (Part 22H)**

Channel	Frequency (MHz)	99% Occupied Bandwidth (MHz)	26 dB Bandwidth (MHz)
4132	826.6	4.1754	4.846
4175	835.0	4.2189	4.896
4233	846.4	4.2014	4.827

**UMTS-FDD Band II (Part 24E)**

Channel	Frequency (MHz)	99% Occupied Bandwidth (MHz)	26 dB Bandwidth (MHz)
9262	1853	4.2018	4.838
9400	1880	4.2014	4.861
9538	1907	4.2358	4.887

### Test Plots

#### GSM Voice:

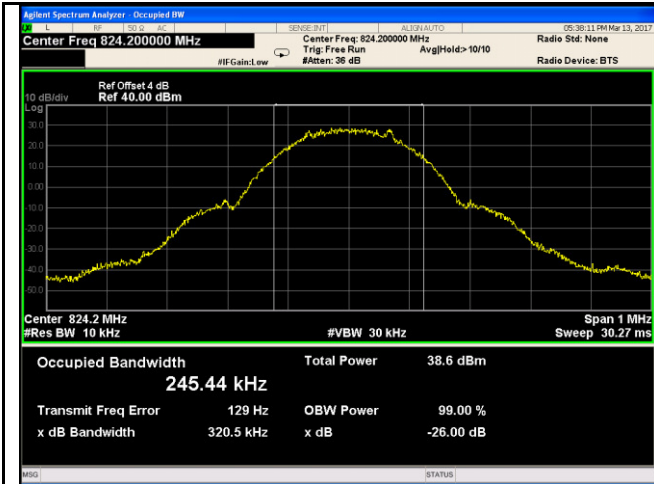

GSM 850 BW - Low CH 824.2MHz

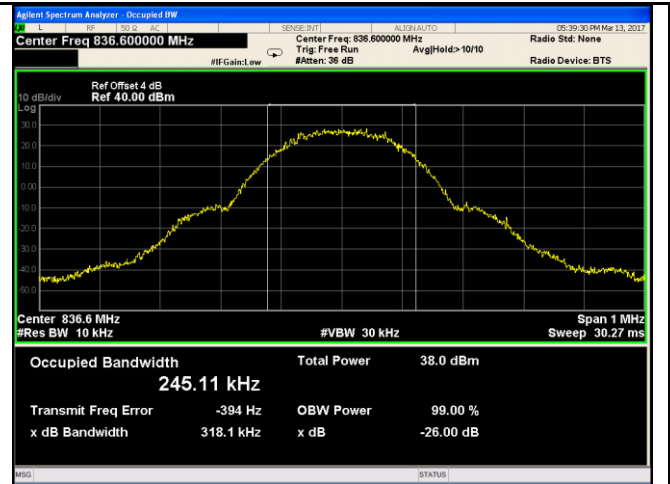

GSM 850 BW - Mid CH 836.6MHz

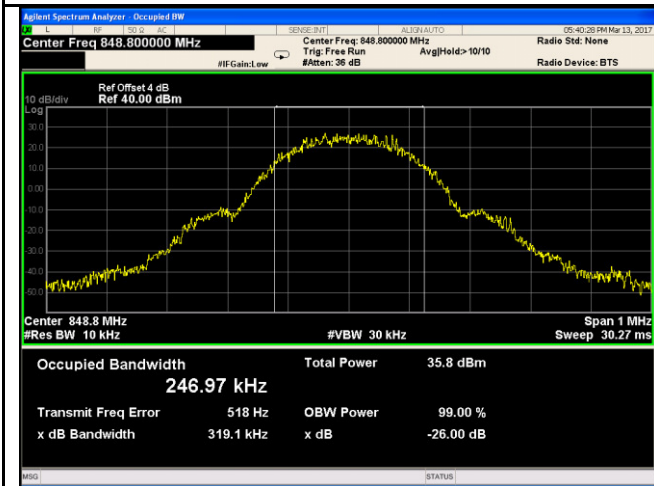

GSM 850 BW - High CH 848.8MHz

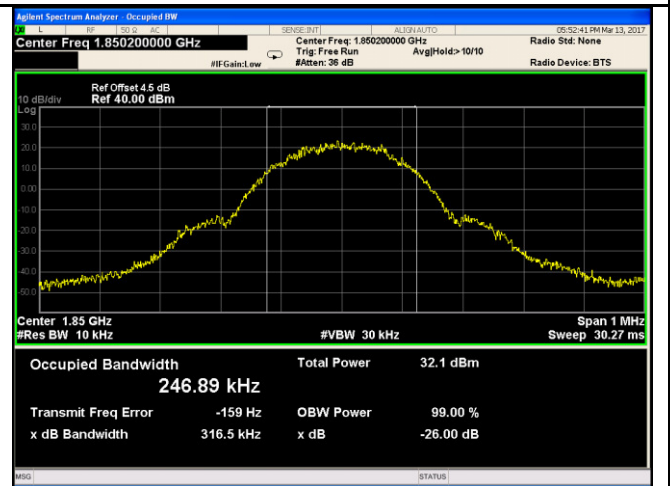

PCS 1900 BW - Low CH 1850.2MHz

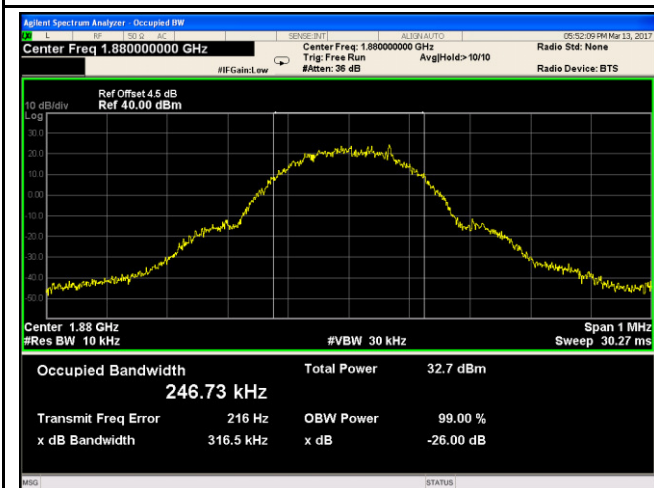

PCS 1900 BW - Mid CH 1880MHz

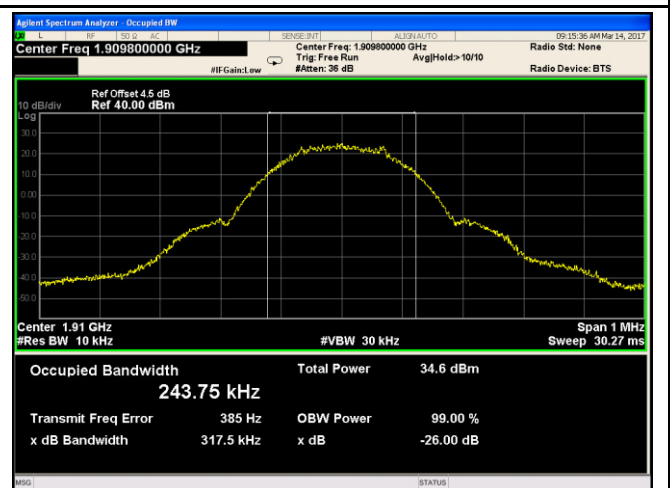

PCS 1900 BW - High CH 1909.8MHz



**GPRS:**

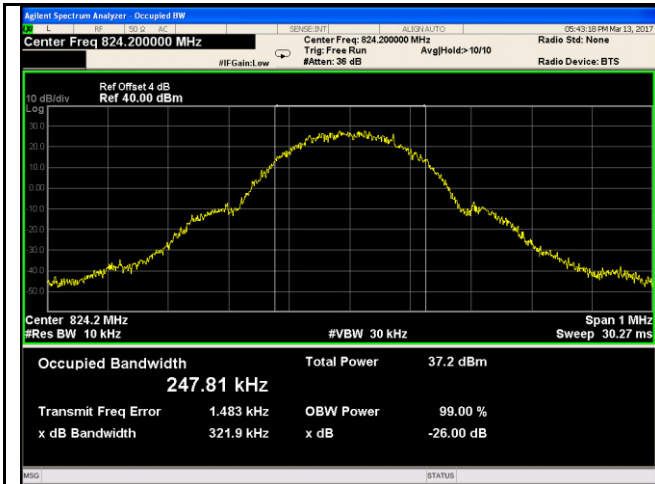

GSM 850 BW - Low CH 824.2MHz

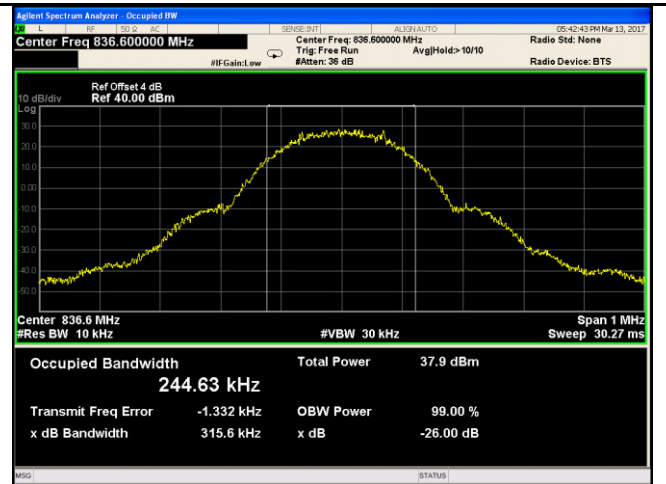

GSM 850 BW - Mid CH 836.6MHz

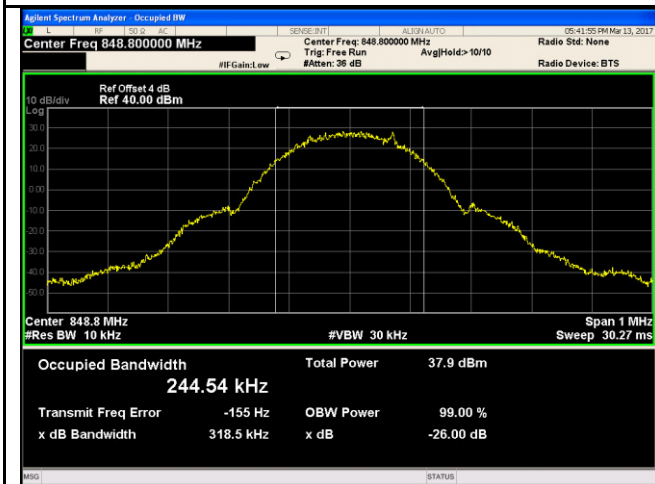

GSM 850 BW - High CH 848.8MHz

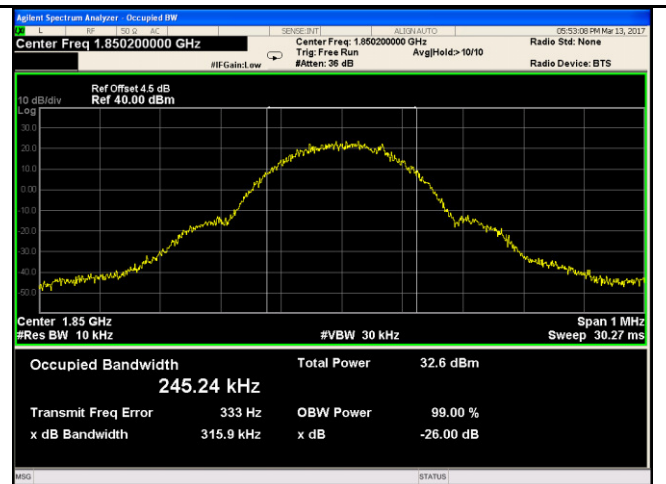

PCS 1900 BW - Low CH 1850.2MHz

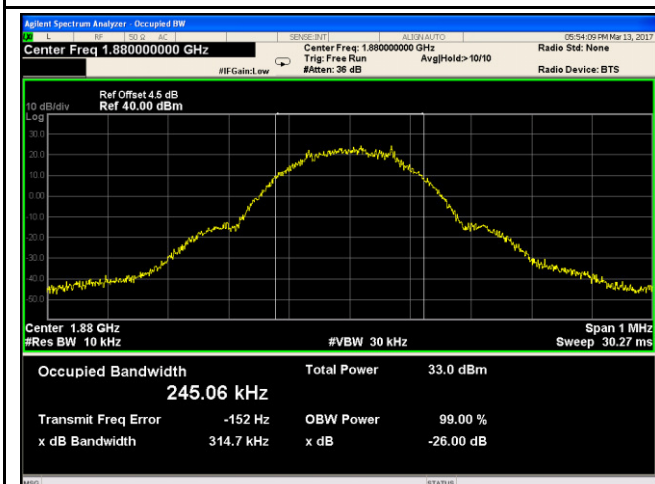

PCS 1900 BW - Mid CH 1880MHz

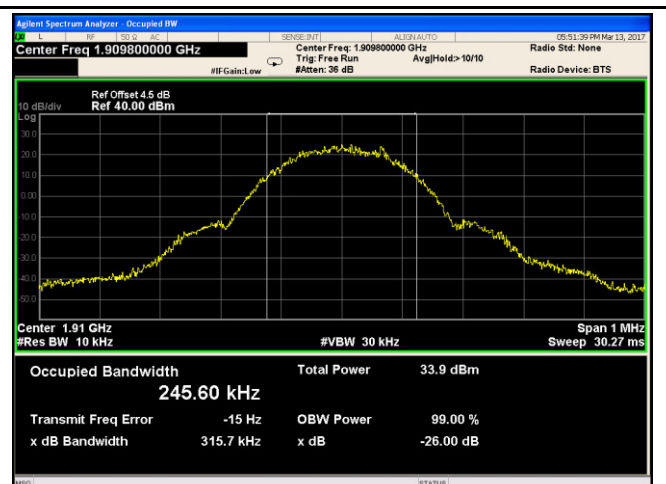

PCS 1900 BW - High CH 1909.8MHz

**EGPRS (MCS5):**

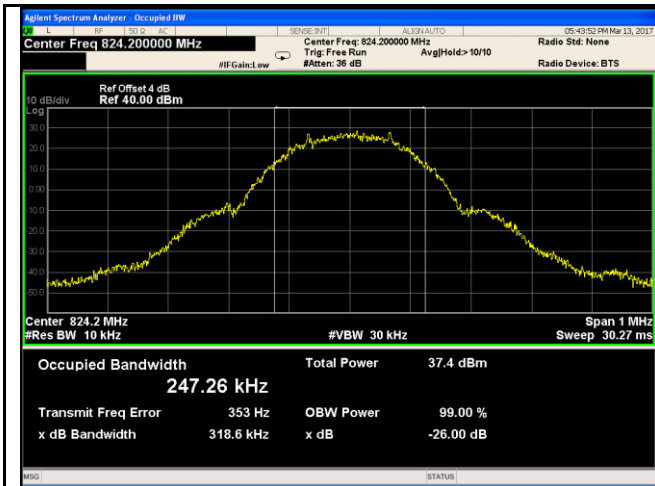

GSM 850 BW - Low CH 824.2MHz

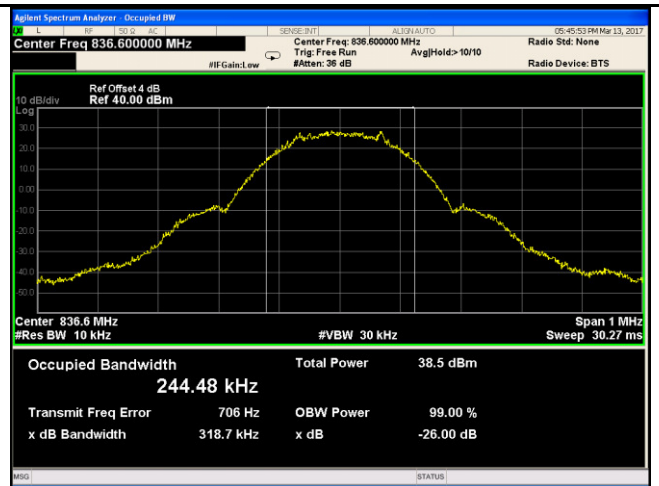

GSM 850 BW - Mid CH 836.6MHz

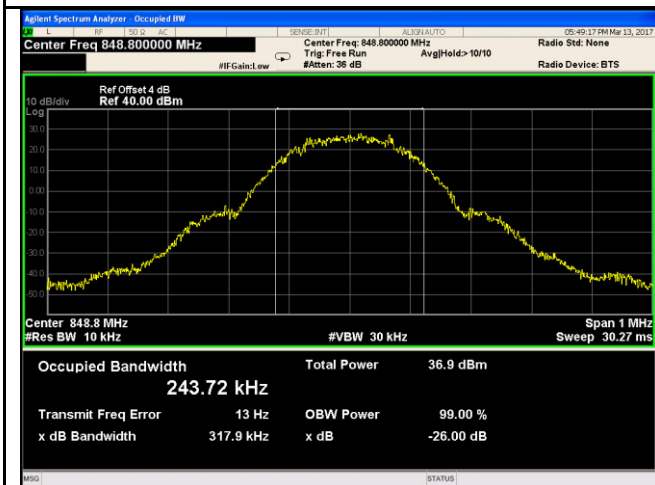

GSM 850 BW - High CH 848.8MHz

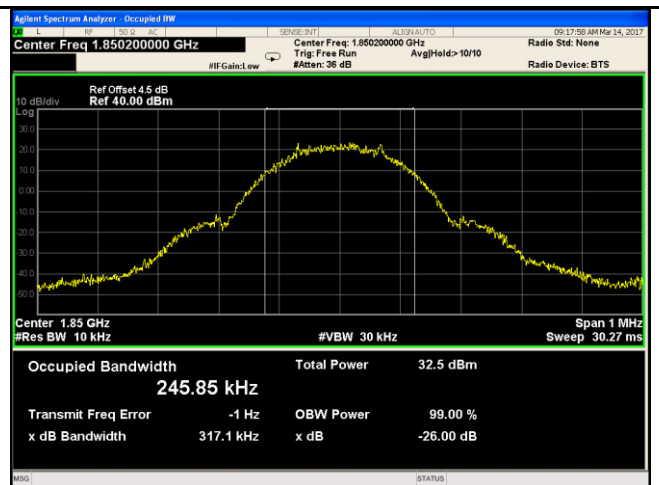

PCS 1900 BW - Low CH 1850.2MHz

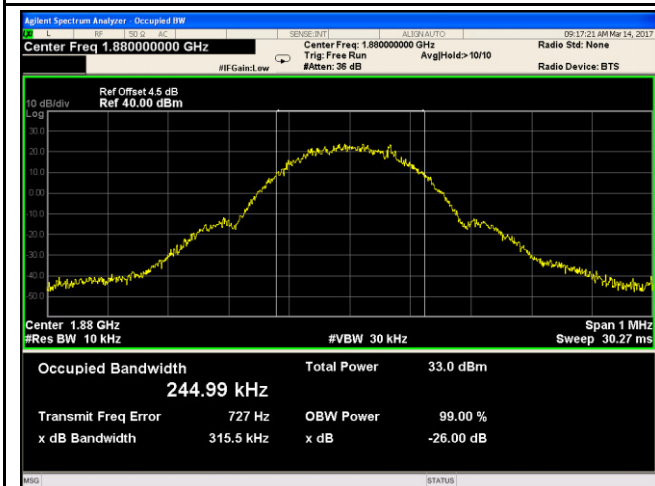

PCS 1900 BW - Mid CH 1880MHz

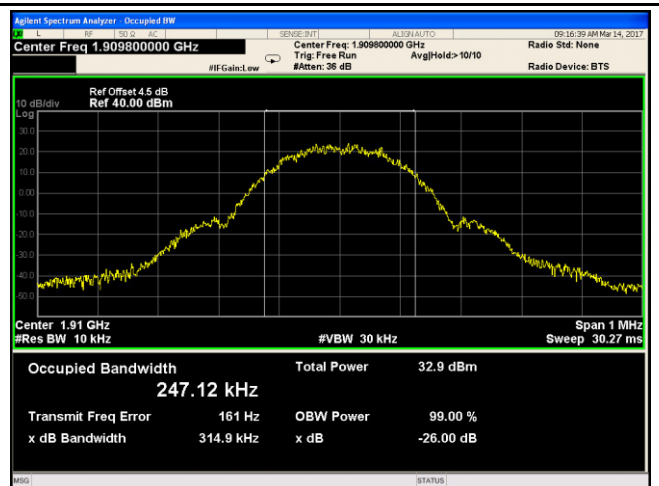

PCS 1900 BW - High CH 1909.8MHz

RMC:

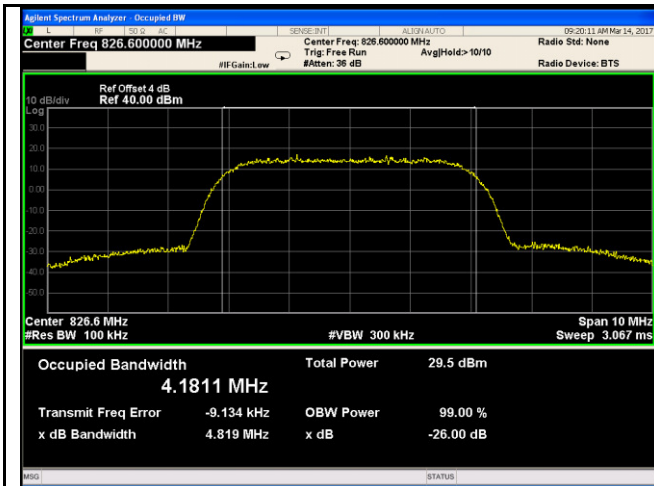

Band V BW - Low CH 826.6 MHz

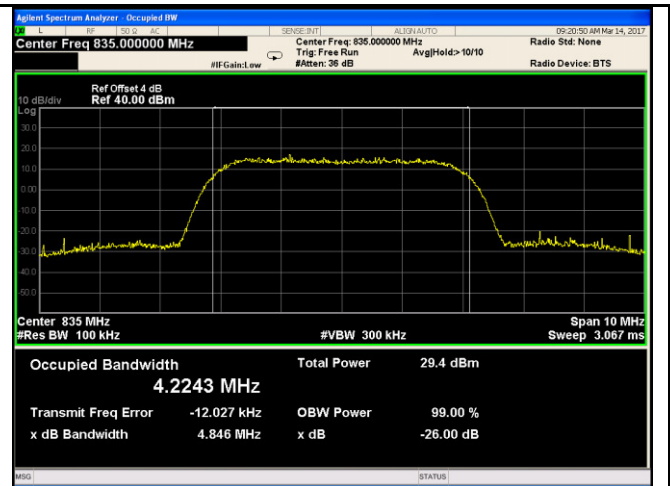

Band V BW - Mid CH 835.0 MHz

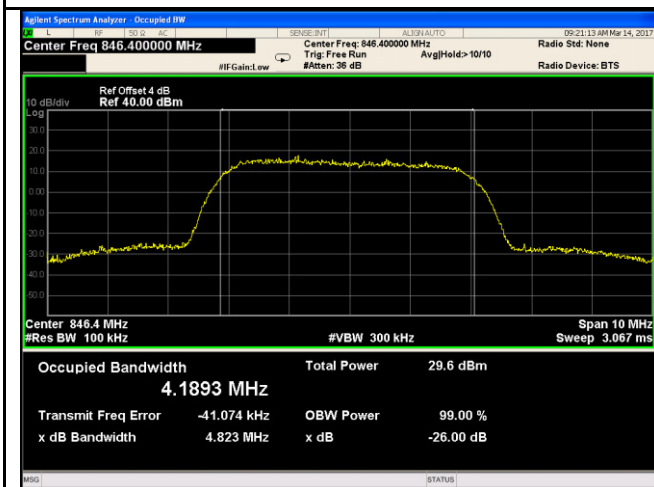

Band V BW - High CH 846.4 MHz

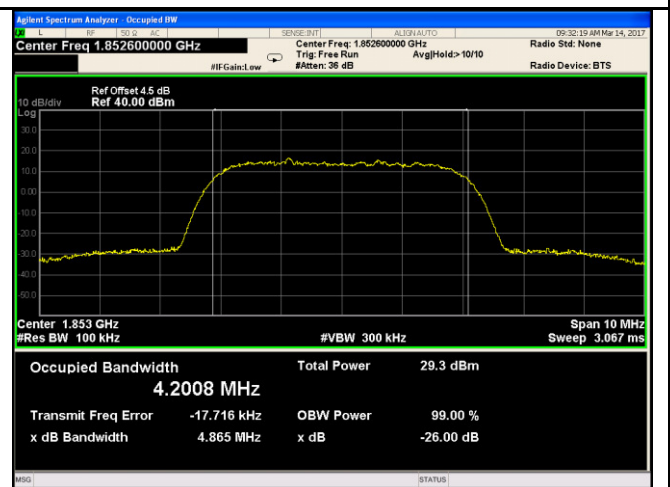

Band II BW - Low CH 1852.4MHz

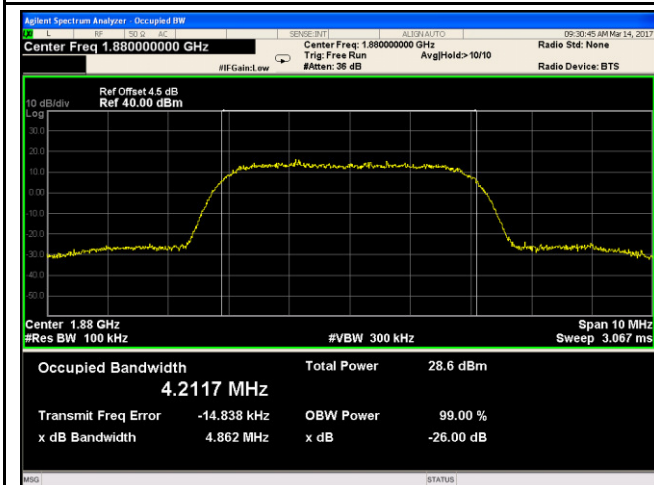

Band II BW - Mid CH 1880MHz

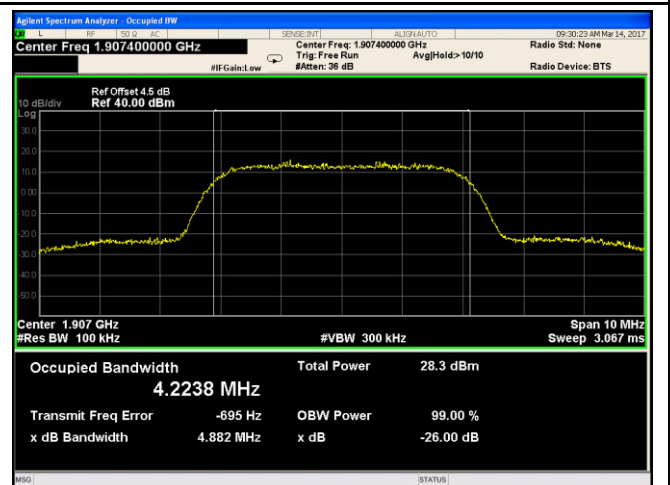

Band II BW - High CH 1907.6MHz

HSDPA:

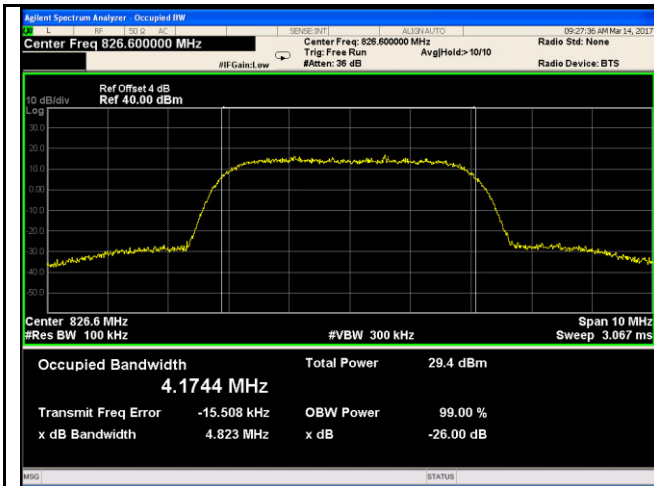

Band V BW - Low CH 826.6 MHz

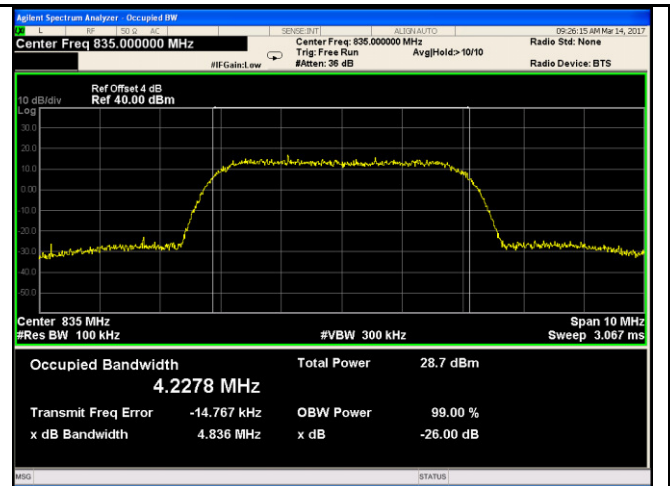

Band V BW - Mid CH 835.0 MHz

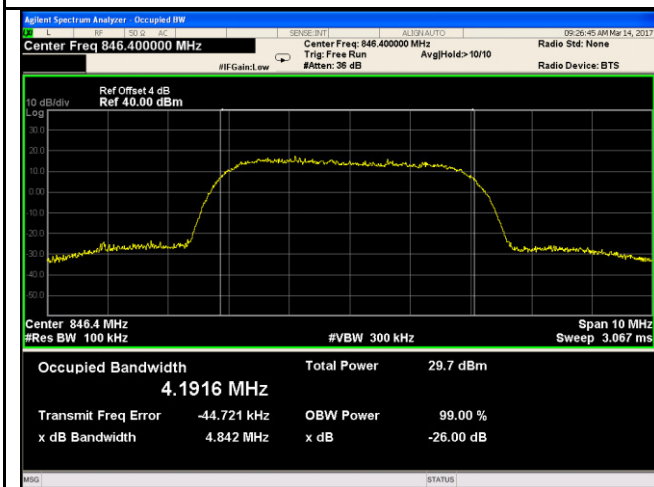

Band V BW - High CH 846.4 MHz

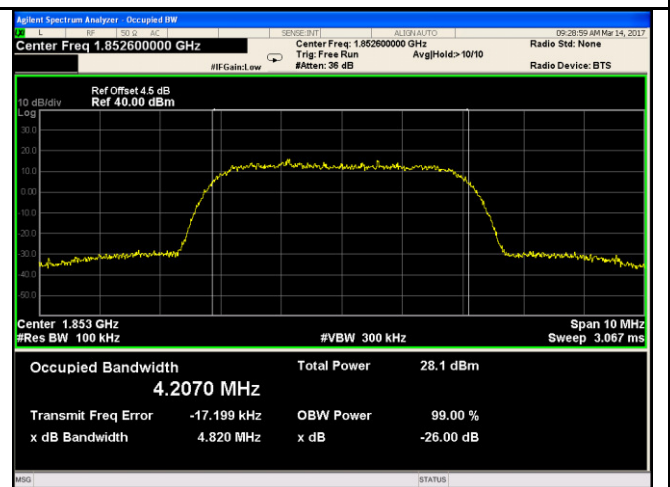

Band II BW - Low CH 1852.4 MHz

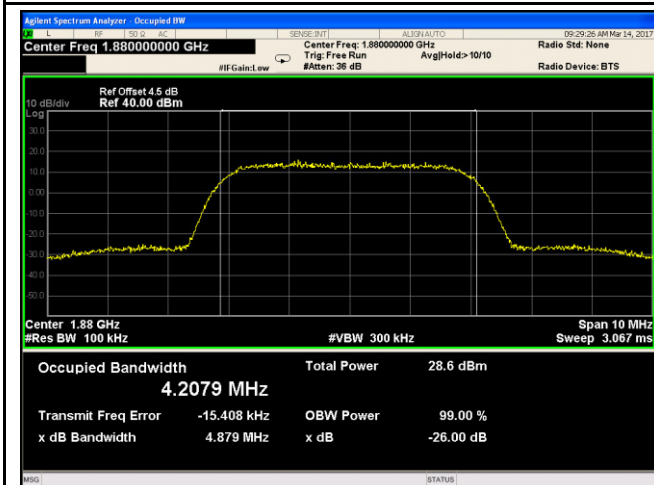

Band II BW - Mid CH 1880 MHz

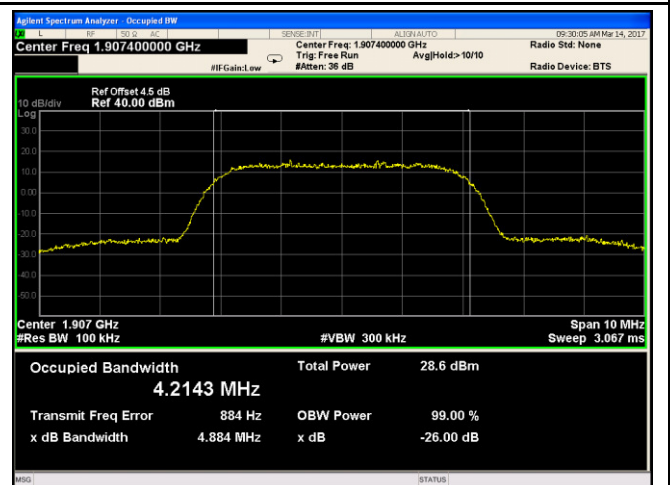

Band II BW - High CH 1907.6 MHz

HSUPA:

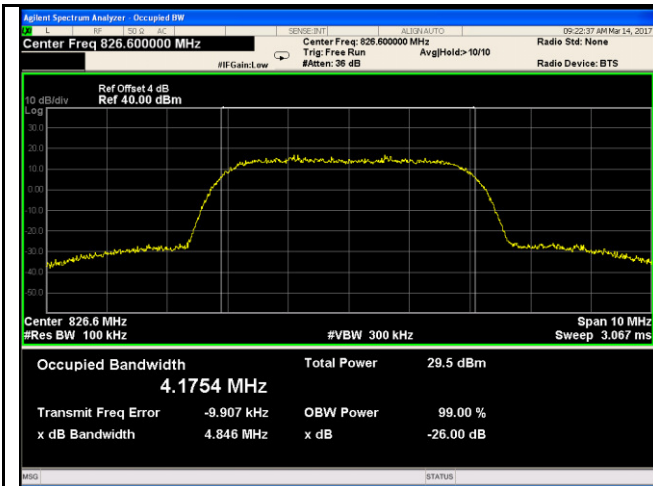

Band V BW - Low CH 826.6 MHz

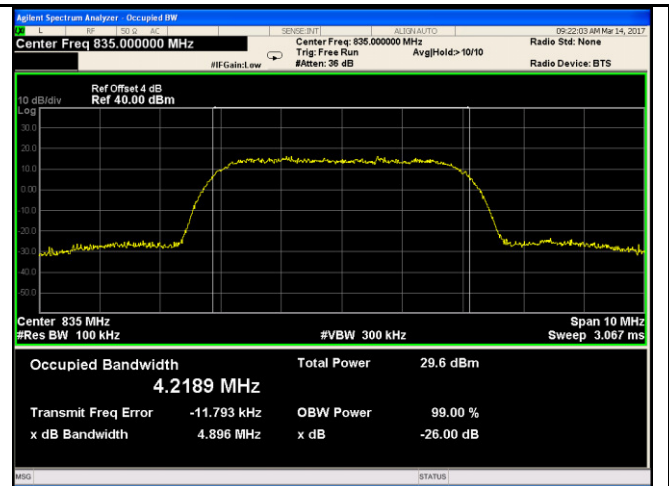

Band V BW - Mid CH 835.0 MHz

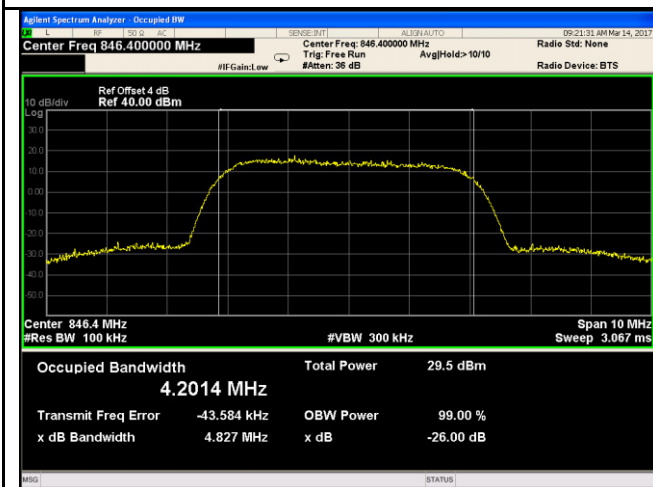

Band V BW - High CH 846.4 MHz

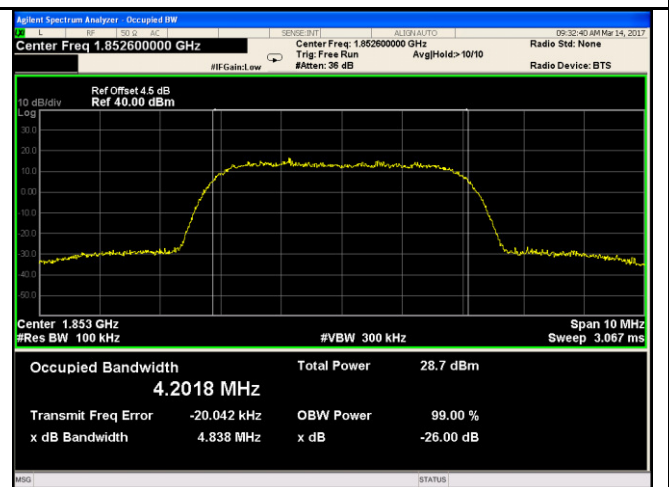

Band II BW - Low CH 1852.4 MHz

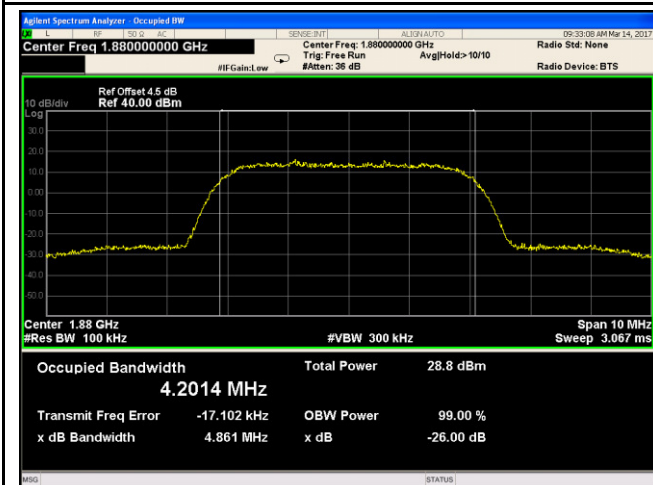

Band II BW - Mid CH 1880 MHz

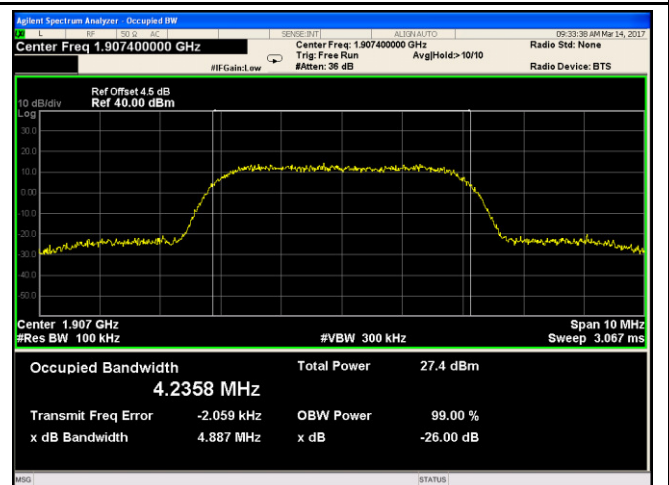

Band II BW - High CH 1907.6 MHz

## 6.5 Spurious Emissions at Antenna Terminals

Temperature	22°C
Relative Humidity	55%
Atmospheric Pressure	1012mbar
Test date :	March 14, 2017
Tested By :	Loren Luo

### Requirement(s):

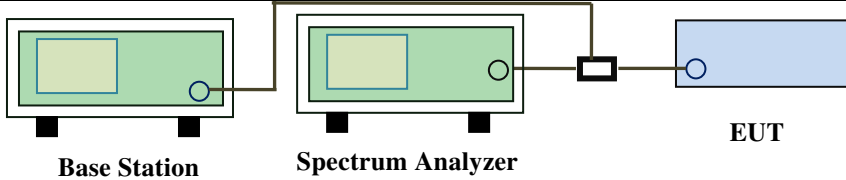
Spec	Item	Requirement	Applicable
§2.1051, §22.917(a)& §24.238(a)	a)	The power of any emission outside of the authorized operating frequency ranges must be lower than the transmitter power (P) by a factor of at least $43 + 10 \log(P)$ dB	<input checked="" type="checkbox"/>
Test Setup	 <p style="text-align: center;">Base Station      Spectrum Analyzer      EUT</p>		
Test Procedure	<ul style="list-style-type: none"> <li>- The EUT was connected to Spectrum Analyzer and Base Station via power divider.</li> <li>- The Band Edges of low and high channels for the highest RF powers were measured.</li> <li>- Setting RBW as roughly BW/100.</li> </ul>		
Remark			
Result	<input checked="" type="checkbox"/> Pass <input type="checkbox"/> Fail		

Test Data     Yes       N/A  
 Test Plot     Yes (See below)       N/A

Test Plots

GSM Voice:

Cellular Band (Part 22H) result

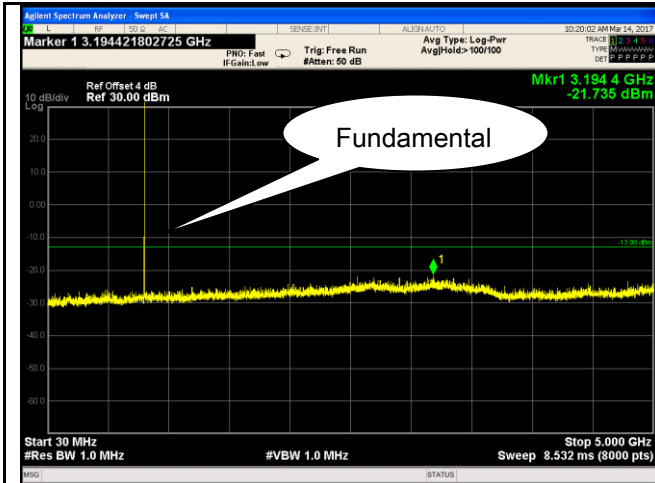

GSM 850 - Low Channel-1

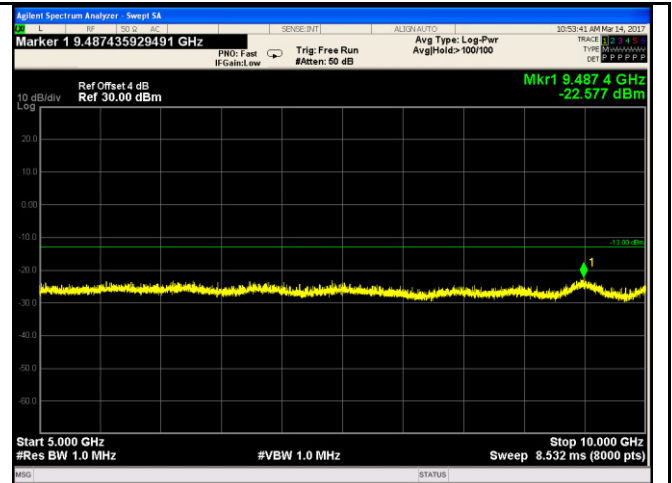

GSM 850 - Low Channel-2

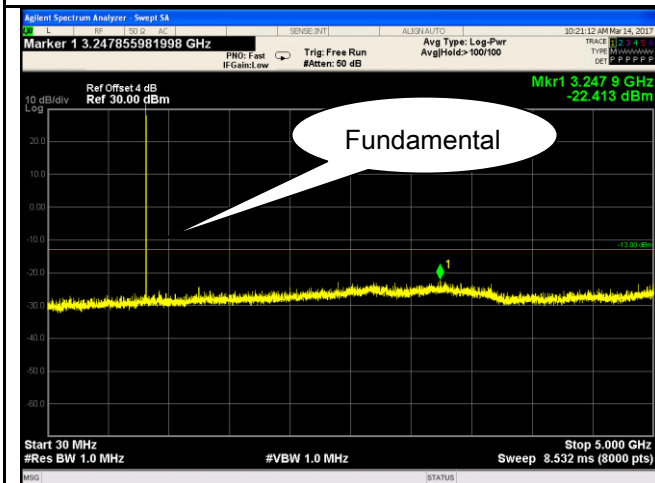

GSM 850 Middle Channel-1

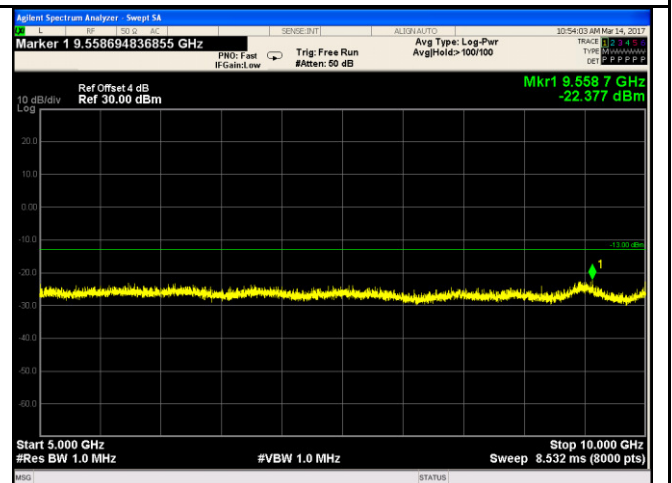

GSM 850 Middle Channel-2

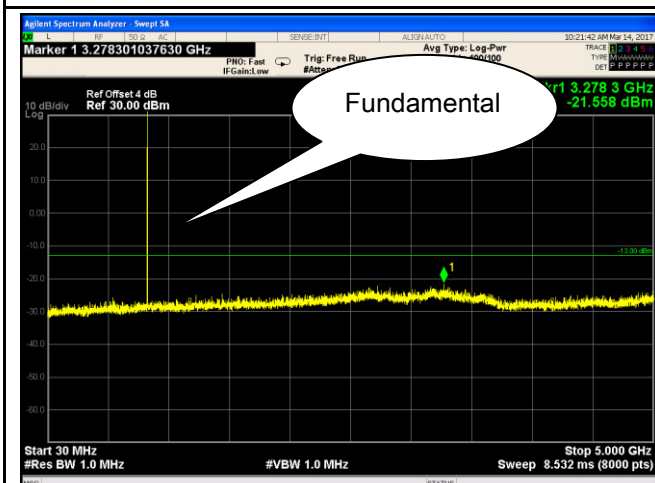

GSM 850 - High Channel-1

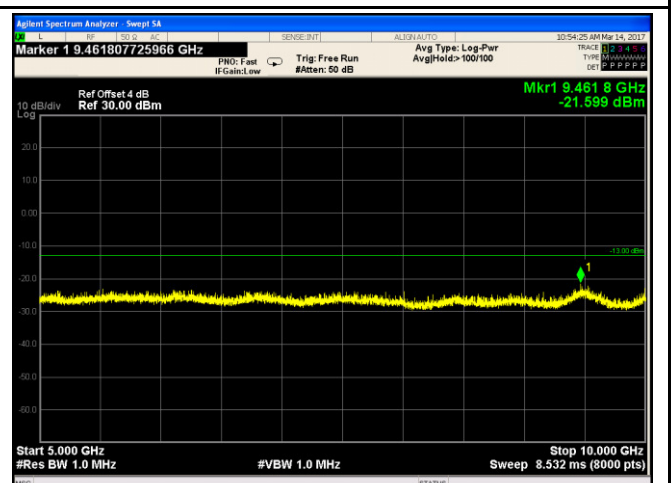

GSM 850 - High Channel-2

### PCS Band (Part24E) result

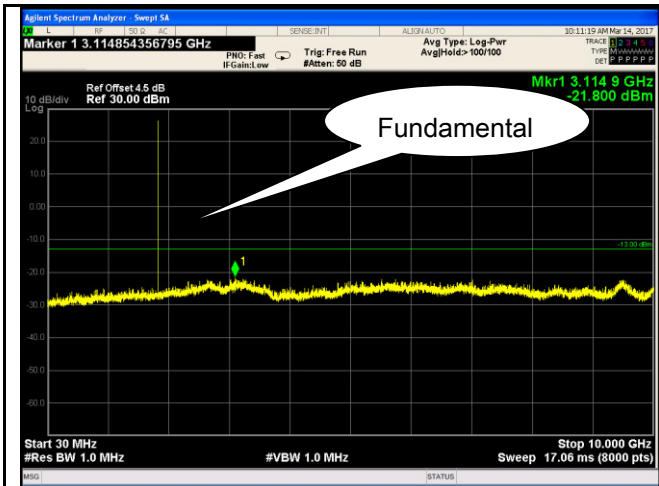

PCS1900 - Low Channel-1

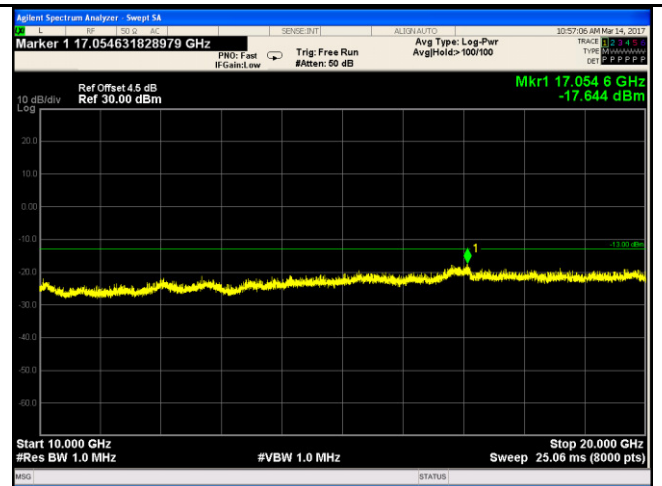

PCS 1900 - Low Channel-2

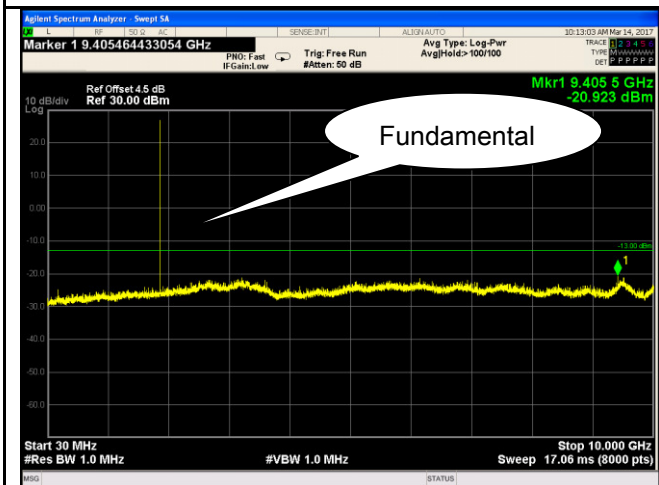

PCS1900 - Middle Channel-1

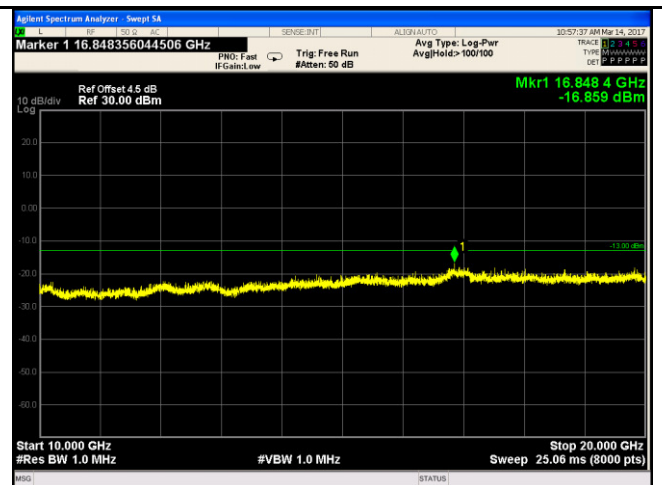

PCS 1900 - Middle Channel-2

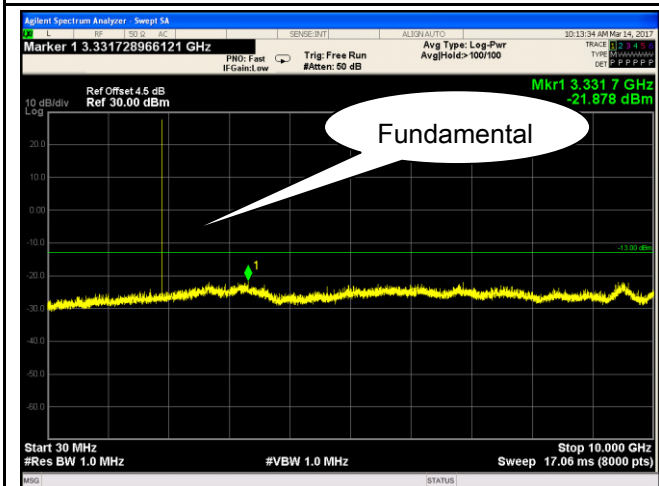

PCS1900 - High Channel-1

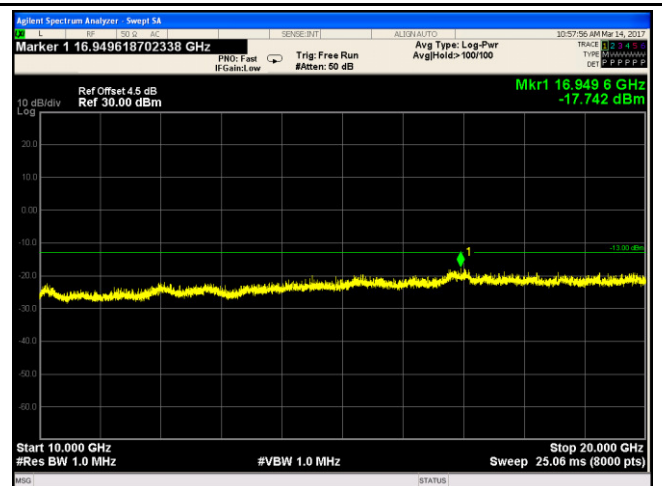

PCS 1900 - High Channel-2



GPRS:

Cellular Band (Part 22H) result

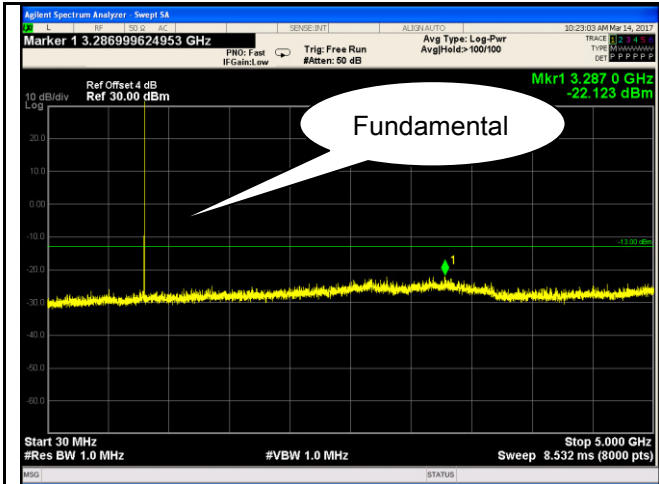

GSM 850 - Low Channel-1

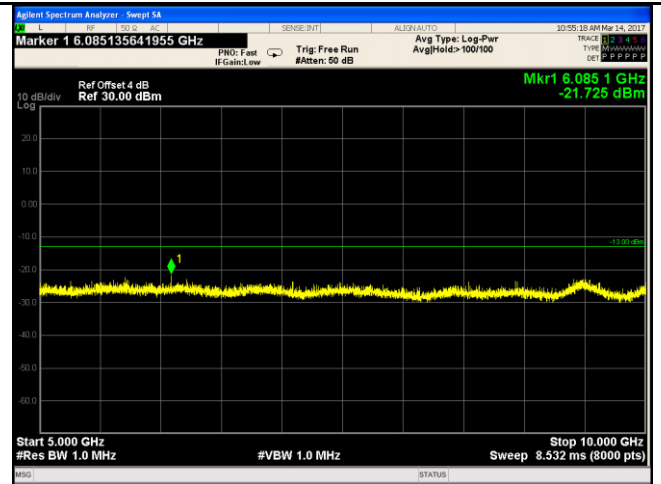

GSM 850 - Low Channel-2

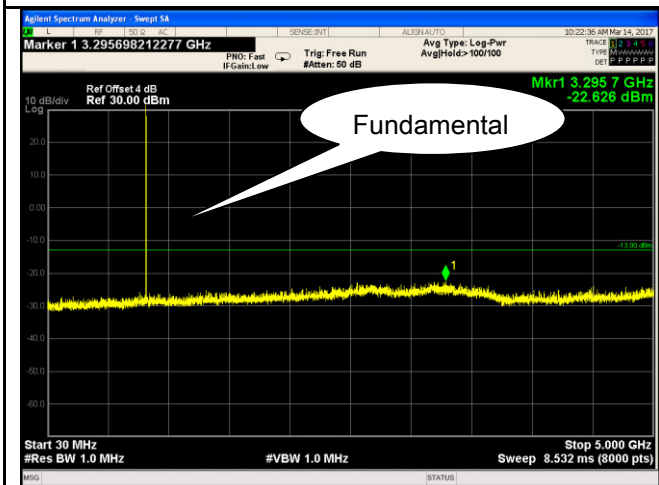

GSM 850 Middle Channel-1

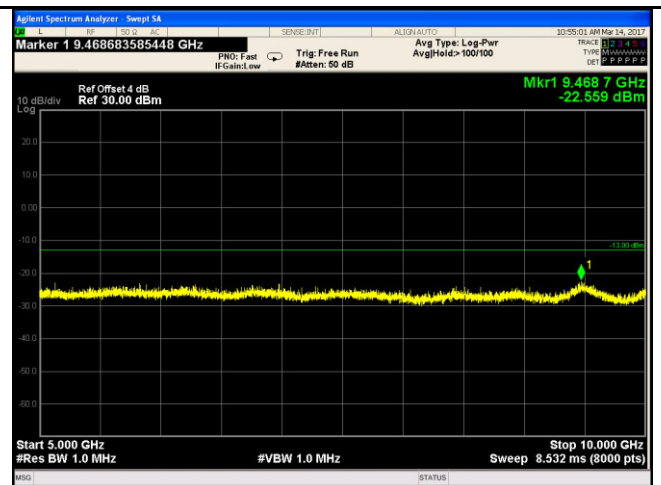

GSM 850 Middle Channel-2

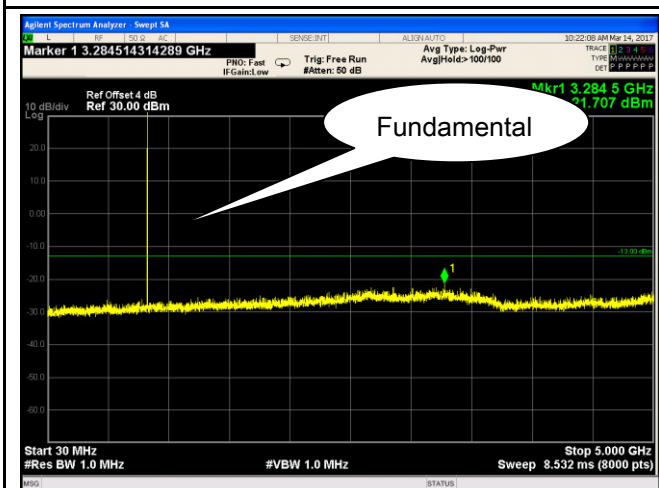

GSM 850 - High Channel-1

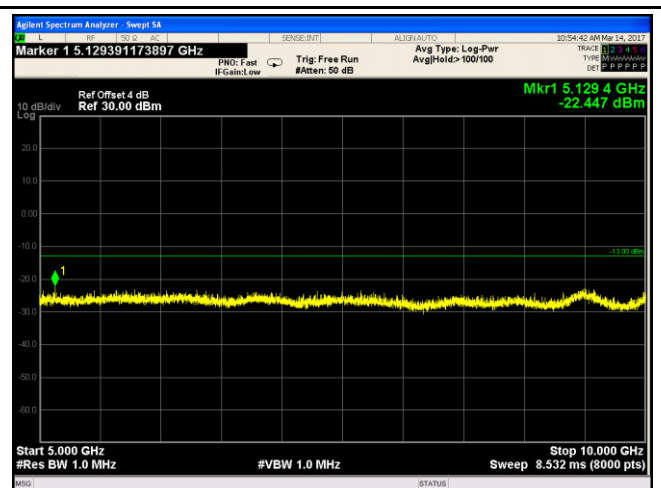

GSM 850 - High Channel-2

PCS Band (Part24E) result

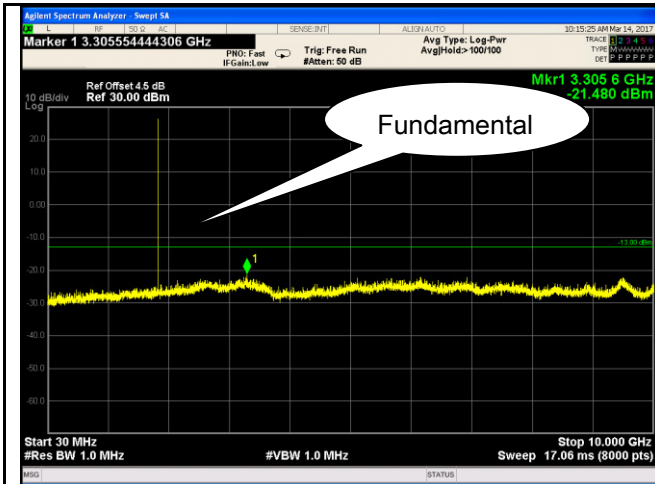

PCS1900 - Low Channel-1

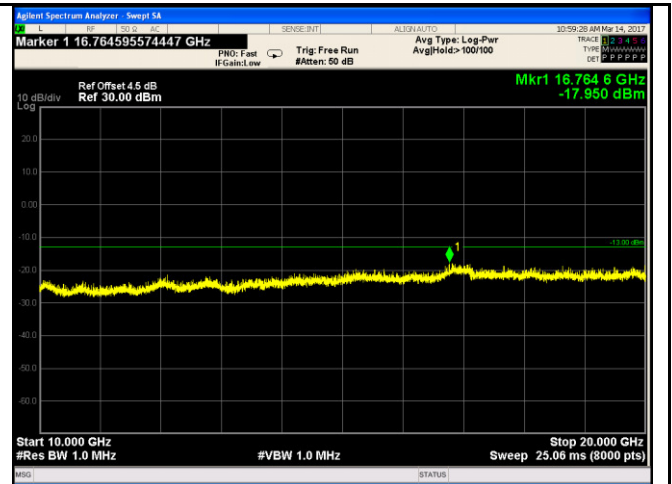

PCS 1900 - Low Channel-2

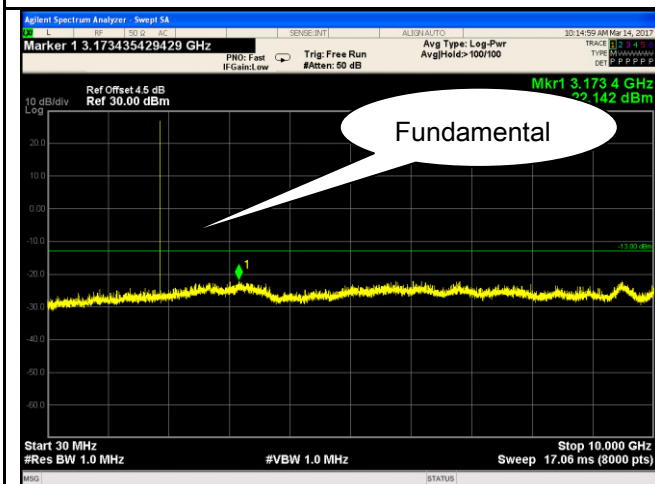

PCS1900 - Middle Channel-1

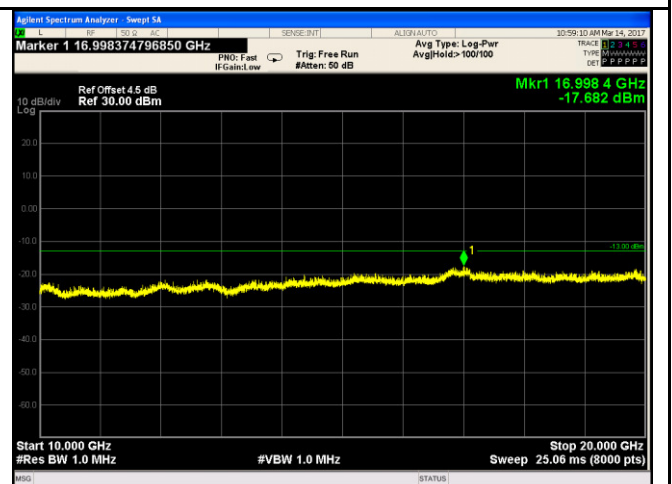

PCS 1900 - Middle Channel-2

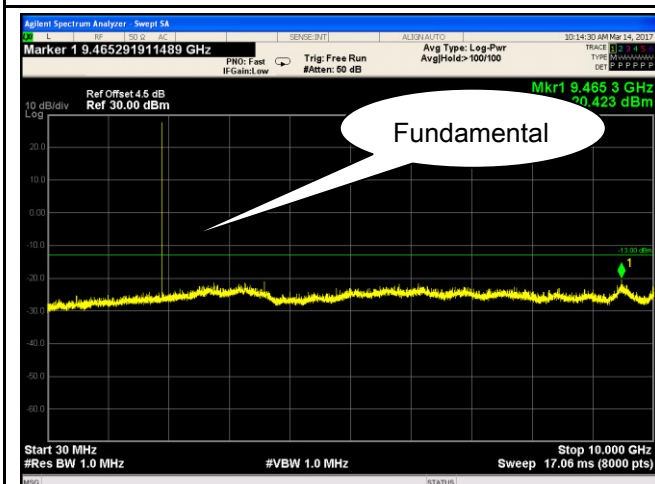

PCS1900 - High Channel-1

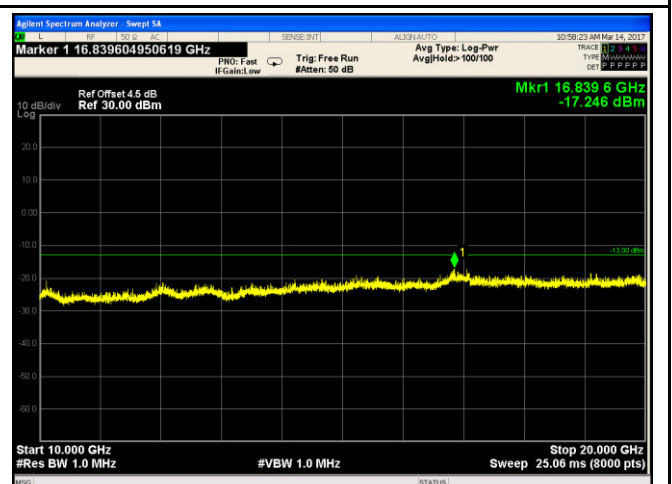

PCS 1900 - High Channel-2

EGPRS (MCS 5):  
Cellular Band (Part 22H) result

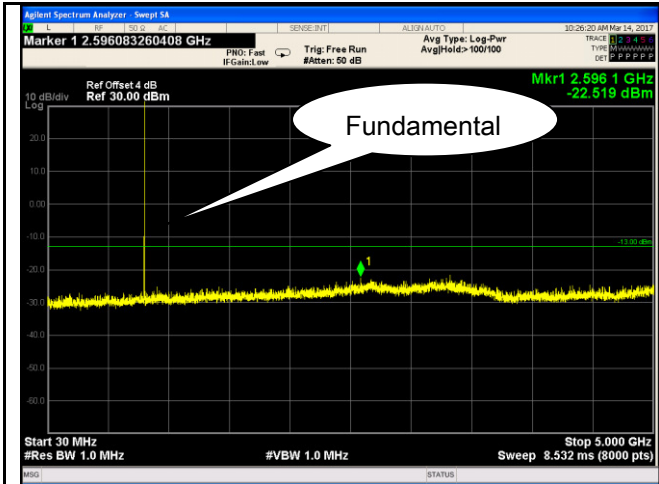

GSM 850 - Low Channel-1

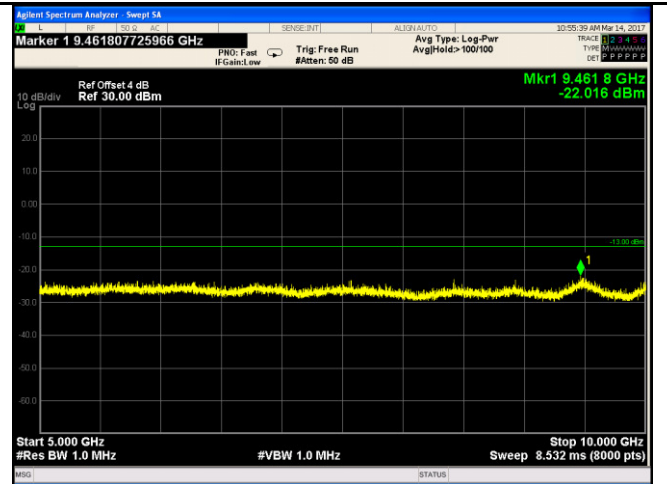

GSM 850 - Low Channel-2

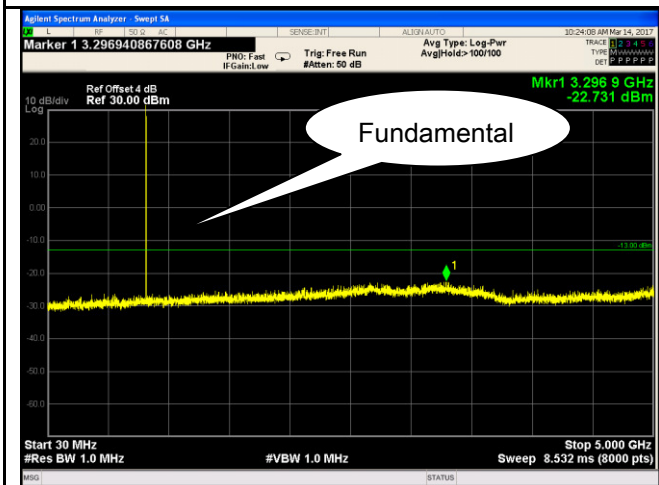

GSM 850 Middle Channel-1

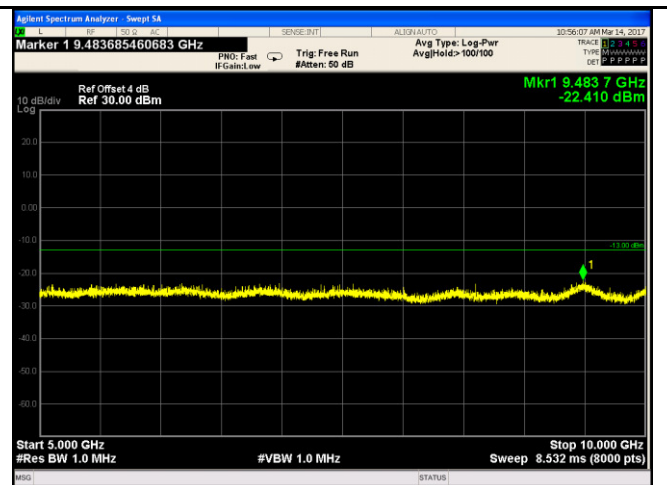

GSM 850 Middle Channel-2

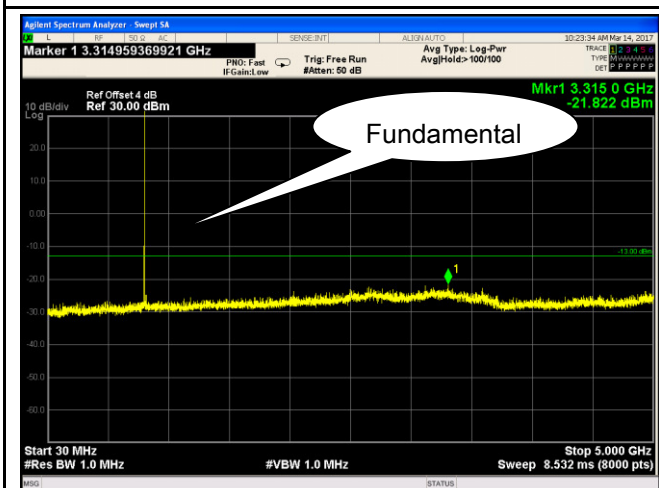

GSM 850 - High Channel-1

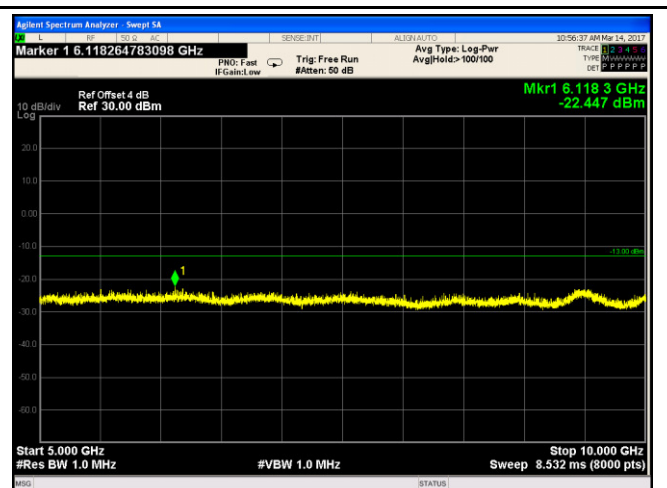

GSM 850 - High Channel-2

PCS Band (Part24E) result

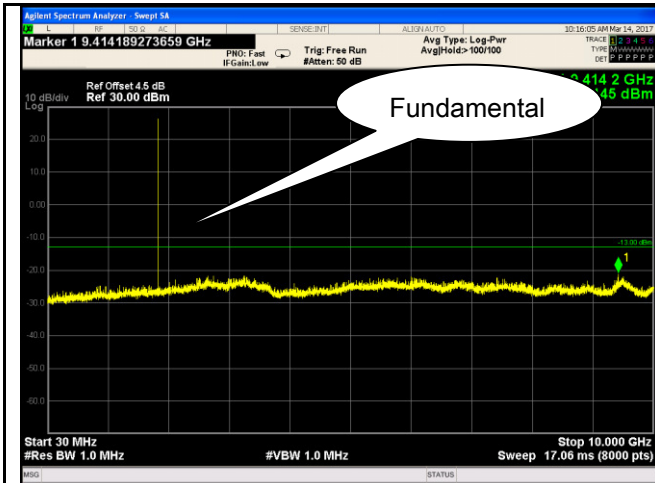

PCS1900 - Low Channel-1

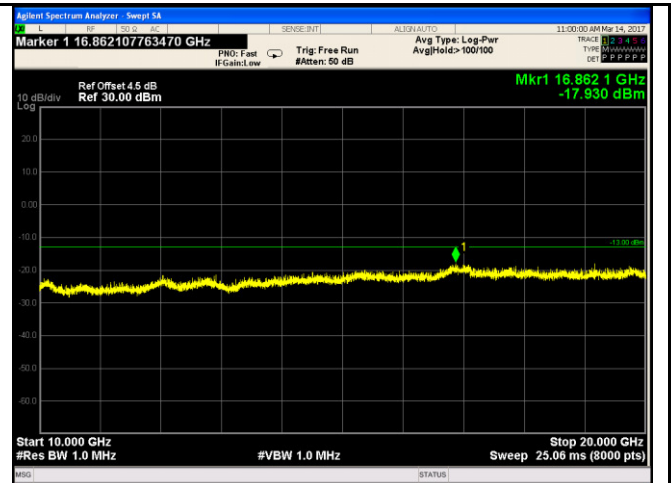

PCS 1900 - Low Channel-2

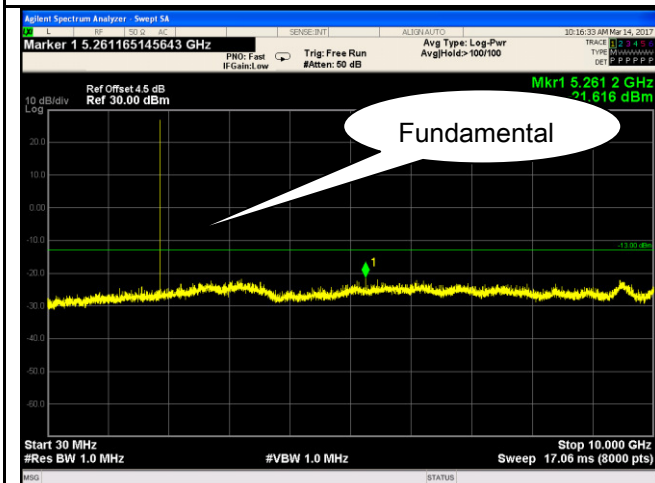

PCS1900 - Middle Channel-1

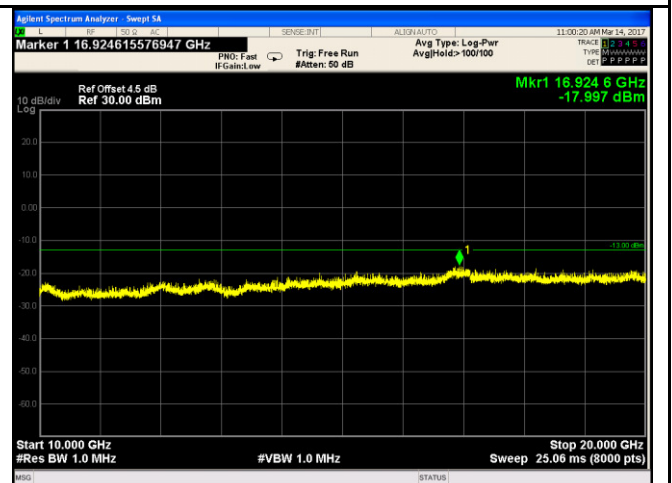

PCS 1900 - Middle Channel-2

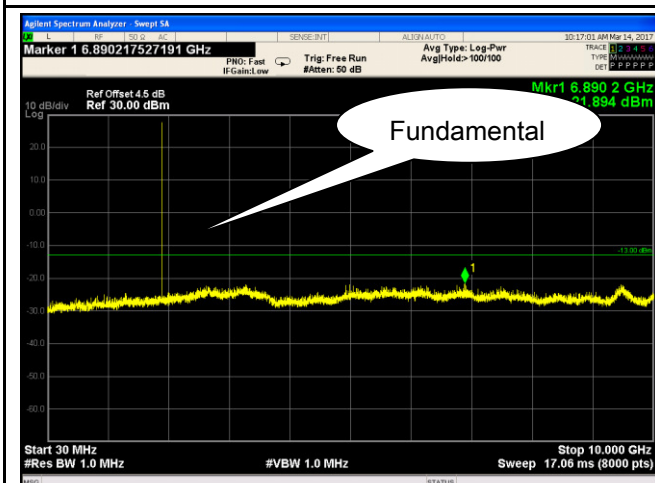

PCS1900 - High Channel-1

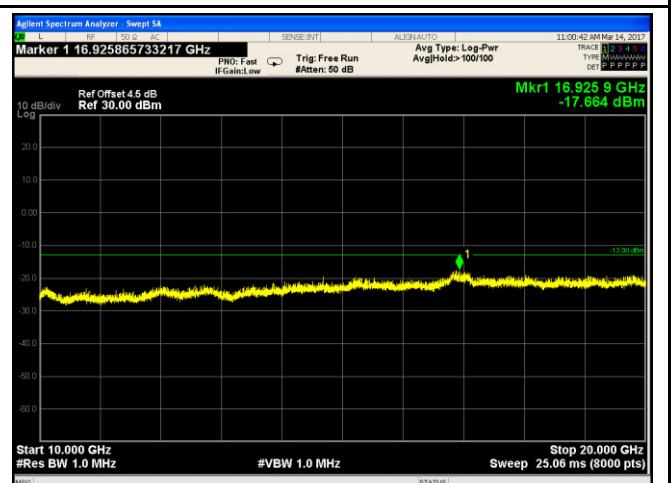

PCS 1900 - High Channel-2

RMC

UMTS-FDD Band V (Part 22H)

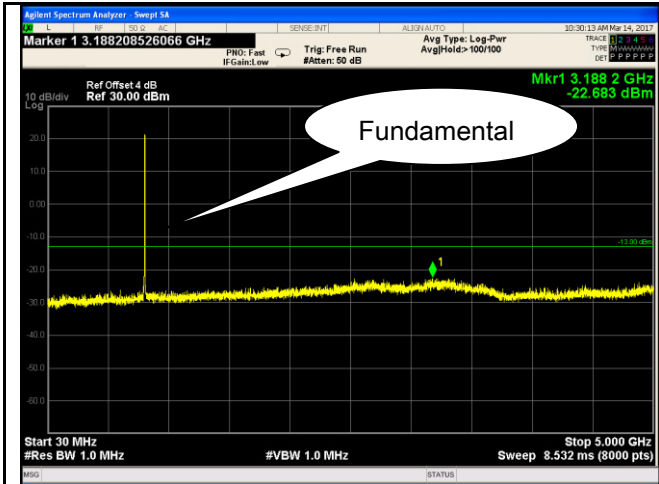

Band V - Low Channel-1

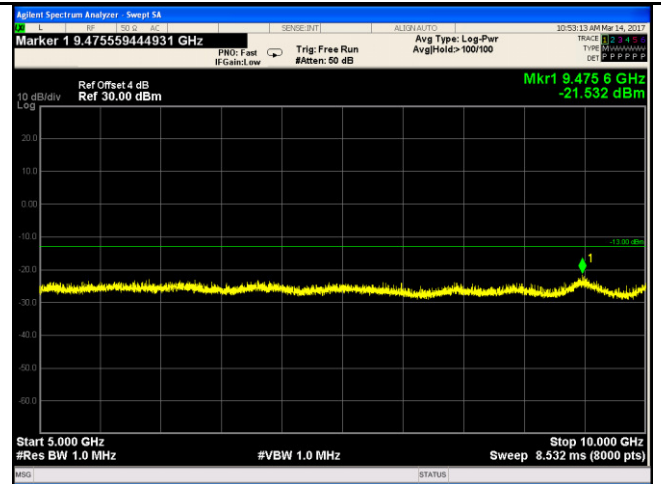

Band V - Low Channel-2

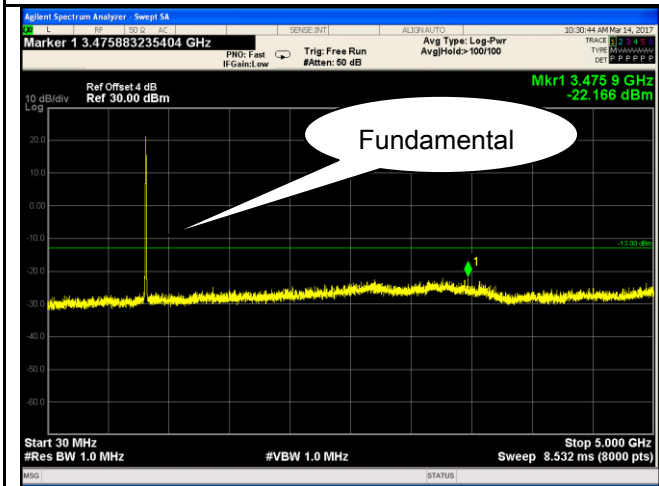

Band V - Middle Channel-1

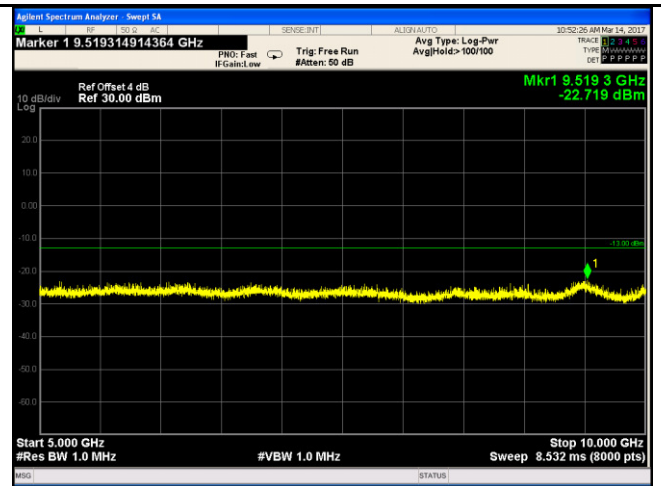

Band V - Middle Channel-2

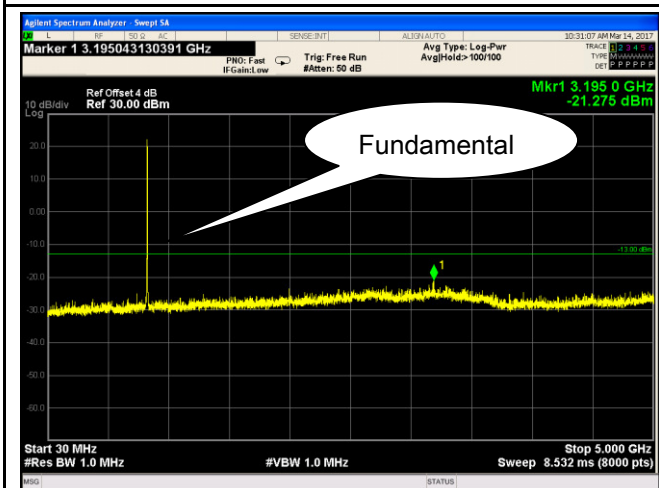

Band V - High Channel-1

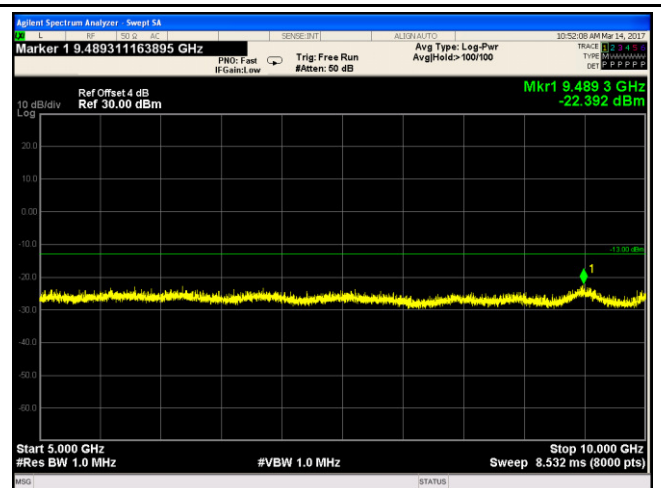

Band V - High Channel-2

### UMTS-FDD Band II (Part 24E)

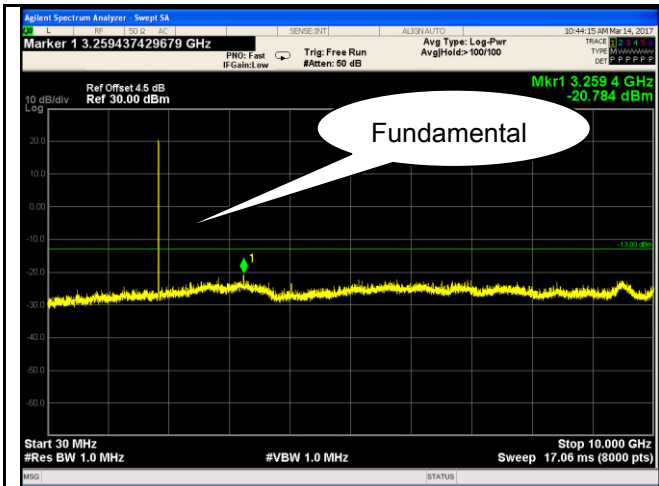

Band II - Low Channel-1

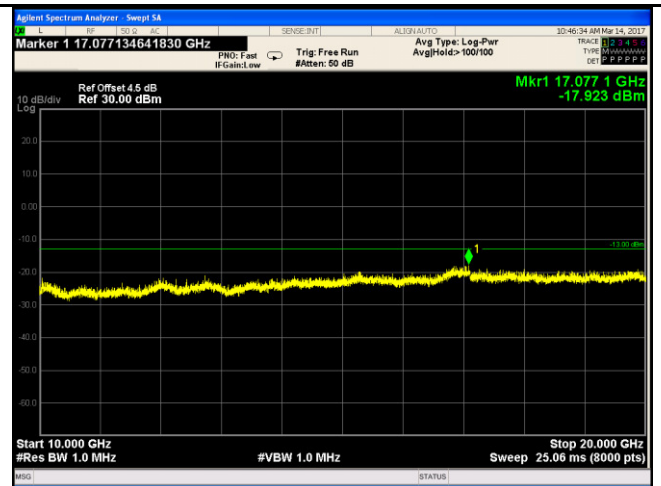

Band II - Low Channel-2

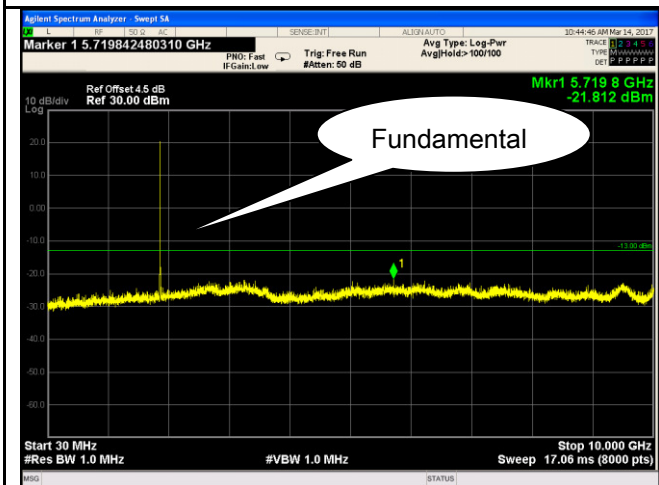

Band II - Middle Channel-1

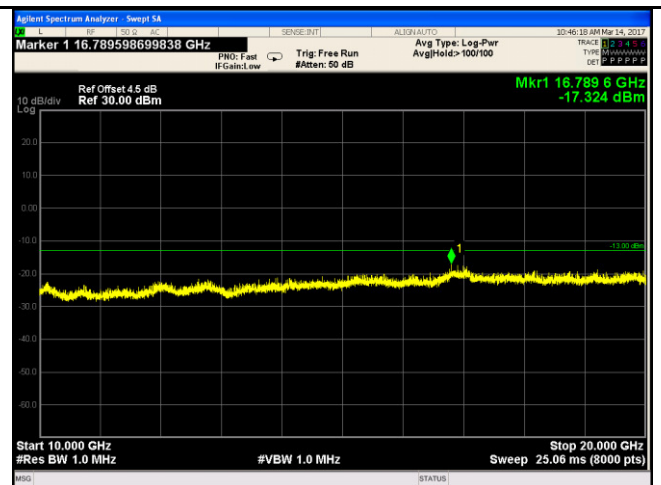

Band II - Middle Channel-2

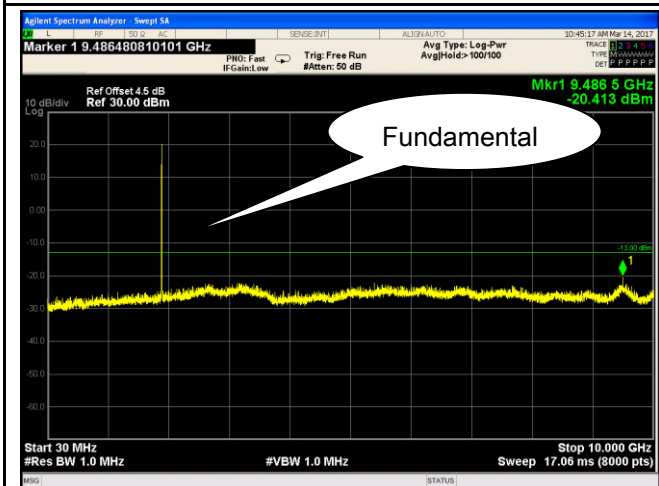

Band II - High Channel-1

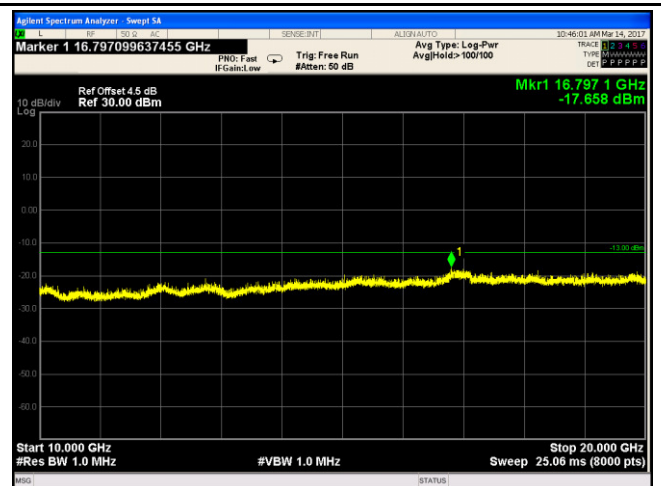

Band II - High Channel-2