



Shenzhen GTI Technology Co., Ltd.

1F,2 Block, Jiaquan Building, Guanlan High-tech Park Baoan District,
Shenzhen, Guangdong, China.

Tel: +86-755-27559792

Fax: +86-755-86116468

Report No.: GTI20160197F-2

Page 1 of 63

TEST REPORT

Product Name: Tablet PC

Trademark: /

Model/Type reference: A723G

Listed Model(s): See the page 6

FCC ID.....: 2AEB5-A723

Test Standards: **FCC Part 15.247: Operation within the bands 902-928 MHz, 2400-2483.5 MHz and 5725-5850 MHz**

Applicant: AOC

Address of applicant: 14F-5, NO.258, Liancheng Rd., Zhonghe Dist., New Taipei City, Taiwan

Date of Receipt: Mar. 05, 2016

Date of Test Date.....: Mar. 05, 2016- Mar. 11, 2016

Data of issue.: Mar. 11, 2016

Test result	Pass *
--------------------	---------------

* In the configuration tested, the EUT complied with the standards specified above

GENERAL DESCRIPTION OF EUT	
Equipment:	Tablet PC
Model Name:	A723G
Manufacturer:	Shenzhen KTC Technology Co., Ltd.
Manufacturer Address:	Northern Wuhe Road, Gangtou,Buji, Longgang,Shenzhen, China
Power Rating:	DC 3.7V from 2700mAh by rechargeable battery DC 5.0V from Adapter

Compiled By:

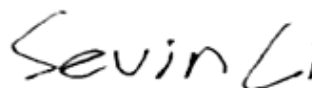

(Sevin Li)

Reviewed By:

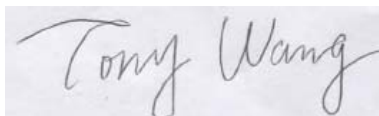

(Tony Wang)

Approved By:

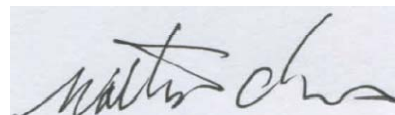

(Walter Chen)

This test report consists of 63 pages in total. It may be duplicated completely for legal use with the approval of the applicant. It should not be reproduced except in full, without the written approval of our laboratory. The client should not use it to claim product endorsement by GTI. The test results in the report only apply to the tested sample. The test report shall be invalid without all the signatures of compiler, reviewer and approver. Any objections must be raised to GTI within 15 days since the date when the report is received. It will not be taken into consideration beyond this limit.



Table of Contents

Page

1. SUMMARY.....	4
1.1. TEST STANDARDS.....	4
1.2. TEST DESCRIPTION.....	4
1.3. TEST FACILITY.....	5
1.4. MEASUREMENT UNCERTAINTY.....	5
2. GENERAL INFORMATION.....	6
2.1. ENVIRONMENTAL CONDITIONS.....	6
2.2. GENERAL DESCRIPTION OF EUT.....	6
2.3. DESCRIPTION OF TEST MODES.....	8
2.1. MEASUREMENT INSTRUMENTS LIST.....	10
3. TEST CONDITIONS AND RESULTS.....	11
3.1. CONDUCTED EMISSION (AC MAIN).....	11
3.2. RADIATED EMISSION.....	20
3.3. MAXIMUM CONDUCTED OUTPUT POWER.....	30
3.4. POWER SPECTRAL DENSITY.....	32
3.5. 6dB BANDWIDTH.....	37
3.6. BAND EDGE COMPLIANCE OF RF EMISSION.....	41
3.7. SPURIOUS RF CONDUCTED EMISSION.....	48
3.8. ANTENNA REQUIREMENT.....	61
4. EUT TEST PHOTO.....	62
5. PHOTOGRAPHS OF EUT CONSTRUCTIONAL.....	63

1. SUMMARY

1.1. Test Standards

The tests were performed according to following standards:

[FCC Rules Part 15.247](#): Frequency Hopping, Direct Spread Spectrum and Hybrid Systems that are in operation within the bands of 902-928 MHz, 2400-2483.5 MHz, and 5725-5850 MHz

[ANSI C63.10-2013](#): American National Standard for Testing Unlicensed Wireless Devices

1.2. Test Description

FCC PART 15 15.247		
FCC Part 15.207	AC Power Conducted Emission	PASS
FCC Part 15.247(a)(2)	6dB Bandwidth	PASS
FCC Part 15.247(d)	Spurious RF Conducted Emission	PASS
FCC Part 15.247(b)	Maximum Peak Output Power	PASS
FCC Part 15.247(e)	Power Spectral Density	PASS
FCC Part 15.205/ 15.209	Radiated Emissions	PASS
FCC Part 15.247(d)	Band Edge	PASS
FCC Part 15.203/15.247 (b)	Antenna Requirement	PASS

1.3. Test Facility

1.3.1 Address of the test laboratory

Shenzhen General Testing & Inspection Technology Co., Ltd.

Add: 1F, 2 Block, Jiaquan Building, Guanlan High-tech Park Baoan District, Shenzhen, Guangdong, China

1.3.2 Laboratory accreditation

The test facility is recognized, certified, or accredited by the following organizations:

IC Registration No.: 9783A

The 3m alternate test site of Shenzhen GTI Technology Co., Ltd. EMC Laboratory has been registered by Certification and Engineer Bureau of Industry Canada for the performance of with Registration NO.: 9783A on Aug, 2011.

FCC-Registration No.: 214666

Shenzhen GTI Technology Co., Ltd. EMC Laboratory has been registered and fully described in a report filed with the (FCC) Federal Communications Commission. The acceptance letter from the FCC is maintained in our files. Registration 214666, Sep 19, 2011

1.4. Measurement Uncertainty

The data and results referenced in this document are true and accurate. The reader is cautioned that there may be errors within the calibration limits of the equipment and facilities. The measurement uncertainty was calculated for all measurements listed in this test report acc. to CISPR 16 - 4 Specification for radio disturbance and immunity measuring apparatus and methods – Part 4: Uncertainty in EMC Measurements and is documented in the Shenzhen General Testing & Inspection Technology Co., Ltd quality system acc. to DIN EN ISO/IEC 17025. Furthermore, component and process variability of devices similar to that tested may result in additional deviation. The manufacturer has the sole responsibility of continued compliance of the device.

Hereafter the best measurement capability for General Testing & Inspection laboratory is reported:

Test Items	Measurement Uncertainty	Notes
Transmitter power conducted	0.57 dB	(1)
Transmitter power Radiated	2.20 dB	(1)
Conducted spurious emission 9KHz-40 GHz	1.60 dB	(1)
Radiated spurious emission 9KHz-40 GHz	2.20 dB	(1)
Conducted Emission 9KHz-30MHz	3.39 dB	(1)
Radiated Emission 30~1000MHz	4.24 dB	(1)
Radiated Emission 1~18GHz	5.16 dB	(1)
Radiated Emission 18-40GHz	5.54 dB	(1)
Occupied Bandwidth	-----	(1)

(1) This uncertainty represents an expanded uncertainty expressed at approximately the 95% confidence level using a coverage factor of k=1.96.

2. GENERAL INFORMATION

2.1. Environmental conditions

During the measurement the environmental conditions were within the listed ranges:

Temperature:	15~35°C
Relative Humidity:	30~60 %
Air Pressure:	950~1050mba

2.2. General Description of EUT

Product Name:	Tablet PC
Model/Type reference:	A723G
List Model:	700P***, &&700*****
Model difference:	700P*** (1st* could be 0-99 or A-Z, means different client code; 2nd* could be 0-99 or A-Z or blank, stands for the shape or color of enclosure, no impact on Products safety and EMC characteristics); &&700*****(& could be "A-Z" or "a-z" , * could be "0-99" , "A-Z" , "a-z" , "-" , "/" or blank, means different client code, no impact on Products safety and EMC characteristics
Power supply:	DC 3.7V from battery, 2700mAh Battery model: 338085
Adapter1 information:	Model: EP29-05015WULZ Input: 100-240, 50/60Hz, 0.35Max Output: 5V---1500mA
Adapter2 information:	Model: SA69-050150U Input: 100-240, 50/60Hz, 0.30Max Output: 5V---1500mA
Hardware version:	V10
Software version:	V5.1
WIFI :	
Supported type:	802.11b/802.11g/802.11n(H20)
Modulation technology:	802.11b: DSSS 802.11g/802.11n(H20): OFDM
Modulation type:	802.11b: BPSK/QPSK/CCK 802.11g/802.11n(H20): BPSK/QPSK/16QAM/64QAM
Operation frequency:	802.11b/802.11g/802.11n(H20): 2412MHz~2462MHz
Channel number:	802.11b/802.11g/802.11n(H20): 11
Channel separation:	5MHz
Antenna type:	FPCB Antenna
Antenna gain:	1.2dBi
Bluetooth:	
Supported type:	Version 4.0 for low Energy
Modulation:	GFSK
Operation frequency:	2402MHz to 2480MHz



Channel number:	40
Channel separation:	2 MHz
Antenna type:	FPCB Antenna
Antenna gain:	1.2dBi

Note: For a more detailed features description, please refer to the manufacturer's specifications or the User's Manual.

2.3. Description of Test Modes

The Applicant provides communication tools software (Phone Tool V5.0.0.0) to control the EUT for staying in continuous transmitting (Duty Cycle more than 98%) and receiving mode for testing . When the test, fully-charged battery is used

Operation Frequency

BT 4.0

Channel	Frequency (MHz)
00	2402
02	2404
03	2406
⋮	⋮
19	2440
⋮	⋮
37	2476
38	2478
39	2480

WIFI Operation Frequency :

Channel	Frequency(MHz)	Channel	Frequency(MHz)
1	2412	8	2447
2	2417	9	2452
3	2422	10	2457
4	2427	11	2462
5	2432		
6	2437		
7	2442		

Power Level Setting

Phone Tool V5.0.0.0		
Test Mode	Channel	Power level
802.11b	1	20
	6	20
	11	20
802.11g	1	14
	6	14
	11	14
802.11n ht20	1	14
	6	14
	11	14
BT 4.0	00	3
	19	3
	39	3

Data Rate Used:

Preliminary tests were performed in different data rate to find the worst radiated emission. The data rate shown in the table below is the worst-case rate with respect to the specific test item. Investigation has been done on all the possible configurations for searching the worst cases. The following table is a list of the test modes shown in this test report.

Test Items	Mode	Data Rate	Channel
AC Power Conducted Emission Maximum Peak Conducted Output Power Power Spectral Density 6dB Bandwidth Spurious RF conducted emission Radiated Emission 9kHz~1GHz& Radiated Emission 1GHz~10th Harmonic	11b/DSSS	1 Mbps	1/6/11
	11g/OFDM	6 Mbps	1/6/11
	11n(20MHz)/OFDM	6.5Mbps	1/6/11
Band Edge	11b/DSSS	1 Mbps	1/11
	11g/OFDM	6 Mbps	1/11
	11n(20MHz)/OFDM	6.5Mbps	1/11

2.1. Measurement Instruments List

Maximum Conducted Output Power/Power Spectral Density / 6dB Bandwidth / Band Edge Compliance of RF Emission / Spurious RF Conducted Emission					
Item	Test Equipment	Manufacturer	Model No.	Serial No.	Calibrated until
1	Power Meter	Anritsu	ML2487B	110553	July 10,2016
2	Power Sensor	Anritsu	MA2411B	100345	July 10,2016
3	Spectrum Analyzer	Rohde & Schwarz	FSU	100105	Jan 04,2017
4	RF Cable	Schwarzbeck	AH32D4	SF0150	Jan 04,2017
5	Temporary Antenna connector	Schwarzbeck	SMA24D	ED1201	Jan 04,2017

Note: The temporary antenna connector is soldered on the PCB board in order to perform conducted tests and this temporary antenna connector is listed in the equipment list.

Conducted Emission					
Item	Test Equipment	Manufacturer	Model No.	Serial No.	Calibrate until
1	LISN	R&S	ENV216	101112	Jan 04,2017
2	LISN	R&S	ENV216	101113	Jan 04,2017
3	EMI Test Receiver	R&S	ESCI	100920	Jan 04,2017
4	Cable	Schwarzbeck	AK9515E	33156	Jan 04,2017

Radiated Emission					
Item	Test Equipment	Manufacturer	Model No.	Serial No.	Calibrated until
1	EMI Test Receiver	R&S	ESCI	100967	Jan 04,2017
2	High pass filter	micro-tranics	HPM50111	34202	Jan 04,2017
3	Log-Bicon Antenna	Schwarzbeck	CBL6141A	4180	Jan 04,2017
4	Ultra-Broadband Antenna	ShwarzBeck	BBHA9170	25841	Jan 07,2017
5	Loop Antenna	LAPLAC	RF300	9138	Jan 07,2017
6	Spectrum Analyzer	Rohde & Schwarz	FSU	100105	Jan 04,2017
7	Horn Antenna	Schwarzbeck	BBHA 9120D	648	Jan 07,2017
8	Pre-Amplifier	HP	8447D	1937A03050	Jan 04,2017
9	Pre-Amplifier	EMCI	EMC05183 5	980075	Jan 04,2017
10	Antenna Mast	UC	UC3000	N/A	N/A
11	Turn Table	UC	UC3000	N/A	N/A
12	Cable Below 1GHz	Schwarzbeck	AK9515E	33155	Jan 04,2017
13	Cable Above 1GHz	Hubersuhner	SUCOFLEX1 02	DA1580	Jan 04,2017

- Note: 1. The Cal.Interval was one year.
 2. The cable loss has calculated in test result which connection between each test instruments.

3. TEST CONDITIONS AND RESULTS

3.1. Conducted Emission (AC Main)

LIMIT

FCC CFR Title 47 Part 15 Subpart C Section 15.207

Frequency range (MHz)	Limit (dBuV)	
	Quasi-peak	Average
0.15-0.5	66 to 56*	56 to 46*
0.5-5	56	46
5-30	60	50

* Decreases with the logarithm of the frequency.

TEST CONFIGURATION

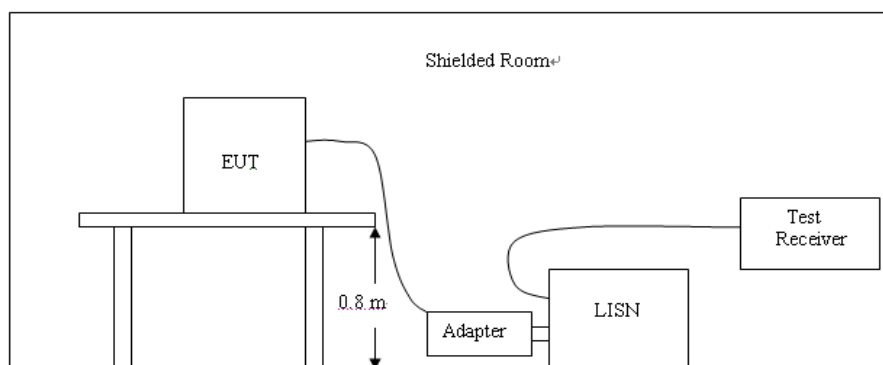

TEST PROCEDURE

1. The equipment was set up as per the test configuration to simulate typical actual usage per the user's manual. The EUT is a tabletop system; a wooden table with a height of 0.8 meters is used and is placed on the ground plane as per ANSI C63.10-2013.
2. Support equipment, if needed, was placed as per ANSI C63.10-2013
3. All I/O cables were positioned to simulate typical actual usage as per ANSI C63.10-2013
4. The EUT received DC5V power from the adapter, the adapter received AC120V/60Hz power through a Line Impedance Stabilization Network (LISN) which supplied power source and was grounded to the ground plane.
5. All support equipments received AC power from a second LISN, if any.
6. The EUT test program was started. Emissions were measured on each current carrying line of the EUT using a spectrum Analyzer / Receiver connected to the LISN powering the EUT. The LISN has two monitoring points: Line 1 (Hot Side) and Line 2 (Neutral Side). Two scans were taken: one with Line 1 connected to Analyzer / Receiver and Line 2 connected to a 50 ohm load; the second scan had Line 1 connected to a 50 ohm load and Line 2 connected to the Analyzer / Receiver.
7. Analyzer / Receiver scanned from 150 KHz to 30MHz for emissions in each of the test modes.

8. During the above scans, the emissions were maximized by cable manipulation.

TEST RESULTS

Note: We tested all modes, recorded the worst case at wifi 802.11b mode Low Channel and BT4.0 Low Channel

A. For 802.11b Low Channel

Adapter: EP29-05015WULZ

SCAN TABLE: "Vol (9K-30M) FIN-N"
 Short Description: 150K-30M Voltage

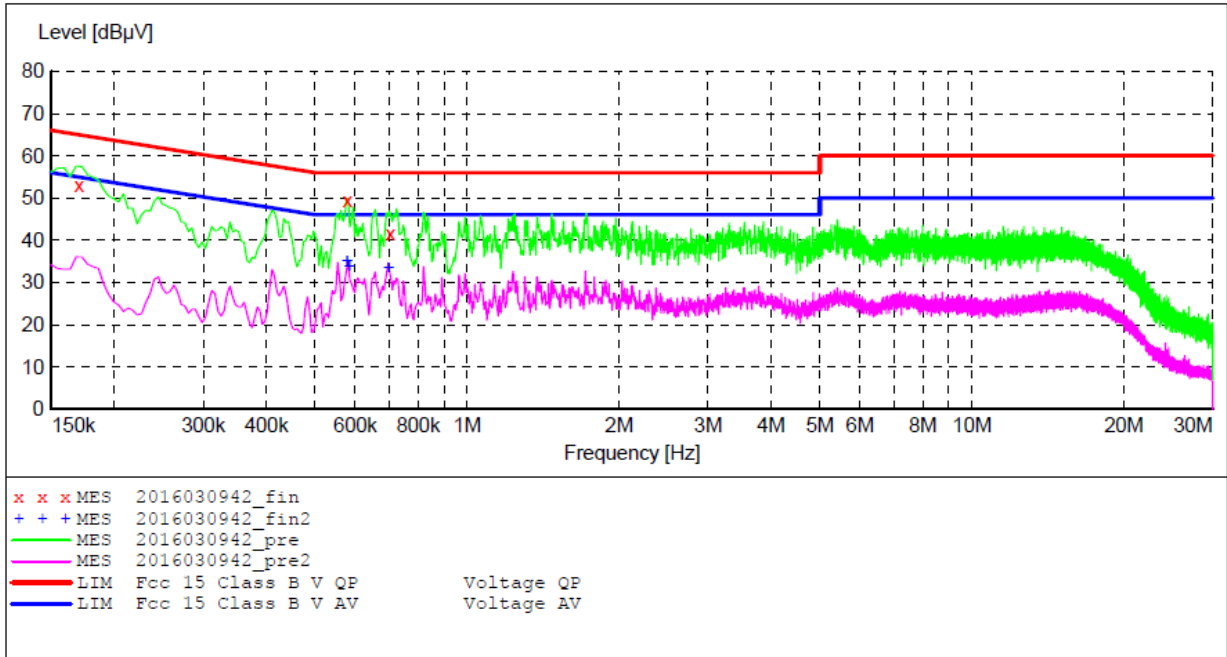

MEASUREMENT RESULT: "2016030942_fin"

3/9/2016 10:28AM

Frequency MHz	Level dBµV	Transd dB	Limit dBµV	Margin dB	Detector	Line	PE
0.170000	53.10	9.7	65	11.9	QP	L1	GND
0.578000	49.30	9.8	56	6.7	QP	L1	GND
0.704000	41.60	9.9	56	14.4	QP	L1	GND

MEASUREMENT RESULT: "2016030942_fin2"

3/9/2016 10:28AM

Frequency MHz	Level dBµV	Transd dB	Limit dBµV	Margin dB	Detector	Line	PE
0.578000	35.00	9.8	46	11.0	AV	L1	GND
0.584000	33.60	9.8	46	12.4	AV	L1	GND
0.698000	33.50	9.9	46	12.5	AV	L1	GND

LINE **N**

SCAN TABLE: "Vol (9K-30M) FIN-N"
 Short Description: 150K-30M Voltage

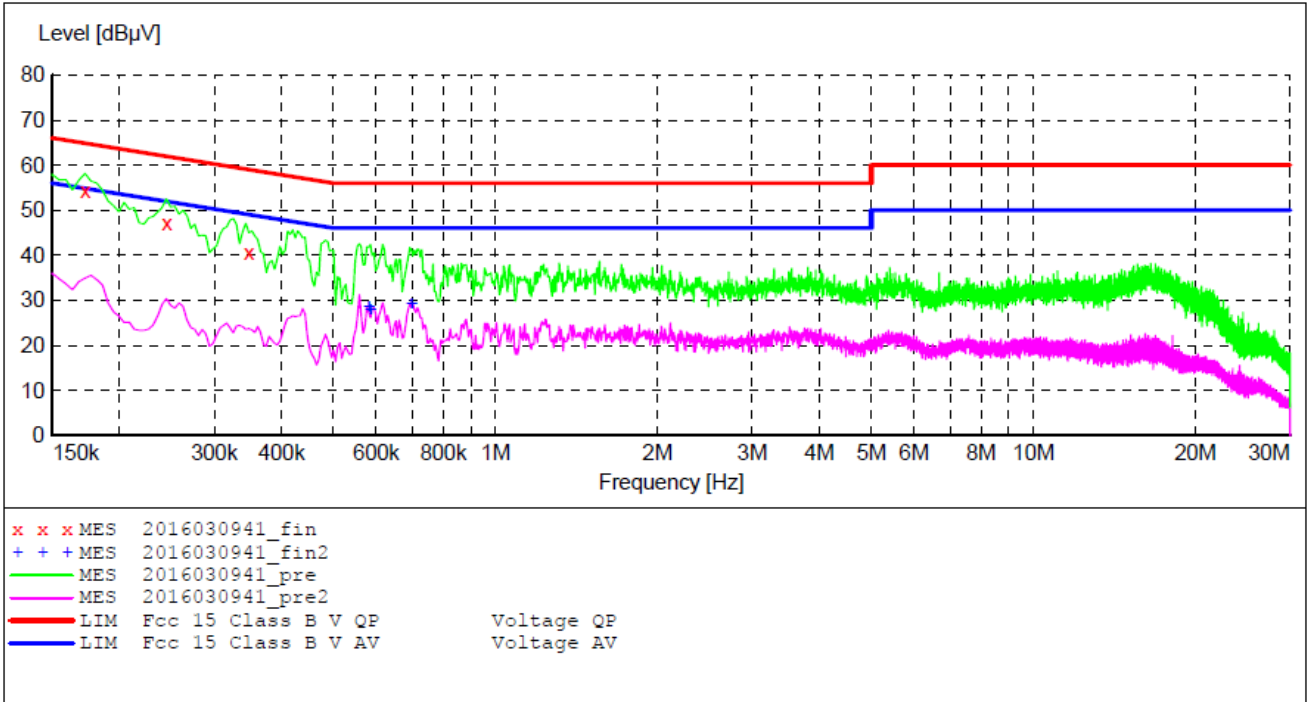

MEASUREMENT RESULT: "2016030941_fin"

3/9/2016 10:22AM

Frequency MHz	Level dBµV	Transd dB	Limit dBµV	Margin dB	Detector	Line	PE
0.172500	54.20	9.5	65	10.6	QP	N	GND
0.244500	47.20	9.5	62	14.7	QP	N	GND
0.348000	40.60	9.5	59	18.4	QP	N	GND

MEASUREMENT RESULT: "2016030941_fin2"

3/9/2016 10:22AM

Frequency MHz	Level dBµV	Transd dB	Limit dBµV	Margin dB	Detector	Line	PE
0.581000	28.40	9.6	46	17.6	AV	N	GND
0.585500	27.90	9.6	46	18.1	AV	N	GND
0.698000	29.10	9.6	46	16.9	AV	N	GND

Adapter: SA69-050150U

LINE

L

SCAN TABLE: "Vol (9K-30M) FIN-N"

Short Description: 150K-30M Voltage

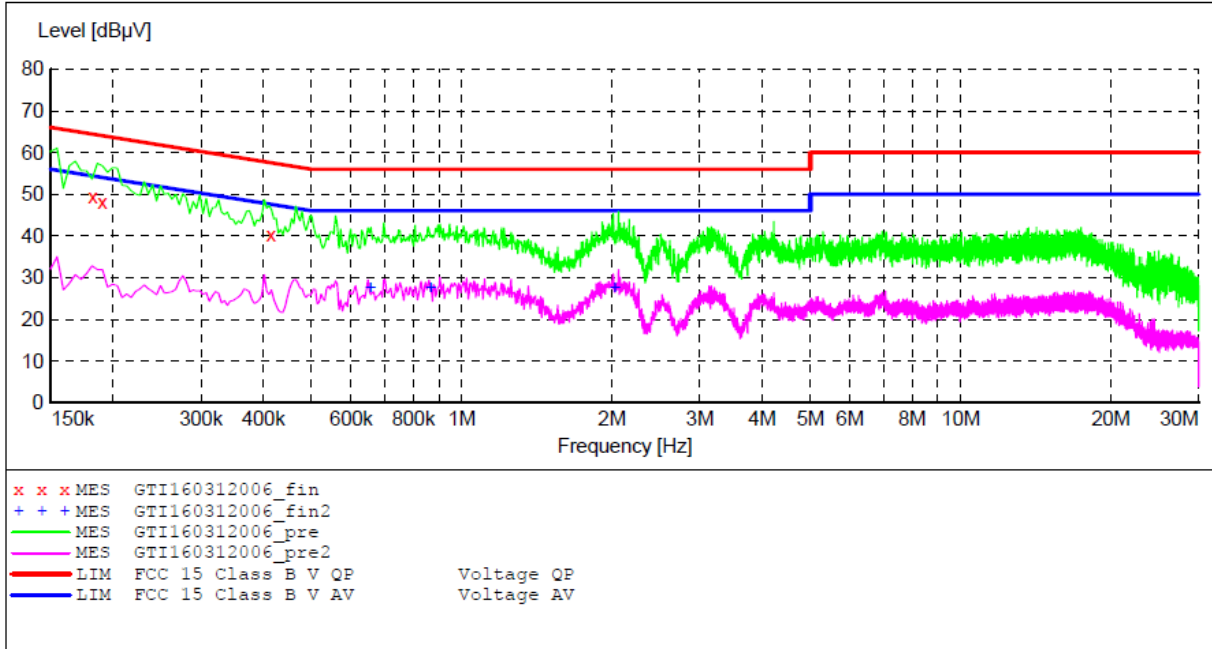

MEASUREMENT RESULT: "GTI160312006_fin"

3/12/2016 9:21AM

Frequency MHz	Level dBµV	Transd dB	Limit dBµV	Margin dB	Detector	Line	PE
0.182000	49.40	9.7	64	15.0	QP	L1	GND
0.190000	48.20	9.7	64	15.8	QP	L1	GND
0.414000	40.20	9.8	58	17.4	QP	L1	GND

MEASUREMENT RESULT: "GTI160312006_fin2"

3/12/2016 9:21AM

Frequency MHz	Level dBµV	Transd dB	Limit dBµV	Margin dB	Detector	Line	PE
0.656000	27.40	9.9	46	18.6	AV	L1	GND
0.866000	27.40	10.0	46	18.6	AV	L1	GND
2.024000	27.60	10.3	46	18.4	AV	L1	GND

LINE N

SCAN TABLE: "Vol (9K-30M) FIN-N"

Short Description: 150K-30M Voltage

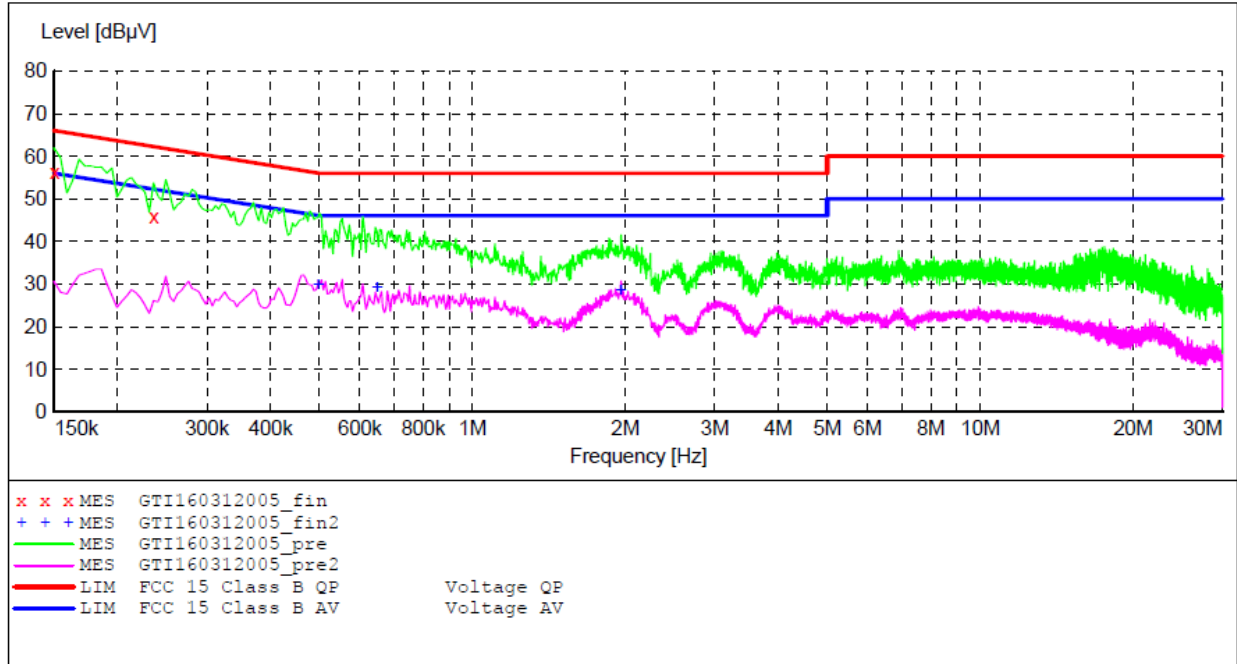

MEASUREMENT RESULT: "GTI160312005_fin"

3/12/2016 9:19AM

Frequency MHz	Level dBuV	Transd dB	Limit dBuV	Margin dB	Detector	Line	PE
0.150000	56.10	9.5	66	9.9	QP	N	GND
0.235500	45.80	9.5	62	16.5	QP	N	GND

MEASUREMENT RESULT: "GTI160312005_fin2"

3/12/2016 9:19AM

Frequency MHz	Level dBuV	Transd dB	Limit dBuV	Margin dB	Detector	Line	PE
0.496500	29.80	9.5	46	16.3	AV	N	GND
0.648500	29.00	9.6	46	17.0	AV	N	GND
1.958000	28.40	10.0	46	17.6	AV	N	GND

B. For BT 4.0 Low Channel

Adapter: EP29-05015WULZ

LINE

L

SCAN TABLE: "Vol (9K-30M) FIN-N"

Short Description: 150K-30M Voltage

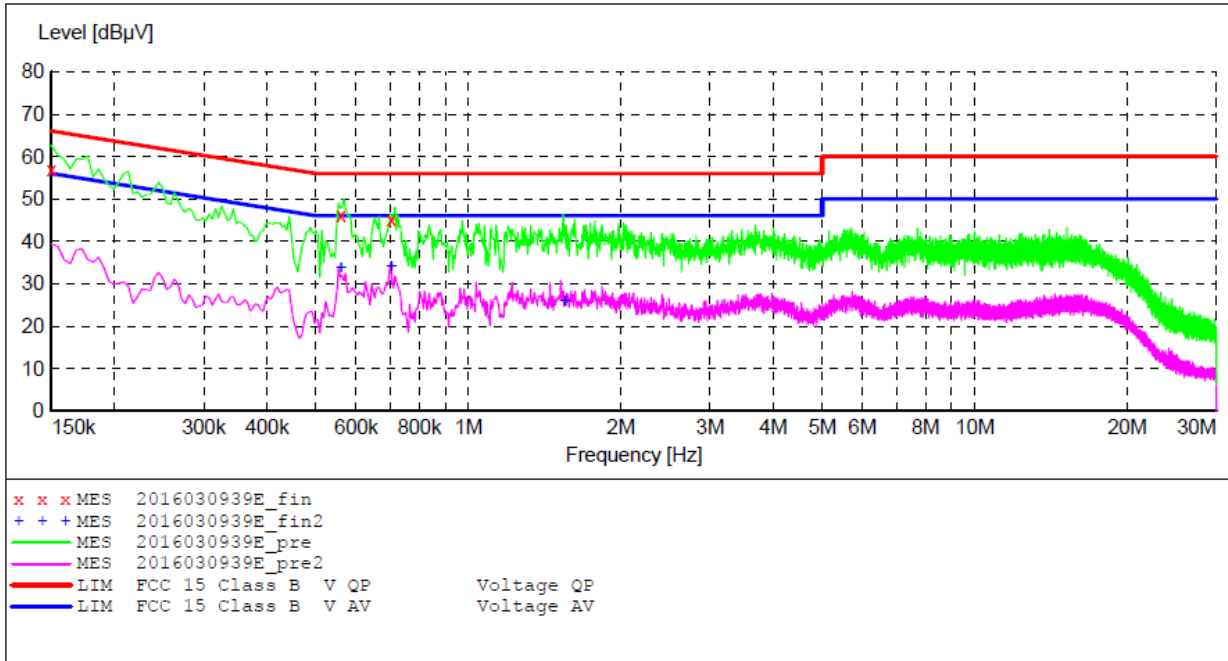

MEASUREMENT RESULT: "2016030939E_fin"

3/9/2016 10:17AM

Frequency MHz	Level dBµV	Transd dB	Limit dBµV	Margin dB	Detector	Line	PE
0.150000	56.90	9.8	66	9.1	QP	L1	GND
0.560000	46.00	9.8	56	10.0	QP	L1	GND
0.704000	45.10	9.9	56	10.9	QP	L1	GND

MEASUREMENT RESULT: "2016030939E_fin2"

3/9/2016 10:17AM

Frequency MHz	Level dBµV	Transd dB	Limit dBµV	Margin dB	Detector	Line	PE
0.560000	33.60	9.8	46	12.4	AV	L1	GND
0.704000	34.20	9.9	46	11.8	AV	L1	GND
1.550000	25.80	10.2	46	20.2	AV	L1	GND

LINE N

SCAN TABLE: "Vol (9K-30M) FIN-N"

Short Description: 150K-30M Voltage

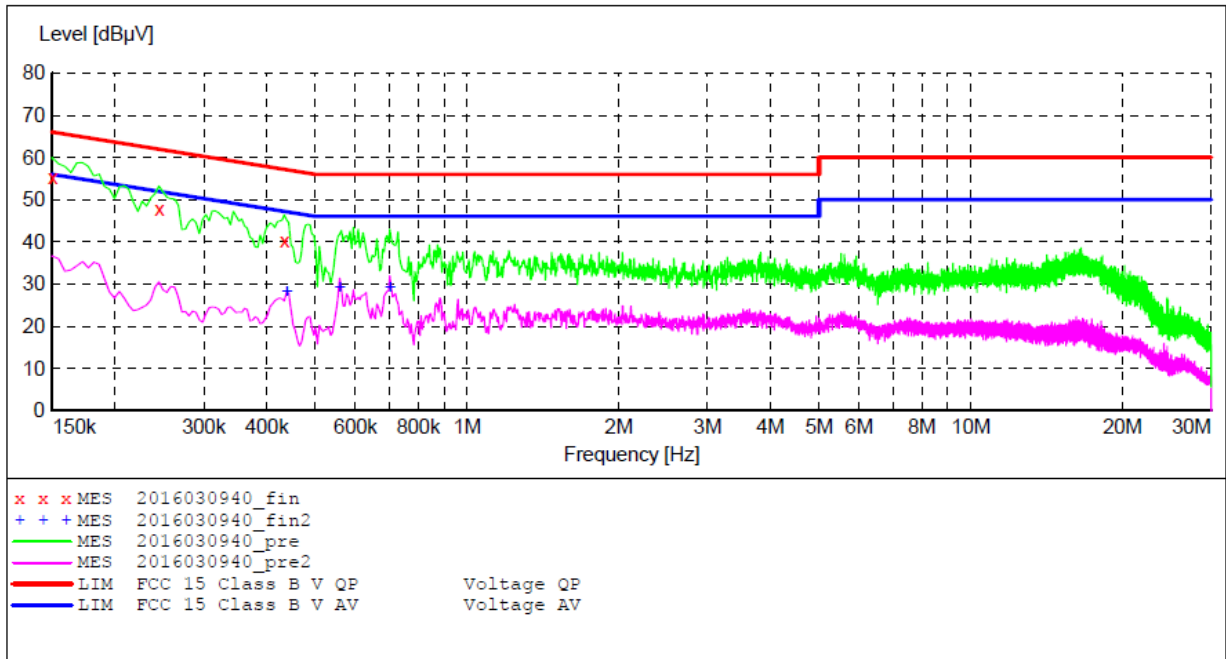

MEASUREMENT RESULT: "2016030940_fin"

3/9/2016 10:19AM

Frequency MHz	Level dBµV	Transd dB	Limit dBµV	Margin dB	Detector	Line	PE
0.150000	55.30	9.5	66	10.7	QP	N	GND
0.244500	47.70	9.5	62	14.2	QP	N	GND
0.433500	40.20	9.5	57	17.0	QP	N	GND

MEASUREMENT RESULT: "2016030940_fin2"

3/9/2016 10:19AM

Frequency MHz	Level dBµV	Transd dB	Limit dBµV	Margin dB	Detector	Line	PE
0.438000	28.30	9.5	47	18.8	AV	N	GND
0.558500	29.00	9.6	46	17.0	AV	N	GND
0.702500	29.00	9.6	46	17.0	AV	N	GND

Adapter: SA69-050150U

LINE

L

SCAN TABLE: "Vol (9K-30M) FIN-N"

Short Description: 150K-30M Voltage

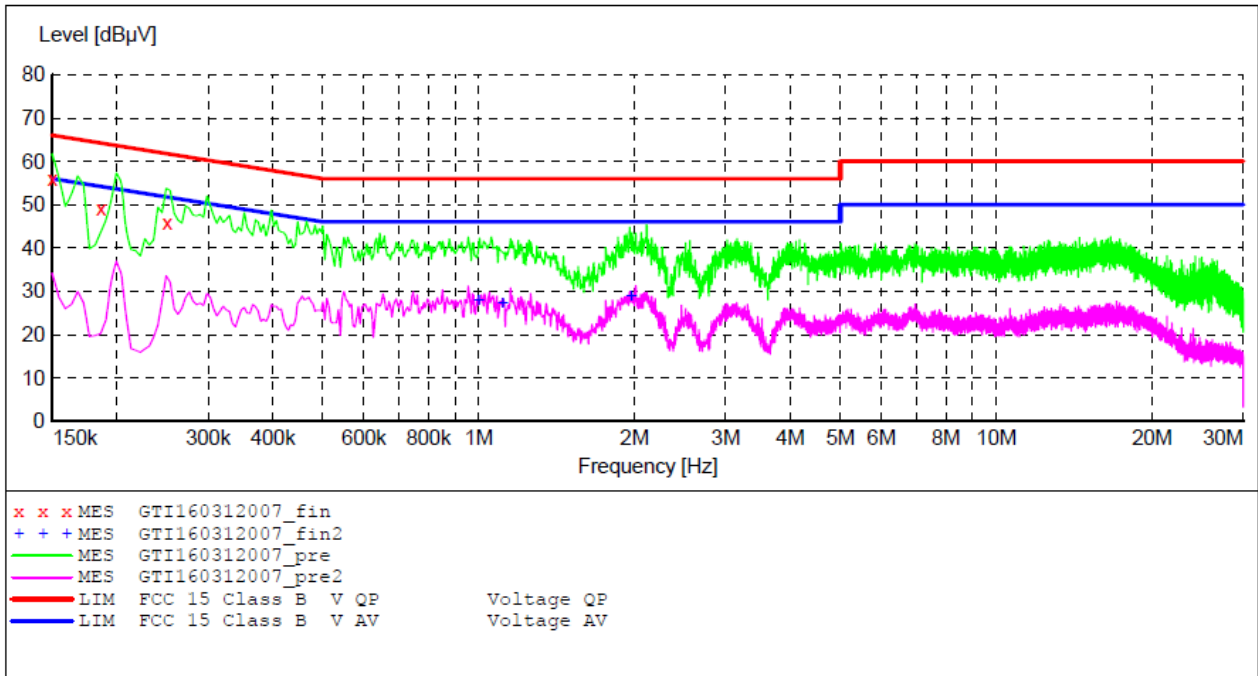

MEASUREMENT RESULT: "GTI160312007_fin"

3/12/2016 9:24AM

Frequency MHz	Level dBuV	Transd dB	Limit dBuV	Margin dB	Detector	Line	PE
0.150000	55.80	9.8	66	10.2	QP	L1	GND
0.186000	49.10	9.7	64	15.1	QP	L1	GND
0.250000	45.70	9.7	62	16.1	QP	L1	GND

MEASUREMENT RESULT: "GTI160312007_fin2"

3/12/2016 9:24AM

Frequency MHz	Level dBuV	Transd dB	Limit dBuV	Margin dB	Detector	Line	PE
0.998000	27.90	10.0	46	18.1	AV	L1	GND
1.112000	27.20	10.0	46	18.8	AV	L1	GND
1.970000	28.70	10.3	46	17.3	AV	L1	GND

LINE

N

SCAN TABLE: "Vol (9K-30M) FIN-N"

Short Description: 150K-30M Voltage

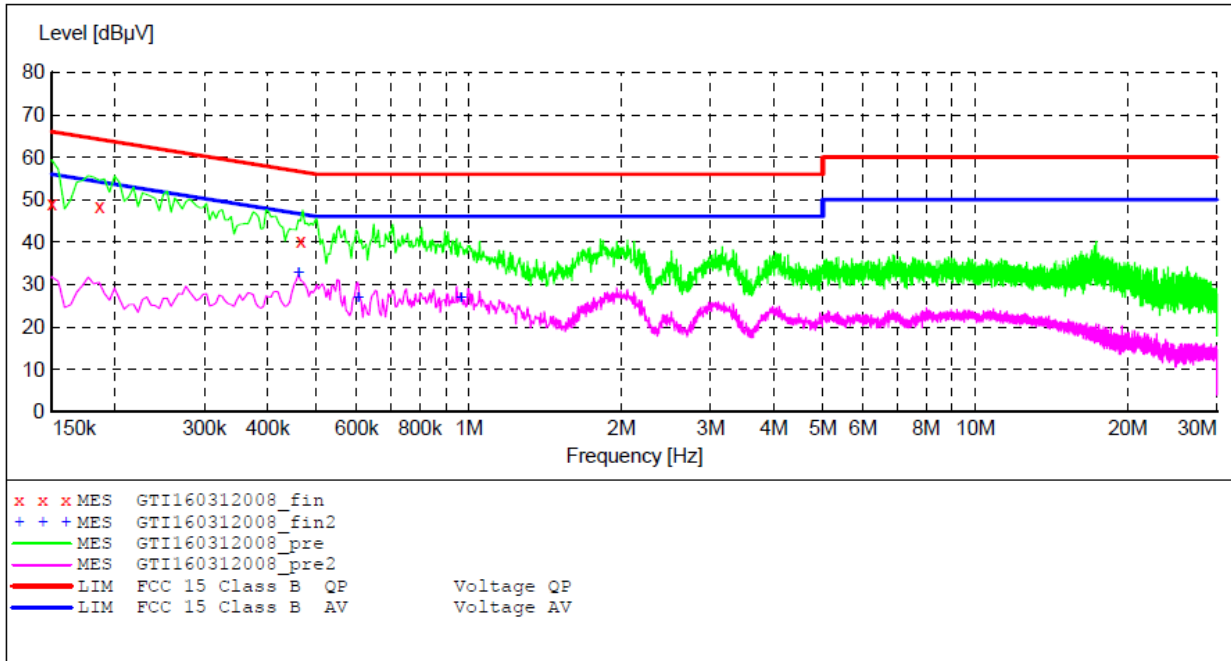

MEASUREMENT RESULT: "GTI160312008_fin"

3/12/2016 9:26AM

Frequency MHz	Level dBuV	Transd dB	Limit dBuV	Margin dB	Detector	Line	PE
0.150000	49.10	9.5	66	16.9	QP	N	GND
0.186000	48.50	9.5	64	15.7	QP	N	GND
0.465000	40.30	9.5	57	16.3	QP	N	GND

MEASUREMENT RESULT: "GTI160312008_fin2"

3/12/2016 9:26AM

Frequency MHz	Level dBuV	Transd dB	Limit dBuV	Margin dB	Detector	Line	PE
0.460500	32.60	9.5	47	14.1	AV	N	GND
0.603500	27.00	9.6	46	19.0	AV	N	GND
0.963500	26.80	9.7	46	19.2	AV	N	GND

3.2. Radiated Emission

Limit

For intentional device, according to § 15.209(a), the general requirement of field strength of radiated emission from intentional radiators at a distance of 3 meters shall not exceed the following table. According to § 15.247(d), in any 100kHz bandwidth outside the frequency band in which the EUT is operating, the radio frequency power that is produced by the intentional radiator shall be at least 20dB below that in the 100kHz bandwidth within the band that contains the highest level of desired power.

The frequency spectrum above 1 GHz for Transmitter was investigated. All emission not reported are much lower than the prescribed limits. Set the RBW=1MHz, VBW=3MHz for Peak Detector while the RBW=1MHz, VBW=10Hz for Average Detector, Readings are both peak and average values. The pre-test have done for the EUT in three axes and found the worst emission at position shown in test setup photos.

Frequency (MHz)	Distance (Meters)	Radiated (dBuV/m)	Radiated (μ V/m)
0.009-0.49	3	$20\log(2400/F(\text{KHz}))+40\log(300/3)$	$2400/F(\text{KHz})$
0.49-1.705	3	$20\log(24000/F(\text{KHz}))+40\log(30/3)$	$24000/F(\text{KHz})$
1.705-30	3	$20\log(30)+40\log(30/3)$	30
30-88	3	40.0	100
88-216	3	43.5	150
216-960	3	46.0	200
Above 960	3	54.0	500

Test Procedure

1. For below 1GHz test, The EUT was placed on a turn table which is 0.8m above ground plane; For Above 1GHz test, The EUT was placed on a turn table which is 1.5m above ground plane
2. Maximum procedure was performed by raising the receiving antenna from 1m to 4m and rotating the turn table from 0° to 360° to acquire the highest emissions from EUT
3. And also, each emission was to be maximized by changing the polarization of receiving antenna both horizontal and vertical.
4. Repeat above procedures until all frequency measurements have been completed.

Note: For the radiated emission test above 1GHz:

Place the measurement antenna away from each area of the EUT determined to be a source of emissions at the specified measurement distance, while keeping the measurement antenna aimed at the source of emissions at each frequency of significant emissions, with polarization oriented for maximum response. The measurement antenna may have to be higher or lower than the EUT, depending on the radiation pattern of the emission and staying aimed at the emission source for receiving the maximum signal. The final measurement antenna elevation shall be that which maximizes the emissions. The measurement antenna elevation for maximum emissions shall be restricted to a range of heights of from 1 m to 4 m above the ground or reference ground plane.

Field Strength Calculation

The field strength is calculated by adding the Antenna Factor and Cable Factor and subtracting the Amplifier Gain and Duty Cycle Correction Factor (if any) from the measured reading. The basic equation with a sample calculation is as follows:

$$FS = RA + AF + CL - AG$$

Where FS = Field Strength	CL = Cable Attenuation Factor (Cable Loss)
RA = Reading Amplitude	AG = Amplifier Gain
AF = Antenna Factor	

For example

Frequency (MHz)	FS (dBµV/m)	RA (dBµV/m)	AF (dB)	CL (dB)	AG (dB)	Transd (dB)
150.00	40	58.1	12.2	1.6	31.90	-18.1

$$\text{Transd} = \text{AF} + \text{CL} - \text{AG}$$

Test Configuration

For the actual test configuration, please refer to the related Item –EUT Test Photos.

Frequency range 9 KHz – 30MHz

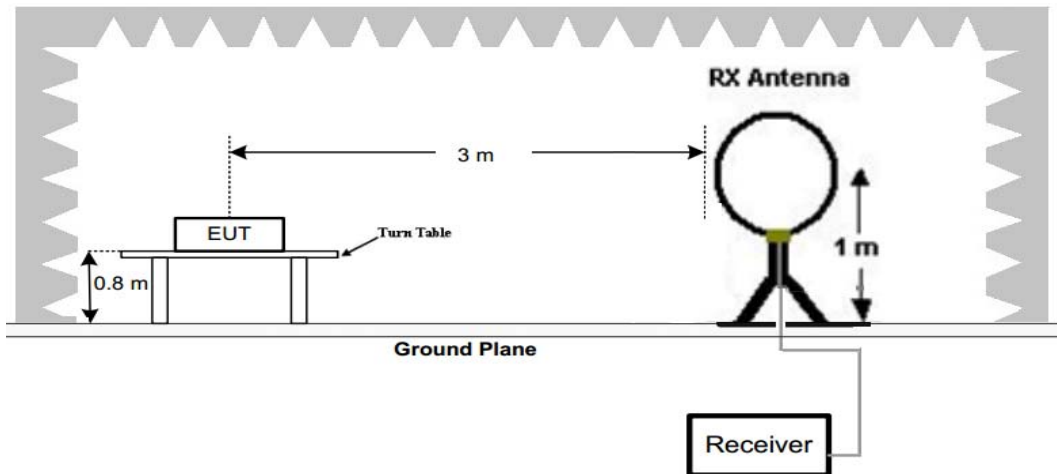

Frequency range 30MHz – 1000MHz

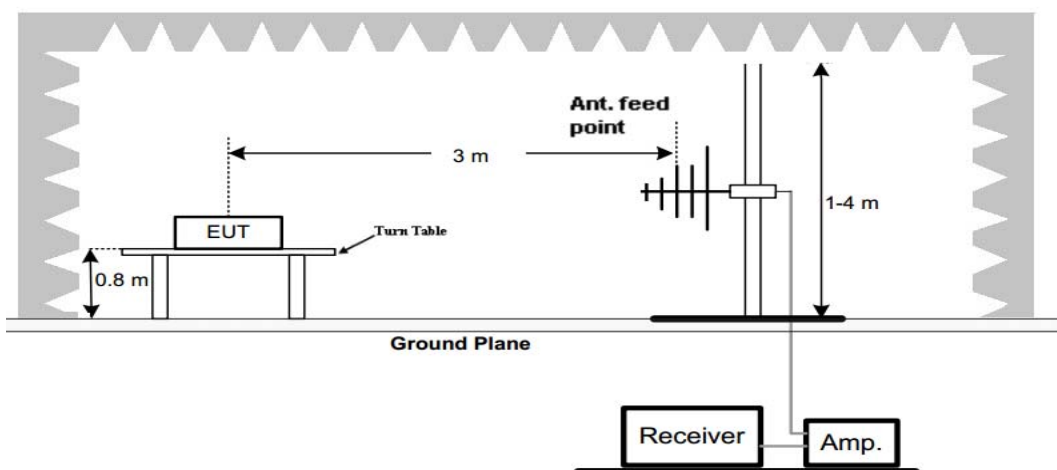

Frequency range above 1GHz-25GHz

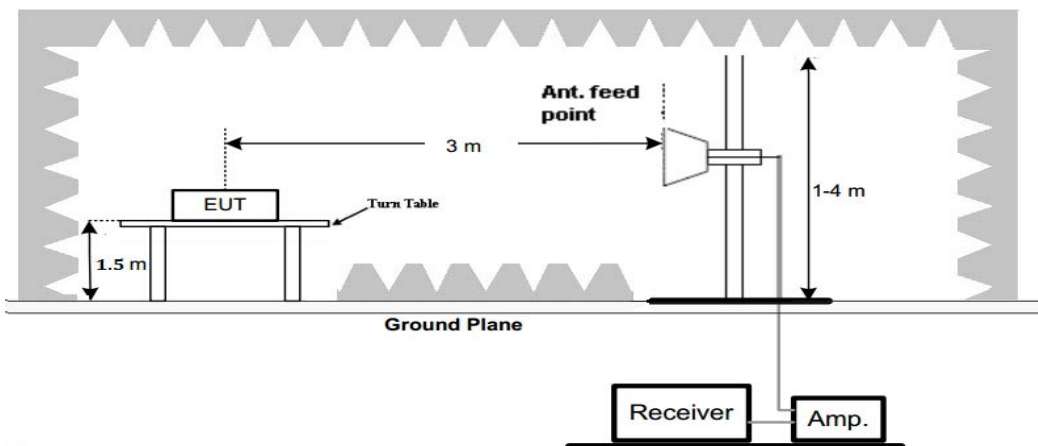

Test Results

Remark:

1. We tested three channels for each mode and recorded worst case at low channel of 802.11b and BT 4.0 mode from 30MHz to 1GHz.
2. We tested three channels for each mode and recorded worst case at low channel of 802.11b mode for below 30MHz;

For 9 KHz-30MHz

For 802.11B Low Channel

Frequency (MHz)	Corrected Reading (dBuV/m)@3m	FCC Limit (dBuV/m) @3m	Margin (dB)	Detector	Result
0.14	53.02	104.68	51.66	QP	PASS
1.18	48.14	66.17	18.03	QP	PASS
14.36	33.62	69.54	35.92	QP	PASS
24.74	47.02	69.54	22.52	QP	PASS

For 30MHz-1GHz
For 802.11B Low Channel

Horizontal

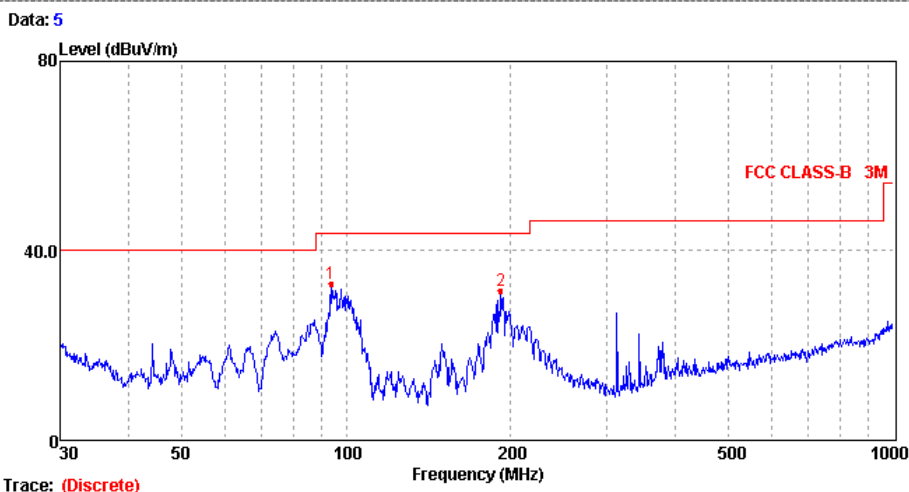

Mark	Frequency MHz	Level dBuV/m	Factor dB/m	Reading dBuV	Limit dBuV/m	Margin dB	Polarization	Detector
1	93.77	32.63	-19.89	52.52	43.50	10.87	HORIZONTAL	Peak
2	191.75	31.27	-18.64	49.91	43.50	12.23	HORIZONTAL	Peak

Vertical

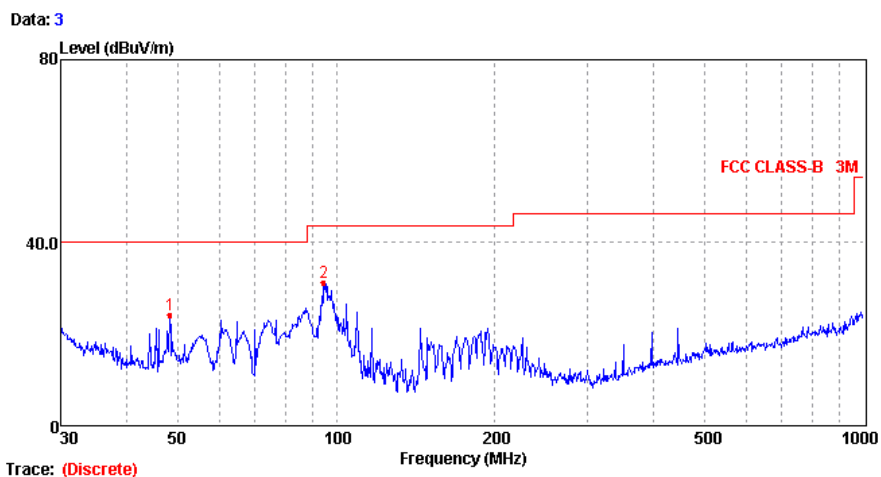

Mark	Frequency MHz	Level dBuV/m	Factor dB/m	Reading dBuV	Limit dBuV/m	Margin dB	Polarization	Detector
1	48.33	23.91	-14.84	38.75	40.00	16.09	VERTICAL	Peak
2	94.76	30.97	-19.81	50.78	43.50	12.53	VERTICAL	Peak

For BT 4.0 Low Channel

Horizontal

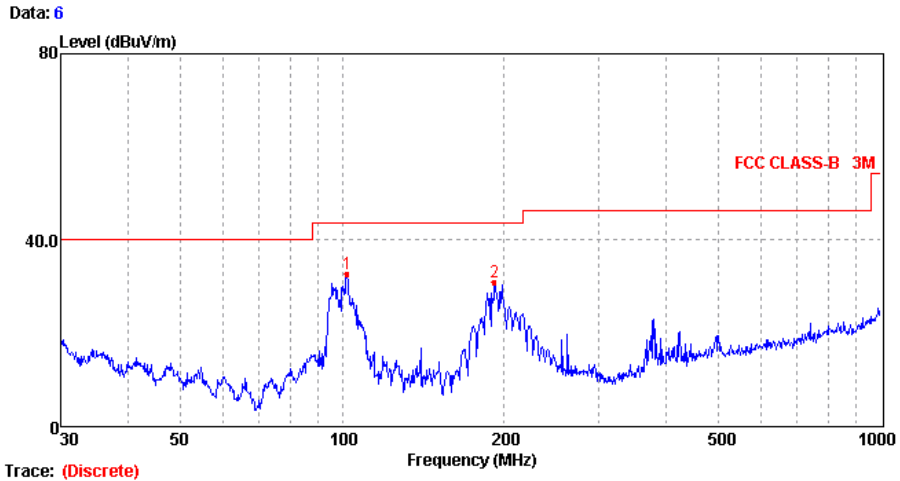

Mark	Frequency MHz	Level dBuV/m	Factor dB/m	Reading dBuV	Limit dBuV/m	Margin dB	Polarization	Detector
1	102.00	32.39	-19.32	51.71	43.50	11.11	HORIZONTAL	Peak
2	191.75	30.73	-18.64	49.37	43.50	12.77	HORIZONTAL	Peak

Vertical

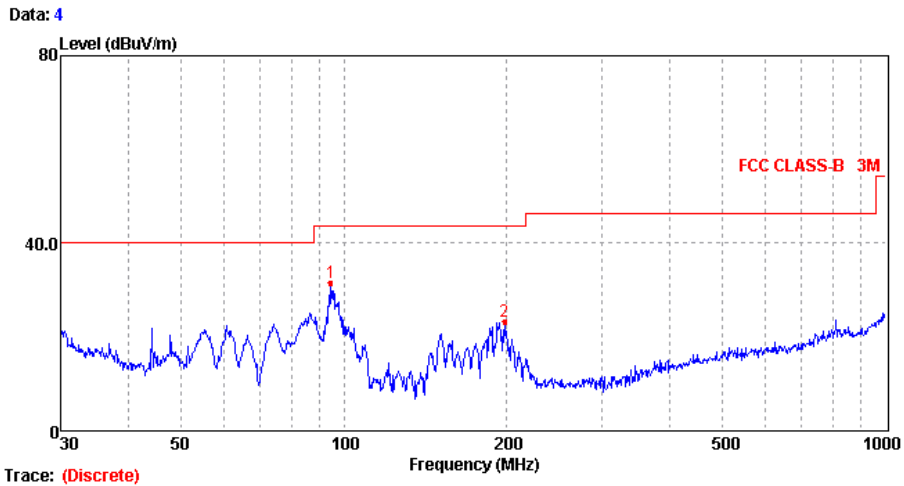

Mark	Frequency MHz	Level dBuV/m	Factor dB/m	Reading dBuV	Limit dBuV/m	Margin dB	Polarization	Detector
1	94.76	31.33	-19.81	51.14	43.50	12.17	VERTICAL	Peak
2	197.89	22.96	-18.05	41.01	43.50	20.54	VERTICAL	Peak

For 1GHz to 25GHz

802.11b Mode (above 1GHz)

Frequency(MHz):				2412			Polarity:			HORIZONTAL		
No.	Frequency (MHz)	Emission Level (dBuV/m)		Limit (dBuV/m)	Margin (dB)	Antenna Height (m)	Table Angle (Degree)	Raw Value (dBuV)	Antenna Factor (dB/m)	Cable Factor (dB)	Pre-amplifier (dB)	Correction Factor (dB/m)
1	4824	51.09	PK	74.00	22.91	1.00	97	48.99	31.60	7.00	36.5	2.10
1	4824	43.95	AV	54.00	10.05	1.00	97	41.85	31.60	7.00	36.5	2.10
2	7236	44.61	PK	74.00	29.39	1.00	97	33.68	37.33	8.90	35.3	10.93
2	7236	37.24	AV	54.00	16.76	1.00	97	26.31	37.33	8.90	35.3	10.93

Frequency(MHz):				2412			Polarity:			VERTICAL		
No.	Frequency (MHz)	Emission Level (dBuV/m)		Limit (dBuV/m)	Margin (dB)	Antenna Height (m)	Table Angle (Degree)	Raw Value (dBuV)	Antenna Factor (dB/m)	Cable Factor (dB)	Pre-amplifier (dB)	Correction Factor (dB/m)
1	4824	51.61	PK	74.00	22.39	1.00	201	49.51	31.60	7.00	36.5	2.10
1	4824	46.60	AV	54.00	7.40	1.00	201	44.50	31.60	7.00	36.5	2.10
2	7236	42.75	PK	74.00	31.25	1.00	201	31.82	37.33	8.90	35.3	10.93
2	7236	36.41	AV	54.00	17.59	1.00	201	25.48	37.33	8.90	35.3	10.93

Frequency(MHz):				2437			Polarity:			HORIZONTAL		
No.	Frequency (MHz)	Emission Level (dBuV/m)		Limit (dBuV/m)	Margin (dB)	Antenna Height (m)	Table Angle (Degree)	Raw Value (dBuV)	Antenna Factor (dB/m)	Cable Factor (dB)	Pre-amplifier (dB)	Correction Factor (dB/m)
1	4874.00	51.03	PK	74.00	22.97	1.00	91	48.91	31.02	7.60	36.5	2.12
1	4874.00	44.11	AV	54.00	9.89	1.00	91	41.99	31.02	7.60	36.5	2.12
2	7311.00	43.84	PK	74.00	30.16	1.00	91	32.76	37.28	8.60	34.8	11.08
2	7311.00	37.53	AV	54.00	16.47	1.00	91	26.45	37.28	8.60	34.8	11.08

Frequency(MHz):				2437			Polarity:			VERTICAL		
No.	Frequency (MHz)	Emission Level (dBuV/m)		Limit (dBuV/m)	Margin (dB)	Antenna Height (m)	Table Angle (Degree)	Raw Value (dBuV)	Antenna Factor (dB/m)	Cable Factor (dB)	Pre-amplifier (dB)	Correction Factor (dB/m)
1	4874.00	51.16	PK	74.00	22.84	1.00	211	51.16	31.02	7.60	36.5	2.12
1	4874.00	45.57	AV	54.00	8.43	1.00	211	45.57	31.02	7.60	36.5	2.12
2	7311.00	45.25	PK	74.00	28.75	1.00	211	45.25	37.28	8.60	34.8	11.08
2	7311.00	37.21	AV	54.00	16.79	1.00	211	37.21	37.28	8.60	34.8	11.08

Frequency(MHz):				2462			Polarity:			HORIZONTAL		
No.	Frequency (MHz)	Emission Level (dBuV/m)		Limit (dBuV/m)	Margin (dB)	Antenna Height (m)	Table Angle (Degree)	Raw Value (dBuV)	Antenna Factor (dB/m)	Cable Factor (dB)	Pre-amplifier (dB)	Correction Factor (dB/m)
1	4924.00	50.32	PK	74.00	23.68	1.00	109	47.12	31.58	7.82	36.2	3.20
1	4924.00	46.29	AV	54.00	7.71	1.00	109	43.09	31.58	7.82	36.2	3.20
2	7386.00	44.38	PK	74.00	29.62	1.00	109	32.44	38.51	8.73	35.3	11.94
2	7386.00	37.98	AV	54.00	16.02	1.00	109	26.04	38.51	8.73	35.3	11.94

Frequency(MHz):				2462			Polarity:			VERTICAL		
No.	Frequency (MHz)	Emission Level (dBuV/m)		Limit (dBuV/m)	Margin (dB)	Antenna Height (m)	Table Angle (Degree)	Raw Value (dBuV)	Antenna Factor (dB/m)	Cable Factor (dB)	Pre-amplifier (dB)	Correction Factor (dB/m)
1	4924.00	50.66	PK	74.00	23.34	1.00	97	48.56	31.58	7.82	36.2	3.20
1	4924.00	42.29	AV	54.00	11.71	1.00	97	40.19	31.58	7.82	36.2	3.20
2	7386.00	45.78	PK	74.00	28.22	1.00	97	34.85	38.51	8.73	35.3	11.94
2	7386.00	35.49	AV	54.00	18.51	1.00	97	24.56	38.51	8.73	35.3	11.94

802.11g Mode (above 1GHz)

Frequency(MHz):			2412			Polarity:			HORIZONTAL		
No.	Frequency (MHz)	Emission Level (dBuV/m)	Limit (dBuV/m)	Margin (dB)	Antenna Height (m)	Table Angle (Degree)	Raw Value (dBuV)	Antenna Factor (dB/m)	Cable Factor (dB)	Pre-amplifier (dB)	Correction Factor (dB/m)
1	4824	50.66 PK	74.00	23.34	1.00	97	48.56	31.60	7.00	36.5	2.10
1	4824	42.29 AV	54.00	11.71	1.00	97	40.19	31.60	7.00	36.5	2.10
2	7236	45.78 PK	74.00	28.22	1.00	97	34.85	37.33	8.90	35.3	10.93
2	7236	35.49 AV	54.00	18.51	1.00	97	24.56	37.33	8.90	35.3	10.93

Frequency(MHz):			2412			Polarity:			VERTICAL		
No.	Frequency (MHz)	Emission Level (dBuV/m)	Limit (dBuV/m)	Margin (dB)	Antenna Height (m)	Table Angle (Degree)	Raw Value (dBuV)	Antenna Factor (dB/m)	Cable Factor (dB)	Pre-amplifier (dB)	Correction Factor (dB/m)
1	4824	52.42 PK	74.00	21.58	1.00	201	50.32	31.60	7.00	36.5	2.10
1	4824	41.25 AV	54.00	12.75	1.00	201	39.15	31.60	7.00	36.5	2.10
2	7236	43.44 PK	74.00	30.56	1.00	201	32.51	37.33	8.90	35.3	10.93
2	7236	38.04 AV	54.00	15.96	1.00	201	27.11	37.33	8.90	35.3	10.93

Frequency(MHz):			2437			Polarity:			HORIZONTAL		
No.	Frequency (MHz)	Emission Level (dBuV/m)	Limit (dBuV/m)	Margin (dB)	Antenna Height (m)	Table Angle (Degree)	Raw Value (dBuV)	Antenna Factor (dB/m)	Cable Factor (dB)	Pre-amplifier (dB)	Correction Factor (dB/m)
1	4874.00	51.15 PK	74.00	22.85	1.00	91	49.03	31.02	7.60	36.5	2.12
1	4874.00	41.85 AV	54.00	12.15	1.00	91	39.73	31.02	7.60	36.5	2.12
2	7311.00	44.05 PK	74.00	29.95	1.00	91	32.97	37.28	8.60	34.8	11.08
2	7311.00	35.98 AV	54.00	18.02	1.00	91	24.90	37.28	8.60	34.8	11.08

Frequency(MHz):			2437			Polarity:			VERTICAL		
No.	Frequency (MHz)	Emission Level (dBuV/m)	Limit (dBuV/m)	Margin (dB)	Antenna Height (m)	Table Angle (Degree)	Raw Value (dBuV)	Antenna Factor (dB/m)	Cable Factor (dB)	Pre-amplifier (dB)	Correction Factor (dB/m)
1	4874.00	50.73 PK	74.00	23.27	1.00	211	48.61	31.02	7.60	36.5	2.12
1	4874.00	42.28 AV	54.00	11.72	1.00	211	40.16	31.02	7.60	36.5	2.12
2	7311.00	43.98 PK	74.00	30.02	1.00	211	32.90	37.28	8.60	34.8	11.08
2	7311.00	35.02 AV	54.00	18.98	1.00	211	23.94	37.28	8.60	34.8	11.08

Frequency(MHz):			2462			Polarity:			HORIZONTAL		
No.	Frequency (MHz)	Emission Level (dBuV/m)	Limit (dBuV/m)	Margin (dB)	Antenna Height (m)	Table Angle (Degree)	Raw Value (dBuV)	Antenna Factor (dB/m)	Cable Factor (dB)	Pre-amplifier (dB)	Correction Factor (dB/m)
1	4924.00	51.54 PK	74.00	22.46	1.00	211	48.34	31.58	7.82	36.2	3.20
1	4924.00	42.08 AV	54.00	11.92	1.00	211	38.88	31.58	7.82	36.2	3.20
2	7386.00	43.67 PK	74.00	30.33	1.00	211	31.73	38.51	8.73	35.3	11.94
2	7386.00	36.81 AV	54.00	17.19	1.00	211	24.87	38.51	8.73	35.3	11.94

Frequency(MHz):			2462			Polarity:			VERTICAL		
No.	Frequency (MHz)	Emission Level (dBuV/m)	Limit (dBuV/m)	Margin (dB)	Antenna Height (m)	Table Angle (Degree)	Raw Value (dBuV)	Antenna Factor (dB/m)	Cable Factor (dB)	Pre-amplifier (dB)	Correction Factor (dB/m)
1	4924.00	52.08 PK	74.00	21.92	1.00	197	48.88	31.58	7.82	36.2	3.20
1	4924.00	40.52 AV	54.00	13.48	1.00	197	37.32	31.58	7.82	36.2	3.20
2	7386.00	46.00 PK	74.00	28.00	1.00	197	34.06	38.51	8.73	35.3	11.94
2	7386.00	36.47 AV	54.00	17.53	1.00	197	24.53	38.51	8.73	35.3	11.94

802.11n20 Mode (above 1GHz)

Frequency(MHz):			2412			Polarity:			HORIZONTAL		
No.	Frequency (MHz)	Emission Level (dBuV/m)	Limit (dBuV/m)	Margin (dB)	Antenna Height (m)	Table Angle (Degree)	Raw Value (dBuV)	Antenna Factor (dB/m)	Cable Factor (dB)	Pre-amplifier (dB)	Correction Factor (dB/m)
1	4824	49.61 PK	74.00	24.39	1.00	85	47.51	31.6	7.00	36.5	2.10
1	4824	43.21 AV	54.00	10.79	1.00	85	41.11	31.6	7.00	36.5	2.10
2	7236	44.21 PK	74.00	29.79	1.00	85	33.28	37.33	8.90	35.3	10.93
2	7236	35.73 AV	54.00	18.27	1.00	85	24.80	37.33	8.90	35.3	10.93

Frequency(MHz):			2412			Polarity:			VERTICAL		
No.	Frequency (MHz)	Emission Level (dBuV/m)	Limit (dBuV/m)	Margin (dB)	Antenna Height (m)	Table Angle (Degree)	Raw Value (dBuV)	Antenna Factor (dB/m)	Cable Factor (dB)	Pre-amplifier (dB)	Correction Factor (dB/m)
1	4824	51.18 PK	74.00	22.82	1.00	186	49.08	31.60	7.00	36.5	2.10
1	4824	40.60 AV	54.00	13.40	1.00	186	38.50	31.60	7.00	36.5	2.10
2	7236	43.21 PK	74.00	30.79	1.00	186	32.28	37.33	8.90	35.3	10.93
2	7236	36.66 AV	54.00	17.34	1.00	186	25.73	37.33	8.90	35.3	10.93

Frequency(MHz):			2437			Polarity:			HORIZONTAL		
No.	Frequency (MHz)	Emission Level (dBuV/m)	Limit (dBuV/m)	Margin (dB)	Antenna Height (m)	Table Angle (Degree)	Raw Value (dBuV)	Antenna Factor (dB/m)	Cable Factor (dB)	Pre-amplifier (dB)	Correction Factor (dB/m)
1	4874.00	47.88 PK	74.00	26.12	1.00	85	45.76	31.02	7.60	36.5	2.12
1	4874.00	41.54 AV	54.00	12.46	1.00	85	39.42	31.02	7.60	36.5	2.12
2	7311.00	44.24 PK	74.00	29.76	1.00	85	33.16	37.28	8.60	34.8	11.08
2	7311.00	35.43 AV	54.00	18.57	1.00	85	24.35	37.28	8.60	34.8	11.08

Frequency(MHz):			2437			Polarity:			VERTICAL		
No.	Frequency (MHz)	Emission Level (dBuV/m)	Limit (dBuV/m)	Margin (dB)	Antenna Height (m)	Table Angle (Degree)	Raw Value (dBuV)	Antenna Factor (dB/m)	Cable Factor (dB)	Pre-amplifier (dB)	Correction Factor (dB/m)
1	4874.00	49.03 PK	74.00	24.97	1.00	216	46.91	31.02	7.60	36.5	2.12
1	4874.00	40.67 AV	54.00	13.33	1.00	216	38.55	31.02	7.60	36.5	2.12
2	7311.00	43.48 PK	74.00	30.52	1.00	216	32.40	37.28	8.60	34.8	11.08
2	7311.00	34.52 AV	54.00	19.48	1.00	216	23.44	37.28	8.60	34.8	11.08

Frequency(MHz):			2462			Polarity:			HORIZONTAL		
No.	Frequency (MHz)	Emission Level (dBuV/m)	Limit (dBuV/m)	Margin (dB)	Antenna Height (m)	Table Angle (Degree)	Raw Value (dBuV)	Antenna Factor (dB/m)	Cable Factor (dB)	Pre-amplifier (dB)	Correction Factor (dB/m)
1	4924.00	49.44 PK	74.00	24.56	1.00	221	46.24	31.58	7.82	36.2	3.20
1	4924.00	42.59 AV	54.00	11.41	1.00	221	39.39	31.58	7.82	36.2	3.20
2	7386.00	44.34 PK	74.00	29.66	1.00	221	32.40	38.51	8.73	35.3	11.94
2	7386.00	35.91 AV	54.00	18.09	1.00	221	23.97	38.51	8.73	35.3	11.94

Frequency(MHz):			2462			Polarity:			VERTICAL		
No.	Frequency (MHz)	Emission Level (dBuV/m)	Limit (dBuV/m)	Margin (dB)	Antenna Height (m)	Table Angle (Degree)	Raw Value (dBuV)	Antenna Factor (dB/m)	Cable Factor (dB)	Pre-amplifier (dB)	Correction Factor (dB/m)
1	4924.00	51.72 PK	74.00	22.28	1.00	191	48.52	31.58	7.82	36.2	3.20
1	4924.00	42.23 AV	54.00	11.77	1.00	191	39.03	31.58	7.82	36.2	3.20
2	7386.00	45.13 PK	74.00	28.87	1.00	191	33.19	38.51	8.73	35.3	11.94
2	7386.00	34.46 AV	54.00	19.54	1.00	191	22.52	38.51	8.73	35.3	11.94

BT4.0 Mode (above 1GHz)

Frequency(MHz):				2402			Polarity:			HORIZONTAL		
No.	Frequency (MHz)	Emission Level (dBuV/m)		Limit (dBuV/m)	Margin (dB)	Antenna Height (m)	Table Angle (Degree)	Raw Value (dBuV)	Antenna Factor (dB/m)	Cable Factor (dB)	Pre-amplifier (dB)	Correction Factor (dB/m)
1	4804.00	45.21	PK	74.00	28.79	1.00	120	43.31	31.42	6.98	36.5	1.90
1	4804.00	34.40	AV	54.00	19.60	1.00	120	32.5	31.42	6.98	36.5	1.90
2	7206.00	37.03	PK	74.00	36.97	1.00	120	26.43	37.03	8.87	35.3	10.60
2	7206.00	--	AV	--	--	--	--	--	--	--	--	--

Frequency(MHz):				2402			Polarity:			VERTICAL		
No.	Frequency (MHz)	Emission Level (dBuV/m)		Limit (dBuV/m)	Margin (dB)	Antenna Height (m)	Table Angle (Degree)	Raw Value (dBuV)	Antenna Factor (dB/m)	Cable Factor (dB)	Pre-amplifier (dB)	Correction Factor (dB/m)
1	4804.00	46.08	PK	74.00	27.92	1.00	165	44.18	31.42	6.98	36.5	1.90
1	4804.00	35.40	AV	54.00	18.60	1.00	165	33.50	31.42	6.98	36.5	1.90
2	7206.00	39.73	PK	74.00	34.27	1.00	165	29.13	37.03	8.87	35.3	10.60
2	7206.00	--	AV	--	--	--	--	--	--	--	--	--

Frequency(MHz):				2440			Polarity:			HORIZONTAL		
No.	Frequency (MHz)	Emission Level (dBuV/m)		Limit (dBuV/m)	Margin (dB)	Antenna Height (m)	Table Angle (Degree)	Raw Value (dBuV)	Antenna Factor (dB/m)	Cable Factor (dB)	Pre-amplifier (dB)	Correction Factor (dB/m)
1	4880.00	45.28	PK	74.00	28.72	1.00	165	43.22	30.98	7.58	36.5	2.06
1	4880.00	34.26	AV	54.00	19.74	1.00	165	32.20	30.98	7.58	36.5	2.06
2	7320.00	38.32	PK	74.00	35.68	1.00	165	27.40	37.66	8.56	35.3	10.92
2	7320.00	--	AV	--	--	--	--	--	--	--	--	--

Frequency(MHz):				2440			Polarity:			VERTICAL		
No.	Frequency (MHz)	Emission Level (dBuV/m)		Limit (dBuV/m)	Margin (dB)	Antenna Height (m)	Table Angle (Degree)	Raw Value (dBuV)	Antenna Factor (dB/m)	Cable Factor (dB)	Pre-amplifier (dB)	Correction Factor (dB/m)
1	4880.00	47.46	PK	74.00	26.54	1.00	173	45.4	30.98	7.58	36.5	2.06
1	4880.00	38.41	AV	54.00	15.59	1.00	173	36.35	30.98	7.58	36.5	2.06
2	7320.00	41.46	PK	74.00	32.54	1.00	173	30.54	37.66	8.56	35.3	10.92
2	7320.00	--	AV	--	--	--	--	--	--	--	--	--

Frequency(MHz):				2480			Polarity:			HORIZONTAL		
No.	Frequency (MHz)	Emission Level (dBuV/m)		Limit (dBuV/m)	Margin (dB)	Antenna Height (m)	Table Angle (Degree)	Raw Value (dBuV)	Antenna Factor (dB/m)	Cable Factor (dB)	Pre-amplifier (dB)	Correction Factor (dB/m)
1	4960.00	45.02	PK	74.00	28.98	1.00	120	41.95	31.47	7.80	36.2	3.07
1	4960.00	35.05	AV	54.00	18.95	1.00	120	31.98	31.47	7.80	36.2	3.07
2	7340.00	38.16	PK	74.00	35.84	1.00	120	26.42	38.32	8.72	35.3	11.74
2	7340.00	--	AV	--	--	--	--	--	--	--	--	--

Frequency(MHz):				2480			Polarity:			VERTICAL		
No.	Frequency (MHz)	Emission Level (dBuV/m)		Limit (dBuV/m)	Margin (dB)	Antenna Height (m)	Table Angle (Degree)	Raw Value (dBuV)	Antenna Factor (dB/m)	Cable Factor (dB)	Pre-amplifier (dB)	Correction Factor (dB/m)
1	4960.00	47.29	PK	74.00	26.71	1.00	165	44.22	31.47	7.80	36.2	3.07
1	4960.00	38.40	AV	54.00	15.60	1.00	165	35.33	31.47	7.80	36.2	3.07
2	7340.00	41.21	PK	74.00	32.79	1.00	165	29.47	38.32	8.72	35.3	11.74
2	7340.00	--	AV	--	--	--	--	--	--	--	--	--

REMARKS:

1. Emission level (dBUV/m) = Raw Value (dBUV) + Correction Factor (dB/m)
2. Correction Factor (dB/m) = Antenna Factor (dB/m) + Cable Factor (dB) - Pre-amplifier Factor
3. Margin value = Limit value - Emission level.
4. -- Mean the PK detector measured value is below average limit.
5. The other emission levels were very low against the limit.

3.3. Maximum Conducted Output Power

Limit

30dBm for digital modulation systems.

Test Procedure

For Peak Conducted Power

- For WiFi Test
 1. Remove the antenna from the EUT and then connect a low loss RF cable from the antenna port to the Power Meter.
 2. Ensure EUT transmitting with a duty cycle $\geq 98\%$.
 3. Record the value of Power Meter.
- For BT 4.0 Test
 1. Set the RBW $\geq DTS$ bandwidth
 2. Set VBW $\geq 3 \times$ RBW.
 3. Set span $\geq 3 \times$ RBW
 4. Sweep time = auto couple.
 5. Detector = peak.
 6. Trace mode = max hold.
 7. Allow trace to fully stabilize.
 8. Use peak marker function to determine the peak amplitude level

Test Configuration

- For WiFi Test

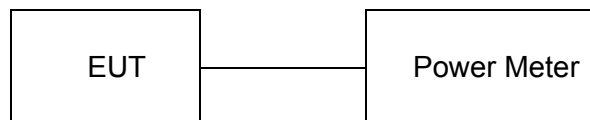

- For BT 4.0 Test

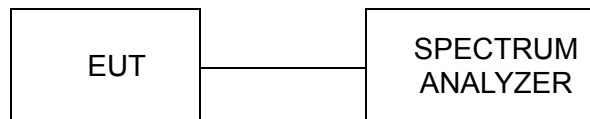

Test Results

WIFI

Type	Channel	Output power PK(dBm)	Limit (dBm)	Result
802.11b	01	14.32	30.00	Pass
	06	14.10		
	11	14.03		
802.11g	01	15.23	30.00	Pass
	06	15.14		
	11	15.32		
802.11n(H20)	01	15.31	30.00	Pass
	06	15.22		
	11	15.19		

Note: 1.The test results including the cable lose.

BT4.0

Type	Channel	Output power PK(dBm)	Limit (dBm)	Result
GFSK	00	1.27	30.00	Pass
	19	1.90		
	39	2.86		

Note: The test results including the cable loss.

3.4. Power Spectral Density

Limit

For digitally modulated systems, the power spectral density conducted from the intentional radiator to the antenna shall not be greater than 8 dBm in any 3 kHz band during any time interval of continuous transmission.

Test Procedure

1. This procedure shall be used if maximum peak conducted output power was used to demonstrate compliance to the output power limit.
 - a) Set analyzer center frequency to DTS channel center frequency.
 - b) Set the span to 1.5 times the DTS bandwidth.
 - c) Set the RBW to: $3 \text{ kHz} \leq \text{RBW} \leq 100 \text{ kHz}$.
 - d) Set the VBW $\geq 3 \times \text{RBW}$.
 - e) Detector = peak.
 - f) Sweep time = auto couple.
 - g) Trace mode = max hold.
 - h) Allow trace to fully stabilize.
 - i) Use the peak marker function to determine the maximum amplitude level within the RBW.
 - j) If measured value exceeds limit, reduce RBW (no less than 3 kHz) and repeat

Test Configuration

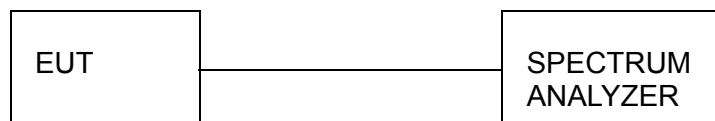

Test Results

WIFI

Type	Channel	Power Spectral Density (dBm/30KHz)	Limit (dBm/3KHz)	Result
802.11b	01	-0.80	8.00	Pass
	06	-0.52		
	11	-1.00		
802.11g	01	-2.43	8.00	Pass
	06	-3.01		
	11	-3.95		
802.11n(HT20)	01	-2.14	8.00	Pass
	06	-2.42		
	11	-3.57		

BT4.0

Type	Channel	Power Spectral Density (dBm/30KHz)	Limit (dBm/3KHz)	Result
BT4.0	00	-1.67	8.00	Pass
	19	-1.09		
	39	-0.33		

Test plot as follows:

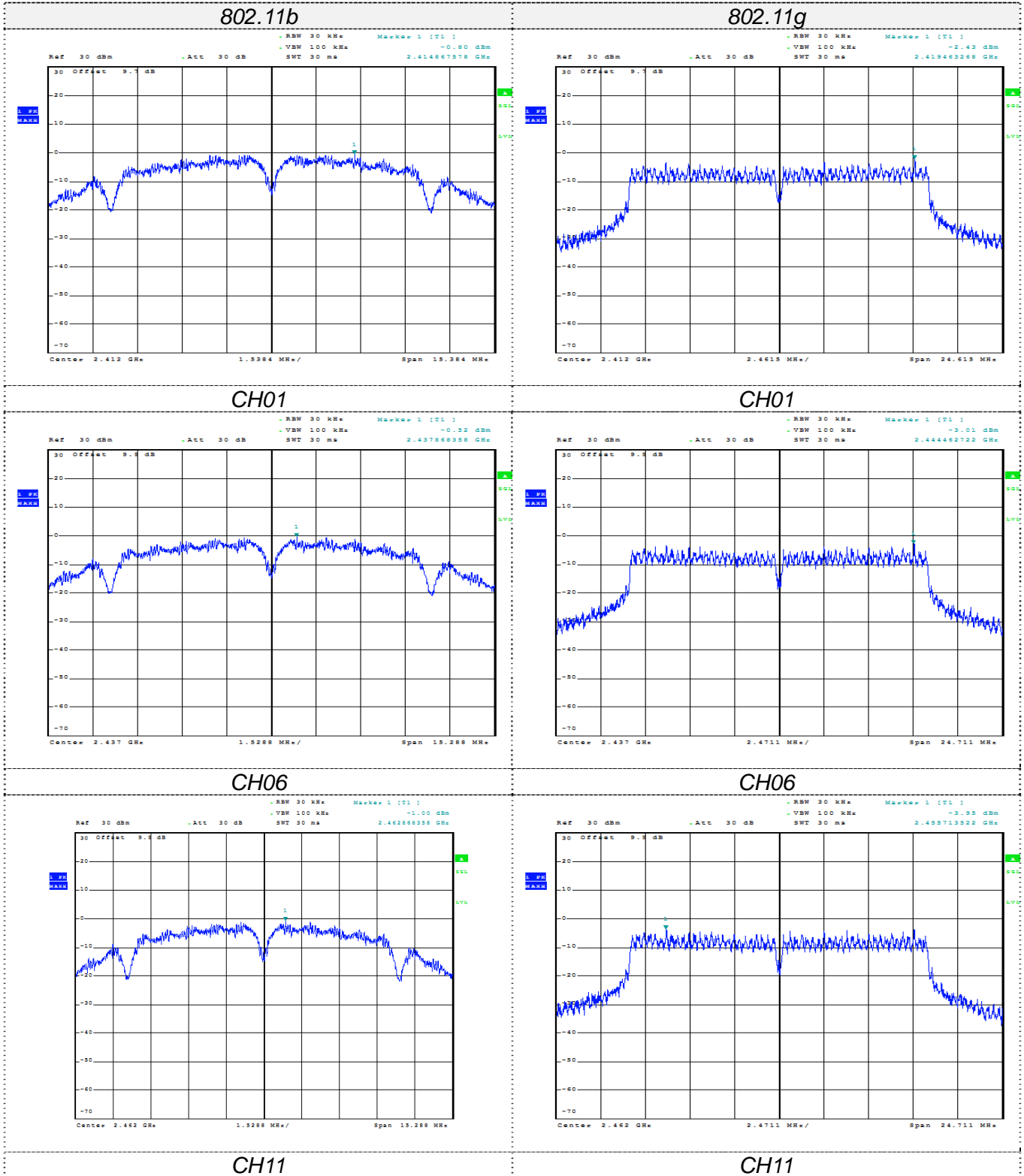

802.11n(HT20)

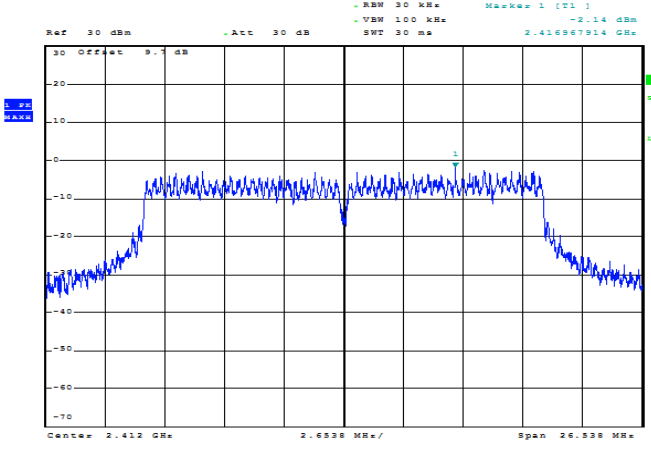

CH01

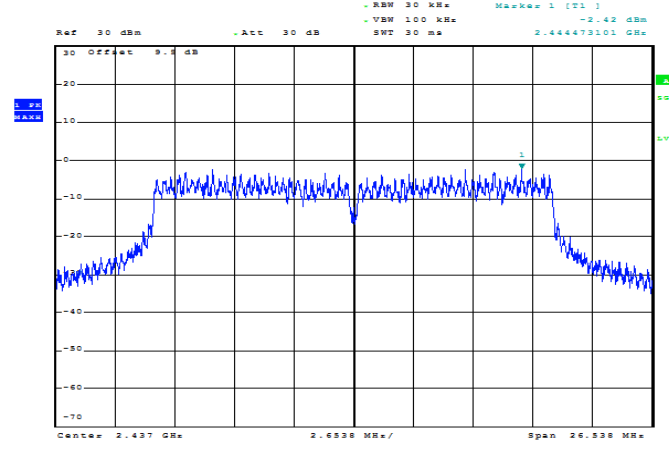

CH06

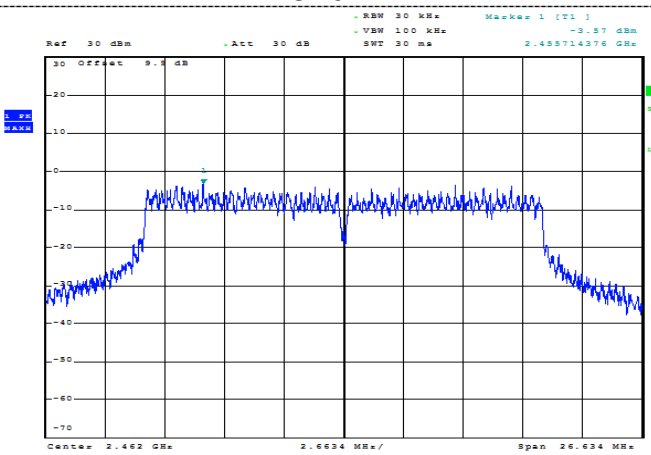

CH011

BT4.0

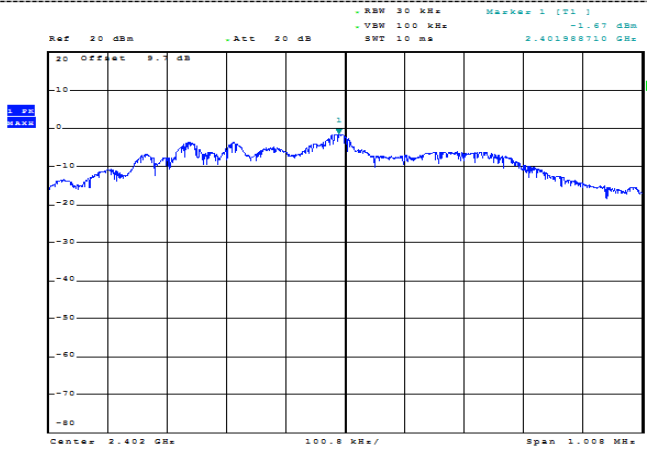

CH00

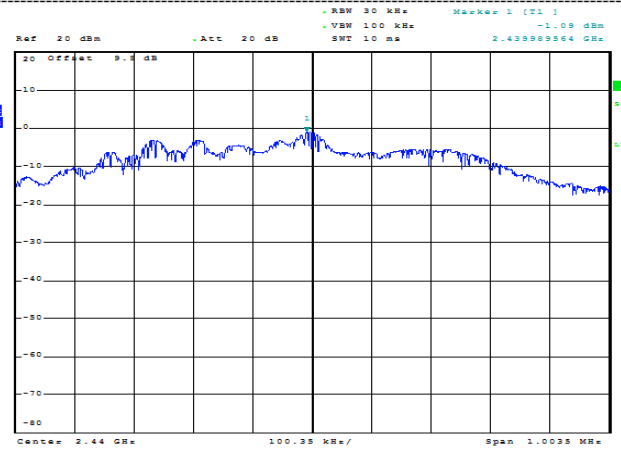

CH19

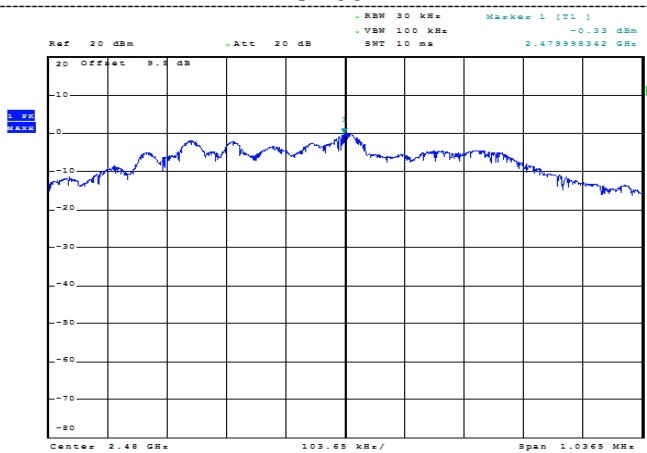

CH39

3.5. 6dB Bandwidth

Limit

For digital modulation systems, the minimum 6 dB bandwidth shall be at least 500 kHz

Test Procedure

1. The transmitter output was connected to the spectrum analyzer.
2. Set SA as follow:
 - a) RBW: 100 kHz.
 - b) VBW: $\geq 3 \times$ RBW.
 - c) Detector: Peak.
 - d) Trace mode: max hold.
 - e) Sweep: auto couple.
3. Allow the trace to stabilize.
4. Measure the maximum width of the emission that is constrained by the frequencies associated with the two outermost amplitude points (upper and lower frequencies) that are attenuated by 6 dB relative to the maximum level measured in the fundamental emission.

Test Configuration

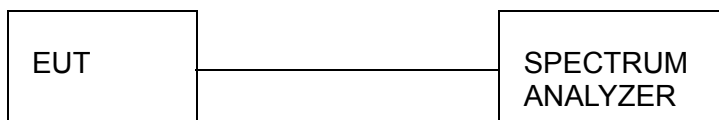

Test Results

WIFI

Type	Channel	6dB Bandwidth (MHz)	99% OBW (MHz)	Limit (KHz)	Result
802.11b	01	10.256	15.256	≥500	Pass
	06	10.192	15.641		
	11	10.192	15.000		
802.11g	01	16.410	16.859	≥500	Pass
	06	16.474	16.987		
	11	16.474	16.859		
802.11n(HT20)	01	17.692	19.167	≥500	Pass
	06	17.692	18.974		
	11	17.756	18.462		

BT4.0

Type	Channel	6dB Bandwidth (MHz)	99% OBW (MHz)	Limit (KHz)	Result
GFSK	00	0.672	1.059	≥500	Pass
	19	0.669	1.056		
	39	0.691	1.062		

Test plot as follows:

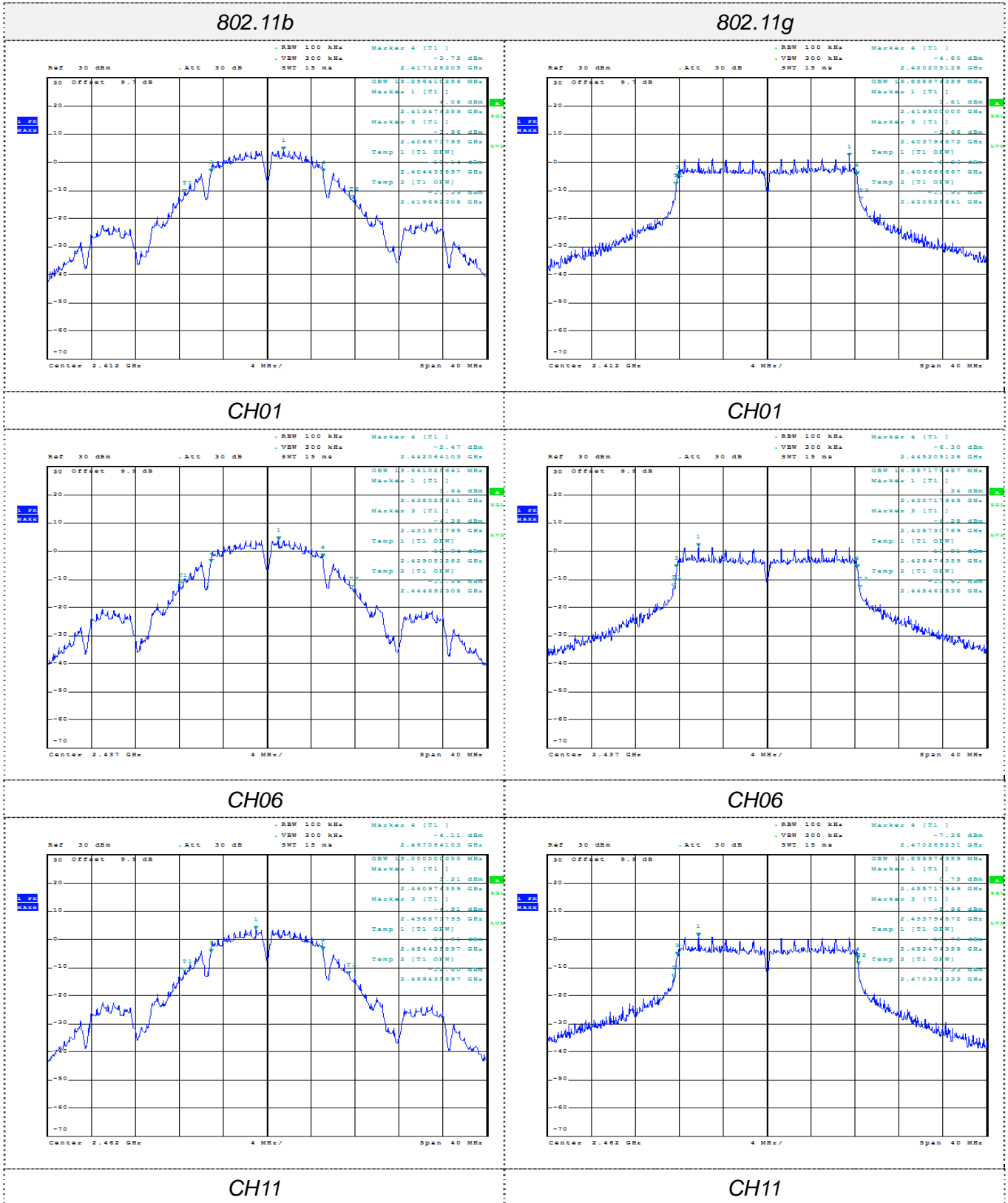

802.11n(HT20)

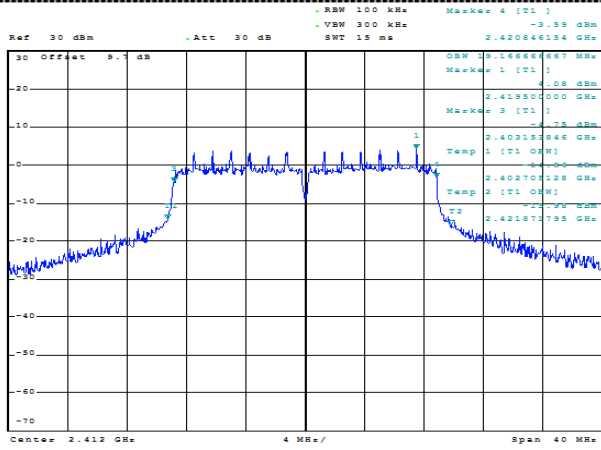

CH01

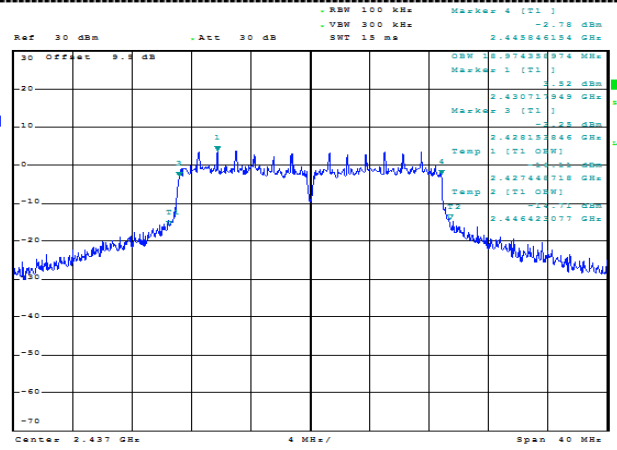

CH06

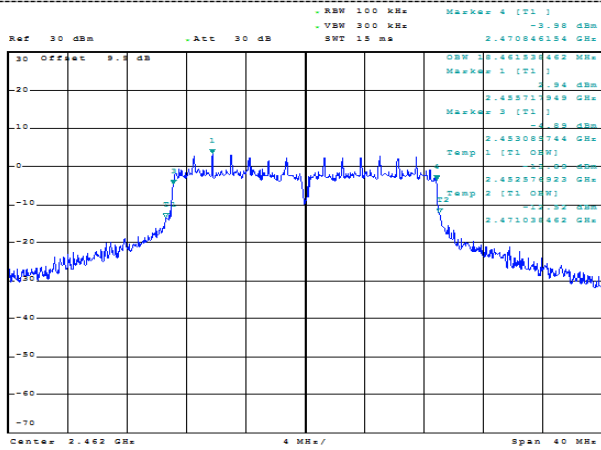

CH11

BT4.0

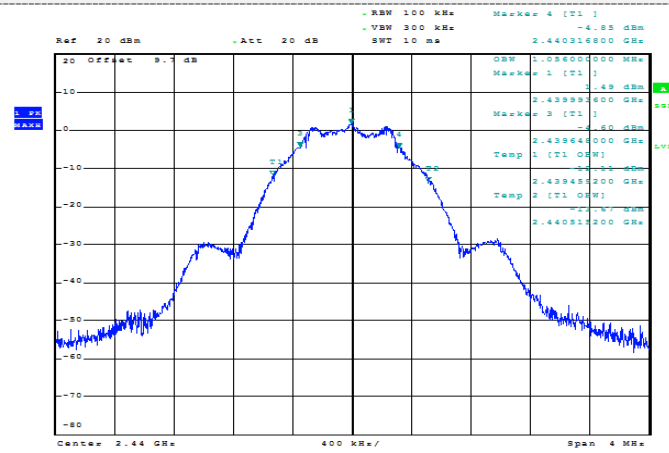
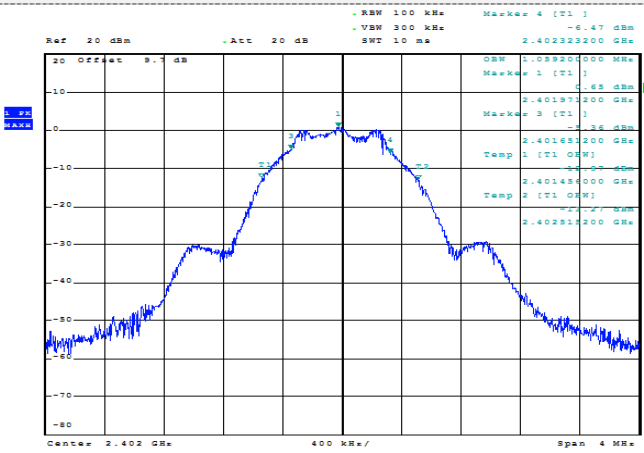

CH00

CH19

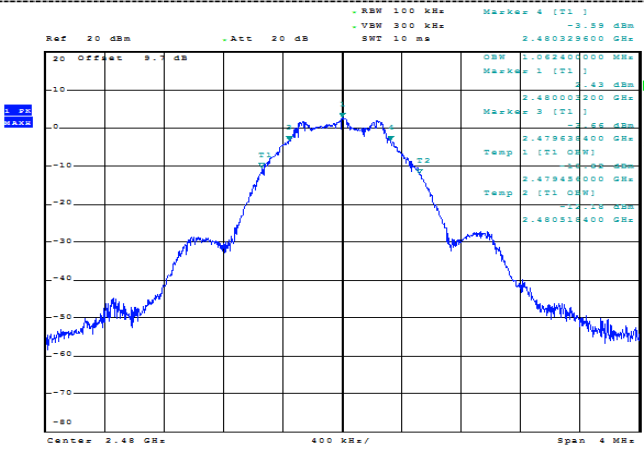

CH39

3.6. Band Edge Compliance of RF Emission

Limit

In any 100 kHz bandwidth outside the frequency band in which the spread spectrum or digitally modulated intentional radiator is operating, the radio frequency power that is produced by the intentional radiator shall be at least 20 dB below that in the 100 kHz bandwidth within the band that contains the highest level of the desired power, based on either an RF conducted or a radiated measurement, provided the transmitter demonstrates compliance with the peak conducted power limits. If the transmitter complies with the conducted power limits based on the use of RMS averaging over a time interval, as permitted under paragraph (b)(3) of this section, the attenuation required under this paragraph shall be 30 dB instead of 20 dB. Attenuation below the general limits specified in §15.209(a) is not required. In addition, radiated emissions which fall in the restricted bands, as defined in §15.205(a), must also comply with the radiated emission limits specified in §15.209(a) (see §15.205(c)).

Radiated emissions which fall in the restricted bands, as defined in § 15.205(a), must also comply with the radiated emission limits specified in § 15.209(a)

Test Procedure

Test Procedure for conducted method

- This procedure shall be used if maximum peak conducted output power was used to demonstrate compliance to the output power limit.
 1. Remove the antenna from the EUT and then connect to a low loss RF cable from the antenna port to a spectrum analyzer
 2. Turn on the EUT and make it operate in transmitting mode. Then set it to Low Channel and High Channel within its operating range, and make sure the instrument is operated in its linear range.
 3. Set spectrum analyzer RBW =100 kHz, VBW=300 kHz, Detector=peak, Sweep time=Auto, trace=maxhold
 4. Marker the highest point which fall into restricted frequency bands
 5. Repeat above procedures until all measured frequencies were complete.

Test Procedure tor radiated method

1. The EUT was placed on the top of a rotating table 0.8 meters above the ground at a 3 meter anechoic chamber. The table was rotated 360 degrees to determine the position of the highest radiation.
2. The EUT was set 3 meters away from the interference receiving antenna, which was mounted on the top of a variable height antenna tower.
3. The antenna height is varied from one meter to four meters above the ground to determine the maximum value of the field strength. Both horizontal and vertical polarizations of the antenna are set to make the measurement.
4. For each suspected emission, the EUT was arranged to its worst case and then the antenna was tuned to heights from 1 meter to 4 meters and the rotatable table was turned from 0 degrees to 360 degrees to find the maximum reading.
5. The test-receiver system was set to Peak Detect Function and Specified Bandwidth with Maximum Hold Mode.
6. Place a marker at the end of the restricted band closest to the transmit frequency to show compliance. Also measure any emissions in the restricted bands. Save the spectrum analyzer plot. Repeat for each power and modulation for lowest and highest channel
7. Test the EUT in the lowest channel, the highest channel
8. The radiation measurements are performed in X, Y, Z axis positioning. And found the X axis positioning which it is worse case, only the test worst case mode is recorded in the report.
9. Repeat above procedures until all frequencies measured was complete.

Test Results

A. Conducted measurements

802.11b			
Frequency (MHz)	Delta Peak to Band emission (dBc)	Limit (dBc)	Verdict
2386.733	45.676	20	PASS
2483.505	44.866	20	PASS

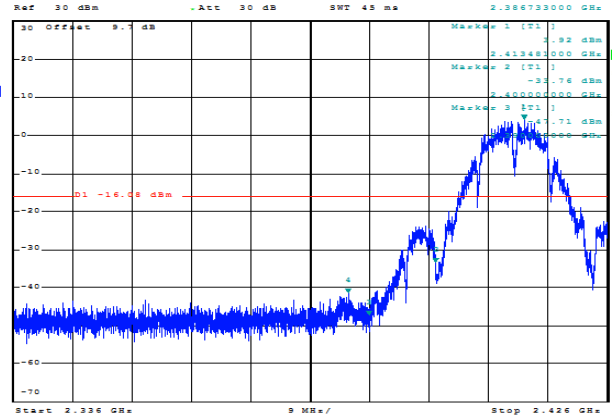
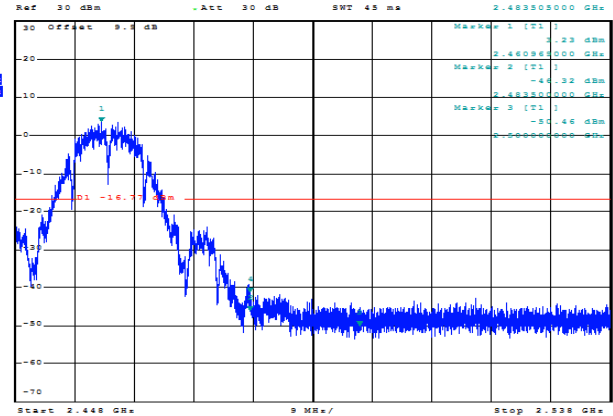
	
2412	2462

802.11g			
Frequency (MHz)	Delta Peak to Band emission (dBc)	Limit (dBc)	Verdict
2389.505	39.206	20	PASS
2483.532	40.258	20	PASS

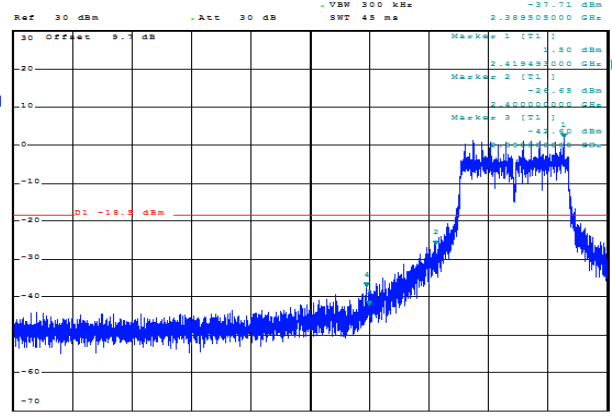
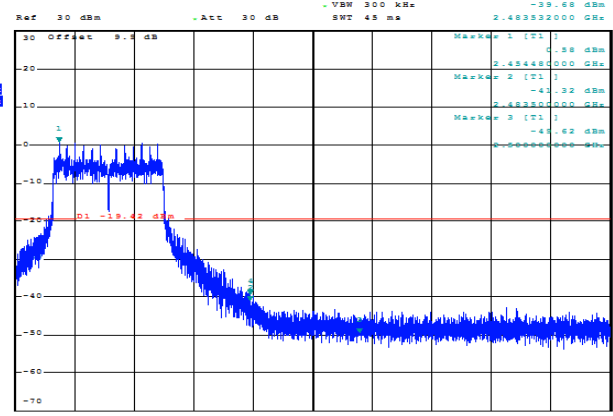
	
2412	2462

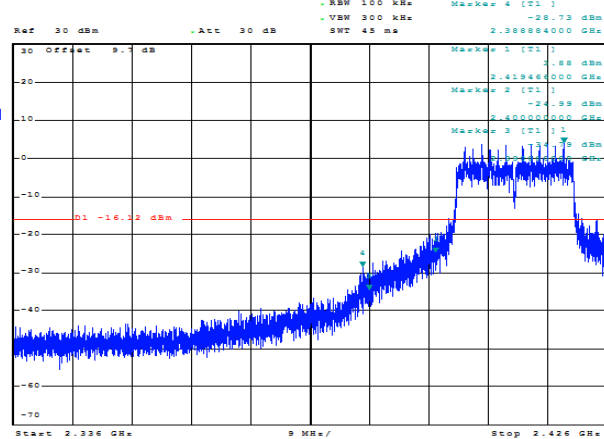
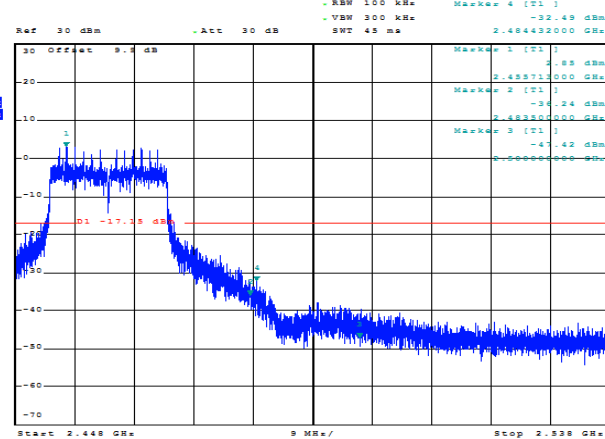
802.11n20			
Frequency (MHz)	Delta Peak to Band emission (dBc)	Limit (dBc)	Verdict
2388.884	32.614	20	PASS
2484.432	35.337	20	PASS
			
2412		2462	

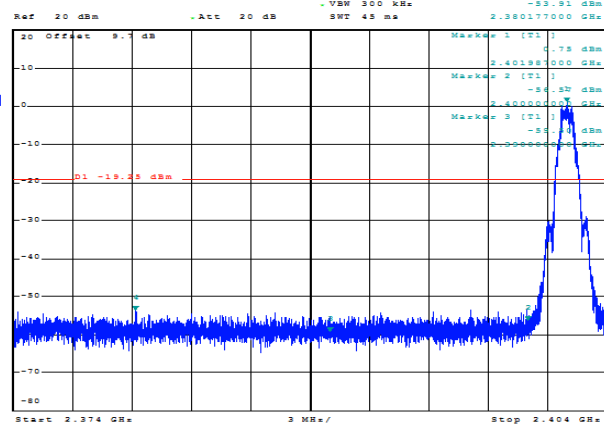
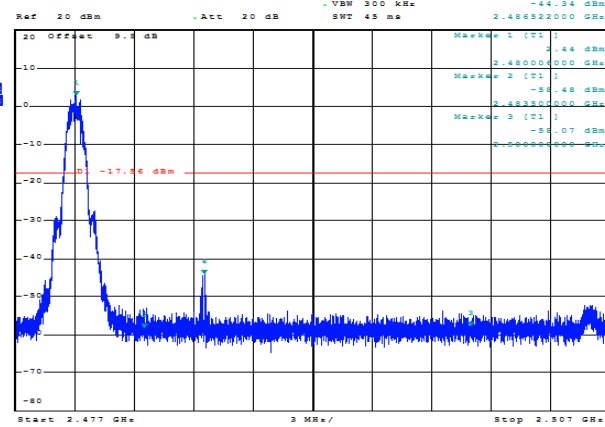
BT4.0			
Frequency (MHz)	Delta Peak to Band emission (dBc)	Limit (dBc)	Verdict
2380.177	54.657	20	PASS
2486.522	46.781	20	PASS
			
2402		2480	

B. Radiated measurements

802.11b

Frequency(MHz):			2412			Polarity:			HORIZONTAL		
Frequency (MHz)	Emission Level (dBuV/m)		Limit (dBuV/m)	Margin (dB)	Antenna Height (m)	Table Angle (Degree)	Raw Value (dBuV)	Antenna Factor (dB/m)	Cable Factor (dB)	Pre-amplifier (dB)	Correction Factor (dB/m)
2390.00	52.41	PK	74.00	21.59	1.00	52	57.72	27.49	3.32	36.12	-5.31
2390.00	43.76	AV	54.00	10.24	1.00	52	49.07	27.49	3.32	36.12	-5.31
Frequency(MHz):			2412			Polarity:			VERTICAL		
Frequency (MHz)	Emission Level (dBuV/m)		Limit (dBuV/m)	Margin (dB)	Antenna Height (m)	Table Angle (Degree)	Raw Value (dBuV)	Antenna Factor (dB/m)	Cable Factor (dB)	Pre-amplifier (dB)	Correction Factor (dB/m)
2390.00	51.89	PK	74.00	22.11	1.00	204	57.20	27.49	3.32	36.12	-5.31
2390.00	41.39	AV	54.00	12.61	1.00	204	46.70	27.49	3.32	36.12	-5.31
Frequency(MHz):			2462			Polarity:			HORIZONTAL		
Frequency (MHz)	Emission Level (dBuV/m)		Limit (dBuV/m)	Margin (dB)	Antenna Height (m)	Table Angle (Degree)	Raw Value (dBuV)	Antenna Factor (dB/m)	Cable Factor (dB)	Pre-amplifier (dB)	Correction Factor (dB/m)
2483.50	51.42	PK	74.00	22.58	1.00	57	57.14	27.45	3.38	36.55	-5.72
2483.50	41.25	AV	54.00	12.75	1.00	57	46.97	27.45	3.38	36.55	-5.72
Frequency(MHz):			2462			Polarity:			VERTICAL		
Frequency (MHz)	Emission Level (dBuV/m)		Limit (dBuV/m)	Margin (dB)	Antenna Height (m)	Table Angle (Degree)	Raw Value (dBuV)	Antenna Factor (dB/m)	Cable Factor (dB)	Pre-amplifier (dB)	Correction Factor (dB/m)
2483.50	51.50	PK	74.00	22.50	1.00	194	57.22	27.45	3.38	36.55	-5.72
2483.50	41.52	AV	54.00	12.48	1.00	194	47.24	27.45	3.38	36.55	-5.72

802.11g

Frequency(MHz):			2412			Polarity:			HORIZONTAL		
Frequency (MHz)	Emission Level (dBuV/m)		Limit (dBuV/m)	Margin (dB)	Antenna Height (m)	Table Angle (Degree)	Raw Value (dBuV)	Antenna Factor (dB/m)	Cable Factor (dB)	Pre-amplifier (dB)	Correction Factor (dB/m)
2390.00	50.26	PK	74.00	23.74	1.00	47	55.57	27.49	3.32	36.12	-5.31
2390.00	40.62	AV	54.00	13.38	1.00	47	45.93	27.49	3.32	36.12	-5.31
Frequency(MHz):			2412			Polarity:			VERTICAL		
Frequency (MHz)	Emission Level (dBuV/m)		Limit (dBuV/m)	Margin (dB)	Antenna Height (m)	Table Angle (Degree)	Raw Value (dBuV)	Antenna Factor (dB/m)	Cable Factor (dB)	Pre-amplifier (dB)	Correction Factor (dB/m)
2390.00	49.93	PK	74.00	24.07	1.00	199	55.24	27.49	3.32	36.12	-5.31
2390.00	42.33	AV	54.00	11.67	1.00	199	47.64	27.49	3.32	36.12	-5.31
Frequency(MHz):			2462			Polarity:			HORIZONTAL		
Frequency (MHz)	Emission Level (dBuV/m)		Limit (dBuV/m)	Margin (dB)	Antenna Height (m)	Table Angle (Degree)	Raw Value (dBuV)	Antenna Factor (dB/m)	Cable Factor (dB)	Pre-amplifier (dB)	Correction Factor (dB/m)
2483.50	52.33	PK	74.00	21.67	1.00	57	58.05	27.45	3.38	36.55	-5.72
2483.50	42.36	AV	54.00	11.64	1.00	57	48.08	27.45	3.38	36.55	-5.72
Frequency(MHz):			2462			Polarity:			VERTICAL		
Frequency (MHz)	Emission Level (dBuV/m)		Limit (dBuV/m)	Margin (dB)	Antenna Height (m)	Table Angle (Degree)	Raw Value (dBuV)	Antenna Factor (dB/m)	Cable Factor (dB)	Pre-amplifier (dB)	Correction Factor (dB/m)
2483.50	51.52	PK	74.00	22.48	1.00	214	57.24	27.45	3.38	36.55	-5.72
2483.50	40.72	AV	54.00	13.28	1.00	214	46.44	27.45	3.38	36.55	-5.72



802.11n20

Frequency(MHz):			2412			Polarity:			HORIZONTAL		
Frequency (MHz)	Emission Level (dBuV/m)		Limit (dBuV/m)	Margin (dB)	Antenna Height (m)	Table Angle (Degree)	Raw Value (dBuV)	Antenna Factor (dB/m)	Cable Factor (dB)	Pre-amplifier (dB)	Correction Factor (dB/m)
2390.00	52.40	PK	74.00	21.60	1.00	72	57.71	27.49	3.32	36.12	-5.31
2390.00	40.33	AV	54.00	13.67	1.00	72	45.64	27.49	3.32	36.12	-5.31
Frequency(MHz):			2412			Polarity:			VERTICAL		
Frequency (MHz)	Emission Level (dBuV/m)		Limit (dBuV/m)	Margin (dB)	Antenna Height (m)	Table Angle (Degree)	Raw Value (dBuV)	Antenna Factor (dB/m)	Cable Factor (dB)	Pre-amplifier (dB)	Correction Factor (dB/m)
2390.00	50.80	PK	74.00	23.20	1.00	216	56.11	27.49	3.32	36.12	-5.31
2390.00	42.31	AV	54.00	11.69	1.00	216	47.62	27.49	3.32	36.12	-5.31
Frequency(MHz):			2462			Polarity:			HORIZONTAL		
Frequency (MHz)	Emission Level (dBuV/m)		Limit (dBuV/m)	Margin (dB)	Antenna Height (m)	Table Angle (Degree)	Raw Value (dBuV)	Antenna Factor (dB/m)	Cable Factor (dB)	Pre-amplifier (dB)	Correction Factor (dB/m)
2483.50	52.48	PK	74.00	21.52	1.00	67	58.20	27.45	3.38	36.55	-5.72
2483.50	42.17	AV	54.00	11.83	1.00	67	47.89	27.45	3.38	36.55	-5.72
Frequency(MHz):			2462			Polarity:			VERTICAL		
Frequency (MHz)	Emission Level (dBuV/m)		Limit (dBuV/m)	Margin (dB)	Antenna Height (m)	Table Angle (Degree)	Raw Value (dBuV)	Antenna Factor (dB/m)	Cable Factor (dB)	Pre-amplifier (dB)	Correction Factor (dB/m)
2483.50	51.02	PK	74.00	22.98	1.00	224	56.74	27.45	3.38	36.55	-5.72
2483.50	40.53	AV	54.00	13.47	1.00	224	46.25	27.45	3.38	36.55	-5.72

bt 4.0 GFSK

Frequency(MHz):			2402			Polarity:			HORIZONTAL		
Frequency (MHz)	Emission Level (dBuV/m)		Limit (dBuV/m)	Margin (dB)	Antenna Height (m)	Table Angle (Degree)	Raw Value (dBuV)	Antenna Factor (dB/m)	Cable Factor (dB)	Pre-amplifier (dB)	Correction Factor (dB/m)
2390.00	49.09	PK	74.00	24.91	1.00	67	54.40	27.49	3.32	36.12	-5.31
2390.00	39.50	AV	54.00	14.50	1.00	67	44.81	27.49	3.32	36.12	-5.31
Frequency(MHz):			2402			Polarity:			VERTICAL		
Frequency (MHz)	Emission Level (dBuV/m)		Limit (dBuV/m)	Margin (dB)	Antenna Height (m)	Table Angle (Degree)	Raw Value (dBuV)	Antenna Factor (dB/m)	Cable Factor (dB)	Pre-amplifier (dB)	Correction Factor (dB/m)
2390.00	49.43	PK	74.00	24.57	1.00	189	54.74	27.49	3.32	36.12	-5.31
2390.00	37.65	AV	54.00	16.35	1.00	189	42.96	27.49	3.32	36.12	-5.31
Frequency(MHz):			2480			Polarity:			HORIZONTAL		
Frequency (MHz)	Emission Level (dBuV/m)		Limit (dBuV/m)	Margin (dB)	Antenna Height (m)	Table Angle (Degree)	Raw Value (dBuV)	Antenna Factor (dB/m)	Cable Factor (dB)	Pre-amplifier (dB)	Correction Factor (dB/m)
2483.50	48.41	PK	74.00	25.59	1.00	57	54.13	27.45	3.38	36.55	-5.72
2483.50	36.36	AV	54.00	17.64	1.00	57	42.08	27.45	3.38	36.55	-5.72
Frequency(MHz):			2480			Polarity:			VERTICAL		
Frequency (MHz)	Emission Level (dBuV/m)		Limit (dBuV/m)	Margin (dB)	Antenna Height (m)	Table Angle (Degree)	Raw Value (dBuV)	Antenna Factor (dB/m)	Cable Factor (dB)	Pre-amplifier (dB)	Correction Factor (dB/m)
2483.50	48.75	PK	74.00	25.25	1.00	220	54.47	27.45	3.38	36.55	-5.72
2483.50	37.26	AV	54.00	16.74	1.00	220	42.98	27.45	3.38	36.55	-5.72



REMARKS:

1. Emission level (dBUV/m) = Raw Value (dBUV) + Correction Factor (dB/m)
2. Correction Factor (dB/m) = Antenna Factor (dB/m) + Cable Factor (dB) - Pre-amplifier Factor
3. Margin value = Limit value - Emission level.
4. -- Mean the PK detector measured value is below average limit.
5. The other emission levels were very low against the limit.

3.7. Spurious RF Conducted Emission

Limit

1. Below -20dB of the highest emission level in operating band.
2. Fall in the restricted bands listed in section 15.205. The maximum permitted average field strength is listed in section 15.209.

Test Procedure

The transmitter output was connected to the spectrum analyzer through a low loss RF cable. Spurious RF Conducted Emission was measured by spectrum analyzer with 100 KHz RBW and 300KHz VBW, measurement frequency range from 30MHz to 26.5GHz.

Test Configuration



Test Results

Remark: The measurement frequency range is from 30MHz to the 10th harmonic of the fundamental frequency. The lowest, middle and highest channels are tested to verify the spurious emissions.

Test plot as follows:

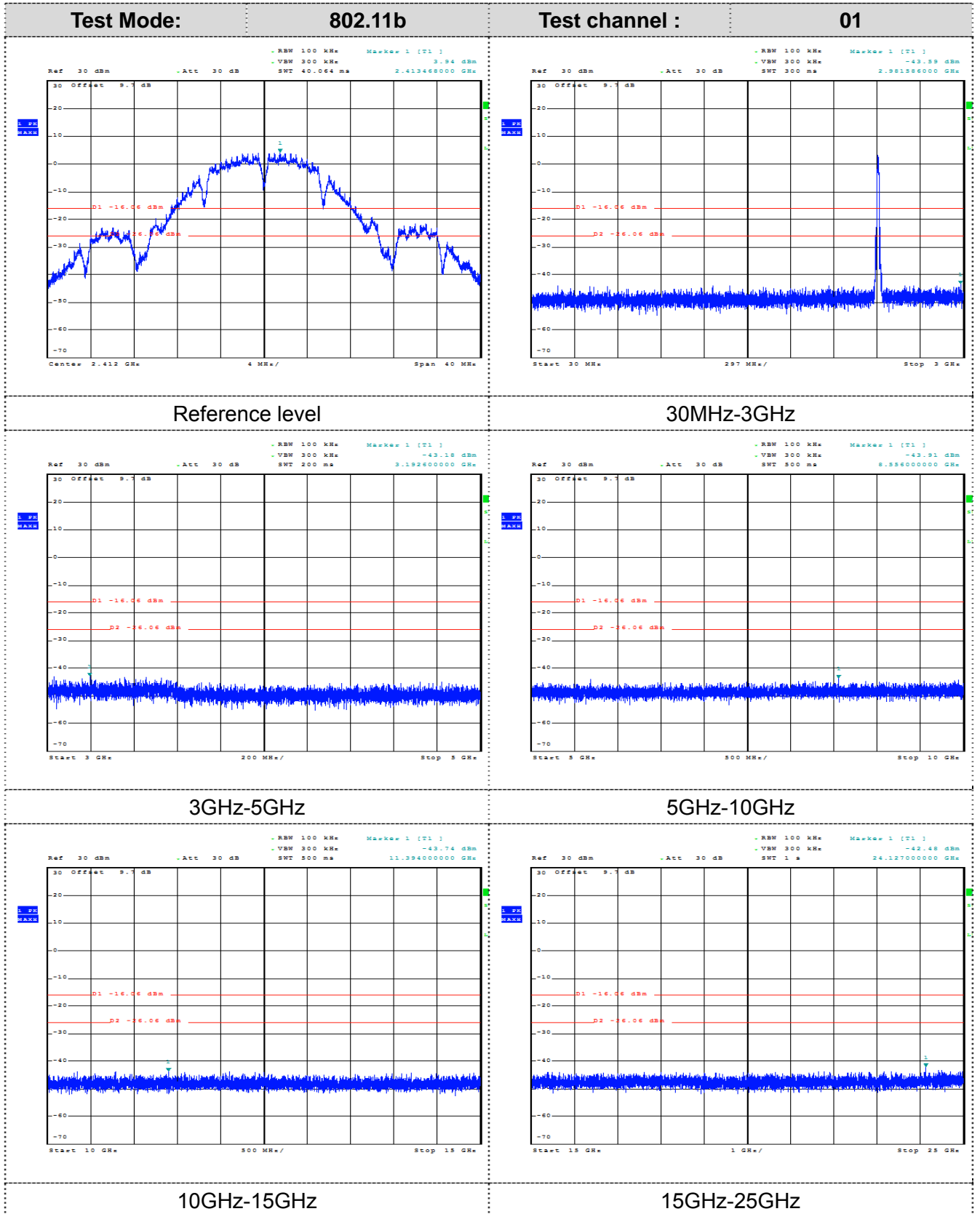

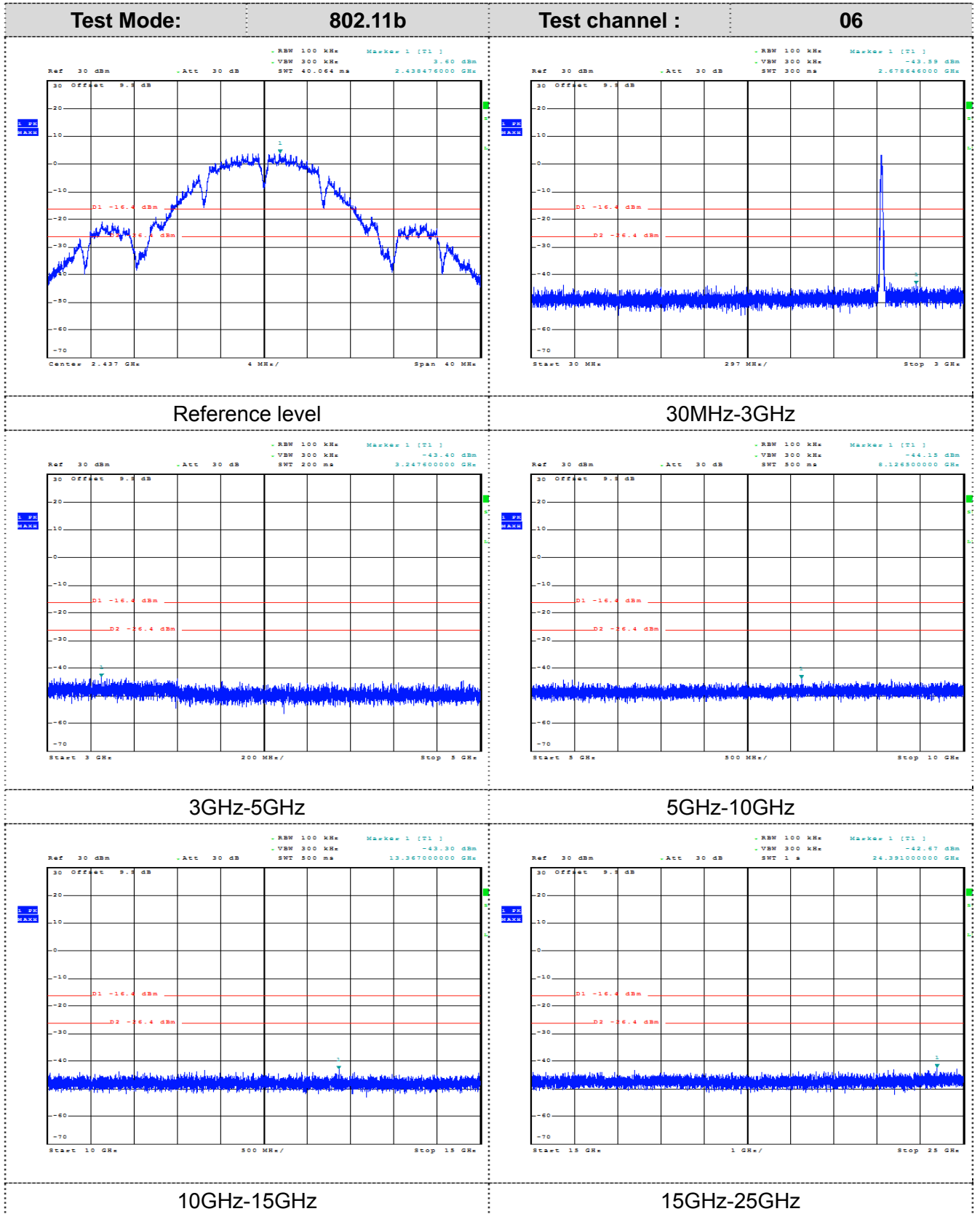

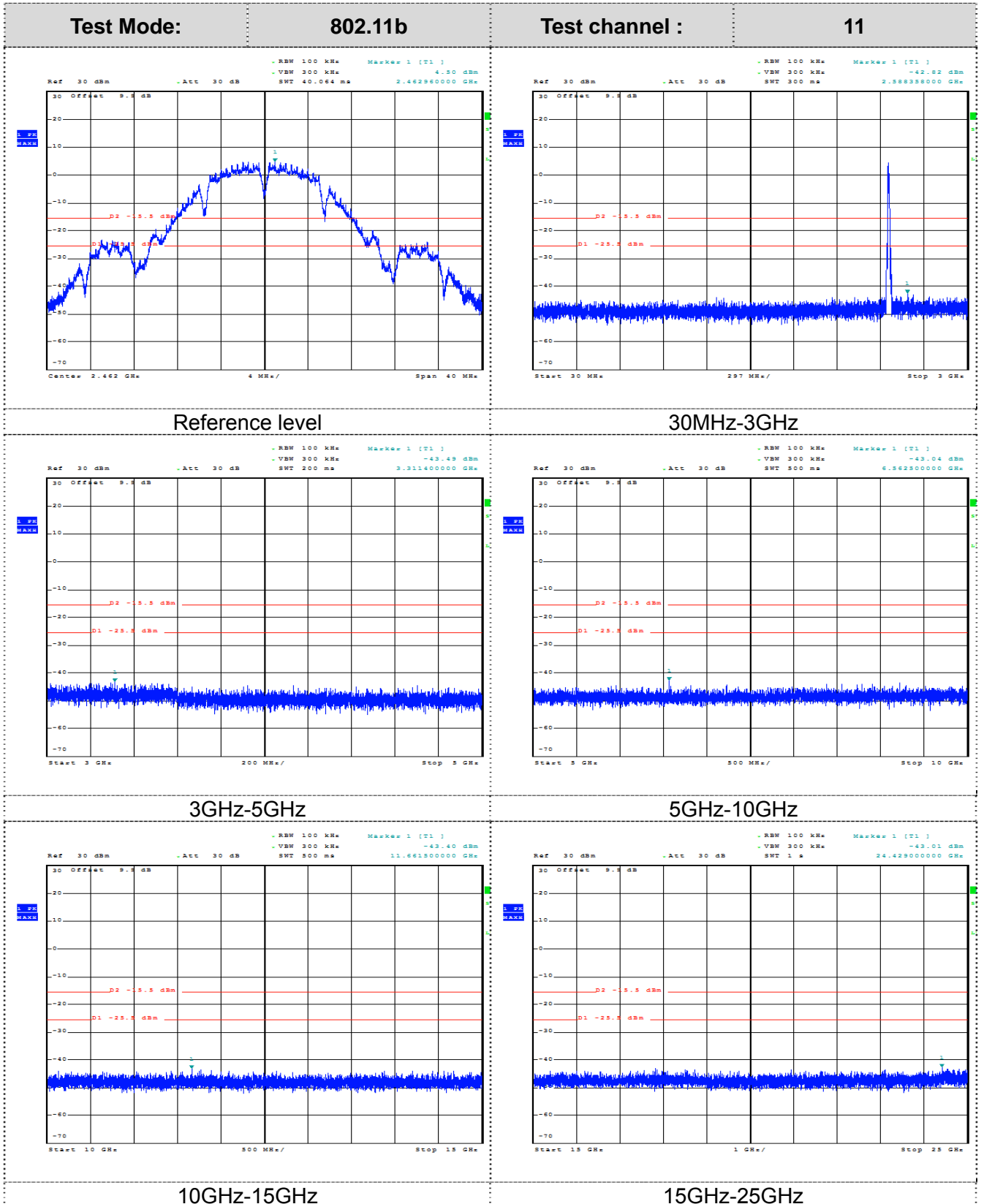

Test Mode:

802.11g

Test channel :

01

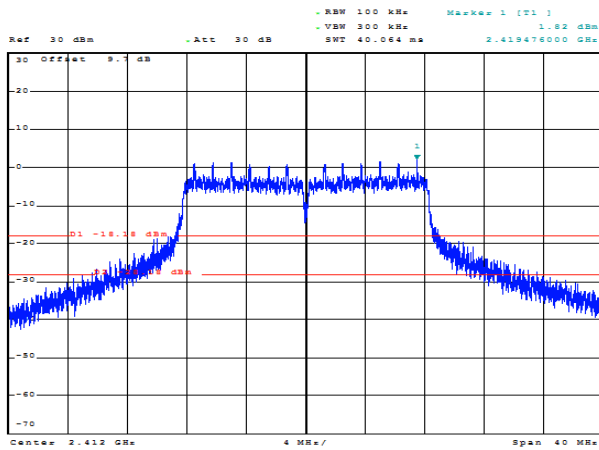

Reference level

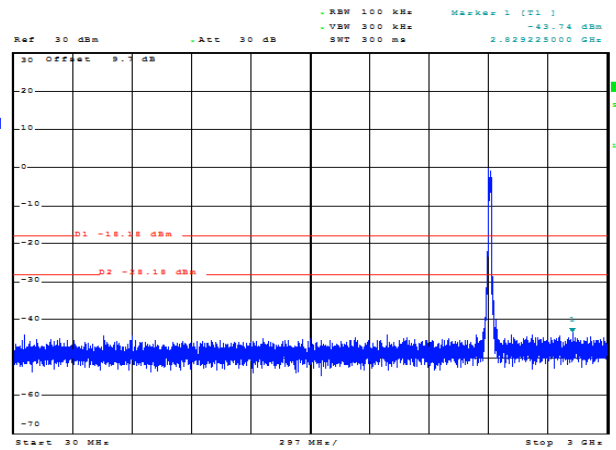

30MHz-3GHz

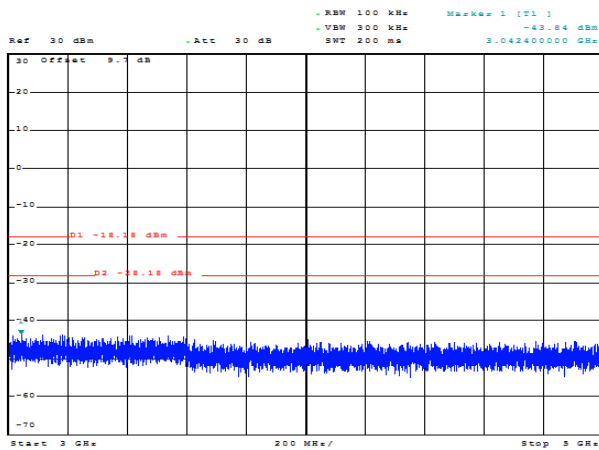

3GHz-5GHz

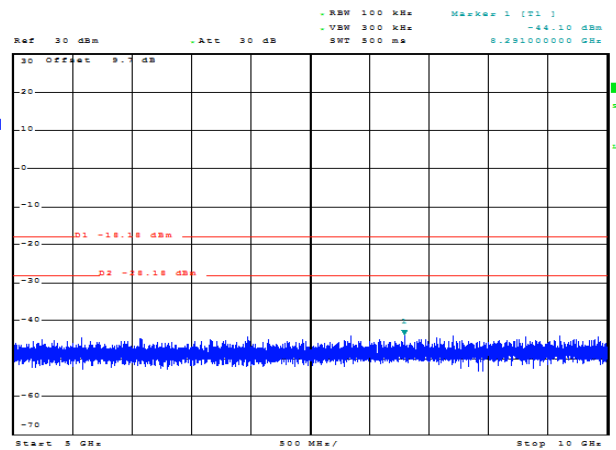

5GHz-10GHz

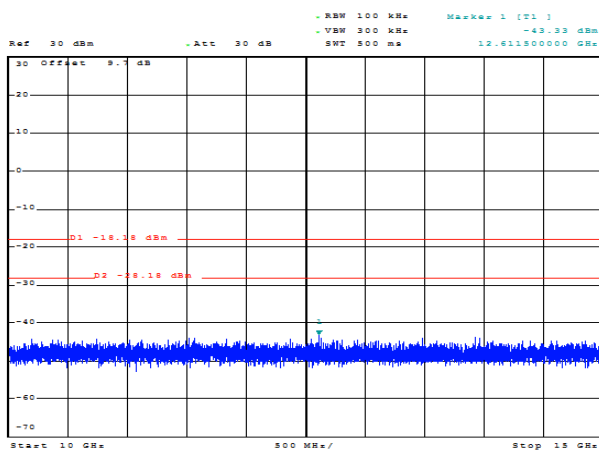

10GHz-15GHz

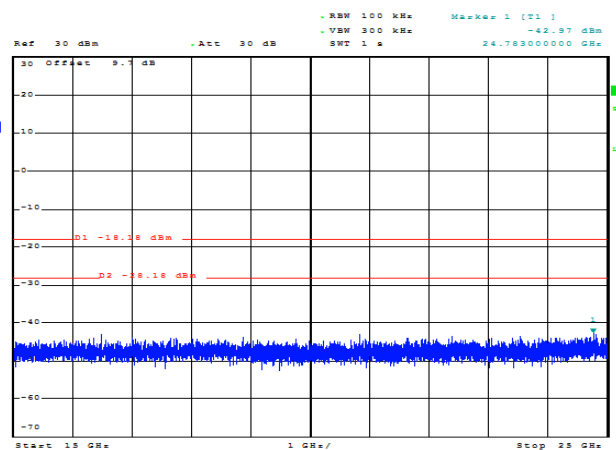

15GHz-25GHz

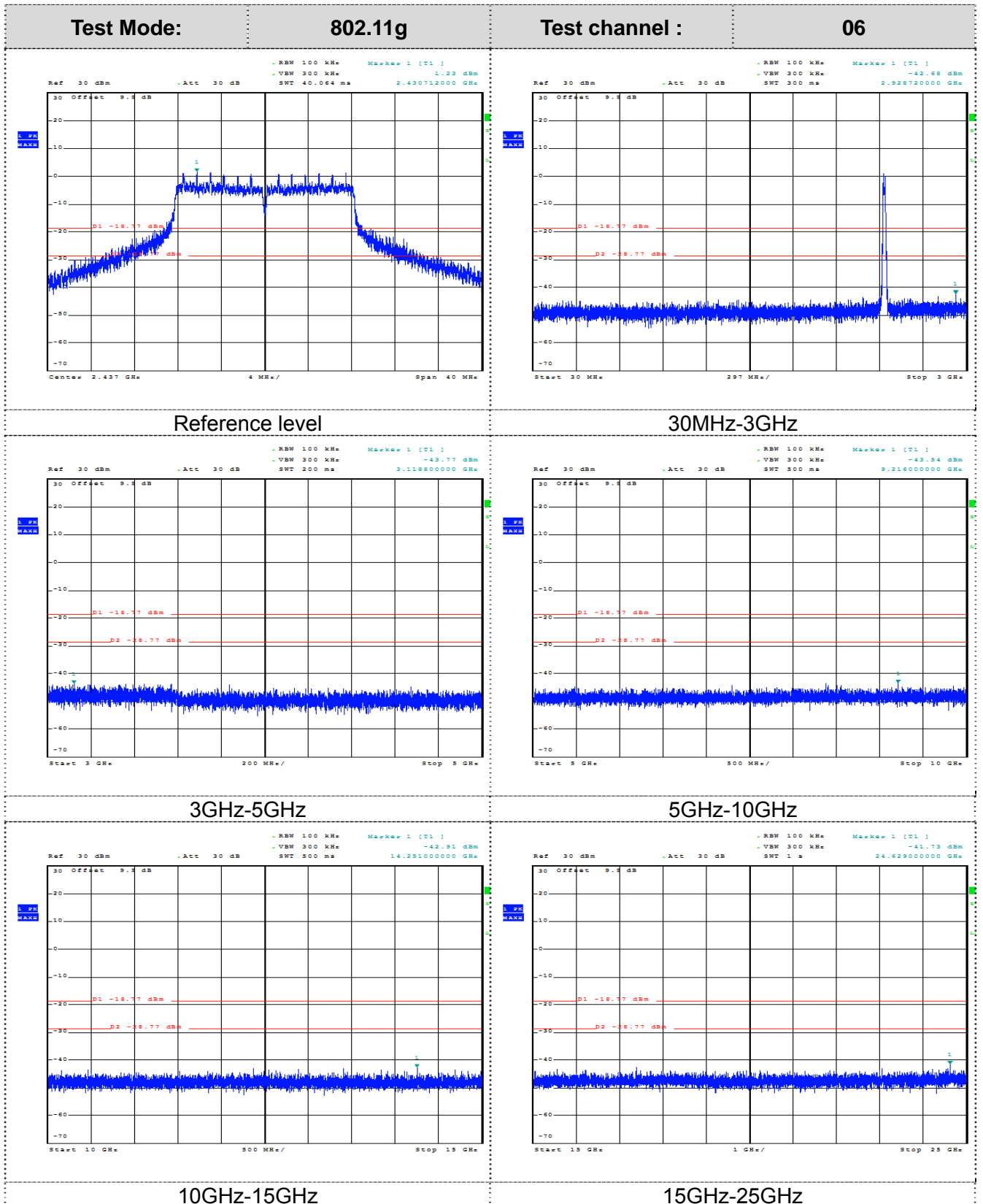

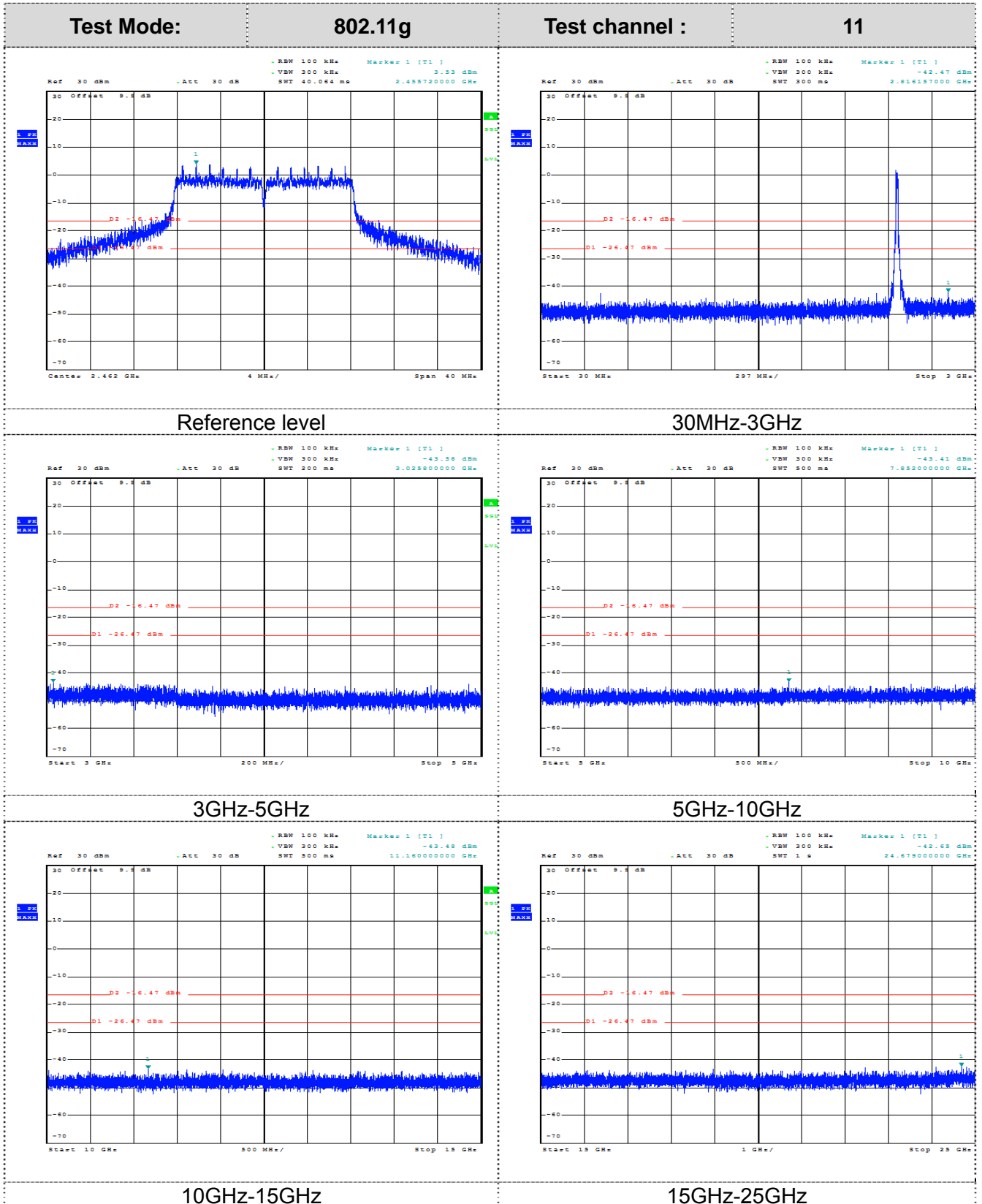

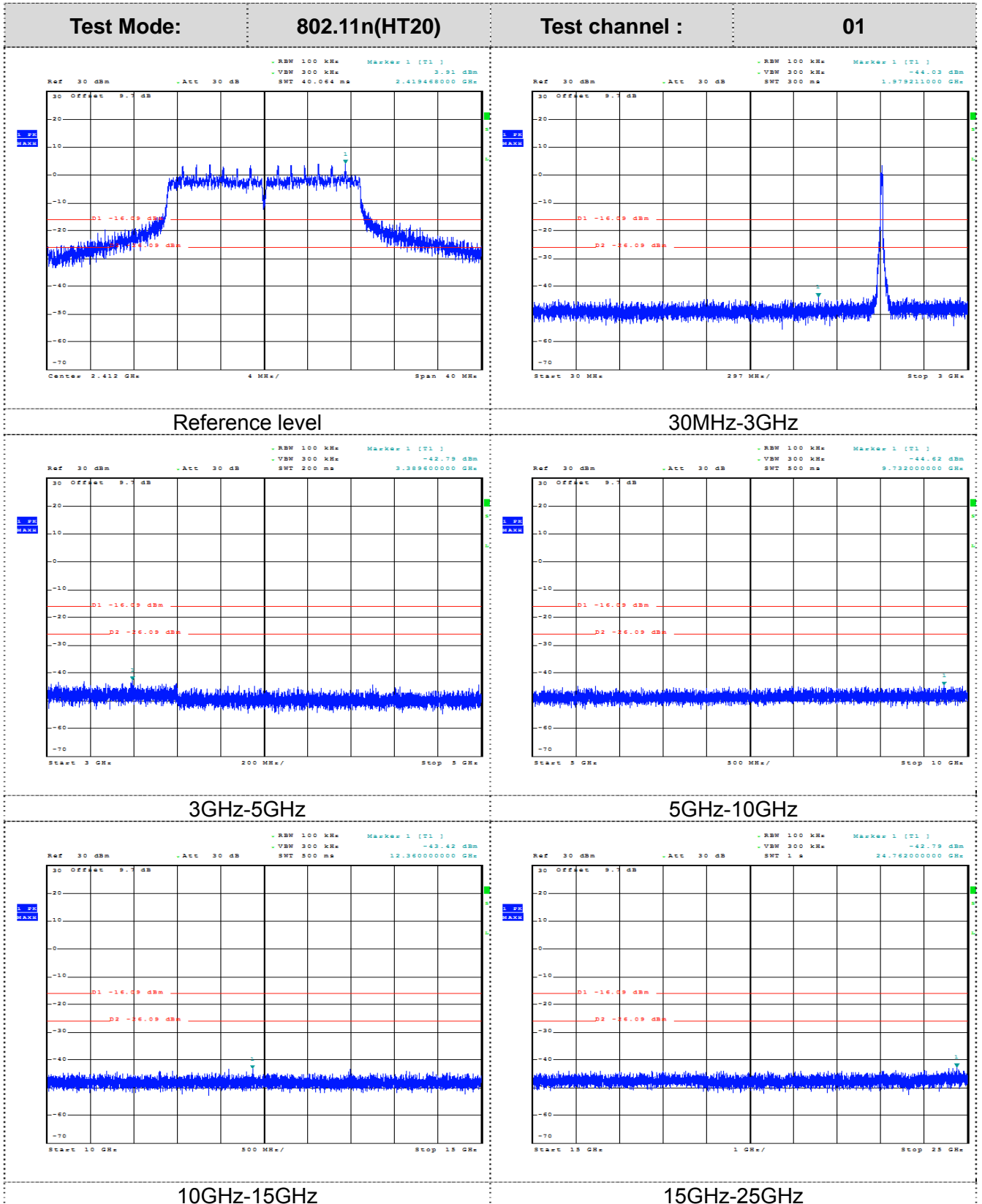

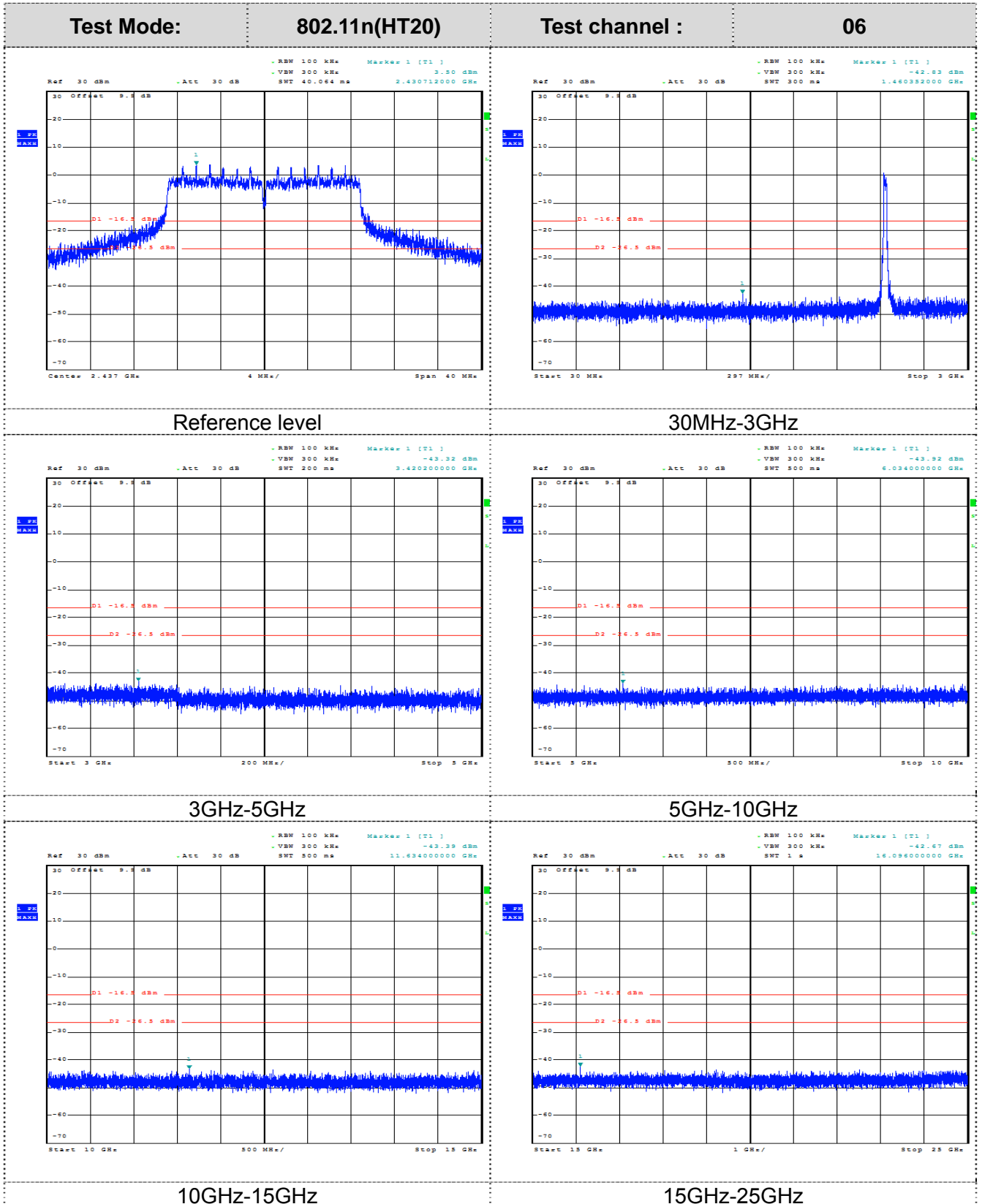

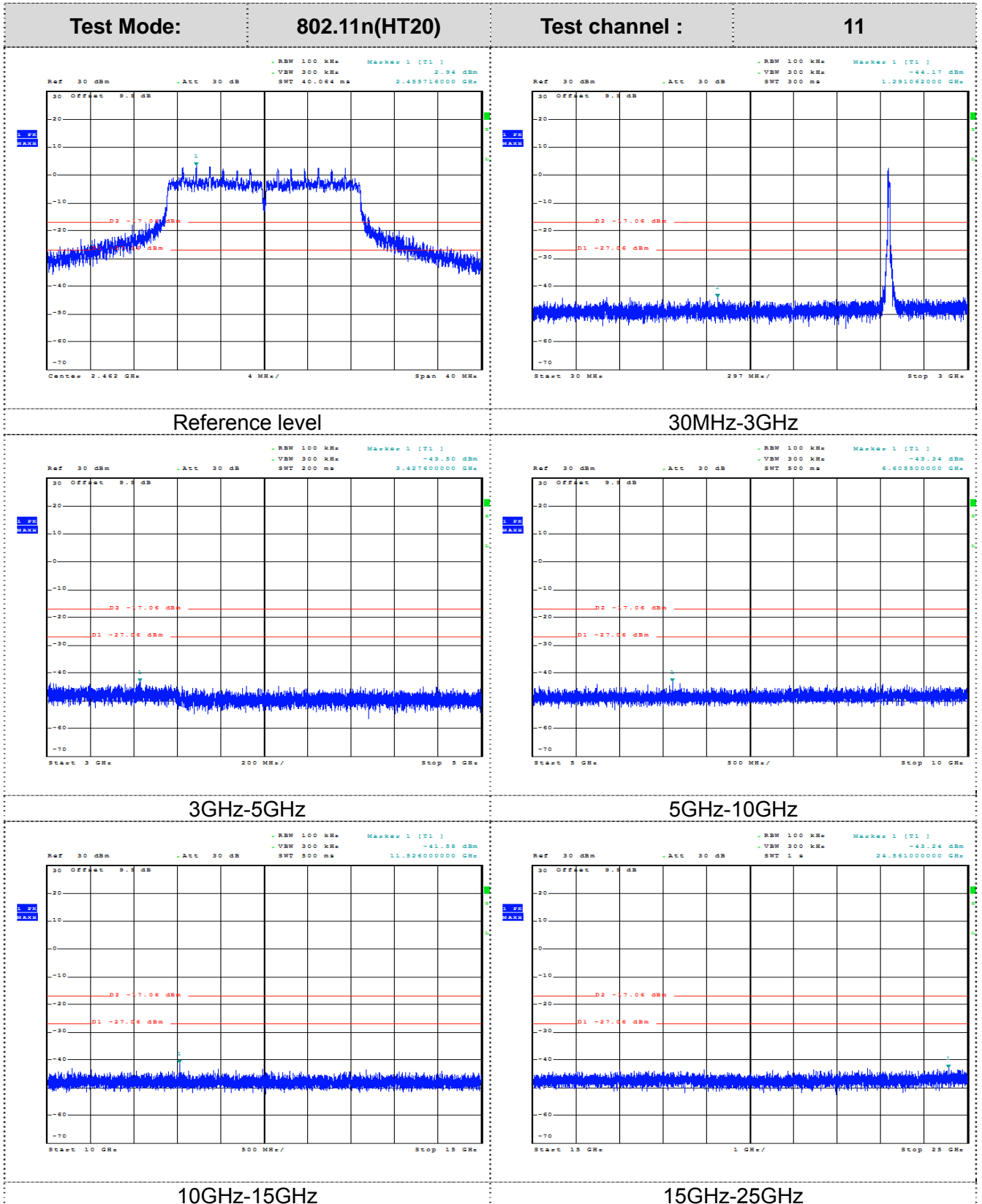

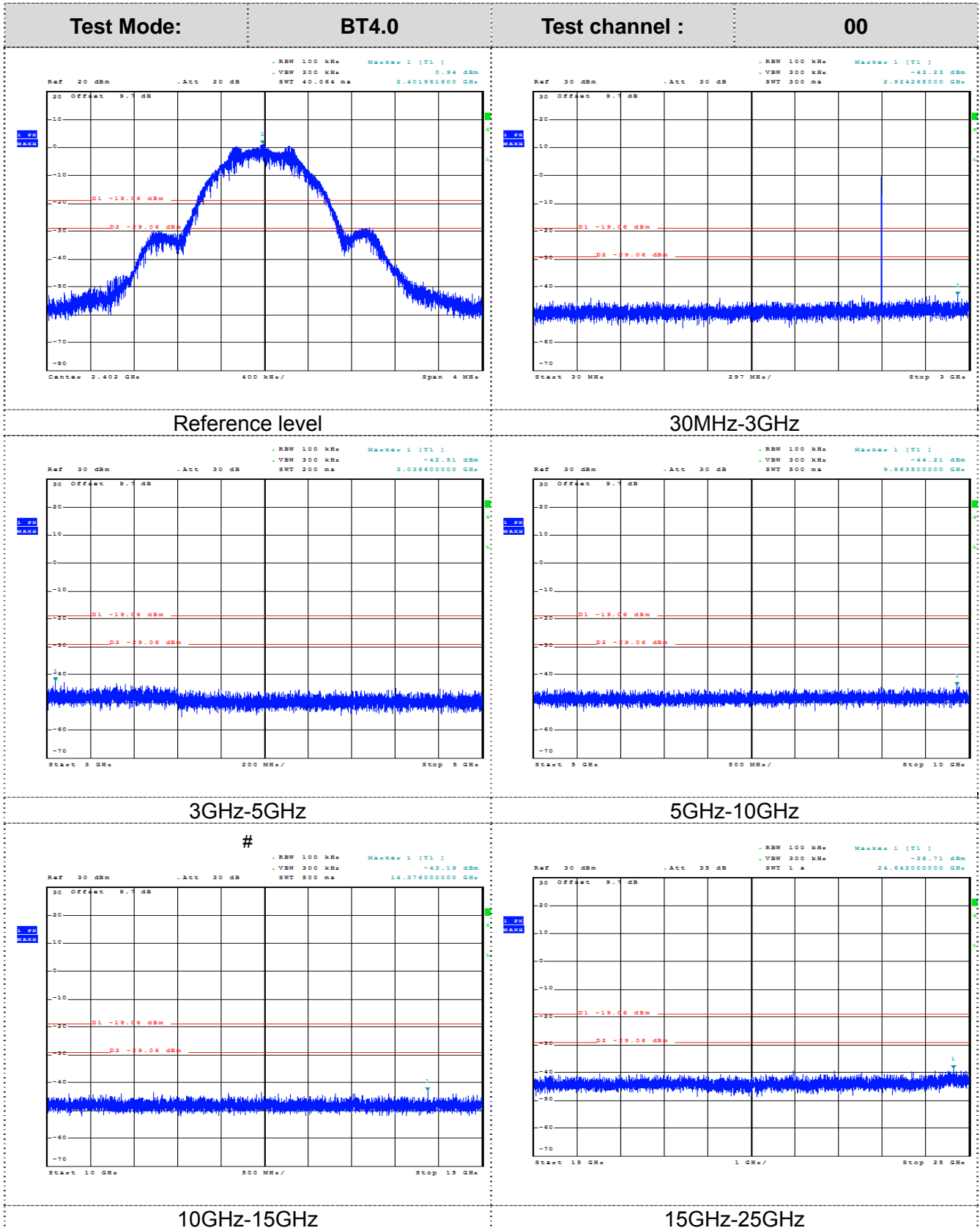

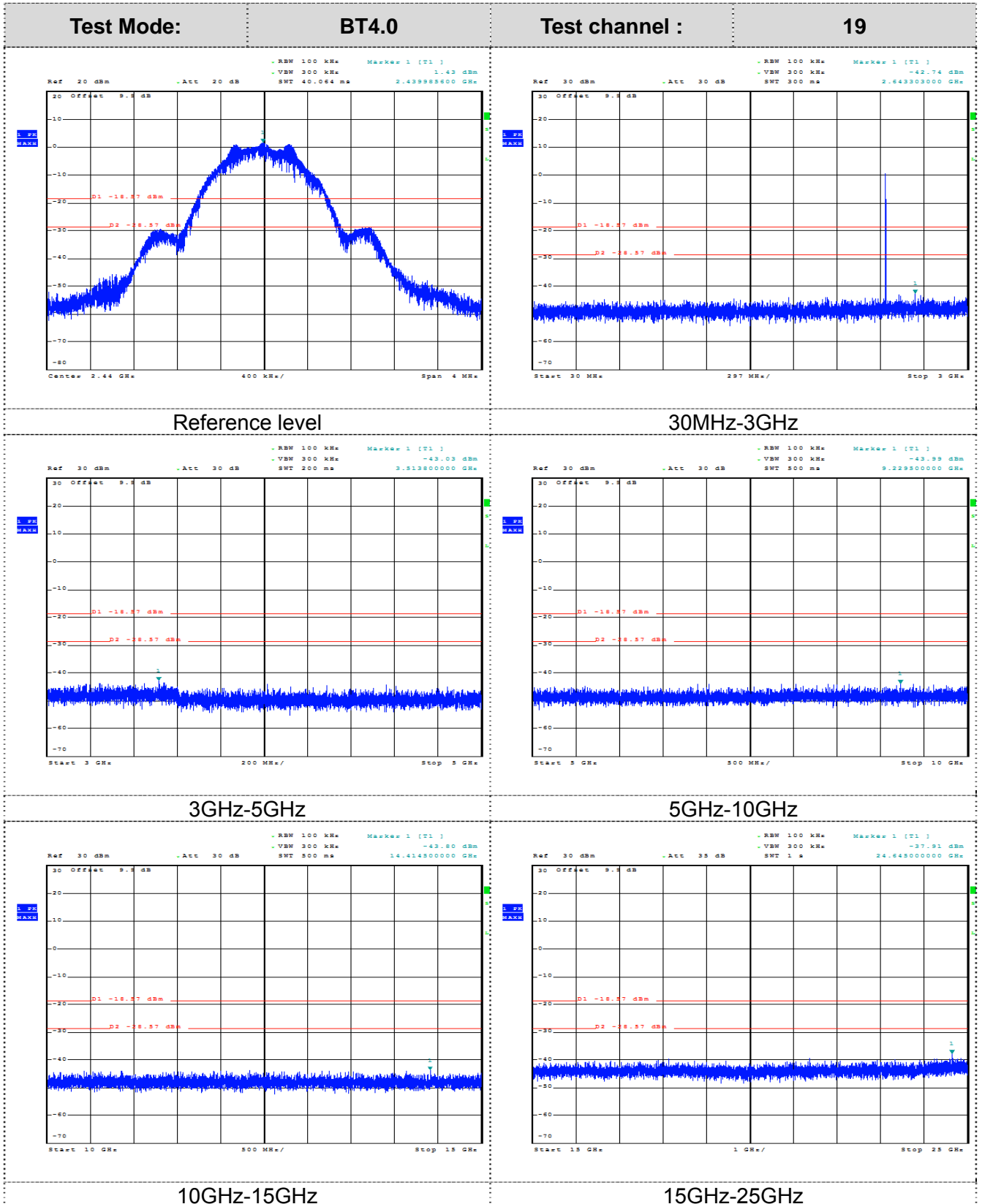

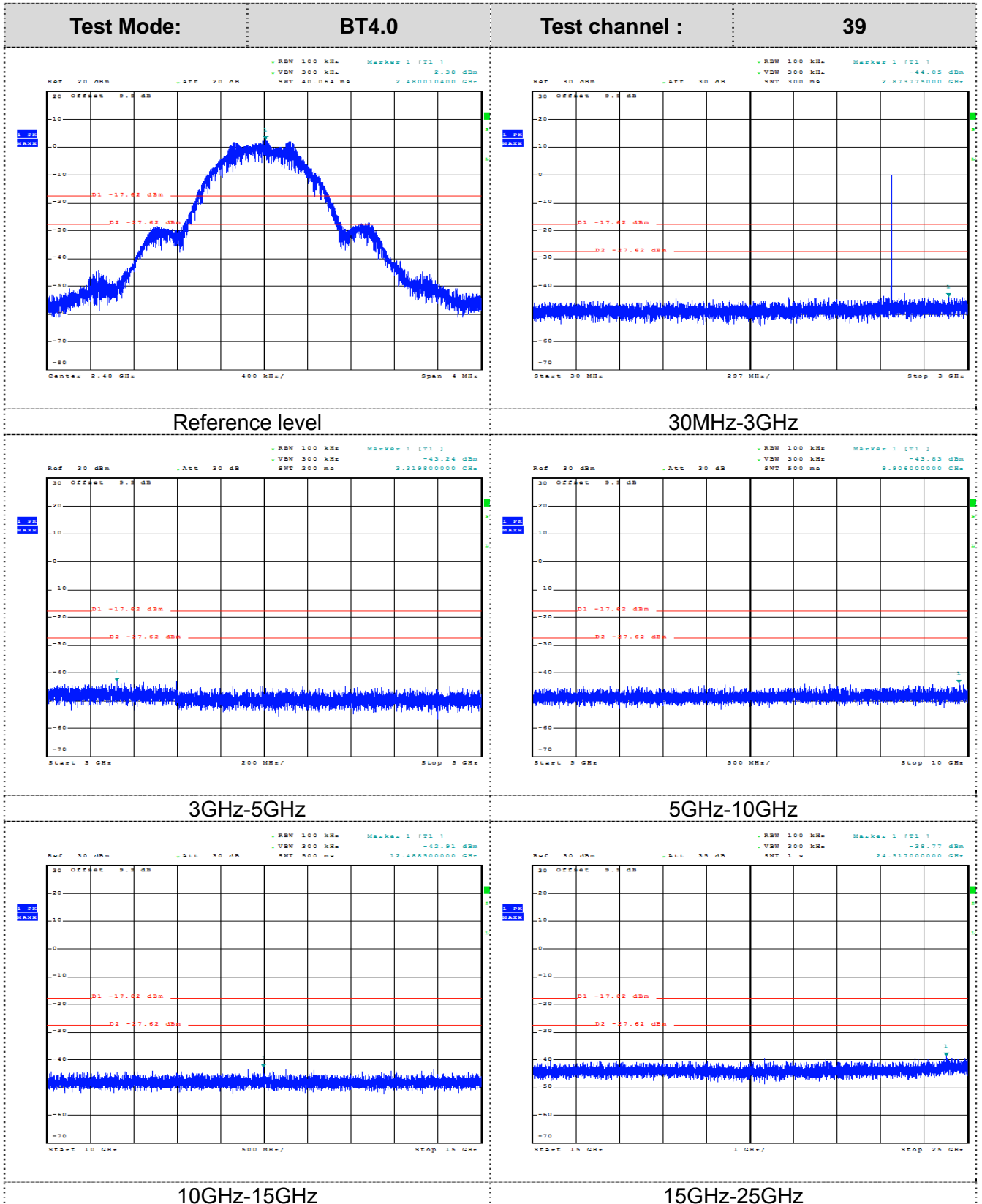

3.8. Antenna Requirement

Standard Applicable

For intentional device, according to FCC 47 CFR Section 15.203:

An intentional radiator shall be designed to ensure that no antenna other than that furnished by the responsible party shall be used with the device. The use of a permanently attached antenna or of an antenna that uses a unique coupling to the intentional radiator, the manufacturer may design the unit so that a broken antenna can be replaced by the user, but the use of a standard antenna jack or electrical connector is prohibited

FCC CFR Title 47 Part 15 Subpart C Section 15.247(c) (1) (I):

(i) Systems operating in the 2400-2483.5 MHz band that is used exclusively for fixed. Point-to-point operations may employ transmitting antennas with directional gain greater than 6dBi provided the maximum conducted output power of the intentional radiator is reduced by 1 dB for every 3 dB that the directional gain of the antenna exceeds 6dBi.

Test Result:

The maximum gain of Bluetooth antenna was 1.2 dBi.

Antenna type: FPCB antenna

Antenna connector: pogo pin connector

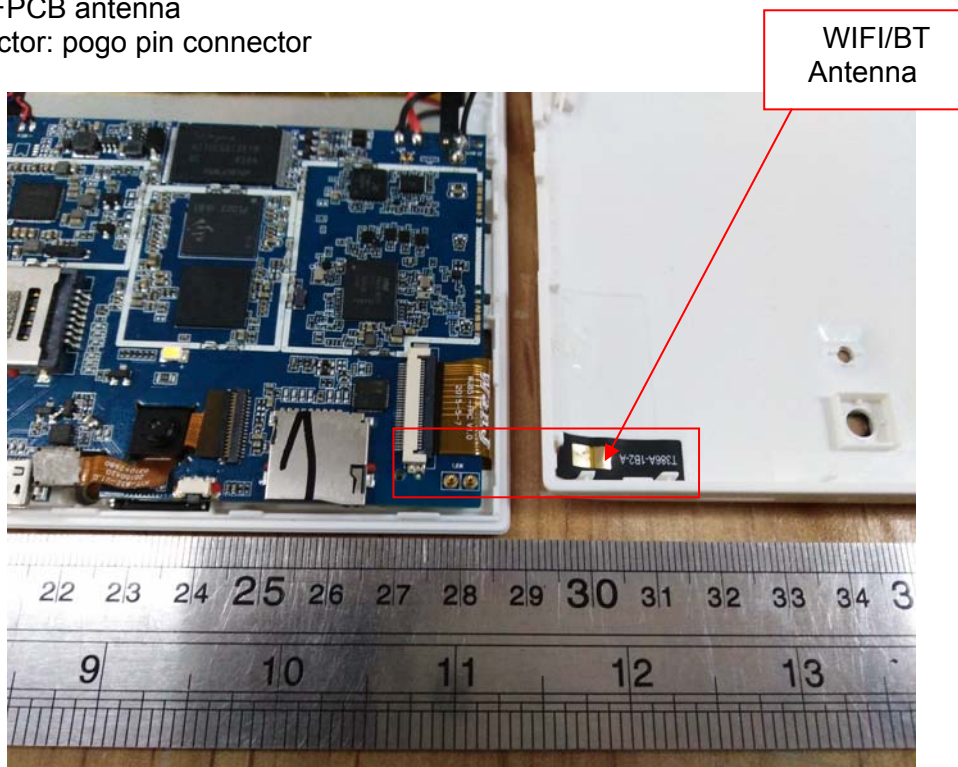

4. EUT TEST PHOTO

Radiated Emission (30MHz-1GHz)



Radiated Emission (1GHz-25GHz)



Conducted Emission





5. PHOTOGRAPHS OF EUT CONSTRUCTIONAL

Please reference to the test report No.: GTI20160197F-1

*****THE END*****