



Shenzhen GTI Technology Co., Ltd.

1F,2 Block, Jiaquan Building, Guanlan High-tech Park Baoan District,
Shenzhen, Guangdong, China.

Tel: +86-755-27559792

Fax: +86-755-86116468

Report No.: GTI20160197F-3

Page 1 of 44

TEST REPORT

Product Name: Tablet PC

Trademark: /

Model/Type reference: A723G

Listed Model(s): See the page 6

FCC ID.....: 2AEB5-A723

Test Standards: **FCC Part 22: PUBLIC MOBILE SERVICES**
FCC Part 24: PERSONAL COMMUNICATIONS SERVICES

Applicant: AOC

Address of Applicant.....: 14F-5, NO.258, Liancheng Rd., Zhonghe Dist., New Taipei
City, Taiwan

Date of Receipt: Mar. 05, 2016

Date of Test Date.....: Mar. 05, 2016- Mar. 11, 2016

Data of Issue.: Mar. 11, 2016

Test result	Pass *
--------------------	---------------

* In the configuration tested, the EUT complied with the standards specified above

GENERAL DESCRIPTION OF EUT	
Equipment:	Tablet PC
Model Name:	A723G
Manufacturer:	Shenzhen KTC Technology Co., Ltd.
Manufacturer Address:	Northern Wuhe Road, Gangtou, Buji, Longgang, Shenzhen, China
Power Rating:	DC 3.7V from 2700mAh by rechargeable battery DC 5.0V from Adapter

Compiled By:

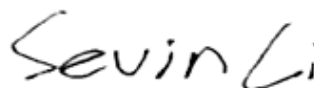

(Sevin Li)

Reviewed By:

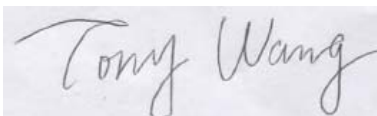

(Tony Wang)

Approved By:

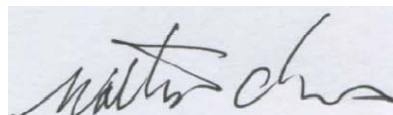

(Walter Chen)

This test report consists of 44 pages in total. It may be duplicated completely for legal use with the approval of the applicant. It should not be reproduced except in full, without the written approval of our laboratory. The client should not use it to claim product endorsement by GTI. The test results in the report only apply to the tested sample. The test report shall be invalid without all the signatures of compiler, reviewer and approver. Any objections must be raised to GTI within 15 days since the date when the report is received. It will not be taken into consideration beyond this limit.



Table of Contents

Page

1. SUMMARY.....	4
1.1. TEST STANDARDS.....	4
1.2. TEST DESCRIPTION.....	4
1.3. TEST FACILITY.....	5
1.4. MEASUREMENT UNCERTAINTY.....	5
2. GENERAL INFORMATION.....	6
2.1. ENVIRONMENTAL CONDITIONS.....	6
2.2. GENERAL DESCRIPTION OF EUT.....	6
2.3. DESCRIPTION OF TEST MODES AND TEST FREQUENCY.....	8
2.4. MEASUREMENT INSTRUMENTS LIST.....	9
3. TEST ITEM AND RESULTS.....	11
3.1. CONDUCTED OUTPUT POWER.....	11
3.2. OCCUPY BANDWIDTH.....	13
3.3. OUT OF BAND EMISSION AT ANTENNA TERMINALS.....	17
3.4. BAND EDGE COMPLIANCE.....	25
3.5. RADIATED POWER MEASUREMENT.....	29
3.6. RADIATED SPURIOUS EMISSION.....	33
3.7. FREQUENCY STABILITY.....	40
4. EUT TEST PHOTOS.....	43
5. PHOTOGRAPHS OF EUT CONSTRUCTIONAL.....	44

1. SUMMARY

1.1. Test Standards

[FCC Part 22 \(04-1-16 Edition\)](#): PRIVATE LAND MOBILE RADIO SERVICES.

[FCC Part 24\(04-1-16 Edition\)](#): PUBLIC MOBILE SERVICES

[TIA/EIA 603 D June 2010](#): Land Mobile FM or PM Communications Equipment Measurement and Performance Standards.

[FCC Part 2](#): FREQUENCY ALLOCA-TIONS AND RADIO TREATY MAT-TERS; GENERAL RULES AND REG-ULATIONS

[KDB971168 D01: v02r02](#): Power Meas License Digital Systems

[ANSI C63.10:2013](#): Methods of Measurement of Radio-Noise Emissions from Low-Voltage Electrical and Electronic Equipment in the Range of 9 kHz to 40 GHz

1.2. Test Description

Test Item	Section in CFR 47	Result
RF Output Power	Part 2.1046 Part 22.913 (a)(2) Part 24.232 (c)	Pass
Peak-to-Average Ratio	Part 24.232 (d)	Pass
Modulation Characteristics	Part 2.1047	Pass
99% & -26 dB Occupied Bandwidth	Part 2.1049 Part 22.917 Part 24.238	Pass
Spurious Emissions at Antenna Terminal	Part 2.1051 Part 22.917 (a) Part 24.238 (a)	Pass
Field Strength of Spurious Radiation	Part 2.1053 Part 22.917 (a) Part 24.238 (a)	Pass
Out of band emission, Band Edge	Part 22.917 (a) Part 24.238 (a)	Pass
Frequency stability	Part 2.1055 Part 22.355 Part 24.235	Pass

Note:

- The measurement uncertainty is not included in the test result.

1.3. Test Facility

1.3.1 Address of the test laboratory

Shenzhen General Testing & Inspection Technology Co., Ltd.

Add: 1F, 2 Block, Jiaquan Building, Guanlan High-tech Park Baoan District, Shenzhen, Guangdong, China

1.3.2 Laboratory accreditation

The test facility is recognized, certified, or accredited by the following organizations:

IC Registration No.: 9783A

The 3m alternate test site of Shenzhen GTI Technology Co., Ltd. EMC Laboratory has been registered by Certification and Engineer Bureau of Industry Canada for the performance of with Registration NO.: 9783A on Aug, 2011.

FCC-Registration No.:214666

Shenzhen GTI Technology Co., Ltd. EMC Laboratory has been registered and fully described in a report filed with the (FCC) Federal Communications Commission. The acceptance letter from the FCC is maintained in our files. Registration 214666, Sep 19, 2011

1.4. Measurement Uncertainty

The data and results referenced in this document are true and accurate. The reader is cautioned that there may be errors within the calibration limits of the equipment and facilities. The measurement uncertainty was calculated for all measurements listed in this test report acc. to CISPR 16 - 4 Specification for radio disturbance and immunity measuring apparatus and methods – Part 4: Uncertainty in EMC Measurements and is documented in the Shenzhen General Testing & Inspection Technology Co., Ltd quality system acc. to DIN EN ISO/IEC 17025. Furthermore, component and process variability of devices similar to that tested may result in additional deviation. The manufacturer has the sole responsibility of continued compliance of the device.

Hereafter the best measurement capability for General Testing & Inspection laboratory is reported:

Test Items	Measurement Uncertainty	Notes
Frequency stability	25 Hz	(1)
Transmitter power conducted	0.57 dB	(1)
Transmitter power Radiated	2.20 dB	(1)
Conducted spurious emission 9KHz-12.75 GHz	1.60 dB	(1)
Conducted Emission 9KHz-30MHz	3.39 dB	(1)
Radiated Emission 30~1000MHz	4.24 dB	(1)
Radiated Emission 1~18GHz	5.16 dB	(1)
Radiated Emission 18-40GHz	5.54 dB	(1)
Occupied Bandwidth	-----	(1)
Emission Mask	-----	(1)
Modulation Characteristic	-----	(1)
Transmitter Frequency Behavior	-----	(1)

(1) This uncertainty represents an expanded uncertainty expressed at approximately the 95% confidence level using a coverage factor of k=1.96.

2. GENERAL INFORMATION

2.1. Environmental conditions

During the measurement the environmental conditions were within the listed ranges:

Normal Temperature:	25°C
Relative Humidity:	55 %
Air Pressure:	101 kPa

2.2. General Description of EUT

Product Name:	Tablet PC
Model/Type reference:	A723G
List Model:	700P***, &&700*****
Model difference:	700P*** (1st* could be 0-99 or A-Z, means different client code; 2nd* could be 0-99 or A-Z or blank, stands for the shape or color of enclosure, no impact on Products safety and EMC characteristics); &&700***** (& could be "A-Z" or "a-z", * could be "0-99", "A-Z", "a-z", "-", "/" or blank, means different client code, no impact on Products safety and EMC characteristics
Power supply:	DC 3.7V from battery, 2700mAh Battery model: 338085
Adapter1 information:	Model: EP29-05015WULZ Input: 100-240, 50/60Hz, 0.35Max Output: 5V===1500mA
Adapter2 information:	Model: SA69-050150U Input: 100-240, 50/60Hz, 0.30Max Output: 5V===1500mA
Hardware version:	V10
Software version:	V5.1
2G	
Operation Band:	GSM850, PCS1900
Supported Type:	GSM/GPRS
Power Class:	GSM850:Power Class 4 PCS1900:Power Class 1
Modulation Type:	GMSK for GSM/GPRS
GSM Release Version	R99
GPRS Multislot Class	12
Antenna type:	FPCB Antenna
Antenna gain:	GSM850:1.1dB PCS1900:1.3dB
WCDMA	
Operation Band:	FDD Band II & Band V

Power Class:	Power Class 3
Modulation Type:	QPSK for WCDMA/HSUPA/HSDPA
WCDMA Release Version:	R99
HSDPA Release Version:	Release 7, CAT14
HSUPA Release Version:	Release 6, CAT6
DC-HSUPA Release Version:	Not Supported
Antenna type:	FPCB Antenna
Antenna gain:	Band II:1.4dB Band V:1.1dB
Hotspot Function:	Support
Voice Function:	Support

Note: For a more detailed features description, please refer to the manufacturer's specifications or the User's Manual.

2.3. Description of Test Modes and Test Frequency

The EUT has been tested under typical operating condition. The CUM200 used to control the EUT staying in continuous transmitting and receiving mode for testing.

This EUT owns SIM1 and SIM2, contains two SIM card slots, and the EUT supports Dual Standby but without Dual Active, they share the same software and hardware(RF module and Power supply, etc.). When a call is established on one SIM, the other is no longer active, callers to the other SIM will hear a message that the phone is switched off or they'll be redirected to voicemail. After pre-scan test, the SIM 1 which supported all band(WCDMA,GSM) was the worst case, so we tested and recorded the results according to SIM 1.

Test Frequency:

GSM 850		PCS1900	
Channel	Frequency (MHz)	Channel	Frequency (MHz)
128	824.20	512	1850.20
190	836.60	661	1880.00
251	848.80	810	1909.80

FDD Band II		FDD Band V	
Channel	Frequency (MHz)	Channel	Frequency (MHz)
9262	1852.4	4132	826.40
9400	1880.0	4182	836.60
9538	1907.6	4233	846.60

2.4. Measurement Instruments List

Output Power (Radiated) & Radiated Spurious Emission					
Item	Test Equipment	Manufacturer	Model No.	Serial No.	Calibrated until
1	EMI Test Receiver	R&S	ESCI	100967	Jan 04,2017
2	High pass filter	Compliance Direction systems	BSU-6	34202	Jan 04,2017
3	Log-Bicon Antenna	Schwarzbeck	CBL6141A	4180	Jan 04,2017
4	Log-Bicon Antenna	Schwarzbeck	CBL6141A	4181	Jan 04,2017
5	Spectrum Analyzer	Rohde & Schwarz	FSU	100105	Jan 04,2017
6	Horn Antenna	Schwarzbeck	BBHA 9120D	648	Jan 07,2017
7	Horn Antenna	Schwarzbeck	BBHA 9120D	649	Jan 07,2017
8	Ultra-Broadband Antenna	ShwarzBeck	BBHA9170	25841	Jan 07,2017
9	Ultra-Broadband Antenna	ShwarzBeck	BBHA9170	25842	Jan 07,2017
10	Pre-Amplifier	HP	8447D	1937A03050	Jan 04,2017
11	Pre-Amplifier	EMCI	EMC051835	980075	Jan 04,2017
14	UNIVERSAL RADIO COMMUNICATION	Rohde & Schwarz	CMU200	114694	Jun.06,2016
15	Antenna Mast	UC	UC3000	N/A	N/A
16	Antenna mast	MATURO	TAM-4.0-P	N/A	N/A
17	Turn Table	UC	UC3000	N/A	N/A
18	Cable Below 1GHz	Schwarzbeck	AK9515E	33155	Jan 04,2017
19	Cable Above 1GHz	Hubersuhner	SUCOFLEX102	DA1580	Jan 04,2017

Output Power(Conducted) & Occupied Bandwidth & Emission Bandwidth & Band Edge Compliance & Conducted Spurious Emission

Item	Test Equipment	Manufacturer	Model No.	Serial No.	Calibrated until
1	Power Meter	Anritsu	ML2487B	110553	July 10,2016
2	Power Sensor	Anritsu	MA2411B	100345	July 10,2016
3	UNIVERSAL RADIO COMMUNICATION	Rohde & Schwarz	CMU200	114694	Jun.06,2016
4	Spectrum Analyzer	Rohde & Schwarz	FSU	100105	Jan 04,2017
5	RF Cable	Schwarzbeck	AH32D4	SF0150	Jan 04,2017
6	Climate Chamber	ESPEC	EL-10KA	05107008	Oct 25,2016
7	Temporary Antenna connector	Schwarzbeck	SMA24D	ED1201	Jan 04,2017

Note: The temporary antenna connector is soldered on the PCB board in order to perform conducted tests and this temporary antenna connector is listed in the equipment list.

Frequency Stability

Item	Test Equipment	Manufacturer	Model No.	Serial No.	Calibrated until
1	UNIVERSAL RADIO COMMUNICATION	Rohde & Schwarz	CMU200	114694	Jun.06,2016
2	Spectrum Analyzer	Rohde & Schwarz	FSU	100105	Jan 04,2017
3	Splitter	Mini-Circuit	ZAPD-4	400059	Jan. 07, 2017
4	Climate Chamber	ESPEC	EL-10KA	05107008	Oct 25,2016
5	Temporary Antenna connector	Schwarzbeck	SMA24D	ED1201	Jan 04,2017

Note: The temporary antenna connector is soldered on the PCB board in order to perform conducted tests and this temporary antenna connector is listed in the equipment list.

Note: 1. The Cal. Interval was one year.

2. The cable loss has calculated in test result which connection between each test instruments.

3. TEST ITEM AND RESULTS

3.1. Conducted Output Power

LIMIT:

GSM850/WCDMA Band V: 7W

PCS1900/WCDMA Band II: 2W

The Peak-to-Average Ratio (PAR) of the transmission may not exceed 13 dB.

TEST CONFIGURATION

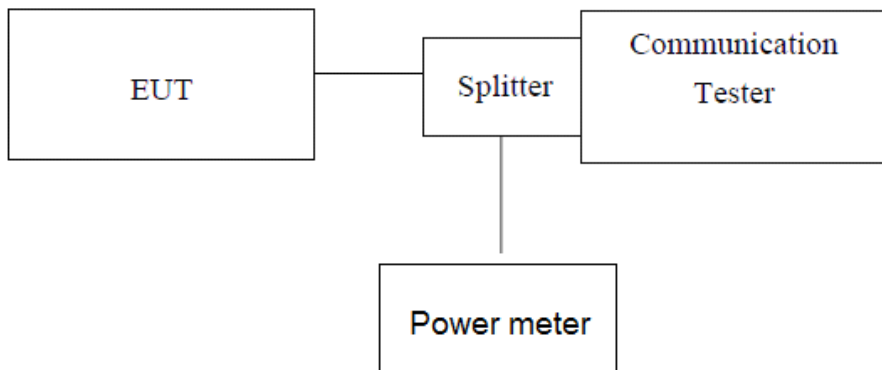

Note: Measurement setup for testing on Antenna connector

TEST PROCEDURE

1. The transmitter output port was connected to base station.
2. The RF output of EUT was connected to the power meter by RF cable and attenuator, the path loss was compensated to the results for each measurement.
3. Set EUT at maximum power through base station.
4. Select lowest, middle, and highest channels for each band and different modulation.
5. Measure the maximum PK burst power and maximum Avg. burst power.

TEST RESULTS

Note: 1.Peak-to-Average Ratio= maximum PK burst power-maximum Avg. burst power.

GSM Conducted Power

Band		Burst Average Power (dBm)			Peak-to-Average Ratio (dB)		
GSM850	TX Channel	128	190	251	128	190	251
	Frequency(MHz)	824.2	836.6	848.8	824.2	836.6	848.8
	GSM	31.22	31.47	31.95	/	/	/
	GPRS (Slot 1)	30.98	30.85	31.21	/	/	/
	GPRS (Slot 2)	28.95	28.80	28.96	/	/	/
	GPRS (Slot 3)	27.52	27.42	27.65	/	/	/
	GPRS (Slot 4)	26.42	26.39	26.86	/	/	/

Band		Burst Average Power (dBm)			Peak-to-Average Ratio (dB)		
GSM1900	TX Channel	512	661	810	512	661	810
	Frequency(MHz)	1850.2	1880	1909.8	1850.2	1880	1909.8
	GSM	28.22	28.27	28.62	9.32	9.36	9.56
	GPRS (Slot 1)	28.02	28.01	28.41	9.76	9.52	9.73
	GPRS (Slot 2)	27.12	27.02	27.35	9.86	9.67	9.84
	GPRS (Slot 3)	26.26	26.14	26.45	9.89	9.75	9.92
	GPRS (Slot 4)	25.57	25.62	25.71	9.92	9.84	9.97

WCDMA conducted output power

WCDMA Band V	Item	band	Burst Average Power (dBm)			Peak-to-Average Ratio (dB)		
		ARFCN	4132	4183	4233	4132	4183	4233
		subtest	dBm					
RMC 12.2kbps	non		21.25	21.33	21.94	/	/	/
	HSDPA	1	21.03	21.12	21.76	/	/	/
		2	21.08	21.22	21.71	/	/	/
		3	20.73	20.91	21.52	/	/	/
4		20.75	20.83	21.44	/	/	/	
HSUPA	1	21.00	21.02	21.72	/	/	/	
	2	20.99	20.95	21.71	/	/	/	
	3	20.71	20.65	21.43	/	/	/	
	4	20.58	20.78	21.24	/	/	/	
	5	20.89	21.03	21.71	/	/	/	

WCDMA Band II	Item	band	Burst Average Power (dBm)			Peak-to-Average Ratio (dB)		
		ARFCN	9262	9400	9538	9262	9400	9538
		subtest	dBm					
RMC 12.2kbps	non		20.11	20.04	20.18	3.76	3.82	3.81
	HSDPA	1	19.87	19.92	19.94	3.66	3.76	3.80
		2	19.93	19.79	20.06	3.60	3.64	3.79
		3	19.62	19.44	19.68	3.67	3.67	3.68
4		19.59	19.54	19.73	3.69	3.69	3.81	
HSUPA	1	19.81	19.75	19.96	3.68	3.68	3.86	
	2	19.71	19.71	19.80	3.78	3.63	3.95	
	3	19.55	19.47	19.55	3.65	3.54	3.86	
	4	19.45	19.51	19.58	3.53	3.58	3.84	
	5	19.83	19.77	19.86	3.43	3.73	3.75	

3.2. Occupy Bandwidth

TEST CONFIGURATION

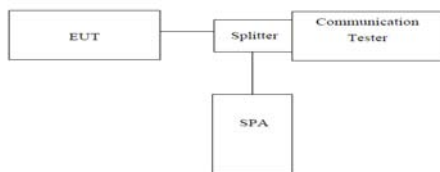

Note: Measurement setup for testing on Antenna connector

TEST PROCEDURE

1. The EUT's output RF connector was connected with a short cable to the spectrum analyzer
2. RBW was set to about 1% of emission BW, VBW ≥ 3 times RBW.
3. -26dBc display line was placed on the screen (or 99% bandwidth), the occupied bandwidth is the delta frequency between the two points where the display line intersects the signal trace.

TEST RESULTS

EUT Mode	Channel	Frequency (MHz)	99% Occupy bandwidth (KHz)	-26dB bandwidth (KHz)
GSM 850 (GMSK)	128	824.20	246.79	298.08
	190	836.60	250.00	318.91
	251	848.80	245.19	306.09
GPRS850 (GMSK, 1Slot)	128	824.20	245.19	309.29
	190	836.60	245.19	312.50
	251	848.80	246.79	310.90
PCS1900 (GMSK)	512	1850.20	248.40	310.90
	661	1880.00	246.79	314.10
	810	1909.80	246.79	283.65
GPRS1900 (GMSK, 1Slot)	512	1850.20	245.19	312.50
	661	1880.00	245.19	309.29
	810	1909.80	245.19	315.71
WCDMA Band II (QPSK RMC)	9262	1852.4	4070.5	4599
	9400	1880.0	4070.5	4631
	9538	1907.6	4070.5	4631
WCDMA Band V (QPSK RMC)	4132	826.4	4070.5	4631
	4183	836.6	4086.5	4583
	4233	846.6	4070.5	4599

Test plots as follow:

GMSK Modulation

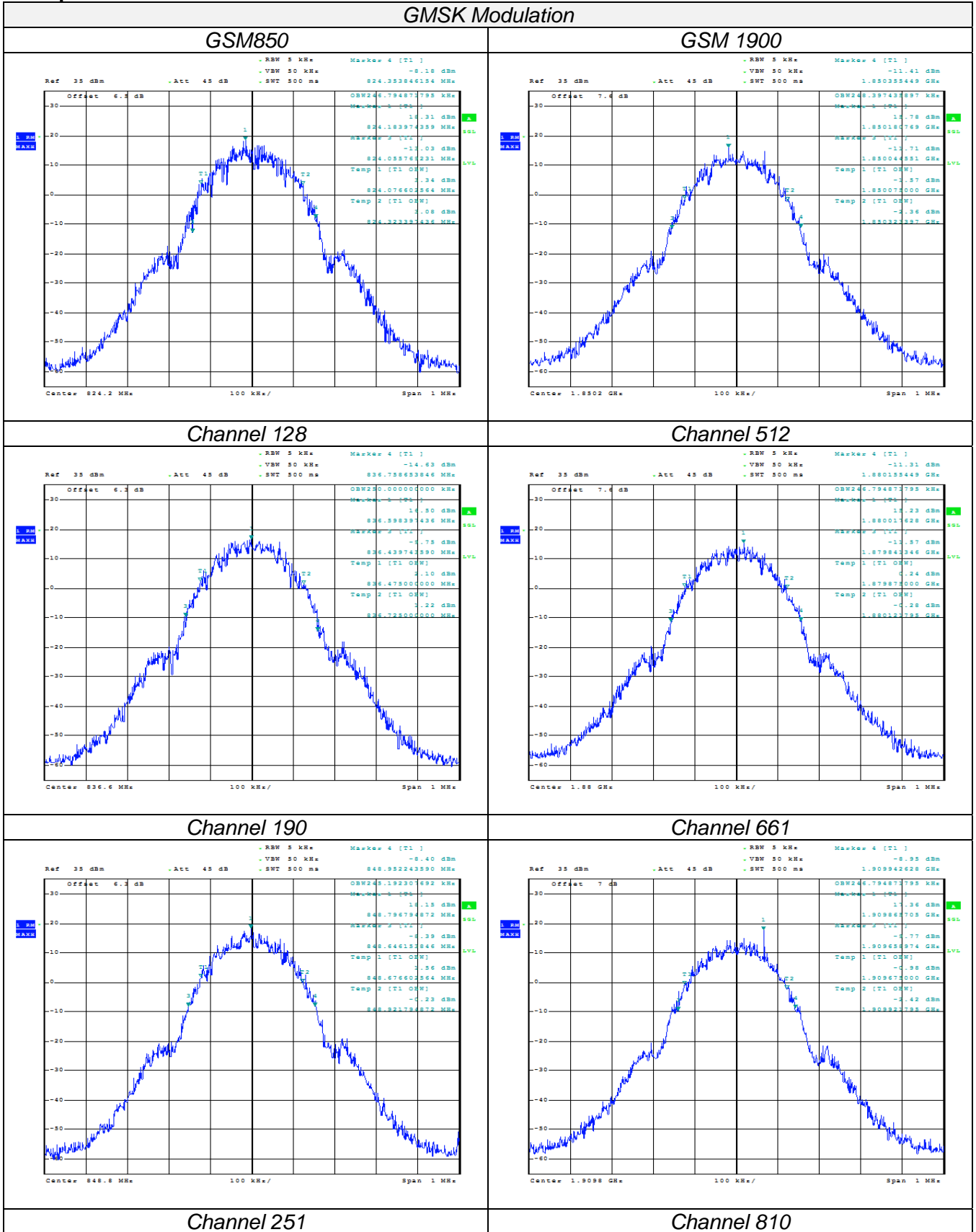

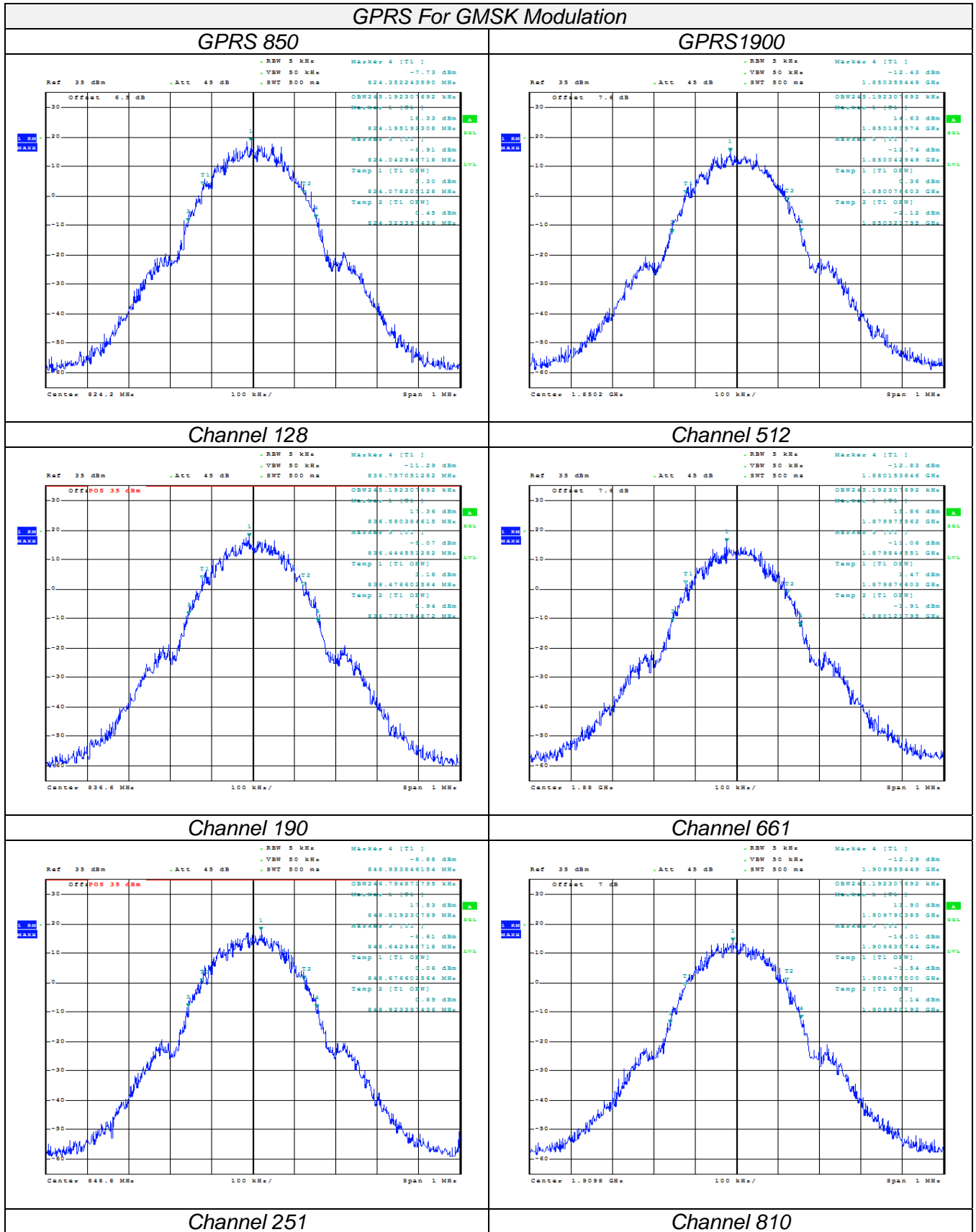

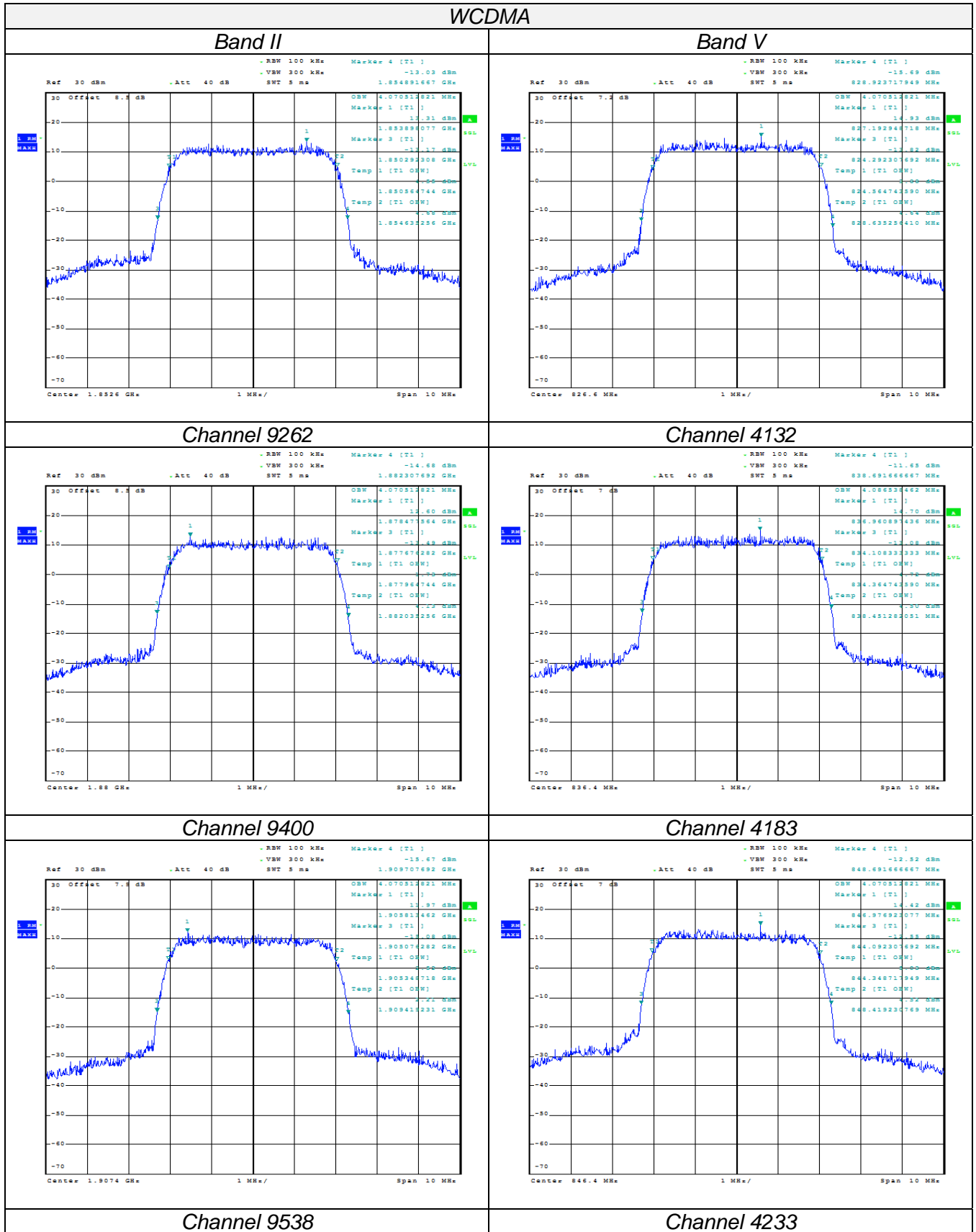

3.3. Out of band emission at antenna terminals

LIMIT

Part 24.238 and Part 22.917 specify that the power of any emission outside of the authorized operating frequency ranges must be attenuated below the transmitting power (P) by a factor of at least $43 + 10 \log(P)$ dB.

The specification that emissions shall be attenuated below the transmitter power (P) by at least $43 + 10 \log(P)$ dB, translates in the relevant power range (1 to 0.001 W) to -13 dBm. At 1 W the specified minimum attenuation becomes 43 dB and relative to a 30 dBm (1 W) carrier becomes a limit of -13 dBm. At 0.001 W (0 dBm) the minimum attenuation is 13 dB, which again yields a limit of -13 dBm. In this way a translation of the specification from relative to absolute terms is carried out.

TEST CONFIGURATION

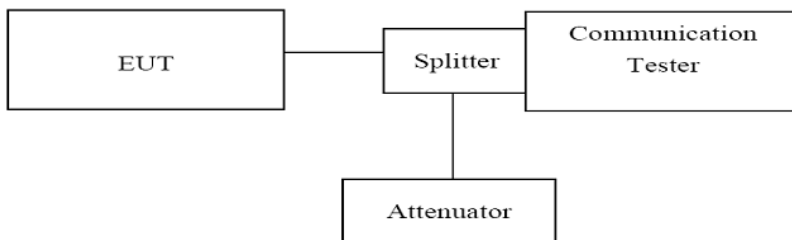

TEST PROCEDURE

1. The RF output of the transceiver was connected to a spectrum analyzer through appropriate attenuation.
2. The resolution bandwidth of the spectrum analyzer was set at 1MHz; sufficient scans were taken to show the out of band Emissions if any up to 10th harmonic.
3. For the out of band: Set the RBW = 1MHz VBW \geq 3 times RBW, Start=30MHz, Stop= 10th harmonic.

TEST RESULTS

Remark: we test all modulation type and record worst case as follows.

GSM850 Voice
GSM 1900 Voice
WCDMA Band II RMC
WCDMA Band V RMC

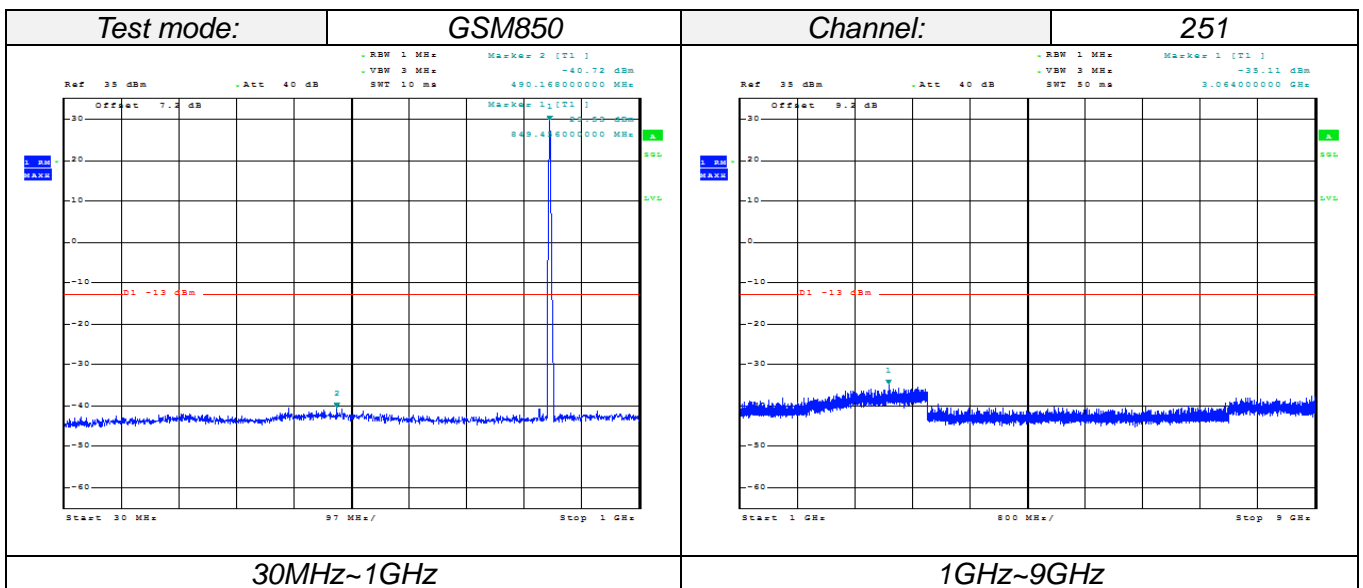
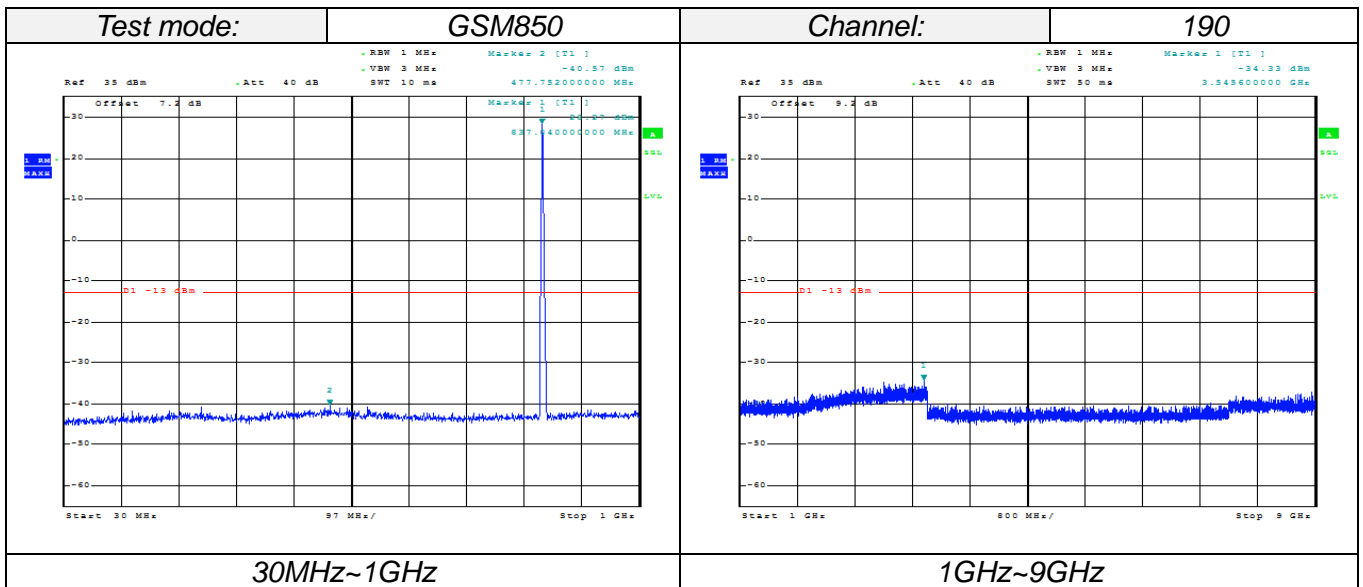
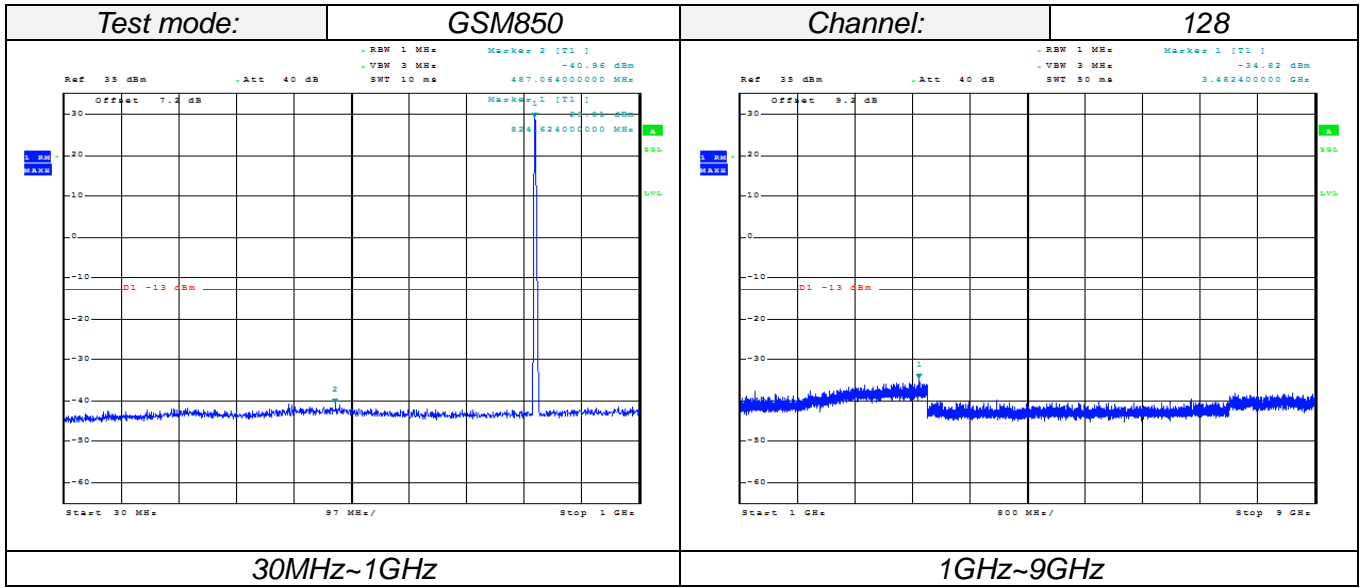

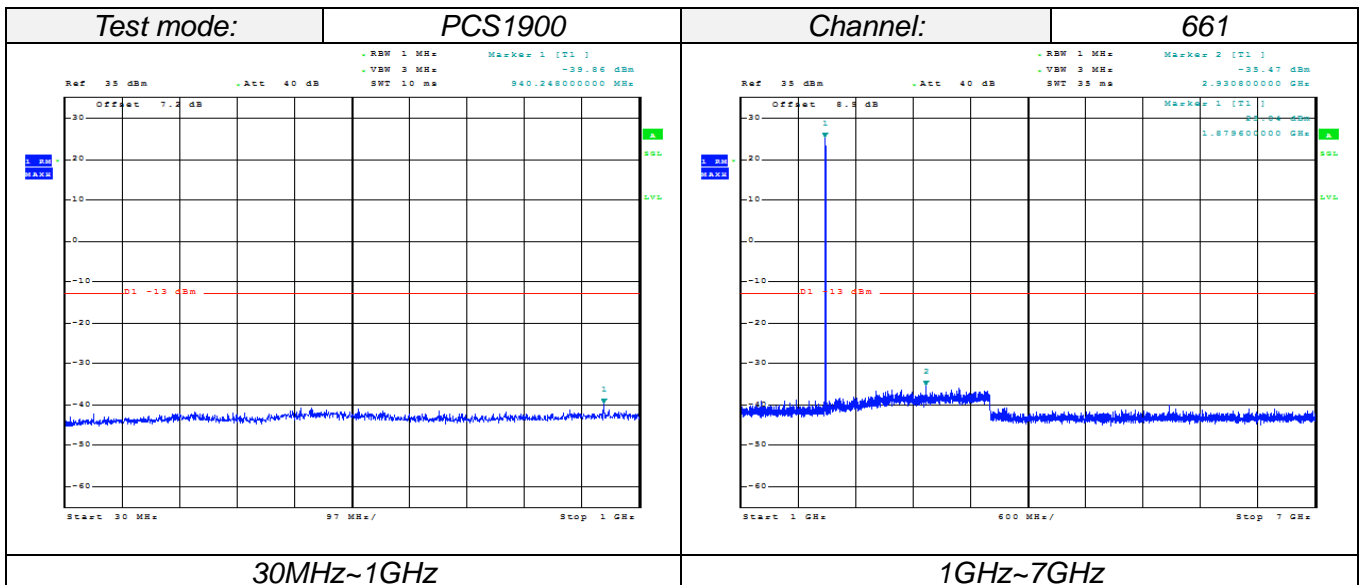
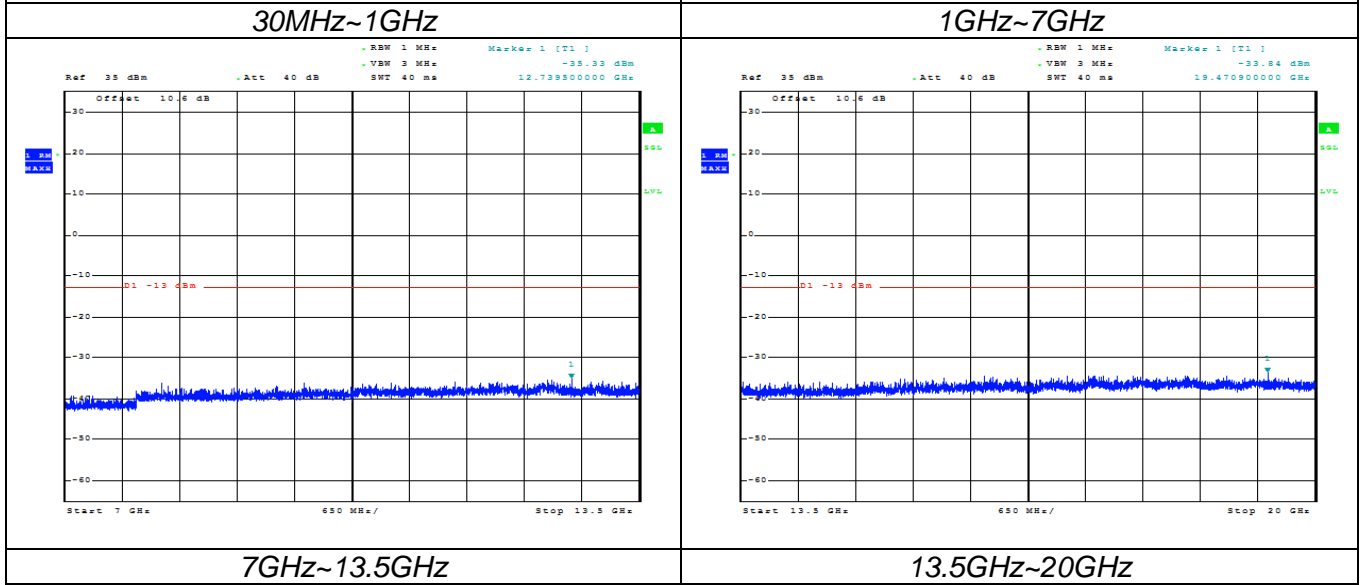
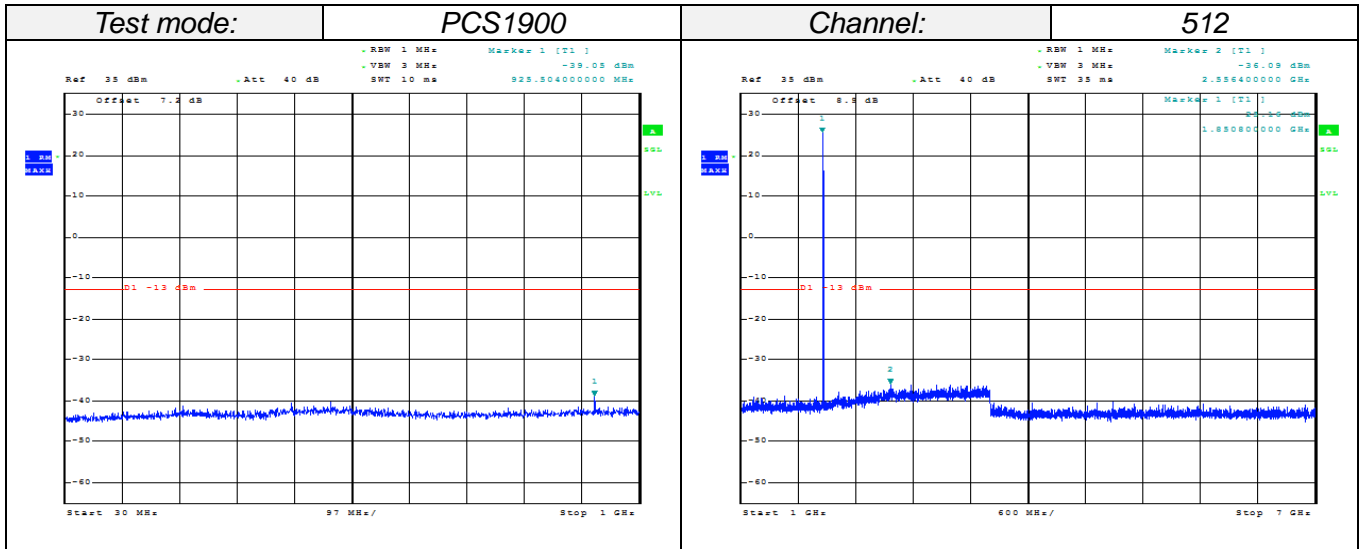

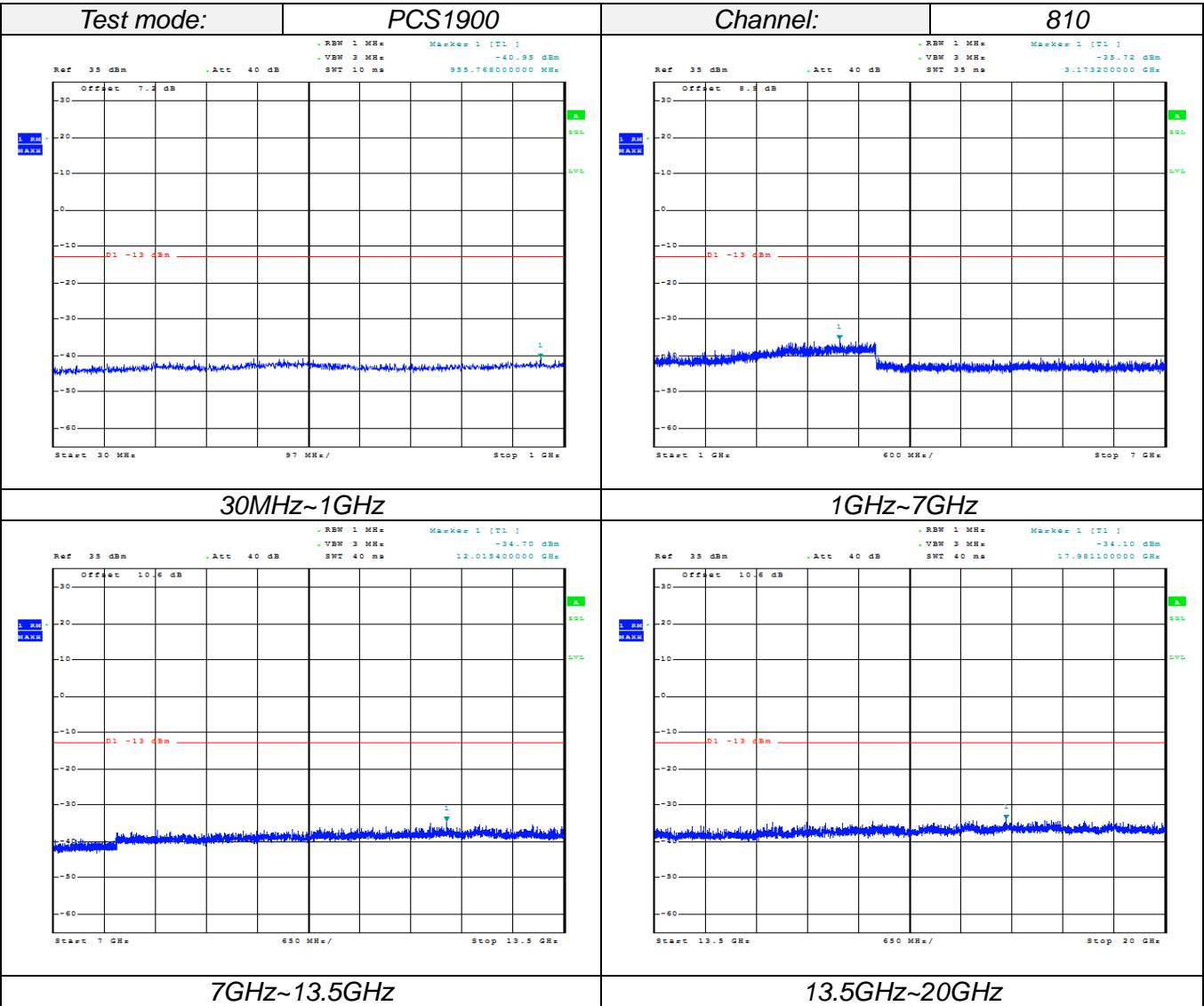
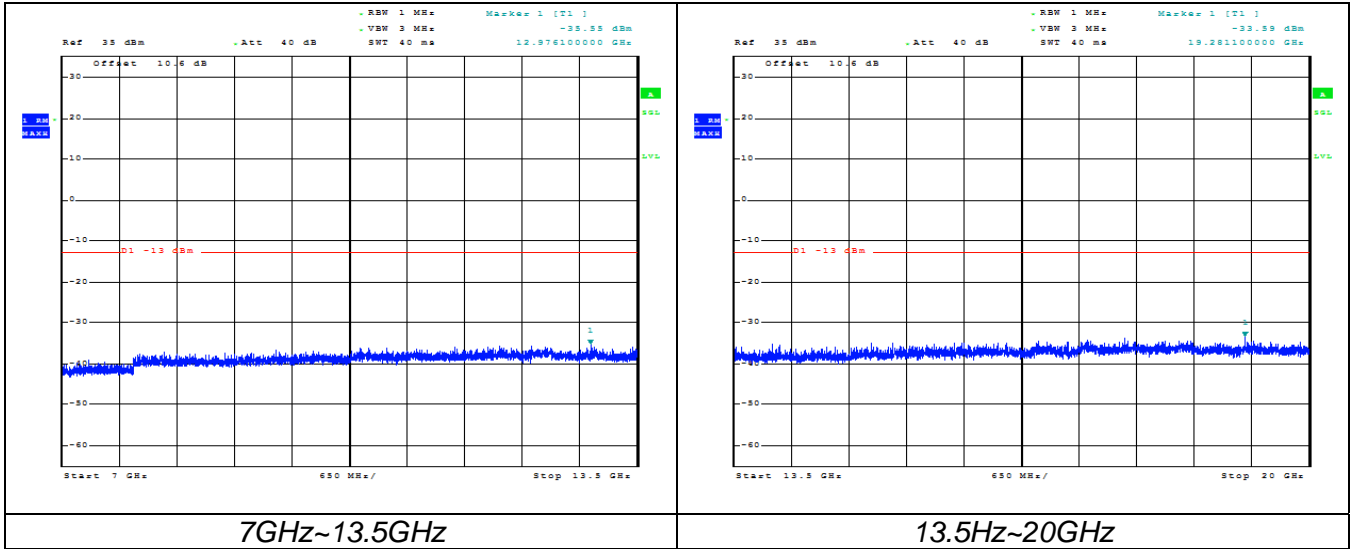

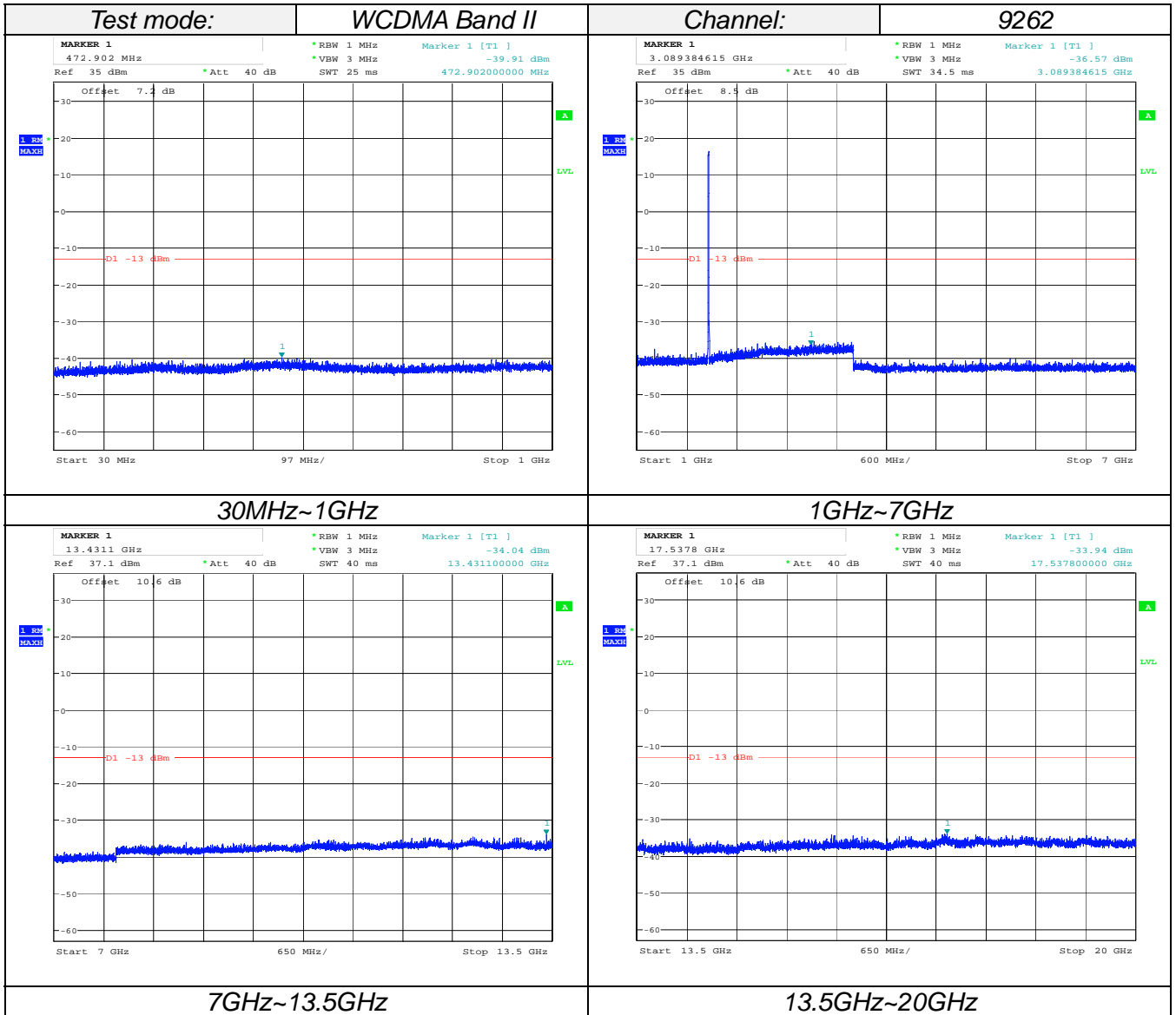

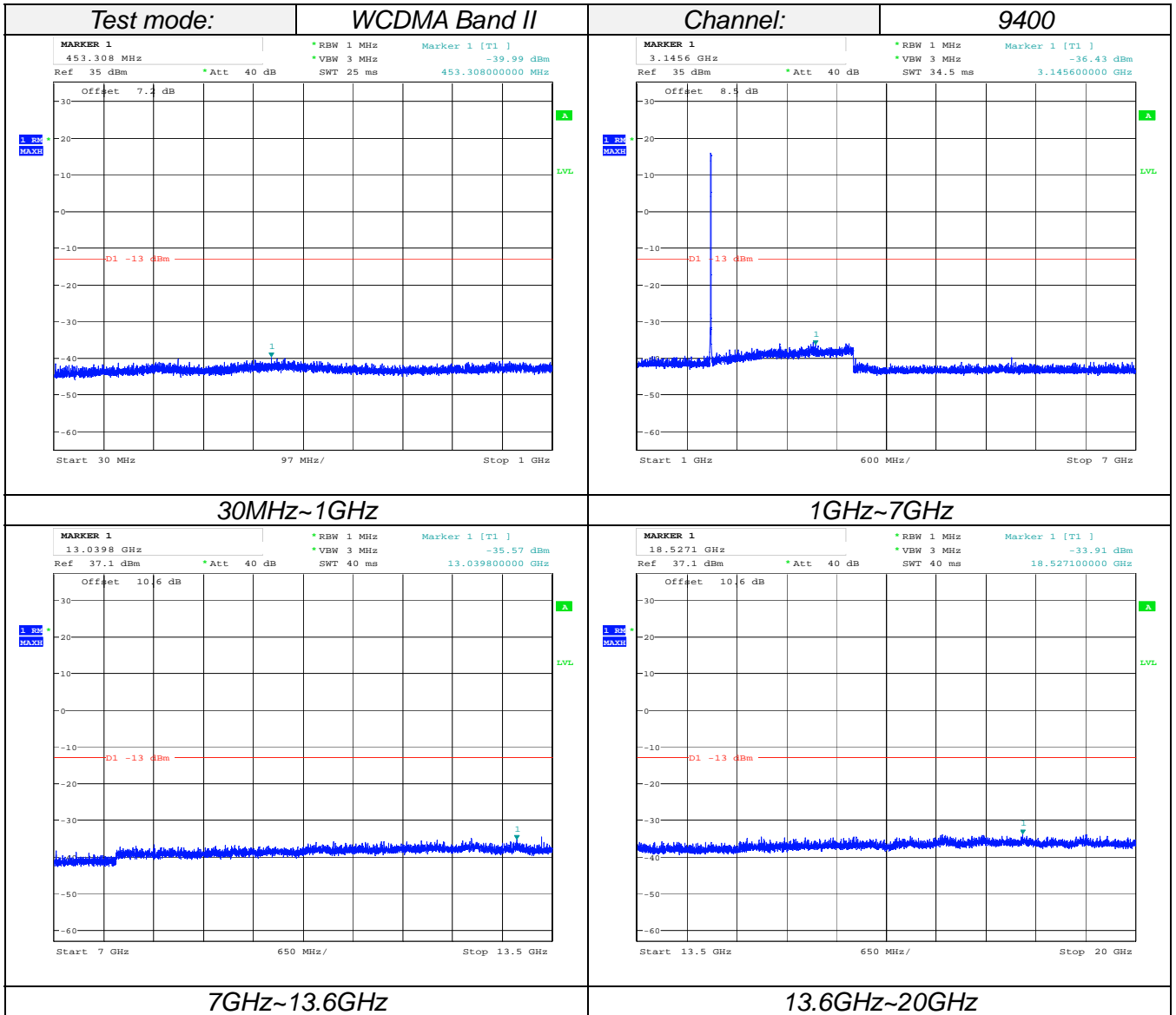

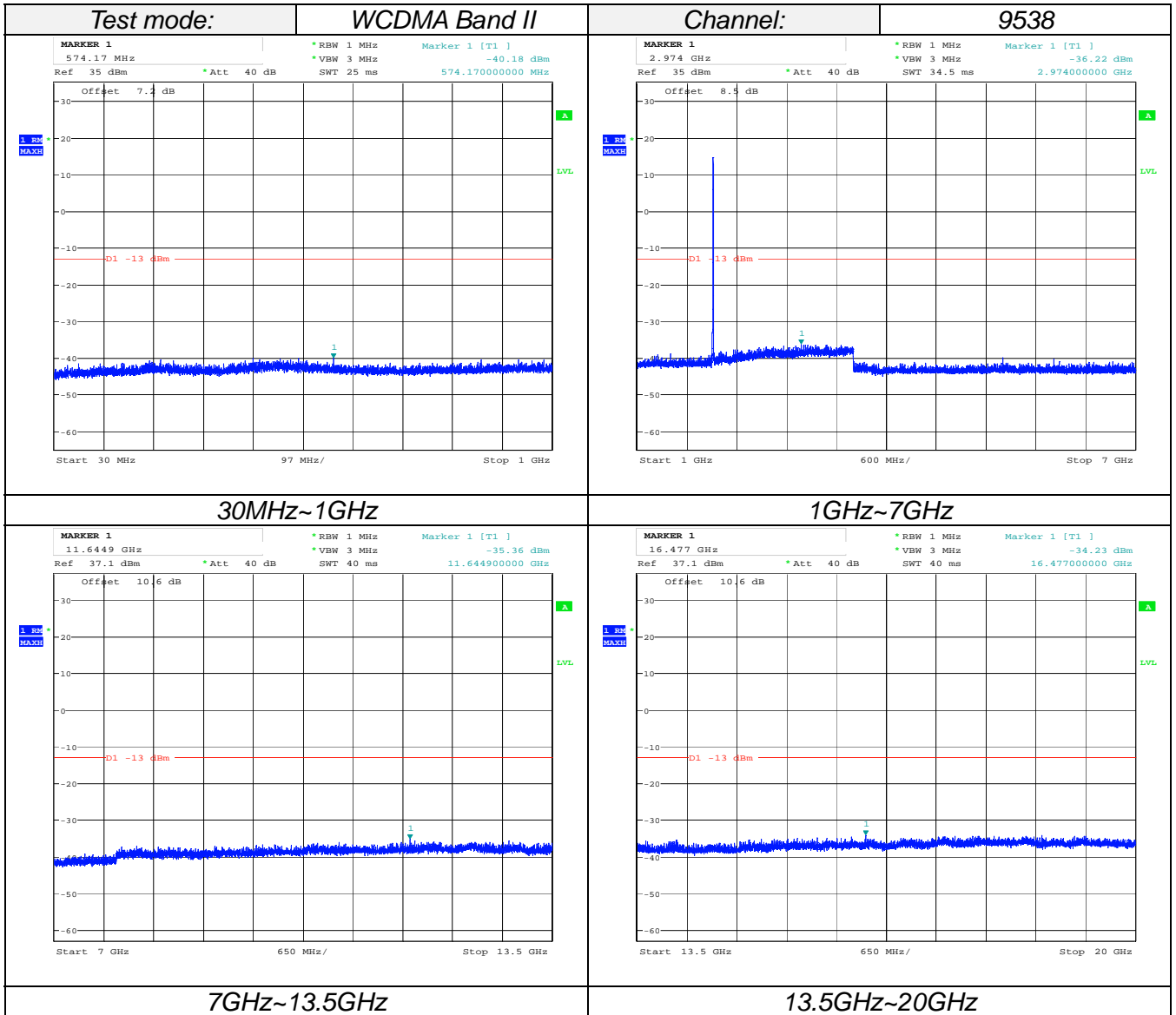

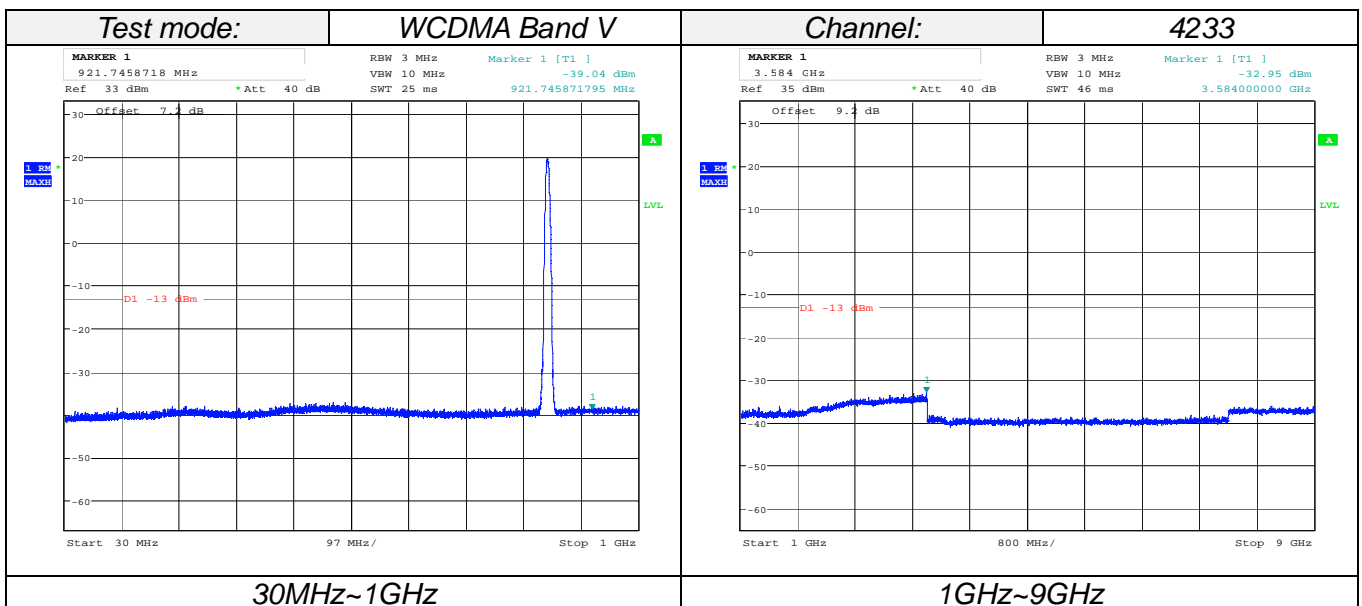
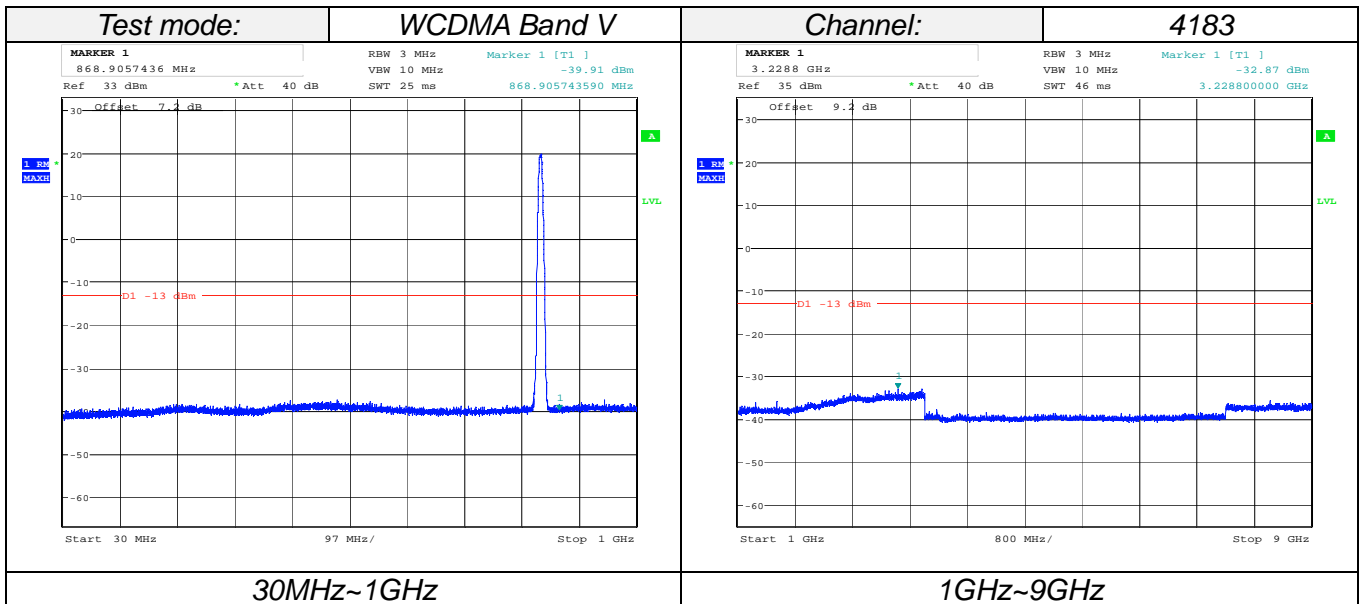
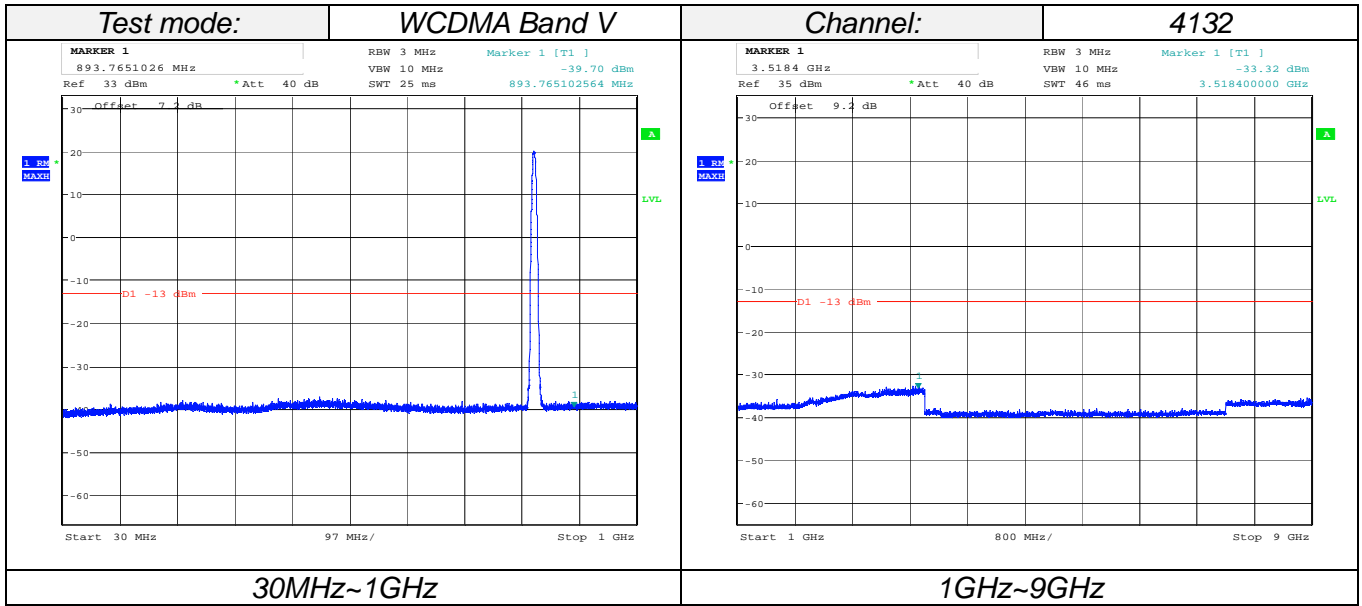

3.4. Band Edge compliance

LIMIT

Part 24.238 and Part 22.917 specify that the power of any emission outside of the authorized operating frequency ranges must be attenuated below the transmitting power (P) by a factor of at least $43 + 10 \log(P)$ dB.

The specification that emissions shall be attenuated below the transmitter power (P) by at least $43 + 10 \log(P)$ dB, translates in the relevant power range (1 to 0.001 W) to -13 dBm. At 1 W the specified minimum attenuation becomes 43 dB and relative to a 30 dBm (1 W) carrier becomes a limit of -13 dBm. At 0.001 W (0 dBm) the minimum attenuation is 13 dB, which again yields a limit of -13 dBm. In this way a translation of the specification from relative to absolute terms is carried out.

TEST CONFIGURATION

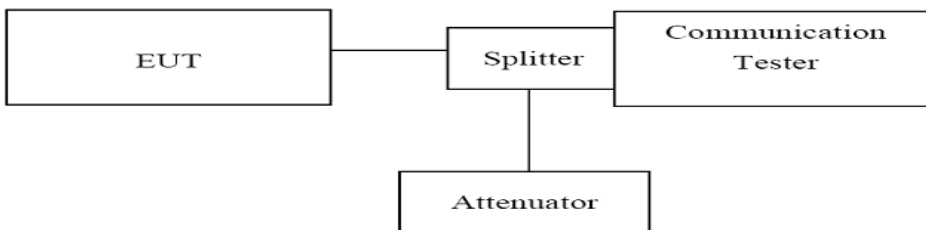

TEST PROCEDURE

1. The RF output of the transceiver was connected to a spectrum analyzer through appropriate attenuation.
2. Set the RBW=5 KHz, VBW = 50KHz, Span=1MHz Sweep time= Auto for 2G system measurement.
3. Set the RBW=50 KHz, VBW = 300KHz, Span=1MHz Sweep time= Auto for 3G system measurement.

TEST RESULTS

Remark: we test all modulation type and record worst case as follows.

GSM850 Voice and GPRS 850 1 slot
GSM 1900 Voice and GPRS 1900 1 slot
WCDMA Band II RMC
WCDMA Band V RMC

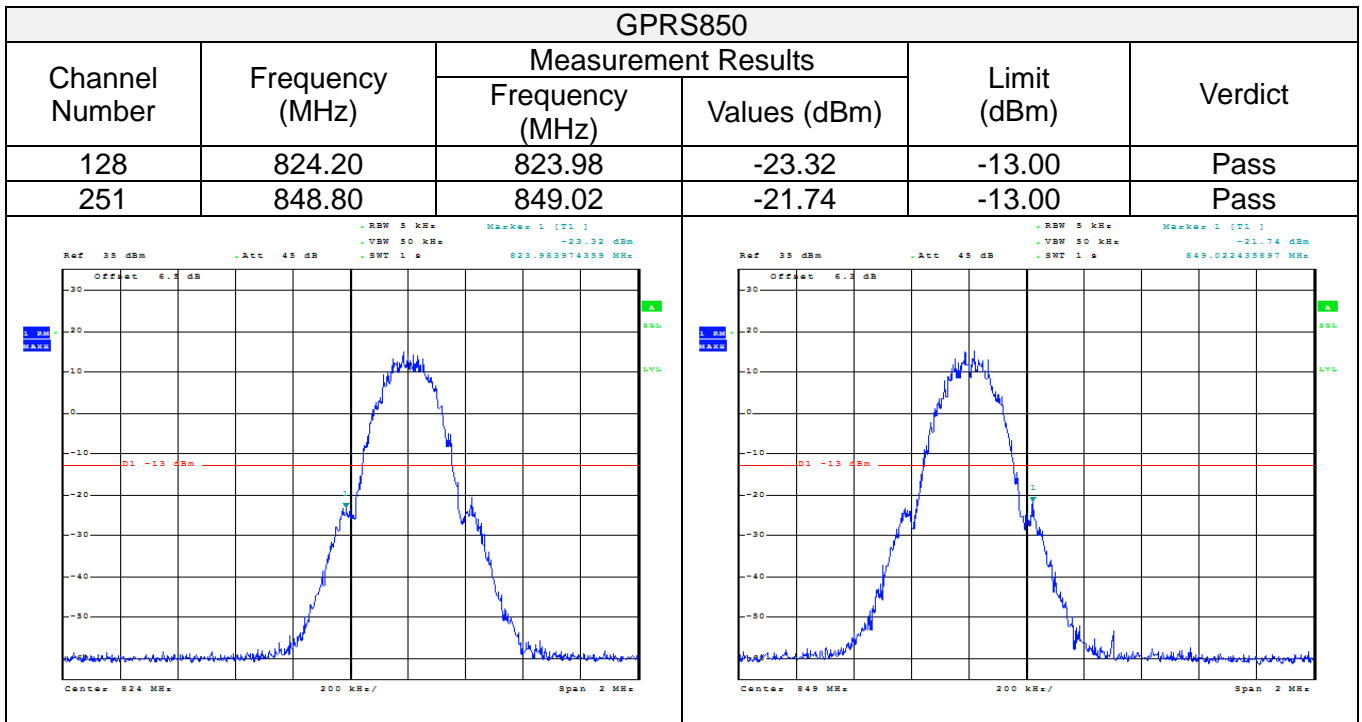
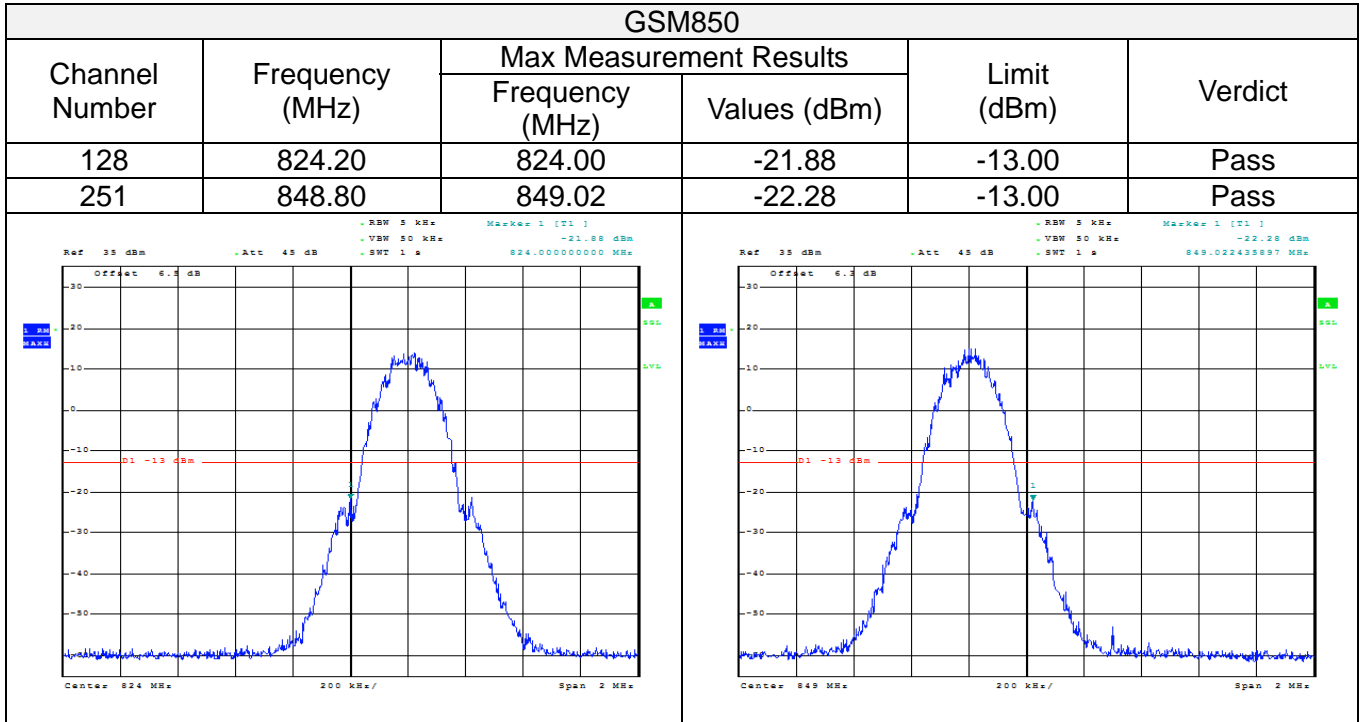

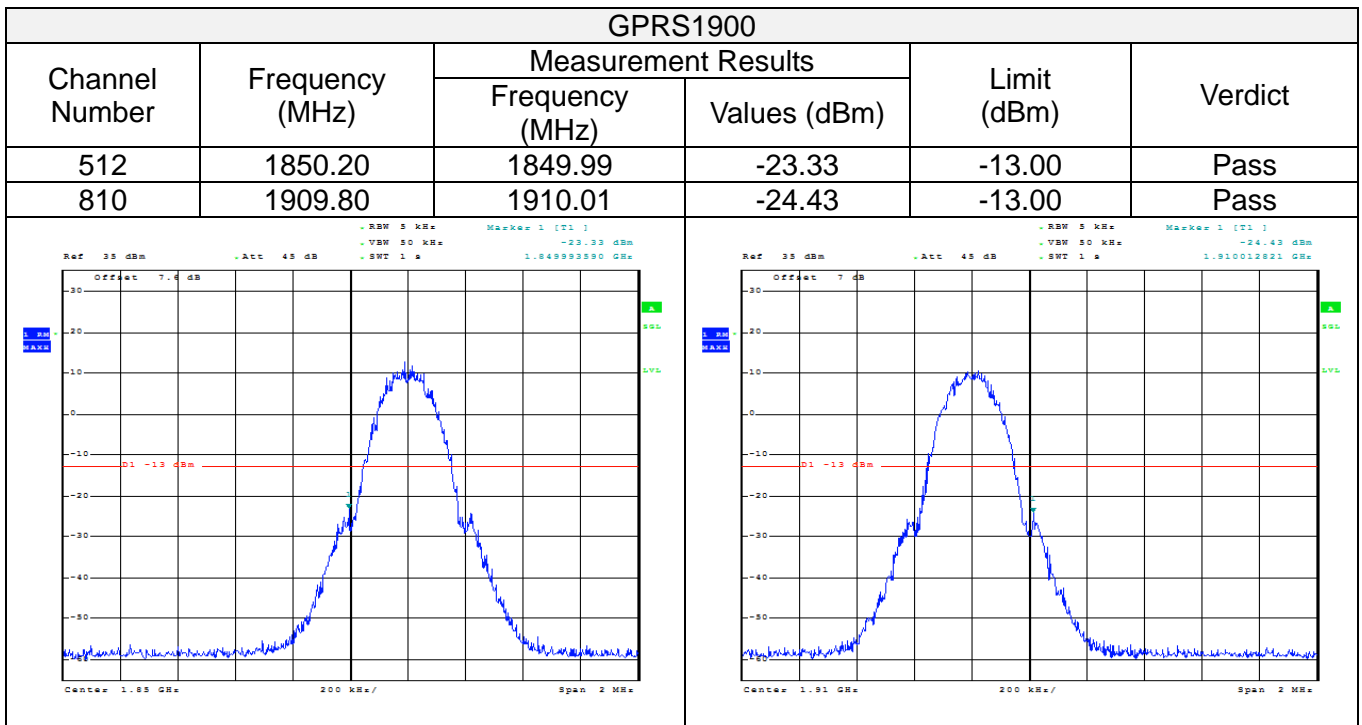
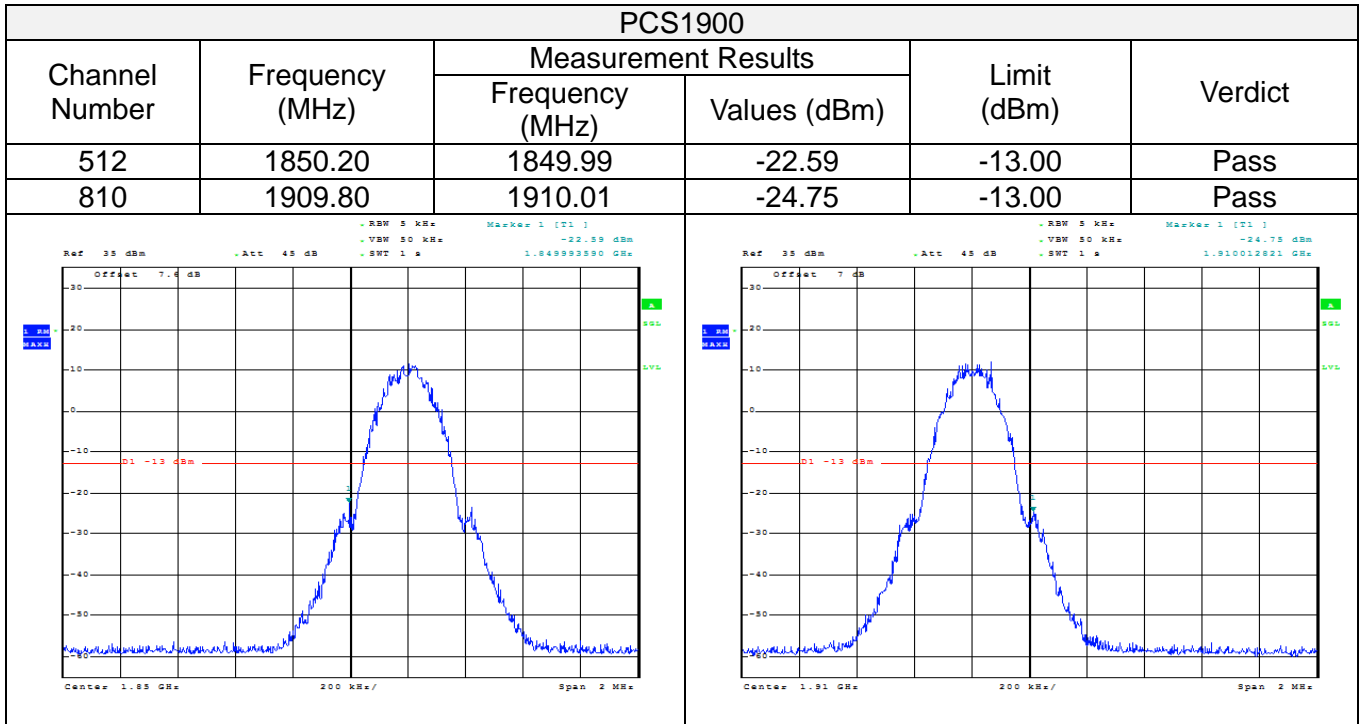

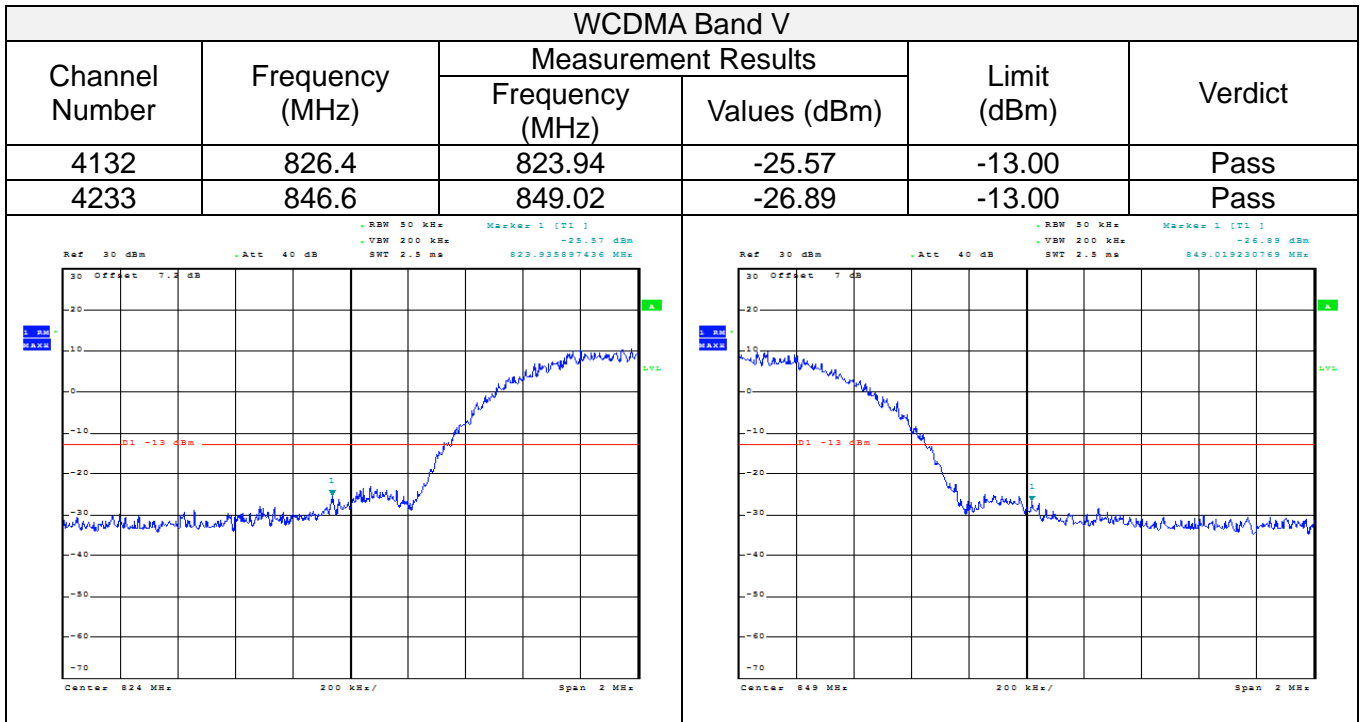
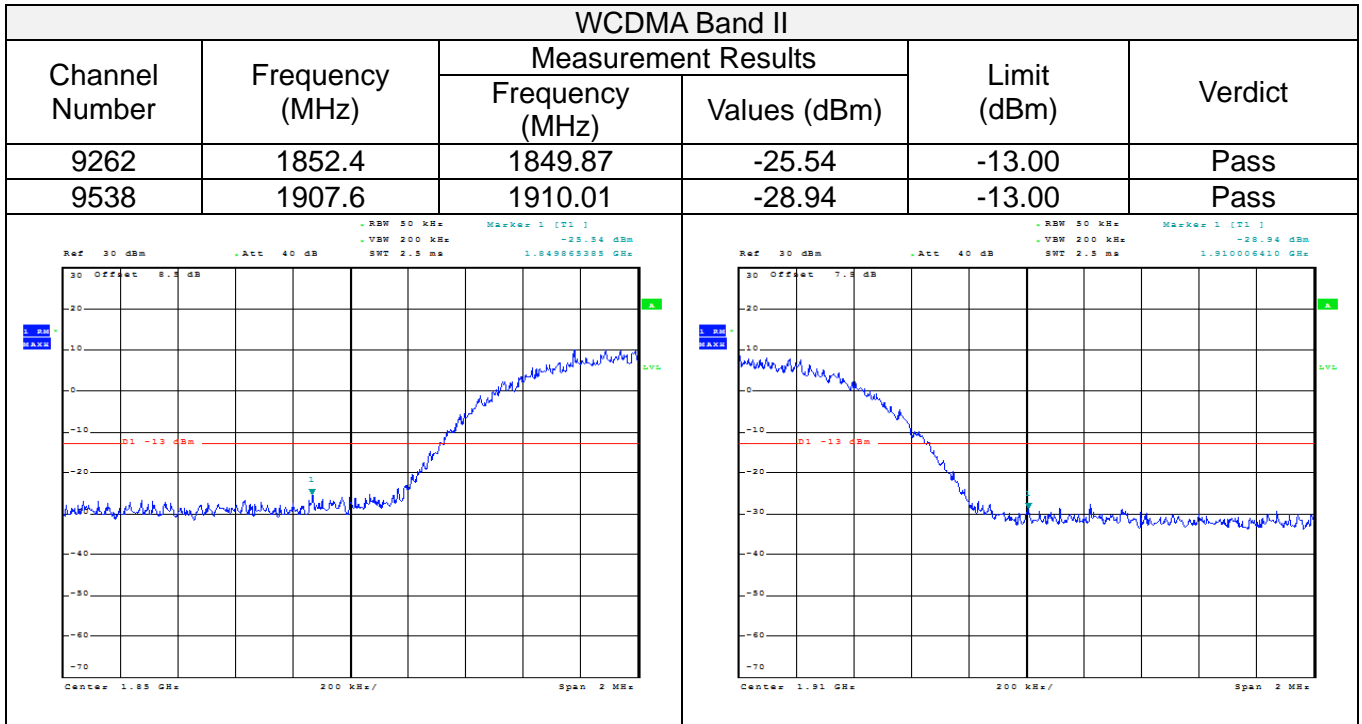

3.5. Radiated Power Measurement

LIMIT

GSM850/WCDMA Band V: 7W ERP

PCS1900/WCDMA Band II: 2W EIRP

TEST CONFIGURATION

For the actual test configuration, please refer to the related Item –EUT Test Photos.

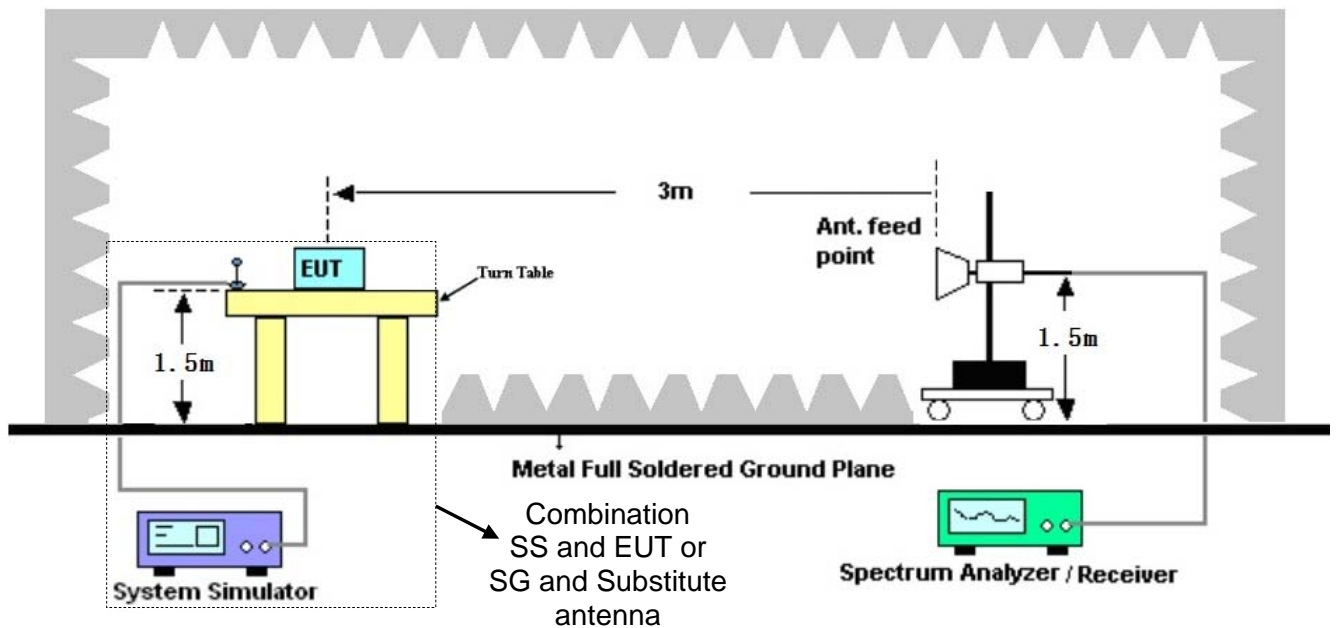
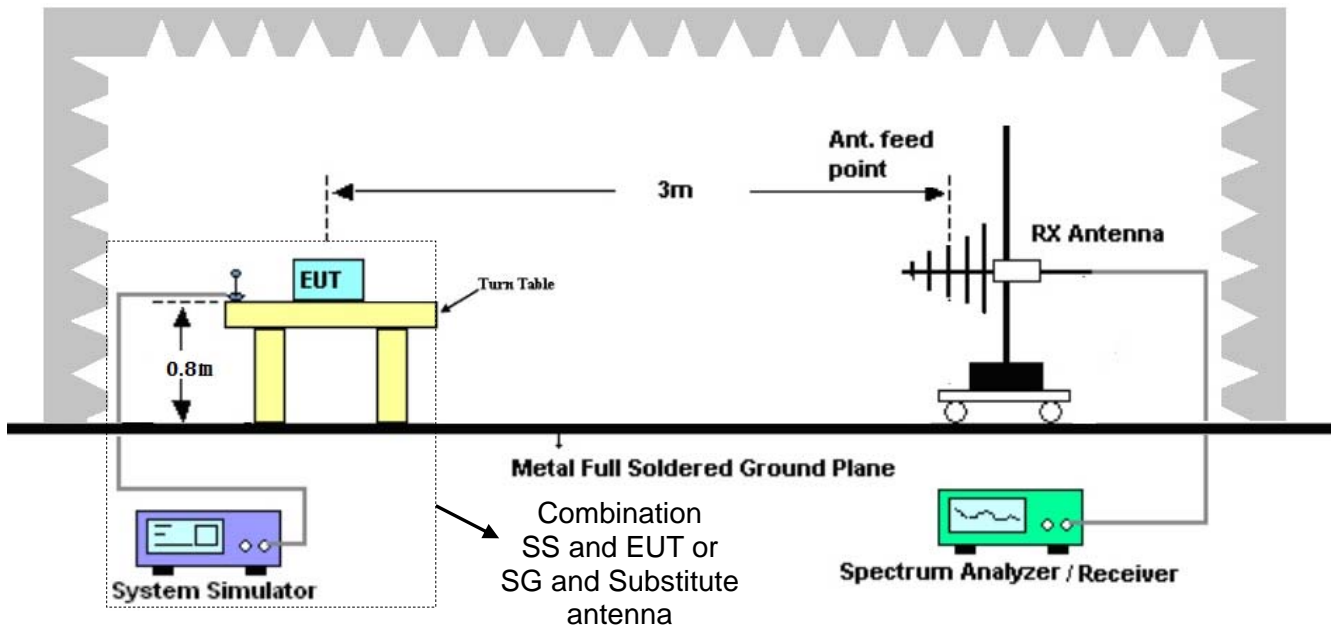

TEST PROCEDURE

1. For below 1GHz test, The EUT was placed on a turn table which is 0.8m above ground plane, for Above 1GHz test, The EUT was placed on a turn table which is 1.5m above ground plane. A receiving antenna was placed on the antenna mast 3 meters from the EUT for emission measurements. Detected emissions were maximized at each frequency by rotating the EUT through 360° and adjusting the receiving antenna polarization. The radiated emission measurements of all transmit frequencies in three channels (High, Middle, Low) were measured with peak detector.
1. A log-periodic antenna or double-ridged waveguide horn antenna shall be substituted in place of the EUT. The log-periodic antenna will be driven by a signal generator and the level will be adjusted till the same power value on the spectrum analyzer or receiver. The level of the spurious emissions can be calculated through the level of the signal generator, cable loss, the gain of the substitution antenna and the reading of the spectrum analyzer or receiver.
2. The EUT is then put into continuously transmitting mode at its maximum power level during the test. Set Test Receiver or Spectrum RBW=1MHz, VBW=3MHz, and the maximum value of the receiver should be recorded as (Pr).
3. The EUT shall be replaced by a substitution antenna. In the chamber, an substitution antenna for the frequency band of interest is placed at the reference point of the chamber. An RF Signal source for the frequency band of interest is connected to the substitution antenna with a cable that has been constructed to not interfere with the radiation pattern of the antenna. A power (PMea) is applied to the input of the substitution antenna, and adjusts the level of the signal generator output until the value of the receiver reach the previously recorded (Pr). The power of signal source (PMea) is recorded. The test should be performed by rotating the test item and adjusting the receiving antenna polarization.
4. An amplifier should be connected to the Signal Source output port. And the cable should be connecting between the Amplifier and the Substitution Antenna. The cable loss (Pcl), the Substitution Antenna Gain (Ga) and the Amplifier Gain (PAg) should be recorded after test.
5. The measurement results are obtained as described below:
$$\text{Power(EIRP)} = \text{PMea} - \text{PAg} - \text{Pcl} + \text{Ga}$$

We used N5182A microwave signal generator which signal level can up to 33dBm,so we not used power Amplifier for substitution test; The measurement results are amend as described below:
$$\text{Power(EIRP)} = \text{PMea} - \text{Pcl} + \text{Ga}$$
6. This value is EIRP since the measurement is calibrated using an antenna of known gain (2.15 dBi) and known input power.
ERP can be calculated from EIRP by subtracting the gain of the dipole, $\text{ERP} = \text{EIRP} - 2.15\text{dBi}$.

TEST RESULTS

Remark:

1. By preliminary testing and verifying three axis (X, Y and Z) position of EUT transmitted status, it was found that "Z axis" position was the worst, and test data recorded in this report.
2. we test all modulation type and record worst case as follows.

GSM850 Voice and GPRS 850 1 slot
GSM 1900 Voice and GPRS 1900 1 slot
WCDMA Band II RMC
WCDMA Band V RMC

GSM:

Mode	Channel	Antenna Pol.	ERP	Limit (dBm)	Result
GSM850 (GMSK)	128	V	32.87	38.45	Pass
		H	27.46		
	190	V	32.71		
		H	28.02		
	251	V	33.04		
		H	28.49		
GPRS850 (GMSK)	128	V	31.75	38.45	Pass
		H	26.46		
	190	V	31.46		
		H	27.58		
	251	V	31.89		
		H	27.38		

Mode	Channel	Antenna Pol.	EIRP	Limit (dBm)	Result
PCS1900 (GMSK)	512	V	29.14	33.01	Pass
		H	27.63		
	661	V	29.32		
		H	26.85		
	810	V	29.27		
		H	27.07		
GPRS1900 (GMSK)	512	V	28.98	33.01	Pass
		H	26.75		
	661	V	28.96		
		H	25.81		
	810	V	28.97		
		H	25.97		

WCDMA:

Mode	Channel	Antenna Pol.	EIRP	Limit (dBm)	Result
WCDMA Band II (QPSK)	9262	V	21.12	33.01	Pass
		H	17.94		
	9400	V	21.42		
		H	18.09		
	9538	V	21.19		
		H	17.94		

Mode	Channel	Antenna Pol.	ERP	Limit (dBm)	Result
WCDMA Band V (QPSK)	4132	V	22.86	38.45	Pass
		H	20.47		
	4182	V	22.47		
		H	19.51		
	4233	V	22.52		
		H	20.45		

3.6. Radiated Spurious Emission

LIMIT

-13dBm

TEST CONFIGURATION

For the actual test configuration, please refer to the related Item –EUT Test Photos.

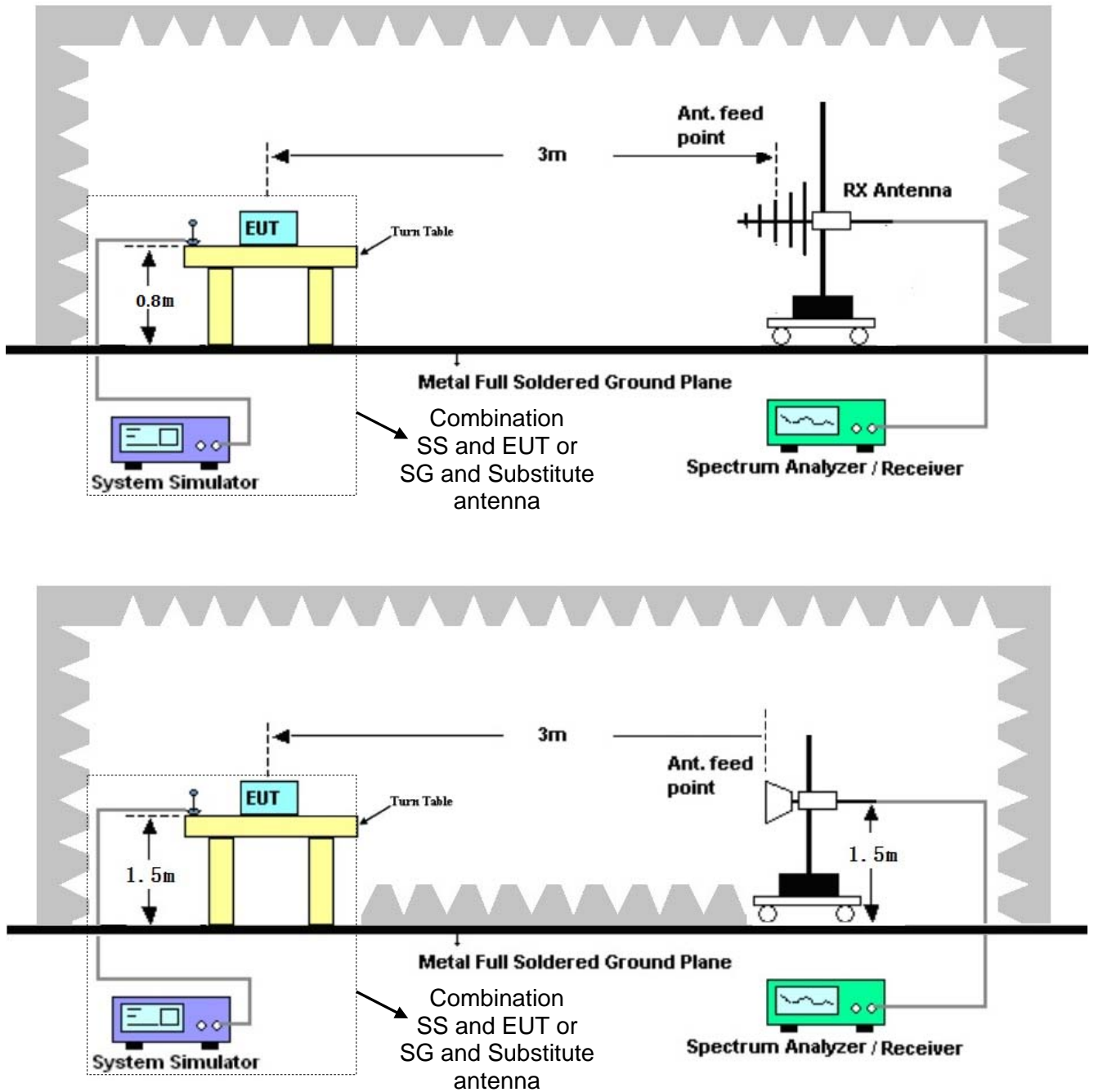

TEST PROCEDURE

2. For below 1GHz test, The EUT was placed on a turn table which is 0.8m above ground plane, for Above 1GHz test, The EUT was placed on a turn table which is 1.5m above ground plane. A receiving antenna was placed on the antenna mast 3 meters from the EUT for emission measurements. Detected emissions were maximized at each frequency by rotating the EUT through 360° and adjusting the receiving antenna polarization. The radiated emission measurements of all transmit frequencies in three channels (High, Middle, Low) were measured with peak detector.
1. A log-periodic antenna or double-ridged waveguide horn antenna shall be substituted in place of the EUT. The log-periodic antenna will be driven by a signal generator and the level will be adjusted till the same power value on the spectrum analyzer or receiver. The level of the spurious emissions can be calculated through the level of the signal generator, cable loss, the gain of the substitution antenna and the reading of the spectrum analyzer or receiver.
2. The EUT is then put into continuously transmitting mode at its maximum power level during the test. Set Test Receiver or Spectrum RBW=1MHz, VBW=3MHz, and the maximum value of the receiver should be recorded as (Pr).
3. The EUT shall be replaced by a substitution antenna. In the chamber, an substitution antenna for the frequency band of interest is placed at the reference point of the chamber. An RF Signal source for the frequency band of interest is connected to the substitution antenna with a cable that has been constructed to not interfere with the radiation pattern of the antenna. A power (PMea) is applied to the input of the substitution antenna, and adjusts the level of the signal generator output until the value of the receiver reach the previously recorded (Pr). The power of signal source (PMea) is recorded. The test should be performed by rotating the test item and adjusting the receiving antenna polarization.
4. An amplifier should be connected to the Signal Source output port. And the cable should be connecting between the Amplifier and the Substitution Antenna. The cable loss (Pcl), the Substitution Antenna Gain (Ga) and the Amplifier Gain (PAg) should be recorded after test.
5. The measurement results are obtained as described below:
Power(EIRP)=PMea- PAg - Pcl + Ga
We used SMF100A microwave signal generator which signal level can up to 33dBm,so we not used power Amplifier for substitution test; The measurement results are amend as described below:
Power(EIRP)=PMea- Pcl + Ga
6. This value is EIRP since the measurement is calibrated using an antenna of known gain (2.15 dBi) and known input power.
ERP can be calculated from EIRP by subtracting the gain of the dipole, ERP = EIRP-2.15dBi.
7. Test frequency range should extend to 10th harmonic of highest fundamental frequency.

TEST RESULTS

Remark:

1. By preliminary testing and verifying three axis (X, Y and Z) position of EUT transmitted status, it was found that “Z axis” position was the worst, and test data recorded in this report.
2. We test all modulation type and record worst case at Voice mode.
3. we test all modulation type and record worst case as follows.

GSM850 Voice
GSM 1900 Voice
WCDMA Band II RMC
WCDMA Band V RMC

GSM850					
Channel	Frequency (MHz)	Spurious Emission		Limit (dBm)	Result
		Polarization	Level (dBm)		
128	1648.40	Vertical	-37.29	-13.00	Pass
	2472.60	Vertical	-42.40		
	3296.80	Vertical	-48.51		
	4121.00	Vertical	-54.62		
	4945.20	Vertical	---		
	1648.40	Horizontal	-39.34	-13.00	Pass
	2472.60	Horizontal	-44.45		
	3296.80	Horizontal	-50.56		
	4121.00	Horizontal	-56.67		
	4945.20	Horizontal	---		
190	1673.20	Vertical	-37.84	-13.00	Pass
	2509.80	Vertical	-42.95		
	3346.40	Vertical	-49.06		
	4183.00	Vertical	-55.17		
	5019.60	Vertical	---		
	1673.20	Vertical	-38.82	-13.00	Pass
	2509.80	Horizontal	-43.93		
	3346.40	Horizontal	-50.04		
	4183.00	Horizontal	-56.15		
	5019.60	Horizontal	---		
251	1697.60	Vertical	-37.71	-13.00	Pass
	2546.40	Vertical	-42.82		
	3395.20	Vertical	-48.93		
	4244.00	Vertical	-55.04		
	5092.80	Vertical	---		
	1697.60	Horizontal	-39.18	-13.00	Pass
	2546.40	Horizontal	-44.29		
	3395.20	Horizontal	-50.40		
	4244.00	Horizontal	-56.51		
	5092.80	Horizontal	---		

Remark :

1. The emission behavior belongs to narrowband spurious emission.
2. Remark"---" means that the emission level is too low to be measured
3. The emission levels of below 1 GHz are very lower than the limit and not show in test report.

PCS1900					
Channel	Frequency (MHz)	Spurious Emission		Limit (dBm)	Result
		Polarization	Level (dBm)		
512	3700.40	Vertical	-36.28	-13.00	Pass
	5550.60	Vertical	-41.39		
	7400.80	Vertical	-47.50		
	9251.00	Vertical	-53.61		
	11101.20	Vertical	---		
	3700.40	Horizontal	-38.33	-13.00	Pass
	5550.60	Horizontal	-43.44		
	7400.80	Horizontal	-49.55		
	9251.00	Horizontal	-55.66		
	11101.20	Horizontal	---		
661	3760.00	Vertical	-36.83	-13.00	Pass
	5640.00	Vertical	-41.94		
	7520.00	Vertical	-48.05		
	9400.00	Vertical	-54.16		
	11280.00	Vertical	---		
	3760.00	Horizontal	-37.33	-13.00	Pass
	5640.00	Horizontal	-42.44		
	7520.00	Horizontal	-48.55		
	9400.00	Horizontal	-54.66		
	11280.00	Horizontal	---		
810	3819.60	Vertical	-36.08	-13.00	Pass
	5729.40	Vertical	-41.19		
	7639.20	Vertical	-47.30		
	9549.00	Vertical	-53.41		
	11458.80	Vertical	---		
	3819.60	Horizontal	-37.53	-13.00	Pass
	5729.40	Horizontal	-42.64		
	7639.20	Horizontal	-48.75		
	9549.00	Horizontal	-54.86		
	11458.80	Horizontal	---		

Remark :

1. The emission behavior belongs to narrowband spurious emission.
2. Remark"---" means that the emission level is too low to be measured
3. The emission levels of below 1 GHz are very lower than the limit and not show in test report.

WCDMA Band II					
Channel	Frequency (MHz)	Spurious Emission		Limit (dBm)	Result
		Polarization	Level (dBm)		
4132	1652.80	Vertical	-39.86	-13.00	Pass
	2479.20	Vertical	-44.97		
	2479.20	Vertical	-51.08		
	3305.60	Vertical	-57.19		
	4132.00	Vertical	---		
	1652.80	Horizontal	-41.91	-13.00	Pass
	2479.20	Horizontal	-47.02		
	2479.20	Horizontal	-53.13		
	3305.60	Horizontal	-59.24		
	4132.00	Horizontal	---		
4182	1673.20	Vertical	-40.41	-13.00	Pass
	2509.80	Vertical	-45.52		
	2509.80	Vertical	-51.63		
	3346.40	Vertical	-57.74		
	4183.00	Vertical	---		
	1673.20	Horizontal	-41.11	-13.00	Pass
	2509.80	Horizontal	-46.22		
	2509.80	Horizontal	-52.33		
	3346.40	Horizontal	-58.44		
	4183.00	Horizontal	---		
4233	1693.20	Vertical	-39.50	-13.00	Pass
	2539.80	Vertical	-44.61		
	2539.80	Vertical	-50.72		
	3386.40	Vertical	-56.83		
	4233.00	Vertical	---		
	1693.20	Horizontal	-41.49	-13.00	Pass
	2539.80	Horizontal	-46.60		
	2539.80	Horizontal	-52.71		
	3386.40	Horizontal	-58.82		
	4233.00	Horizontal	---		

Remark :

1. The emission behavior belongs to narrowband spurious emission.
2. Remark"---" means that the emission level is too low to be measured
3. The emission levels of below 1 GHz are very lower than the limit and not show in test report.

WCDMA Band V					
Channel	Frequency (MHz)	Spurious Emission		Limit (dBm)	Result
		Polarization	Level (dBm)		
4132	1652.80	Vertical	-39.21	-13.00	Pass
	2479.20	Vertical	-44.32		
	2479.20	Vertical	-50.43		
	3305.60	Vertical	-56.54		
	4132.00	Vertical	---		
	1652.80	Horizontal	-41.26	-13.00	Pass
	2479.20	Horizontal	-46.37		
	2479.20	Horizontal	-52.48		
	3305.60	Horizontal	-58.59		
	4132.00	Horizontal	---		
4182	1673.20	Vertical	-39.76	-13.00	Pass
	2509.80	Vertical	-44.87		
	2509.80	Vertical	-50.98		
	3346.40	Vertical	-57.09		
	4183.00	Vertical	---		
	1673.20	Horizontal	-40.22	-13.00	Pass
	2509.80	Horizontal	-45.33		
	2509.80	Horizontal	-51.44		
	3346.40	Horizontal	-57.55		
	4183.00	Horizontal	---		
4233	1693.20	Vertical	-39.12	-13.00	Pass
	2539.80	Vertical	-44.23		
	2539.80	Vertical	-50.34		
	3386.40	Vertical	-56.45		
	4233.00	Vertical	---		
	1693.20	Horizontal	-41.00	-13.00	Pass
	2539.80	Horizontal	-46.11		
	2539.80	Horizontal	-52.22		
	3386.40	Horizontal	-58.33		
	4233.00	Horizontal	---		

Remark :

4. The emission behavior belongs to narrowband spurious emission.
1. Remark"---" means that the emission level is too low to be measured
2. The emission levels of below 1 GHz are very lower than the limit and not show in test report.

3.7. Frequency stability

LIMIT

Cellular Band: $\pm 2.5\text{ppm}$ PCS Band: Within the authorized frequency block

TEST CONFIGURATION

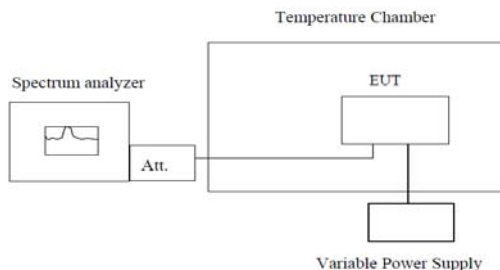

Note : Measurement setup for testing on Antenna connector

TEST PROCEDURE

1. The equipment under test was connected to an external DC power supply and input rated voltage.
2. RF output was connected to a frequency counter or spectrum analyzer via feed through attenuators.
3. The EUT was placed inside the temperature chamber.
4. Set the spectrum analyzer RBW low enough to obtain the desired frequency resolution and measure EUT 25°C operating frequency as reference frequency.
5. Turn EUT off and set the chamber temperature to -30°C. After the temperature stabilized for approximately 30 minutes recorded the frequency.
6. Repeat step measure with 10°C increased per stage until the highest temperature of +50°C reached.
7. Reduce the input voltage to specified extreme voltage variation (+/- 15%) and endpoint, record the maximum frequency change.

TEST RESULTS

Remark:

1. According to manufacture, the battery operation range: 3.4V - 4.25V
2. we test all modulation type and record worst case as follows.

GSM850 Voice
GSM 1900 Voice
WCDMA Band II RMC
WCDMA Band V RMC



Reference Frequency: GSM850 Middle channel=190 channel=836.6MHz					
Voltage (V)	Temperature (°C)	Frequency error		Limit (ppm)	Result
		Hz	ppm		
3.70	-30	-17	-0.02	2.5	Pass
	-20	-15	-0.02		
	-10	-10	-0.01		
	0	-14	-0.02		
	10	-10	-0.01		
	20	-15	-0.02		
	30	-16	-0.02		
	40	-17	-0.02		
	50	-14	-0.02		
4.25	25	-13	-0.02		
End point 3.40	25	-15	-0.02		
Reference Frequency: PCS1900 Middle channel=661 channel=1880MHz					
Voltage (V)	Temperature (°C)	Frequency error		Limit (ppm)	Result
		Hz	ppm		
3.70	-30	-21	-0.01	2.5	Pass
	-20	-18	-0.01		
	-10	-19	-0.01		
	0	-21	-0.01		
	10	-28	-0.01		
	20	-21	-0.01		
	30	-18	-0.01		
	40	-19	-0.01		
	50	-21	-0.01		
4.25	25	-24	-0.01		
End point 3.40	25	-20	-0.01		

Reference Frequency: WCDMA Band II Middle channel=9400 channel=1880MHz					
Voltage (V)	Temperature (°C)	Frequency error		Limit (ppm)	Result
		Hz	ppm		
3.70	-30	-21	-0.01	2.5	Pass
	-20	-18	-0.01		
	-10	-19	-0.01		
	0	-21	-0.01		
	10	-28	-0.01		
	20	-21	-0.01		
	30	-18	-0.01		
	40	-19	-0.01		
	50	-21	-0.01		
4.25	25	-24	-0.01		
End point 3.40	25	-20	-0.01		

Reference Frequency: WCDMA Band V Middle channel=4182 channel=836.6MHz					
Voltage (V)	Temperature (°C)	Frequency error		Limit (ppm)	Result
		Hz	ppm		
3.70	-30	-18	-0.02	2.5	Pass
	-20	-14	-0.02		
	-10	-12	-0.01		
	0	-14	-0.02		
	10	-18	-0.02		
	20	-14	-0.02		
	30	-13	-0.02		
	40	-10	-0.01		
	50	-14	-0.02		
4.25	25	-17	-0.02		
End point 3.40	25	-19	-0.02		

4. EUT TEST PHOTOS

Radiated Emission

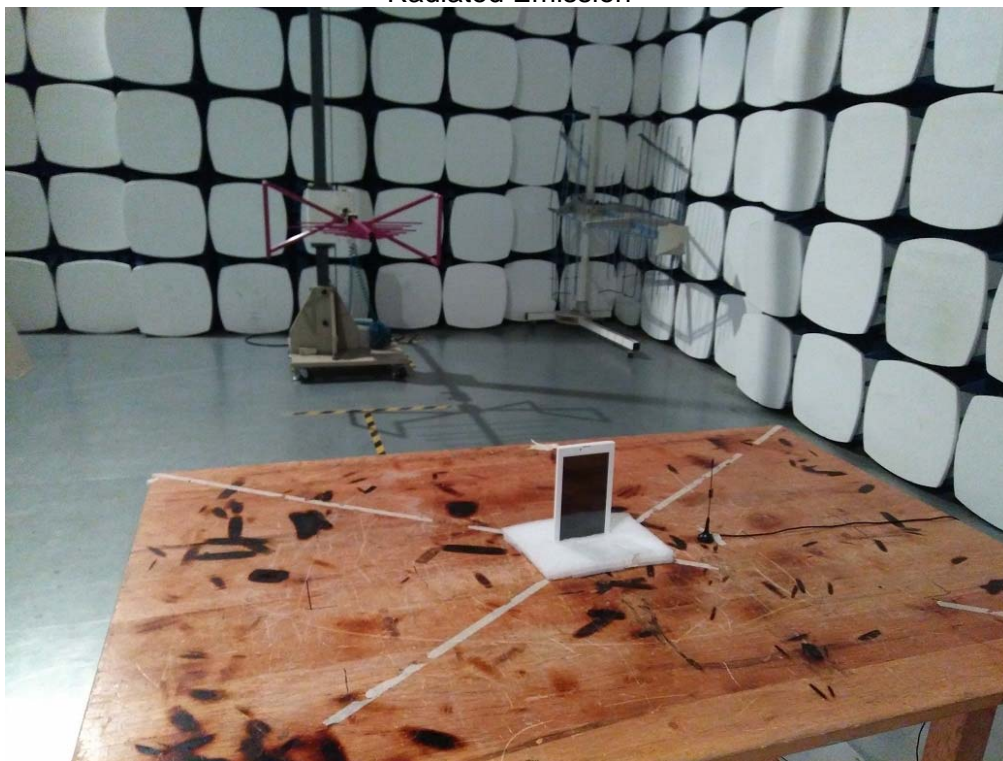



5. PHOTOGRAPHS OF EUT CONSTRUCTIONAL

Please reference to the test report No.: GTI20160197F-1

*****THE END*****