



**Shenzhen GTI Technology Co., Ltd.**

1F,2 Block, Jiaquan Building, Guanlan High-tech Park Baoan District,  
Shenzhen, Guangdong, China.

Tel: +86-755-27559792

Fax: +86-755-86116468

Report No.: GTI20160197F-1

Page 1 of 67

# TEST REPORT

**Product Name** .....: Tablet PC

**Trademark** .....: /

**Model/Type reference** .....: A723G

**List Model:** See the page 6

**FCC ID**.....: 2AEB5-A723

**Test Standards** .....: **FCC Part 15.247: Operation within the bands 902-928 MHz, 2400-2483.5 MHz and 5725-5850 MHz**

**Applicant** .....: AOC

**Address of applicant** .....: 14F-5, NO.258, Liancheng Rd., Zhonghe Dist., New Taipei City, Taiwan

**Date of Receipt** .....: Mar. 05, 2016

**Date of Test Date**.....: Mar. 05, 2016- Mar. 11, 2016

**Data of issue.** .....: Mar. 11, 2016

<b>Test result</b>	<b>Pass *</b>
--------------------	---------------

\* In the configuration tested, the EUT complied with the standards specified above

GENERAL DESCRIPTION OF EUT	
Equipment:	Tablet PC
Model Name:	A723G
Manufacturer:	Shenzhen KTC Technology Co., Ltd.
Manufacturer Address:	Northern Wuhe Road, Gangtou,Buji, Longgang,Shenzhen, China
Power Rating:	DC 3.7V from 2700mAh by rechargeable battery DC 5.0V from Adapter

Compiled By:

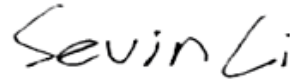

---

(Sevin Li)

Reviewed By:

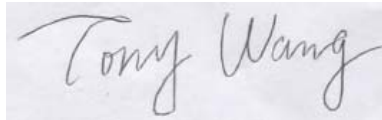

---

(Tony Wang)

Approved By:

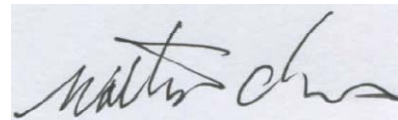

---

(Walter Chen)

This test report consists of 67 pages in total. It may be duplicated completely for legal use with the approval of the applicant. It should not be reproduced except in full, without the written approval of our laboratory. The client should not use it to claim product endorsement by GTI. The test results in the report only apply to the tested sample. The test report shall be invalid without all the signatures of compiler, reviewer and approver. Any objections must be raised to GTI within 15 days since the date when the report is received. It will not be taken into consideration beyond this limit.



Table of Contents

Page

- 1. SUMMARY..... 4
  - 1.1. TEST STANDARDS.....4
  - 1.2. TEST DESCRIPTION.....4
  - 1.3. TEST FACILITY .....5
  - 1.4. MEASUREMENT UNCERTAINTY .....5
- 2. GENERAL INFORMATION..... 6
  - 2.1. ENVIRONMENTAL CONDITIONS .....6
  - 2.2. GENERAL DESCRIPTION OF EUT .....6
  - 2.3. DESCRIPTION OF TEST MODES .....7
  - 2.4. MEASUREMENT INSTRUMENTS LIST .....7
- 3. TEST CONDITIONS AND RESULTS ..... 9
  - 3.1. CONDUCTED EMISSION (AC MAIN) .....9
  - 3.2. RADIATED EMISSION .....14
  - 3.3. MAXIMUM PEAK OUTPUT POWER .....24
  - 3.4. 20dB BANDWIDTH.....28
  - 3.5. BAND EDGE .....32
  - 3.6. FREQUENCY SEPARATION .....38
  - 3.7. NUMBER OF HOPPING FREQUENCY.....40
  - 3.8. TIME OF OCCUPANCY (DWELL TIME).....42
  - 3.9. SPURIOUS RF CONDUCTED EMISSION.....46
  - 3.10. PSEUDORANDOM FREQUENCY HOPPING SEQUENCE.....56
  - 3.11. ANTENNA REQUIREMENT.....57
- 4. EUT TEST PHOTO ..... 58
- 5. PHOTOGRAPHS OF EUT CONSTRUCTIONAL ..... 59

# 1. SUMMARY

## 1.1. Test Standards

The tests were performed according to following standards:

[FCC Rules Part 15.247](#): Frequency Hopping, Direct Spread Spectrum and Hybrid Systems that are in operation within the bands of 902-928 MHz, 2400-2483.5 MHz, and 5725-5850 MHz

[ANSI C63.10-2013](#): American National Standard for Testing Unlicensed Wireless Devices

## 1.2. Test Description

FCC PART 15 15.247		
FCC Part 15.207	AC Power Conducted Emission	PASS
FCC Part 15.247(a)(1)(i)	20dB Bandwidth	PASS
FCC Part 15.247(d)	Spurious RF Conducted Emission	PASS
FCC Part 15.247(b)	Maximum Peak Output Power	PASS
FCC Part 15.247(b)	Pseudorandom Frequency Hopping Sequence	PASS
FCC Part 15.247(a)(1)(iii)	Number of hopping frequency& Time of Occupancy	PASS
FCC Part 15.247(a)(1)	Frequency Separation	PASS
FCC Part 15.205/15.209	Radiated Emissions	PASS
FCC Part 15.247(d)	Band Edge Compliance of RF Emission	PASS
FCC Part 15.203/15.247 (b)	Antenna Requirement	PASS

Remark: The measurement uncertainty is not included in the test result.

### 1.3. Test Facility

#### 1.3.1 Address of the test laboratory

##### Shenzhen General Testing & Inspection Technology Co., Ltd.

Add: 1F, 2 Block, Jiaquan Building, Guanlan High-tech Park Baoan District, Shenzhen, Guangdong, China

#### 1.3.2 Laboratory accreditation

The test facility is recognized, certified, or accredited by the following organizations:

##### IC Registration No.: 9783A

The 3m alternate test site of Shenzhen GTI Technology Co., Ltd. EMC Laboratory has been registered by Certification and Engineer Bureau of Industry Canada for the performance of with Registration NO.: 9783A on Aug, 2011.

##### FCC-Registration No.: 214666

Shenzhen GTI Technology Co., Ltd. EMC Laboratory has been registered and fully described in a report filed with the (FCC) Federal Communications Commission. The acceptance letter from the FCC is maintained in our files. Registration 214666, Sep 19, 2011

### 1.4. Measurement Uncertainty

The data and results referenced in this document are true and accurate. The reader is cautioned that there may be errors within the calibration limits of the equipment and facilities. The measurement uncertainty was calculated for all measurements listed in this test report acc. to CISPR 16 - 4 Specification for radio disturbance and immunity measuring apparatus and methods – Part 4: Uncertainty in EMC Measurements and is documented in the Shenzhen General Testing & Inspection Technology Co., Ltd quality system acc. to DIN EN ISO/IEC 17025. Furthermore, component and process variability of devices similar to that tested may result in additional deviation. The manufacturer has the sole responsibility of continued compliance of the device.

Hereafter the best measurement capability for General Testing & Inspection laboratory is reported:

Test Items	Measurement Uncertainty	Notes
Transmitter power conducted	0.57 dB	(1)
Transmitter power Radiated	2.20 dB	(1)
Conducted spurious emission 9KHz-40 GHz	1.60 dB	(1)
Radiated spurious emission 9KHz-40 GHz	2.20 dB	(1)
Conducted Emission 9KHz-30MHz	3.39 dB	(1)
Radiated Emission 30~1000MHz	4.24 dB	(1)
Radiated Emission 1~18GHz	5.16 dB	(1)
Radiated Emission 18-40GHz	5.54 dB	(1)
Occupied Bandwidth	-----	(1)

(1) This uncertainty represents an expanded uncertainty expressed at approximately the 95% confidence level using a coverage factor of k=1.96.

## 2. GENERAL INFORMATION

### 2.1. Environmental conditions

During the measurement the environmental conditions were within the listed ranges:

Temperature:	15~35°C
Relative Humidity:	30~60 %
Air Pressure:	950~1050mba

### 2.2. General Description of EUT

Product Name:	Tablet PC
Model/Type reference:	A723G
List Model:	700P***, &&700*****
Model difference:	700P*** (1st* could be 0-99 or A-Z, means different client code; 2nd* could be 0-99 or A-Z or blank, stands for the shape or color of enclosure, no impact on Products safety and EMC characteristics); &&700*****(& could be “A-Z” or “a-z” , * could be “0-99” , “A-Z” , “a-z” , “-” , “/” or blank, means different client code, no impact on Products safety and EMC characteristics
Power supply:	DC 3.7V from battery, 2700mAh Battery model: 338085
Adapter1 information:	Model: EP29-05015WULZ Input: 100-240, 50/60Hz, 0.35Max Output: 5V $\overline{=}$ 1500mA
Adapter2 information:	Model: SA69-050150U Input: 100-240, 50/60Hz, 0.30Max Output: 5V $\overline{=}$ 1500mA
Hardware version:	V10
Software version:	V5.1
<b>Bluetooth 2.1</b>	
Version:	Supported BT2.1+EDR
Modulation:	GFSK, $\pi$ /4DQPSK, 8DPSK
Operation frequency:	2402MHz~2480MHz
Channel number:	79
Channel separation:	1MHz
Antenna type:	FPCB Antenna
Antenna gain:	1.2dBi

Note: For a more detailed features description, please refer to the manufacturer’s specifications or the User’s Manual.

### 2.3. Description of Test Modes

The Applicant provides communication tools software (Phone Tool V5.0.0.0) to control the EUT for staying in continuous transmitting (Duty Cycle more than 98%) and receiving mode for testing .There are 79 channels provided to the EUT. Channel 00/39/78 was selected to test. When the test, fully-charged battery is used

#### Operation Frequency :

Channel	Frequency (MHz)
<b>00</b>	<b>2402</b>
2	2403
:	:
38	2440
<b>39</b>	<b>2441</b>
40	2442
:	:
77	2479
<b>78</b>	<b>2480</b>

### 2.4. Measurement Instruments List

Maximum Peak Output Power / Band Edge Compliance of RF Emission / Spurious RF Conducted Emission /Hoping Require/ 20dB bandwidth					
Item	Test Equipment	Manufacturer	Model No.	Serial No.	Calibrated until
1	Spectrum Analyzer	Rohde & Schwarz	FSU	100105	Jan 04,2017
2	RF Cable	Schwarzbeck	AH32D4	SF0150	Jan 04,2017
3	Temporary Antenna connector	Schwarzbeck	SMA24D	ED1201	Jan 04,2017
Note: The temporary antenna connector is soldered on the PCB board in order to perform conducted tests and this temporary antenna connector is listed in the equipment list.					

Conducted Emission					
Item	Test Equipment	Manufacturer	Model No.	Serial No.	Calibrate until
1	LISN	R&S	ENV216	101112	Jan 04,2017
2	LISN	R&S	ENV216	101113	Jan 04,2017
3	EMI Test Receiver	R&S	ESCI	100920	Jan 04,2017
4	Cable	Schwarzbeck	AK9515E	33156	Jan 04,2017

Radiated Emission					
Item	Test Equipment	Manufacturer	Model No.	Serial No.	Calibrated until
1	EMI Test Receiver	R&S	ESCI	100967	Jan 04,2017
2	High pass filter	micro-tranics	HPM50111	34202	Jan 04,2017
3	Log-Bicon Antenna	Schwarzbeck	CBL6141A	4180	Jan 04,2017
4	Ultra-Broadband Antenna	ShwarzBeck	BBHA9170	25841	Jan 07,2017
5	Loop Antenna	LAPLAC	RF300	9138	Jan 07,2017
6	Spectrum Analyzer	Rohde & Schwarz	FSU	100105	Jan 04,2017
7	Horn Antenna	Schwarzbeck	BBHA 9120D	648	Jan 07,2017
8	Pre-Amplifier	HP	8447D	1937A03050	Jan 04,2017
9	Pre-Amplifier	EMCI	EMC05183 5	980075	Jan 04,2017
10	Antenna Mast	UC	UC3000	N/A	N/A
11	Turn Table	UC	UC3000	N/A	N/A
12	Cable Below 1GHz	Schwarzbeck	AK9515E	33155	Jan 04,2017
13	Cable Above 1GHz	Hubersuhner	SUCOFLEX1 02	DA1580	Jan 04,2017

Note: 1. The Cal.Interval was one year.

2. The cable loss has calculated in test result which connection between each test instruments.



### 3. TEST CONDITIONS AND RESULTS

#### 3.1. Conducted Emission (AC Main)

##### LIMIT

FCC CFR Title 47 Part 15 Subpart C Section 15.207

Frequency range (MHz)	Limit (dBuV)	
	Quasi-peak	Average
0.15-0.5	66 to 56*	56 to 46*
0.5-5	56	46
5-30	60	50

\* Decreases with the logarithm of the frequency.

##### TEST CONFIGURATION

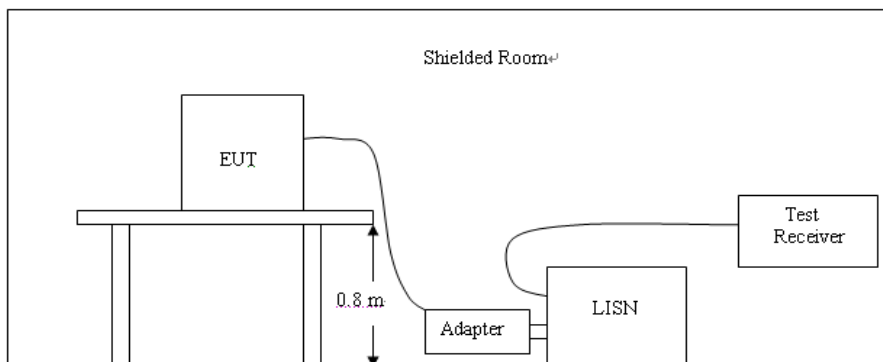

##### TEST PROCEDURE

1. The equipment was set up as per the test configuration to simulate typical actual usage per the user’s manual. The EUT is a tabletop system; a wooden table with a height of 0.8 meters is used and is placed on the ground plane as per ANSI C63.10-2013.
2. Support equipment, if needed, was placed as per ANSI C63.10-2013
3. All I/O cables were positioned to simulate typical actual usage as per ANSI C63.10-2013
4. The EUT received DC5V power from the adapter, the adapter received AC120V/60Hz power through a Line Impedance Stabilization Network (LISN) which supplied power source and was grounded to the ground plane.
5. All support equipments received AC power from a second LISN, if any.
6. The EUT test program was started. Emissions were measured on each current carrying line of the EUT using a spectrum Analyzer / Receiver connected to the LISN powering the EUT. The LISN has two monitoring points: Line 1 (Hot Side) and Line 2 (Neutral Side). Two scans were taken: one with Line 1 connected to Analyzer / Receiver and Line 2 connected to a 50 ohm load; the second scan had Line 1 connected to a 50 ohm load and Line 2 connected to the Analyzer / Receiver.
7. Analyzer / Receiver scanned from 150 KHz to 30MHz for emissions in each of the test modes.
8. During the above scans, the emissions were maximized by cable manipulation.

**TEST RESULTS**

Note: We tested three channels for each mode and recorded worst case at low channel of GFSK Mode.

Adapter: EP29-05015WULZ

LINE

L

**SCAN TABLE: "Vol (9K-30M) FIN-N"**

Short Description: 150K-30M Voltage

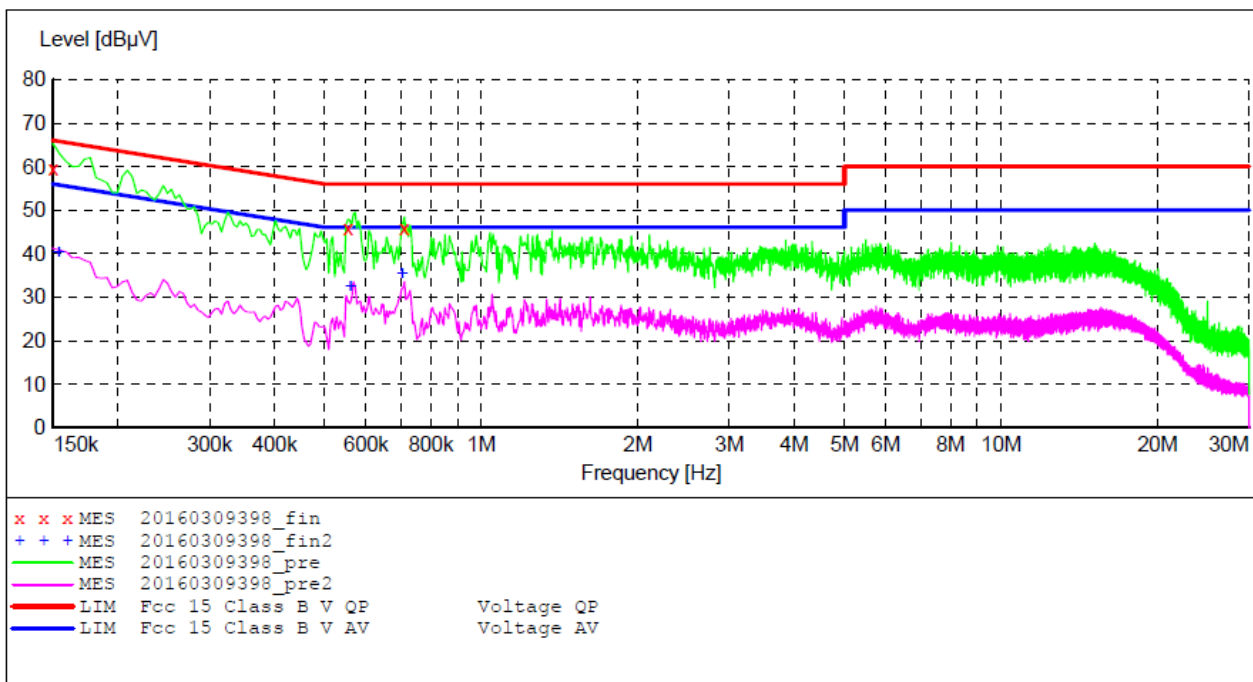

**MEASUREMENT RESULT: "20160309398\_fin"**

3/9/2016 10:14AM

Frequency MHz	Level dBuV	Transd dB	Limit dBuV	Margin dB	Detector	Line	PE
0.150000	59.40	9.8	66	6.6	QP	L1	GND
0.554000	45.70	9.8	56	10.3	QP	L1	GND
0.710000	45.90	9.9	56	10.1	QP	L1	GND

**MEASUREMENT RESULT: "20160309398\_fin2"**

3/9/2016 10:14AM

Frequency MHz	Level dBuV	Transd dB	Limit dBuV	Margin dB	Detector	Line	PE
0.154000	40.10	9.8	56	15.7	AV	L1	GND
0.560000	32.40	9.8	46	13.6	AV	L1	GND
0.704000	35.20	9.9	46	10.8	AV	L1	GND

LINE

N

**SCAN TABLE: "Vo1 (9K-30M) FIN-N"**

Short Description: 150K-30M Voltage

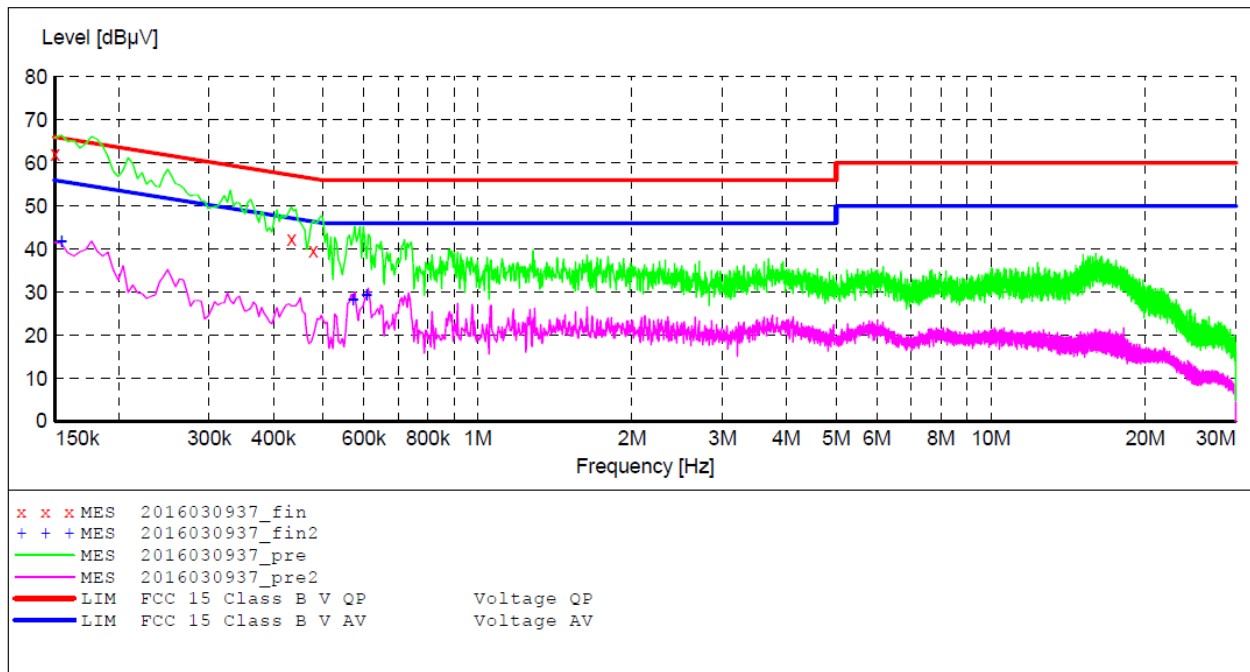

**MEASUREMENT RESULT: "2016030937\_fin"**

3/9/2016 10:12AM

Frequency MHz	Level dBμV	Transd dB	Limit dBμV	Margin dB	Detector	Line	PE
0.150000	62.20	9.5	66	3.8	QP	N	GND
0.433500	42.40	9.5	57	14.8	QP	N	GND
0.478500	39.50	9.5	56	16.9	QP	N	GND

**MEASUREMENT RESULT: "2016030937\_fin2"**

3/9/2016 10:12AM

Frequency MHz	Level dBμV	Transd dB	Limit dBμV	Margin dB	Detector	Line	PE
0.154500	41.70	9.5	56	14.1	AV	N	GND
0.572000	28.40	9.6	46	17.6	AV	N	GND
0.608000	29.40	9.6	46	16.6	AV	N	GND

Adapter: SA69-050150U

LINE

L

**SCAN TABLE: "Vol (9K-30M) FIN-N"**

Short Description: 150K-30M Voltage

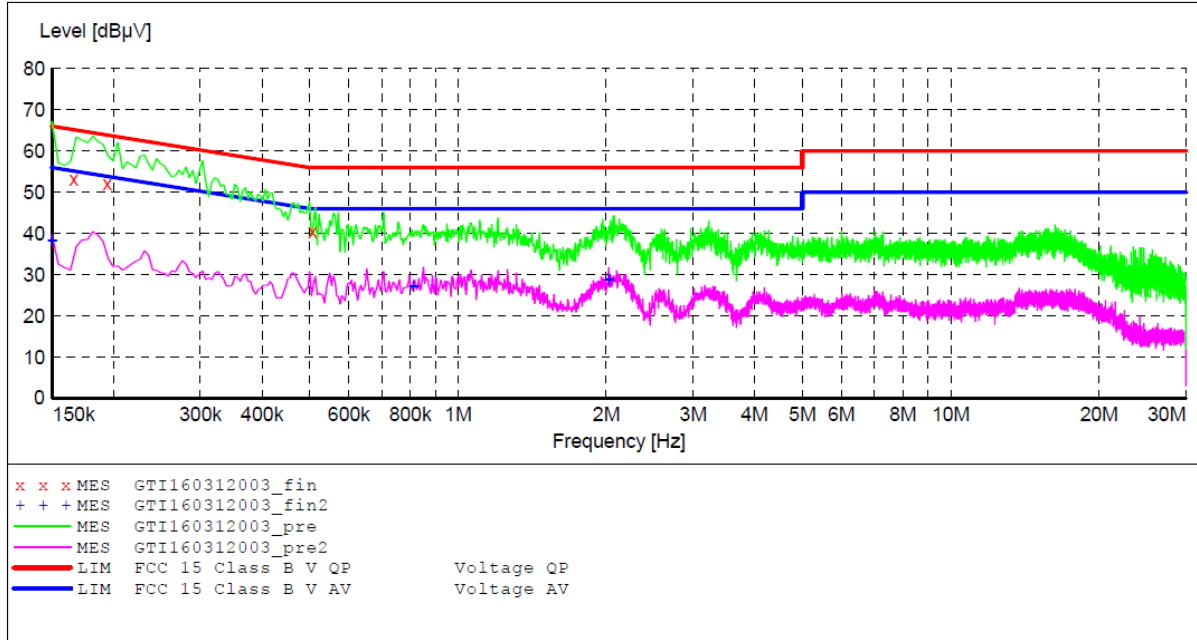

**MEASUREMENT RESULT: "GTI160312003\_fin"**

3/12/2016 9:14AM

Frequency MHz	Level dBµV	Transd dB	Limit dBµV	Margin dB	Detector	Line	PE
0.166000	53.30	9.8	65	11.9	QP	L1	GND
0.194000	52.00	9.7	64	11.9	QP	L1	GND
0.506000	40.50	9.8	56	15.5	QP	L1	GND

**MEASUREMENT RESULT: "GTI160312003\_fin2"**

3/12/2016 9:14AM

Frequency MHz	Level dBµV	Transd dB	Limit dBµV	Margin dB	Detector	Line	PE
0.150000	38.20	9.8	56	17.8	AV	L1	GND
0.812000	27.30	9.9	46	18.7	AV	L1	GND
2.024000	28.90	10.3	46	17.1	AV	L1	GND

LINE

N

**SCAN TABLE: "V01 (9K-30M) FIN-N"**

Short Description: 150K-30M Voltage

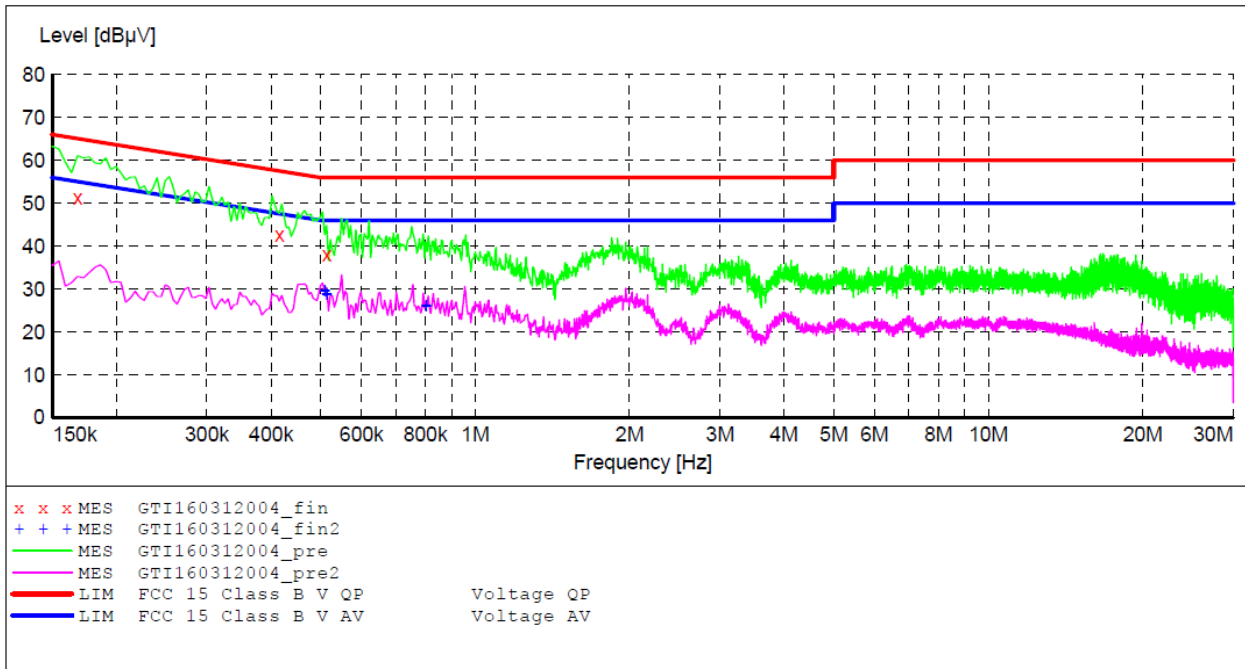

**MEASUREMENT RESULT: "GTI160312004\_fin"**

3/12/2016 9:16AM

Frequency MHz	Level dBµV	Transd dB	Limit dBµV	Margin dB	Detector	Line	PE
0.168000	51.30	9.5	65	13.8	QP	N	GND
0.415500	42.50	9.5	58	15.0	QP	N	GND
0.513500	37.90	9.5	56	18.1	QP	N	GND

**MEASUREMENT RESULT: "GTI160312004\_fin2"**

3/12/2016 9:16AM

Frequency MHz	Level dBµV	Transd dB	Limit dBµV	Margin dB	Detector	Line	PE
0.509000	29.50	9.5	46	16.5	AV	N	GND
0.513500	28.70	9.5	46	17.3	AV	N	GND
0.801500	26.10	9.7	46	19.9	AV	N	GND

## 3.2. Radiated Emission

### Limit

For intentional device, according to § 15.209(a), the general requirement of field strength of radiated emission from intentional radiators at a distance of 3 meters shall not exceed the following table. According to § 15.247(d), in any 100kHz bandwidth outside the frequency band in which the EUT is operating, the radio frequency power that is produced by the intentional radiator shall be at least 20dB below that in the 100kHz bandwidth within the band that contains the highest level of desired power.

The frequency spectrum above 1 GHz for Transmitter was investigated. All emission not reported are much lower than the prescribed limits. Set the RBW=1MHz, VBW=3MHz for Peak Detector while the RBW=1MHz, VBW=10Hz for Average Detector, Readings are both peak and average values. The pre-test have done for the EUT in three axes and found the worst emission at position shown in test setup photos.

Frequency (MHz)	Distance (Meters)	Radiated (dBuV/m)	Radiated ( $\mu$ V/m)
0.009-0.49	3	$20\log(2400/F(\text{KHz}))+40\log(300/3)$	$2400/F(\text{KHz})$
0.49-1.705	3	$20\log(24000/F(\text{KHz}))+40\log(30/3)$	$24000/F(\text{KHz})$
1.705-30	3	$20\log(30)+40\log(30/3)$	30
30-88	3	40.0	100
88-216	3	43.5	150
216-960	3	46.0	200
Above 960	3	54.0	500

### Test Procedure

1. For below 1GHz test, The EUT was placed on a turn table which is 0.8m above ground plane; For Above 1GHz test, The EUT was placed on a turn table which is 1.5m above ground plane;
2. Maximum procedure was performed by raising the receiving antenna from 1m to 4m and rotating the turn table from 0° to 360° to acquire the highest emissions from EUT
3. And also, each emission was to be maximized by changing the polarization of receiving antenna both horizontal and vertical.
4. Repeat above procedures until all frequency measurements have been completed.

Note: For the radiated emission test above 1GHz:

Place the measurement antenna away from each area of the EUT determined to be a source of emissions at the specified measurement distance, while keeping the measurement antenna aimed at the source of emissions at each frequency of significant emissions, with polarization oriented for maximum response. The measurement antenna may have to be higher or lower than the EUT, depending on the radiation pattern of the emission and staying aimed at the emission source for receiving the maximum signal. The final measurement antenna elevation shall be that which maximizes the emissions. The measurement antenna elevation for maximum emissions shall be restricted to a range of heights of from 1 m to 4 m above the ground or reference ground plane.

**Field Strength Calculation**

The field strength is calculated by adding the Antenna Factor and Cable Factor and subtracting the Amplifier Gain and Duty Cycle Correction Factor (if any) from the measured reading. The basic equation with a sample calculation is as follows:

$$FS = RA + AF + CL - AG$$

Where FS = Field Strength	CL = Cable Attenuation Factor (Cable Loss)
RA = Reading Amplitude	AG = Amplifier Gain
AF = Antenna Factor	

For example

Frequency (MHz)	FS (dBµV/m)	RA (dBµV/m)	AF (dB)	CL (dB)	AG (dB)	Transd (dB)
150.00	40	58.1	12.2	1.6	31.90	-18.1

$$Transd = AF + CL - AG$$

**Test Configuration**

For the actual test configuration, please refer to the related Item –EUT Test Photos.

**Frequency range 9 KHz – 30MHz**

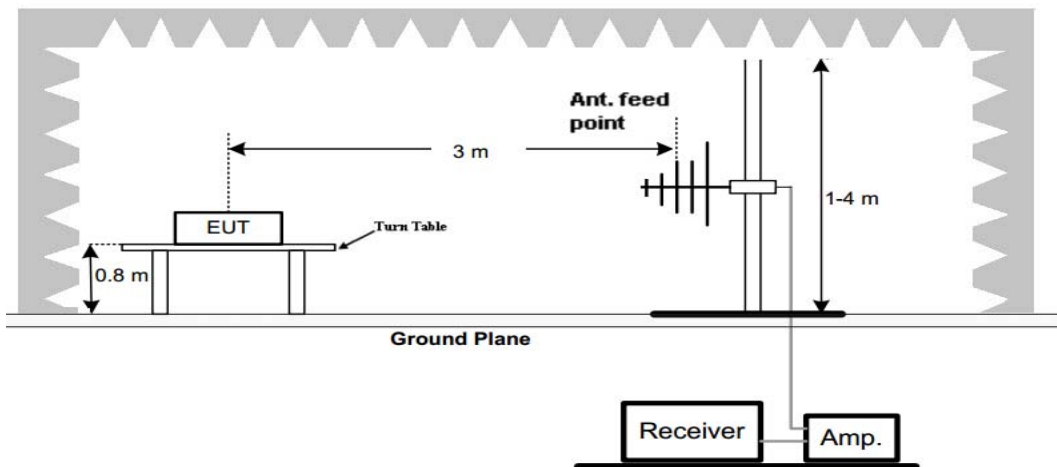
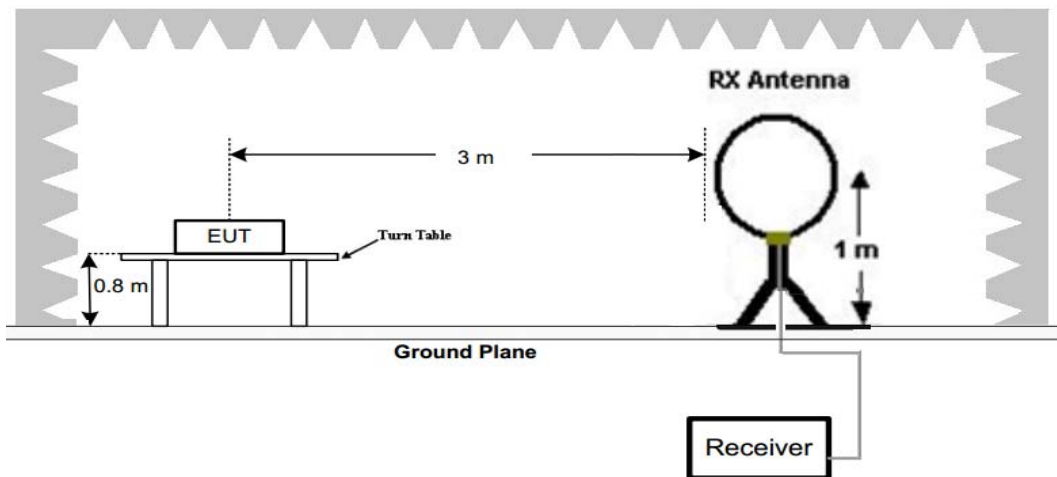

**Frequency range 30MHz – 1000MHz**

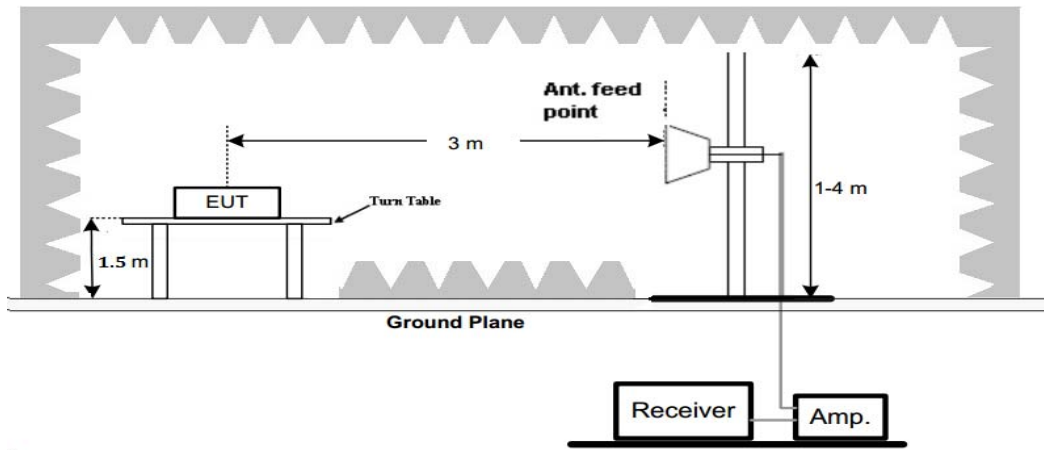

### Frequency range above 1GHz-25GHz

#### Test Results

##### Remark:

1. We measured Radiated Emission at GFSK,  $\pi/4$  DQPSK and 8DPSK mode from 9 KHz to 25GHz and recorded worst case at Low channel of GFSK mode below 1GHz.
2. By preliminary testing and verifying three axis (X, Y and Z) position of EUT transmitted status, it was found that "Z axis" position was the worst, and test data recorded in this report.



**For 9 KHz-30MHz**

Frequency (MHz)	Corrected Reading (dBuV/m)@3m	FCC Limit (dBuV/m) @3m	Margin (dB)	Detector	Result
0.14	53.54	104.68	51.14	QP	PASS
1.17	47.87	66.24	18.37	QP	PASS
14.37	34.01	69.54	35.53	QP	PASS
24.68	46.88	69.54	22.66	QP	PASS

**For 30MHz-1GHz**

**Horizontal**

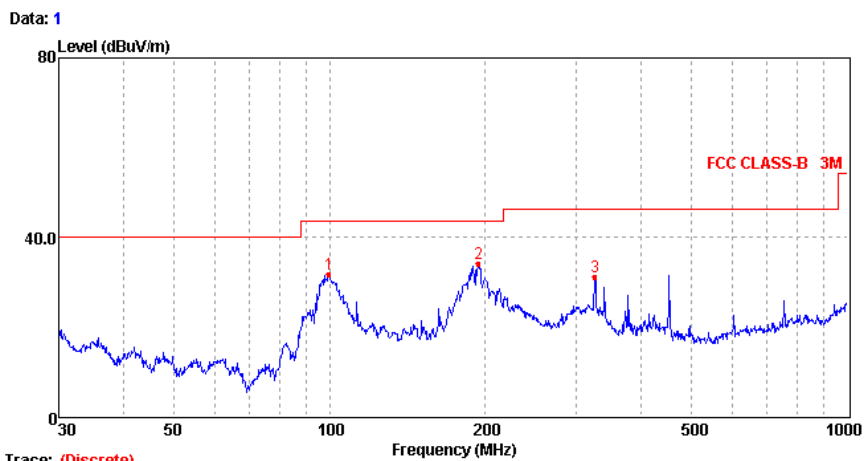

Mark	Frequency MHz	Level dBuV/m	Factor dB/m	Reading dBuV	Limit dBuV/m	Margin dB	Polarization	Detector
1	99.88	31.64	-19.39	51.03	43.50	11.86	HORIZONTAL	Peak
2	193.77	33.85	-18.45	52.30	43.50	9.65	HORIZONTAL	Peak
3	325.60	30.84	-16.24	47.08	46.00	15.16	HORIZONTAL	Peak

**Vertical**

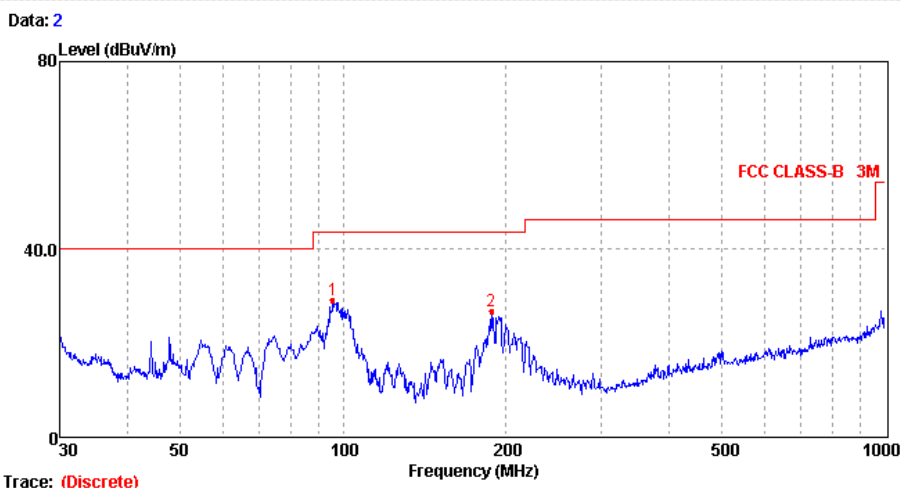

Mark	Frequency MHz	Level dBuV/m	Factor dB/m	Reading dBuV	Limit dBuV/m	Margin dB	Polarization	Detector
1	95.76	28.84	-19.72	48.56	43.50	14.66	VERTICAL	Peak
2	187.75	26.41	-19.03	45.44	43.50	17.09	VERTICAL	Peak

For 1GHz to 25GHz

**GFSK Mode (above 1GHz)**

Frequency(MHz):				2402			Polarity:			HORIZONTAL		
No.	Frequency (MHz)	Emission Level (dBuV/m)		Limit (dBuV/m)	Margin (dB)	Antenna Height (m)	Table Angle (Degree)	Raw Value (dBuV)	Antenna Factor (dB/m)	Cable Factor (dB)	Pre-amplifier (dB)	Correction Factor (dB/m)
1	4804.00	45.98	PK	74.00	28.02	1.00	142	44.08	31.42	6.98	36.5	1.90
1	4804.00	36.73	AV	54.00	17.27	1.00	142	34.83	31.42	6.98	36.5	1.90
2	7206.00	40.38	PK	74.00	33.62	1.00	142	29.78	37.03	8.87	35.3	10.60
2	7206.00	--	AV	--	--	--	--	--	--	--	--	--

Frequency(MHz):				2402			Polarity:			VERTICAL		
No.	Frequency (MHz)	Emission Level (dBuV/m)		Limit (dBuV/m)	Margin (dB)	Antenna Height (m)	Table Angle (Degree)	Raw Value (dBuV)	Antenna Factor (dB/m)	Cable Factor (dB)	Pre-amplifier (dB)	Correction Factor (dB/m)
1	4804.00	45.31	PK	74.00	28.69	1.00	79	43.41	31.42	6.98	36.5	1.90
1	4804.00	33.73	AV	54.00	20.27	1.00	79	31.83	31.42	6.98	36.5	1.90
2	7206.00	39.92	PK	74.00	34.08	1.00	79	29.32	37.03	8.87	35.3	10.60
2	7206.00	--	AV	--	--	--	--	--	--	--	--	--

Frequency(MHz):				2441			Polarity:			HORIZONTAL		
No.	Frequency (MHz)	Emission Level (dBuV/m)		Limit (dBuV/m)	Margin (dB)	Antenna Height (m)	Table Angle (Degree)	Raw Value (dBuV)	Antenna Factor (dB/m)	Cable Factor (dB)	Pre-amplifier (dB)	Correction Factor (dB/m)
1	4882.00	46.64	PK	74.00	27.36	1.00	128	44.58	30.98	7.58	36.5	2.06
1	4882.00	35.08	AV	54.00	18.92	1.00	128	33.02	30.98	7.58	36.5	2.06
2	7323.00	39.95	PK	74.00	34.05	1.00	128	29.03	37.66	8.56	35.3	10.92
2	7323.00	--	AV	--	--	--	--	--	--	--	--	--

Frequency(MHz):				2441			Polarity:			VERTICAL		
No.	Frequency (MHz)	Emission Level (dBuV/m)		Limit (dBuV/m)	Margin (dB)	Antenna Height (m)	Table Angle (Degree)	Raw Value (dBuV)	Antenna Factor (dB/m)	Cable Factor (dB)	Pre-amplifier (dB)	Correction Factor (dB/m)
1	4882.00	45.62	PK	74.00	28.38	1.00	85	43.56	30.98	7.58	36.5	2.06
1	4882.00	34.83	AV	54.00	19.17	1.00	85	32.77	30.98	7.58	36.5	2.06
2	7323.00	38.83	PK	74.00	35.17	1.00	85	27.91	37.66	8.56	35.3	10.92
2	7323.00	--	AV	--	--	--	--	--	--	--	--	--

Frequency(MHz):				2480			Polarity:			HORIZONTAL		
No.	Frequency (MHz)	Emission Level (dBuV/m)		Limit (dBuV/m)	Margin (dB)	Antenna Height (m)	Table Angle (Degree)	Raw Value (dBuV)	Antenna Factor (dB/m)	Cable Factor (dB)	Pre-amplifier (dB)	Correction Factor (dB/m)
1	4960.00	44.89	PK	74.00	29.11	1.00	113	41.82	31.47	7.80	36.2	3.07
1	4960.00	34.70	AV	54.00	19.30	1.00	113	31.63	31.47	7.80	36.2	3.07
2	7340.00	37.39	PK	74.00	36.61	1.00	113	25.65	38.32	8.72	35.3	11.74
2	7340.00	--	AV	--	--	--	--	--	--	--	--	--

Frequency(MHz):				2480			Polarity:			VERTICAL		
No.	Frequency (MHz)	Emission Level (dBuV/m)		Limit (dBuV/m)	Margin (dB)	Antenna Height (m)	Table Angle (Degree)	Raw Value (dBuV)	Antenna Factor (dB/m)	Cable Factor (dB)	Pre-amplifier (dB)	Correction Factor (dB/m)
1	4960.00	43.16	PK	74.00	30.84	1.00	74	40.09	31.47	7.80	36.2	3.07
1	4960.00	33.82	AV	54.00	20.18	1.00	74	30.75	31.47	7.80	36.2	3.07
2	7340.00	38.98	PK	74.00	35.02	1.00	74	27.24	38.32	8.72	35.3	11.74
2	7340.00	--	AV	--	--	--	--	--	--	--	--	--



REMARKS:

1. Emission level (dBuV/m) =Raw Value (dBuV)+Correction Factor (dB/m)
2. Correction Factor (dB/m) = Antenna Factor (dB/m)+Cable Factor (dB)-Pre-amplifier Factor
3. Margin value = Limit value- Emission level.
4. -- Mean the PK detector measured value is below average limit.
5. The other emission levels were very low against the limit.

**$\pi/4$ DQPSK Mode (above 1GHz)**

Frequency(MHz):				2402			Polarity:			HORIZONTAL		
No.	Frequency (MHz)	Emission Level (dBuV/m)		Limit (dBuV/m)	Margin (dB)	Antenna Height (m)	Table Angle (Degree)	Raw Value (dBuV)	Antenna Factor (dB/m)	Cable Factor (dB)	Pre-amplifier (dB)	Correction Factor (dB/m)
1	4804.00	46.11	PK	74.00	27.89	1.00	161	44.21	31.42	6.98	36.5	1.90
1	4804.00	36.00	AV	54.00	18.00	1.00	161	34.10	31.42	6.98	36.5	1.90
2	7206.00	39.13	PK	74.00	34.87	1.00	161	28.53	37.03	8.87	35.3	10.60
2	7206.00	--	AV	--	--	--	--	--	--	--	--	--

Frequency(MHz):				2402			Polarity:			VERTICAL		
No.	Frequency (MHz)	Emission Level (dBuV/m)		Limit (dBuV/m)	Margin (dB)	Antenna Height (m)	Table Angle (Degree)	Raw Value (dBuV)	Antenna Factor (dB/m)	Cable Factor (dB)	Pre-amplifier (dB)	Correction Factor (dB/m)
1	4804.00	45.39	PK	74.00	28.61	1.00	95	43.49	45.39	6.98	36.5	1.90
1	4804.00	33.15	AV	54.00	20.85	1.00	95	31.25	33.15	6.98	36.5	1.90
2	7206.00	39.06	PK	74.00	34.94	1.00	95	28.46	39.06	8.87	35.3	10.60
2	7206.00	--	AV	--	--	--	--	--	--	--	--	--

Frequency(MHz):				2441			Polarity:			HORIZONTAL		
No.	Frequency (MHz)	Emission Level (dBuV/m)		Limit (dBuV/m)	Margin (dB)	Antenna Height (m)	Table Angle (Degree)	Raw Value (dBuV)	Antenna Factor (dB/m)	Cable Factor (dB)	Pre-amplifier (dB)	Correction Factor (dB/m)
1	4882.00	46.82	PK	74.00	27.18	1.00	147	44.76	30.98	7.58	36.5	2.06
1	4882.00	35.70	AV	54.00	18.30	1.00	147	33.64	30.98	7.58	36.5	2.06
2	7323.00	39.36	PK	74.00	34.64	1.00	147	28.44	37.66	8.56	35.3	10.92
2	7323.00	--	AV	--	--	--	--	--	--	--	--	--

Frequency(MHz):				2441			Polarity:			VERTICAL		
No.	Frequency (MHz)	Emission Level (dBuV/m)		Limit (dBuV/m)	Margin (dB)	Antenna Height (m)	Table Angle (Degree)	Raw Value (dBuV)	Antenna Factor (dB/m)	Cable Factor (dB)	Pre-amplifier (dB)	Correction Factor (dB/m)
1	4882.00	47.02	PK	74.00	26.98	1.00	101	44.96	30.98	7.58	36.5	2.06
1	4882.00	36.11	AV	54.00	17.89	1.00	101	34.05	30.98	7.58	36.5	2.06
2	7323.00	39.59	PK	74.00	34.41	1.00	101	28.67	37.66	8.56	35.3	10.92
2	7323.00	--	AV	--	--	--	--	--	--	--	--	--

Frequency(MHz):				2480			Polarity:			HORIZONTAL		
No.	Frequency (MHz)	Emission Level (dBuV/m)		Limit (dBuV/m)	Margin (dB)	Antenna Height (m)	Table Angle (Degree)	Raw Value (dBuV)	Antenna Factor (dB/m)	Cable Factor (dB)	Pre-amplifier (dB)	Correction Factor (dB/m)
1	4960.00	45.13	PK	74.00	28.87	1.00	132	42.06	31.47	7.80	36.2	3.07
1	4960.00	34.06	AV	54.00	19.94	1.00	132	30.99	31.47	7.80	36.2	3.07
2	7340.00	36.60	PK	74.00	37.40	1.00	132	24.86	38.32	8.72	35.3	11.74
2	7340.00	--	AV	--	--	--	--	--	--	--	--	--

Frequency(MHz):				2480			Polarity:			VERTICAL		
No.	Frequency (MHz)	Emission Level (dBuV/m)		Limit (dBuV/m)	Margin (dB)	Antenna Height (m)	Table Angle (Degree)	Raw Value (dBuV)	Antenna Factor (dB/m)	Cable Factor (dB)	Pre-amplifier (dB)	Correction Factor (dB/m)
1	4960.00	43.46	PK	74.00	30.54	1.00	90	40.39	43.46	7.80	36.2	3.07
1	4960.00	35.99	AV	54.00	18.01	1.00	90	32.92	35.99	7.80	36.2	3.07
2	7340.00	39.17	PK	74.00	34.83	1.00	90	27.43	39.17	8.72	35.3	11.74
2	7340.00	--	AV	--	--	--	--	--	--	--	--	--



REMARKS:

6. Emission level (dBuV/m) =Raw Value (dBuV)+Correction Factor (dB/m)
7. Correction Factor (dB/m) = Antenna Factor (dB/m)+Cable Factor (dB)-Pre-amplifier Factor
8. Margin value = Limit value- Emission level.
9. -- Mean the PK detector measured value is below average limit.
10. The other emission levels were very low against the limit.

**8DPSK Mode (above 1GHz)**

Frequency(MHz):				2402			Polarity:			HORIZONTAL		
No.	Frequency (MHz)	Emission Level (dBuV/m)		Limit (dBuV/m)	Margin (dB)	Antenna Height (m)	Table Angle (Degree)	Raw Value (dBuV)	Antenna Factor (dB/m)	Cable Factor (dB)	Pre-amplifier (dB)	Correction Factor (dB/m)
1	4804.00	46.08	PK	74.00	27.92	1.00	172	44.18	31.42	6.98	36.5	1.90
1	4804.00	36.20	AV	54.00	17.80	1.00	172	34.30	31.42	6.98	36.5	1.90
2	7206.00	39.61	PK	74.00	34.39	1.00	172	29.01	37.03	8.87	35.3	10.60
2	7206.00	--	AV	--	--	--	--	--	--	--	--	--

Frequency(MHz):				2402			Polarity:			VERTICAL		
No.	Frequency (MHz)	Emission Level (dBuV/m)		Limit (dBuV/m)	Margin (dB)	Antenna Height (m)	Table Angle (Degree)	Raw Value (dBuV)	Antenna Factor (dB/m)	Cable Factor (dB)	Pre-amplifier (dB)	Correction Factor (dB/m)
1	4804.00	44.80	PK	74.00	29.20	1.00	83	42.90	31.42	6.98	36.5	1.90
1	4804.00	34.17	AV	54.00	19.83	1.00	83	32.27	31.42	6.98	36.5	1.90
2	7206.00	40.15	PK	74.00	33.85	1.00	83	29.55	37.03	8.87	35.3	10.60
2	7206.00	--	AV	--	--	--	--	--	--	--	--	--

Frequency(MHz):				2441			Polarity:			HORIZONTAL		
No.	Frequency (MHz)	Emission Level (dBuV/m)		Limit (dBuV/m)	Margin (dB)	Antenna Height (m)	Table Angle (Degree)	Raw Value (dBuV)	Antenna Factor (dB/m)	Cable Factor (dB)	Pre-amplifier (dB)	Correction Factor (dB/m)
1	4882.00	46.71	PK	74.00	27.29	1.00	158	44.65	30.98	7.58	36.5	2.06
1	4882.00	36.08	AV	54.00	17.92	1.00	158	34.02	30.98	7.58	36.5	2.06
2	7323.00	38.76	PK	74.00	35.24	1.00	158	27.84	37.66	8.56	35.3	10.92
2	7323.00	--	AV	--	--	--	--	--	--	--	--	--

Frequency(MHz):				2441			Polarity:			VERTICAL		
No.	Frequency (MHz)	Emission Level (dBuV/m)		Limit (dBuV/m)	Margin (dB)	Antenna Height (m)	Table Angle (Degree)	Raw Value (dBuV)	Antenna Factor (dB/m)	Cable Factor (dB)	Pre-amplifier (dB)	Correction Factor (dB/m)
1	4882.00	44.77	PK	74.00	29.23	1.00	89	42.71	30.98	7.58	36.5	2.06
1	4882.00	35.14	AV	54.00	18.86	1.00	89	33.08	30.98	7.58	36.5	2.06
2	7323.00	38.86	PK	74.00	35.14	1.00	89	27.94	37.66	8.56	35.3	10.92
2	7323.00	--	AV	--	--	--	--	--	--	--	--	--

Frequency(MHz):				2480			Polarity:			HORIZONTAL		
No.	Frequency (MHz)	Emission Level (dBuV/m)		Limit (dBuV/m)	Margin (dB)	Antenna Height (m)	Table Angle (Degree)	Raw Value (dBuV)	Antenna Factor (dB/m)	Cable Factor (dB)	Pre-amplifier (dB)	Correction Factor (dB/m)
1	4960.00	45.02	PK	74.00	28.98	1.00	143	41.95	31.47	7.80	36.2	3.07
1	4960.00	34.37	AV	54.00	19.63	1.00	143	31.30	31.47	7.80	36.2	3.07
2	7340.00	37.75	PK	74.00	36.25	1.00	143	26.01	38.32	8.72	35.3	11.74
2	7340.00	--	AV	--	--	--	--	--	--	--	--	--

Frequency(MHz):				2480			Polarity:			VERTICAL		
No.	Frequency (MHz)	Emission Level (dBuV/m)		Limit (dBuV/m)	Margin (dB)	Antenna Height (m)	Table Angle (Degree)	Raw Value (dBuV)	Antenna Factor (dB/m)	Cable Factor (dB)	Pre-amplifier (dB)	Correction Factor (dB/m)
1	4960.00	44.51	PK	74.00	29.49	1.00	78	41.44	31.47	7.80	36.2	3.07
1	4960.00	34.33	AV	54.00	19.67	1.00	78	31.26	31.47	7.80	36.2	3.07
2	7340.00	39.05	PK	74.00	34.95	1.00	78	27.31	38.32	8.72	35.3	11.74
2	7340.00	--	AV	--	--	--	--	--	--	--	--	--

REMARKS:

1. Emission level (dBUV/m) = Raw Value (dBUV) + Correction Factor (dB/m)
2. Correction Factor (dB/m) = Antenna Factor (dB/m) + Cable Factor (dB) - Pre-amplifier Factor
3. Margin value = Limit value - Emission level.
4. -- Mean the PK detector measured value is below average limit.
5. The other emission levels were very low against the limit.

### 3.3. Maximum Peak Output Power

#### Limit

The Maximum Peak Output Power Measurement is 30dBm.

#### Test Procedure

Remove the antenna from the EUT and then connect a low loss RF cable from the antenna port to the spectrum. Set the spectrum RBW: 3MHz; VBW: 10MHz; Detector: Peak; Span: 10MHz.

#### Test Configuration

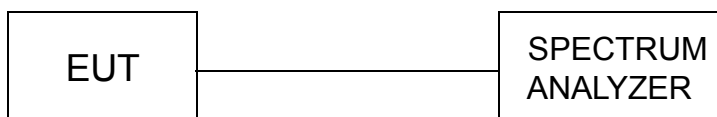

#### Test Results

Type	Channel	Output power (dBm)	Limit (dBm)	Result
GFSK	00	0.99	30.00	Pass
	39	1.61		
	78	2.60		
π/4DQPSK	00	1.90	21.00	Pass
	39	2.50		
	78	3.34		
8DPSK	00	1.81	21.00	Pass
	39	2.39		
	78	3.27		

Note: 1.The test results including the cable lose.

Test plot as follows:





$\pi/4$ DQPSK Modulation

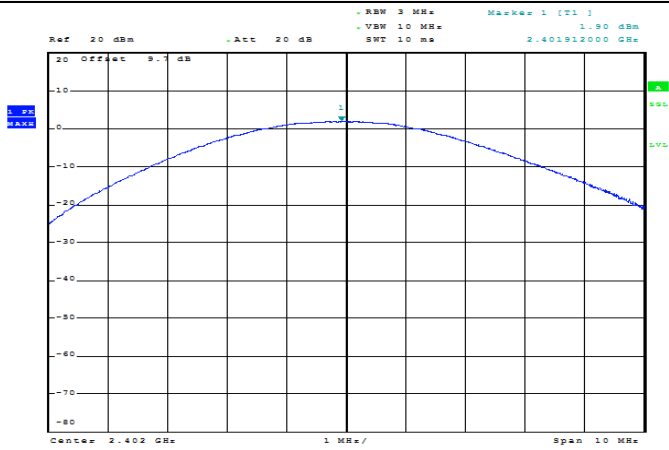

CH00

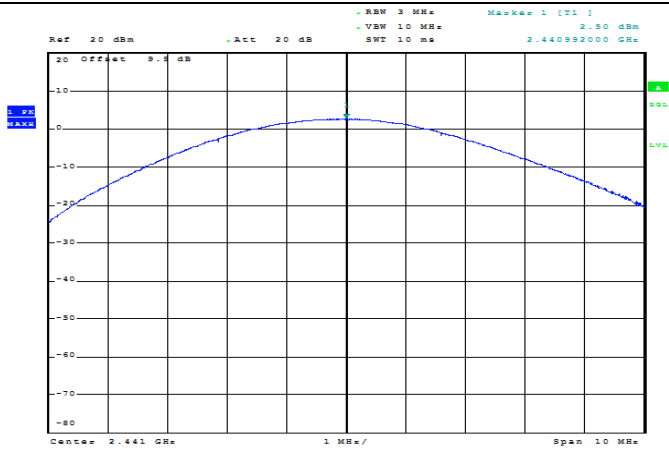

CH39

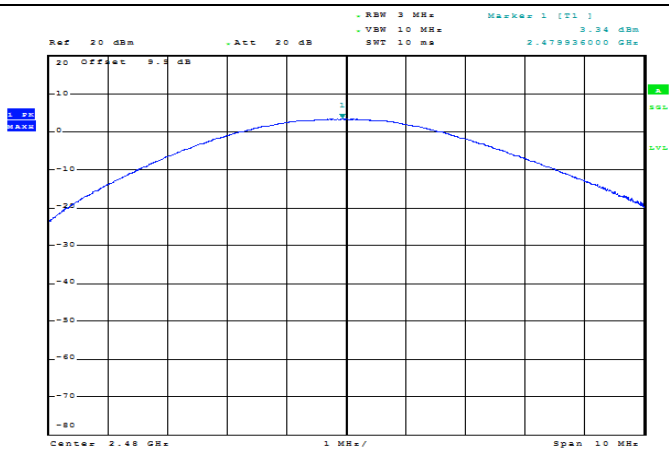

CH78



### 3.4. 20dB Bandwidth

#### Limit

For frequency hopping systems operating in the 2400MHz-2483.5MHz no limit for 20dB bandwidth.

#### Test Procedure

The transmitter output was connected to the spectrum analyzer through a low loss RF cable. The bandwidth of the fundamental frequency was measured by spectrum analyzer with 30 KHz RBW and 100 KHz VBW.

The 20dB bandwidth is defined as the total spectrum the power of which is higher than peak power minus 20dB.

#### Test Configuration

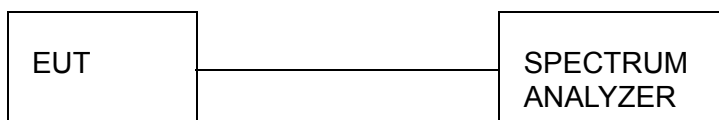

#### Test Results

Modulation	Channel	20dB bandwidth (MHz)	99% OBW(MHz)	Result
GFSK	CH00	0.962	0.889	Pass
	CH39	0.957	0.885	
	CH78	0.962	0.865	
π/4DQPSK	CH00	1.394	1.317	
	CH39	1.394	1.317	
	CH78	1.399	1.317	
8DPSK	CH00	1.389	1.317	
	CH39	1.389	1.317	
	CH78	1.394	1.317	

Test plot as follows:

### GFSK Modulation

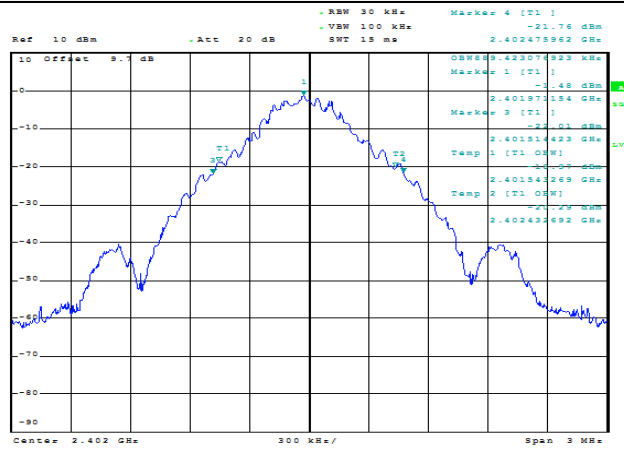

### CH00

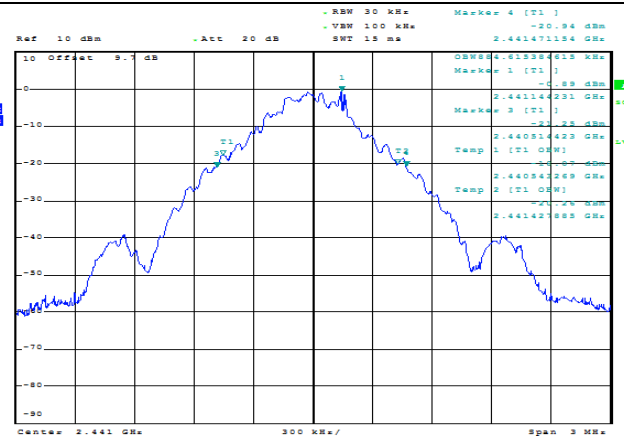

### CH39

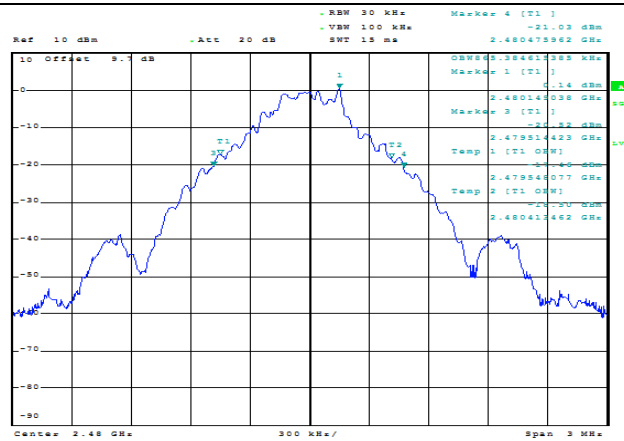

### CH78

$\pi/4$ DQPSK Modulation

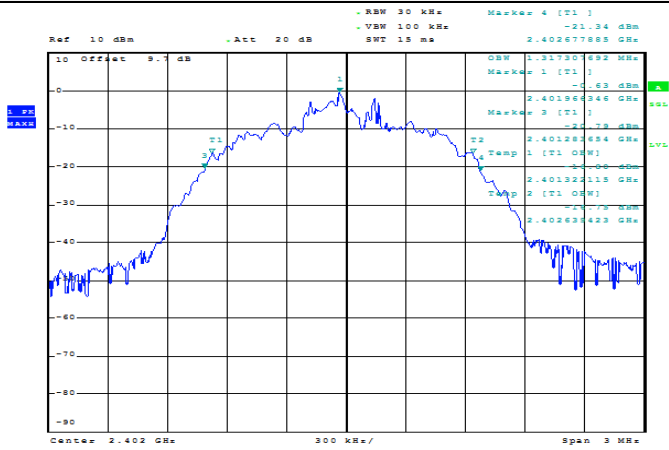

CH00

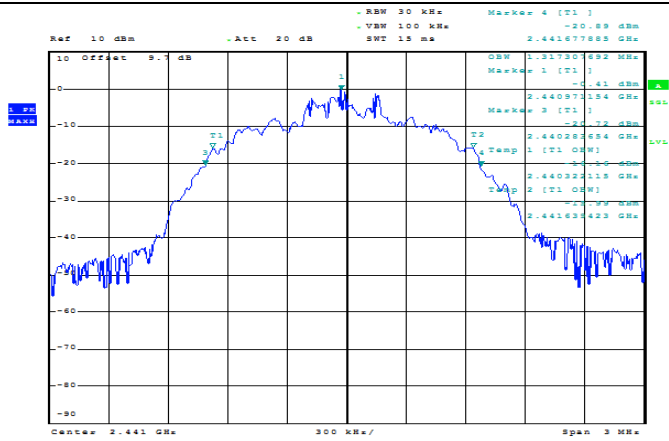

CH39

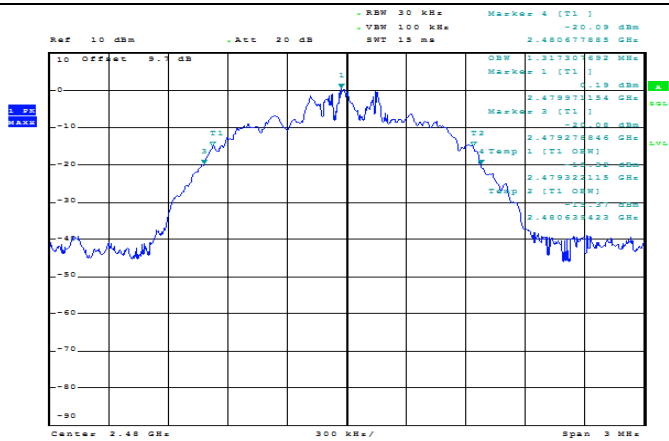

CH78

### 8DPSK Modulation

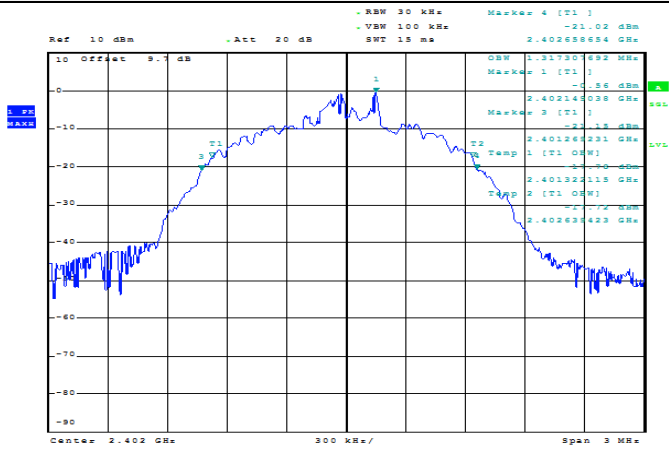

### CH00

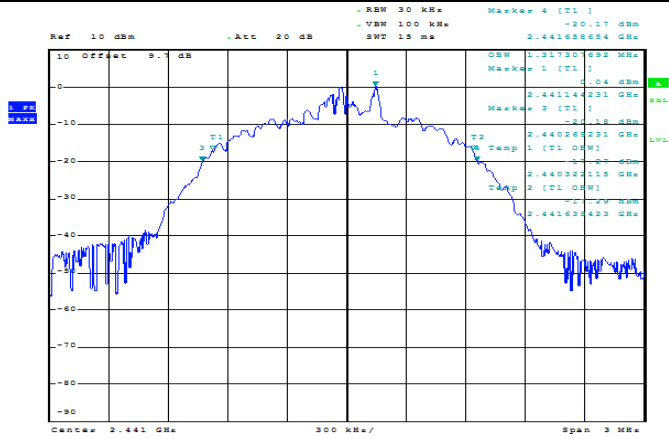

### CH39

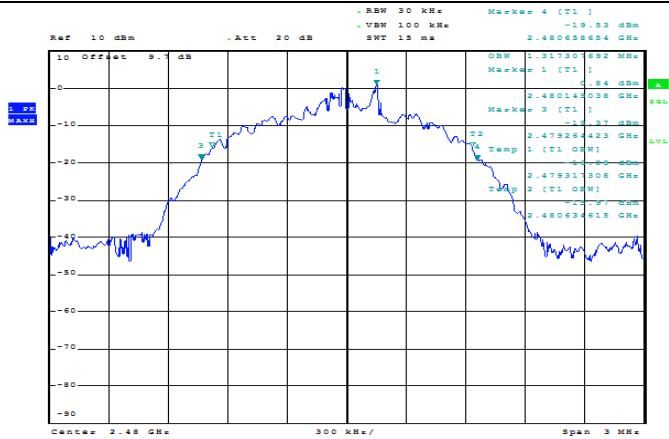

### CH78

### 3.5. Band Edge

#### **Applicable Standard**

In any 100 kHz bandwidth outside the frequency band in which the spread spectrum or digitally modulated intentional radiator is operating, the radio frequency power that is produced by the intentional radiator shall be at least 20 dB below that in the 100 kHz bandwidth within the band that contains the highest level of the desired power, based on either an RF conducted or a radiated measurement, provided the transmitter demonstrates compliance with the peak conducted power limits. If the transmitter complies with the conducted power limits based on the use of RMS averaging over a time interval, as permitted under paragraph (b)(3) of this section, the attenuation required under this paragraph shall be 30 dB instead of 20 dB. Attenuation below the general limits specified in §15.209(a) is not required. In addition, radiated emissions which fall in the restricted bands, as defined in §15.205(a), must also comply with the radiated emission limits specified in §15.209(a) (see §15.205(c)).

#### **Test Procedure**

##### **Test Procedure for conducted method**

1. Remove the antenna from the EUT and then connect to a low loss RF cable from the antenna port to a spectrum analyzer
2. Turn on the EUT and make it operate in transmitting mode. Then set it to Low Channel and High Channel within its operating range, and make sure the instrument is operated in its linear range.
3. Set spectrum analyzer RBW =100 kHz and VBW=300 kHz
4. Use spectrum analyzer Maxhold function to allow trace to fully stabilize
5. Marker the highest point which fall into restricted frequency bands
6. Repeat above procedures until all measured frequencies were complete.

##### **Test Procedure for radiated method**

1. The EUT was placed on the top of a rotating table 0.8 meters above the ground at a 3 meter anechoic chamber. The table was rotated 360 degrees to determine the position of the highest radiation.
2. The EUT was set 3 meters away from the interference receiving antenna, which was mounted on the top of a variable height antenna tower.
3. The antenna height is varied from one meter to four meters above the ground to determine the maximum value of the field strength. Both horizontal and vertical polarizations of the antenna are set to make the measurement.
4. For each suspected emission, the EUT was arranged to its worst case and then the antenna was tuned to heights from 1 meter to 4 meters and the rotatable table was turned from 0 degrees to 360 degrees to find the maximum reading.
5. The test-receiver system was set to Peak Detect Function and Specified Bandwidth with Maximum Hold Mode.
6. Place a marker at the end of the restricted band closest to the transmit frequency to show compliance. Also measure any emissions in the restricted bands. Save the spectrum analyzer plot. Repeat for each power and modulation for lowest and highest channel
7. Test the EUT in the lowest channel, the highest channel
8. The radiation measurements are performed in X, Y, Z axis positioning. And found the X axis positioning which it is worse case, only the test worst case mode is recorded in the report.
9. Repeat above procedures until all frequencies measured was complete.

#### **TEST RESULTS**

Remark: we measured all conditions (DH1, DH3, DH5) and recorded worst case at DH5



**A. Conducted Bandedge Measurement**

**GFSK**

Frequency (MHz)	Delta Peak to Band emission (dBc)	Hopping Mode	Limit (dBc)	Verdict
2376.056	53.484	OFF	20	PASS
2381.936	51.216	ON	20	PASS
2486.528	45.771	OFF	20	PASS
2483.500	49.384	ON	20	PASS

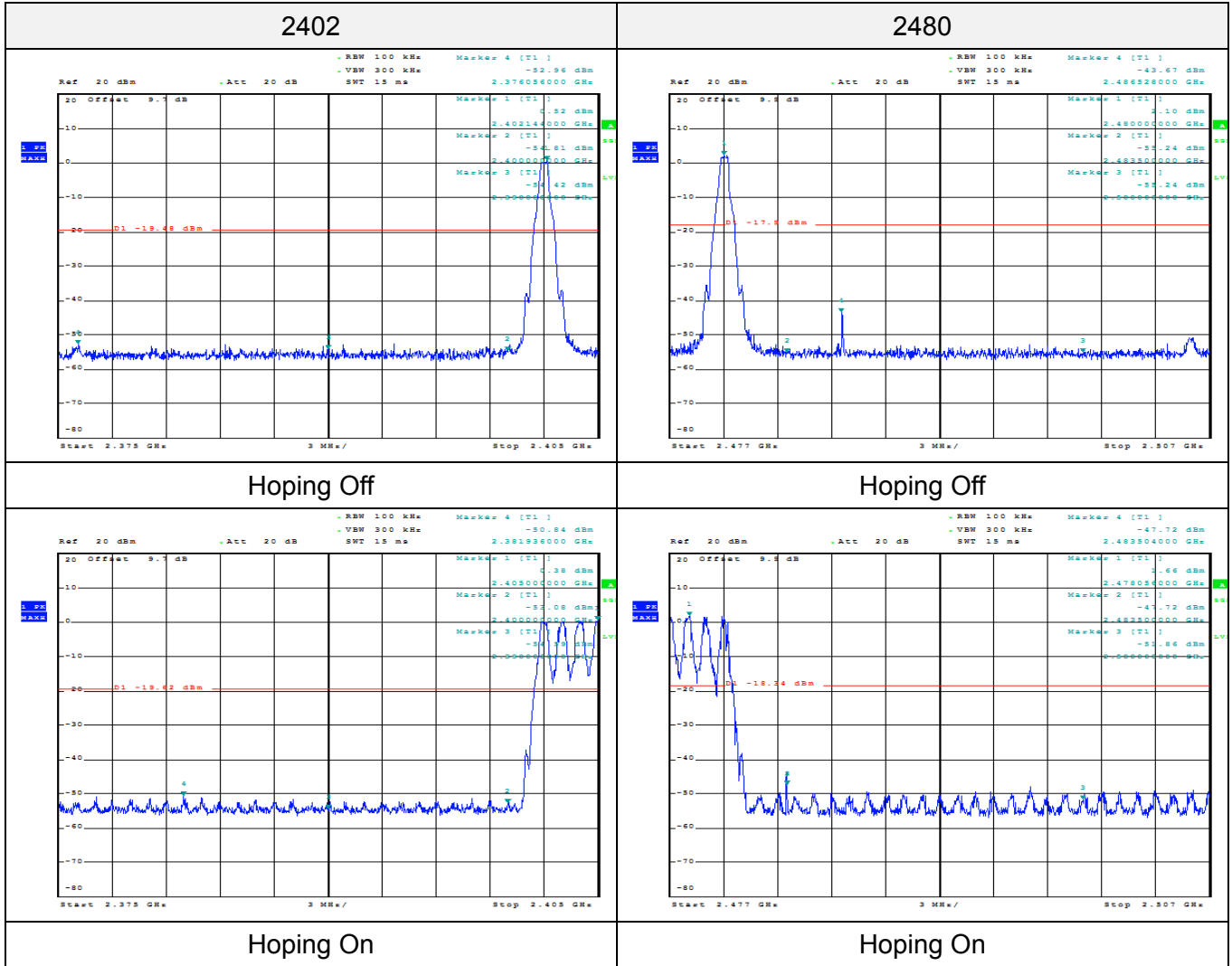

$\pi/4$ DQPSK

Frequency (MHz)	Delta Peak to Band emission (dBc)	Hopping Mode	Limit (dBc)	Verdict
2387.144	54.107	OFF	20	PASS
2385.056	54.972	ON	20	PASS
2486.576	50.879	OFF	20	PASS
2486.528	47.197	ON	20	PASS

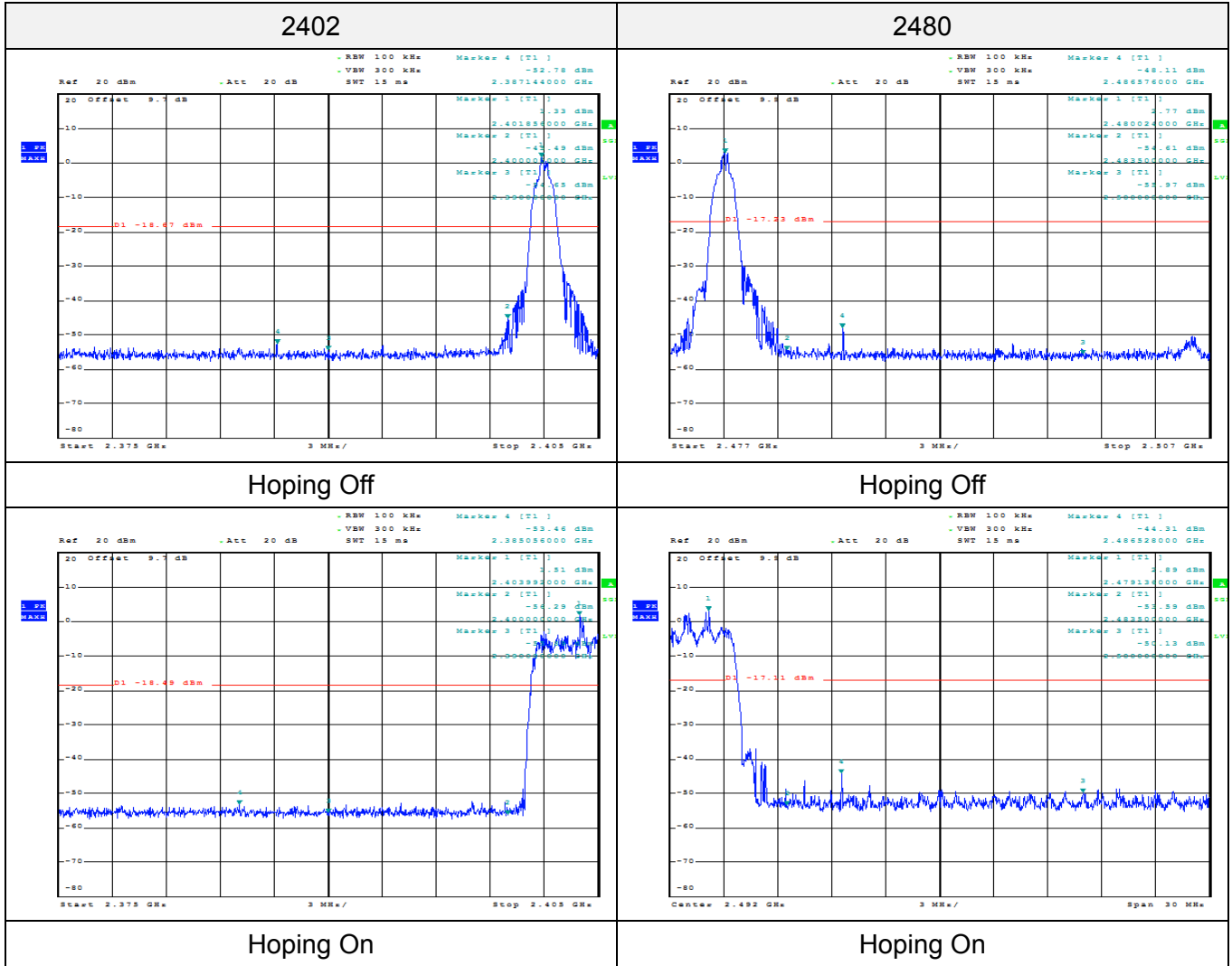

8DPSK

Frequency (MHz)	Delta Peak to Band emission (dBc)	Hopping Mode	Limit (dBc)	Verdict
2378.936	54.265	OFF	20	PASS
2388.128	53.426	ON	20	PASS
2486.432	47.983	OFF	20	PASS
2495.144	49.794	ON	20	PASS

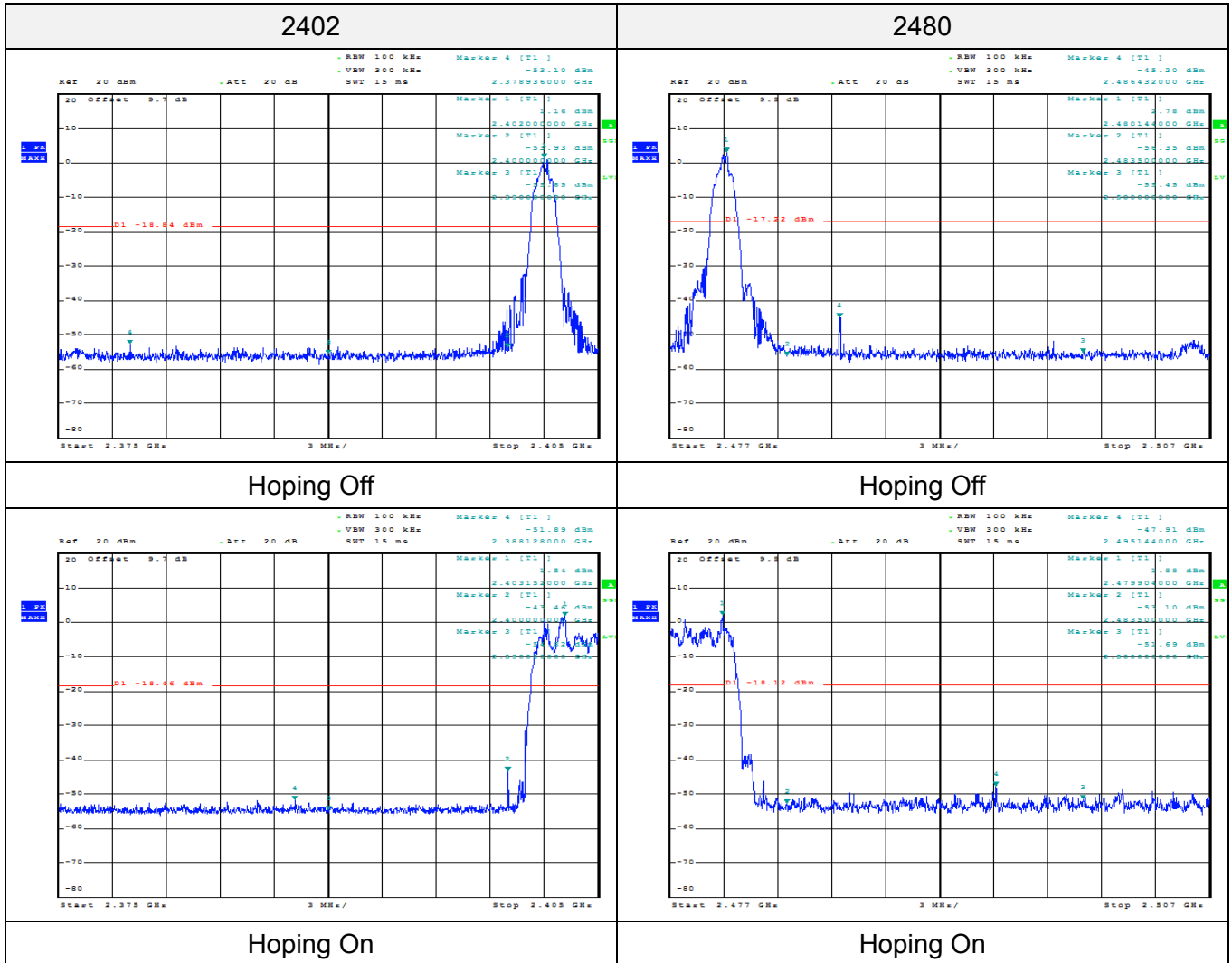

**B. Radiated measurements**

Remark: we tested hopping mode and Hopping off mode, the worse case is hopping off mode represented this report.

**GFSK**

Frequency(MHz):			2402			Polarity:			HORIZONTAL		
Frequency (MHz)	Emission Level (dBuV/m)		Limit (dBuV/m)	Margin (dB)	Antenna Height (m)	Table Angle (Degree)	Raw Value (dBuV)	Antenna Factor (dB/m)	Cable Factor (dB)	Pre-amplifier (dB)	Correction Factor (dB/m)
2390.00	46.89	PK	74.00	27.11	1.00	45	52.20	27.49	3.32	36.12	-5.31
2390.00	34.06	AV	54.00	19.94	1.00	45	39.37	27.49	3.32	36.12	-5.31
Frequency(MHz):			2402			Polarity:			VERTICAL		
Frequency (MHz)	Emission Level (dBuV/m)		Limit (dBuV/m)	Margin (dB)	Antenna Height (m)	Table Angle (Degree)	Raw Value (dBuV)	Antenna Factor (dB/m)	Cable Factor (dB)	Pre-amplifier (dB)	Correction Factor (dB/m)
2390.00	47.08	PK	74.00	26.92	1.00	117	52.39	27.49	3.32	36.12	-5.31
2390.00	34.98	AV	54.00	19.02	1.00	117	40.29	27.49	3.32	36.12	-5.31
Frequency(MHz):			2480			Polarity:			HORIZONTAL		
Frequency (MHz)	Emission Level (dBuV/m)		Limit (dBuV/m)	Margin (dB)	Antenna Height (m)	Table Angle (Degree)	Raw Value (dBuV)	Antenna Factor (dB/m)	Cable Factor (dB)	Pre-amplifier (dB)	Correction Factor (dB/m)
2483.50	45.45	PK	74.00	28.55	1.00	23	51.17	27.45	3.38	36.55	-5.72
2483.50	33.20	AV	54.00	20.80	1.00	23	38.92	27.45	3.38	36.55	-5.72
Frequency(MHz):			2480			Polarity:			VERTICAL		
Frequency (MHz)	Emission Level (dBuV/m)		Limit (dBuV/m)	Margin (dB)	Antenna Height (m)	Table Angle (Degree)	Raw Value (dBuV)	Antenna Factor (dB/m)	Cable Factor (dB)	Pre-amplifier (dB)	Correction Factor (dB/m)
2483.50	45.24	PK	74.00	28.76	1.00	134	50.96	27.45	3.38	36.55	-5.72
2483.50	33.20	AV	54.00	20.80	1.00	134	38.92	27.45	3.38	36.55	-5.72

**$\pi/4$ QPSK**

Frequency(MHz):			2402			Polarity:			HORIZONTAL		
Frequency (MHz)	Emission Level (dBuV/m)		Limit (dBuV/m)	Margin (dB)	Antenna Height (m)	Table Angle (Degree)	Raw Value (dBuV)	Antenna Factor (dB/m)	Cable Factor (dB)	Pre-amplifier (dB)	Correction Factor (dB/m)
2390.00	47.14	PK	74.00	26.86	1.00	56	52.45	27.49	3.32	36.12	-5.31
2390.00	34.73	AV	54.00	19.27	1.00	56	40.04	27.49	3.32	36.12	-5.31
Frequency(MHz):			2402			Polarity:			VERTICAL		
Frequency (MHz)	Emission Level (dBuV/m)		Limit (dBuV/m)	Margin (dB)	Antenna Height (m)	Table Angle (Degree)	Raw Value (dBuV)	Antenna Factor (dB/m)	Cable Factor (dB)	Pre-amplifier (dB)	Correction Factor (dB/m)
2390.00	46.09	PK	74.00	27.91	1.00	100	51.40	27.49	3.32	36.12	-5.31
2390.00	35.38	AV	54.00	18.62	1.00	100	40.69	27.49	3.32	36.12	-5.31
Frequency(MHz):			2480			Polarity:			HORIZONTAL		
Frequency (MHz)	Emission Level (dBuV/m)		Limit (dBuV/m)	Margin (dB)	Antenna Height (m)	Table Angle (Degree)	Raw Value (dBuV)	Antenna Factor (dB/m)	Cable Factor (dB)	Pre-amplifier (dB)	Correction Factor (dB/m)
2483.50	46.31	PK	74.00	27.69	1.00	34	52.03	27.45	3.38	36.55	-5.72
2483.50	33.07	AV	54.00	20.93	1.00	34	38.79	27.45	3.38	36.55	-5.72
Frequency(MHz):			2480			Polarity:			VERTICAL		
Frequency (MHz)	Emission Level (dBuV/m)		Limit (dBuV/m)	Margin (dB)	Antenna Height (m)	Table Angle (Degree)	Raw Value (dBuV)	Antenna Factor (dB/m)	Cable Factor (dB)	Pre-amplifier (dB)	Correction Factor (dB/m)
2483.50	44.73	PK	74.00	29.27	1.00	117	50.45	27.45	3.38	36.55	-5.72
2483.50	35.27	AV	54.00	18.73	1.00	117	40.99	27.45	3.38	36.55	-5.72

**8DPSK**

Frequency(MHz):			2402			Polarity:			HORIZONTAL		
Frequency (MHz)	Emission Level (dBuV/m)		Limit (dBuV/m)	Margin (dB)	Antenna Height (m)	Table Angle (Degree)	Raw Value (dBuV)	Antenna Factor (dB/m)	Cable Factor (dB)	Pre-amplifier (dB)	Correction Factor (dB/m)
2390.00	47.27	PK	74.00	26.73	1.00	69	52.58	27.49	3.32	36.12	-5.31
2390.00	35.10	AV	54.00	18.90	1.00	69	40.41	27.49	3.32	36.12	-5.31
Frequency(MHz):			2402			Polarity:			VERTICAL		
Frequency (MHz)	Emission Level (dBuV/m)		Limit (dBuV/m)	Margin (dB)	Antenna Height (m)	Table Angle (Degree)	Raw Value (dBuV)	Antenna Factor (dB/m)	Cable Factor (dB)	Pre-amplifier (dB)	Correction Factor (dB/m)
2390.00	46.81	PK	74.00	27.19	1.00	147	52.12	27.49	3.32	36.12	-5.31
2390.00	35.21	AV	54.00	18.79	1.00	147	40.52	27.49	3.32	36.12	-5.31
Frequency(MHz):			2480			Polarity:			HORIZONTAL		
Frequency (MHz)	Emission Level (dBuV/m)		Limit (dBuV/m)	Margin (dB)	Antenna Height (m)	Table Angle (Degree)	Raw Value (dBuV)	Antenna Factor (dB/m)	Cable Factor (dB)	Pre-amplifier (dB)	Correction Factor (dB/m)
2483.50	46.47	PK	74.00	27.53	1.00	47	52.19	27.45	3.38	36.55	-5.72
2483.50	35.14	AV	54.00	18.86	1.00	47	40.86	27.45	3.38	36.55	-5.72
Frequency(MHz):			2480			Polarity:			VERTICAL		
Frequency (MHz)	Emission Level (dBuV/m)		Limit (dBuV/m)	Margin (dB)	Antenna Height (m)	Table Angle (Degree)	Raw Value (dBuV)	Antenna Factor (dB/m)	Cable Factor (dB)	Pre-amplifier (dB)	Correction Factor (dB/m)
2483.50	44.81	PK	74.00	29.19	1.00	164	50.53	27.45	3.38	36.55	-5.72
2483.50	34.82	AV	54.00	19.18	1.00	164	40.54	27.45	3.38	36.55	-5.72

### 3.6. Frequency Separation

#### LIMIT

According to 15.247(a)(1), frequency hopping systems shall have hopping channel carrier frequencies separated by minimum of 25KHz or the  $2/3 * 20\text{dB}$  bandwidth of the hopping channel, whichever is greater.

#### TEST PROCEDURE

The transmitter output was connected to the spectrum analyzer through a low loss RF cable. The bandwidth of the fundamental frequency was measured by spectrum analyzer with 30 KHz RBW and 100KHz VBW.

#### TEST CONFIGURATION

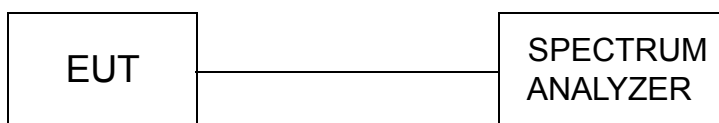

#### TEST RESULTS

Modulation	Channel	Channel Separation (MHz)	Limit(MHz)	Result
GFSK	CH39	1.000	25KHz or $2/3 * 20\text{dB}$ bandwidth	Pass
	CH40			
$\pi/4$ DQPSK	CH39	1.000	25KHz or $2/3 * 20\text{dB}$ bandwidth	Pass
	CH40			
8DPSK	CH39	1.000	25KHz or $2/3 * 20\text{dB}$ bandwidth	Pass
	CH40			

Note:

We have tested all mode at high, middle and low channel, and recorded worst case at middle

#### Test plot as follows:

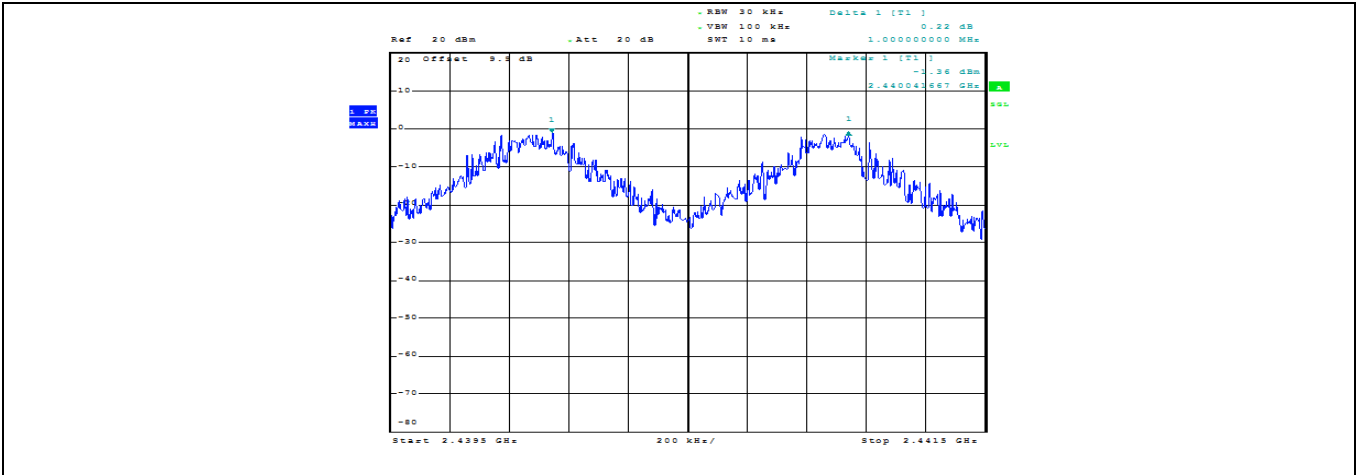

**GFSK**

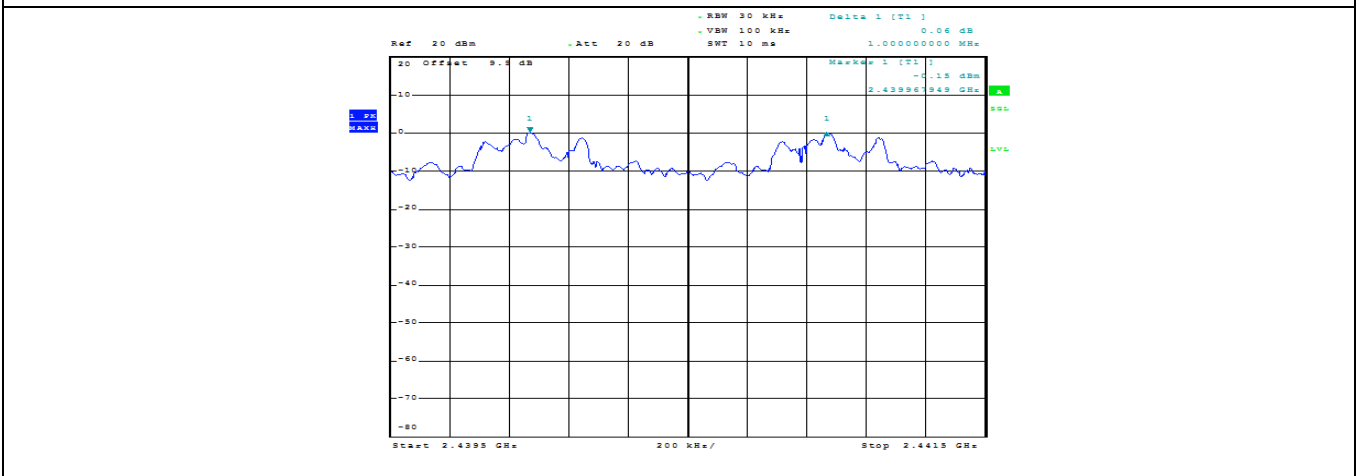

**$\pi/4$ DQPSK**

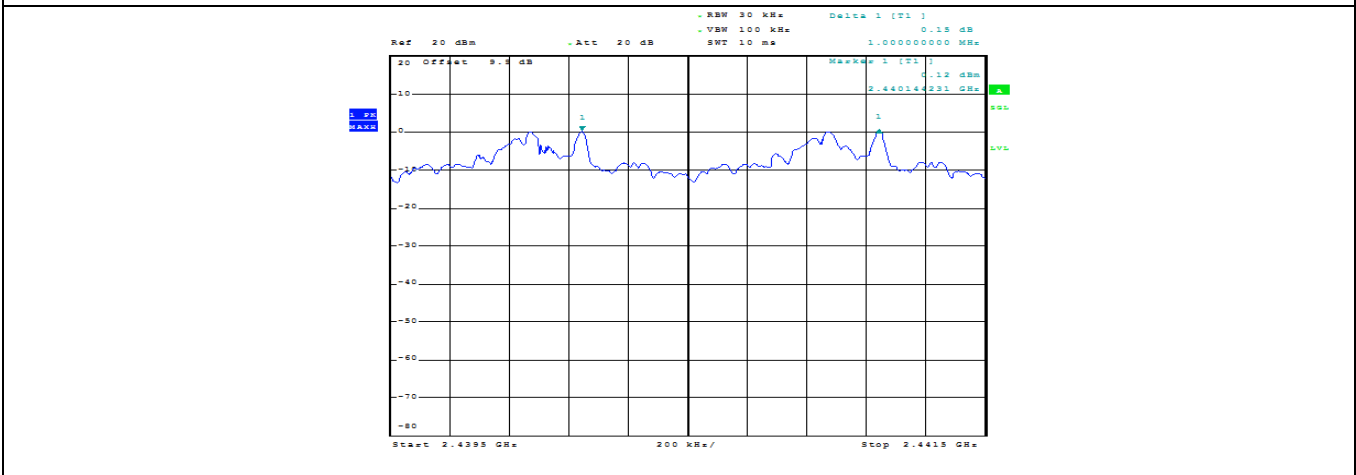

**8DPSK**

### 3.7. Number of hopping frequency

#### Limit

Frequency hopping systems in the 2400–2483.5 MHz band shall use at least 15 channels.

#### Test Procedure

The transmitter output was connected to the spectrum analyzer through a low loss RF cable. Set spectrum analyzer start 2400MHz to 2483.5MHz with 100 KHz RBW and 300 KHz VBW.

#### Test Configuration

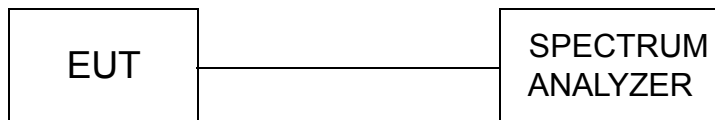

#### Test Results

Modulation	Number of Hopping Channel	Limit	Result
GFSK	79	≥15	Pass
$\pi/4$ DQPSK	79		
8DPSK	79		

#### Test plot as follows:



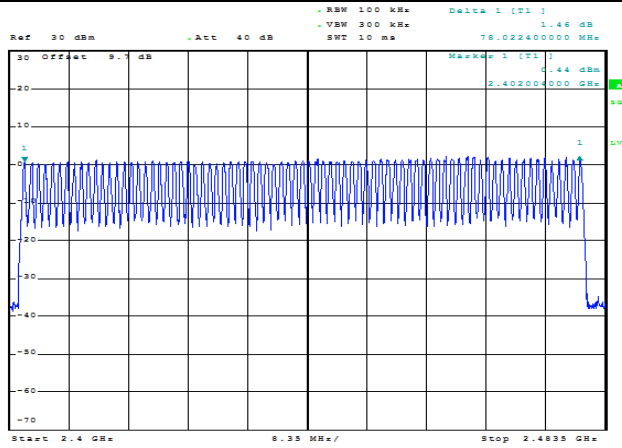

**GFSK Modulation**

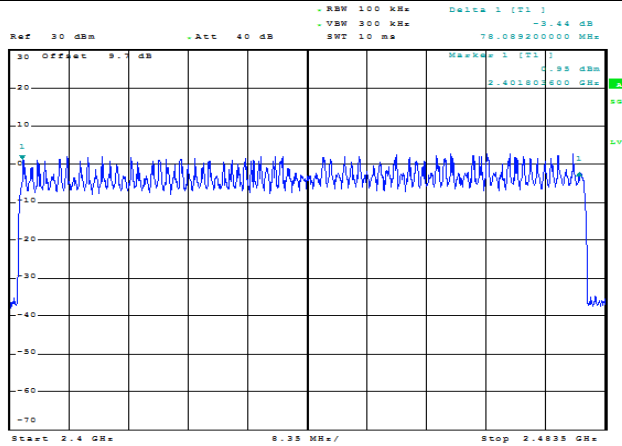

**$\pi/4$ DQPSK Modulation**

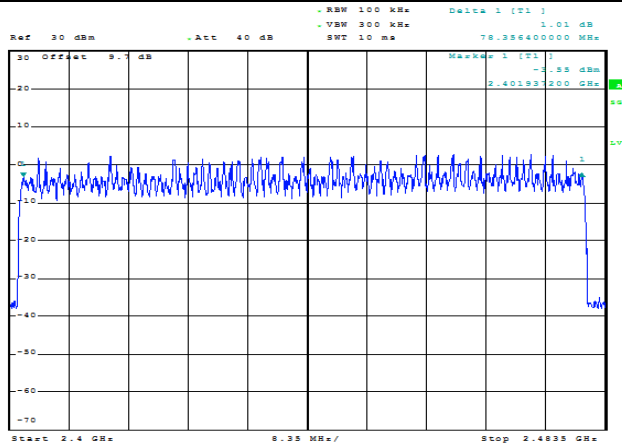

**8DPSK Modulation**

### 3.8. Time of Occupancy (Dwell Time)

#### Limit

The average time of occupancy on any channel shall not be greater than 0.4 seconds within a period of 0.4 seconds multiplied by the number of hopping channels employed.

#### Test Procedure

The transmitter output was connected to the spectrum analyzer through a low loss RF cable. Set center frequency of spectrum analyzer=operating frequency with 1MHz RBW and 3MHz VBW,Span 0Hz.

#### Test Configuration

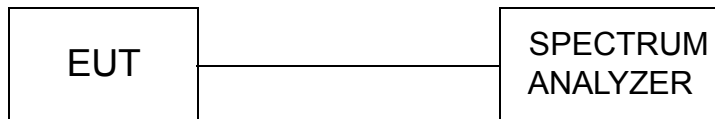

#### Test Results

Modulation	Packet	Dwell time (second)	Limit (second)	Result
GFSK	DH1	0.124	0.40	Pass
	DH3	0.264		
	DH5	0.099		
π/4DQPSK	2-DH1	0.128	0.40	Pass
	2-DH3	0.264		
	2-DH5	0.314		
8DPSK	3-DH1	0.130	0.40	Pass
	3-DH3	0.266		
	3-DH5	0.314		

Note:

- We have tested all mode at high,middle and low channel,and recoreded worst case at middle channel.
- $Dwell\ time = Pulse\ time\ (ms) \times (1600 \div 2 \div 79) \times 31.6\ Second$  for DH1, 2-DH1, 3-DH1  
 $Dwell\ time = Pulse\ time\ (ms) \times (1600 \div 4 \div 79) \times 31.6\ Second$  for DH3, 2-DH3, 3-DH3  
 $Dwell\ time = Pulse\ time\ (ms) \times (1600 \div 6 \div 79) \times 31.6\ Second$  for DH5, 2-DH5, 3-DH5

#### Test plot as follows:

### GFSK Modulation

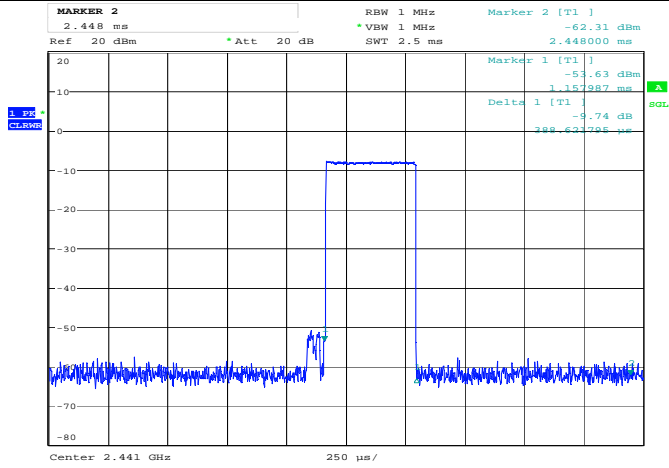

### DH1

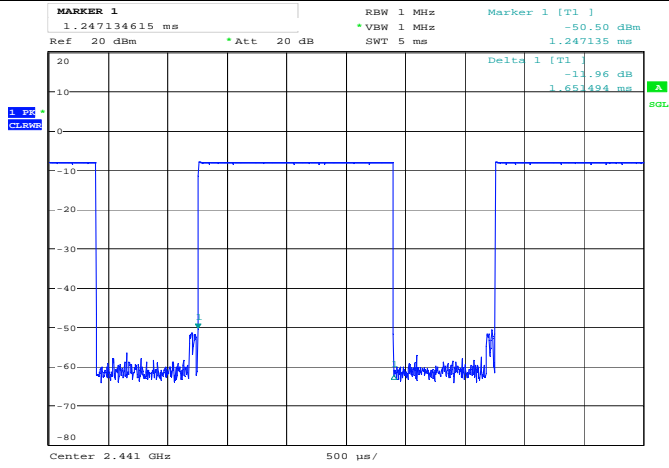

### DH3

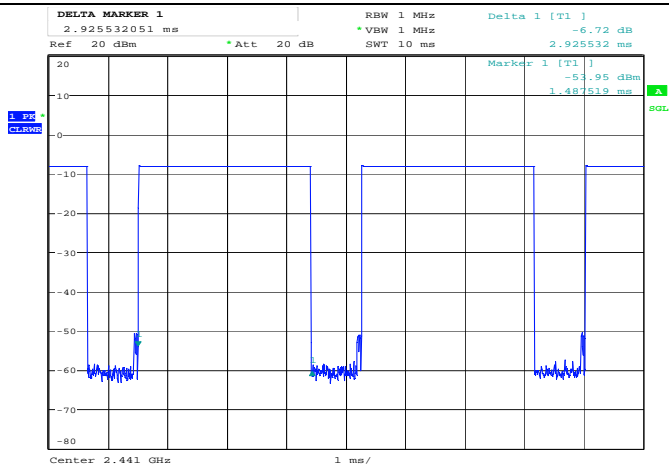

### DH5

### $\pi/4$ DQPSK Modulation

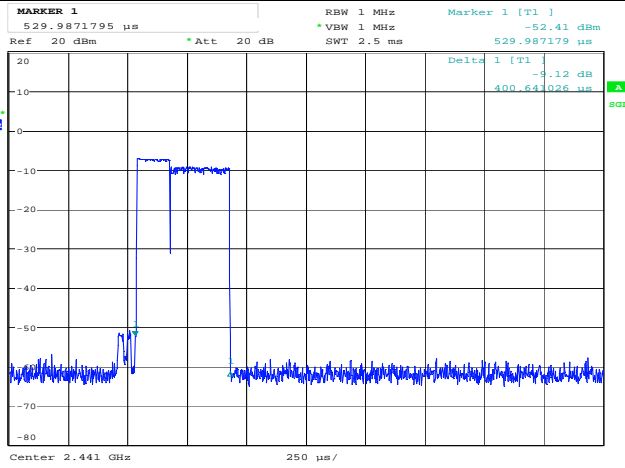

### 2DH1

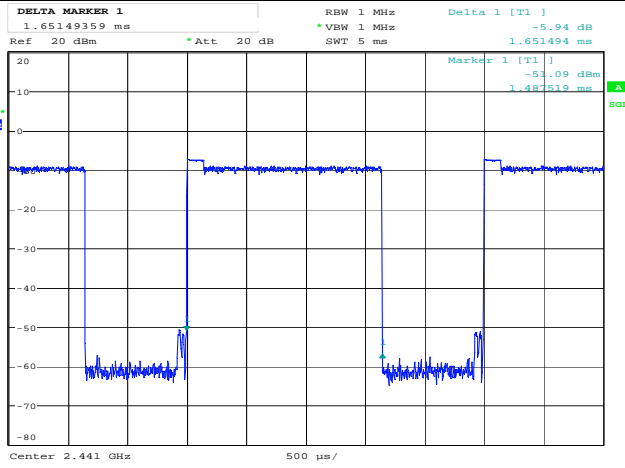

### 2DH3

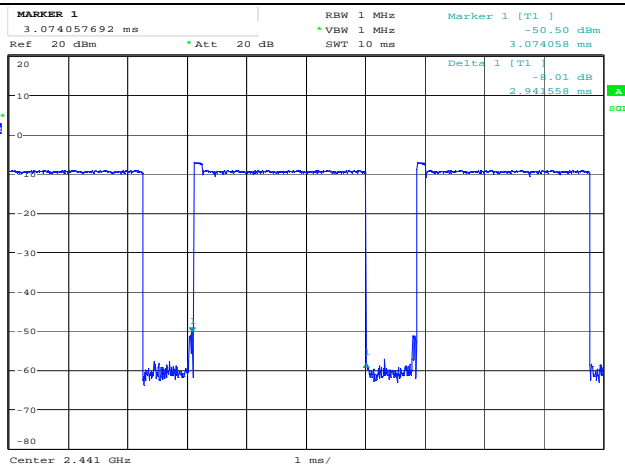

### 2DH5

### 8DPSK Modulation

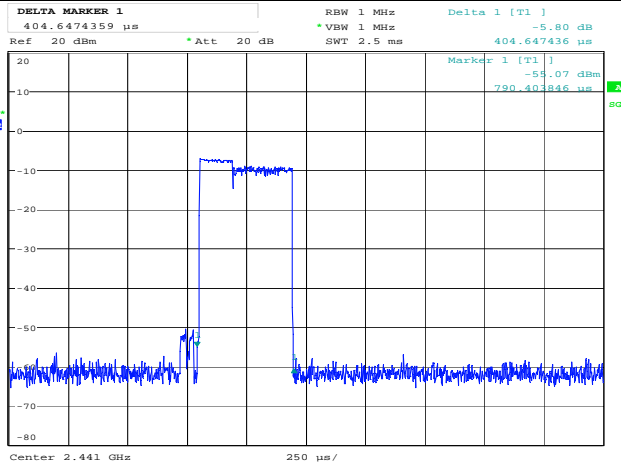

### 3DH1

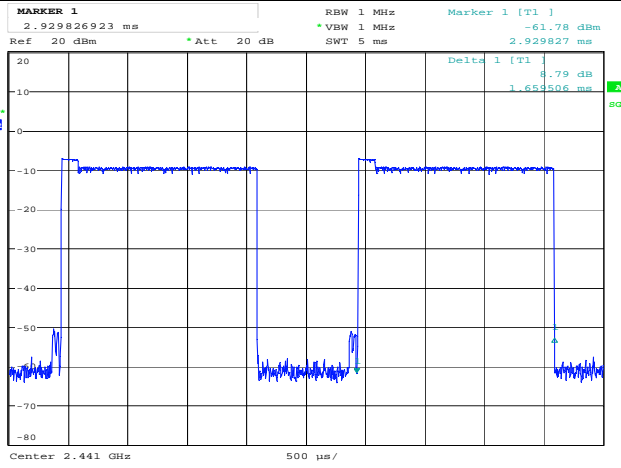

### 3DH3

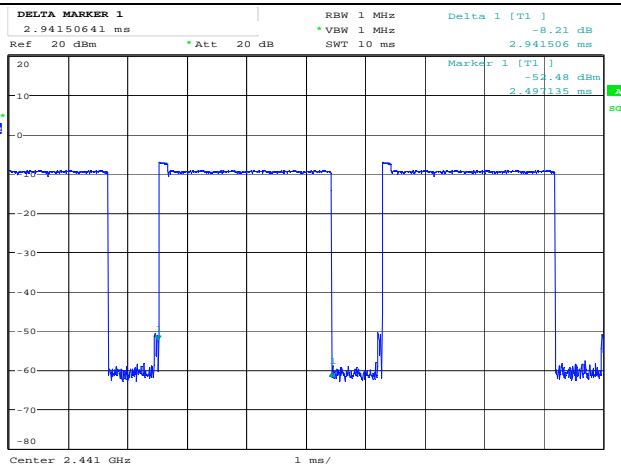

### 3DH5

### 3.9. Spurious RF Conducted Emission

#### Limit

1. Below -20dB of the highest emission level in operating band.
2. Fall in the restricted bands listed in section 15.205. The maximum permitted average field strength is listed in section 15.209.

#### Test Procedure

The transmitter output was connected to the spectrum analyzer through a low loss RF cable. Spurious RF Conducted Emission was measured by spectrum analyzer with 100 KHz RBW and 300KHz VBW, measurement frequency range from 30MHz to 26.5GHz.

#### Test Configuration

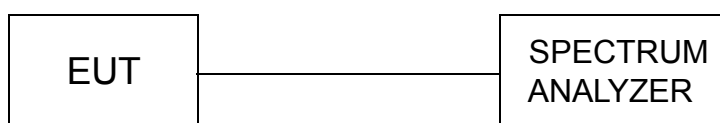

#### Test Results

Remark: The measurement frequency range is from 30MHz to the 10th harmonic of the fundamental frequency. The lowest, middle and highest channels are tested to verify the spurious emissions.

We measured all conditions (DH1, DH3, DH5, 2DH1, 2DH3, 2DH5, 3DH1, 3DH3, 3DH5,) and recorded worst case at DH5, 2DH5, 3DH5.

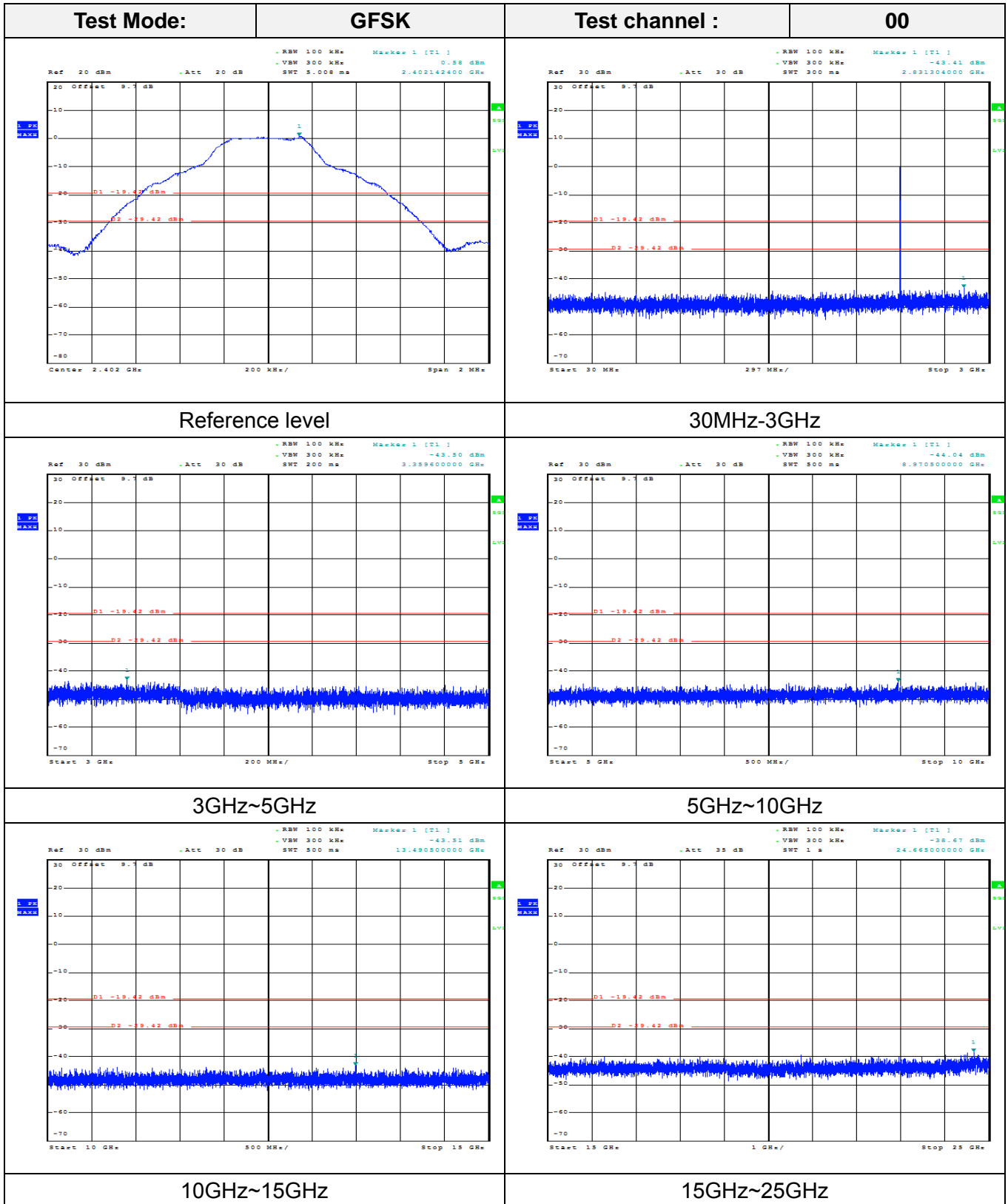

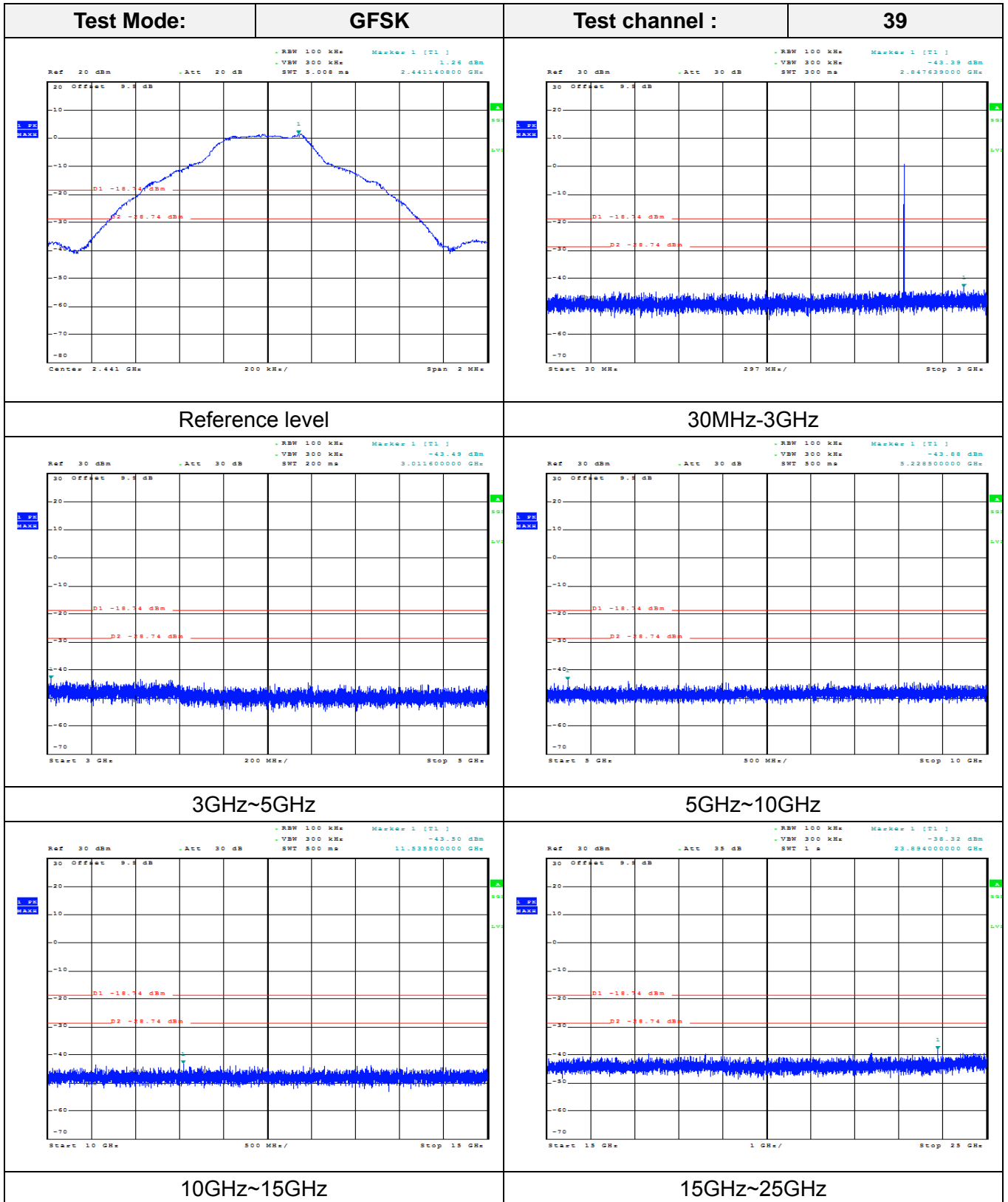



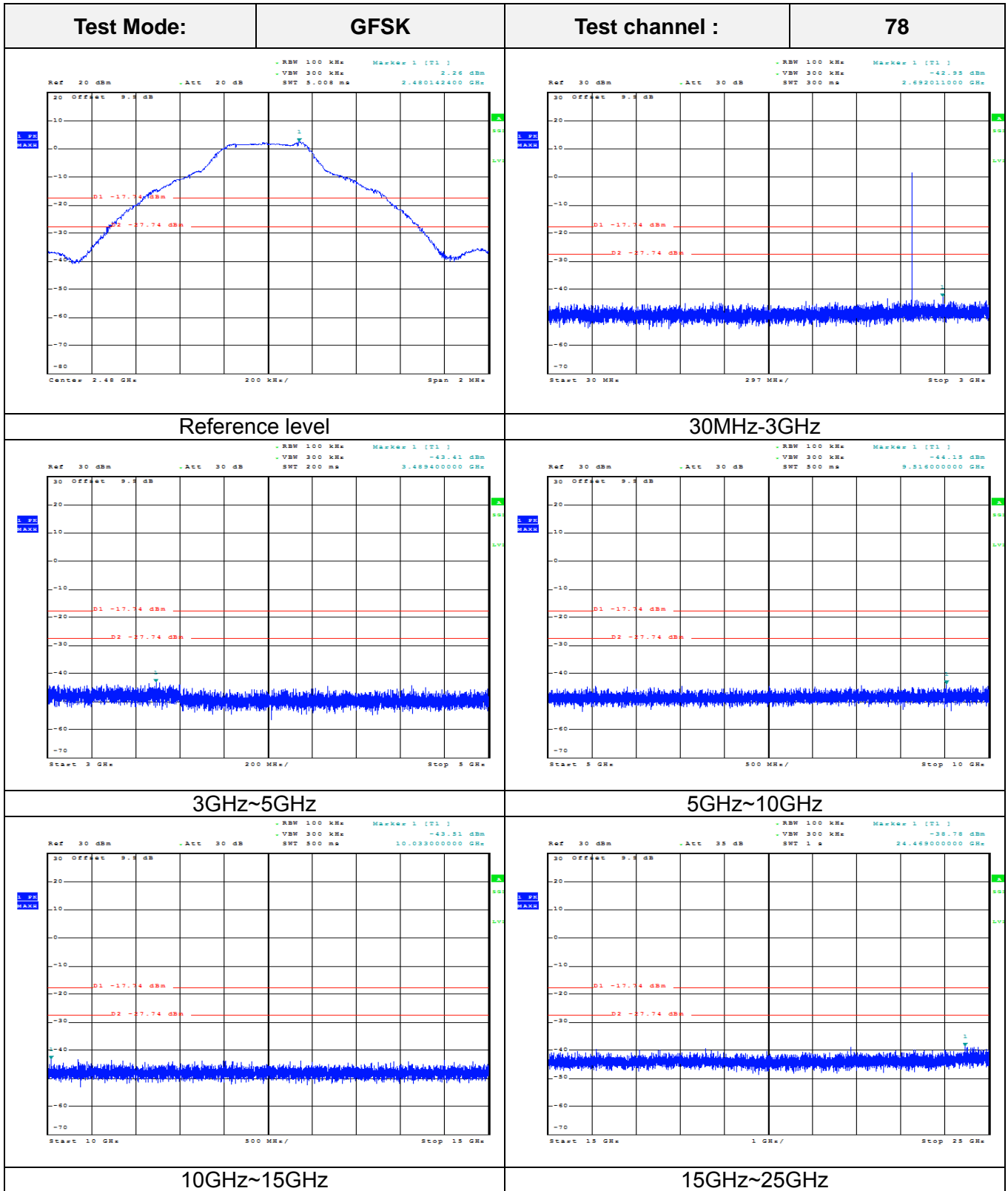

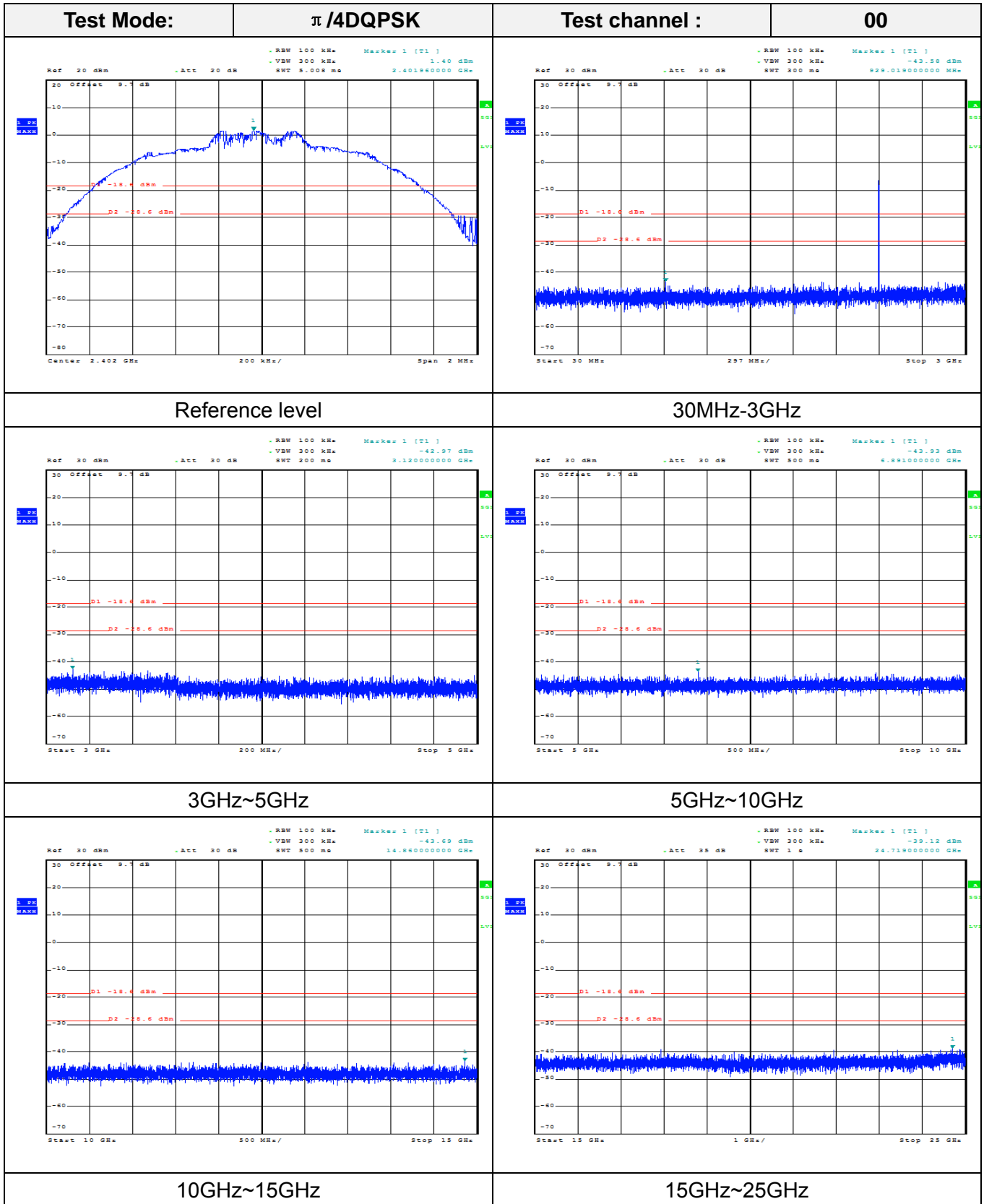

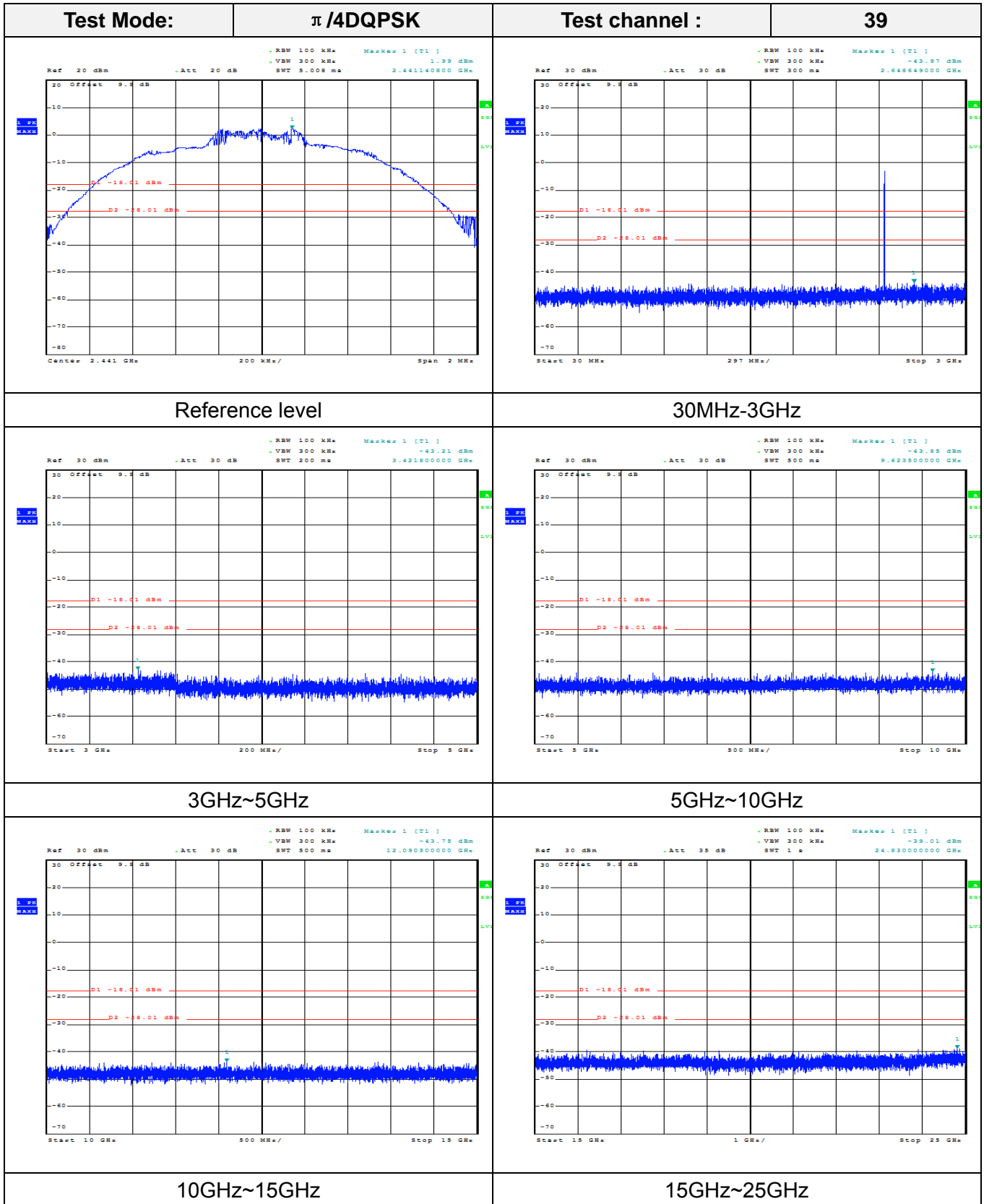

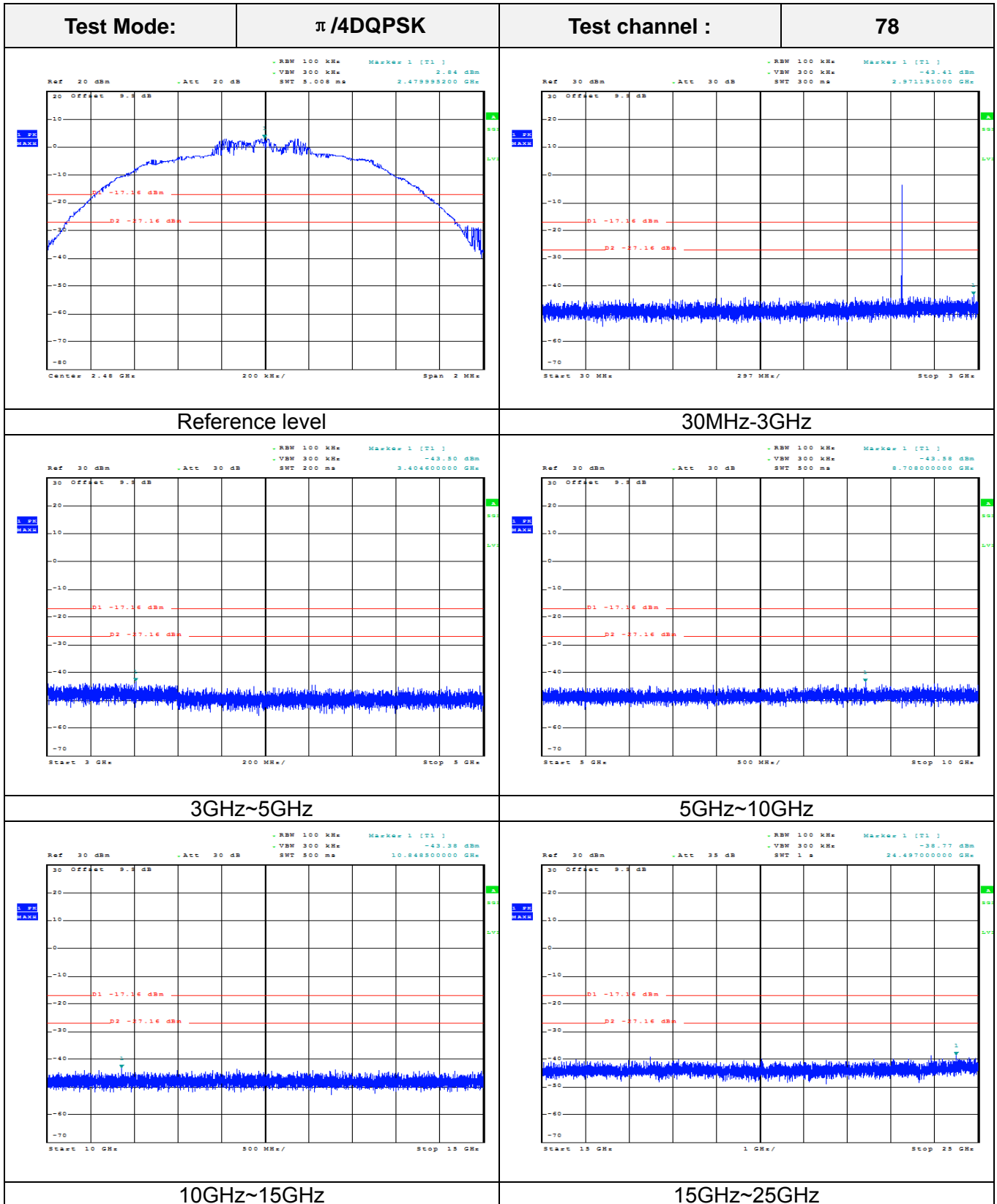

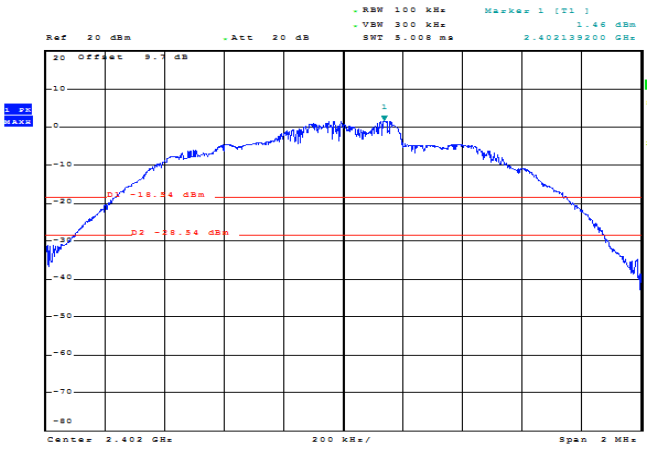
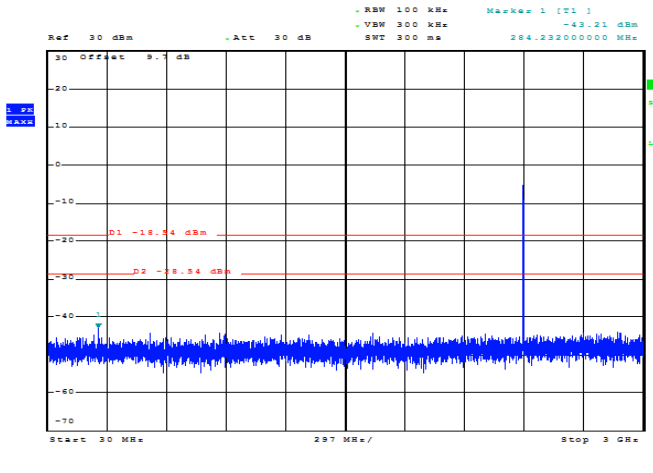
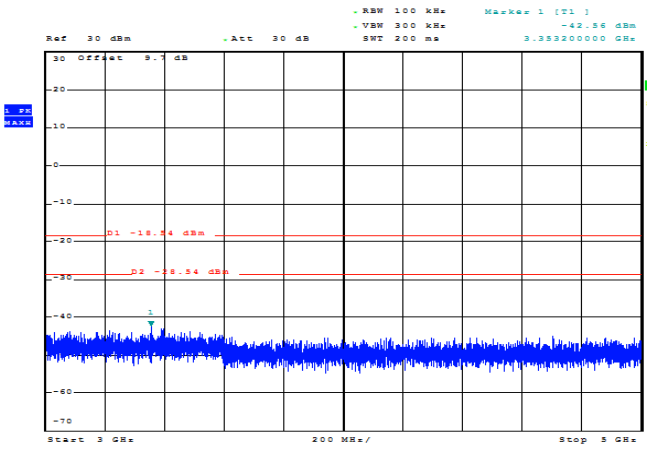
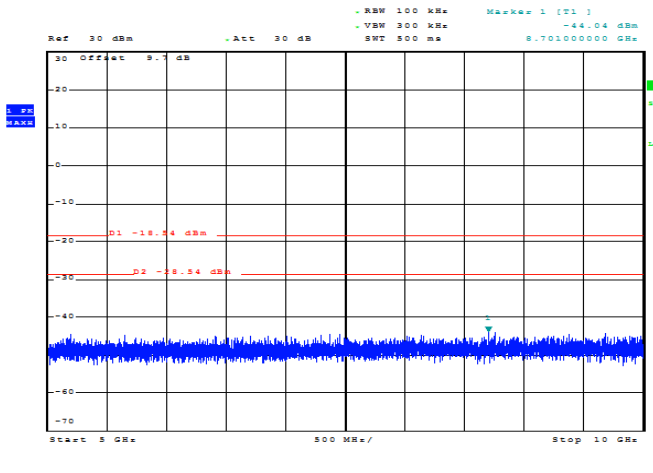
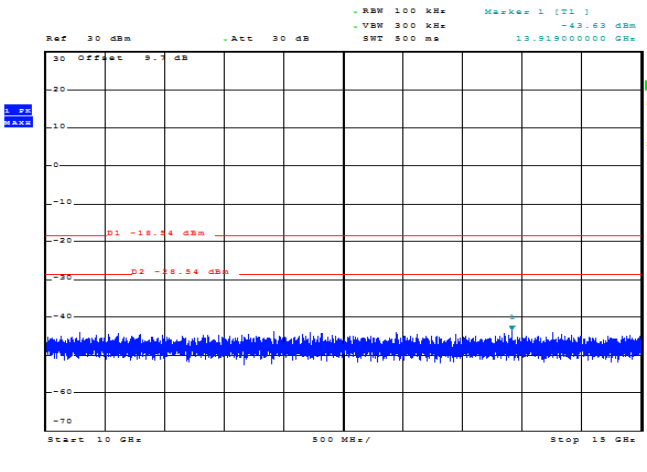
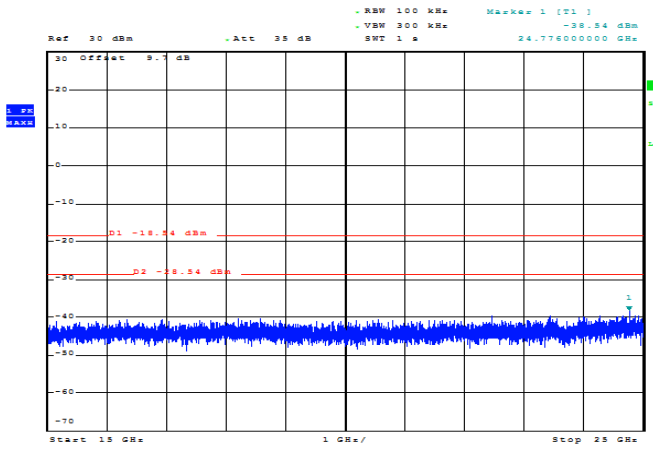
Test Mode:	8DPSK	Test channel :	00
			
Reference level		30MHz-3GHz	
			
3GHz~5GHz		5GHz~10GHz	
			
10GHz~15GHz		15GHz~25GHz	

Test Mode:	8DPSK	Test channel :	39
Reference level		30MHz-3GHz	
3GHz~5GHz		5GHz~10GHz	
10GHz~15GHz		15GHz~25GHz	

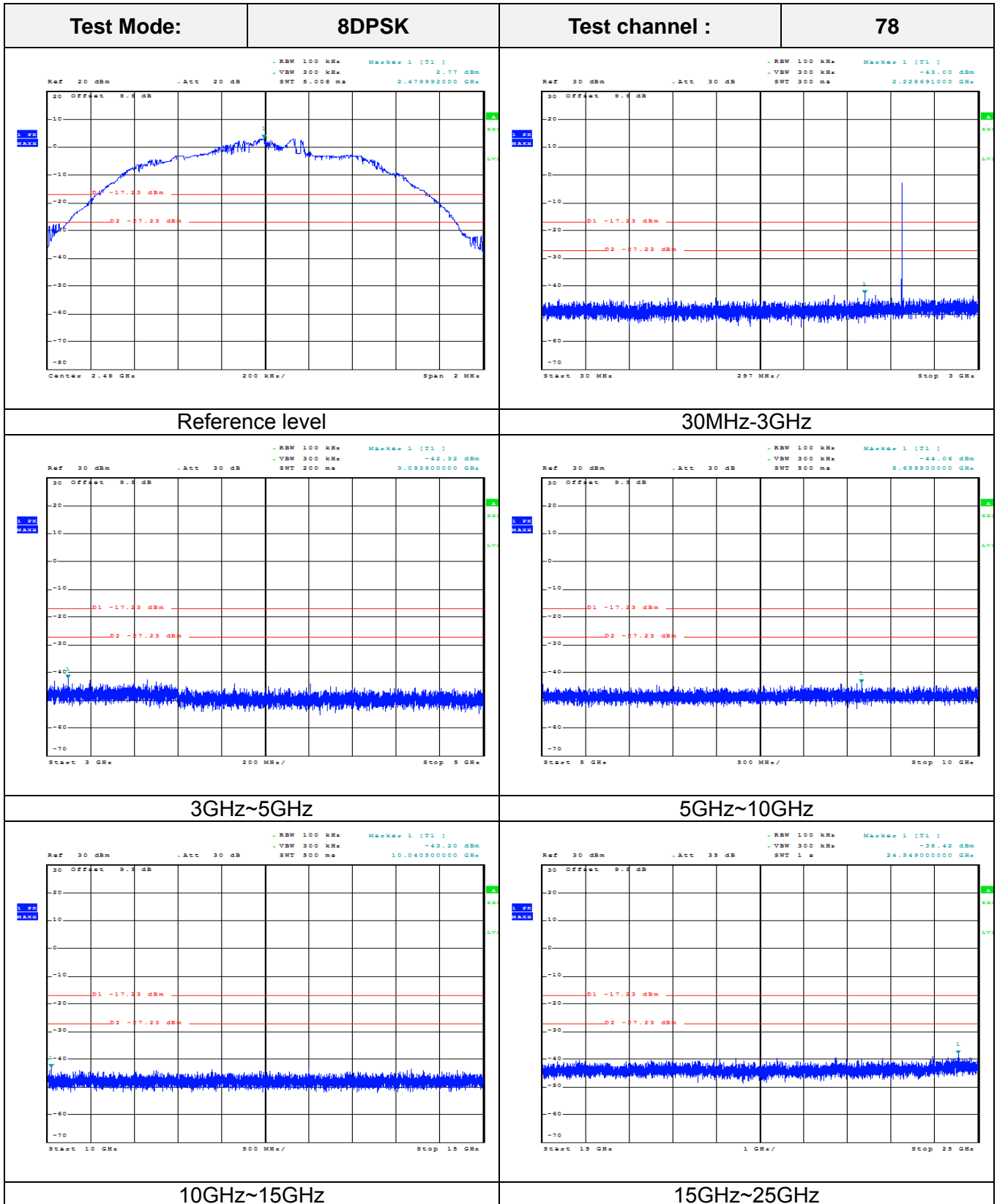

### 3.10. Pseudorandom Frequency Hopping Sequence

#### TEST APPLICABLE

**For 47 CFR Part 15C section 15.247 (a) (1) requirement:**

Frequency hopping systems shall have hopping channel carrier frequencies separated by a minimum of 25 kHz or the 20 dB bandwidth of the hop-ping channel, whichever is greater. Alternatively, frequency hopping systems operating in the 2400–2483.5 MHz band may have hopping channel carrier frequencies that are separated by 25 kHz or two-thirds of the 20 dB bandwidth of the hopping channel, whichever is greater, provided the systems operate with an output power no greater than 125 mW. The system shall hop to channel frequencies that are selected at the system hopping rate from a pseudo randomly ordered list of hopping frequencies. Each frequency must be used equally on the average by each transmitter. The system receivers shall have input bandwidths that match the hop-ping channel bandwidths of their corresponding transmitters and shall shift frequencies in synchronization with the transmitted signals.

#### EUT Pseudorandom Frequency Hopping Sequence Requirement

The pseudorandom frequency hopping sequence may be generated in a nine-stage shift register whose 5<sup>th</sup> and 9<sup>th</sup> stage outputs are added in a modulo-two addition stage. And the result is fed back to the input of the first stage. The sequence begins with the first one of 9 consecutive ones, for example: the shift register is initialized with nine ones.

- Number of shift register stages:9
- Length of pseudo-random sequence:29-1=511 bits
- Longest sequence of zeros:8(non-inverted signal)

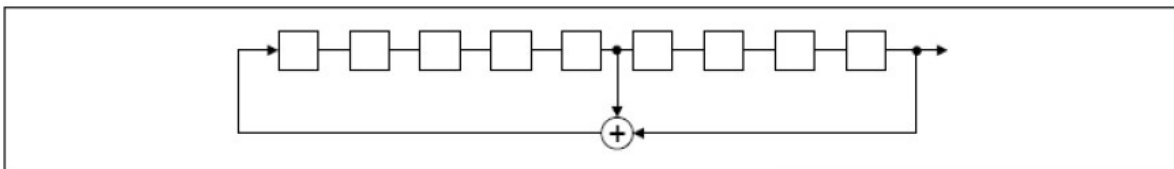

*Linear Feedback Shift Register for Generation of the PRBS sequence*

An example of pseudorandom frequency hopping sequence as follows:

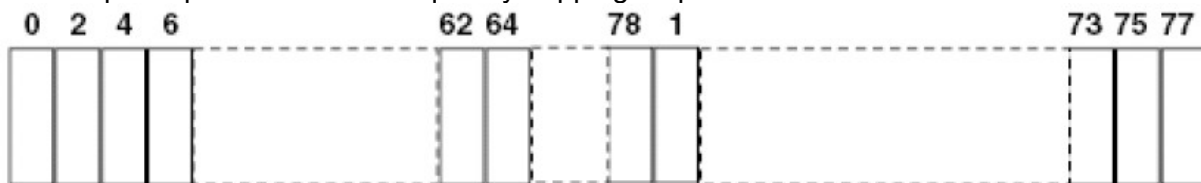

Each frequency used equally one the average by each transmitter.

The system receiver have input bandwidths that match the hopping channel bandwidths of their corresponding transmitter and shift frequencies in synchronization with the transmitted signals.



### 3.11. Antenna Requirement

#### Standard Applicable

For intentional device, according to FCC 47 CFR Section 15.203, an intentional radiator shall be designed to ensure that no antenna other than that furnished by the responsible party shall be used with the device.

And according to FCC 47 CFR Section 15.247 (c), if transmitting antennas of directional gain greater than 6dBi are used, the power shall be reduced by the amount in dB that the directional gain of the antenna exceeds 6dBi.

#### **Refer to statement below for compliance**

The manufacturer may design the unit so that the user can replace a broken antenna, but the use of a standard antenna jack or electrical connector is prohibited. Further, this requirement does not apply to intentional radiators that must be professionally installed.

#### Antenna Connected Construction

The maximum gain of Bluetooth antenna was 1.2 dBi.

Antenna type: FPCB antenna

Antenna connector: pogo pin connector

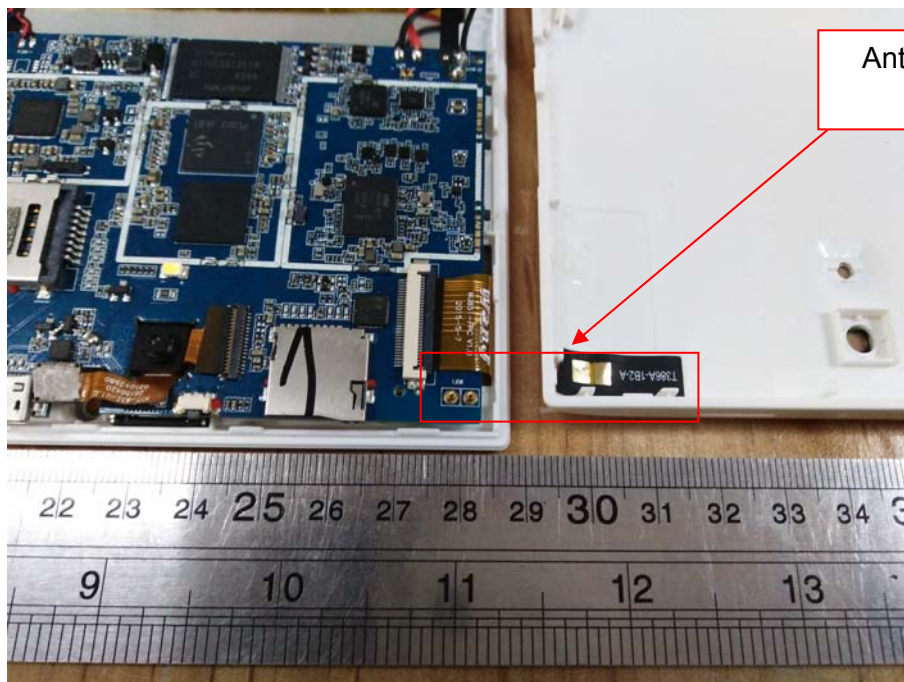

## 4. EUT TEST PHOTO

Radiated Emission (30MHz-1GHz)



Radiated Emission (1GHz-25GHz)



Conducted Emission



## 5. PHOTOGRAPHS OF EUT CONSTRUCTIONAL

### External Photos











### Internal Photos of EUT

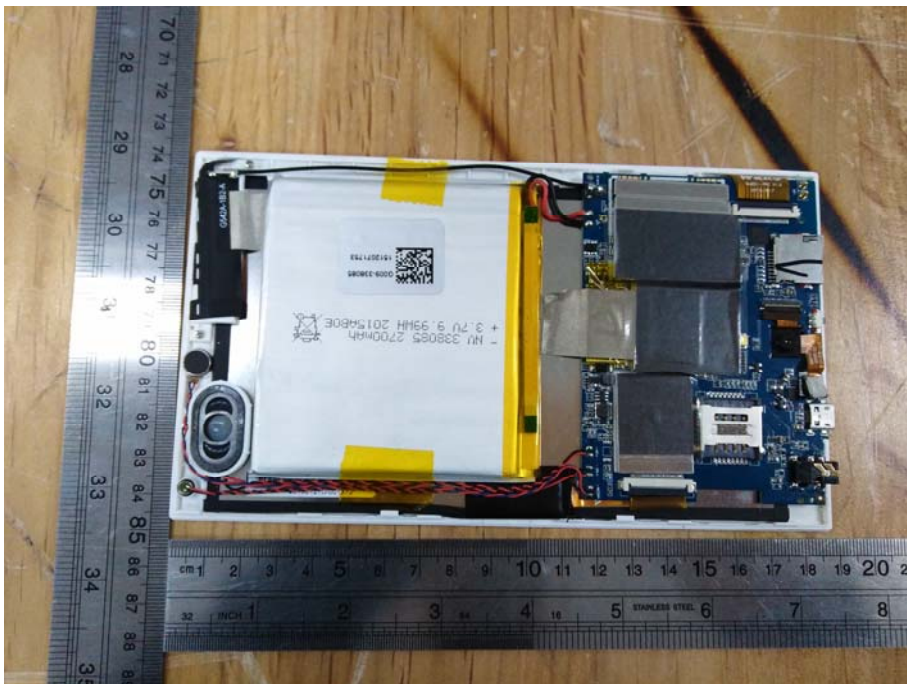



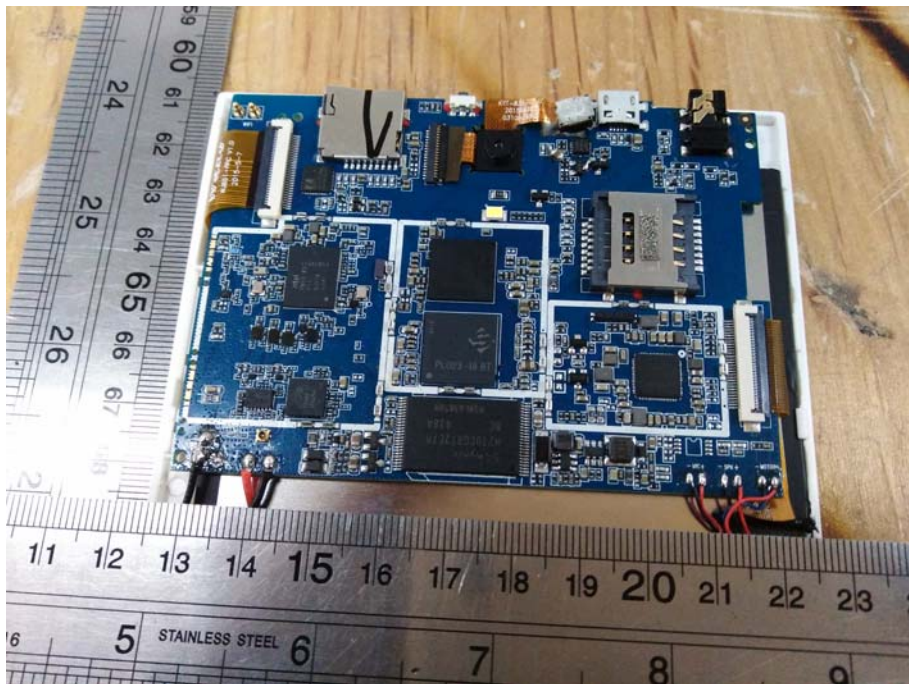
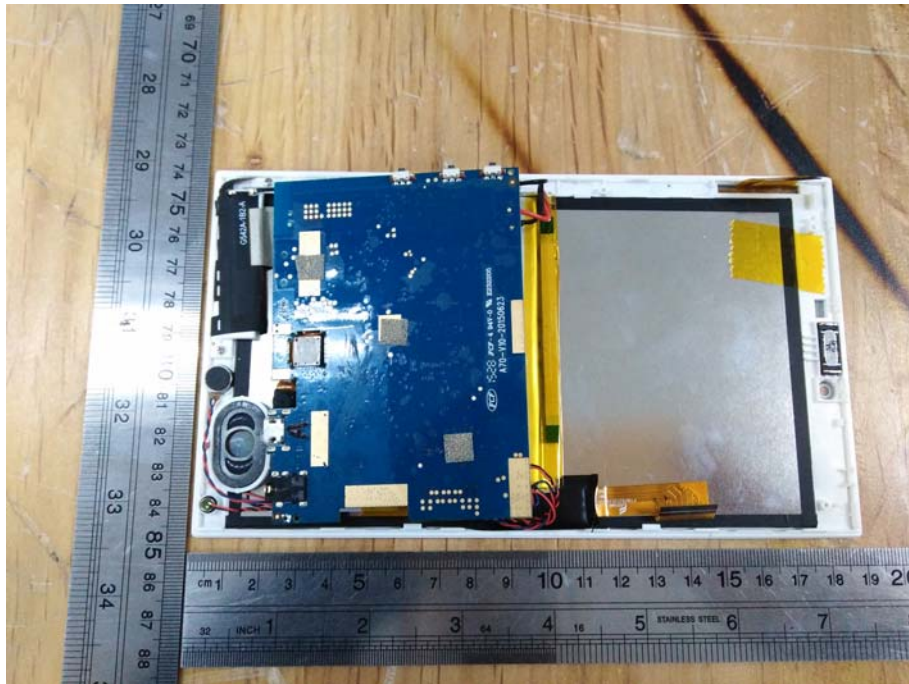

GSM/WCDMA  
Antenna



BT/WIFI  
Antenna

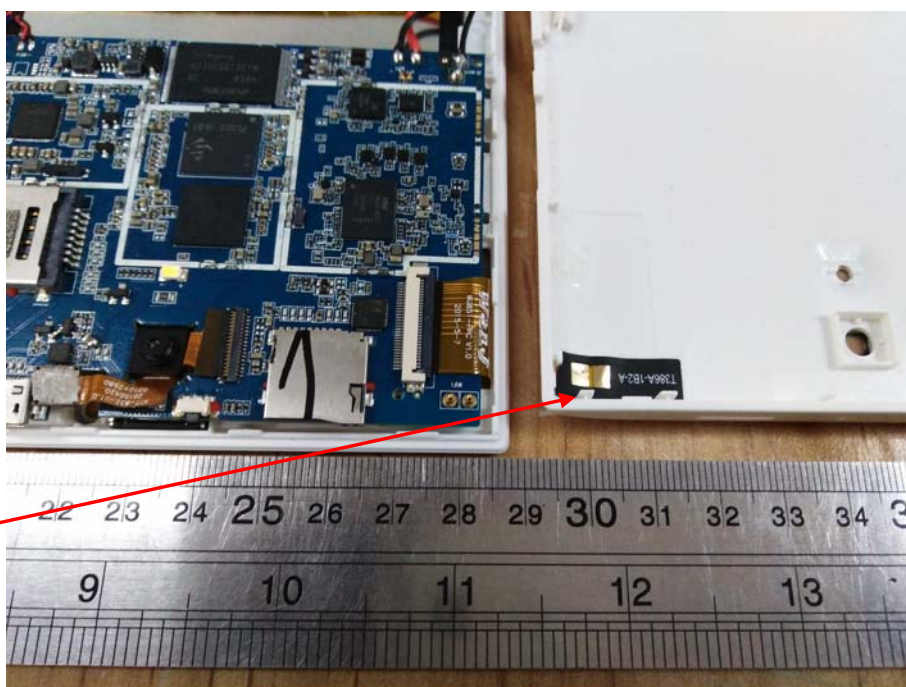

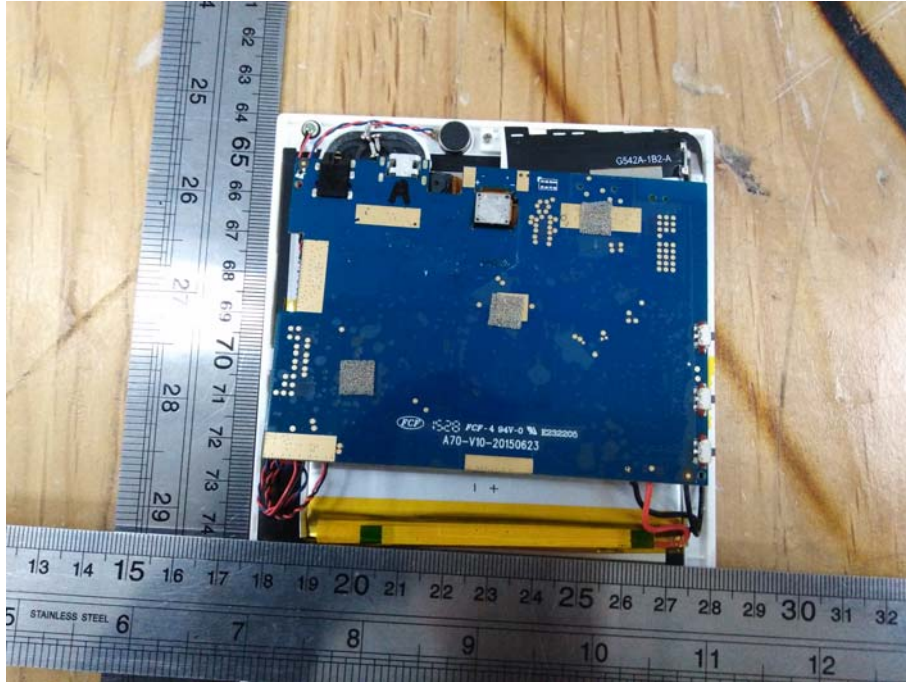

\*\*\*\*\*THE END\*\*\*\*\*